

Development of a System for Producing Stereo Ground Models by Optical Lithography

Yoshinao Aoki* Shin Tanahashi* Osamu Kinoshita* and Hideaki Nakamura**

* Dept. of IE, Faculty of Engineering, Hokkaido University Sapporo,060,Japan
 ** Hokkaido Chizu Co.Ltd. Asahikawa,Japan

1 INTRODUCTION

This paper presents a method of controlling ultraviolet rays by utilizing mask patterns for producing stereo ground models. The LCD display system was developed as a substitute for a mask pattern sheet. Usually an ultraviolet laser and raster scanning are used when producing stereo models by optical lithography. However, this method has some drawbacks such as lengthy procedures when producing large objects and the high cost of optical lithography machinery. We can produce objects more speedily by using a mask pattern sheet and a low cost lamp can be used in the place of a UV laser.

2 EXPERIMENTAL SYSTEM

Fig.1 is an example of stereo ground model produced by optical lithography using ultraviolet laser, where a map of 1:25000 scale was used. (This model was produced by D-MEC Co. Ltd and Hokkaido Chizu Co.Ltd.)

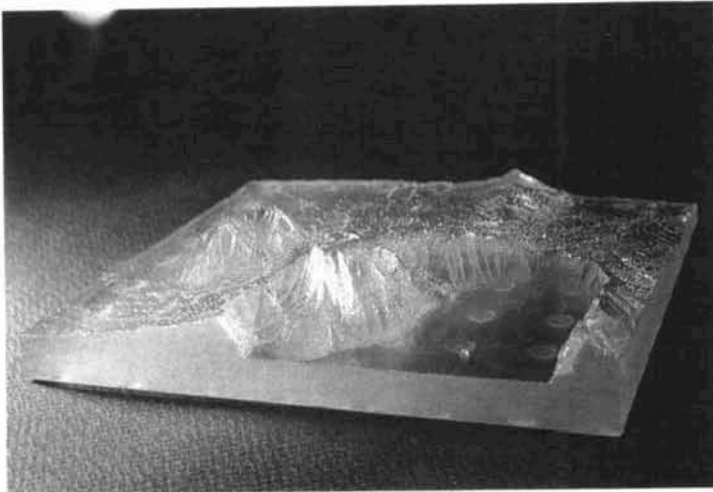

Fig. 1

The model of Fig.1 was produced according to the conventional laser lithography, where a UV laser beam scans the surface of the UV-Ray Hardening resin repeatedly by changing the position of an elevator in a UV-Ray Hardening resin tank(Fig.2), resulting in the final volume model of Fig.1.

In this paper we propose a method to produce stereo ground models like Fig.1 by using mask patterns. Since the raster scanning of a UV laser is not necessary in the mask-pattern method, an optical lithography of high-speed and low cost is expected.

The method which we present is as follows. First, numerous slice pictures are obtained from map. Second, a mask pattern is made from the slice pictures. Third, an UV-Ray Hardening resin is irradiated by ultraviolet lamp through the mask pattern sheet.(Fig.3)

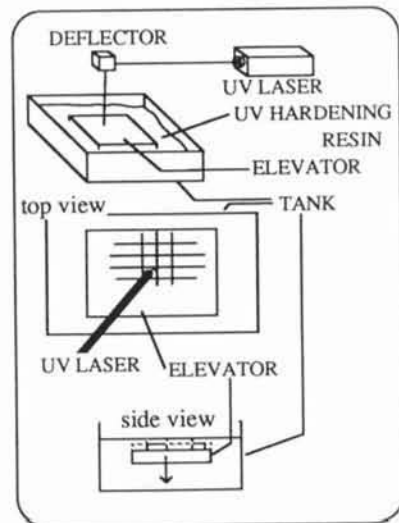

Fig. 2

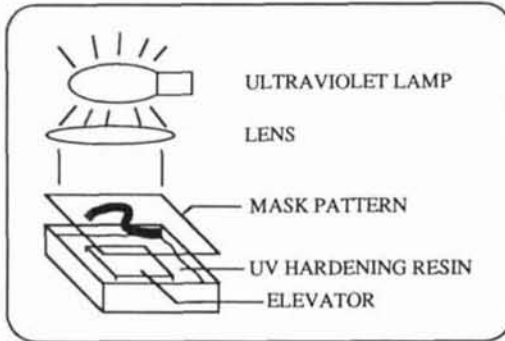

Fig. 3 EXPERIMENTAL SYSTEM

3 EXPERIMENT

We conducted experiments on irradiating the UV-Ray Hardening resin through a mask pattern fixed to a clear sheet. The experimental results are shown in Fig.4. The distance from the ultraviolet lamp(200W) to UV-Ray Hardening resin was 50 cm. The irradiation time was 10 seconds.

4 PRODUCING A MASK PATTERN

Ultraviolet rays were irradiated to one of the contour lines, and were projected on to the UV-Ray Hardening resin. The same procedure was used for every contour line, one by one, starting from the line depicting the lowest altitude. Then, the resin masks are sandwiched together to form a single three-dimensional form. The usable data is then made visible by CRT.



Fig. 4

In fact, it is not critical as to which contour line are used as data. However, to simplify procedures, it is preferable that the data we use at an early stage of the experiment should possess the following characteristics;

1. No excessive complexity
2. Isolated mountain should be delineated by closed contour lines
3. Hollows, such as a caldera, should not be included

It may be, in fact, difficult to distinguish a single mountain from a set of real mountains by the conditions mentioned above, and, moreover, it is not necessary to use the contour lines of a real mountain. Here, instead, at this stage we will create an ideal mountain for use as experimental data, such as in Fig.5.

Following completion of this ideal mountain, we then produce a more complicated one, which is not considered ideal, and finally we apply these procedures with data obtained from a real landform.

At this point, the present data of the real landform are mostly mesh-data. For that reason, we need to transform the mesh-data into data delineated by contour lines. This procedure is rather simple, in that techniques applied to drawing isobars, as used when drawing a weather chart, can be used.

Isobars have similar shape to contour line. (though they are not as complicated as contour lines). The techniques, however, are similar in that a mid-way division between selected air pressure points and mesh-data altitude points (Fig.6) are found (Fig.7) for meteorological data and landform altitude data, respectively. These divisions form the contour lines to be used as masking data (Fig.8).



Fig. 5

A contour line made in this way is, in fact, not entirely smooth, due to that the mesh-data are discrete data. This problem may be dealt with by application of fractal displacement methods for the interpolation of straight lines. With a straight line, such as in Fig.9, this method is applied as follows;

First, point c is moved on this straight line perpendicularly according to the values chosen in the points on the normal distribution curve.(Fig.10) Next, the above same procedures are carried out for lines a-c and c-b.(Fig.11) And, repeat above procedure. However, according to the displacement value, this interpolation technique has the danger of producing a form different from the original landform. It is, therefore, at this stage of development, only useful as a possible method for the expression of complexity of landform.

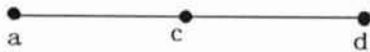

Fig. 9

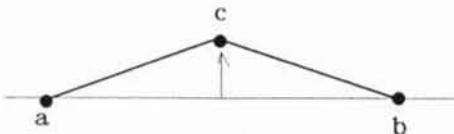

Fig. 10

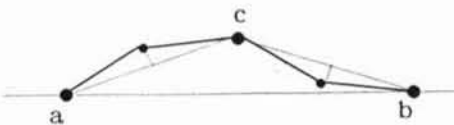

Fig. 11



Fig. 6

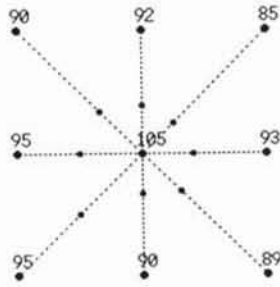

Fig. 7

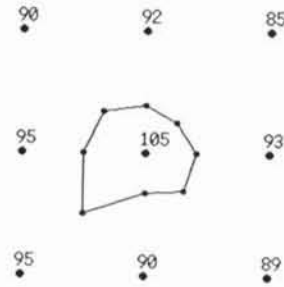

Fig. 8

5 DISPLAY OF MASK PATTERN BY LCD UNIT.

We have produced a mask pattern display system using an LCD unit. Fig.12 illustrates the block diagram of the LCD system.

The mask pattern data produced by personal computer is sent through the interface board to an LCD driver circuit. This data is stored by the RAM in the LCD driver and sent to an LCD display. The structure of LCD driver circuit is shown in Fig.13.

Input data is checked in COMMAND CHECK and the results determine the following commands; exchange memories, set the writing address, or write the data. There are two memories in the LCD DRIVER CIRCUIT. While one memory works for display, we can simultaneously address another memory as well. We can instantly change displays by exchanging two memories. The LCD unit is depicted in Fig.14. It takes approximately 1 second to initiate display by using the LCD unit. When reading the mask pattern data from a floppy disk, however it takes about 10 seconds to initiate display.

6 RESULTS

Although we consider the use of an LCD unit viable as a mask pattern producing method, two problems as of yet remain; endurance of the LCD unit against ultraviolet radiation, and contrast control.

Acknowledgment

The authors thank the Sapporo Electronics Foundation for its support in conducting this experiment.

References

1. T.Sato,R.Mitsuhashi,Y.Aoki:"Fabrication of a 3-D Plastic Model from X-RAY CT Images by Solid Creation System",4th Sapporo International Computer Graphics Symposium Nov.27-28,1990
2. M.Kimoto,F.Tanaka,T.Kishinami:"The System for Making Full-Scale Anatomic Model of Living Body",4th Sapporo International Computer Graphics Symposium Nov.27-28,1990
3. B.Guo,et al:"A Method of Fast Creating Hologram Source Pictures from Single View Image Structure",IEICE Trans Vol.E71,No.5,(May.1988)
4. B.Guo,Y.Aoki:"Fractal Generation of Terrain Model and Surface Rendering for CG Hologram Source Pictures",2nd Sapporo International Computer Graphics Symposium Nov.27-28,1990

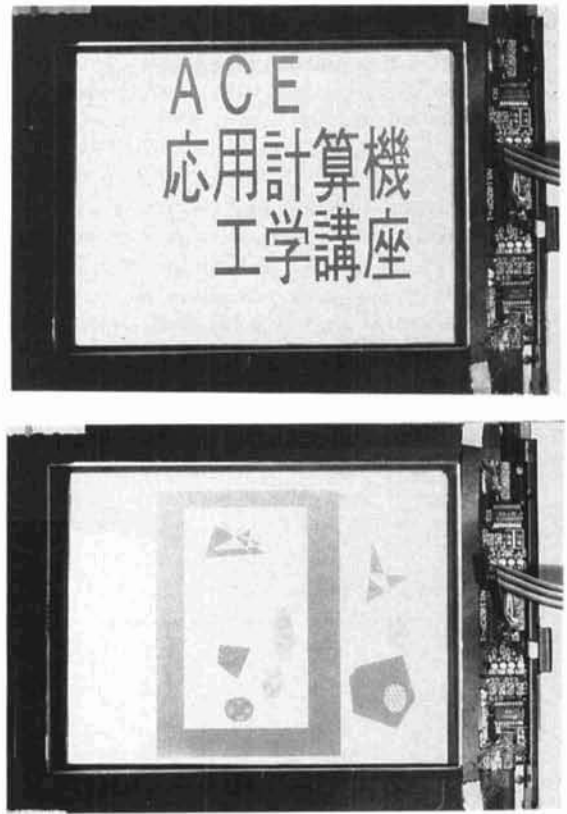

Fig. 14



Fig. 12 BLOCK DIAGRAM

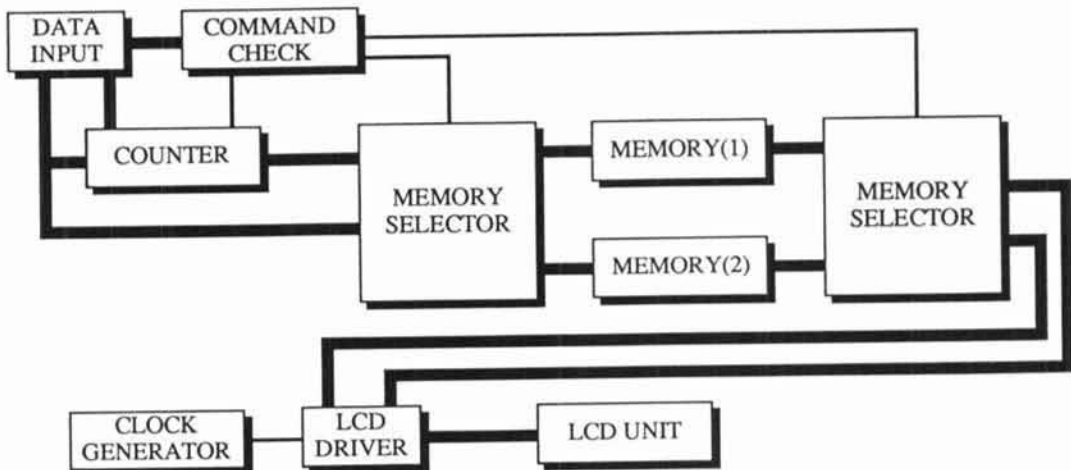

Fig. 13 LCD DRIVER CIRCUIT