

**7700 GALLON
Septic, Pump or Treatment Tank
63" LL 69" Inlet**

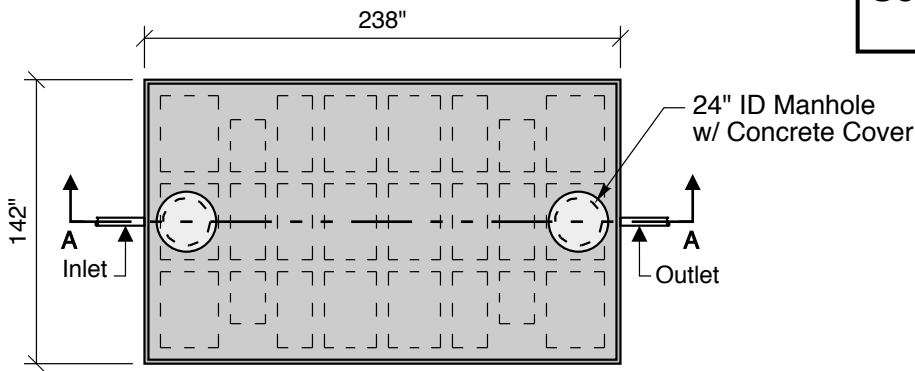

Top View

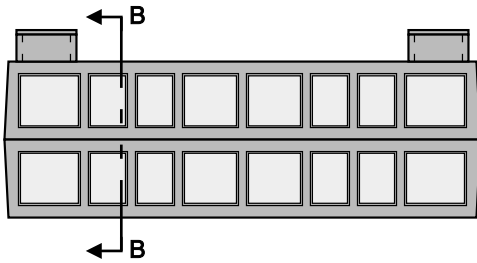

Side View

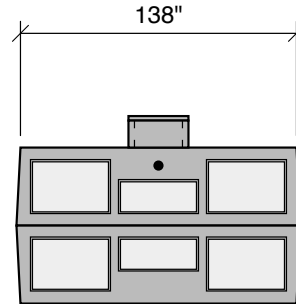

End View

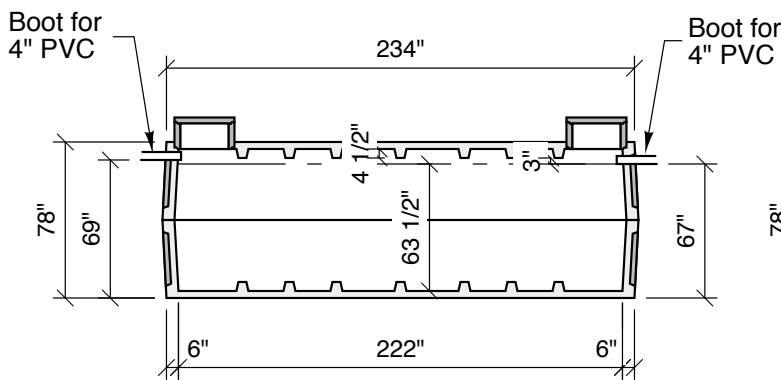

Section A-A

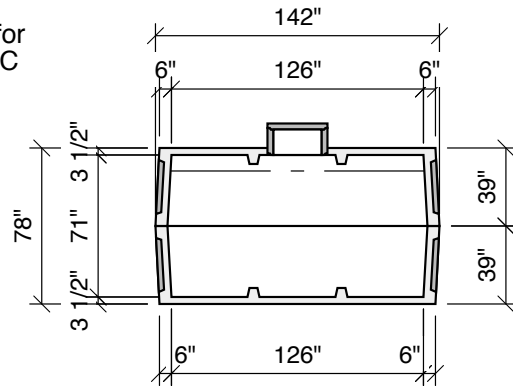

Section B-B

7700 Gallon Septic, Pump or Treatment Tank

Notes:
 Concrete - 6000 PSI w/ Crystalline Water Proofing Admixture
 Joint Sealant - High Grade EZ-Stick
 Labels - Warning signs located on all manholes
 Installation - See separate installation guide
 Rubber Gaskets - Press Seal
 Tank Designed To ASTM C-1227-10 and ASTM 1613-10
 Weight - 23,100 Each Half - 46,200 Lbs Total

Crest Precast, Inc.
 La Crescent, MN & Barneveld, WI
 800-658-9045

Scale		Drawn By:	KGT
Date	1-12-24	Revision	
Project: 7700 Septic, Pump or Treatment Tank			
Contractor:		Drawing Number	MODEL 7700