

**9100 GALLON
2 Compartment Tank
76 1/2" LL 82" Inlet**

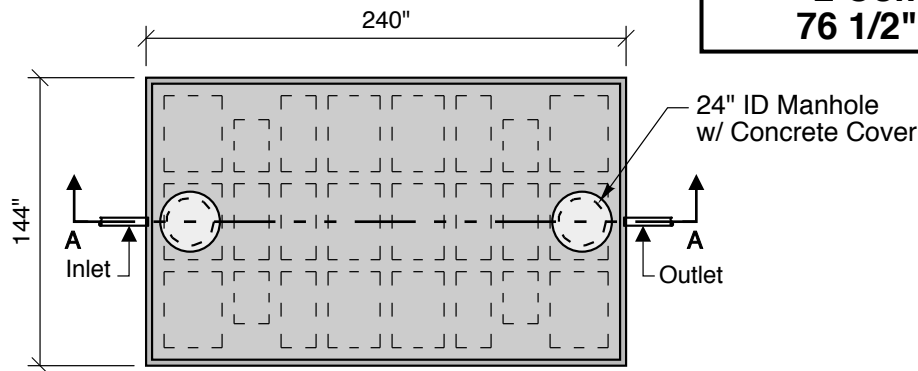

Top View

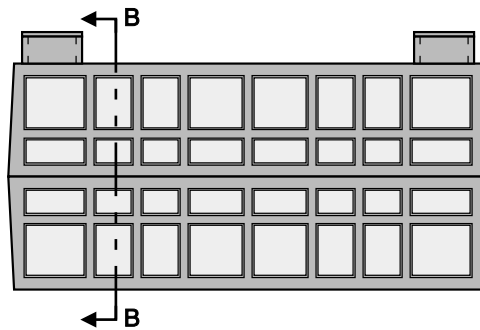

Side View

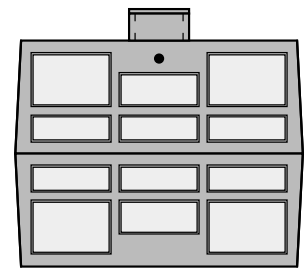

End View

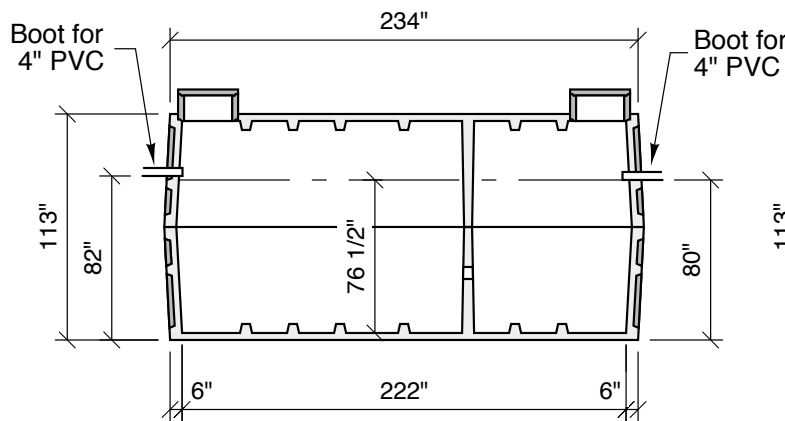

Section A-A

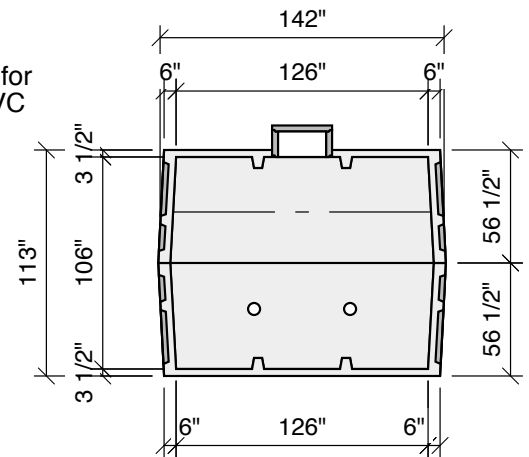

Section B-B

9100 Gallon Septic, Pump or Treatment Tank

Notes:
 Concrete - 6000 PSI w/ Crystalline Water Proofing Admixture
 Joint Sealant - High Grade EZ-Stick
 Labels - Warning signs located on all manholes
 Installation - See separate installation guide
 Rubber Gaskets - Press Seal
 Tank Designed To ASTM C-1227-10 and ASTM 1613-10
 Weight - 33,000 Lbs Each Half - 66,000 Lbs Total

Crest Precast, Inc.		Drawn By:	KGT
La Crescent, MN & Barneveld, WI		Revision	
800-658-9045			
Scale		Date	1-12-24
Project:		9100 Septic, Pump or Treatment Tank	
Contractor:		Drawing Number	MODEL 9100