

# SOUND ON SOUND™

MUSIC PRODUCTION TECHNIQUES / INDEPENDENT IN-DEPTH PRODUCT TESTS / ENGINEER & PRODUCER INTERVIEWS / LIVE SOUND

# Multi-miking

WHEN ONE MIC ISN'T ENOUGH - AND WHEN TWO IS TOO MANY!

## Andrew Wyatt on Barbie

Making the music that made the movie

## Ableton Live 12

Exclusive in-depth review



## EastWest Fantasy Orchestra

Genre-defining scoring collection

**WIN**  
**ANTELOPE AUDIO**  
**ATLAS i8**  
**ACTIVE MONITORS**  
**WORTH £4290**

ON TEST: FENDER / GC / CLOUD / AUDEZE / UA / ADAM / LINE 6 / HUM / ARTURIA / INTECH / GIK / UJAM

TECHNIQUE: MUSIC PRODUCTION ON LINUX / DAW WORKSHOPS

[www.soundonsound.com](http://www.soundonsound.com)

9 770951 681115 02

February 2024 £6.99



Good things come to those who...*Don't have to wait.*

# WA-1B

THE TRACK WHISPERER

Get off the waitlist and finally experience this elite style of compression. Smooth tube-optical tone meets modern dynamic control. A combination that is used by the most discerning professionals to get the best out of their tracks. Custom-core large transformers from Lundahl Sweden plus premium tubes paired with precision controls deliver the ideal compression for the modern project that requires vintage warmth.



ACCURATELY RECREATING WORLD-CLASS SCANDINAVIAN COMPRESSION COMBINING  
SMOOTH TUBE-OPTICAL WARMTH WITH PRECISION CONTROLS

**WARM**  
AUDIO

[warmaudio.com/wa-1b](http://warmaudio.com/wa-1b)



# See us at NAMM

January 25–28, 2024

#17511 North ACC, Level 2



Meet the teams behind the industry's most revered and longstanding brands who, between them, cover the entire spectrum of Tour Sound and Installation applications. See and hear how a host of ground-breaking new product releases are setting new benchmarks in professional audio.

 **Turbosound**

**MIDAS**



ASTON MICROPHONES®

**TANNOY**

**LAB.GRUPPEN**

**lake**

 **tc electronic**

Powered by

**musictribe**



# TRACK STARS

Starting with Bob Clearmountain in the '70s, the specialist mix engineer has become a familiar figure in music production. By the mid-2000s, their role often overshadowed that of the tracking engineer and even the producer. The celebrity mixer was a larger-than-life figure who was often expected not merely to balance the recordings that someone else had made, but to add their own special brand of fairy dust.

Our Inside Track series was created in response to this trend, and across 17 years, has featured almost all of the big names in mixing. Clearmountain is there; so too are Chris and Tom Lord-Alge, Manny Marroquin, Mark 'Spike' Stent, Tom Elmhirst, Tony Maserati, Dave Pensado, Al Schmitt, Jacquire King, Humberto Gatica, Manon Grandjean and (a personal favourite) Andy Wallace. Inside Track has also highlighted numerous stars on the way up.

Mixing is still a vital part of record-making in 2024, but there are signs that its role may be shifting again. It may even be reverting to something more like its pre-celebrity status. Quite a few of the producers and songwriters we talk to are now mixing their own material; others still like to farm mixing out to a specialist, but see this more as a final polishing stage than as a fundamental part of the creative process. Mixers are no longer expected to have a signature

sound, or a secret recipe guaranteeing the label that hires them a hit.

In many ways, this reflects the current state of pop music. There's no one sound that's in fashion, gatekept by experts who can generate it on demand. Almost any style of production can break through as long as it's striking enough to attract attention on streaming services and social media. Authenticity and novelty have become more important than slickness. Production and writing teams are able to produce release-quality material without help. It'll never not be interesting to talk to mixers, but increasingly, it feels as though you're getting one chapter from a novel.

From this month, therefore, we've decided to widen the scope of Inside Track. There will still be room for deep dives into mixing, but we want to be able to give the bigger picture too. We'll be talking not only to mix engineers but also to the songwriters and producers behind today's biggest hits — and where better to start than with perhaps the hottest producer of the moment. Andrew Wyatt has worked with everyone from Lady Gaga to the Rolling Stones, and his collaboration with Mark Ronson has helped the *Barbie* movie become a cultural phenomenon. Pop music has arguably never been more diverse or more interesting than it is right now, and it's people like Andrew who are leading the charge. ■■■

**Sam Inglis**  
Editor In Chief

**“Pop music has arguably never been more diverse or more interesting than it is right now”**



## SOUND ON SOUND

ALLIA BUSINESS CENTRE  
KING'S HEDGES ROAD  
CAMBRIDGE  
CB4 2HY

T +44 (0)1223 851658  
sos@soundonsound.com  
www.soundonsound.com



[WWW.SOUNDONSOUND.COM/SUBSCRIBE](http://WWW.SOUNDONSOUND.COM/SUBSCRIBE)

### WORLDWIDE EDITIONS



UK/WORLD



NORTH AMERICA

### ADMINISTRATION

admin@soundonsound.com

Managing Director/Chairman Ian Gilby

Editorial Director Dave Lockwood

Sales Director Robert Cottee

Marketing Director Paul Gilby

Finance Manager Keith Werthmann

### PRODUCTION

graphics@soundonsound.com

Production Manager Michael Groves

Designer Alan Edwards

Designer Andy Baldwin

Designer Mick Reilly

### SUBSCRIPTIONS

subscribe@soundonsound.com

www.soundonsound.com/subscribe

Circulation Manager Luci Harper

Administrator Nathalie Balzano

### EDITORIAL

sos.feedback@soundonsound.com

Editorial Director Dave Lockwood

Executive Editor Paul White

Editor In Chief Sam Inglis

Technical Editor Hugh Robjohns

Reviews Editor David Gasper

Reviews Editor Matt Houghton

Reviews Editor Chris Korff

Production Editor Chris Korff

News Editor Luke Wood

### ONLINE

support@soundonsound.com

Digital Media Director Paul Gilby

Design Andy Baldwin

Web Content Editor Callum Hall

Web Editor Adam Bull

Podcast Production Manager Atheen Spencer

www.soundonsound.com

twitter.com/soundonsoundmag

facebook.com/soundonsoundmag

instagram.com/soundonsoundmag

### ADVERTISING

adsales@soundonsound.com

Sales Director Robert Cottee

### MARKETING

marketing@soundonsound.com

Business Development Manager

Nick Humbert

Printing Warners Midlands plc

Newstrade Distribution Warners Group  
Distribution Ltd, The Maltings, Manor  
Lane, Bourne, Lincolnshire  
PE10 9PH, UK.

SOS SOS ISSN 0951-6816

A Member of the  
SOS Publications Group

The contents of this publication are subject to worldwide copyright protection and reproduction in whole or part, whether mechanical or electronic, is expressly forbidden without the prior written consent of the Publisher. Great care is taken to ensure accuracy in the preparation of this publication but neither Sound On Sound Limited nor the Editor can be held responsible for its contents. The views expressed are those of the contributors and not necessarily those of the Publisher or Editor. The Publisher accepts no responsibility for the return of unsolicited manuscripts, photographs, or artwork.

© Copyright 2024 Sound On Sound Limited. Incorporating Music-Software magazine, Recording Musician magazine, Sound On Stage magazine, SPL magazine, Sound Pro magazine and Performing Musician magazine. All rights reserved.

All prices include VAT unless otherwise stated. SOS recognises all trademarks.





Most likely to perform in the West-End  
**VTX: A-SERIES**



Most likely to be a high achiever  
**PRX ONE**

Going places  
**EON ONE COMPACT** **EON ONE MK2**



Most likely to fill the dancefloor  
**PRX 900**



Life and soul of the party  
**EON 700**



Outstanding team performer  
**SRX 900**



Easy-going team player  
**IRX SERIES**

CLASS OF 2023



Max power



Pro Connect app control



7 year warranty



Intuitive LCD display





# IN THIS ISSUE

www.soundonsound.com

February 2024 / issue 4 / volume 39

## FEATURES

### 32 How I Got That Sound

Producer Colin Elliot tells us how he brought some drama to Izo FitzRoy's 'When The Wires Are Down'.

### 42 Why Specifications Matter: Part 2

Noise performance is important, but to compare different products fairly, you need to understand how noise specs are calculated.

### 52 Norwegian Black Metal, Part 1: Eirik 'Pytten' Hundvin & Mayhem

Mayhem's *De Mysteriis Dom. Sathanas* is the cornerstone of Norwegian black metal. We talk to producer Eirik 'Pytten' Hundvin about his unique philosophy and the making of this genre-defining album.

### 60 How & When To Multi-mic

Using more than one mic on a source can expand your sonic horizons — but it can also lead to problems. We explain when multi-miking is and isn't a good idea.

### 77 Modular Mixers

We round up some of the best Eurorack mixer modules.

### 80 Inside Track: Andrew Wyatt

The amazing success of the *Barbie* movie was powered by its music. Mark Ronson and Andrew Wyatt were the producers, songwriters and composers who helped to turn the world pink.

### 98 Talkback

Composer, producer and instrumentalist Galya Bisengalieva tells us why the most important things in the studio are focus and a Persian rug.



— WIN —

**ANTELOPE  
AUDIO  
ATLAS i8**

**WORTH  
£4290**

**PAGE 50**

### 104 Is Linux A Real Option For Music?

On paper, Linux has many advantages over macOS and Windows. How easy is it to get started, and how far will it take you?

### 120 Sound On Sound Awards

The results are in! Find out who won in this year's SOS Awards, chosen by you, the readers.

### 134 Q&A

Your studio and recording questions answered.

### 146 Why I Love... Old Keyboard Mixers

Alex Ball on why unloved keyboard mixers have so much to offer.



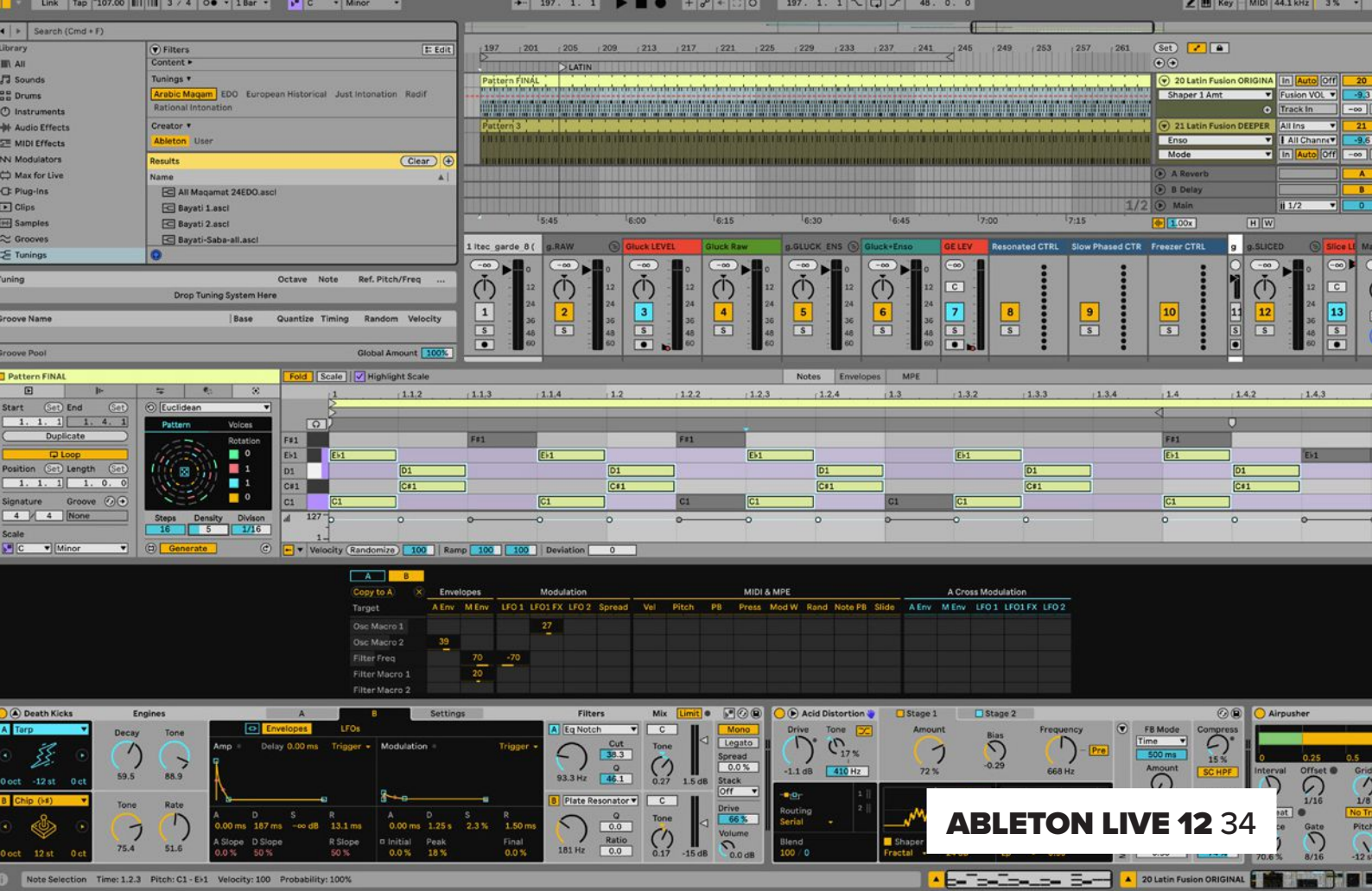

8 **Cloud 44 Midnight**  
Ribbon Microphone

12 **Zynaptiq PitchMap Colors**  
Polyphonic Pitch Processor Plug-in

14 **UJAM Virtual Pianist SCORE**  
Sample Library

16 **Enjoy Electronics The Godfather**  
Mixer & Multi-channel Effects Processor

20 **Audeze MM-100**  
Planar Magnetic Headphones

22 **IK Multimedia Pianoverse**  
Sample Library

26 **GIK SlatFusors**  
Acoustic Panels

28 **Line 6 HX One**  
Effects Pedal

34 **Ableton Live 12**  
DAW Software

46 **Best Service The Score**  
**By Sonuscore**  
Sample Library

56 **Kombo Audio Kombo**  
Portable PA System

## ON TEST

66 **ADAM A8H**  
Active Three-way Monitors

70 **Fender Tone Master Pro**  
Amplifier, Cabinet & Effects Modeller

76 **Befaco FX Boy**  
Eurorack Module

77 **Noise Engineering**  
**Basimilus Iteritas Alia**  
Eurorack Module

88 **HUM Audio LAAL**  
Analogue Mastering Limiter

92 **EastWest Fantasy Orchestra**  
Sample Library

100 **Lumen Handpan**  
Percussion Instrument

108 **Universal Audio OX Stomp**  
Dynamic Guitar Speaker Modeller

112 **Arturia Efx Motions**  
Multi-effects Plug-in

116 **GC Audio Inherit Series**  
Modular Microphone Preamp System

126 **Intech Studio Grid**  
MIDI Controllers

130 **Blackstar St James Plugin**  
**EL34 & 6L6 Editions**  
Amp-modelling Plug-ins

130 **Inorganic Audio Liquid**  
Granular Effect Plug-in

131 **Old Blood Noise Endeavours**  
**Beam Splitter**  
Multi-stage Distortion Pedal

132 **Sample Libraries**  
**VSL Synchron Smart Orchestra**

**Sample Factory**  
Saturn Hybrid Piano

**RT Sonics** Signature Strings

**FrozenPlain** Deep Conjuring

## WORKSHOPS

136 **Studio One**

138 **Pro Tools**

140 **Cubase**

142 **Logic**

# Cloud Ribbon Microphone 44 Midnight



Cloud's stylish RCA-inspired ribbon microphone has enjoyed a dark reboot.

SAM INGLIS

Designers of ribbon microphones today stand on the shoulders of giants. Two such Titans are Harry Olson and Jon R Sank, both of whom will be forever associated with classic RCA ribbon designs. Olson was the genius behind the original 44 and 77, whilst Sank took up the baton after joining RCA's acoustical laboratory in 1957. His crowning achievement was the BK11, a mic that managed to improve on the performance of the 44 in several ways, whilst also being smaller and more lightweight.

The legacy of Olson and Sank lives on in practically every modern ribbon mic, and especially at two American manufacturers.

When RCA abandoned mic production in the '70s, Wes Dooley took on responsibility for servicing and re-ribboning RCA microphones, with the blessing and training of Jon R Sank. Wes founded AEA, who now produce painstaking recreations of the 44 and other timeless RCA designs alongside their original models.

Sank also passed his skills and knowledge to his own son, Stephen Sank; and back in 2009, Stephen teamed up with Rodger Cloud to develop a new line of mics that would build on this RCA design heritage. The first of these was named the JRS-34 in honour of Jon R Sank, who was born in 1934, and it employs many of the innovations that he built into the BK11, notably the use of rounded edges within

the ribbon motor. Cloud subsequently released the 44-A, which is more of an homage to the RCA 44, albeit one that's much smaller and lighter than its inspiration.

Both have proved enduringly popular microphones, but their success has arguably been eclipsed by that of another Cloud product. The ubiquitous Cloudlifter was designed as a simple in-line, fixed-gain preamp, intended to amplify the output of passive ribbon and moving-coil mics to a level that's comfortable for the mic preamps on audio interfaces and small mixers. It has sold by the bucketload, especially to content creators using mics like the Shure SM7B and Electro-Voice RE20 for speech, and there are now no fewer than six Cloudlifter variants in the

»





## PROFESSIONAL MONITOR | TRIO6 ST6

MADE IN  
FRANCE

The new flagship Trio6 ST6 loudspeaker draws on Focal's latest design and engineering innovations to deliver even greater detail, precision and transparency. Fully redesigned speaker drivers and Dual Focus Mode provide even more insight, allowing producers and audio engineers to achieve stunningly dynamic mixes that translate on any listening system. Demand the best. Choose Trio6 ST6.

Only sound, nothing else



» range. The same technology is also built into the Cloud 44-A, the letter 'A' signifying that it's an active, phantom-powered mic.

### After Midnight

The latest mic to enter the Cloud range, and the subject of this review, is the 44 Midnight: a passive version of the 44-A design, without that mic's Voice/Music filter switch, but supplied with a Cloudlifter CL-1 in-line preamp in place of the 44-A's active electronics.

Depending on the design, passive and active versions of the same mic can be more different than you'd expect. Some manufacturers use a different transformer in the active version to derive extra voltage gain, then add active electronics to stabilise and buffer the output. Others retain the same transformer as in the passive version, and use an active gain stage to increase sensitivity. Cloud's 44-A belongs in the latter category, so the Midnight version with the supplied CL-1 should perform exactly like the 44-A in Music mode.

In effect, then, the Midnight trades the convenience of an all-in-one active design for the flexibility that comes with making the active stages optional. To my mind, more is gained than lost by doing this. Most people who are serious about music recording will have good-quality, high-gain preamps, and won't need the Cloudlifter for all applications. The ability to use one gain stage instead of two is theoretically preferable in terms of noise, and having the CL-1 available as a separate device means you can put it to use with other mics, too. The 44's maximum SPL is quoted as 138dB, with or without the Cloudlifter — beyond this point the ribbon motor itself begins to distort, not that it's likely to encounter such levels in real-world use.

### 44 Special

The visual similarities between the Cloud 44 and the RCA mics are obvious from photos, but when you see them side by side, it's the differences that are more striking. The RCA 44 is an absolute beast of a mic, standing over a foot tall with its yoke and placing a serious burden on any mic stand unfortunate enough to have to bear it. The BK11 is somewhat smaller, but still very large and heavy by modern standards. The 44 Midnight, by contrast, tips the scales at fractionally over a pound, and is barely half the height or depth of the 44. Some of that space and weight saving is achieved by not using a yoke-style mount; instead, there's a simple but effective pivoting



■ The 44 Midnight ships with an equally dark-hued version of Cloud's CL-1 in-line preamp.

standmount fixed to the base of the mic, alongside an integrated XLR connector.

The 44 Midnight is supplied with a smart cloth bag, but there's no wooden box or other more robust storage option provided. Build quality is excellent, and the none-more-black 'midnight' finish gives the whole thing a classy yet understated feel. Even though it takes many design cues from the RCA models, it's a surprisingly distinctive-looking mic.

None of the Cloud mics is intended as a slavish recreation of an RCA model. As Rodger Cloud himself says, "The approach that we took while developing the Cloud ribbons was to continually ask ourselves, 'What would Harry Olson and Jon Sank design if they were able to utilise today's innovations, resources and materials?' The goal was always to update these classic designs, rather than clone them, thus bringing them into the modern era for today's demanding applications." So, what you'd expect to get sonically from the 44 Midnight is something that has the same general character as the RCA 44 and BK11, without necessarily measuring the same in every detail — and that's exactly what you do get.

Like most ribbon mics, the 44 Midnight is a true figure-8 design, and it has what seems to be a very well-behaved polar pattern. In terms of frequency response, it follows the RCA 44 pretty closely through the midrange, though it's hardly unique in doing so — as we saw last month, the tiny Extinct Audio BoRbbon also has a very similar character on sources such as vocals. Where it leaves the BoRbbon behind is in its extension at either end of the frequency spectrum. Cloud claim a frequency response of "20Hz to above 20kHz", and although the supplied chart

shows that treble response is attenuated beyond 8kHz, it's clear that the 44 Midnight does capture both deep bass and air frequencies. If the latter aren't prominent enough for your tastes, a particular strength of the 44 Midnight is its malleability through EQ. Ribbons in general are said to "take EQ well", and Cloud's design is an excellent showcase of this property.

In practice, I found I rarely needed to use the 44 Midnight with the Cloudlifter. Its sensitivity of 3.5mV/Pa as a passive mic is perfectly respectable, and within a couple of dB of most modern ribbon mics. With care I was able to use it as a close vocal mic, and although the grille gives the impression of being very open, the fine-mesh gauze behind it seems to offer decent protection against pops and other minor wind blasts. The ribbon motor is also internally shockmounted, so even though the mic would usually be mounted directly to the stand, stand-borne vibration isn't a problem. As with all the best microphones, you can freely vary mic placement to shape the sound of what's recorded, without having to worry about off-axis coloration or noise. And like all good ribbons, the 44 Midnight is surprisingly versatile, putting in a good performance on everything from fingerstyle guitar to front-of-kick or overhead duties. This is a very classy mic indeed, and is both more affordable and more practical than an original RCA 44 or BK11. ■■■

### summary

A high-quality passive ribbon mic supplied with a high-quality in-line booster, the 44 Midnight is pure class.

£ £1699 including VAT.

W [www.cloudmicrophones.com](http://www.cloudmicrophones.com)



Visit us at  
**The NAMM Show**  
January 25–28 2024 **Booth 16311**

# NEW RADICAL BUNDLE 4



break your sound free.



Radical® Bundle 4  
Learn more  
[www.soundradix.com](http://www.soundradix.com)

**SoundRadix**  
break free.



# Zynaptiq PitchMap Colors

## Polyphonic Pitch Processor

This clever plug-in could breathe new life into your old loops and projects.

PAUL WHITE

Like Zynaptiq's original PitchMap, PitchMap Colors is essentially a polyphonic pitch-domain tool, but whereas PitchMap was geared towards changing tuning in a fairly natural way, PitchMap Colors is intended to make more obvious transformations to the source material. It works by splitting the incoming audio into chromatic pitches, then shifting them to match notes on the on-screen keyboard, in an existing MIDI track, or in a live MIDI input. The outcome is that any piece of music, in any key, can be conformed to fit the notes or chords that you decide are appropriate — and that makes it a wonderful tool for processing sample loops to make them fit your current project, or potentially for reworking some of your existing material. Interestingly, PitchMap Colors can even apply harmonic characteristics to atonal or noise-like sounds, so even industrial sound recordings can be turned into something melodic.

### Overview

Instructions for how to set up PitchMap Colors in all of the popular DAWs are included in the documentation, revealed via the question mark icon, while the icon to the left activates mouse-over prompts for the various control functions.

The GUI looks fairly straightforward, with three large mode buttons above the virtual keyboard. Below the keyboard are five buttons, four of which (A, B, C and D) can store preset chords. The fifth enables external MIDI control. A further row of parameters is shown along the bottom of the screen. There are three operating modes with different sonic characteristics, specifically Sick, Insane and WTF. Sick is the smoothest and stays the closest to the original input's sound, but it can miss capturing all the harmonics of the input on some types of material, which can lead to a slightly detuned effect. Most of the time, though, it works pretty well. Insane is the most processor-intensive mode but isn't as mad as it sounds — it imparts a resonant, shimmering texture and is better at capturing harmonics, though it can miss capturing transients. WTF is similar to Insane but uses less CPU and this adds a somewhat reedy character to the sound, giving it a slightly robotic quality.

Scale Shift does as it implies, moving the whole pitch up or down, while Pitch Rounding dictates how the incoming pitches are mapped: to the nearest chord note, or the nearest upwards or downwards chord note. The next button can be set to Mute or Bypass and determines how notes outside of the pitch mapping range are treated. Transient Bypass is an important one, as it can restore transient detail to those modes that need it by adding transient information (up to 200 percent) back into the output, though when active this feature increases the CPU overhead.

Formant Shift moves the formants of the mapped audio up or down in semitone increments (or one-percent increments using shift-drag, numerical entry or automation) without changing the pitch, while FMT Gamma sets how strongly formants are exaggerated. When moused over, the curves seen either side of the keyboard reveal the minimum and maximum pitch value settings as well as adjustable high- and low-cut filters. That leaves the arrow keys to either side of the keyboard, which steps the current note or chord up or down in semitone steps.

### Mapped Out

PitchMap Colors works extremely well. Its processing sounds very smooth and it's capable of some extraordinary results, whether adapting a loop,



conforming to a new chord structure or simply creating drones. The four chord memory buttons can be automated, but it's great that you can just work from a MIDI track or live MIDI input. Hearing a familiar piece of music suddenly conform to your own chord sequence is uncanny.

The only downside really is its thirst for computing power. Used with Logic Pro X and a live MIDI input, my i9 MacBook Pro struggled initially to keep up with the most processor-intensive permutations unless the buffer size was set at 1024. My M2 Mac Mini fared somewhat better but still needed a 512 buffer size when using Insane with the Transient Bypass feature turned on. These large buffer sizes are recommended by Zynaptiq because the underlying FFT process is pretty intensive. Note, though, that in Logic Pro X the CPU loads drop to around half if the instrument track isn't set for a live input — if you're using a pre-recorded MIDI track to control the plug-in, ensure the red R on that track is not illuminated. For computers of lesser power, the only option would be to do an offline bounce to capture a clean result, and I suspect that most users would choose to bounce the results anyway before adding other high-CPU plug-ins to their project. Nevertheless, if your machine is up to snuff, there's a lot of creative potential to be explored here and Zynaptiq have to be given their due for daring to go where other developers fear to tread. **///**

### summary

An impressive polyphonic pitch-processing audio plug-in capable of responding to a live MIDI input — assuming your machine is up to the job.

£ €109 including VAT.  
W [www.zynaptiq.com](http://www.zynaptiq.com)



# **KMR | DEMO ROOM**

NO TALKING. JUST AUDIO.



we demo the gear... so you don't have to.

**// [www.kmrdemo.com](http://www.kmrdemo.com) //**

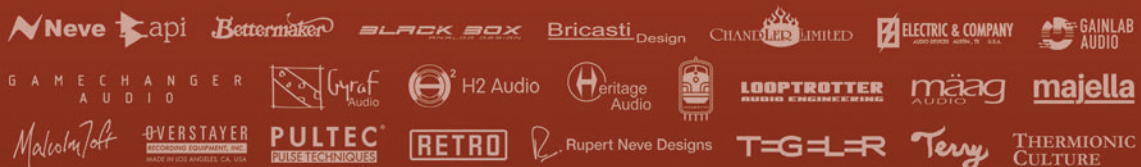

 **KMR**  
we know pro audio

JOHN WALDEN

UJAM have recently expanded their 'virtual musician' instrument range to include both synth and piano-based options. The latest in the Virtual Pianist line is SCORE and, as the title suggests, the performance style under the spotlight is most likely to appeal to media composers. So, if film, TV, video or game soundtrack creation is your thing, could UJAM Virtual Pianist SCORE be a useful software-based session musician to keep in your studio?

### Right On Cue

SCORE follows UJAM's well-established design ethos in that pretty much every control you need to access is contained within a single window. Over the years, this streamlined approach has been very cleverly refined to give the user additional options to 'direct' the various virtual performers. SCORE offers the latest iteration of that and, as such, it includes the ability to switch between two modes; Player (SCORE creates a performance based upon the notes or chords you play) or Instrument (it behaves as a conventional virtual piano instrument), giving you flexibility in how the final performance is created.

The underlying piano sounds are based upon a sampled Steinway D, but you also get multiple ways to adjust the sound via the five 'character' presets, the Dark-Light slider, and via the Finisher and Ambience presets. These last two can introduce additional samples (for example, various string styles) and some impressive creative sound design, letting you go way beyond standard piano sounds when your cue requires it. Sonically, therefore, SCORE is suitably cinematic.

### Star Performer

Embedded within the 175 global presets, SCORE offers some 40 performance preset styles in Player mode. Each of the latter contains six performance 'intensity' options plus additional keys for triggering low/high chords and add-on, style-specific, note fills for an extra flourish, all available via trigger keys. You also get velocity/dynamic control (via the pitch-bend wheel) and 'Busyness' (via the mod wheel), with the latter influencing the number of notes triggered. Finally, the three chord voicing modes — Simple, Universal and Complex — also influence how the virtual pianist performs.

You then simply trigger MIDI notes — either single notes or multiple notes (SCORE's chord recognition converts

# UJAM Virtual Pianist SCORE



## Sample Library

UJAM target media composers with the latest addition to their Virtual Pianist instrument series.

note combinations into chords within your chosen key) and let the performance happen. Essentially, SCORE will adapt its in-built performance styles to suit your chord sequence, and you can adjust the intensity and dynamics via the various trigger switches and mod/pitch wheel options. You can also guide the left-/right-hand note range using sliders on the coloured mini-keyboard display.

Stylistically, SCORE covers quite a lot of ground with performance presets that go from relatively simple to more specialised. However, they all do exactly what most media composers are looking for; they create a musical mood. It is breathtakingly easy to build the core of a cue that targets a specific emotion with just a few notes and/or chord changes.

### Final SCORE?

It's also worth noting that you can drag and drop MIDI from SCORE to your host and build a performance from that if you

prefer. SCORE can then be switched to Instrument mode for playback. And, added in an update that appeared as I was writing this review, you can now also send MIDI out from SCORE to another virtual instrument. This worked perfectly in Cubase Pro 12 on my test system and opens up all sorts of interesting possibilities, although I don't think it is currently supported within Logic.

SCORE is the first of the UJAM Virtual Pianist plug-ins that I've had the chance to fully explore. It's difficult not to be impressed with the workflow, sounds or creative possibilities. I'll be more than happy to keep SCORE within my music-making toolkit and I'll now be keen to try the other two currently available titles; Vogue and Vibe. You can too, because UJAM have free 30-day trials of all three — and a tempting bundle price — available on their website. SCORE scores on all fronts; go check it out. **///**

### summary

SCORE sounds great, is easy to use, and can create some fabulous performances. Aspiring or busy media composers will love the inspiration it can offer.

£ £125 including VAT.

W [www.ujam.com](http://www.ujam.com)





# THE FUTURE OF DAW CONTROLLERS HAS ARRIVED!

## INTRODUCING THE V1-M and V1-X DAW CONTROLLERS

Presenting the new standard in MIDI DAW control surfaces - the flagship V1-M DAW controller, featuring a large 7" 24-panel, programmable digital touch screen, 9 touch-sensitive motorized faders with 12-bit resolution, a big high quality large optical encoder jog wheel, a beautifully designed meter bridge with OLED display, multiple simultaneous DAW control, highly advanced iMAP™ software for completely re-arrange how DAW functions appear (via 'drag and drop'), easy plug-in control and intuitive, intelligent design. The world of MIDI DAW controllers has just changed.

Exclusive distribution:  
sound  service  
MSL DISTRIBUTION LTD

[www.iconproaudio.com](http://www.iconproaudio.com)

**i**CON  
Pro Audio



# Enjoy Electronics The Godfather

## Mixer & Multi-channel Effects Processor

This unique combination of mixer and effects machine can be used standalone or as part of a modular setup.



WILLIAM STOKES

The launch of Italian company Enjoy Electronics' new hardware effects processor The Godfather was teased for months with Mafia-themed videos, but finally, after a very successful crowdfunding campaign (I gather they reached their Indiegogo target in 19 minutes) the wait is over. The Godfather recently found its way into my studio, and this 3U-high, 60HP multi-channel processor is a very pretty piece of semi-modular design, boasting four glorious channels of mixing, dynamics shaping, frequency sculpting and effects processing... and more.

### Overview

Most of the left half of The Godfather's panel space is occupied by the four channel strips, while the right is home to its screen and accompanying menu encoder, an effects section, a modulation matrix, some function keys and a patchbay. Each channel can be routed to one of two sets of stereo outputs, and features a large, LED-ringed, push-turn encoder that Enjoy refer to in the 126-page manual as the Revolver control. Thankfully, that's where the Mafia references end; I'll resist adding my own!

"We don't play with plastic" say Enjoy on their website, and it has to

be said that the build quality of The Godfather is impeccable. Wooden side panels, smooth and firm aluminium knobs, a very smart use of LEDs and a high-resolution OLED display all coalesce to form something that, physically, is a pleasure to operate. The LEDs (154 in total, we're told) immediately impressed me, and most conspicuously form the sleek strips that adorn each channel. I didn't even realise these strips were made of lights until I switched the thing on, but they are and they perform a number of different roles: they can be three-colour VU meters; they can inversely display compression behaviour (The Godfather has brilliantly usable compression on board that also allows channels to be side-chained from others); they can indicate a sound's place in the stereo field; and they can denote values relating to parameter changes. As users become fluent, they might even be able to adjust The Godfather's parameters without so much as a glance at any on-screen values.

Each Revolver encoder adjusts the master level of its channel, just as on a conventional mixer, but it also performs a host of other functions including channel selection. Hold the Off button on the other side of the panel, for instance, and click the encoder to mute that channel. Hit the Compression button

and use it to adjust the different settings of that channel's compression. Control the input gain when used in conjunction with the Gain button. Next door to the Revolver encoder is a dedicated knob for wave-shaping saturation, and while this doesn't impart massively heavy grit, it does pleasingly thicken and warm its channel's sound in just the way I'd hoped. In conjunction with the input gain control, then, there's plenty of scope for gain staging, and there's a generous degree of creative control over the tonal character of a channel. It's all accessible, quick, intuitive — and impressive.

### Effects & Control

Next, as you move along the channel strip to the right, are the controls for delay and reverb. I'd argue that much of The Godfather's character stems from these effects, and it's certainly an area that Enjoy Electronics have sought to use to differentiate The Godfather from its peers. Broadly, it's better to think of these effects as being like 'sends' rather than 'inserts'. While it is possible to tweak parameters for individual channels, the primary controls for both effects are in the global section, and The Godfather's workflow fundamentally encourages you to adjust the reverb and delay as required and then return to the channel strip to adjust how much signal is sent to the aux. >>



# AMPLIFY YOUR CAREER AT LONDON SOUTH BANK UNIVERSITY

## Join an MSc or IoA Diploma programme in acoustics this September

- **Excellent employability prospects:** There is great demand for acoustics graduates (according to the Association of Noise Consultants), and these courses offer a fantastic opportunity to join the industry and advance your knowledge.
- **35-year legacy:** We have a longstanding reputation of delivering acoustics education, with award-winning teaching and amazing facilities including a full-size reverberant and anechoic chamber.
- **Our students win awards:** Including the Newman Student Fund Award and National Apprenticeship Awards (2023).

### But don't just take our word for it – here's what leading employers have to say about our graduates:

"Studying acoustics at London South Bank University (LSBU) will not only equip you with the knowledge and skills you need to succeed in this field, but also open up many opportunities for you to work with some of the best acoustic professionals in the UK. At Apex Acoustics, we have always been impressed by the quality and performance of LSBU graduates."

*Jack-Harvie Clark, Managing Director of Apex Acoustics*

EST 1892  
**LSBU**  
London South  
Bank University

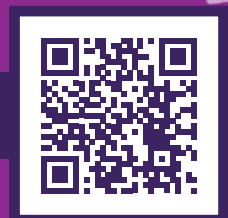

Take the next step in your career journey today

\*Chartered Institution of Building Services Engineers (CIBSE) accreditation only applies to the MSc Environmental and Architectural Acoustics.



» The reverb has user-adjustable parameters for size and amount, and a fixed-resonance high-pass filter. There's no choice of algorithms (eg. hall, plate, spring), but it sounds so good that this doesn't really matter. The reverb is placed right at the end of a channel's signal chain but, interestingly, delay is very close to the beginning, before even the saturation — that's a clear indication that delay lies right at the heart of The Godfather.

By default, delay parameter changes apply globally, but you can limit them to one or more channels by pressing their Revolvers. Time and feedback are joined by a useful Offset knob, which creates a lush stereo separation by introducing another delay between repetitions in the left and right output channels. At maximum settings, the feedback will loop a sound forever, but it never moves into true self-oscillation territory; I think that's the right call for this device.

The Trigger buttons (one for each channel) are not used nearly as frequently as their prime position on the strip might suggest, but their accessible placement makes sense given that they serve The Godfather's more performative aspects. Ostensibly, each button allows for the manual control of input routing to delay lines in accordance with one of three different modes called Normal, Add or Change, and these, respectively, enable the muting, changing or replacing of the signal moving through the delay lines. Responsive and sonically rewarding, these trigger buttons are something of a secret weapon when it comes to dynamic, hands-on performance.

Things get more complex with the introduction of DPD, or 'double

pulse delay', which again has its own dedicated knob on each channel. This introduces two more delay lines into the main delay, for complex rhythms and stuttering, and even unpredictable behaviour. The DPD even has its own dedicated low/high-pass filtering, so it can be tuned to perform nicely alongside the main delay line without muddying things beyond recognition.

Last on the bill of knobs for each channel is a bipolar filter that sounds smooth and clean, and is good for broad-strokes tone control. It makes sense, particularly when modulation is added to the picture. I will say, though, that I was disappointed not to find a more complex EQ accessible via the OLED screen; with its size and resolution the screen manages to display a full compression graph; it could surely handle an encoder-controlled graphic EQ too.

On top of all this, The Godfather offers LFO-based modulation. Two clock-sync'able LFOs can be assigned to modulate a variety of destination parameters, from reverb amount to saturation, and there's a selection of waveforms to choose from. Their outputs can also be sent externally as a control voltage from two nearby jacks. The workflow of these I found a touch convoluted, with a rather complex series of pushing and turning combinations to choose waveforms, destinations and either global or channel-specific functions. But once routed and running it's an excellent feature that really adds value to the whole package.

Now: a powder-coated black aluminium faceplate, wooden side panels and patch points all down the right hand side. Sound familiar? Yes: The Godfather has been designed to nestle snugly in with Moog's 3U semi-modular range. They've even created a 60HP frame (available separately) to house five units in a hybrid semi-modular system. It's not that Enjoy have set out to mimic Moog, though — for example, they've not opted for Moog-style knobs. Custodians of those

■ Stylish wooden endcheeks host a backlit logo, while the top panel sits at an angle to make hands-on desktop control easy.

aforementioned Moog semis should find The Godfather an ideal bedfellow for them, with its patchability and channel count pretty much tailored to suit their workflow.

I am also a big fan of Enjoy's decision to arrange The Godfather's channels laterally, with channel strips running left to right rather than vertically. This makes great use of The Godfather's relatively slim 3U real estate, and Enjoy have succeeded in making it feel as spacious and tactile as anything you're likely to find in this format. In fact, if anything, The Godfather is in danger of making nearby Moog panels appear somewhat cramped by comparison!

## Verdict

Enjoy Electronics are certainly confident in The Godfather, proclaiming that it will "make you definitively abandon conventional mixing concepts and immediately improve your creative skills". It's a bold statement, but one The Godfather does more than a little to justify. Mixing comes last in the signal chain for most electronic music setups, and just as often it's last on the list of priorities. While it might not become the overlord of your entire workflow, The Godfather seeks to change that, combining the functionality of a mixer with the creative fun of a modulation-ready, effects-imparting, sound-sculpting Eurorack module. Also, this thing has its own sound, which can't be said for the vast majority of similar mixers out there. But even if you're not a Eurorack user, it works as a standalone device that will interface very happily with all manner of drum machines, synths and samplers, whether CV patchable or not. I'd imagine some firmware updates are on the way to help smooth out a few idiosyncrasies, but fundamentally The Godfather can already be considered great success. An offer you can't refuse? Argh, sorry. Couldn't resist. ■■■

## summary

This uniquely creative combination of mixer and effects processor is designed with Moog and Eurorack in mind, but has wider applications than that.

£ The Godfather £1,149. 60HP frame £160. Prices include VAT.

T The Groovebox +44 (0)20 30044716

E info@thegroovebox.co.uk

W www.thegroovebox.co.uk

W www.enjoy-lab.com



# iD24

Your recordings  
made better



## 10in | 14out Audio Interface

2 x Audient Console Mic Preamps | Class Leading AD/DA Converters  
1 x JFET Instrument Input | 2 x Fully Balanced Inserts | 1 x ADAT Input & Output  
Ultra-Low Latency | Audio Loop-back | Dual Headphone Outputs | USB 3.0

# AUDIANT



# Audeze MM-100

## Planar Magnetic Headphones

Audeze's latest headphones make Manny Marroquin's signature sound more affordable than ever.

SAM INGLIS

As Head of Professional Products at Audeze, Manny Marroquin's role has extended well beyond simply lending his name. His signature MM-500 open-backed headphones built on the strengths of existing Audeze models — superb dynamics, endless bass response, low distortion — whilst trimming the size and weight that their planar magnetic design would usually entail. They are also voiced differently from Audeze's LCD models, with a more prominent upper midrange.

Another of the celebrated mix engineer's goals was to bring Audeze's technology to a wider audience, but, at not far short of £2000, the MM-500 isn't exactly a budget model. It turns out, though, that it was only the first step along this particular road. The second Manny Marroquin model retails at less than one quarter of that price.

### The 100 Club

A sticker proudly advertises that the MM-100 is manufactured in the USA, and there are no obvious corners cut in build quality. Whereas the MM-500 comes with a hardcase, the MM-100 includes only a soft bag, and in place of the MM-500's Y-shaped cable, the MM-100 has a more conventional cord that connects to the phones using a mini-jack. Both earcups have jack sockets, so this can be plugged into either side at your convenience. The other end of the cable terminates in a fixed quarter-inch jack, with no mini-jack adaptor supplied.

Colour and connectors aside, the earcups seem identical with those in the MM-500, and they are mounted on similar Y-shaped metal yokes, permitting both up/down and forward/aft rotation. However, the system for adjusting their height has been simplified. The effective length of the inner part of the headband can be varied by selecting which of the three pairs of holes at either end should mate with the pegs on the outer part. It's a more basic version of the arrangement used in HEDD Audio's HEDDphone TWO, and in both cases, what looks on paper like a rather limited set of

stepped positions offers plenty of adjustment in practice. All of these changes shave off another 20 grams compared with the MM-500, bringing the weight down to a very comfortable 475g.

Many of the MM-100's specs are identical to those of the MM-500, thanks to the use of a very similar 90mm planar magnetic driver. Frequency response is quoted as 20Hz to 25kHz, as against the MM-500's 5Hz to 45kHz, but since no tolerances are quoted, there's not much that can be inferred about how they sound. Both models present an 18Ω impedance, and are specified for less than 0.1% THD at 1kHz when producing 100dB SPL. On paper, the MM-100 is 2dB less sensitive than the MM-500, though in my tests they seemed very close in this respect.

The biggest difference in specified performance between the two models concerns maximum SPL, which is 120dB for the MM-100 and 130dB for the MM-500. Even 120dB SPL is less a valid monitoring level and more a form of self-harm, so if this is a significant issue for you, you might want to rethink your life choices.

### Taking Soundings

The most important thing, of course, is how they sound, and to my ears the MM-100 get impressively close to the subjective performance of the MM-500. That means they're open, clear, detailed and punchy, with a subtly forward upper midrange; if they were a pair of loudspeakers, you might say they have a slightly 'American' voicing. On some material, the MM-100 and MM-500 sounded pretty much indistinguishable. Where I could hear a difference, I felt that the latter were smoother in the 3kHz area, and perhaps a little richer below 250Hz or

so. But they are close enough that someone used to mixing on the MM-500 could pick up a pair of MM-100 and carry on where they'd left off, without it affecting their judgement.

In short, then, the MM-100s deliver at least 90 percent of the sound of the MM-500s, for less than 25 percent of the cost, which makes them a pretty compelling proposition. It also brings them into direct competition with some popular moving-coil models. If you're considering the likes of the beyerdynamic DT 1990 Pro, Sony MDR-MV1, Neumann NDH 30 or Sennheiser HD660S2, you'll regret not auditioning the MM-100 too. **///**

### summary

The MM-100s bring Audeze's and Manny Marroquin's signature sound to the masses at an extremely competitive price.

£ £399 including VAT.  
 T K&S Technology +44 (0)1903 768919  
 W www.audeze.co.uk  
 W www.audeze.com



# PIANOTEQ

TRUE MODELING

Award-winning physically modelled instrument for PC, Mac and iOS with authorized piano models from Steinway, Blüthner, Steingraeber, Petrof, Bechstein, Grotrian and Hohner.

Tweak the sounds in amazing ways by adjusting physical parameters.



STEINWAY & SONS

GROTRIAN.

C. BECHSTEIN

Blüthner.

ANT PETROF

Steingraeber & Söhne.

HOHNER.

# ORGANTEQ

TRUE MODELING

The release of Organteq back in 2019 shook up the world of virtual organs with a compelling, physically modelled, pipe organ at just 20 Megabytes.

After 4 years of research, the new major upgrade 2.0 continues to amaze by bringing a new collection of German Baroque stops, a vastly enhanced sound engine, new voicing parameters and powerful tools to tweak the sound to your preference.



Download a free trial version at [www.modartt.com](http://www.modartt.com)

Pianoteq and Organteq run on any modern laptop, Installation is simple and fast. Just connect it to your MIDI compatible keyboard and start playing.





# IK Multimedia Pianoverse

## Sample Library

IK's sampled piano instrument aims to be more than just world beating...

ATHEEN SPENCER

Boasting 'robot-assisted sampling' of the world's finest pianos, IK's Pianoverse aims to be 'the only piano instrument you'll ever need'. Full marks for ambition, then, but in a world that's not exactly starved of sampled pianos what does Pianoverse have to offer that others don't? Except for robot assisted sampling, of course...

At the time of this review there are five piano options available with three currently in development and more planned for the future. The pianos currently available for Pianoverse are the Concert Grand YF3 (sampled from a 9-foot Yamaha CFIII concert grand piano), the Royal Upright Y5 (from a Yamaha U5 upright), the Black Diamond B280 (a 9-foot Bösendorfer 280 Vienna Concert grand) and the NY Grand S274 (sampled from a 9-foot Steinway & Sons New York D-274 concert grand).

The most recent release at time of writing is the Gran Concerto 278, sampled from a 9.5-foot Fazioli F278 concert grand piano. Scheduled for release are the Hamburg Grand S274 (a 9-foot Steinway & Sons Hamburg D-274 grand), the Liberty Upright



(sampled from a rare Koch & Korselt upright grand piano) and the Black Pearl B200 (a 7-foot Bösendorfer 200 concert grand).

You'll need to download the IK Product Manager for installation, adding Pianoverse itself from the Software tab and then installing your purchased pianos from the Sounds tab. These pianos are not small due to the immense detail that has gone into creating them — they currently range in size from 24GB to 32.6GB (which required investing in yet another external drive).

Upon opening you're met with the browser menu, showing your installed pianos on the left and the presets to the right. There are 25 presets for every piano and each is tagged according to mood, genre and various other characteristics so that you can use the filter in the centre column to quickly find your perfect sound. You can also mark your favourites here for faster recall. User slots are only limited by the space on your hard drive.

### The Robot Finger

The first thing that strikes you about the main piano samples is how dry the recordings are. All pianos were sampled using close-range miking, either using DPA or AKG microphones. A mid-distance or coincident option was also captured using either Schoeps or DPA mics.

In order to accurately capture the full dynamic range of each piano, IK Multimedia developed a robot 'finger' to press on the keys at different velocities, with the data being fed back into their own, specially

created software. The robot had to strike the key in a manner that achieved maximum realism while fully capturing the dynamic curve of each note. This is a technique previously used by digital piano manufacturers, although in the interests of avoiding unnecessary sample content and taking up more hard drive space, the team chose the samples for each piano individually, adding the ones where a "just noticeable difference" was detected by the recording software and incorporating round robins, thus offering very playable pianos that don't use excessive processing power.

### The Piano Panel

Once a piano is selected, you'll come to the main screen, referred to as the Piano panel. The centre displays a representative image of the selected piano, with a visualisation of the notes depressing as you're playing them or running a MIDI track — always a great way of creating cheap YouTube videos.

The two menu panels at bottom allow fast access to master functions such as tuning, transposing, Space volume (more about that later), tone and compression. Also present >>

## IK Multimedia Pianoverse

### PROS

- Beautifully responsive sounds.
- Close mics make this ideal for jazz.
- Sostenuato and half-pedalling.
- Scalable GUI.

### CONS

- Not being able to blend mics.
- Lid position offers only a subtle difference.

### SUMMARY

All of the pianos are beautifully sampled with exceptional levels of realism that are only enhanced further by the mechanical sounds. Being able to drop these into the Pianoverse engine where you have equally impressive-sounding Spaces makes this a very enjoyable plug-in, not only to work with, but also to while away the hours playing just for the sheer fun of it.

### Purchase Options

You can purchase individual pianos or Pianoverse as a subscription that gives you access to every piano released and pending. Prices include VAT.

- €99.99 per piano.
- €14.99 monthly subscription.
- €179.88 annual subscription.

# Fireface UFX III

THE NEW STANDARD IN AUDIO PERFORMANCE



## 188-Channel, 24-Bit/192kHz high-end USB 3 Audio Interface

The Fireface UFX III is the center of any multitrack studio, handling up to 94 channels I/O with ease. Its unprecedented flexibility, compatibility, the inclusion of DURec (Direct USB Recording) and RME's famous low latency hardware and driver designs guarantee flawless operation in any mode and application.

Packed with professional features, including SteadyClock FS, MADI I/O (64 channels), a powerful DSP, USB 3.0 (full 94 channel I/O Class Compliant ready), TotalMix FX, Direct USB Recording, and support for the Advanced Remote Control USB (available separately), the Fireface UFX III is the professional's preferred tool for multitrack recording, mixing and mastering.



### Advanced DURec

Backup your recording with up to 80 channels simultaneously on your Flash Drive.

MADI

### MADI I/O

Unrivalled flexibility in connectivity and expansion.



### SteadyClock FS

Excellent performance in all clock modes and High Quality Analog Conversion.



### Low Latency Hammerfall X-Core

Maximum performance and ultra-low latency operation.

RME





▶ Thirty indoor and outdoor Spaces are available, some with adjustable parameters. ▶ Run three effects at once from the 10 available and modulate further with LFOs.

» here is a velocity curve, handy for bringing out that bottom-end growl if you're playing from a less-responsive controller. The second menu allows you to alter piano mechanics, such as hammer, pedal and key release noises. While mechanics have been included in other software pianos, the detail here really adds another level of realism.

To the right of the panel is a diagram of the three piano pedals — soft, sostenuto and sustain. These responded instantly to the digital piano that the software was being tested with, and for controllers that offer the option to have three pedals connected, you can easily allocate CC67 (soft), CC66 (sostenuto) and CC64 (sustain) to fully benefit from this feature. One of the most appealing aspects is the ability to use half-pedalling, which allows for a much more controlled performance.

### Choose Your Space

The next tab along on the top left takes you to the Space panel and it's here where things start to get really interesting. Having such dry piano samples means that you can easily drop them into different spaces and the result is that you have a very clean and realistic sound in whatever setting you place it in.

There are 30 spaces available. Indoor spaces include various studios, practice rooms, stages, cathedrals and more, which proved to be highly usable on the various test tracks. It's when you apply the outdoor spaces that things start to get a little crazy, with cinematic effects that include sand, ice and glitches. Some of the more complex spaces have additional settings that allow you to control the levels of these ambient elements.

### Tweak Your Sound

The Mix tab displays a channel strip that allows you to choose mic positions, set

EQ and compression plus fine-tune your Space. For the mic positions, you can select between close and either midfield or coincident, depending on the piano. Dropping the mic levels and the stereo width pushed the piano back into the reverb nicely to place it in a bigger space.

The tone can be adjusted using either 10-band graphic or four-band parametric EQ and you can choose between four different compressor types. There's Modern (VCA), Vintage (FET), British (modelled on the SSL G-Type Bus Compressor) and Vari-Mu (modelled on the Fairchild 670 limiter). EQ and compression can similarly be applied to your Space. If you're using PianoVerse standalone these options are a great addition and they really showcase the pianos to maximum effect when used within the presets.

A flip button here inverts stereo image, which makes a lot of sense as it switches you to being in the audience rather than listening from the perspective of the performer, although it can be a little disconcerting to play in this mode.

The final tab on the top left opens the effects panel, where you can select up to three global effects at a time from the 10 available, including saturation, drive and a granular delay. Effects can be further modulated using two envelopes and two LFOs. Just add Shimmer, Plate Reverb and more, combined with the outdoor Spaces, for some epic cinematic soundscapes.

Parameters within the Space, Mix and Effects tabs can be automated, plus you can right-click on buttons to assign CC controls.

### Testing, Testing

Testing it out fully was going to require working in a few different genres using the various pianos. The NY Grand in the Vintage Studio Space blended perfectly into a jazz trio setting, while the Black Diamond in

a Cathedral setting worked well for classical. While there's no felt piano available for more ambient pieces, there are plenty of options for muting the tones including closing the lid, and again Black Diamond worked well here.

As expected, pop and rock pieces benefitted from the brightness of the Royal Upright and adding a little chorus gave it more of a boogie vibe. If you're creating dynamic soundtracks then the Fazioli or Yamaha grand would more likely cut through the mix better, although you would probably want to bypass the internal effects and place the piano in the same space as the rest of your orchestra.

As a final test, I called up two other popular pianos into the DAW, gave them similar settings and used a digital piano as a controller. While the other two pianos are very usable, PianoVerse definitely has the edge and felt more alive and organic. It also has the added bonus of sostenuto, half-pedalling and an extra level of realism from the really well-sampled piano mechanics. While some might miss the ability to blend mics, it performed so well in each of the genres with the numerous editing options already available that it didn't feel as though it was lacking in this area.

If I had to pick favourites, it's a tough call but probably the NY Grand for jazz and the Black Diamond for classical, cinematic and ambient, but it is purely personal preference and each one of these pianos has its place.

Could it be improved in any way? As someone who likes to play for enjoyment it would be wonderful to have a binaural recording, and a felt piano would be a nice addition to the collection in future. But PianoVerse is already on its way to becoming the new favourite. **■■■**

£ See 'Purchase Options' box.  
W [www.ikmultimedia.com](http://www.ikmultimedia.com)

**NEW!**



**£644**

**Roland GAIA 2**

The GAIA 2 from Roland is a very versatile digital synthesizer with wavetable and classic waveform oscillators. **SYN0008810-000**

**NEW!**



**£1,640**

**Waldorf IRIDIUM Core**

With the IRIDIUM Core, Waldorf expands the Iridium family with the smallest member with the same power & performance. **SYN0008828-000**

**NEW!**



**Elektron Syntakt E25 Remix Edition**

**£959**

Elektron's versatile drum computer with hybrid sound generation, the excellent sequencer with parameter locks and MIDI tracks. **SYN0008846-000**

**TOPSELLER!**



**£785**

**Korg wavestate mk II**

The wavestate mk II from Korg transfers the famous wave sequencing synthesis from the Wavestation into a new age! **SYN0008752-000**

**TOPSELLER!**



**£1,514**

**MODOR DR-2**

Modor Music DR-2, drum machine, digital, 6 tracks, 18 synthesis algorithms, 64 drum kits, 96 patterns, reverse mode, parameterlocks. **SYN0008660-000**



**£2,379**

**Synclavier Regen**

The Synclavier Regen is much more than the modernized reissue of the NED Synclavier II from the 70s. **SYN0008563-000**

**TOPSELLER!**



**£3,490**

**UDO Audio Super Gemini White**

The hybrid synthesizer from UDO Audio is much more than two Super 6s in one housing. **SYN0008681-000**



**£2,400**

**Sequential Trigon-6 Desktop**

Polyphonic analog synthesizer in a desktop case - and the last real Dave Smith synth. **SYN0008768-000**



**£951**

**Teenage Engineering OP-1**

With no less than nine different synthesis forms, the OP-1 knows how to inspire its crowd of followers. **SYN0003986-000**





SAM INGLIS

Manufacturers of acoustic products aren't just competing with each other: they also need to offer something we can't easily build ourselves. When it's so cheap to pop down to your local builder's merchants and pick up a few slabs of Rockwool, commercial makers need to differentiate their products from simple DIY options. They can do this by offering better performance, smarter appearance, greater convenience or a design that can't easily be home-made. And with their new SlatFusor line, GIK seem to have achieved all four things.

### Absorption & Diffusion

In general, acoustic treatment employs two basic mechanisms: absorption and diffusion. For a typical small studio, absorption is the more relevant. Small spaces have inherent low-frequency

# GIK SlatFusors

## Acoustic Panels

GIK's ingenious new design provides both absorption and diffusion, at a highly affordable price.

issues relating to the room modes, and the best way to tackle these is to absorb or 'trap' the bass energy that would otherwise excite standing waves in the room. This can be done in several ways. Basic panels and corner traps are usually little more than a block of mineral wool in a covered frame. These are easy to DIY and can be effective over a wide frequency range, but in order to achieve much at low frequencies, you'll need a lot of them. An alternative is to use tuned devices such as Helmholtz resonators or limp-mass membrane absorbers. These

provide more space-effective absorption that is targeted at specific problem frequencies, but they are not trivial to DIY.

Diffusion or scattering tackles a different acoustic problem. When we put in enough absorption to properly control the low frequencies, it's very easy to over-damp the midrange and treble, leading to a room that sounds muffled and dull. It's important to retain hard surfaces to reflect the right amount of midrange and high-frequency energy back into the room. However, flat walls tend to produce a few discrete echoes, when what we want is a more diffuse reverberation made up of many small reflections. Diffusors can help to break up and scatter the reflections and deliver the kind of benign reverberation we're after. There are many different designs, but what all of them have in common is that apparently trivial details tend to be crucial to their effectiveness. What looks like a random arrangement of dowels, holes or slats is actually a mathematically generated structure that needs to be built exactly to specifications in order to have the correct properties. So, although it's possible to create DIY diffusors, it isn't easy.

If you're creating a studio space from scratch, one popular approach is to build the absorption into the walls, which can then be faced with a porous diffuser of some sort, so that the wall itself acts both as an absorber and a diffuser. But if you're converting an existing room, the absorbers have to be inside the room, so the more absorbers you have, the less wall space remains for diffusors or other reflective surfaces. Unless, that is, you use GIK's SlatFusors.

### Slat Happy

The basic idea behind the SlatFusor design is clever and conceptually simple, but probably not easy or cost-effective for most of us to DIY. In essence, it's

■ The SlatFusors are available in several depths to suit different environments.



an absorbent panel fitted with a front face that is both an effective diffusor and, to some extent, a membrane absorber. Different sizes and depths are available, and whereas basic absorbers tend to work best when spaced away from the wall, GIK say their tests show the SlatFusors are most effective when placed directly on the wall. So, for the loss of a few inches in depth, ordinary walls gain two useful acoustic properties when SlatFusors are hung on them.

The SlatFusors are available in four different depths — 25, 50, 100 or 150mm — and as square 600mm or rectangular 600 x 1200mm panels. I went for the 150mm version of the latter. Note that the nominal depth refers only to the absorptive panel: the diffusor adds another 30mm or so in front.

SlatFusors are manufactured to order and delivered by a standard courier service. The entire process is impressively fast. The build quality of the review SlatFusors was impeccable, and certainly far better than I could have achieved with my limited DIY skills. The wooden frames housing the absorption are rigid and precisely constructed, and neatly faced with black fabric that is held in place using staples. The diffusion on the front panel is effected by slats spaced at regular intervals along a flexible baffle made of high-density felt. This material is carefully chosen so as to not only allow sound energy to penetrate to the absorptive material inside, but also to provide an element of limp-membrane absorption.

If you order multiple SlatFusors, the necessary fittings are supplied all together in one of the boxes, along with a generic instruction manual that covers installation of all GIK products. Several different hanging and mounting systems are used for the various panels in the range. In the USA, the SlatFusors come with 'sawtooth' hangers, whereas units sold in the UK and Europe are supplied with 'French cleats'. These are a neat and unobtrusive way of mounting panels on a solid wall: basically, you get two bent pieces of metal, one of which is attached to the wall and the other, inverted, to the rear of the panel at the top. The cleat on the panel then simply drops into the wall-mounted bracket and a combination of gravity and friction keeps your panel securely in place. There's scope for adjusting the left-right position of the panel after installation, but you need to

make sure you get the vertical alignment right first time.

You need to attach cleats to panels yourself, which involves drilling into the frame, and could perhaps benefit from slightly more detailed instructions. The cleats each have four holes, but only two screws are supplied or needed. I found in a couple of cases that holes were blocked by the staples used to attach the fabric, so it was useful to have the options. Note that if you plan to mount several SlatFusors together, it's important to attach the cleats to the same end of each of them — the back is symmetrical, but the front isn't, and you want to make sure the pattern of slats is continuous from panel to panel. (Ask me how I know...) With a certain amount of huffing and puffing I was able to mount the SlatFusors on my own, though it would have been easier with a second person.

### Peak Performance

Unlike DIYers, commercial manufacturers of acoustic products can and should provide measurement data from an accredited laboratory. GIK have been very diligent in this respect, and full test results from the University of Salford are available separately for the 25mm, 50mm, 100mm and 150mm-deep versions. As you'd expect, the main differences concern the low frequencies; the 50mm version offers maximum absorption around 500Hz, with limited effectiveness below 200Hz, whereas the absorption coefficient of the 150mm version peaks at 125Hz and is still above 1 at 100Hz, suggesting it's doing the most work in the range that is most problematic for small studios.

Another advantage of buying through a company like GIK as opposed to going down the DIY route is that they have acoustics specialists on staff who are able to offer professional advice and recommendations. I was aware that efforts to treat the low end in my own space had made it a bit too dead, without fully taming the bass. Simply installing yet more absorption would have made the midrange issues worse, especially as the hard floor is in a poor state and needs to be covered with rugs. There's nowhere to easily fit panels behind the listening position, so GIK recommended installing SlatFusors on the front wall behind the monitor speakers.

There are usually multiple factors at play in any change you make to a studio,

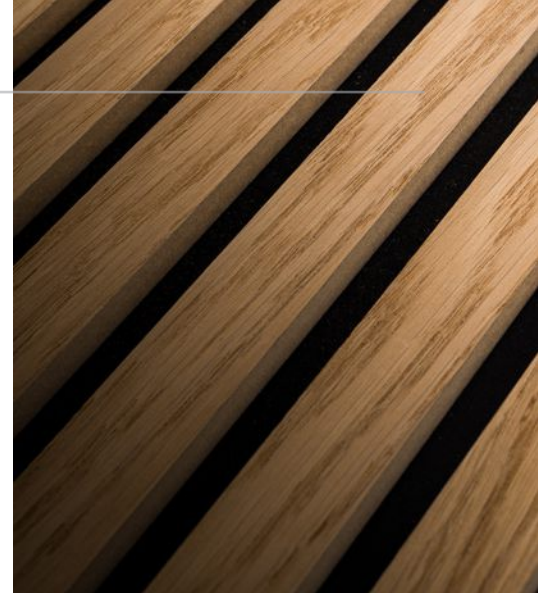

■ The slats themselves are backed by a sheet of high-density felt which provides some resonant absorption.

and in my case, fitting the SlatFusors also meant I had to slightly reposition my monitors. But the cumulative effect was impressive, and measurable. I used Genelec's GLM software to generate reports before and after the process, and the 'after' results were substantially better, especially in the 80-200Hz region. The room still benefits from EQ correction within GLM, but the degree of correction required is noticeably less, and a couple of sharp notches disappeared from the graph. The SlatFusors did exactly what they're meant to do, helping to control the low end without over-damping the midrange. They also look a lot smarter than the wall they're hanging on!

With the SlatFusor, GIK have managed to put together a single product that combines both broadband and tuned absorption with an effective diffusor. Just a few will be enough to make a real difference in most rooms, especially if you have space for the 150mm version, but at the same time you can install as many as you like without the risk of over-deadening the midrange and treble. Perhaps most impressive of all is the cost. Even if you had the patience and the skills to build something like the SlatFusor yourself, I think small-scale DIYers would struggle to obtain the raw materials for all that much less than GIK's full retail price. Save yourself the time and effort, let GIK do the hard work, and get on with making music! ■■■

### summary

The SlatFusor is an effective, smart-looking and highly affordable acoustic treatment product that cleverly combines absorption and diffusion.

£ From £102 plus shipping; SlatFusor 6S as reviewed £238.80. Prices include VAT.

W [www.gikacoustics.co.uk](http://www.gikacoustics.co.uk)



# Line 6 HX One

## Effects Pedal

Why clog up your stage with effects you only use briefly? Line 6's new stompbox can be any pedal you want it to be, and will fit neatly into any pedalboard setup.

PAUL WHITE

Some 12 years ago, Line 6 launched the M5, a multi-effects pedal that had a wide repertoire but produced only a single effect at a time. It proved a useful format, because although larger M-series pedals could create several effects at once, the more compact M5 found a home on many pedalboards, for providing effects that might be used in only a few songs. For example, you might have a couple of songs that need a fuzz box and another that needs a rotary speaker or a multi-tap delay. Or perhaps for another you require a Uni-Vibe clone. Since such effects would get used for only one or two songs each, it isn't worth



### Line 6 HX One

£249

#### PROS

- Huge range of Helix-quality effects.
- Straightforward user interface.
- The Flux feature is very useful in a live situation.
- Mono or stereo operation.
- Compact.

#### CONS

- Small display won't be ideal for everyone in a live situation.
- Pitch effects not as refined as those in dedicated pitch processors.

#### SUMMARY

The HX One confirms that the M5 concept was a valid one, and builds on it by offering better-quality effects, a more compact format and by adding the Flux feature, allowing you to morph between parameter settings at a user-defined rate.

buying — or allowing pedalboard space for — a dedicated pedal.

Towards the end of last year, Line 6 revisited that format with the new HX One, an even more compact 'one at a time' multi-effects pedal, packed with over 250 HX effects that are based on the latest Line 6 Helix technology. The HX One can be used in mono or stereo and has a TRS expansion jack for the connection of one expression pedal or a dual footswitch to augment the two onboard footswitches. There's five-pin MIDI in and out/thru, and a USB-C port for firmware updates. Power comes from an included 9V, 500mA adaptor. The pedal can be locked to MIDI Clock and a Mac/Windows editor/librarian (not yet available at the time of writing but expected soon) will connect via USB. If you only need mono operation, the remaining two jack connectors can be used as sends and returns to patch the pedal into an

amp's effects loop. While few guitarists might be in a position to benefit from the stereo facilities in a live performance setting, stereo in and outs will certainly be appreciated by keyboard players, and I can also see the HX One being embraced by the modular synth community.

#### Practicalities

This new pedal has a robust cast-metal case, in which the I/O jacks, power adaptor and USB port are located on the top edge to conserve pedalboard space. The MIDI sockets are on the left and the expression jack on the right. A small but pin-sharp monochrome OLED display shows preset and parameter names along with horizontal bar displays that show the parameter amount. As a parameter is being adjusted its value is displayed, and it is possible to toggle the displays to show note values, milliseconds or Hertz.



■ The HX One supports stereo I/O, but if used in mono the second I/O pair can be used as a send/return loop.

Operationally, the HX One follows a familiar paradigm, with the three knobs below the display adjusting the parameters shown above. However, these knobs are actually turn and press encoders and are used to support a new feature called Flux. We've seen a similar concept employed on Eventide's pedals and plug-ins: the user can morph between one set of parameter values and another within the same preset. Flux allows the users to set the in and out speeds and curves, and its settings are stored within the preset. That means it could, for example, be used in one preset to switch a rotary cabinet emulation from fast to slow with suitable ramp times, while in others it might allow the depth of a modulation effect to increase or a drive pedal to pile on more drive and perhaps a bit of level for those inevitable guitar solos.

Another press/turn encoder is used to select the effects or to step through presets, and there are arrow buttons on either side that are used for effect selection, navigation and to step to a new page of controls if the current effect has more than three adjustable parameters. Other than that, there's a Home button that always gets you back to displaying the current preset, and the two footswitches.

In normal use the leftmost switch acts as a bypass and its status LED changes colour to indicate which effect category is currently in play. For example, it shows purple for filter, pitch and synth effects, green for delay effects, dark orange for reverb and light orange for distortion. When bypassed, the LED dims but still shows the appropriate colour. The rightmost switch can be used as a tap-tempo or be pressed and held to enter Flux mode, in which case the sounds transitions between the two sets of effect parameters when the switch is pressed, then reverts when the switch is pressed again. In tap mode its status LED pulses red at the tap rate, while in Flux mode it goes from dull white to bright white and a bar moves along the top of the display to show the Flux transition taking place.

To set up Flux mode, it's necessary only to adjust the controls and then press them to lock in the values to the current Flux setting (bright white light or dim white light). Then you switch to the other Flux setting and follow the same routine to set the alternative parameter values. The Page buttons takes you to the Flux On and Off time settings as well as adjustment of the transition curve shape.

As with the old M5, you can step on both pedals at once to change the footswitch mode to preset up/down buttons, and helpfully you can also set it so that you only step around your chosen effects rather than the whole

»

# SONTRONICS® SATURN RETURNS



The stunning new SATURN 2 takes our microphone know-how to a whole new level with its super-smooth top end, beautifully linear response and incredibly low self-noise. It is our most flexible mic ever, with nine (yes, nine!) polar patterns plus filter and pad controls, and it gives outstanding results on vocals, all instruments, ensemble and overhead recording. SATURN 2 is truly out of this world!

[www.sontronics.com](http://www.sontronics.com)



» preset repertoire. In preset up/down mode you can see the current preset as well as the preset to either side of it in the display. If you don't want to keep switching between bypass and preset select modes, you can set up a dummy preset with the mix at zero and then use that as your bypass preset, and just stay in preset up/down mode. However, it might have helped if a dedicated bypass preset was available for this purpose from within the effect types. Pressing down and holding both pedals brings up a tuner mode.

The effects are grouped into familiar categories: Distortion, Dynamics, EQ, Modulation, Delay, Reverb, Pitch/Synth, Wah Filter and Looper, the latter offering mono or stereo options with normal or Shuffling modes. In Shuffling mode you have adjustment of the Slices, Sequence Length, Shuffle, Pitch, Reverse, Repeat, Smooth, Drift, Playback and Low/High Cut, so it's possible to set up some seriously experimental loops with granular-style overtones if you are that way inclined. The simple looper offers basic playback and overdub level controls as well as low-/high-cut filtering.

In the Distortion section, you'll find a very broad selection of boosts, drives, distortions and fuzzes including Klon and Fulltone OCD inspired effects. Dynamics offers a wide assortment of classic compressors, a couple of noise gates and a useful slow attack effect. EQ includes basic, parametric and graphic variants but also features an acoustic guitar emulation, while Modulation runs the gamut of phaser, flanger, chorus and tremolo options as well as a couple of rotary speakers, a Uni-Vibe type effect and even ring modulation. Delay covers the usual analogue and digital variants both with and without modulation and multiple taps. The more specialist delays include ducking delay, reverse delay, slow attack delay, pitch echo, glitch delay and ADT treatments.

Move on to the Reverb section and, once you get past the usual rooms, halls, plates and springs, you'll find specialist treatments such as Particle Reverb, Searchlights, Shimmer, Octo and Glitz. It's the same story when you get to Pitch, as in addition to both mono and poly pitch-shifters you'll find auto harmony, whammy emulations and a number of monophonic pitch-tracking synths, which can sound very impressive as long as you play cleanly. In the Wah Filter section

— The MIDI DIN sockets are found on the right-hand side panel.



— On the left, there's an expression pedal input.



are various types of wah pedal, which really benefit from an expression pedal to make full use of them, plus auto-filters such as emulations of the revered Mutron, a talkbox and pulsing filters.

In most cases, the effects are of very high quality and provide close emulations of their inspirations. There's enough adjustability to fine-tune the sounds the way you like them without getting too bogged down with a huge number of parameters, and that Flux feature really is a big deal when it comes to live performance. If there's a weakness, it's that the polyphonic pitch-shifting isn't always as smooth as you might enjoy from a dedicated pitch-shift pedal, and that's something that carries over to the shimmer reverb, which sounded just a hint brash if used at a high mix value. Even so, when mixed in at an appropriate level, and perhaps with a little high-cut filtering, the pitch processing gets the job done, whether it's a spot of pitch-sliding whammy you need or a 12-string emulation.

overdrive, the Line 6 HX One represents exceptional value for money, and it could definitely help players simplify their pedalboards by providing the necessary 'wild card' effects to go with their existing core pedals. On a practical level, the only shortcoming I can find is that, with the pedal on the floor, it can be difficult to read the small display. Some way of toggling the display mode so that the current patch name fills the whole screen would have helped (you may not need to adjust parameters in a performance situation). The same goes for the preset up/down switch mode, which uses even smaller text. Having a different coloured status LED for each effect type helps, but only if your effects fall into different categories.

Those very minor gripes aside, the HX One is a very worthy successor to the M5L: it's the same concept, but it offers better effects, the hugely useful new Flux feature and a significantly smaller footprint. **///**

## Final Thoughts

Given that you can spend just as much or more on a 'single trick' boutique

£ £249 including VAT.  
T Yamaha UK +44 (0)344 811 1116  
W <https://uk.yamaha.com>  
W <https://line6.com>

# Your dream console is here.

Console 1 Channel Mk III lets you use your hands to mix and your ears to sculpt your sound. Each knob corresponds to a specific parameter and no mapping is necessary. The dual high-resolution smart screens keep you focused on the sound of your mix. Intuitive and efficient, Channel lets you go deeper into your creative process. Discover your dream console. Discover Console 1 Channel Mk III.



Console 1 Channel Mk III. The sound and feel of big studios.





# How I Got THAT SOUND

## Colin Elliot • Izo FitzRoy 'When The Wires Are Down'

JOE MATERA

From his Sheffield recording studio Yellow Arch, producer, musician, arranger and programmer Colin Elliot has worked with an illustrious list of musical artists. These include Kylie Minogue, Jarvis Cocker, Duane Eddy, Paul Weller, Slow Club, Hoggboy, My Darling Clementine and Richard Hawley. Asked to recall a favourite sound from the innumerable projects he's recorded, he settles on Izo FitzRoy's 'When The Wires Are Down'.

### Out Of The Box

"We started off Izo's album by tracking the drums in my booth. It is a really small, tightly padded room, and it sounds great, if you want that kind of hip-hop sound, that really tight chunky drum sound. So, we had already done the first nine songs

for the album in the booth. Izo's drummer, Sam Walker, is a fantastic player, really musical. He plays really lightly, and generally doesn't hit hard at all, he just makes everything work by tapping. But when it came to tracking this song, 'When The Wires Are Down', it needed a big dramatic sound. So after having tracked drums for four or five days in the booth, we brought the kit out into the live room.

"I used a pair of [Neumann] KM184s over the top of the kit, and then I placed a pair of Royer R121s in the room about 10 feet away. Then it was a question of just balancing those two things up. So, I took the overheads and the room and rammed them together into my UREI 1176-2 compressor. All the transients from the hits get squashed down, and the ambience of the room pings out.

"It really shows off the acoustics of the live room at Yellow Arch; there's virtually no reverb added. On the final mix, I sent some of the snare channel and the overheads to a [Logic] Space Designer reverb, but the return fader is only just off the bottom. It is the sound of the room that comes out, and the room sounds fantastic."

### Playing To The Room

"What I like about the drum performance on this track is Sam's musical response to having that sound fed back to his mix

### Hear The Sound

W [www.youtube.com/watch?v=IFQGsvAGJ2k](https://www.youtube.com/watch?v=IFQGsvAGJ2k)  
W <https://open.spotify.com/track/0ic6dYVN2t8yAgzkkThTk>



while he's playing. You can hear that he is tapping, and then when he needs to, he'll hit a really dynamic flourish. There is one bit in the second verse where he's doing virtually nothing — he's hitting a back beat on a rim shot, just tapping. And then at one point he just whacks the floor tom. It's one hit, but there's something about it that made us all go 'Yes!'

"And when he needs to, he really swells, doing fills or hits on the snare and on the toms, and you can hear the room responding. The sound fed his performance. I think if I had just given him a dry sound, he wouldn't have played the way he did. So, the room inspired the miking technique, and the compressed sound fed back to him inspired his performance, which then set the tone for the rest of the song and arrangement and led to the atmospheric and — I hope — dramatic final result." **///**

# Sonicview

The New Way of Mixing.



 Dante®

 VIEW

Visual Interactive Ergonomic Workflow

**Sonicview 24 | Sonicview 16 | SB-16D**

Digital Mixing Consoles with Multi-Environment Touchscreens

You asked for a digital mixing console for studio, touring, fixed installation and broadcast. You asked for the latest technology for superior sound quality and reliability, flexibility and intuitive, easy-to-use touchscreens

and assignable buttons. You wanted Dante capability with a matching stagebox, as well as many connection and expansion options up to 32-track recording.

We heard you.

The new **Sonicview** from Tascam – mixing rethought.



All info: <https://tascam.eu/r/fv6P>



**TEAC UK Limited** Luminous House | 300 South Row | Milton Keynes | Buckinghamshire MK9 2FR | UK  
Sales Office Tel: +44 (0) 1923 797205 | E-mail: [peter@tascam.co.uk](mailto:peter@tascam.co.uk) | [www.tascam.co.uk](http://www.tascam.co.uk)

© 2023 TEAC Corporation. All rights reserved. All specifications are subject to change without notice.

**TASCAM**





# Ableton Live 12

## DAW Software

Live 12 introduces a raft of new features, devices and general improvements.

NICK ROTHWELL

Hot — or at least warm — on the heels of the latest version of the Push controller (*Sound On Sound*, July 2023) comes a new version of Ableton’s flagship DAW, right on time for the roughly three-year refresh cycle. The much-trailed new feature is support for alternate tuning systems, but there’s also a bunch of improvements to Live’s interface, some nifty new editing features and a handful of brand-new devices.

### Interface Improvements

Live has always had a pretty regimented idea of what should appear where in

its window (or both windows, if used in two-window mode). That regime has been broken down a bit in Live 12. For a start, the mixer view from the Live Session can now be shown in the Arrangement, a design move that makes such obvious sense one wonders why it wasn’t done before. And — sacrilege! — you can view a track’s device chain and selected clip at the same time. Try to do both of these things at once and you’re probably going to run out of editing space on a laptop screen, unless you scale the view down and have very good eyesight, but on even a modest external screen these are clear usability improvements.

Navigating around a Live Set has been made easier too. There’s a new Navigate menu that exposes keyboard shortcuts for selecting the main areas of the interface, and various Tab key combinations that then walk around controls within each area: along the control bar, up and down the controls in a mixer channel, and so on — or even within a single device. I’m a fan of keyboard navigation, but there’s so much on screen in a Live project that I’d probably wear my Tab key out if I tried to use it exclusively to navigate. You will probably end up learning a handful of shortcuts and then switching

back and forth between keyboard and mouse while working.

### Browser

Live’s browser has had a big revamp. A major new feature is filters: each filter is a set of on/off tags for specific characteristics of many types of object within Live, from an entire Live Set all the way down to a single clip file. The actual filters available change depending on the type of object: for samples the tags include content (sample or video), type (loop or one shot), category and character of sound, and so on. For plug-ins the content tag can be device or preset (although plug-ins rarely export presets to Live unless you save them to disk), and there are tags for properties such as format (AU, VST2, VST3) and creator (the vendor).

At every stage the filter is being applied to the root selection (in Library or Places) in the left column of the browser, not the actual item selected on the right. And in any specific library location or place, the tags are gently highlighted according to whether there are any items at all that match them, according to the current active filter, guiding you to finer searches with more tags.

Filters can be edited, so that you can add your own tags — the editing pane is also where you get to change which tags are enabled on the selected object. I added my own name to some Max For Live devices I've created, and was pleasantly surprised to find that I could move a device from one folder to another without its tag disappearing. The tagging appears to be done by name: change the name and the tags vanish.

I don't know whether I will spend an afternoon at some point going through all my projects adding tags — I suspect not — but I found it immediately useful to filter plug-ins by format, to make sure I was consistently using the VST3 versions rather than VST2 or AU, since Live 12 no longer groups the different formats into folders. Tagging entire Set files might well be useful for some workflows.

For a more contemporary take on searching, presets and samples support 'Sound Similarity' searching, using tags and neural net analysis to list content deemed similar. Results varied from spookily similar to vague approximation, so at the very least another way to influence your creative choices.

Live still features 'collections', which are coloured labels attached to objects. These seem to be orthogonal to the new tagging machinery. Select a collection by colour, and its contents can still be filtered. In any view, filtered or not,

collection colours are shown against the items.

One thing I found myself wanting to do was search the currently loaded Live Set or Project for devices it was using — useful for swapping out those obsolete VST2 or Intel-native plug-ins — but this seems not to be possible for anything embedded in a Set, except for Max For Live devices, which exist separately on disk. Other DAWs do allow searching and listing of currently loaded devices, and I miss that feature in Live.

Tags are global, and appear to be stored in the application's preferences folder, so if your tags are important, be sure to back them up.

## Modulation

One of the prime features of Max For Live, apart from generating and processing MIDI and audio, is its ability to control the Live Set that it runs inside. This enables you to build and use modulation sources like LFOs and envelope followers, and attach them to controls in other devices in the Set, or even mixer controls. Until now, this feature came with a down side, in that it wasn't doing modulation in the true sense at all, but something akin to automation take-over. A parameter under the influence of Max For Live could be changed in value, but the value would be changed permanently. This would potentially mess up any preset being

saved, and also preclude any kind of manual update or automation of the same parameter. (You might, for example, want to have a long slow automation lane to open a filter, while also applying some LFO modulation.)

'Real' modulation already exists in Live: clips can contain envelopes which either modulate or automate parameters in a track's devices or mixer. But now, Max For Live can do proper modulation as well, offsetting a parameter from a base value. This modulation can be unipolar or bipolar, and its presence is indicated by a green dot next to the parameter being affected. It is possible, as the illustration shows, for a parameter to be under

## Ableton Live 12

£539

### PROS

- User interface improvements, including a new content browser.
- Support for scales and alternate tunings.
- MIDI generators and transformers.
- New devices, plus some Suite-only devices making their way into the Standard edition.

### CONS

- Scale and tuning support not totally supported in Max For Live.
- Alternate tunings only work in plug-ins that support MPE.

### SUMMARY

The latest version of Ableton Live offers alternate tunings, new devices, a better browser, new MIDI processing tools and a clutch of interface enhancements.

both automation (red dot) and modulation (green dot) control at the same time.

I discovered that it is also possible to modulate a parameter with a clip envelope and a Max For Live device at the same time, and the effect appears to be a combination of the two, but a parameter cannot be controlled by more than one Max For Live device. (I'm sure some kind of clever modulation-mixing device could be built if there were some demand for it.)

Plug-ins can have modulation applied to them as well, but this is just treated like automation, and changes the actual value of any parameter being controlled, no doubt a restriction of the current plug-in standards (VST and AU). If Ableton ever support the newer CLAP plug-in format, the problem might well go away for some plug-ins at least.

## Scales & Tuning

Live is now scale-aware, in that clips and MIDI effects, as well as some devices, can have their notes constrained to a particular scale rooted in a particular key. Click a toggle in the control bar and that scale will be the default for clips and devices (and the new MIDI Tools, described below). Clips will show the active scale in the piano roll, and you can hide MIDI pitch rows which aren't in that scale. MIDI devices can follow the current scale as well: the Scale device is a natural contender here, able to constrain notes to the current scale rather than one set in the device itself; the Arpeggiator can do this also.

At this stage I started to wonder how I would go about writing a track

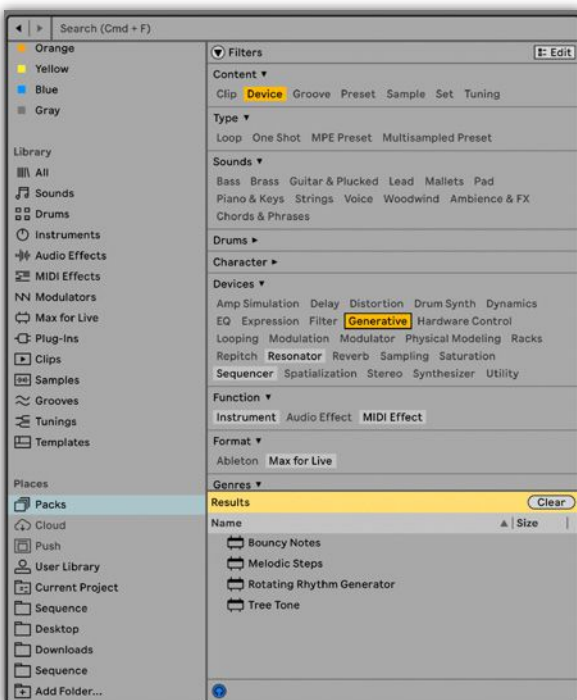

Filtering by content and device type.







■ The global scale setting in the control bar.

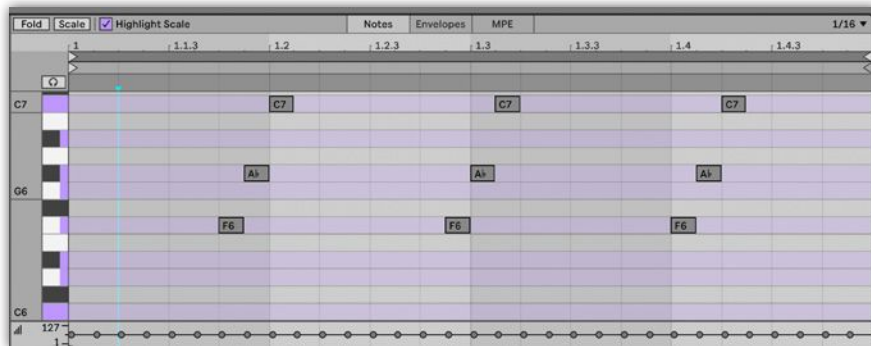

■ The current scale highlighted in a clip.



■ Scales activated for two MIDI devices.

» which modulated key part way through, a technique not unknown even in modern popular music. Even though the main scale selector is shown prominently in the control bar, this setting tracks the scale property of the selected MIDI clip. When a clip is launched in the Session, or starts playing in the Arrangement, its particular scale (if any) takes effect and is imposed dynamically on any devices in the track which are set up to use scale selection.

Instruments can potentially make use of scale information as well, although to date Meld (see below) is the only one to do so. When it's in scale mode, Meld's two oscillators can be tuned in scale degrees rather than semitones, so that (for example) four scale degrees in C major delivers a flat fifth on the B but a perfect fifth elsewhere, as per the scale. Meld's filters are also scale-aware: the plate and membrane resonators will track scale pitch, at least to an extent.

Older instruments, such as Operator, Drift and Analog, have no awareness of scales themselves, although they will play scale-aware clips. Max For Live also has

no awareness of the scale system, at least for now — I'd expect that to change in short order.

Live's support for scales results in MIDI notes being filtered or shifted by semitones as they are processed, but has no impact on the actual frequencies

associated with the notes: by default, everything is in equal temperament with an A above Middle C of 440Hz. You are welcome to detune individual instruments, and many third-party plug-ins and hardware instruments support alternate tuning systems, but it's rare in DAWs — a quick Google search suggests that Apple Logic Pro is the only other major platform to offer global tuning to date, although Bitwig Studio has a device for generating microtonal note pitches.

This omission seems odd when you consider that the standard equal temperament tuning system is a 400-year-old compromise which allows a single tuning to support music written in any key while guaranteeing the same frequency intervals between notes, the cost being that the harmonic intervals are slightly out of tune. Retuning a physical instrument between songs is not very practical (for keyboardists anyway; guitarists do it), but retuning a software instrument, or a digital hardware one, should be straightforward and immediate. In the West we are used to equal temperament and perhaps don't fully realise what we're missing, but a listen to Bach's *Well Tempered Clavier*, in which a piece of music in every possible key is played in a single tuning where note intervals differ between keys, serves to refresh the ears. For more modern and radical tunings, check out the work of Wendy Carlos, Arnold Schoenberg and Conlon Nancarrow.

This discussion skirts the issue that standard 12-note-per-octave tunings dominate in Western music to the detriment of other tunings in the world.

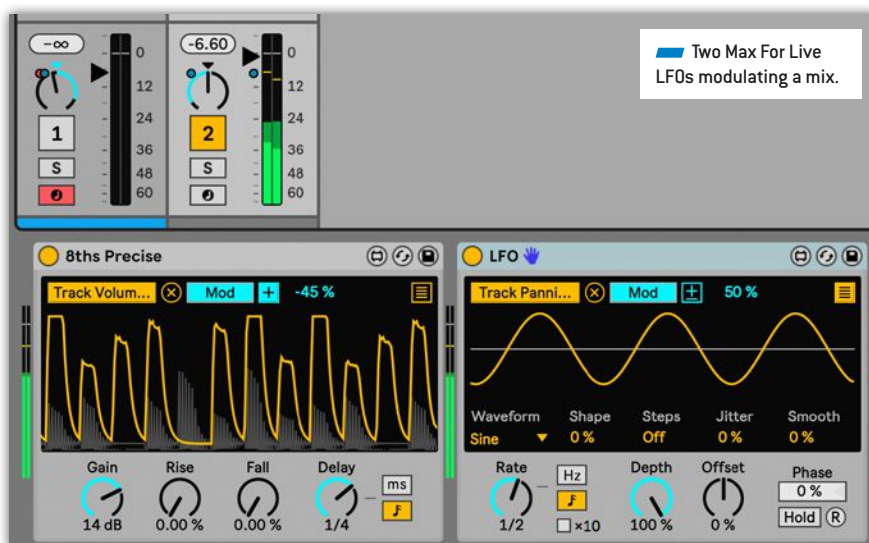

■ Two Max For Live LFOs modulating a mix.

Tools which support other tuning systems are supporting musicians whose creative work is potentially compromised by the traditional equal scale — and opens a door for us to experience and experiment with such musical ideas too.

Live 12 supports arbitrary tuning systems (in other words, mappings between incoming MIDI note numbers and frequencies). All of Ableton's instruments are able to adopt a Live Set's tuning, and Live seems able to cajole MPE-capable third-party devices to retune themselves as well. (ROLI Equator 2 followed Live's tunings accurately, at least to my ears.) For non-MPE plug-ins, you're probably out of luck, unless the device can be retuned independently.

Live's browser allows a single tuning at a time to be activated in a Live Set, although it can be customised or disabled per track. The tunings are tagged and can be searched by filtering. There is a selection of Arabic maqam scales, some just intonations (12 notes per octave and above), a selection of EDO (equal division of the octave) tunings, and Wendy Carlos' three experimental tunings (alpha, beta and gamma), which are notable for not having repeated octaves. You can also add your own tunings as Scala files — there is at least one web-based environment for designing and exporting files, which Live 12 seems to read without any problems.

If you work with Max For Live, direct tuning system support is absent (although I would expect this to be remedied before too long), but if your device is MPE-capable then Live seems to treat it like any other MPE device and sends per-note pitch variation to produce the correct pitches in the current tuning. A quick bit of Max For Live programming seemed to confirm this, and I tested the MPE-capable Granulator III (see below) with various alternate tunings: it seemed to match the pitches correctly.

### New Devices

Live 12 Suite sports two major new native devices — one instrument, one effect — plus the return of a Max For Live favourite. The native devices fit into the 170 pixels of height afforded by the device view pane, but also have an expanded view which houses each device's modulation matrix. The idea of a mod matrix as first class citizen is relatively recent: of Live's instruments, only Wavetable (which arrived in Live 10)

has anything similar, and the matrix there doesn't feature in the expanded view. I'm personally all in favour of modulation getting a more prominent billing.

But we're getting ahead of ourselves. The new instrument is called Meld, and Ableton's release documentation doesn't really categorise it. In fact, its architecture is relatively conventional: two voice paths layered in parallel, where each comprises an oscillator and filter, with envelopes, LFOs and a tone control. So far so straightforward, although the design does, as Sherlock Holmes might say, present some points of interest. There is a choice of 17 different filter algorithms, including phaser, comb, vowel and two resonators. The first of the two LFOs for voice has a dedicated 'effects' section for shaping, forming a little modulation system of its own before the main modulation matrix comes into play. And most notably, the oscillators are, in a sense, semi-preset: you pick one of the 24 oscillator types from a menu, and then have a grand total of two macro knobs to customise what that oscillator does (over and above the usual octave, semitone and cent tuning controls). The names assigned to the

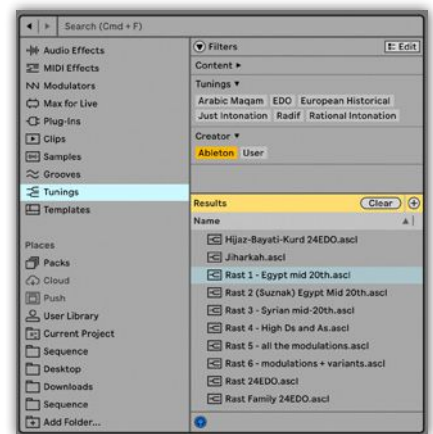

Some tunings in the browser.

macros change depending on oscillator type (although they're currently still referred to as 'Osc Macro 1' and 'Osc Macro 2' in the modulation matrix).

I've summarised the different oscillator types in the 'Meld Oscillator Types' box. They include a selection of basic waveforms, granular sources over different waveforms, noise, square wave with hard sync, a few varieties of two-operator FM, a warbly chip-tune source, a climbing (or falling) Shepard



# PSP Vintage Warmer

morphing  
bytes  
into  
emotions!

www.PSPaudioware.com





Meld, with its oscillator types and modulation matrix.

» tone, and more. They are all smooth and rich-sounding, and surprisingly versatile given the minimal number of controls. And for extra fatness (as we used to say in the 1990s) there's a unison mode, with voice spread available as a modulation source.

At first I thought the 'preset' nature of the oscillators would be a serious restriction, but each type is well-crafted in terms of its macro control, and the multi-mode filters downstream are more than flexible enough to provide powerful sound shaping. The LFO modulation system is sophisticated, and, as a bonus, the envelopes can be looped, so it only takes a bit of messing around with the modulation matrix to get into moody VCS3 territory, if that's your thing. Dial up FM for both oscillators and you're effectively doing a subset of four-operator FM. Use the voice paths separately for attack and sustain parts of your sound and you're into the once-fashionable 'linear arithmetic' layering of the Roland D-50. Overall, I like Meld a lot — it looks simple, but its well-crafted component parts quickly assemble themselves into surprisingly versatile generators of sonic material.

### Roar

The Roar effects device is described as providing colouring and saturation. It consists of three waveshapers, each of which is equipped with a dedicated filter which can be positioned pre- or post-shaper. The shapers can be arranged in a number of different signal paths: single, serial, parallel, multiband, Mid-Sides, feedback — a handy little layout icon and some dedicated level

meters show what's going on. Oddly, multiband is the only mode where all three shapers are available — in the other modes, it's just the first two (and in the case of 'single', just the first one). The waveshaper configurations range from the tried and tested (tubes, preamps, rectifiers) to the gritty ('digital clip', 'bit crush') to the outlandish ('fractal', 'tri fold'). The filters are particularly versatile, from the usual low-, medium- and high-pass to

a nice multi-mode morphing configuration, a comb filter and one for aliasing-packed sample-rate reduction. More shaping is provided by drive and tone controls upstream of the waveshapers, while a shared audio section with band-pass filter and delay is routed in to provide feedback options. A compressor at the end of the audio chain allows the final signal to be reined in if required.

I have to admit that I'm not a massive fan of digital waveshaping, and have never bit-crushed anything in my life, much preferring subtle and soft saturation effects. Many of the Roar presets are glitchy, digital and harsh to my ears. However, with a bit of experimentation it's possible to uncover some effects that are a bit more gentle and melodically engaging. The comb filter is useful for bringing in some tonal heft, as is the feedback delay, which can be configured in units of MIDI note pitch. My personal tastes aside, this is a device which guitarists will probably love. And, as with the Meld instrument, the built-in modulation matrix is a significant asset. It sports two LFOs, a noise modulation source (with sample & hold, Brownian motion and others), and an envelope follower. Apply Roar's processing through »

### Meld Oscillator Types

1. Basic Shapes: Morph through classic synth waveforms, add overtones or change the pulse width.
2. Dual Basic Shapes: Morph through two classic synth waveforms and detune them against each other.
3. Noisy Shapes: Morph through classic synth waveforms and define the amount of noise injection.
4. Square Sync: Provides two sync'ed square waves where the frequency of each can be defined.
5. Square 5th: Morph a square to a square pitched a fifth above with pulse-width adjustment.
6. Sub: Provides a sub-oscillator with waveform morphing and an additional sub (aux).
7. Swarm Sine: A swarm of sine waves with modulation and frequency spacing.
8. Swarm Triangle: A swarm of triangle waves with modulation and frequency spacing.
9. Swarm Saw: A swarm of saw waves with modulation and frequency spacing.
10. Swarm Square: A swarm of square waves with modulation and frequency spacing.
11. Harmonic FM: A harmonic FM oscillator with modulation ratio and amount.
12. Fold FM: A harmonic FM oscillator with modulation amount waveshaping.
13. Squelch: An FM oscillator with modulation index amount and operator feedback.
14. Simple FM: A simple FM oscillator with modulation and index amount.
15. Chip: A chip oscillator which provides pitch, PW and interval.
16. Shepard's Pi: A Shepard oscillator with depth and direction.
17. Tarp: Impulse/drum oscillator with decay and tone controls.
18. Extratone: An oscillator that retriggers a kick drum oscillator at fast rates to produce granular-esque tonal sounds.
19. Filtered Noise: Noise generator with a resonant band-pass filter.
20. Noise Loop: An oscillator that loops a noise buffer at fast rates to produce granular-esque tonal sounds.
21. Bitgrunge: A pseudo-random lo-fi square wave oscillator reminiscent of loading an old computer game from a tape.
22. Crackle: A crackle generator with synthesized crackles.
23. Rain: A rain generator with synthesized drops and wind.
24. Bubble: A bubble generator with synthesized bubbles.

# The Silence Of The... Fans?

Embrace a peaceful start to the New Year with a fan-less system



 **PayPal**  
**CREDIT**

0% interest  
free finance up  
to 48 months\*

## 3XS Silent Audio Workstation

- Passive air cooling
- Ryzen 9 7900 12C/24T CPU
- 32GB Corsair 5600MHz DDR5 RAM
- ASUS TUF GAMING X670E-PLUS WIFI
- 500GB Seagate FireCuda 530 M.2 NVMe OS Drive
- 1TB WD Blue SN570 M2 NVMe Storage Drive
- Microsoft Windows 11 Home 64bit
- 3 Year Premium Warranty

 Windows 11

\*Choose PayPal Credit at checkout. Minimum spend applies. Terms and conditions apply. Promotion ends 31/01/2024.

Complete your ideal studio with a 3XS system solution

 [scan.co.uk/proaudio](https://scan.co.uk/proaudio) • 01204 47 47 47

**SCAN** 



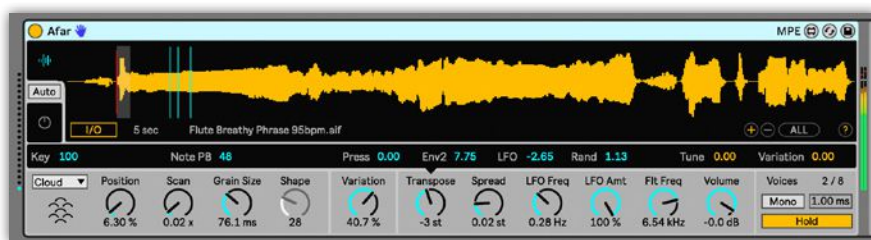

Robert Henke's Granulator III.

» modulation rather than just turning up the knobs, and it's possible to get some subtle and engaging effects, especially with rhythmic material.

### Granulator III

Live 12 Suite comes with the third generation of Robert Henke's granular sample player, Granulator III. The premise is largely unchanged from previous versions, but with quite a few refinements. I fired up Granulator II for comparison, and noticed some things that had been lost: version 2 had an FM processing section, dual filters and EQ, where version 3 loses the FM and has a single filter, albeit with more filter modes. Henke tells me that having a single, more powerful filter makes modulation easier (the modulation system is much enhanced over the previous version), while FM was not heavily used.

FM and filters aside, Granulator III is seriously enhanced compared to its predecessor. It also looks and feels convincingly like a native Live instrument, with a neater, much improved user interface. The top half of the display shows either a waveform with the granular 'play heads', or parameter editing controls, depending on which part of the voicing system is being edited. This view is selected as a side-effect of clicking on a knob at the bottom of the panel: the sample or control view appears as appropriate (although either view can be locked), and a thin black strip of numerical values across the middle updates dynamically to allow modulation of the highlighted parameter. It's not quite a modulation matrix, but is very neat and usable. (At some stage it would be great if Max For Live were to support full modulation matrix interfaces — perhaps we'll see that in time for Granulator IV?)

Granulator III is MPE-compatible, handy if you want to add per-note expression or modulation to your granular voices, and it also means that it can participate in Live's alternate tunings.

You can drag and drop audio files into Granulator's waveform panel to replace the audio source, and the instrument is also capable of live sampling up to eight seconds of audio from another source such as a track or external input (or, more accurately, it can retain the previous few seconds of audio instantaneously). I discovered that you can even attach an LFO to the 'capture' button to periodically replace the buffer while it's active, great for those experimental noise gigs. Captured audio can be saved as a file in the project to be reloaded later.

### Analog & Friends

Meld, Roar and Granulator III require a Live Suite licence, but if your budget only stretches to the Live Standard edition, there are still some goodies which come with Live 12: Analog (virtual analogue synthesizer), Collision (simulated mallet percussion), Electric (electric piano), Tension (string instrument emulator) and Corpus (resonant object modelling effect) arrived with Ableton Live Suite 7 a good 15 years ago (*SOS* February 2008), but will now be part of Live Standard.

### MIDI Tools

Live already has a toolbox of MIDI processing devices which, generally speaking, take in notes in real time and put out processed notes in response. These MIDI Effects are, in a sense, transient: they transmit their output but don't save it, and any MIDI clips that

feed them are unchanged whether MIDI Effects are running or not. The source clips and the final emerging MIDI are decoupled: the clip can be edited whilst effects are running, and a MIDI Effect can be reprogrammed — or even automated — while a clip is looping. The similarity to audio effects is obvious: the effect does not alter the original source or recording, and can be modified at any time. The humble Arpeggiator is a stereotypical MIDI Effect: it's generally fed long chords and outputs a faster repeated ostinato of notes.

So far, so familiar. Live 12 brings some new MIDI processing to the table in the shape of MIDI Tools, but these work in a completely different way to MIDI Effects. The tools operate at the clip level (Session or Arrangement), destructively altering notes in the clip. There is no live processing of notes: MIDI Tools alter the pitch, placement and duration of notes in-place in the clip, as part of the editing process (and there's no automation control available).

The tools exist in two varieties: generators and transformers. The generators create notes directly inside a clip, whereas transformers alter notes that are there already. Both types of tool operate on a set of notes that are currently selected for editing in the clip: a transformer alters the selected notes, while a generator creates notes when first invoked and then alters them on subsequent invocations. By 'invoke' I mean a click on an 'apply' button that does a one-shot application of the generator or transformer. The result is a new set of selected notes, but the tool can still be edited and reapplied if the effect is not quite as desired, resulting in a new, selected, note set.

An example might clarify things. The Arpeggiator (a transformer) will replace all selected notes with shorter,



Roar, in all its graphical glory.

arpeggiated notes — and these will still be selected and active. Changing the arpeggiator settings will alter these notes, moving them, adding new ones or taking notes away, but keeping them all selected. Click elsewhere in the clip area to deselect the notes, and the spell is broken: you've effectively frozen the notes into the clip, as if you'd put them there manually (or recorded the output of a 'real' arpeggiator). Once notes are deselected, there's no going back, except via global undo. Certainly, undo is your friend here when doing anything with the MIDI Tools — you'll use it a lot — but do something like alter the settings in an instrument and you'll clock up further undo steps, so you won't be able to undo just the MIDI Tool actions.

There are clearly some subtleties to MIDI Tools, and the drawback that a tool isn't 'live': once it's been applied and the resulting notes deselected, you're committed. On the other hand, you can then go on to edit the notes by hand,

or for that matter apply other tools. And, creatively speaking, committing to a course of action is often a good thing.

At the time of writing, there's a small set of bundled generators and transformers. In the generator category there's Rhythm (generate grid-quantised notes of a single pitch — best applied multiple times, one per drum part), Seed (a more general note-maker with variable pitch, duration and velocity), Shape (turns a user-drawn graph into pitches), Stacks (a chord sequence generator) and Euclidian (as the name suggests, a generator of four-voice Euclidian step sequences).

The transformers comprise the aforementioned Arpeggiator, Connect (connects equally pitched notes up in time, adding ties to taste), Ornament (adds flams and grace notes), Quantize (a note quantiser), Recombine (permutes notes in time), Span (alters note durations and spans notes to those following), Strum (guitar strumming), Time Warp (applies speed/tempo curves) and

Velocity Shaper (applies an arbitrary graph shape to note velocities over time).

Euclidian and Velocity Shaper are actually implemented in Max For Live, rather than coded internally in Live like the others, and you can actually build your own MIDI Tools from scratch. The Max For Live devices are pretty much indistinguishable from the native ones, but you need to have an active Max For Live licence to access them, and they are not quite as aware of Live's new scale mode as the others.

## Conclusions

Live 12 is a solid upgrade, and to me the overriding impression is one of refinement: interface improvements (particularly the browser), alternate tunings, powerful MIDI creation tools and a few tasty new devices — not to mention the arrival of a collection of previously Suite-only devices into the Standard edition. There's also an impression that Max For Live is getting some love, as devices like Granulator III look and feel polished and 'Live-native', and Max For Live can now do proper modulation. The only obvious shortcoming is lack of scale and direct tuning support in Max For Live, but I'm sure that will follow. All in all, recommended, perhaps as a late Christmas or New Year present for your studio. **////**

£ Live 12 Intro £69, Live 12 Standard £259, Live Suite 12 £539. Upgrade pricing available. Prices include VAT.

W [www.ableton.com](http://www.ableton.com)

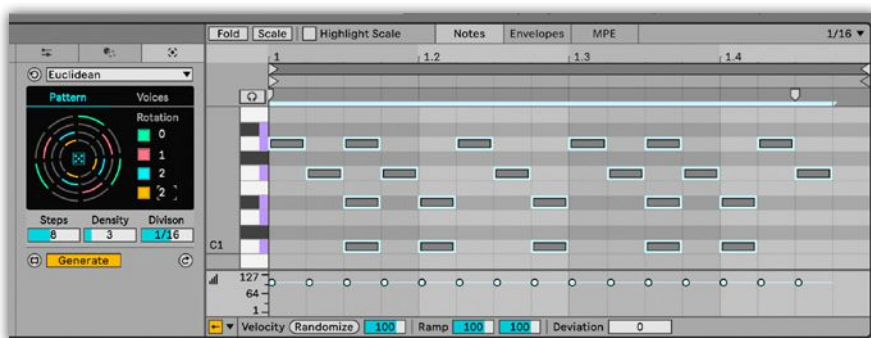

■ The Euclidian MIDI Tool.

## LAKE PEOPLE MC 100 MONITOR CONTROLLER

- Monitor controller for professional use with extensive features
- High-Quality volume control with 50 mm knob
- For controlling 3 monitor pairs plus subwoofer
- SB input with high-Quality D/A converter

MADE IN GERMANY  
Lake-People.de



LAKE PEOPLE  
TOOLS - NOT TOYS



# On Specs

## Part 2: Noise

Noise performance is important, but to fairly compare different products, you need to understand how noise specs are calculated.

JOSHUA ISRAELSOHN

Two primary signal-processing phenomena lead to audio-signal degradation: distortion, which will be the subject of Part 3 of this series, and noise, the subject of this instalment. Noise and distortion figures provided in manufacturer's spec tables, therefore, are key quantities when comparing the performance of two competing audio signal-processing products.

We can differentiate and define the two phenomena for the purposes of this treatment. Noise is any signal added to and independent of the intended audio by elements of the signal path. As such, noise is the signal present in the absence of an audio source, as is the case with a terminated or shorted input. Distortion, by contrast, is any signal component added by elements of the signal path in response to the intended audio. In the absence of an audio input, distortion is zero. In any but minute amounts, both phenomena reduce the clarity, presence and realism of audio presented to a listener.

In sufficient quantities, both can impact intelligibility, so they are important quantities not only in audio production and high-quality reproduction environments but even in what we might think of as lo-fi applications like,

for example, transit-system PAs, or mobile communication systems used by emergency first responders and commercial fleets.

### Noise As A Limit

At minimum, noise performance limits a system's dynamic range — the range from the smallest to largest audio-signal amplitude a system can represent. In particular, noise sets the lower limit of the dynamic range, establishing what engineers refer to as the noise floor. As well as reducing the intelligibility of speech — particularly soft or similar-sounding phonemes — noise can mask the performance nuances of acoustic musical instruments. In recording and post-production environments, dynamics processors can exacerbate the effects of noise allowed in at early stages of the signal chain, no matter if dynamics are managed in the analogue or digital domain.

Once added to a signal, noise is indistinguishable from intended audio by real-time signal processors. So, for example, gain stages amplify input noise as much as input signal. For this reason, the noise spec on signal-processing blocks that provide large amounts of gain, such as a mic preamp or instrument channel, may be more concerning than on a signal processor that typically

provides either unity gain or only several dB of 'make-up gain' as with, for example, an analogue equaliser.

Audio-equipment manufacturers typically specify the noise performance of their products in one or more of three ways: as an absolute Noise amplitude, as an SNR (signal-to-noise ratio), or as a Dynamic Range. The absolute noise amplitude is the most basic of these and is, in fact, necessary for manufacturers to measure and used to calculate the other two.

### Don't Panic

Though the broad subject of noise is sufficiently complex to engender textbook-length deep dives, for the purpose of understanding audio-equipment spec sheets, we need only scratch the surface of a few concepts.

Among them is the fact that the dominant noise sources in modern audio equipment tend to share a common spectral shape — that is the curve revealed by the way their energy distributes across a frequency range or spectrum. In audio gear, dominant noise sources tend to distribute their energy evenly across the audio-frequency range. Referred to colloquially as white noise (being analogous to white light, which similarly distributes

»



# The Revolution Expands.

Years of performing boutique upgrade modifications to audio hardware taught us how to build our own high-quality interfaces from the ground up. Boutique component choices, stellar clocking, and the best headphone amps in the game are just the start of the Revolution offering. Now, the legacy of the Revolution 2x2 has grown... introducing the Revolution 6x6 and the Revolution EXP.



## Revolution EXP

Expand your existing ADAT-compatible interface by adding 16 analog TRS connections and 16 channels of ADAT I/O. The possibilities are endless! Add hardware compressors, stereo reverbs, or other external hardware to your DAW workflow; record multi-channel

drums; or connect a multi-speaker array to build a Dolby Atmos monitoring rig. Revolution EXP boasts the same Macro-MMC clocking tech from our standalone clocks and interface mods; use it as the primary clock for your entire rig; everything you connect to it will sound better.

## Revolution 6x6

Beyond what you expect from an audio interface, the Revolution 6x6 is also a standalone DAC/ADC and primary word clock. Use the USB OTG connection to sample audio from your mobile device... or send audio from your laptop to your mobile device and stream your performances live online. All while treating your music with the highest audio quality imaginable. Sync your guitar modeler over S/PDIF for superior conversion and tone.

Join the Revolution at [www.blacklionaudio.com](http://www.blacklionaudio.com).

SOUND  
BETTER  
BETTER  
SOUND



» its energy evenly across the visual spectrum), these sources give rise to a mostly benign-looking expression of noise-power density in units of (fractional) W/Hz RMS. Here, the Hz refers to the measurement bandwidth. The wider the bandwidth, the more noise is detectable by the measurement.

As we saw in Part 1 of this series, terms and conditions apply and, here, a key condition is the measurement bandwidth, which spec sheets should identify. When considering competing products, check that the noise-measurement bandwidths match to make direct comparisons possible. Often, you'll find that the measurement bandwidth is 20Hz to 20kHz or 20Hz to 22kHz. Tests made with unmatched measurement bandwidths are not directly comparable, though one can



### Microphones: A Special Case

As explained in the main text, Signal To Noise Ratio and Dynamic Range are synonymous for most analogue devices. Microphones, however, are an exception. The Dynamic Range of a microphone is defined as the ratio between the loudest and quietest acoustic signals to which the microphone responds in a linear fashion — respectively, the noise floor and the point where it begins to overload. Signal To Noise Ratio for microphones is defined as the difference between the noise floor and a reference acoustic level of 94dB SPL. Since most studio microphones are specified to handle at least 120dB SPL without overloading, this means that specified microphone SNR is typically much lower than microphone Dynamic Range.

calculate estimates with a certain amount of mathematical machination in the case where we assume the dominant sources in both products are white noise. (It's also important to check that both measurements are taken using the same weighting scheme, a complication to which we'll return in a couple of months.)

A slight complication arises, however, when we note that we rarely measure or consider signal power. In most audio work, signals manifest as voltage amplitudes or their digital representations. We want to express noise, either directly or in comparison, in terms compatible with how we describe signals because the signal domain sets the context for our evaluations.

Signal power is proportional to signal voltage squared. To normalise measures to signal voltage, we take the square root of the power spectral density, expressing the noise voltage density in units of (fractional) V/√Hz RMS. Don't let the square root scare you off. It's just keeping the dimensions straight as we move from describing signals in the power domain to the voltage domain. You'll likely never have reason to calculate the square root of the noise-measurement bandwidth as a purchaser and user of audio gear.

### Rings A Decibel

Now that we're in the voltage domain for both signal and noise, we need only adjust our scale, because we don't use voltmeters to measure signals in audio production or post-production environments; we use meters calibrated in dB.

Though a measure in dB always suggests a ratiometric quantity, equipment makers can stipulate a reference amplitude and calculate the noise relative to that. So, in many spec sheets, you'll see noise expressed in dBV (dB relative to 1V) or dBu (dB relative to 0.775V — a historically meaningful reference potential that shows up often). Recall that 20dB corresponds to an amplitude ratio of 10:1. So, for example, a noise spec of -80 (= -4 x 20) dBu corresponds to a noise amplitude of 10<sup>-4</sup> x 0.775V = 77.5µV. If you're uncomfortable with maths, don't worry: there won't be a test and you'll not need to convert between voltages and dB. Equipment makers will do that for you.

One common approach to noise specs that manufacturers use is to express their product's noise

performance, not in absolute terms as we've done thus far, but relative to the product's maximum signal amplitude. Let's take the noise spec we just looked at and apply it to a product the maximum signal amplitude for which is +24dBu (12.28V RMS). The resultant Signal To Noise Ratio or SNR would be calculated by subtracting the -80dBu noise figure from the +24dBu maximum signal amplitude, giving a figure of 104dB. Note that, by using the dB's logarithmic scale, we accomplish the calculation of a ratio, which implies arithmetic division, with simple subtraction. Note, too, that the SNR expression does not include the reference voltage, because that quantity cancels when taking the ratio.

The remaining expression of noise performance in common use on audio-equipment spec sheets, Dynamic Range, is only slightly more conceptually complicated than SNR. In analogue equipment, the terms are essentially synonymous. Many digital and mixed-signal equipment designs, however, mute their outputs in the absence of an input signal, which would result in a noise measurement that fails to reflect the equipment's performance in normal use.

To make realistic noise measurements in such cases, test systems first establish the maximum input signal as they would for a standard SNR measurement but, instead of setting the test input to zero, the input is set 60dB lower than that for full scale. The measurement system must then apply a sharp notch filter to the output to eliminate all traces of the stimulus signal and measure the remaining noise.

Keep in mind, when comparing noise specs between competing gear, to make your evaluations in the context of your audio application. Applications such as recording spoken word, be it for a podcast or audio for video, acoustic instruments either in-studio or live, or room mics in a concert hall for ambience and audience response are all likely going to demand greater amplification and, thus, depend on good noise performance in the first gain stages than, say, channels processing mics over hard-hit drums or taking large output signals provided by electronic instruments.

*This series is produced in association with Audio Precision, Inc. ■■■*



# The 2448 Console.



To get a personalized online demo of the 2448, 1608-II or THE BOX Console  
schedule your **Virtual Console Experience** at  
[apiaudio.com/DEMO](http://apiaudio.com/DEMO)





# Best Service

## The Score By Sonuscore

### Sample Library

The Score offers a one stop, all-you-can-eat scoring buffet for composers in a hurry.

JOHN WALDEN

If your musical interests include music-to-picture composition, Sonuscore will be a familiar name. With both a range of their own virtual instruments, and a multitude of instruments developed in collaboration with the likes of Native Instruments, Steinberg and EastWest, Sonuscore's product résumé is very impressive. The latest addition to that catalogue, released in partnership with Best Service, is simply titled The Score. So, when it comes to scoring your next film, TV, advert or video game cue, what's the score with The Score?

### Theory Of Evolution

In essence, The Score represents a substantive evolution of Sonuscore's popular The Orchestra instrument, but with a nod in the direction of ElySION in that the sound set reaches out beyond just conventional orchestral sounds. Like these earlier products, The Score can be instantly gratifying, as a few simple chords can conjure a mightily impressive multi-instrument arrangement. However, under the hood it can also provide the user with a very deep and powerful compositional toolkit. If I attempt to cover all of the depth The Score offers, this issue of SOS might burst. What follows, therefore, is a swift overview alongside a deeper dive into one or two of the more important elements of the feature set.

### Feature Presentation

In terms of that overview, The Score includes a 20GB sample-based sound library that offers 160 individual sounds. These are organised into five categories: Orchestral, Synth, Band,



World and Misc. The user can access these through three different Kontakt front ends.

The first of these provides simple playable single articulations with the option to add effects and, while 20GB could perhaps be considered 'compact' in modern sample library terms, The Score's instruments really do sound very good. In part, this might be down to some sensible design decisions. For example, with the section-based orchestral instruments, you get ensemble-style instruments such as 'low string sustains' and 'high string sustains' rather than individual bass, cello, viola and violin options. The same 'low' and 'high' approach is used for the other instrument groups.

The second is the Ensemble engine. This is similar in concept to The Orchestra, but the ensemble now offers 10 individual instruments — each with their own sequencer options — rather than five. This engine is supplied with 120 style-based 'Stories' (presets) and, whether it's mystical and magical, ominous and tense, or joyous and magnificent (and plenty of other moods/emotions as well),

there is something to suit. Within each preset, keyswitches provide real-time switching between five different sequencer variations. These are consistently organised to provide an intro, two main performances (with increasing intensity), an outro and a single note/chord ending. Stories are also fully editable by the user (you can change all the sequencer contents) and you can create your own Stories from scratch.

The third engine — Melody — allows you to load either one or two of the individual instruments and then provides a toolset to generate melodic ideas. As we will see below, the Ensemble and Melody engines can share chord sequences, making it easy for the generated melodic lines to sit perfectly with the ensemble performance. As it's these Ensemble and Melody engines that are the highlights of the creative process, I'll focus on these below.

Both of these engines also offer full MIDI export capability so the performances you generate can be moved to multiple MIDI tracks within your DAW for further

editing and/or triggering alternative virtual instruments should you wish. In use, The Score's RAM demands are modest, with even the Ensemble engine presets generally coming in under 300MB. However, with 10 instruments plus effects in full flow, users of older host computers might need to keep an eye on the overall CPU demands, especially when running multiple instances.

## All Together Now

The UI for the Ensemble engine is split into three tabbed views: Find, Shape and Play. Find provides a neat browser with genre, style and time-signature tagging for both preset and user Stories.

With a preset loaded, The Shape page shows five of the instrument slots at one time (you can switch between instruments 1-5 and 6-10) with typical mixer functions including volume, pan, solo, mute, and a reverb send. Clicking on a channel header opens a dedicated instrument browser, while the channel FX buttons open a panel for adjusting EQ, attack and release, and three instrument-specific effects slots that offer a selection of common effect types. You can also access the Global FX options on the right of the UI. These offers a compressor, reverb (with convolution options) and an LFO. When engaged, the various 'chain link' icons within the display let you choose between the mod wheel or this LFO for individual parameter modulation.

From a performance dynamics perspective, the key control elements are the left and right 'handles' found within each fader strip. These define the minimum and maximum volume range of each individual instrument in

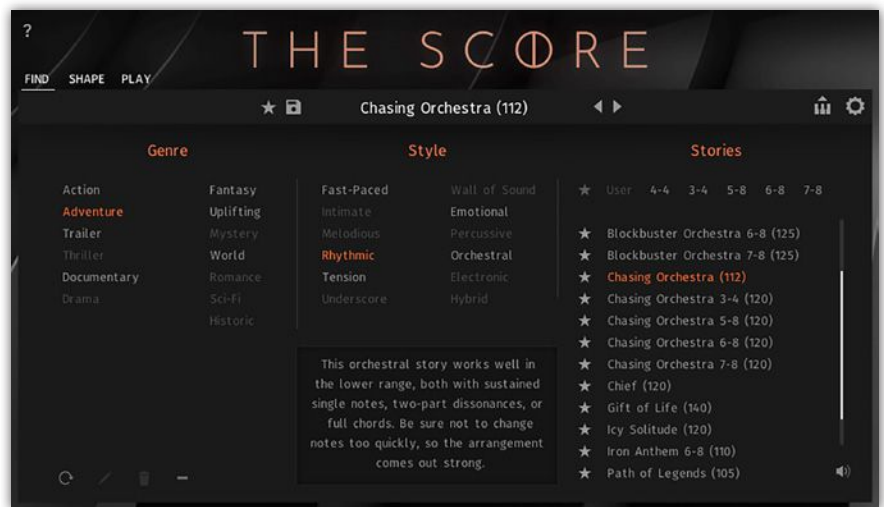

— The Stories presets for the Ensemble engine span a whole range of musical styles and are fully customisable.

response to the mod wheel, allowing you to easily modulate the dynamics of the whole performance. You can also invert the positions of the handles if you want specific instruments to get quieter as the mod wheel position is increased. As a visual reference, the current mod wheel position is displayed on the far left alongside the currently selected keyswitch (the five performance variations are triggered via C1 to G1).

The actual performance details for each instrument — including the different settings used for each of the five keyswitches — are configured within the Play tab. As shown in the screenshot, sustained instruments have an envelope-style sequencer, while non-sustained sounds use an arpeggiator-meets-step-sequencer approach. Again, this sequencer overview is split into two lots of five instruments. At the base of the page are global choices

can add two levels of accent to individual steps and the chain link icons shown here can be used to force non-sustained instruments to follow these accents on playback, providing a cohesive rhythmic sense to the whole arrangement. Accents can be configured differently within each of the five keyswitch patterns.

Double-clicking on one of the instrument headers on the left side of the display opens a detailed editing view for that sequencer. There are a whole host of options here including setting the step duration for non-sustained sounds (from quarter notes to 32nd notes and some triplet options). In all cases, you can define the upper and lower mod wheel dynamics on a per-step basis. For non-sustained sounds, various standard



(they apply to all keyswitches) over the sequence length (one, two or four bars) and time signature (4/4, 3/4, 5/8, 6/8 and 7/8) with normal time, half-time and double-time switches also available. At the top of the UI, you

Each of the 10 instruments within an ensemble features its own sequencer engine.

## Best Service

The Score By Sonuscore

€399

### PROS

- The Stories concept and Ensemble performance engine can provide instant musical inspiration from just a few chords.
- Plenty of user control for those prepared to fully exploit all the elements of the feature set.

### CONS

- Price may put it beyond some, although it does offer good value.

### SUMMARY

Sonuscore have taken the concept underlying The Orchestra and improved it in almost every aspect. The Score provides an instantly inspiring toolset for creating musical cues but still offers the composer plenty of creative input and control via a feature-rich UI.





— The sequencing engine provides plenty of options for customising the playback for each instrument.

» arpeggiator patterns are available, you can choose for an individual sound to only respond to certain notes within the incoming MIDI chord (for example, top note, middle two notes, bottom note, among a list of other possibilities), or you can choose a Custom option, which activates the lower 'dot' display offering full note triggering customisation — including multiple notes or no notes — for each individual step.

Amongst a number of other features contained within the Play page is the Chord Studio button. Once opened, you essentially get a playground to audition individual chords or chord sequences for use with the current Story. For chord sequences (up to eight bars in length), you can also add a dynamics (mod wheel) curve and set chord inversions. Each of the Stories includes an example chord sequence to start the ball rolling.

The Play page also provides access to two forms of MIDI export. First, you can drag and drop from the mini keyboard icon (located top right) into your DAW. This creates 10 individual MIDI clips, the contents of which reflect the full MIDI note output from each sequencer engine during the last performance pass (triggered live or via a pre-recorded MIDI clip). Obviously, once exported, they can be edited and/or used to trigger any virtual instrument. Second, if you create a chord sequence within the Chord Studio, you can do two things with it; either copy it into an instance of the Melody engine (more on this in a minute) or drag and drop the full chord sequence to a single MIDI track from where it can trigger the full ensemble and be edited further.

### Take The Lead

Many of the Stories include melodic-style parts but The Score's Melody engine

provides options for generating a more obvious melodic topline. Presets for this engine feature either solo or pairs of individual instruments with options to create your own pairs via the engine's Sound tab. However, with instruments selected, the real fun is to be found on the Melody tab. This features a Chord Studio-style chord sequencer that includes the option to import a sequence (via the receive button located bottom right) that you have already created within the Chord Studio.

With a chord sequence configured, clicking the Generate button will create a melodic phrase that works over the whole eight-bar chord sequence. You can repeat this process as many times as you like until something inspires, and you can audition the results directly within the window with simple block piano chords provided for musical context. You can switch the melody creation algorithm between four different modes (Easy, Complex, Slow and Triplets), and define the note range to be used. However, clicking

on the 'three dots' icon located top right opens a panel where you can customise a whole range of other parameters that will influence the melody generation process.

For each two-bar chord block, the A-D buttons allow you to create four alternate versions, and you can switch between these to refine the phrase or to create variations. In addition, double-clicking on the chord sequence opens a full MIDI editing environment if you want to manually tweak the generated melody. As in the Chord Studio, you can add a dynamics envelope. And, of course, MIDI export lets you drag and drop the melody into your DAW for further editing and playback. This engine provides a clever dollop of assisted musical inspiration while still giving you complete control over the final results.

### Keeping Score?

The more I used the The Score, the bigger my smile became. Working your way through some of the preset Stories is instantly gratifying; you just voice a few chords (simple or complex; the engine copes fine), modulate the dynamics with the mod wheel, and switch between the five performance variations with the keyswitches. If you were looking to generate a short (60-90 second) idea for a cue with intro, development and outro, it really can be mind-blowingly easy to realise a fully formed arrangement in real time. The Stories themselves span a huge range of musical styles but I have my fingers crossed that Sonuscore have a plan to keep delivering fresh Stories; whether free or paid, I'm sure users would find great value in that.

Sonically, the overall ensemble results are very impressive for both

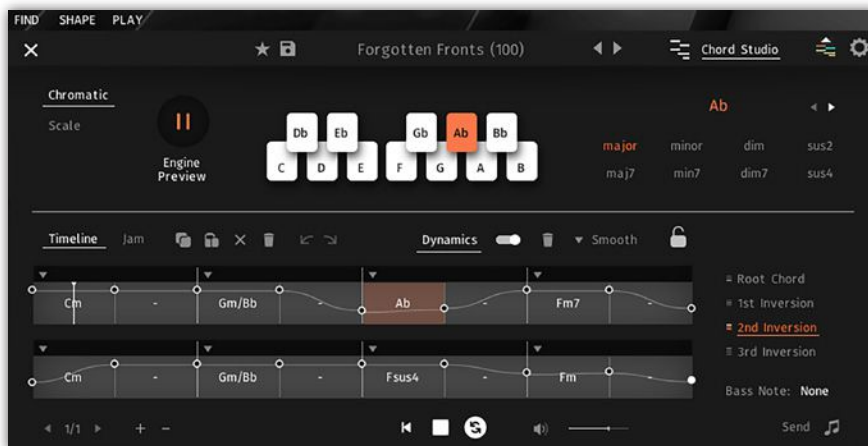

— The Ensemble engine's Chord Studio lets you experiment with chord sequences while you refine the performance.

pure orchestral and more hybrid scoring duties. The orchestral sounds are somewhat less raw than those in The Orchestra but, as a consequence, perhaps capable of being used in a wider range of contexts. If your project is unlikely to have a budget for a real orchestral recording, The Score would let you produce an end product that could be suitable for many broadcast contexts. And, of course, MIDI export lets you use your The Score creations with other sample-based sounds should you wish/need to.

However, there is more to The Score than the instant gratification provided by the preset Stories. Under the hood, the user gets a tremendous amount of control to customise how the performance engine does its magic, and what's really impressive is just how accessible that control is. The key here is the UI; The Score provides a very refined workflow experience. Users that spend a little time getting familiar with the full feature set will undoubtedly reap the benefits. This is powerful stuff.

Comparing The Score to other products, the most obvious candidates are Sonuscore's own The Orchestra (still a great product but The Score undoubtedly improves upon the concept) and EastWest's Orchestrator.

The latter is part of both the Hollywood Orchestra Opus Edition and Fantasy Orchestra. Both, at full price, are more expensive than The Score (although they are also available through the very affordable subscription-based Composer Cloud+ option), but also provide a much more comprehensive orchestral library. However, as EastWest partnered with Sonuscore to develop the Orchestrator, the conceptual similarities between these two 'performance' engines is hardly surprising.

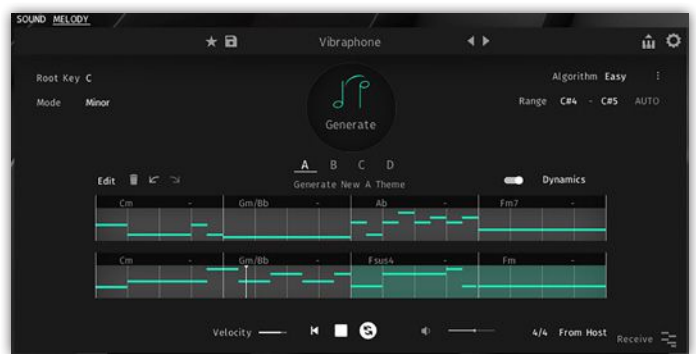

— The Melody engine provides a flexible toolset for generating melodic ideas suitable for use with a chord sequence imported from the Chord Studio.

Yes, Sonuscore's latest offering will be beyond a casual purchase for many potential users, but for those prepared to fully embrace all the flexibility provided by the feature set, it packs a considerable punch for its price. With an impressive ensemble sound and a slick workflow, this is a hugely inspiring platform for composition; The Score scores on many levels. **///**

£ €399 including VAT.  
**W** [www.bestservic.com](http://www.bestservic.com)

# The SlatFusor SERIES

## Modern Elegance

Superior Acoustic Panels & Bass Traps



**GIK ACOUSTICS**  
 SOLUTIONS. INNOVATIONS. QUALITY.





# Win!

# Antelope Audio

# Atlas i8

## Active Monitors

Worth £4290

Antelope Audio are renowned for making some of the finest audio interfaces and clocking systems in the world, and have recently branched out into the world of studio monitoring.

As you'd expect from Antelope, their debut Atlas i8 monitors are packed with technological innovation. Internally, they make use of the company's established DSP expertise to ensure perfect time- and phase-alignment of the drivers, as well as offering comprehensive EQ options.

The drivers themselves also represent some serious electro-acoustic engineering. The tweeter and midrange drivers, for example, are arranged coaxially, delivering point-source

precision and optimum dispersion, and also allowing the Atlas i8s to be mounted either horizontally or vertically, depending on your studio's needs.

But perhaps the most distinctive thing about the Atlas i8 is its use of dual bass drivers. There's one on the front baffle,

To enter, please visit:  
<https://sosm.ag/antelope-comp-0224>

as you'd expect, but immediately behind it is a second, identical driver — a loading technique known as 'isobaric'. The two drivers are wired in series and operate in their own sealed sub-enclosure, which has the effect of increasing the driver

suspension stiffness and extending the speaker's low-frequency response.

All of which adds up to an extremely good monitor. When we reviewed the Atlas i8 back in December, we were hugely impressed by its extended bass, low distortion and focused stereo imaging.

And for this month's exclusive SOS competition, we've teamed up with Antelope to offer you the chance to win a pair of your very own!

To be in with a chance of winning these fantastic monitors, simply follow the URL shown, and answer the questions there, by Friday 1st March 2024. Good luck! **///**

Prizes kindly donated by Antelope Audio  
**W** [www.antelopeaudio.com](http://www.antelopeaudio.com)

**“As you'd expect from Antelope, their debut Atlas i8 monitors are packed with technological innovation.”**





# BLACK ARTS

Photos: Finn Håkon Rødland

## Producing Norwegian Black Metal, Part 1: Eirik 'Pytten' Hundvin & Mayhem

Mayhem's *De Mysteriis Dom Sathanas* is the cornerstone of Norwegian black metal. We talk to producer Eirik 'Pytten' Hundvin about his unique philosophy and the making of this genre-defining album.

JILLIAN DRACHMAN

**T** rue' Norwegian black metal is sometimes referred to as the nation's biggest export. For the uninitiated, black metal is not only an elitist art form, but a lifestyle. Despite its brutality, this extreme subgenre is culturally

sophisticated, and imbued with poetry, spirituality, philosophy and mythology.

Eirik 'Pytten' Hundvin is widely regarded as the most influential producer and engineer within the genre. Pytten has co-created revolutionary albums with many of the movement's greatest spearheads, such as the True Mayhem, Emperor,

Immortal, Enslaved and Gorgoroth. Many other groups, including the revered Tsjuder, take Pytten's canonical masterpieces into the studio as reference material.

Pytten himself is semi-retired and rarely collaborates with black metallers any more, though he still works with other forms of music. However, "as a side gig" he continues to assist the veteran black metal artists who form the band Deathcult. He's also an accomplished musician himself, who plays with Elektrisk Regn and the Rolling Clones.

Pytten received his initiation into the metal community in 1990, when a former classmate phoned him to ask if he would be willing to work with his son Tore Bratseth's band Old Funeral, a pioneering black/

death act whose line-up featured several future icons during their lifespan. The result was Old Funeral's groundbreaking second demo, *Abduction Of Limbs*. Not only was this Pytten's very first experience with extreme metal, but it was also the band's "first serious recording situation... I did bring them into the studio to set up for a session where we all could find out what to do and how to do it in the best way, so that the music and sound would come out better than the band expected. And very important, I had to carefully adjust my recording ways by trying, watching, and listening for their reactions.

"I kept my mouth shut and eyes and ears open. They were the experts on the music and the sound. I used my expertise in recording."

### Safe Spaces

Although Pytten's approach has changed a bit, he has remained careful not to hinder the creativity of emerging artists. His principal advice to bands going into the studio for the first time is to have their instruments in good shape: "Keep your tools sharp. No dirty strings. Keep your drums as good as you are able to. I hate toms that are more useful as buckets for carrying water."

Pytten's work with Old Funeral drew related outfit Amputation to work with him, and soon other trailblazing acts were flocking to Pytten's studio. "It struck me quite early that a lot of these people were not that much older than my own kids. So, it was easy to get along with them... No matter what they brought to me, I really respected what they were working on, what they were creating. In a way, they needed musical guidance. They needed the security of knowing they were accepted to work in the studio, because to be in the studio, and especially for the singer, is to be really exposed. It can make you bloody nervous.

"Singing in the studio is, in my opinion, a very private situation, maybe the most private. With this in mind, I always try to create a suitable and comfortable atmosphere for the singer. This goes for all styles of music. Not a cozy one, but safe, no hardship..." Pytten aims to promote "communication that is friendly but demanding when needed. I give people time to set their lair, whichever way they want it, literally creating their working environment."

Pytten emphasises that knowing when to stop doing takes is key "because you will sometimes have a low-low-low valley you have to get into. Then, maybe-maybe-maybe

you manage to get up again. So, I'm trying to find the right time to say: 'This is the moment!'"

### Space & Feeling

Needless to say, the harsh soundscape of extreme metal poses a special challenge from the engineering perspective. Pytten recalls that the chaos and intensity of the music made an immediate impression upon him. He quickly realised: "I have to make room in this production, so that when people listen to it, they will be able to hear what's going on." Pytten gently went about balancing and cleaning up "boomy and harsh" frequencies. Pytten stresses: "I'm really keen on searching for what's going on with the drums and putting it together with the guitars so they don't fight. Both guitars and cymbals have high frequencies and sustain, so one really has to consider what frequencies to enhance or lower. In black metal, there are some parts with so many attacks on guitars and cymbals... Too much of a similar frequency will sound harsh and might exhaust the listener. In the bottom area, one needs the same attitude not to camouflage what's going on. With an electric distorted guitar, at some point in the low mid/sub area, the frequencies will stop carrying what I consider musical information. Below this point, there will be an additional boomy sound. But is it needed in a recording? In the rehearsal room, that sound fills the room, and I love the physical thrust and the feeling you get. But one needs to be very careful about this while recording and mixing. You cannot bring that same feeling of physical volume through a recording/mixing process. In my opinion, you have to create the impression of this physical 'feeling'. In this context, I see the band's ability to present their musical content and level of energy as very important."

Along similar lines, Pytten advises: "Be really picky and conscious about the choice of added effects. A lot of times, people comment on something not being loud enough, and that might be so, but, very often, you can bring it out by making room and not necessarily raising the volume. I always try to have an opinion on what needs focus at any time throughout the song."

### Hallowed Halls

For a period of 24 years starting in the late '80s, Pytten famously operated in Grieghallen, a gorgeous concert hall named after the great Edvard Grieg. "If you don't have a great room, you can never do great recording," he insists. Pytten initially used a studio attached to the stage, before moving to the basement. Then he received a new space on the third floor, which he occupied until 2013. Since then, his presence is still felt in Grieghallen, and he has even given guided tours during the Beyond The Gates festival.

"Grieghallen was and still is the home of the Bergen Philharmonic Orchestra," he notes. "What a lucky coincidence! What could be more attractive than checking on the Bergen Philharmonic's basement percussion pool — timpani, huge bass drums, gongs of different sizes. The best dungeons ever for creative black metal souls like [*Enslaved's*] Ivar Bjørnson!"

Pytten has incorporated the Philharmonic's instruments into his black metal productions on various occasions. "On the very late evening of Monday, the 25th of July 1994, we went down there and borrowed two shining copper timpani. We wheeled them carefully to the studio and overdubbed them at the start of *Enslaved's* 'Loke' [*from Frost*]. One was tuned in G, the other was tuned in A. We recorded with

»

### Keep It Rough: Metal Pre-production

"I always search a lot for what people bring to me," says Eirik 'Pytten' Hundvin of his production philosophy. "I don't have any formulas. I listen and try to put things together the way I think is best for the production and the band. It doesn't matter what kind of music I'm working with."

Regardless of how brutal a group's core sound seems, Pytten's aim is to "pick it up, bring it out, and keep it as identical as possible. I will always check demos if available, but sometimes the attitude driving a demo is to show the best of the song and sound, and then production might be well on its way. This can end up in a competitive situation where the song's

potential, in my opinion, will not always be able to be reached. But, of course, this is a might, not always. I prefer rough demos done in simple recording situations from rehearsals. Even better is to be in the middle of the band and the sound they create in their rehearsal room. Very often, without even talking about it, they show their potential."

Pytten likes to observe bands in "their safe place" so that he "can get an idea of their songs and their energy". These days, Pytten prefers to record groups during this phase with his mobile phone, whereas he opted for cassette recorders in the past.





» a B&K 4011 through a Behringer compressor. Track 20 and 21. Just listen, it sounds impressive! Thank you, Bergen Philharmonic Orchestra.” (The internationally acclaimed Enslaved, by the way, have received more Spellemann Awards, or ‘Norwegian Grammys’, than any other group.)

### Making Mayhem

Mayhem’s 1994 album *De Mysteriis Dom. Sathanas* stands as one of Pytten’s greatest triumphs. This influential masterpiece is widely regarded as the definitive black metal album, and Pytten recalls the experience of collaborating with the band as highly fulfilling. He particularly enjoyed brainstorming with the band’s guitarist and co-founder Øystein Aarseth, aka Euronymous, as well as with Jan Axel ‘Hellhammer’ Blomberg, who is regarded by many as the genre’s top drummer.



“My ideas often come from interactions with other people,” says Pytten. I got to know Øystein while he was collaborating on recording Burzum’s first album. This was before we started working on any of Mayhem’s music. He was keen and competent around the studio. We were doing fine together. As soon as we agreed on doing the *De Mysteriis* album, he sent me demos of rehearsals. I remember being impressed by the quality of the songs and the competence of the band, particularly by Hellhammer being the nuclear powerhouse in the middle of the music. I decided at once to use a bigger room in Grieghallen. Luckily, we found a period where the main hall was available. Hellhammer was like a little boy in a toy shop the first time he saw the stage. He really wanted to do the drums there! Øystein also sent me a three-page letter going through a lot of aspects related to all songs and earlier experiences in studios either to avoid, improve or build on. I also spoke to both Øystein and Hellhammer on the phone.

“For guitars, I was confident with the small, very tight room used for comments on classical concerts by the [Norwegian Radio Orchestra] NRK. We discussed setups and how to do everything during the recordings. Even before they [Mayhem] were in the house, I was very optimistic about using the stage for recording the drums. All channel lists and outboard destinations were done well before they arrived.”

For the sessions, Pytten and Mayhem twisted the outstanding acoustics

■ One of the attractions of Grieghallen for metal bands is the resident selection of orchestral percussion, including this huge gong!

of Grieghallen to their advantage. Hellhammer’s drums were surrounded by a cage that closed off the sides of the room, but left the top open: “On the Grieghallen main stage, I made a square drum room with stage curtains, approximately five by five metres, and six or seven metres high. Hellhammer rigged his drums, and I put up the microphones. Mainly very straightforward, quite close drum mic setup, except for the overheads. I used two Schoeps MK6 microphones set to figure-8 above the centre of the drum kit. Parallel, vertical axis, 17cm apart. The stage height where I placed the drums was approximately like a nine-storey building, and to find the right placement, we did test recordings to find the preferred sound. They ended up approximately one to one and a half metres above the cymbals. The curtains stopped all slapbacks and delay from the huge room being recorded on the close-up microphones, while still having all this wonderful air from the overheads.

“As I remember, this was based mainly on my knowledge of the room and all agreeing on not using the small room. We wanted a huge sound. But very important as well, Hellhammer was (and is) a very competent drummer that knew and understood their music. He also kept his drums to the optimum sound-wise and was very conscious about how to get the drum setup exactly the way he wanted it.”



Pytten recalls that they “did initial recordings on 12 drum tracks, doing mixdowns and overdubs ending with eight or nine drum tracks. We had to do mixdowns of part of the drums. While doing that, Jan Axel dubbed the toms. So, we got this really fat and broad sound.” These overdubs were done in the mixing room, as opposed to on the stage. Fortunately, Hellhammer’s remarkable precision meant that his overdubs fit in seamlessly. “While doing the drum recordings, Øystein played a guitar track on all songs.”

### Fast & Tight

Pytten recalls accurately the equipment used to record Euronymous’ guitar parts: “One red sunburst Gibson Les Paul; one Marshall (I believe) [JCM]800 amp; one Marshall 4x12 cab; and I think one yellow Boss distortion pedal. One AKG C414 and one B&K 4011, quite close to the cab, in a very tight vocal overdub recording room. During two tracks, the 414 went left and the 4011 right. So, what came out of the cab is what you hear on the album. For at least one solo, we took the Marshall stack out in the audience part of the hall. The B&K 4011 was on a high stand during test recordings till we found the best sounding placement of the 4011, and then did the solo! What can I say, very well-prepared guys. Using time to find positions and sound. Then doing the music. Lovely!

“The bass was done in the control room. Very convenient, easy tech-wise — DI straight to the desk. All communication on

the bass line and bass sound was direct. Everybody was involved very closely. And like the drums and guitars, the bass was well prepared, but there was still room for creative adjustments.” Mayhem employed “one fretted [bass] and one Fender ’63 Precision made fretless.”

Pytten wasn’t sure what to expect from Hungarian vocalist Attila Csihar, and recalls feeling truly surprised when Attila delivered a performance unlike anything that anyone had heard before. Attila’s style on *De Mysteriis* can be compared to that of a demented priest, and has become iconic. “Attila wanted a smaller space in the recording room, so we set up in a corner, closing in a square workspace with stands and curtains. He has an expressive, physical way of singing, so I could not use any of my premium mics. I chose probably something like SM58, RE20, RE27. Maybe he even used his own mic for the recordings. I really don’t remember. Attila’s way of singing was indeed a different attitude than that of the standard black metal vocalist. As soon as we started listening to the playback of the first song, I felt confused, but, at the same time, I realised that this was a very expressive and dramatic way of voicing a black metal album. It never went to the hard scream, but it kept the spooky tension through all the songs. A piece of art!”

### At The Mix

According to Pytten, the limitations of working to tape meant that “a lot of the

■ Pytten at Bergen’s Grieghallen. For the recording of *De Mysteriis Dom. Sathanas*, Hellhammer’s drums were set up on the main stage, within an improvised booth made of heavy drapes.

work you do now while mixing you did then while recording. So, decisions. Decisions. Decisions. I like doing it that way.

“The way I saw the mix was to bring out all we had recorded. The basic sound and colours were already there. I had no automation, all was done in an analogue setting, except for some of my outboard: Lexicon 480, Eventide HS3000, etc. Atari and SMPTE track for samples. No total recall like today’s computerised systems, but that was OK. No hassle. That’s the way I worked. I don’t remember much in the way of details around the mix. It was Øystein, Hellhammer and me. Maybe some people dropped in to say hello and snuck in to listen. Not many. I always keep a quite private control room. I remember we had a nice and relaxed time doing the mix. Øystein and Hellhammer were never on my shoulders. We probably had discussions, but in a constructive manner.

“When people say something, I hardly ever say: ‘No.’ There’s one sentence that I use very much: ‘Oh why is that?’ And also, ‘Tell me about it. What do you mean?’ I use that all the time.”

In next month’s *SOS*, we talk to Kark and Necromorbus, two of today’s leading black metal producers who were inspired by Pytten’s work on *De Mysteriis Dom. Sathanas*. ■■■



# Kombo Audio Kombo

## Portable PA System

With battery operation and wireless connectivity built in, the Kombo could be the ultimate 'go anywhere' PA.

PHIL WARD

I wrote about the Yamaha StagePas 200 battery-powered portable PA/busking speaker back in *SOS* May 2023, and began my review with an assertion that there aren't many such backline products around. So I should have known that I'd almost immediately happen upon another one, the Kombo, which is the subject of this review.

The Kombo is the product of a Danish startup company called Kombo Audio, and while it is primarily aimed at the same kind of applications as the previously mentioned Yamaha product, it introduces a few unusual twists of its own — the main one being that it's specifically designed for wireless connection to its instrument and mic inputs. To enable this, the Kombo

### Kombo Audio Kombo

€1475

#### PROS

- Appealingly quirky.
- Versatile.
- Wireless tech works well.
- Great sound quality and build quality.
- Impressive battery life.

#### CONS

- There is no EQ or effects on the wired inputs.
- The flip side of the solid build quality is that it's a little heavy.

#### SUMMARY

It's no easy task to innovate in pro audio, but Kombo Audio have done just that with the Kombo. It's quirky and novel, yet does the important things really effectively.



ships with two wireless transmitter belt packs (one with an instrument input and one with a mic input), and two receiver modules. These attach to magnetic ports located either side of the rear of the Kombo cabinet itself, and electrically connect automatically. Extra transmitters and modules can be purchased to enable up to four wireless inputs to be used, and the Kombo also offers three conventional wired inputs (one mic, one instrument, one line) so, in theory, a seven-piece band could busk with a single Kombo. There's more: because the Kombo also provides a Bluetooth audio connection,

that seven-piece could also play with backing tracks streamed wirelessly from a smartphone.

#### The Box

The Kombo is usefully compact in dimensions and feels very solidly put together. All the enclosure edges and corners are coated in a matte-black rubberised bumper finish, and its front grille is black-painted, perforated steel. I can see the Kombo surviving with no trouble at all the rigours of a life of busking or in makeshift gig or rehearsal spaces. The slightly inset side, rear and



end panels of the enclosure are finished in a contrasting grey leather effect, and it all makes for a unique and quirky appearance. A generous carry handle is inset in each enclosure end panel and, while my review sample lacked this detail, future production will, I'm told, replace the bottom carry handle with a pole-mount hole.

One slight downside of the Kombo's impressive build quality is weight. At 13kg the Kombo is not an insignificant lift, and certainly not something you'd want to carry a long distance from the car park to the town-centre busking site. It is, however, perfectly proportioned to fit on a small sack-truck style trolley. And I guess I'd rather have a busking amp that's built to last than it be a few kilograms lighter.

One element of the Kombo that contributes to its weight is, of course, the battery. A lithium-ion device, this is supplied uninstalled and has to be inserted in a rear-panel recess where it connects to a multi-pin terminal block and is held in place by a Velcro strap. The Kombo can't be used without its battery installed. Battery charging is achieved through a mains power supply that connects to the Kombo rear panel using a 24V DC connector. Kombo Audio claim a 20-hour battery life, which ought to be adequate for even the most profitable of busking spots. The Kombo wireless receivers and transmitters are also powered by rechargeable batteries, and can be charged, two at a time with a supplied splitter cable, from the USB Type-A charger output on the Kombo rear panel. The receivers and transmitters are fitted with micro-USB charging inputs.

■ The Kombo ships with two wireless transmitter/receiver pairs: one designed for mics, with an XLR input, and one designed for instruments (pictured), with a high-impedance jack socket.



When I first came across the Kombo I imagined that Bluetooth might be employed for its wireless connection from transmitter to receiver. I was completely wrong because, in fact, Kombo Audio have developed a proprietary dual-band (5.2GHz and 5.8GHz), eight-channel wireless protocol for the Kombo that they say offers 30m maximum range and transmits uncompressed audio. The wireless protocol also, say Kombo Audio, results in just 7ms latency, although the Kombo's internal DSP potentially adds another 3ms, for a total of 10ms. It's perfectly workable latency for live performance. One useful possibility that the Kombo wireless protocol enables is the connection of individual transmitters to two receivers. This means that either stereo sound or simply extra volume can be had by adding a second amp/speaker unit.

Behind its front grille, the Kombo sports a single 200mm coaxial driver comprising a paper-diaphragm bass/mid element and a compression tweeter. The coaxial arrangement of the two elements helps ensure both phase alignment and consistent dispersion. The bass/midrange driver is reflex loaded in the enclosure by twin front-mounted ports. An Infineon Technologies Merus Class-D amplifier module provides 160 Watts for the bass/midrange driver and 40 Watts for the tweeter. Kombo Audio claim a 60Hz-20kHz ( $\pm 3$ dB) frequency response and a maximum continuous output level of 110dB SPL at 1m. These

aren't specs that are going to blow the roof off a stadium, but for the intended small-scale gig, rehearsal or busking application they're perfectly adequate.

### Wireless For Sound

The two transmitters and receiver packs supplied, and available as additional extras, with the Kombo are not the same. One, known as a KAM (Kombo Audio Microphone), provides a female XLR connector and a phantom power selector button on its transmitter body. The other, the KAS (Kombo Audio Strings), is intended for guitars and other instrument-level signals and provides a high-impedance jack input and a feedback suppression button (which simply flips the polarity) on its transmitter body. Both KAM and KAS transmitters also incorporate a belt clip, an on/off button, a wireless channel selector and a battery level indicator.

The KAM and KAS receiver elements are also different. The KAM receiver offers a range of adjustment parameters, selected sequentially by pressing left and right buttons. These are volume, FX1 (compression), FX2 (reverb), high EQ, mid EQ and low EQ. The KAS receiver offers the same set of named parameters, selected in the same way, but the behaviour of FX1 and FX2 is modified by an extra slide switch, with Acoustic, Guitar Amp and Bass Amp options. In Acoustic mode, FX1 offers Reverb and FX2 Tone Warmth; in Guitar Amp mode, FX1 offers Drive and FX2 offers Reverb; in Bass





» Amp mode, FX1 offers Drive and FX2 offers Compression.

In both the KAM and the KAS, the level of a selected parameter is adjusted by turning the outer rim of the receiver module. A circular array of LEDs illuminates sequentially to indicate the parameter level, and a group of parameter settings can be saved by pressing the right parameter button so that selection returns to the first parameter. I found the whole process a little counterintuitive at first, but once understanding and memory kicked in it became second nature.

### In Use

In terms of their subjective quality and character, the effects offered by Kombo fall, to my ears, into the 'uncomplicated but effective and instantly usable'

category. They're unlikely to win awards, and you probably won't be using the Kombo as a recording amp (never say never, though), but dialling in a touch of reverb on voice, a smattering of drive on guitar or a dose of compression on bass does exactly what's likely to be appropriate in the context. It's easily possible to get usable and satisfying sounds very quickly, and that's really the whole point.

Part of the satisfaction of the sounds available from the Kombo is a result of its fundamentally well-sorted electro-acoustics. Apart from a slight nasal tendency, which primarily results I think from an inherent upper-mid tonal emphasis, the Kombo displays a pleasingly natural character on voices and guitars, and plays a good level of high-frequency detail without

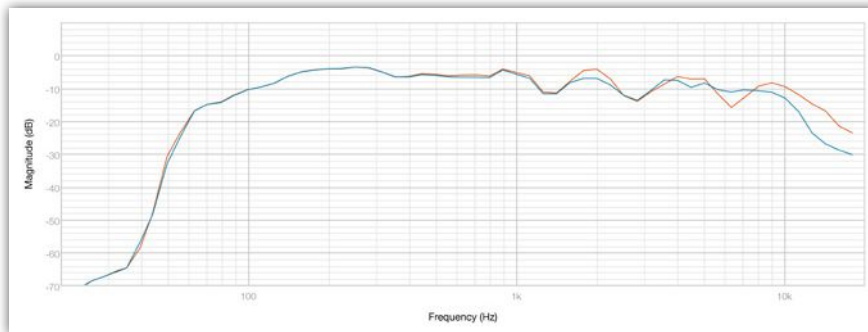

■ Diagram 1: The Kombo's frequency response, measured on- and off-axis (red and blue traces, respectively).

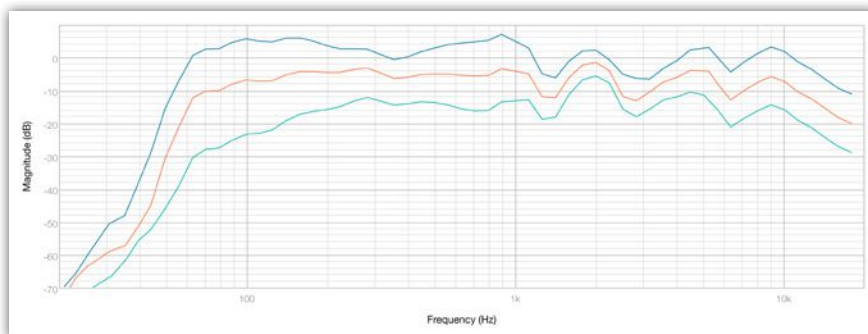

■ Diagram 2: The Kombo's EQ, set to flat (orange trace), and with all three bands at maximum cut (green) and boost (blue).

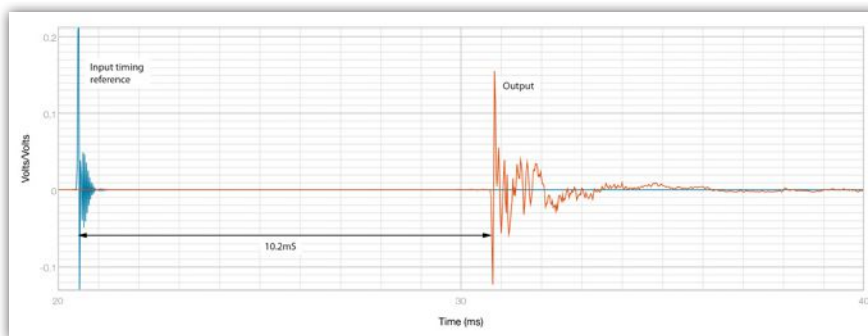

■ Diagram 3: A measurement of the Kombo's total in-to-out latency.

### ALTERNATIVES

While there's little competition for the Kombo if you're seduced by its wireless abilities, other battery-powered, one-box PA products that live in a similar performance bracket include the previously mentioned **Yamaha StagePas 200**, the **Roland Cube Street EX** and the **Electro-Voice Everse 8**.

much evidence of compression-driver harshness as it gets louder. The other side of the midband coin is, of course, that voices will cut through. Basic vocal intelligibility from the Kombo is very good. The Kombo does struggle a little with loud bass fundamentals, but that's to be expected considering its compact dimensions and relatively small bass driver, and anyway, impressing with epic bass is not really what the Kombo is about.

Apart from mentioning that they exist, I've not so far covered the Kombo's three wired inputs, but that's partly because there's not a great deal to say. The inputs comprise two unbalanced jacks and one balanced XLR socket, each with an associated gain knob, located on the rear panel. The wired inputs have no effects or EQ facilities, which perhaps is a shortcoming, especially for the mic input where you might want the wired vocal input to share the same reverb as the wireless mic input. The line and instrument inputs I could see being used with upstream effects, so perhaps the lack of anything integral to the Kombo is not that big a deal. While I'm on the subject of the rear panel, there's also a main volume control to be found there, along with a Bluetooth connection indicator and a 'Mute Everything!' panic button.

### Measuring Up

I fired-up FuzzMeasure to investigate a few of the acoustic characteristics of the Kombo. Without hiring a big empty space (or spending £100k on sophisticated analysis kit), it's not possible to accurately measure the anechoic frequency response of a full-range loudspeaker, but even doing some simple in-room measurements can reveal useful information. So, to that end, Diagram 1 shows the smoothed, close-mic axial frequency response of the Kombo with a 30-degree off-axis curve overlaid. The interesting thing about this is not the somewhat lumpy response curve (that's

partly the result of reflections in the room) but the relatively small difference between the on- and off-axis responses. This suggests that the Kombo has usefully wide dispersion, and considering its intended role, that's a good thing.

Diagram 2 shows the effects of the KAS ('string') transmitter/receiver EQ. The 'flat' curve is in red, with bass, mid and high at maximum and minimum in blue and green respectively. The curves reveal the expected results, although it's also interesting just how much gain the LF EQ applies at maximum boost (14dB at 60Hz), which can result in the Kombo audibly struggling somewhat with noticeable levels of distortion and port noise. I'd employ the LF EQ with restraint.

Finally, Diagram 3 illustrates a quick check of the total in/out latency through the KAM transmitter/receiver. The two events in the impulse response show a timing reference of the recording interface output (a Focusrite Dante interface sharing a network) at 20.5ms, and the Kombo output arriving just before 31ms. The 'flight time' of the acoustic



The microphone transmitters in action.

energy leaving the Kombo speaker and arriving at the microphone will also be embedded in the measured 10.2ms, so Kombo Audio's claim of 10ms latency seems justified.

I grew to admire and like the Kombo very much while it was in my possession. It's a smartly designed and engineered product that provides an effective and innovative solution to a fundamental need. I can't see many gigging, busking

or rehearsing musicians not taking to it straight away. It sounds good, plays suitably loud with great clarity, has great versatility, and the wireless features work well once you have your head around how they're set up and configured. It's a very impressive and engagingly quirky first product for Kombo Audio. **///**

£ €1474.80 including VAT.  
W [komboaudio.com](http://komboaudio.com)

nord®

nord stage 4

"The Nord Stage 4 is a huge step up from previous incarnations"

SOUND ON SOUND

Headline  
Audio

Exclusive representation & distribution in the UK & ROI by [headlineaudio.com](http://headlineaudio.com)



# Multi- miking







Using more than one mic on a source can expand your sonic horizons — but it can also lead to problems. We explain when multi-miking is and isn't a good idea.

MIKE SENIOR

It's easy to understand why multi-miking is such a hot topic amongst project-studio recordists. Not only can it offer enormous tone-sculpting power while retaining lots of mixdown flexibility, but it also provides a welcome justification for buying lots of shiny new microphones. However, this technique can also backfire easily, too, because using extra mics introduces more opportunities for mistakes and complications. Indeed, having mixed hundreds of project-studio multitracks myself (including plenty for *Sound On Sound's* own *Mix Rescue* column), I can attest that small-studio engineers frequently sabotage themselves with their multi-miking methods, slowing down the production process and compromising the quality of the final mixdown. So in this article, I'd like to suggest how to avoid some of the most common pitfalls, so you can get the best out of multi-miking.

### What Else Does The Sound Need?

In this article I'll be talking specifically about multi-miking for tone, as opposed to stereo miking (which necessarily uses multiple mics). And probably the most common misconception about this sort of multi-miking is that it's some kind of panacea for getting good recorded tones.

When you put up just one mic it's pretty obvious that you have to pay attention to how it sounds, but somehow the very presence of more than one mic seems to lull far too many people into a false sense of security, so that they switch off their ears under the assumption that they can leave the sonic decisions until mixdown.

But the reality is that there are many more bad microphone positions than good ones, especially when you're working with budget mics and in untreated acoustic environments. I'd estimate that roughly three quarters of the initial microphone choices and/or positions on any project-studio session usually need adjusting in some way if you're going to achieve genuinely workable recorded results, so having two or three mics on the go certainly doesn't guarantee that any of those mics will actually sound any good! For example, one of the most challenging *Mix Rescue* remixes I ever tackled featured a triple-miked acoustic guitar recording where all the mics sounded pretty awful, which made it a nightmare to salvage anything usable. And I've lost count of the number of drum kit recordings where I've immediately thrown away the additional 'subkick' mic (where you basically record the output of a speaker cone hanging in front of the kit) at mixdown because it offered nothing but completely inappropriate low-end flab.

»



However many mics you use, it's important to listen to the sound of each one so you can evaluate its contribution to the bigger picture.

Photo: Richard Ecclestone



Multi-miking can only provide decent scope for sound-shaping if the individual mics are sonically contrasted with each other. One way of achieving this is to use a variety of different microphone designs — like the ribbon, large-diaphragm capacitor, and dynamic models close-miking the guitar amp here.

» So, no matter how many mics you put up at once, it's paramount that you listen to each one of them critically to ensure they're actually contributing something useful. A great way to discipline yourself to do this is first to put up just one mic, and to concentrate on trying to capture the whole sound through that. Only once you've given that a proper shot should you then ask yourself: "What else does the sound need?" You may be surprised how often the answer is, "Er... nothing, really!", in which case it's perfectly OK not to put up any more mics! But if you do identify some element of the sound that needs extra support, then you've immediately got a head start in terms of deciding what mic to add next and where to put it.

Let's say you've already got a dynamic mic right over your guitar cab's speaker cone delivering plenty of upper-midrange bite, but you want more solidity or warmth to the tone. It stands to reason that you'll probably want your second mic to be smoother-sounding (perhaps a neutrally voiced large-diaphragm capacitor or a ribbon), and you might want to place it off-centre to the cone, or a couple of feet away — or even around the back of the cab!

This basic principle is probably most frequently forgotten when multi-miking drum kits. I often hear overhead mics covered in thrashy hi-hat, but with dull-sounding snare ambience. Then, when I investigate the other drum channels, I find there's a completely unnecessary mic on the hi-hat, while the snare has only a close mic on the top head that goes 'donk!' Where the

hell is the final snare sound supposed to be coming from? Just listening to the overheads and asking, "What else does the sound need?" could have headed off this problem, perhaps by repurposing the hi-hat close mic under the snare.

### Listen For Contrast

Another excellent rule of thumb when multi-miking is that you should endeavour to make the mics sound appreciably different from each other. In a sense, this is an extension of asking yourself, "What else does the sound need?", because "more of what I already have" seems like a pretty lame answer to that question! But the other big reason for contrasting your multi-mics is to provide greater sound-shaping power from the control room. The more individual each mic sounds, the wider the range of timbres you'll get as you fade between them. This is why well-known producers so often talk about combining different mic types when multi-miking, for instance, such as dynamics versus ribbons versus capacitor mics, or bright mics versus dull mics.

Contrasting your multi-mics isn't just about increasing flexibility at mixdown,

either, because the biggest appeal of multi-miking in my opinion is how much it can accelerate sound-hunting during the tracking process, particularly when overdubbing electric guitar layers. After all, it's a whole lot quicker to adapt your recorded sound for each guitar part by waggling a few faders than it is by repeatedly shuffling mics around — especially if you don't have an assistant to do the legwork, so have to dash back and forth between live room and control room to evaluate each new option for yourself.

### Managing Polarity & Phase

That said, the fader level of each of your multi-mics isn't the only thing you need to consider, because multi-mic signals will usually interact with each other in complex ways on account of the polarity and phase relationships between their signals. Recording a guitar cab both from in front and from behind, for instance, will cause the back mic's signal to be polarity-inverted compared with the front mic, and if you don't compensate for that by flipping the back mic's polarity while recording, you'll likely discover that the



Photo: Daniel Pieppert



## Thank you!

We're extremely grateful that you, the SOS readership, chose our 8381A Adaptive Point Source Main Monitor as the Best Studio Monitor in the 2024 SOS Awards.

Since 1978, we've been passionate about setting the highest possible standard for truthful audio monitoring in any space. So, having you stand behind this pioneering milestone in floor-standing, adaptive main monitoring makes us very proud indeed.

To learn more, visit [www.genelec.com/8381A](http://www.genelec.com/8381A)



**GENELEC®**



» phase cancellation that occurs when you mix it with the front mic actually thins the combined tone, rather than filling it out — in other words, it'll do the opposite of what you'd expect from listening to each mic on its own! Likewise, if you're multi-miking a snare drum from both above and below, or a kick drum from both the resonant-head and batter-head sides, then it's common studio practice to polarity-invert one of the mic signals to achieve a fuller mixed tone.

But even when you're only multi-miking an instrument from one side, if the sound waves reach the mics at different times, you'll get timing

offsets between their recorded signals, which can also cause unexpected (and sometimes quite drastic!) frequency interactions between them when mixed together — an effect usually called comb filtering. Fortunately, you don't need to know all about the physics of comb filtering to stay out of trouble when tracking, because there are a few straightforward practical ways you can either minimise it or else turn it to your advantage.

The first option is just to place all your multi-mics the same distance from the sound source, such that combining their signals will naturally generate

minimal comb-filtering. You have to be quite accurate here, though, because a miking-distance difference of just half a centimetre can still cause noticeable comb-filtering effects, and it can sometimes be quite difficult to tell from just eyeballing a mic exactly where its diaphragm is located. For instance, both the Shure SM7B and Electrovoice RE20 have their diaphragms set back much further from the grille than the Neumann KM184 or Rode NT5 do, but that's far from obvious without dismantling them. Mind you, it's nevertheless possible to phase-optimize your microphone positions by ear. Just mix the mic signals at roughly equal level; polarity invert one of them; hunt for the mic alignment that gives the weakest-sounding result; and finally remove the polarity inversion.

### Comb As You Are

Alternatively, if you don't want to put all your multi-mics equidistant from an instrument, you have to accept that mixing their signals together will inevitably incur some comb filtering, so adjusting the polarity/phase relationships between the mics by ear becomes an integral part of the miking process. The simplest tool at your disposal here is the polarity switch, and it should become second nature to always try flipping the polarity of each channel in any multi-mic setup while listening for the most appealing combination. There's no 'right' setting here, because every setting will still involve some comb filtering — your aim is just to choose the best-sounding variant! You can also refine phase relationships by introducing small delays into some of the channels, or even by using special phase-rotation devices such as the Little Labs IBP or Radial Phazer, but to be honest I think those are overkill for most project-studio tracking sessions as long as you take full advantage of your polarity switches.

You also need keep your wits about you if you pan some of your multi-mics during tracking, because separating those mic signals in stereo will also reduce the degree of comb filtering you hear between them. This might seem like great news on the face of it, but you have to remember that there are plenty of mass-market playback systems that will sum your mix to mono, at which point the phase mismatch between your multi-mics could transform your monster guitar riff into something like a ferret blowing

## When One Mic Is Enough

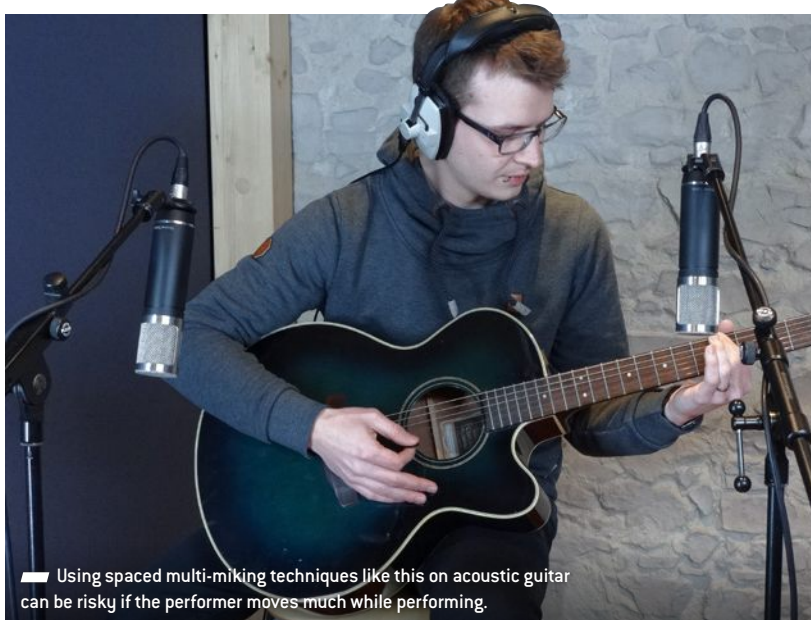

Using spaced multi-miking techniques like this on acoustic guitar can be risky if the performer moves much while performing.

Multi-miking is better suited to some applications than others. For example, it's rarely a good idea to use more than one close mic on any sound source that naturally moves during performance — as a lot of string, wind and brass instruments do. The problem here is that the path lengths to the different mics (and hence the phase relationship between their output signals) will vary with the instrument's movements, so any comb filtering between the mics will modulate unpredictably and it'll feel like some maniac is randomly twiddling your channel EQ the whole time! Because of this, it's little surprise that the most common targets of multi-miking are things like drum kits, guitar/bass cabs and pianos — although things like acoustic guitar and upright bass are also regularly multi-miked, and you can still get decent results there if the player doesn't get too carried away.

If you insist on multi-miking moving sources, though, at least try to mitigate any

potential phase problems by positioning the mics as close to each other as possible and by phase-aligning the signals by ear. Even then, though, I'd almost never recommend recording lead vocals this way, because no matter how well phase-aligned your mic diaphragms, you'll still incur some comb filtering at high frequencies if the singer moves at all off-axis to the multi-mic rig, and that'll usually rob some of the 'air' from your vocal tone.

Another situation where multi-miking can cause more problems than it solves is when you're recording ensembles. You see, if you set up multiple mics on one instrument such that their polarity/phase relationship benefits that instrument's sound, you'll often find that spill from other ensemble instruments starts sounding horrible. Those instruments will have different path lengths to the mics, and hence will incur different flavours of comb filtering. Again, if you really feel you want to multi-mic, then I'd favour coincident mic placements.



■ If you're multi-miking any instrument from different sides like this, then you'll usually find that inverting the polarity of one of the mic signals generates a fuller sound when the signals are mixed together.

raspberries! By all means pan your multi-mics if you want, but never overlook checking the sound in mono too.

### Decisions, Decisions...

Although one of multi-miking's headline advantages is extra control over the final sound at mixdown, I reckon it's a bit

of a poisoned chalice, because it encourages people to defer their sonic decisions, and that's probably the best way to waste time in any studio. If you use multi-miking as an

excuse not to commit to a definite sound while tracking your first rhythm-guitar part, say, then how are you supposed to decide on appropriate sounds for any other later overdubs in relation to that? And how will you know when to stop adding new parts, if you don't know how much mix

real-estate you have left to fill? I've seen plenty of home-studio multitrack projects where they've clearly tried to get around this problem by multi-miking everything, but that's no solution either, because the lack of any sonic vision for each part usually means that those multi-mics aren't suitably placed — not to mention that

**“No matter how many mics you put up at once, it's paramount that you listen to each one of them critically to ensure they're actually contributing something useful.”**

the resultant track-count explosion adds unwelcome logistical complications to all your comping, editing and mixing tasks.

So, if you value your sanity, try to commit to a concrete sound whenever you're multi-miking, rather than leaving that decision until mixdown. By all

means record the microphone signals on separate tracks as a safety measure, but always ask yourself whether you're actually hearing the tone you want while you're still tracking — and if you're not, then change something! Personally, I'll often deliberately mix multi-mics to a single recorder track to force me

not to sit on the fence sonically. Now I realise that might seem a little cavalier. After all, how can I really be sure I've chosen the right sound for the final mix when the production's not yet complete?

Well, it's actually a lot less risky than it appears, because you naturally adapt any subsequent overdubs to fit with the multi-miked sounds you've already baked in, effectively transforming your initial sonic guesses into self-fulfilling prophecies! ■■■



# ADAM Audio A8H



## Active Three-way Monitors

ADAM's A Series speakers continue to impress.

BOB THOMAS

When ADAM Audio replaced their AX series of active speakers with the new A Series last year, they included no fewer than three portrait-format models. The A8H midfield monitor is at the top of the range and, like the others, features onboard DSP-based voicing, room correction, six-band parametric equalisation, Sonarworks SoundID Reference integration and LAN-based remote control.

### Up Front

The A8H's black enclosure features a deeper version of ADAM's signature deep-bevelled baffle, which is designed to reduce cabinet diffraction, and thicker panels to minimise unwanted resonances. The cabinets come in left- and right-handed versions, with the treble and midrange drivers sitting on the inside position, and the 8-inch bass driver and its large, front-facing port on the outer. However, there is nothing to prevent you from swapping them over if you prefer. The port and its internal flare are aerodynamically designed to optimise airflow, minimise port noise and produce greater bass extension and higher efficiency from the A8H's compact enclosure.

The A8H's bass driver is an all-new design based around an MLM (Multi-Layer Mineral) cone made up of layers of mineral fibres baked together to create a lightweight, rigid and very stable composite material. The composition and layering of the MLM and the geometry of the cone are designed to optimise the cone's stability and frequency response. In combination with a new magnet assembly, this new cone enables the A8H to put out high levels of low-frequency output with low distortion. It also looks very attractive.

Frequencies between 400Hz and 3kHz are handled by a new 3.5-inch driver, which is a derivative of the DCH (Dome Cone Hybrid) midrange driver developed for the ADAM S Series. As its name implies, a DCH driver is a part-cone, part-dome hybrid that combines the clean decay characteristic and linear frequency response of a dome driver with the high-excursion advantages of a cone. It too is constructed from MLM, and its dome form factor makes it very stable. This driver also features an underhung magnet system, in which the entire voice-coil winding remains inside the magnet's magnetic field even at extremes of excursion. This achieves linear cone excursion (the entire voice coil is providing motive force all the time) and low inductance modulation, which

translates into improved midrange clarity by significantly increasing the ability of the driver to reproduce multiple simultaneous frequencies without distortion. Overall, the A8H's DCH midrange driver has a frequency response that extends below that of more conventional designs, and also behaves pistonically well beyond its upper crossover frequency, allowing it to deliver clean reproduction across its operational midrange bandwidth.

### ART & Science

The audio spectrum above 3kHz is the domain of ADAM Audio's signature X-ART (Extended Accelerated Ribbon Technology)

## ADAM Audio A8H £2349

### PROS

- Outstanding audio performance.
- Mac/Windows app-controlled DSP-based room adaptation.
- Sonarworks SoundID Reference integration.
- Compact form factor.
- Good low-frequency response courtesy of the 8-inch woofer.
- Attractively priced within its sector.

### CONS

- None.

### SUMMARY

The A8H is a compact active three-way studio monitor that offers excellent audio performance at an attractive price.

high-frequency driver. Handbuilt in Germany, the X-ART's pleated ribbon construction has the same surface area as a 2-inch conventional tweeter and is said to have precise transient response and a frequency response extending to 50kHz. In the A8H, as in all A Series monitors, the X-ART driver sits inside a 120x70-degree HPS (High-frequency Propagation System) resin and glass-fibre waveguide. This waveguide is designed not only to match the X-ART's horizontal dispersion angle in the crossover region to those of the bass and midrange drivers, in order to create a larger usable sweet spot, but also to reduce reflections from studio desks, mixing consoles and the like. Another feature of the HPS waveguide is that it can be rotated through 180 degrees, which allows you to position the A8H vertically or even upside-down, thanks to the M8 inserts on the underside of its cabinet. Finally, a small, multicolour LED sitting in the top of the HPS changes colour to show the A8H's functional status — for example, solid green indicates power on, pulsing green means that it is sleeping, flashing red warns that the monitor is muted, and flashing gold or solid violet mean, respectively, that short- or long-term signal limiting is taking place.

### Power Plant

The A8H's drivers are powered by a hybrid setup: a PWM (Class-D) amplifier provides 200W RMS to the bass driver, a Class-A/B amplifier delivers 55W RMS to the midrange unit and a 15W RMS Class-A/B amplifier takes care of the X-ART tweeter. This combination can cover a frequency bandwidth of 34Hz to 41kHz (+0/-3dB) at a maximum peak IEC-weighted 116dB SPL at 1m from a single A8H, which is far, far above any level that I would want to be listening to in the midfield.

Other than the power on/off switch and the  $\pm 12$ dB input level trim, all A8H rear-panel functions are accessed by momentary push buttons and are under the control of a DSP system that not only provides tuning precision and consistency, but also enables future enhancements and firmware upgrades. Audio input to the A8H can be switched between balanced XLR and unbalanced RCA connectors, with a green LED illuminating next to the selected input.

Like all A Series monitors, the A8H has three DSP-driven voicing options, which are cycled through using the Voicing button. The first two are the flat-response and neutral-sounding Pure and the UNR (Universal Natural Response) presets. The latter, according to ADAM, is a dynamic, natural-sounding response curve based on legacy ADAM loudspeakers, up to and including the previous AX series. The third voicing option is Ext, which is configured using the A Control app's ADV(anced) mode. This not only gives you access to the six fully parametric onboard equaliser bands (each of which can be configured as either high-cut, low-cut, parametric, low-shelf or high-shelf filters) but also allows you to select a Sonarworks room calibration profile if you've already loaded one into the monitor's onboard DSP. As with the inputs, there's an associated rear-panel green LED to visually indicate the selected voicing.

The four-band rear-panel Room Adaptation function allows you to modify the response of the Pure and UNR voicings to help deal with any room or positional issues,

»

# SONTRONICS® RIBBONS REDEFINED

“Sontronics ribbons  
are just incredible!”

TONY ANDERSON, Composer/Producer

“Impressive...  
superb sound”

NEIL ROGERS, SOS Reviewer

“These aren't  
just mics, they're  
works of art!”

Production Expert Review



Here at SONTRONICS®, we know a thing or two about ribbon mics, and our SIGMA 2 and DELTA 2 guarantee stunning results on every take. Employing the highest-grade components, including our own hand-wound transformer, SIGMA 2 is perfect for vocals, wind and strings while DELTA 2 is designed for guitar amps, sax, brass and drums.

Hand-built in the UK and covered by our Lifetime Warranty, SONTRONICS® ribbon mics will change your world.

[www.sontronics.com](http://www.sontronics.com)



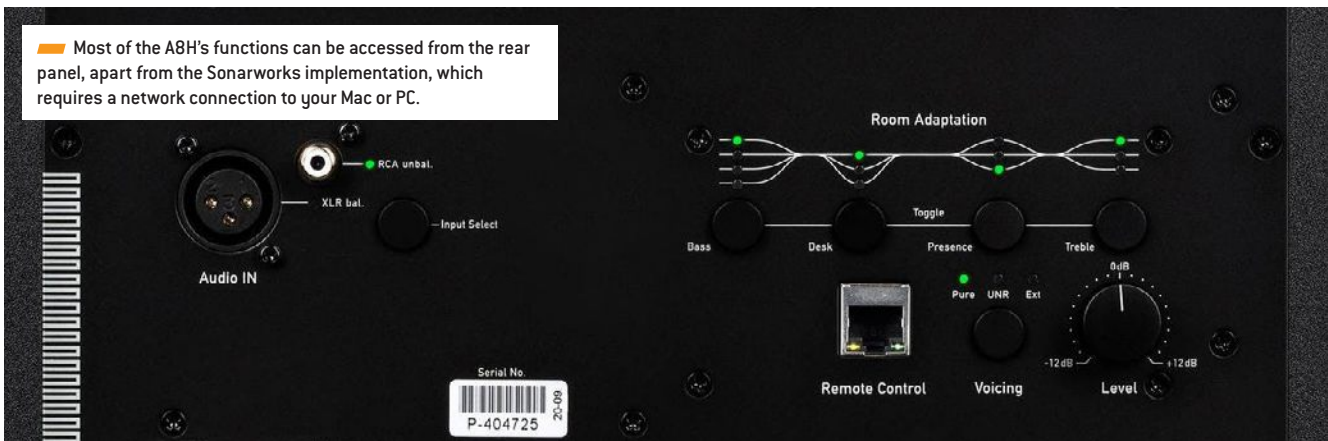

» without requiring the use of a computer. The Bass band is primarily intended to allow you compensate for the increase in bass that occurs when a monitor is placed in a corner or close to a wall, and offers shelving adjustments of +2, -2 and -4 dB, with a corner frequency at 80Hz. The Desk band, as its name implies, attempts to compensate for low-mid issues arising from first reflections from the surface of a desk or console, and is a parametric equaliser that delivers narrow cuts (Q=1.1) of -2 or -4 dB over 1.25 octaves centred on 200Hz. Presence, meanwhile, is a gentle +1 and -1 dB broadband (Q=0.7) parametric adjustment over 1.9 octaves centred on 2.5kHz, intended to enable you to deal with midrange issues caused by room or equipment reflections. Finally, the Treble band offers shelving adjustments of -1.5 and +1.5 dB at a corner frequency of 7kHz, targeting issues arising from either too much or too little high-frequency absorption in a room.

### A Control

Not long after I reviewed ADAM's two-way A7V monitors last year (SOS March 2023), the A Control app was updated to include numerous improvements and added functionality. There's now a built-in firmware updater with automatic update notification; copy/paste when setting up the ADV Room Adaptation six-band parametric/filter; the ability to initiate a factory reset; and an increase in maximum delay time from 5ms to 10ms in 0.1ms steps — which means that you can time-align loudspeakers within approximately 10 feet of the listening position in steps of roughly 1.2 inches.

The app's user interface also gained a slicker look and workflow, which makes connecting and configuring A Series monitors a simple and intuitive task.

It brings the entire process into a single workspace that also includes the ability to select between the RCA phono and XLR inputs. This is a game-changer for those who, like me, not only own vintage kit that operates at -10dBV, but also like to use it!

A 60-day trial of Sonarworks SoundID Reference room calibration software is offered with every A Series monitor purchase, and this program also has been updated since my A7V review. It is now more user-friendly, offering video guidance at every step of the relatively lengthy process of generating a calibration profile.

### Adapt

If you would prefer not to get involved in network cabling and A Control software, and you're able to access the rear of your monitors fairly easily, it is perfectly possible to set up the A8H monitors for your room very effectively with just room analysis software on your mobile phone, tablet or computer and the back-panel Room Adaptation buttons. In my case, given the confines of my studio, the combination of A Control, Sound ID Reference and the monitors' onboard DSP was the only

way to go. Having connected an Ethernet network switch between a Mac Mini (running macOS Monterey) and the two A8Hs, all that remained was to make the monitors active in the A Control UI, run the SoundID Reference calibration process, export the calibration file in ADAM Audio format, and load it into the A8Hs' DSP from A Control.

Since the A Control app gives you full remote control of all the A Series DSP functions, and can store multiple versions of Room Adaptation, Voicing and six-band parametric filter setups (and multiple room calibrations, if you like to take your monitors with you wherever you go), you can set up profiles for various situations — tracking, overdubbing, spoken-word recording, mastering, listening for pleasure — and recall any of these at will.

### Performance

When I began listening critically to the A8H, the first thing that struck me was its speed, taut precision, transient response and low-frequency extension. As usual, I'd opened up with Deadmau5's Grammy Award-winning *4x4=12*, an album

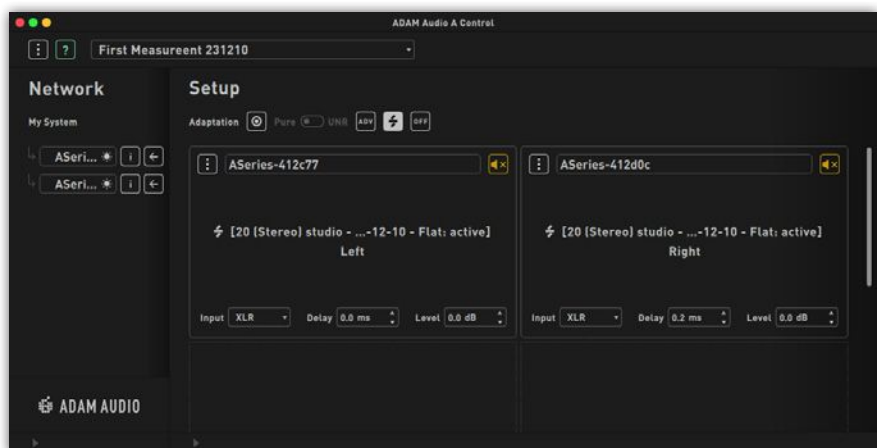

» The ADAM A Control app lets you upload your own custom SoundID profiles to the A8H over Ethernet.

## ALTERNATIVES

You'll find active three-way compact monitors from **Dynaudio** and **EVE Audio** sitting at price points either side of that of the **A8H**, together with higher-priced alternatives from the likes of **Genelec**, **Neumann** and **Focal**.

whose detailed synthesized low end is a stringent test of a loudspeaker's ability not only to accurately reproduce low frequencies, but also to reveal the detail inherent within them. With a superb performance in this area helped, no doubt, by having its -3dB point at 34Hz, I'd be absolutely confident in making low-frequency tracking and mixing decisions on the A8H. Mind you, if EDM and the like were a core part of my work and I needed to accurately monitor down to 25Hz or thereabouts, I could see myself happily adding an ADAM Sub12 subwoofer...

The A8H's midrange is extremely revealing. Crossing over at 400Hz and 3kHz, the A8H's DCH driver delivers an articulate, highly detailed and precise midrange with a clarity and presence that helps to pinpoint sources precisely in the stereo soundfield. This ability came to the fore not only in the A8H's superbly delineated reproduction of the complex harmonic and transient interplay between the baroque instrumentation and powerful vocal performances of L'Arpeggiata's *Via Crucis*, but also in reproducing the midrange detail in both synthesizers and vocals of *4x4=12*.

When it comes to reproducing high frequencies, ADAM Audio's X-ART tweeter offers a superb level of clarity and detail in a seemingly effortless manner. One of my monitor benchmarks is the ability to reproduce the high-frequency detail of echoes and reverberations — a mark that the A8H passed with ease.

However, perhaps the most impressive aspect of the A8H's performance is the manner in which these three drivers come together to produce a coherent, totally integrated performance. The monitor as a whole has a wide, deep, highly detailed and solidly centred soundfield, in which all elements are clearly defined and precisely located. Mind you, the A8H in Pure mode, or with an active SoundID Reference calibration file running, is ruthlessly revealing, so for tracking, writing and recreational listening I have stored room adaptation profiles created with the six-band parametric EQ/filter that are more forgiving.

## Conclusion

Having owned ADAM's A7X monitors, and having reviewed the A7V a few months ago, I had an idea of what I might expect from the A8H, but its level of performance in my listening room exceeded all my expectations and preconceptions and had me reaching for my credit card.

With an outstanding audio performance coupled with an attractive price, to me the ADAM A8H represents terrific value for money. Whether you're looking either to purchase your first pair of active three-way monitors, or to upgrade or replace your existing speakers, the ADAM A8H should very definitely be on your audition list. I've purchased the

review pair, so my money is very definitely where my mouth is, and my ears are too. **///**

£ £2349 per pair including VAT.

W [www.adam-audio.com](http://www.adam-audio.com)



# MIDI

## IT'S WHAT WE DO

35 years of expertise in splitting, merging, converting, controlling and extending the original communication protocol for electronic music production.

**ALSO AVAILABLE**  
THRU-25 and THRU-5



### SPLIT

#### THRU-12

Split a single MIDI source into 12 identical copies

**ALSO AVAILABLE**  
Merge-4



### MERGE

#### MERGE-8

Combine the data from 8 MIDI sources to a single output



### CONVERT

#### MIDI USB HOST MK3

MIDI IN and OUT for USB-only keyboards and controllers



### CONTROL

#### PRO SOLO MK3

Play CV synths from your MIDI keyboard or sequencer



### EXTEND

#### LINE DRIVERS

500m of ultra-reliable, bi-directional MIDI transmission

Contact the MIDI Specialists  
**kenton.co.uk**  
**KENTON**



# Fender Tone Master Pro

## Amplifier, Cabinet & Effects Modeller

Guitar giants Fender join the modelling pedal party with this powerful and comprehensive floorboard. We put it through its paces...

BOB THOMAS

We're almost spoiled for choice today when it comes to high-end amp, speaker and multi-effects floor units, but until recently Fender had been notable only by their absence from this market. Still, their recent launch of the Tone Master Pro did not exactly take me by surprise: the company's Tone Master range already put digitally modelled versions of their most popular valve amps into active combo speaker cabinets, and conceptually it was a short leap from there to a standalone modelling device. What they've delivered is undoubtedly a very powerful device — there's an eight-core processor inside — and as its core technology, hardware and software are new, I would be surprised if Fender aren't planning to develop this platform for years to come. So, was it worth the wait? When Fender reached out and offered to send me a Tone Master Pro and an accompanying FR-10 full-range flat response (FRFR) speaker for evaluation, that's precisely the question I aimed to answer...

### Grand Tour

Presented in a chic black box that would be at home in a Bond Street boutique, the Tone Master Pro (or TM Pro, as I'll refer to it from here) is a visual delight, with curved ends, understated grey, semi-sparkle finish, and a rectangular, semi-transparent panel that occupies the upper 40 percent of its top panel. This panel not only carries the Navigation/Preset View and Master Volume/Mixer View encoders, but also covers and protects the unit's seven-inch, high-resolution colour touchscreen. Below sit 10 footswitches (all but one of which



double as rotary encoders) and two-row scribble-strip screens that display their current assignments. Each footswitch sits inside an LED-illuminated ring, whose colours (which are user-assignable on all but two) change to denote the current function.

A comprehensive set of inputs and outputs on the rear panel are joined by an LED-illuminated version of Fender's traditional red 'jewel' power-on indicator. (Speaking of power-on, the boot-up time seemed a tad longer than on some competing devices). The instrument input

is an unbalanced quarter-inch TS jack and this has a switchable -6dB pad and three input impedances (1MΩ, 330kΩ, and 22kΩ, with or without 330pF of capacitance), designed to simulate the real-world input impedances of modelled effects and amplifiers; these can be configured automatically or manually within a preset. A balanced XLR/TRS combi connector caters for microphone and line-level inputs and can supply 48V phantom power on the XLR. Four send/return loops sit between the input and the input buffer. Loops 1 and 2 are mono and allow the programmed insertion of hardware effects as the first stage of any preset, while loops 3 and 4 can be configured as either separate mono loops or a single stereo loop, and can be inserted into the signal path of any preset at any post-input buffer point.

Output 1 is a balanced stereo analogue output, and this is paralleled on XLR and quarter-inch TRS jack connectors. Output 2 is a single pair of unbalanced quarter-inch jack sockets, and sitting above this are the auxiliary input's 3.5mm stereo mini-jack and a quarter-inch stereo headphone output. Between the latter

two sockets sit two miniature buttons, one initiating a factory reset and the other to invoke a firmware update. A Bluetooth input, separate from the aux input, allows the connection of two separate stereo audio streams of, for example, backing tracks that can be routed separately to the unit's analogue and USB 1 and 2 outputs using the TM Pro's onboard mixer.

There are inputs for two expression pedals as well as one for a toe switch (or any footswitch). The Mission Engineering SP1-TMP pedal, developed specifically for the TM Pro, can connect to one expression jack and the toe switch and this allows you, for example, to configure the pedal to control a wah and use the toe switch to turn it off and on. An Amp Control TRS jack socket offers the potential to switch functions on two suitably equipped external amplifiers. Two full-size MIDI connectors (On and Out/Thru/merge) not only equip the TM Pro to send and receive Program Change and Continuous Controller messages, but also allow the connection of up to four MIDI expression pedals and a toe switch, each of which can be assigned on a preset by preset basis.

## Fender Tone Master Pro

£1649

### PROS

- Impressively realistic emulations — especially of Fender amplifiers.
- Well-designed and easy to use touchscreen and encoder user interface.
- The Pro Control app works well.
- Attractive and competitive price.
- It looks stylish, and it's a Fender!

### CONS

- An occasional minor UI quirk to get used to.
- Doesn't (yet?) model all my favourite vintage Fender amps.

### SUMMARY

A very impressive debut from possibly the best-known electric guitar brand around, Fender's Tone Master Pro amplifier, cabinet and effects modeller delivers a very high level of performance at an attractive and competitive price point.

Above the MIDI connectors sits a micro-SSD slot intended for "future expansion", together with a USB-C port for connection to a desktop computer. Running on macOS (Monterey or later) or >>



➤ All but one of the 10 footswitches double as rotary encoders, to put lots of control at your fingertips.





■ The extensive I/O options include a phantom-capable mic input, as well as 4x4 USB audio interfacing.

» Windows (10 and above), a Tone Master Pro Control app mirrors the TM Pro's onboard functionality and adds in the download of presets from the Fender Cloud and the upload of third-party IRs to the TM Pro. Anything that can be done on the TM Pro can be done in the app, making editing an intuitive and seamless blend of computer and hardware whether the TM Pro is on a desk next to the computer or on the floor. The TM Pro also functions as a 4-in/4-out USB 2 audio interface with two recording modes (standard and re-amping).

In standard recording mode, dry mono tracks from each input are sent to the computer on USB outputs 3+4, while USB outputs 1+2 carry either separate stereo processed tracks from each input channel or, if a dual-channel routing is in use, an overall summed signal. USB inputs 1+2 carry a stereo monitor signal from the DAW to the TM Pro, and USB inputs 3+4 are disabled. In re-amp mode, USB inputs 3+4 carry the dry signal from the DAW to the instrument and mic/line channels

respectively, and inputs 1+2 carry a stereo monitor signal from the DAW. As before, USB outputs 1+2 return either separate stereo processed tracks from each re-amped channel or an overall summed signal when a dual-channel routing is in use.

### Navigation

At the time of writing, the TM Pro ships with 134 factory presets: 129 combinations of amplifiers, cabs and pedals, one putting an acoustic guitar and vocal on parallel paths, and four pedal-only setups. These presets are made up of models including: 24 combos and half-stacks (each of which can be split into heads and cabs); three additional heads; 26 cabs; 21 boosts and distortions; 21 modulation effects; 28 reverbs and delays; five compressors; three EQs; three noise gates; one volume pedal; one auto swell; three wahs, four pitch-based effects; and a microphone selection that includes one ribbon, two capacitors and four dynamics, each

with 64 possible positions, plus variable high- and low- pass filters.

With such a generous selection, navigating through that could have been a nightmare — but actually the touchscreen-based UI makes it pretty easy. It's based on six top-level lists of presets, or Modes in Fender-speak: My Presets, Favorites, Factory Presets, Cloud Presets, Songs and Setlists. My Presets contains a list of the 504 user preset locations and is partially populated by the factory presets. Factory Presets is self-explanatory, while Cloud Presets can contain 100 presets downloaded from the Fender Cloud, and Favorites is a list of user selections from the other preset lists. Factory and Cloud presets can be edited in situ, but as with all edits, the results have to be saved to My Presets or they'll be lost, without warning, on exit. Songs can store a maximum of six footswitch-selectable presets per song for up to 200 songs, and Setlists can hold a list of up to 99 Songs. The contents of My Presets, Favorites,

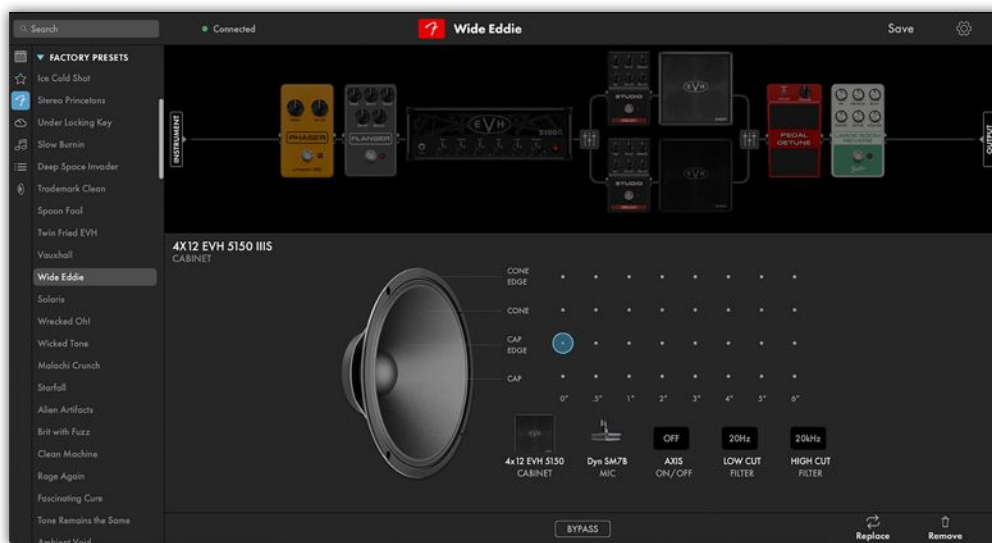

■ The control app makes it easy to select and position your virtual mics on the IR-based speakers.

Songs and Setlists can be freely reordered with a simple drag-and-drop approach.

Individual presets in the My Presets, Favorites, Factory and Cloud lists can be viewed on the touchscreen, either in the all-text List view or in the graphical Preset view of a preset's contents and signal path. In either view, you can use the Navigation encoder to scroll through and select presets, or step through them using the footswitches: the leftmost footswitches handle bank up/down switching in groups of six, and others recall individual presets.

That leaves two remaining

»

# Pro•MB

Multiband dynamics  
redefined

Multiband compression and expansion are powerful tools, but notoriously difficult to set up and control. Enter FabFilter Pro-MB: making multiband dynamics processing intuitive yet powerful at the same time.

Try it now: [fabfilter.com](https://www.fabfilter.com)





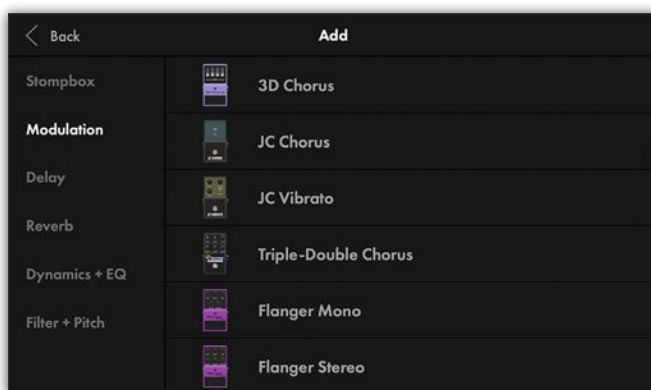
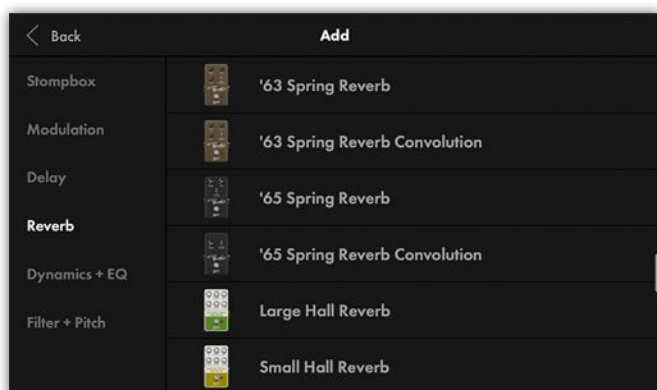

There's a comprehensive range of good-sounding virtual stompbox effects.

» footswitches, and in Preset view a short press on the upper one toggles between the other footswitches' bank and recall mode and their Effects mode, which displays the roles of those footswitches that have been assigned to control blocks in the preset. A longer press activates an easy-to-operate 60-second looper, while a longer press on the lower footswitch toggles between its tap-tempo and tuner modes.

### Preset Editing

Preset editing takes place in Preset view, and will feel instantly familiar to anyone with experience of other floorboard modellers. Effect, amplifier and cabinets ('blocks' in Fender-speak) can be inserted, re-ordered, deleted and edited using the touchscreen. While the Navigation encoder can scroll through a list of presets, that functionality doesn't extend to the list of blocks, so can lead to the occasional accidental rapid exit from edit mode. Tapping a block in a preset zooms it to the fore, where its virtual front-panel controls can be adjusted either on the touchscreen or using any of the up to seven encoders/footswitches that have been assigned to its control. When editing a block, the top-left footswitch is used to cycle through any multi-page control assignments and is held to save an edit, whilst the upper-right exits edit mode when pressed. The bottom-right footswitch's tap-tempo/tuner assignment remains unchanged across all preset-related views and modes. Surprisingly, that footswitch's encoder cannot be used to set the tempo.

Much as I'd like to, going into the mechanics of creating and editing presets in detail would require rather more space than is decent in a magazine review, but I do want to offer an overview. Despite being centred on the touchscreen and

having the odd operational quirk, I found both creating and editing presets to be simple, though I'd still recommend reading through the user manual. For me, a standout feature of the process is the way in which Fender have implemented footswitch assignment in a preset — they've created a very powerful tool. Each footswitch can control up to three assignment types: on/off (which can be assigned to up to five blocks); parameter change (switching between two preset values of a parameter on one block); and amplifier switching on two amplifiers. And this opens up the possibility of creating complex block switching combinations within a preset. One point to note when building presets is that the TM Pro will start to limit access to memory/processor hungry blocks (in particular the effects spillover as presets change) in order to protect its performance level.

### The Playing Experience

Having owned a good many vintage and reissue Fender amps over the years, I'd hoped that the TM Pro would feature many of the classic circuits, so I was somewhat disappointed to discover that its list of Fenders contains only combos. These are the five members of the existing Tone Master series, plus three emulations of the Bassbreaker's Structure (gain) settings, a Blues Junior, a 3x10 Vibroking reissue, an Acoustasonic head, and both a solid-state and a valve preamp. But this isn't all about Fender emulations: Fender appear to be aiming at a wider market, and to that end they've also included combos from Vox and Roland, and half-stacks from Marshall, Friedman, EVH and Bogner. All of these, as with the Fender combos, can be split into their constituent heads and cabs, with additional cabs expanding the available choice.

The Fender combo guitar amp models were impressively realistic, and they felt good under my fingers too, especially through the matching Tone Master FR-10 active FRFR cabinet. The Acoustasonic head partnered well with my acoustic guitars, both piezo and magnetic, and the solid-state and valve preamplifiers worked well, in particular as electric, acoustic and bass guitar DIs. The models of the non-Fender amplifiers were equally impressive, notably the Vox AC30 Normal and Brilliant emulations and the Roland JC-120 emulation, both of which have everything that I like about those amplifiers.

Although I've owned a Mesa Boogie MkIII combo, a Triaxis/2:Ninety combination, and a small-box 50W Plexi Marshall, none of those are covered by the TM Pro, so I don't feel sufficiently qualified to comment authoritatively on the accuracy (or otherwise) of the TM Pro's emulations of Mesa Boogie, Marshall or of those amps and cabs from the other manufacturers. But all sounded great and felt good to play through, even if some models were more to my tonal tastes than others. On top of everything else, the TM Pro's selection of cabinet IRs with their 64 possible microphone positions, choice of seven microphones and their high- and low-pass filters offers an amazing degree of cabinet customisation, and if you feel that even this isn't enough, there's the option to upload third-party IRs via the TM Pro Control app.

The TM Pro's collection of boosts, distortions, time-based effects, reverbs, dynamics, filters and pitch-shifters sounds good and is also comprehensive, to say the least. It kept me occupied for far too long, auditioning old friends and new acquaintances in a pedal collection that my wallet could only dream of. If you'd

like to check out what's available, you can find a PDF file with a full list of TM Pro models at: <https://tinyurl.com/48yv4e6k>.

### Overall

Since the Fender Tone Master Pro is more of a platform than a fixed product, you'd like to think there is plenty of scope for expanding its capabilities. That mysterious rear-panel micro-SSD slot hints at promise for the future, and I look forward to seeing where this leads — especially if it brings with it models of every Fender amplifier ever made from the 1946 Woodie onwards!

But even at this early stage in its life cycle, at this price I reckon the Tone Master Pro is a very attractive and good value proposition for guitarists who are looking not only to enjoy playing through a collection of amplifiers, cabinets and effects, but also for a realistic user experience — that's a combination that it definitely delivers, particularly when paired with its matching active FR series of FRFR cabinets. If you're in the market for an amplifier, cab and

Released alongside the Tone Master Pro are two full-range, flat-reponse Class-D-amplified speakers, the FR-10 and FR-12.



effects modeller for this sort of price, then, I highly recommend that you add Fender's Tone Master Pro to your list of potential purchases. **///**

£ Tone Master Pro £1649. FRFR speakers: FR-10 £469; FR-12 £519. Prices include VAT.  
 E [contactemea@fender.com](mailto:contactemea@fender.com)  
 W [www.fender.com](http://www.fender.com)



# ATLAS i8 3-WAY ISOBARIC ACTIVE MONITOR

**TOP-NOTCH AMPLIFICATION.**  
 Custom-designed Class-D amplifiers offer superior clarity and minimal distortion.

**LESS SPACE, MORE BASS.**  
 Dual 8-inch isobaric woofers deliver unparalleled depth and detail.



**COAXIAL FOR THE MIDS AND HIGHS.**  
 Experience precise mid and high frequencies with a coaxial arrangement.

**DIGITAL PRECISION.**  
 A proprietary DSP with FIR and IIR filters provides deep and focused stereo image, precise transients and fatigue-free studio sessions.

## A NEW SONIC VOYAGE.

-   
 2 x 8-inch woofers (isobaric)
-   
 Coaxial drivers for mid & high frequencies
-   
 Frequency range of 35-20 000Hz
- 117 dB**  
 Max. peak SPL per speaker at 1 m
- 400 W**  
 Custom Class-D amplifier
-   
 Factory calibrated using FIR & IIR filters
-   
 64-bit Acoustically Focused Clocking
-   
 192kHz sample rate
-   
 Analog + Digital AES inputs



# MODULAR

## Befaco FX Boy

Eurorack Module

A Gameboy cartridge-based Eurorack effects module? I didn't see that coming. I mean, who would decide that using an obsolete form of programming delivery to build a multiple effects unit in which you have to physically replace the guts of the module to change effects was a good idea? Well, Befaco do, and so we have the chunky FX Boy with all the finesse of a handheld gaming machine.

On first impressions, I couldn't quite decide if it was ridiculous or extremely cool in a vibey, retro, 8-bit '90s kind of way. But once I started working with it, I think what sold me on it was that the act of changing effects is so satisfying. Oh sure, you can have an encoder to select your effect on a multi-effects unit, but with the FX Boy you can yank out the current effect and slap in a new one and feel wild and free while you're doing it. This is helped a bit by most of the effect cartridges being massive overdriven crushing effects, so when you hot-swap in that cartridge, it feels like your modular explodes!

A number of different manufacturers have developed cartridges, and currently, they are all included with the module. We have a harsh fuzz from Touell Skouarn, a micro-phaser from Instruo, a flanger from Feedback Modules, a delay and granuliser called FX Girl from XOR, an analogue wavefolder from Making Sound Machines, a bit-crusher from Tesseract and a trash distortion from Befaco. The distortion-based effects are the most dramatic, and sometimes the levels of the more subtle effects feel uneven in comparison. However, they are all exciting and feel very controllable embedded in the FX Boy. Making Sound Machines wins the prize for the most visually pleasing cartridge because they built in some very jazzy level LEDs.

The FX Boy module features more than just the slot for the cartridge. You've got two large X and Y controls that run two parameters within the effect. There's also a dry/wet mix knob, and all three of these can be modulated. A small A/B switch flips the effect between two different versions. On some of the cartridges, these are two entirely different effects. The



bottom half of FX Boy features an unexpected and CV-controllable four-band EQ. You can switch it to before or after the effect, but you can't use it on its own. The audio routing is such that if no cartridge is present, there's no wet signal. While you can apply the EQ before the effect, the audio isn't reaching the output unless a cartridge is in the slot.

The last cool factor is that the cartridge design is open source and invites the possibility of making your own. You get an unpopulated PCB prototyping cartridge with the module and documentation on what the connections are. The FX Boy has two VCAs and two op-amps that can be routed to/from the cartridge to help minimise the complexity of your design. I made my FX Boy from a kit, which was a good, solid build, but I have no idea where to start with designing my own effect. It's definitely something I intend to look into, though.

I'd like to see the range of effects expand into a few more flavours, but what we have is pretty epic. I'm still enjoying the hot-swapping of effects; it feels very deliberate and interactive. My only concern is the possibility of misplacing them. Otherwise, the FX Boy is fiercely good and can only get more interesting as new cartridges appear, or you make your own. *Robin Vincent*

£ £369

W [www.befaco.org](http://www.befaco.org)

## What's New

Good news for Spanish readers: January 15th saw Bristol modular mainstays **Elevator Sound** — the folks behind the most excellent Machina Bristonica show — open the doors of a brand new branch in Barcelona.

[www.elevatorsound.com](http://www.elevatorsound.com) Speaking of shows, the excellent **Synth East** is just around the corner, taking place on the 23rd-25th February at the Norwich Arts Centre and featuring the likes of Blancmange, Ultramarine and the UK premiere of a new film about the great Morton Subotnick.

[www.syntheast.com](http://www.syntheast.com)

We last checked in with Moritz Klein and **Erica Synth's** mki x es.EDU DIY range last year, and they've not been complacent since.

Following the release of a kick drum module over the summer, the latest addition to the line is an analogue TR-808-inspired hi-hat.

[www.ericasynths.lv](http://www.ericasynths.lv)

We've also been keeping a keen eye on **Schlappi Engineering** since catching wind of their fearsome Three Body oscillator; latest from the developer is The Nibbler, a 4-bit digital accumulator outputting wildly syncopated gates and stepped voltages.

[schlappiengineering.com](http://schlappiengineering.com)

**Happy Nerdin**, meanwhile, have adapted their popular 4HP FX Aid multi-effects module into a 24HP 1U version, offering the same 32 algorithm slots and a bank of over 100 to draw from.

[www.happynerdin.com](http://www.happynerdin.com)

*William Stokes*



## Noise Engineering Basimilus Iteritas Alia

Eurack Module

There are some modules that seem to be everywhere, in everyone's cases, in every YouTube video you see. Not necessarily front and centre, but always there, to the side, doing their thing. Noise Engineering's Basimilus Iteritas is one of those — everybody seems to have one. But why? Well, one suggestion could be that like the ubiquitous Maths or Pam's, the Basimilus is almost too versatile not to have. In terms of function per HP, if you want drum synthesis Basimilus is hard to beat — its six-oscillator additive and FM synth engine can deliver kicks, snares, hats, claps and all manner of delightful crunchy weirdness with idiosyncratic panache. And it's not just a percussion module — it's a synth voice capable of bass, leads, gentle ambient plinks or just plain noise chaos. And if you get the CV right it can do all of the above more or less simultaneously — look up Baseck jamming with one for some serious inspiration. Another suggestion is that its kick drums alone are good enough to justify its place in anyone's rack and everything else is just a bonus.

So it's pretty good, then? Well most of you probably already know that — chances are high you own one. Understandably, then, there was considerable consternation when Noise Engineering announced the demise of its second generation back in the summer, apparently because crucial components used to make it were themselves being discontinued. But fret not — as you will already have gathered, the third generation is here.

Named Basimilus Iteritas Alia and redesigned to include non-discontinued chips, the latest version is part of NE's new Alia platform. Similar to the existing Legio and Versio platforms, this means you can buy one module and then freely — as in it's free — swap the software to another module in the range as you so choose. The other Alia modules currently available are the Debel Iteritas and the Manis Iteritas, a 'hybrid additive phase modulation voice' and a 'gritty industrial voice' respectively. By the time you read this these will have been joined by Alia versions of Cursus Iteritas Alia and Ataraxic Iteritas Alia, along with a new module called Incus Iteritas Alia.

The software and printable front-panel labels can be downloaded from the NE website, where, after setting up an account,

you'll also find the NE Firmware Wizard. You'll have to remove the module from your case to access the micro-USB port on the back, and from then on it's simple to let the wizard do its (his?) thing and swap the firmware. Pop it back in your case and off you go again.

One of the joys of the Basimilus Iteritas Alter is that all of its front-panel controls can be addressed by CV. This remains the case with the Alia, but like someone eyeing a bulging suitcase and thinking 'I can get one more pair of socks in there' Noise Engineering have managed to squeeze in an additional output, an Env Out socket that outputs the envelope set by Basimilus' attack and decay controls. Useful for layering other voices for world-ending percussion sounds or for patching straight back into the BIA for modulating its front-panel inputs — controlling the Morph with Env Out produces some pretty authoritative kick drums — the addition also evens out the number of sockets, which is good news for fans of symmetry.

This latest iteration leaves the character of Basimilus unaltered, but throws in an envelope output and a range of extra modules for free. BIA has always punched above its weight (or width) in the function per HP stakes and that ratio just got even better. *David Gasper*

£ £379

W [www.noiseengineering.us](http://www.noiseengineering.us)



## Mixers Modular Round-up

They're the modules we only start to take seriously once it's too late: by the time you have enough separate outputs in your system to warrant one, you need no telling how valuable mixers are to your workflow — be it in the studio or performing live. Mixers are in many ways the nerve centre of a system; while often they (rightly) constitute the last link of the chain before signals flow beyond the bounds of our rack, they can also be invaluable within a patch. Developers are playing with mixer formats and functions now more than ever, and there's a staggering range out there to choose from. Larger mixers will likely constitute the pricier end of your module collection, but there are also a host of more compact and wallet-friendly options out there. Here is a round-up of some of the best mixers on offer right now:

### 1010music Bluebox Eurack Edition

1010's latest promises big things for those looking for a powerful mixer that considerably stretches the bounds of what a Eurack mixer can be. With 12 inputs, four outputs and six assignable CV inputs, the touchscreen module boasts a raft of premium functions: MIDI over USB or TRS, onboard effects, four-band EQ and bus compression— it even supports two-channel audio over USB to render it a functional audio interface. No computer?





» No problem: the Bluebox can internally record audio as 48kHz/24-bit WAVs and also play back and record simultaneously if desired. Impressive.

£ £665

W [www.1010music.com](http://www.1010music.com)

**Noise Engineering Xer Mixa**

Hot off the assembly line, Noise Engineering’s new large-format mixer promises big things for even the heftiest of systems. With a whopping 10 stereo-paired inputs (including two aux ins) and three stereo output



busses, the Xer Mixa utilises a fully analogue signal path with pristine sound quality and ultra-high headroom. It’s smart, too: digital control allows for state save and recall, pre or post send settings, multi-channel editing, MIDI I/O settings and even per-channel pan law adjustment. The Xer Mixa also supports an expansion module, the brilliantly named Expando Expandi — up to two, in fact — allowing additional CV control over channel levels, pan, aux sends and more.

£ £995

W [www.noiseengineering.us](http://www.noiseengineering.us)

**Cosmotronic Cosmix Pro**

A gorgeous middleweight mixer, the Cosmix Pro from Dutch designer Matthijs Munnik’s company Cosmotronic



crams a huge amount into a relatively modest 22HP. Four mono channels and two stereo channels make a total of eight possible inputs, and it offers two post-fader aux sends — one mono and one stereo. CV inputs for the two stereo pairs make for some creative imaging potential, but particularly handy is a set of switches at the bottom of the panel; these engage a low-cut below 80Hz for the four mono channels, and an 18dB gain boost on the two stereo channels for getting signals up to modular level.

£ £349

W [www.cosmotronic.nl](http://www.cosmotronic.nl)

**Xaoc Devices Ostrawa**

Xaoc have eschewed the traditional mixer layout in favour of what you might deem more Eurorack-friendly; opting to have its level controls at the top of the panel and its inputs and outputs at the bottom. Four channels of quality op-amp-driven stereo goodness are on offer, alongside a stereo aux send, which is switchable between pre and post VCA. There’s also an expander available, named Bohumin, which adds a second



stereo aux send with CV control, among other features. On top of this, Xaoc have also made the Ostrawa chainable, either with more of the same or with Xaoc’s ‘sister’ mixer module, the Praga, so your I/O can expand with your system.

£ £430

W [www.xaocdevices.com](http://www.xaocdevices.com)

**WORNG Electronics Soundstage II**

Aussie developers WORNG Electronics’ original Soundstage went down so well on this side of the globe that the UK’s ALM/Busy Circuits later sought out designer Morgan McWaters to collaborate

on the more compact Jumble Henge, which I reviewed favourably back in 2021. More recently WORNG’s Soundstage II has arrived; all of the above are stereo ‘spectral’ mixers, whose designs revolve around a simple grid of inputs. Lateral positioning of a signal corresponds to its placement across the stereo image, while vertical positioning corresponds to its placement up and down the frequency spectrum, thanks to each input row having its own tuned filter. The Soundstage II builds on the fundamentals of its predecessor with an updated Depth control circuit, an effect send and return, an improved low-end response and more.

£ £379

W [www.worngelectronics.com](http://www.worngelectronics.com)

**Instruō Càrn**

Predictably pretty, the Càrn from Glaswegian company Instruō is an incredibly compact four-channel mixer offering a raft of useful features in just 8HP. The company, I should say, actually refer to the Càrn as “a four channel signal processing utility,” which is respectable since it can do a whole lot beyond summing several signals to stereo. Individual outputs for each channel are on offer, as is CV-controlled amplification and panning. There’s also a supremely useful soft-clipping limiter, whose switch is accessible on the back of the module.

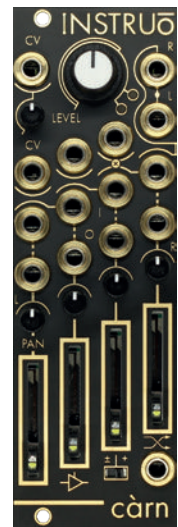

£ £379

W [www.instruomodular.com](http://www.instruomodular.com)

**Bastl Instruments Aikido**

Bastl’s take on the compact mixer format throws some excellent functions onto the table. It can be happily used as a quad DC-coupled VCA as well as a summing mixer thanks to its per-channel attenuverters, but it also boasts some very interesting routing options: there’s not only a side-chain input and envelope follower, there’s also a spectral follower which can be switched to focus on high, mid, or low frequencies.

£ £269

W [www.bastl-instruments.com](http://www.bastl-instruments.com)

William Stokes



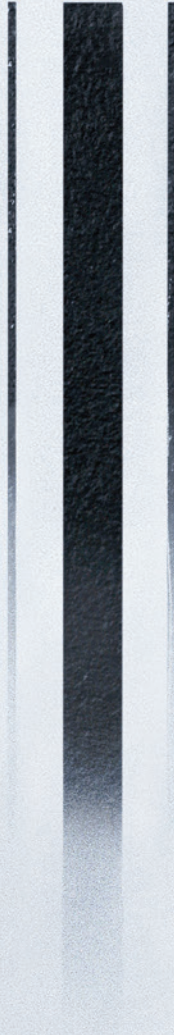

BENJAMIN WALLFISCH  
STRINGS

 ORCHESTRAL TOOLS



# INSIDE TRACK

## Andrew Wyatt: *Barbie*

The amazing success of the *Barbie* movie was powered by its music. Mark Ronson and Andrew Wyatt were the producers, songwriters and composers who helped to turn the world pink.

PAUL TINGEN

Released in July 2023, *Barbie* became the highest-grossing live-action comedy of all time, Warner Brothers' highest-grossing movie, and the highest-grossing movie of the year. It was also a major event musically. With songs featuring Lizzo, Dua Lipa, Nicki Minaj, Charli XCX, Sam Smith, Billie Eilish, the Kid Laroi and many more, the accompanying album went to number one in many countries, while the instrumental *Barbie (Score From The Original Motion Picture Soundtrack)* became the most successful soundtrack album of the century so far. The two albums received a whopping 11 Grammy nominations between them.

Surprisingly, the score album was written by two people who had no previous experience of writing a movie score: Mark Ronson and Andrew Wyatt. The duo also co-wrote three and co-produced five of the songs on *Barbie The Album*, including two of the biggest hits, Dua Lipa's 'Dance The Night' and Billie Eilish's 'What Was I Made For?'

"It feels good to be part of a cultural phenomenon that brought people





MATTEL

Barbie



back into the movie theatres,” says Wyatt. “It’s also really cool because it’s the first scoring gig Mark and I have done together. Mark has done the soundtrack for a movie called *Mortdecai* [2015, with composer Geoff Zanelli providing the score], but that seemed to be more an extension of what he did on his album *Version*, with the Daptone horns. This was the first time both of us had to score a film and bring in orchestral elements.

“We worked 10 to 15 hours a day for several months. In addition, because Mark was also doing the executive production of the soundtrack, he got no sleep. And he just had a kid. He’s a beast!”

### Something In The Woodshed

Andrew Wyatt first came to prominence in 2009 as singer and songwriter with the band Miike Snow, and two years later as co-writer of Bruno Mars’ megahit ‘Grenade’. He released a solo album called *Descender* in 2013, and a couple of

solo singles in September 2023 as a precursor to a second solo album. In addition, the fourth Miike Snow album will soon see the light of day.

Wyatt has an extremely prolific parallel career as a songwriter and producer, working with artists like Charli XCX, Mark Ronson, Beck, Dua Lipa, Florence + the Machine, Lady Gaga, Liam Gallagher, Lorde, Miley Cyrus, Major Lazer and Yeah Yeah Yeahs. Wyatt has also created sound installations, and together with Mark Ronson, wrote music for a ballet called *Carbon Life* (2012). The *Barbie* movie thus brought together the full range of Wyatt’s musical interests.

“I see myself as a weirdo who loves to experiment,” he comments. “I’ve spent a lot of time exploring all kinds of domains in music. I find them all fascinating and rewarding, in different ways. There’s always some new skill to acquire. I started my path as a jazz pianist, and in my first band there were people who had played in Ornette Coleman’s band, and Greg Kurstin, who is a great jazz pianist, and saxophonists Chris Potter and Walter Blanding Jr.

“The jazz tradition is closely related to the classical tradition in that the main feature is not to be famous or to create work that is famous. The main thing is what in jazz nomenclature is called ‘woodshedding’. The term comes from the days when jazz musicians in the rural South would go the toolshed, or even the latrine, to practice their trumpet or saxophone, because it would drive the family crazy if they did it in the house.

“Woodshedding became the idea of setting time apart to learn a new musical skill, almost like a researcher, and it’s very different from being famous. I feel very lucky to be able to devote myself to the more academic side of music, and promote innovations. That’s the tradition I come from, and it’s one reason why I have been in the business for so long. I constantly remind myself that the most important thing is to deploy all my talent and intelligence to try and solve problems in new ways.”

### All That Jazz

Wyatt’s jazz career goes back to late-’80s New York, when he played in bands called Fires Of Rome and Funkraphiliacs. The latter featured the aforementioned Greg Kurstin, who went on to become one of the world’s most famous producers. For a while, Wyatt also studied at the School of Jazz and Contemporary Music. “I was kicked out because I never went to class! I felt that the jazz community was trying to roleplay being in the 1950s, and I wanted to make modern music. So I got a job at a studio called Marathon Recordings, which led me on the production path I’ve been on ever since. This was around 1990. I also got a record deal with Capitol as a solo artist. However, I went crazy and became a drug addict for 10 years. I didn’t start making music again until the beginning of this century, when I was about 30.”

Wyatt returned to music by being the bass and keyboard player of a band called the AM, who released one self-titled album in 2003. He continues, “A few years later, one of the guys I knew from my Capitol days asked if I was interested in writing for some of his artists on his new Downtown Publishing company. I was one of the first to sign for that company. He sent me to Sweden to work with production duo Bloodshy & Avant, which is how Miike Snow was formed.

Mark Ronson (left) and Andrew Wyatt at the premiere of *Barbie* in LA.







Photo: Alex Venguer / @boomermindsstudios

Some of the orchestral material for the *Barbie* soundtrack was recorded at New York's Manhattan Center by engineer Alex Venguer. "We brought in a bunch of outboard pres, including vintage [Telefunken] V77s for the Neumann M50s on the Decca Tree, some Burl and Chandler preamps and my vintage API 312s. We also had four Telefunken ELA M251s as the string spot mics — two reissues and two vintage, plus Mark Ronson's RCA77s he used on Amy Winehouse's vocals, which we used as brass section mics. Add in the usual suspects and my Mesanovic stereo ribbon and the Nordic Audio Labs NU100ks as my main wide pair, and my trusty Blue Microphones omni mics as string overheads, and we were set with great sounds."

» "Around the same time I met Mark [Ronson], and we became close friends, and have since had a great time working on music. It's hard to find people that you can have a great creative partnership with, and also get on with personally. We also had luck on our side, because the first song we did together became a hit in the UK in 2009.

"When we first met, I was more the songwriter and Mark the producer. I'd say he's still more the producer than I. He asks for my opinion, of course, but I tend to trust his instincts. I mean, he's one of the greatest producers ever in pop music! Over the years his songwriting has improved, and I think as songwriters we're 50/50 at this point. Sometimes one of us will start a song and the other will finish it, and *vice versa*."

Their breakthrough hit song, 'Change', was co-written by Wyatt with the artist, Daniel Merriweather, and produced by Ronson and Wyatt. When Wyatt co-wrote 'Grenade' with Bruno Mars not long afterwards, his status as one of the

world's top songwriters was assured, resulting in a swathe of major credits, amongst them a co-write of Lady Gaga's Grammy-Award winning song 'Shallow' for the movie *A Star Is Born*. Less known is the fact that Wyatt co-wrote much of *The Fall* (2015), the debut solo album by Emile Haynie, another of the world's top producers.

### Hand In Hand

The Ronson-Wyatt collaboration reached peak prominence with the *Barbie* movie. It started with an innocuous-sounding request in 2022 to Ronson from the co-writers of the movie, Greta Gerwig and Noah Baumbach, and music supervisor George Drakoulias, to write a couple of songs: a dance track for Barbie, and a song for her male counterpart, Ken. Ronson started work on an instrumental dance track in his New York studio, with help from production duo the Picard Brothers, and he invited Wyatt in as well. The decision was later taken to invite Dua Lipa to add vocals.

"The agreement was to work on the song with Dua and her topline writer Caroline Ailin," recalls Wyatt. "But I was working on a lot of stuff with Dua for her new record, so she asked if she could bring me in. It was a very weird coincidence! We ended up doing a bunch of different versions of the Barbie song, because Dua is very hands-on and decided that the verses weren't really flowing with what was happening on the screen. She wanted to add lines that coincided with some of the things that we were seeing, like when Margot Robbie gestures and goes 'Come along for the ride!' This in turn influenced the movie.

"In a weird way, we ended up working like they do in Bollywood films, with directors writing movie scenes to the songs. Mark had first made a very raw demo of the instrumental of what became 'Dance The Night', with no lyrics or vocals, and he had sent that over months earlier, so the choreographer had something to create choreography to. The music influenced the choreography, and then



more lyrics were created responding to the new visuals.”

A similar two-way process played out with the second song Ronson and Wyatt wrote for the movie, ‘I’m Just Ken’. They had been given some basic, throwaway suggestions (“Ken likes horses, has no genitals, wants to be hugged”), suggesting a throwaway song. Instead, the two-way process transformed ‘I’m Just Ken’ into an anthemic power ballad, or, as Ronson put it, “a wonderful heartbreak epic that’s totally batshit”.

Wyatt: “Mark came up with ‘I’m just Ken, anywhere else I’d be a 10,’ and the melody and chords for the chorus. I helped him finish the melody for the chorus and the lyrics, and then we wrote the verses. We basically created a very short song that was verse, chorus, one instrumental section, and another chorus. We gave that to Greta, and two things happened. She played it for [Ken actor] Ryan Gosling, who liked it so much that he wanted to sing the song himself. The script then also required that the song included an eight-minute-long battle sequence. They shot it with the song on loop, so we later had to write the music for that section.

“We were like ‘OK, what templates do we have for this type of thing?’ We thought of ‘Flash Gordon’ by Queen, and in general the whole multi-tempo,

multi-key milieu of prog rock. We wanted to make a sonically modern version of stuff that we loved, from Meatloaf to ‘Bohemian Rhapsody’ to Yes and Jethro Tull songs, that had multi-phase scene changes in them. That was a lot of

## Andrew Wyatt: “In a weird way, we ended up working like they do in Bollywood films, with directors writing movie scenes to the songs.”

fun. So they shot the battle sequence inspired by us, and we were inspired by what we saw to keep elevating and speeding up the song.”

### Private Language

Wyatt and Ronson wrote and recorded the two songs for the most part at the latter’s Zelig Studios. “We have a level of trust and comfort in working with each other, where we have a language between us, and we know what the better bits are and what to leave out. It’s very fluid.

“With ‘Dance The Night,’ the Picard Brothers did some drums and stuff. I played a Fender Rhodes 73, the one with the speaker, and I played the bass line on the five-string ESP bass that was used for ‘Uptown Funk’, and overdubbed that with the Moog Model D, to give it extra thickness. For vocals we used

Mark’s Neumann CMV563, a great mic, going through a Neve 1073, and the usual Pultec and Tube-Tech CL-1B. We recorded straight to Pro Tools.

“When writing ‘I’m Just Ken’, Mark and I played everything in his studio. I did the drums and he did the bass, and we both played guitars and keyboards. When we realised that the song was going to be in the film, and also when it looked like the film was going to be a huge cultural phenomenon — we had no idea when Mark first took the gig — we decided

to bring in the big guns. So we had Josh Freese come in to play drums, Wolfgang van Halen play rhythm guitar, and Slash on solo guitar. Mark and I can fake it but there’s something that happens when you have musicians come in who have gifts from the gods.”

### Expanding Horizons

At this point, the making of the soundtrack album and the making of the *Barbie* movie score started to influence each other. First of all, with the film team thrilled about ‘Dance The Night’ and ‘I’m Just Ken’, the decision was taken to ask Ronson to oversee the creation of the entire soundtrack songs album. This led to Wyatt and Ronson also co-writing and co-producing the song ‘Pink’, sung by Lizzo, with the involvement of her regular producer Ricky Reed;

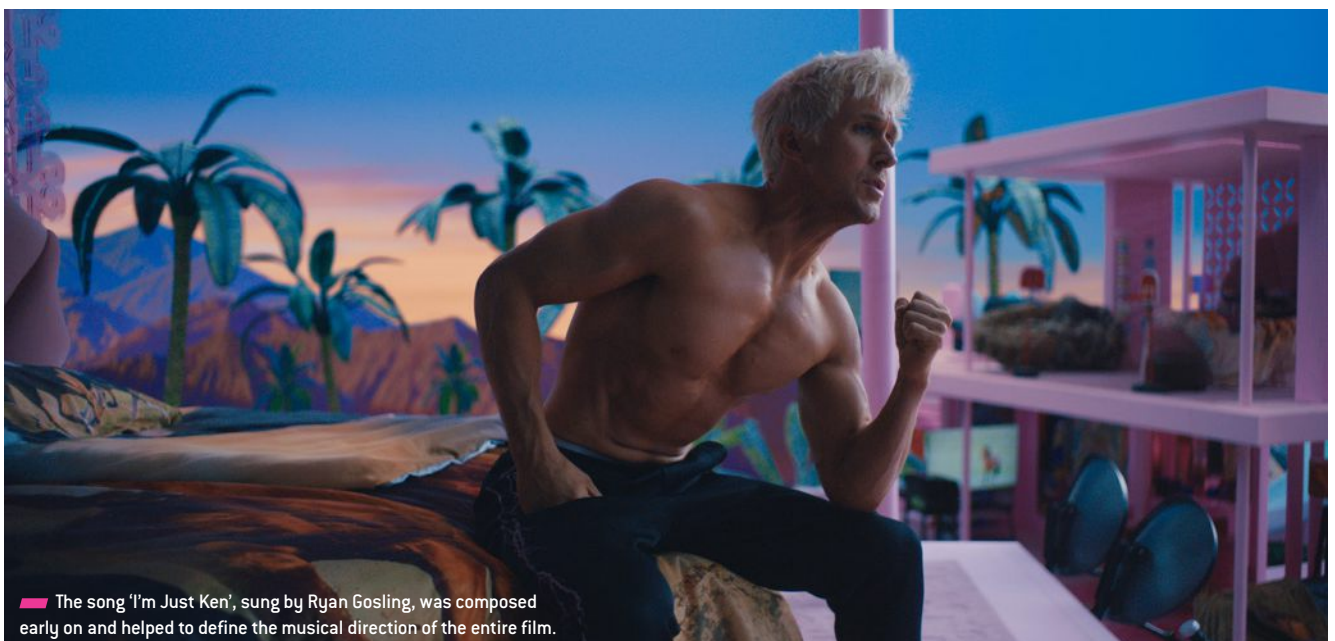

— The song ‘I’m Just Ken’, sung by Ryan Gosling, was composed early on and helped to define the musical direction of the entire film.

»



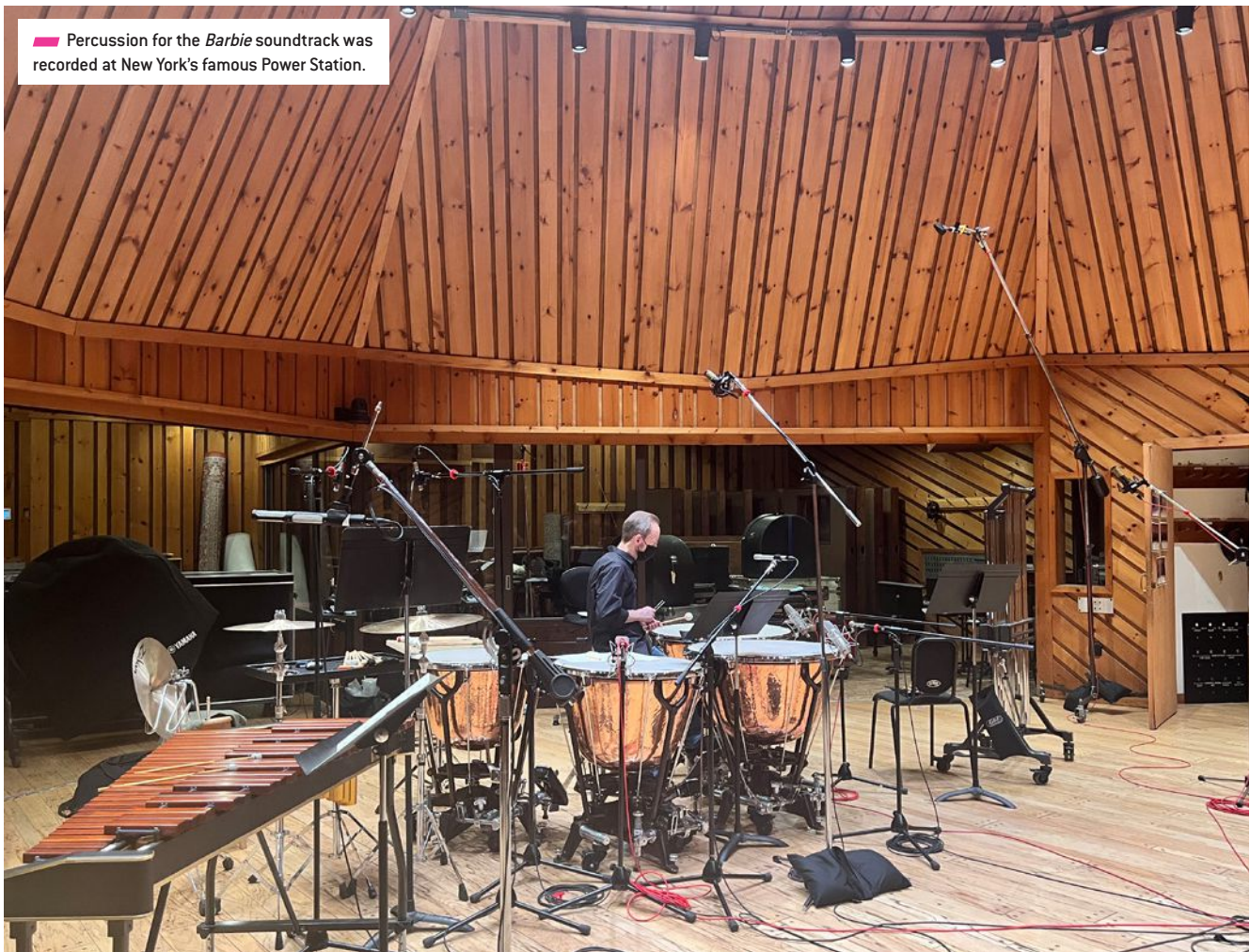

▶ Percussion for the *Barbie* soundtrack was recorded at New York's famous Power Station.

Photo: Alex Venguer / @coostermindstudios

» co-producing the song 'Push', also sung by Gosling; and Ronson co-writing and co-producing the Sam Smith song 'Man I Am', again together with Reed. The other songs on the album were curated by Ronson without his direct involvement.

In addition, the Billie Eilish song, 'What Was I Made For?' was co-written by her and Finneas, and co-produced by Finneas, Wyatt and Ronson. Most of the producers' work consisted of adding orchestration to the piano ballad. "I did the arrangement for that at my studio in Pro Tools using the Vienna Symphonic library stuff," recalls Wyatt.

"The tricky thing was not to add anything that would mess it up, because it's already so beautiful. It was a matter of adding a tiny bit here and there to expand the atmosphere, and putting in a little bit more of a larger dream space, but without it being an overbearing presence in the track. I had way more in my initial arrangement, and after that it was all about take out, take out, take

out, and let the song shine and have this natural feeling."

### Taking Up The Reins

While Ronson and Wyatt were busy with the songs, the score for the *Barbie* movie was being written by French film composer Alexandre Desplat. However, by March 2023 he left the project, and Ronson and Wyatt were asked to step in and write the score instead, with a deadline only a couple of months away. This is where the long days came in.

"It was a crazy amount of work to do in such a short period of time, and because we were new at it, we felt like we had to give every single cue our absolute best. We looked from many different angles and tried many different things, and every time asked each other, 'Are we really making the emotional experience of this film better and richer?' Sometimes it would be something that worked but that didn't really elevate it or make us feel the emotions that we wanted people to feel.

And if we couldn't make ourselves feel it, we couldn't expect others to feel it. We set a very high bar for ourselves, and it took many attempts for us to feel like we got each scene the best that we could."

Their dual role meant Ronson and Wyatt had a unique opportunity to make sure the songs and the score lived in the same sonic world — but, first, they had to work out the exact nature of that sonic world. "We couldn't do a neo-classical or neo-romantic score, because that would have clashed with the visuals too much. Instead, the visuals were screaming '80s synths to us. In the '80s in the US, Barbie was untouchable as the uncontested champion of dolls, so it made sense to be drawing from the '80s aesthetic. Also, a lot of what's big in the pop world right now sounds like early synth music from the '80s. Much of the Weeknd's stuff sounds like a John Carpenter movie! Plus Barbie is occupying a kind of surrealist world with lots of really bright colours that suits these synths.

»



# The Original. Remastered.



## Scarlett. The new generation.

All-new preamps to get the best out of any mic. Massive 120dB dynamic range to hear every detail. Re-engineered Air mode lifts vocals and instruments to the front of the mix.

Auto Gain automatically sets your levels and Clip Safe keeps them in the sweet spot. Plus a huge bundle of software and plugins.





» “So it felt appropriate to use those '80s keyboards, and one of the most important is the Yamaha CS80. We dreamed of having one for about two weeks and then Mark just bought one. We were very excited. I'm very friendly with a lot of plug-in makers, and many do a decent job of recreating analogue synths, but there's still nothing that competes with a Moog bass sound, or a Roland Juno-6 for a pad sound. Our challenge was then to find a zone where these synths could live together with the orchestra. It took a lot of trial and error.

### School Of Scoring

Ronson and Wyatt spent considerable time studying film music by the likes of

John Williams, Nino Rota, Carter Burwell, Elmer Bernstein, and the synth and orchestra music of Maurice Jarre and Thomas Newman. “That's part of the woodshedding. It's like, 'I kind of know what they're doing but let me figure out exactly how they're doing this.' That's the process, to learn new skills and improve your technique. We were trying to up our game. Again it's exploiting your own labour. Also, the whole film is incredibly eclectic, the scriptwriting is eclectic, with pop references, philosophical references, and so on, and it goes from very erudite to very stupid, in a good way, like slapstick. It's a very high-low kind of movie, so we figured let's use classical music, and crazy pop music, and punk

rock. We wanted to have a similarly large range in the film because the script really called for it, and the production design was so wild that you know you're in a world where anything can happen.

“I've studied at a conservatory, so I have a cursory knowledge of orchestral stuff, and Mark and I have each worked with orchestras before. I use the Vienna Symphonic Library, in Pro Tools, because to me it's the classicalist sound. I'm the kind of guy who, if I want to listen to Schubert, I listen to Elisabeth Schwarzkopf. I don't listen to new recordings. The VSL stuff sounds the most dusty, and you have choices like having ribbon microphones in mono only. You can tailor it to give it the feelings that





Photo: Alex Venguer / @coostermindstudios

## Simplifying The Studio

Andrew Wyatt divides his time between LA and New York. “I had a studio full of vintage stuff on my property in LA, including a Scully four-track tape recorder, an MCI 416 board, Ampex 351s reconfigured to be mic pres, and tons of outboard. The gear list was a mile long. I used this setup during tracking sessions with Miley Cyrus, Dua Lipa, Liam Gallagher, Charlie XCX, the Yeah Yeah Yeahs and so on. But then, during the pandemic, I didn’t have an engineer, and while I was recording my new album, everything kept breaking. My Roland Chorus Echo weighed 16kg, and I had to take it out of the rack, and bring it to a place in Venice where it could be fixed. That took two and a half hours. I then had to pick it back up and reinstall it, and it was still not working. I did that three times! Then the 351s started making noises, then something else started making noise, then the transport went wrong on the Scully. I realised that if you don’t have staff that takes care of the gear all the time it’s just too much.

“So I sold everything, except for a few incredible pieces, like my Neumann U47, my modified CMV563, and my Sony C36 microphones. I kept everything that was perfect and had never given me any trouble. I also kept my Roland Juno-6 with the Juno-66 modification. I have one Waldorf Wavetable synth, and a new Prophet 10 by Dave Smith, which is one of the greatest analogue synths ever made. It sounds exactly like the old stuff and it doesn’t break

every 10 days and it stays in tune. Plus I have a new Moog Model D. This is all in my basement in New York City now. I have nothing in LA any more. I have a small UAD Apollo setup next to my piano and a Neumann UM57 and that’s all I need. I’m out of the whole ‘Let’s fix everything every few weeks’ phase of my life! I want stuff that sounds great but works.

“My new album was mostly done in my old studio, but the newer stuff is done in my new studio, so not tape. But it sounds matched in a nice way. I’m nevertheless thinking of buying a refurbishment of a 1971 Nagra IV-S stereo. It costs \$20,000, but it’s like getting a brand new reel-to-reel from Nagra. It means I can bounce to stereo without it taking up a bunch of space in my studio. And it’s like new, so not likely to break.

“My new album is called *Some Day It Won’t Feel Like Dying*. During the pandemic I broke up with my long-term partner, who I thought and hoped was going to be the last person I was ever with. You forget what life was like before. It takes a long time to feel like being single is OK, and not some tragic scenario. At least it did for me. So the whole record is about confronting middle age alone, which is tough, and that sort of icy chill that you get thinking about that, and the coping mechanisms deployed in order to deal with a situation that can feel insurmountable. The plan is for it to be released in February, because I don’t want it to steal the limelight from the up and coming Miike Snow album.”

at the very least wanted to run everything past him, so we knew it was going to work when there were 140 people on the sound stage for the recordings. We didn’t want to have any surprises, and he’s a real pro. It was our first rodeo, but he’s done this a million times.

“So, while we created many of the arrangement ideas and orchestration ideas, he was very important in translating them, and he also added many interesting ideas. He’d add things or take out things that he thought weren’t going to work, and when he was done, he gave things to his transcriber. By this time we had a really good idea of how things were going to sound, which is a wonderful advantage of the way you can work today.”

### Whatever Works

The songs album was mostly mixed by well-known pop mixers like Serban Ghenea, Manny Marroquin, Rob Kinelski and Tom Elmhirst. Elmhirst also mixed most of the score album, apart from the orchestral recordings. Cut at Abbey Road in London and the Manhattan Center in New York, these were mixed by Kirsty

Whalley and Peter Cobbin at their Such Sweet Thunder studio in London.

Both albums have proven to be fundamental to the enormous success of *Barbie*. How does Wyatt look back now on his and Ronson’s achievement? “During the *Barbie* rollout I met director and screenwriter Paul Schrader, who is a living legend in Hollywood, and he said, ‘I love working with first-time scoring composers because they’re trying to solve problems for the first time and in the process they often find innovative or new ways of doing that.’ That rang true for me. We were trying to figure out ways to solve problems and we were pulling from a vast number of sources to inspire us.

“We didn’t know exactly what was going to work. All that really matters is: can you make something that helps the emotional energy travel from creator to audience? That’s the only real parameter. The beauty of what we did is that it seemed to really work. It was very rewarding. We eventually found a vernacular. Every film is different, and we’re already looking forward to doing a new film!” ■■■

For the New York orchestral recordings, engineer Alex Venguer brought in piles of vintage gear to augment the Manhattan Center’s own equipment.

you want. These samples don’t sound commercial to me, which I like.

“So I made mock-ups of the orchestra arrangements in my computer, with Brandon Bost, our engineer, and got it sounding 90 percent of what we wanted. Brandon Bost is really like the Fifth Beatle in this situation because he’s so good at writing in the articulations on the Vienna Symphonic Library, and automating things. This meant that Mark and I could really concentrate on the themes and the orchestration.

“We’d then give the orchestrations to Matt Dunkley. With a film of this size, we





# HUM Audio LAAL

## Mastering Limiter

HUGH ROBJOHNS

Established in 1999 in Poland, the HUM of HUM Audio Devices is an acronym for Human Unhindered Maker, apparently. The company currently offer a small but growing range of products, comprising three ribbon microphones (two active models, one with a one-inch and the other a two-inch ribbon, plus a remote-controlled stereo mic), a mic preamp (also with remote control), an ambitious modular analogue console launched at GearFest UK in the Summer, and the subject of this review, the LAAL, which is a rather unusual mastering limiter. LAAL stands for 'look-ahead analogue limiter', so before diving into the details of the LAAL itself I thought it would be useful to provide a brief overview of analogue look-ahead limiters more generally.

### Delay-line Limiting

One of the inherent problems of all dynamics processing is the accidental

This all-analogue feed-forward limiter has the sort of look-ahead function normally found only in digital devices.

introduction of unwanted distortions as side-effects of modifying a signal's instantaneous dynamics. There are many causes for these distortions, such as non-linearities in the gain reduction circuitry, or the way in which the side-chain time constants relate to the signal's component frequencies. For example, a very fast release time can often result in 'envelope modulation' whereby the amount of gain reduction varies according to the instantaneous amplitude of a low-frequency waveform. Another well-known issue is the way a very fast attack time constant results in misshaped transients, creating clicks or transient distortion.

This last issue is particularly pertinent to protective peak limiters that are designed primarily to prevent transient overshoots from overloading the signal path. Controlling fast peaks inherently needs a very fast response time, but a conventionally fast attack inevitably 'reshapes' the initial transient in a way that often creates audible distortion.

Consequently, a slower compromise must usually be found in standard limiters, balancing absolute transient control with acceptable audible artefacts.

A better way to overcome this problem of transient control is to anticipate an upcoming signal peak and thereby introduce the appropriate amount of gain reduction in advance of the peak's arrival (see Figure 1). In a normal feed-forward limiter, the input signal is split in two, with one part feeding the gain-reduction element (GR) and the other part feeding the side-chain processing (SC). The side-chain can therefore only respond to signal peaks at the same time as they arrive at the gain-reduction element. In order to anticipate the peak, the side-chain needs to become aware of the signal before it reaches the gain-reduction element, and in practical terms that requires the signal to be delayed slightly before it reaches the gain-reduction element, to give the side-chain time to react and reduce the gain before the peak arrives.



In the digital world short delays are very easy to implement, and many advanced DAW limiter plug-ins work in exactly this way, using an approach often called 'look-ahead limiting'. Achieving the appropriate delay in the analogue world is nowhere near as easy — but it's not impossible. In fact, the delay-line limiter concept was first implemented in the analogue domain back in the late 1960s for the critical protective limiters that were necessary in broadcast

## HUM Audio LAAL

£8790

### PROS

- Virtually unique analogue technology in the mastering world.
- Extremely effective and transparent.
- Useful additional functionality.
- Ultra-precise mastering-style I/O level controls and metering.
- Dynamic Transient mode avoids HF dulling side-effect.

### CONS

- Very expensive.
- Unusual threshold calibration not documented in the manual.
- Mirror image controls can take some familiarisation!

### SUMMARY

Delay-line limiters are virtually unheard of in the mastering world due to the complexity of their analogue delay circuitry, yet their inherent benefits are perfectly suited to that role, as the LAAL easily demonstrates.

radio transmitters. If you're interested, one of the first such designs, the BBC AM6/7, is explained in a lovely 1967 BBC Monograph that's available online: [www.bbc.co.uk/rd/publications/bbc\\_monograph\\_70](http://www.bbc.co.uk/rd/publications/bbc_monograph_70).

So now you're wondering how a high-quality, analogue audio delay can possibly be created for the main signal path through the limiter, and the solution adopted in that BBC design (and others) was a chain of 'all-pass' analogue filters. I explained the concept of the all-pass filter in detail in an article about how phaser effects pedals work back in *SOS* August 2021 (<https://sosm.ag/how-phasers-work>). But in case you haven't read that yet, an all-pass filter is essentially a special form of audio equaliser. Normal equalisers are designed to change the signal amplitude at different frequencies and, as a (usually) benign side-effect, the phase response changes too. An all-pass filter is a special case where the frequency-amplitude response remains completely flat and unchanged, but the frequency-phase response is intentionally changed — and a phase shift is effectively the same thing as a very short delay (at a specific frequency). By chaining together a lot of carefully designed all-pass filters, sufficient phase shifts can be created across the entire wanted frequency spectrum to work as a very short analogue delay line. In this context we tend more often to refer to its 'group delay' rather than phase shifts, but it's really the same thing.

In the case of that early BBC AM6/7 design, a chain of 10 second-order all-pass filters were employed, courtesy of a series of custom inductors and numerous capacitors, all of which required a large circuit board! This arrangement created an overall delay of 320 microseconds (0.32ms) for all frequencies up to 16kHz. A third of a millisecond might not sound like much of a delay, but it is sufficient to allow a fast gain-reduction element to wind in the required attenuation in time. Obviously, the use of a delay line in the main audio path means there will be some latency through the device too, but at only 0.32ms

or so it's much less than might be expected from converting to digital and back, and in the context of a mastering or broadcast limiter (which will always be at the end of the signal chain) such a small latency is generally irrelevant.

I casually mentioned the feed-forward limiter topology earlier. Many limiters use a feedback configuration, in which the side-chain input is derived from the output signal (rather than the input) specifically so that it retains absolute control over the output level. That's not possible in a look-ahead limiter, which must always employ a feed-forward arrangement, since the side-chain has to monitor the incoming signal so it can react to transients before they reach the gain-reduction element.

## The LAAL

Physically, the LAAL is a beast of a machine, occupying a 3U rackmounting chassis that extends about 115mm behind the rack ears. It weighs a hefty 9.4kg and, even though it's entirely solid-state, it consumes around 70W of power from its internal linear power supply — this is switchable for 120V/60Hz or 240V/50Hz mains supplies, to which it connects using the usual IEC C14 socket. A fancy shielded mains cable is included with the machine. Aside from the power inlet, other rear-panel connectivity comprises just four XLRs for the electronically balanced left and right inputs and outputs. »

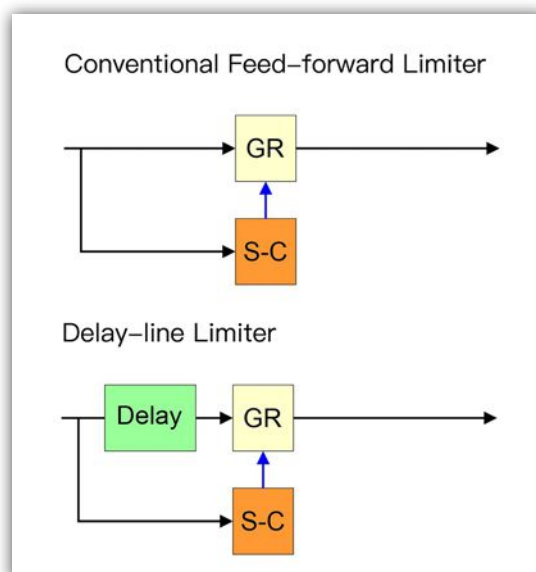

Figure 1: in a delay-line limiter, the main audio path is delayed a tiny amount (<1ms) by a network of all-pass filters, so that the control path 'sees' the signal fleetingly before it arrives at the gain reduction stage.



» Construction is to the highest standards, with a double-shielded toroidal mains transformer bolted to the rear panel, with separate secondaries to power the audio ( $\pm 24V$ ) and control circuitry. The analogue audio is implemented entirely with discrete transistor op-amps, accepting a maximum input level of +24dBu, while the output can provide a whopping +30dBu. Self-noise is claimed to be -102dB (A-weighted), although the best I could acquire was -85dB A-weighted relative to a +4dBu input; I suspect the published figure is referenced to the onset of limiting at +13dBu (see below). THD+N is quoted as 0.026% and my Audio Precision test agreed with that. The analogue delay line introduces just 0.2ms of look-ahead latency.

Somewhat unusually (and, for me, confusingly at first) the LAAL's two sets of operational controls are arranged in a mirror image. HUM chose this layout to ensure perfectly symmetrical internal audio circuit paths, which they claim is important for the unit's precision. Channel matching is claimed to be better than 0.1dB, and the side-chain circuitry is thermally compensated to ensure stability and repeatability regardless of environmental conditions.

In mastering applications, the ability to reset controls precisely is critically important, so every function on the LAAL has either a rotary switch or a button. Each channel features large input and output coarse level controls spanning -10 to +12 dB (in 2dB steps), and these are supplemented with adjacent fine trim

controls covering -1.0 to +1.2 dB (in 0.2dB increments). The release time constant switch presents 2, 5, 10, 20, 50 or 100 ms options, while the attack time is effectively fixed by the delay line duration and is not adjustable.

There are no ratio or threshold controls either, since the former is effectively  $\infty:1$ , and the latter is fixed at +13dBu (see below). Consequently, setting the LAAL up is a case of choosing a release time to suit the material, increasing the input control(s) to push a portion of the signal above the fixed threshold to achieve the desired amount of gain reduction, and then adjusting

**“The Dynamic Transient mode introduces a variable shelving HF boost, with the boost level depending on the amount of gain reduction and the release time setting... and to my ears it works very well indeed.”**

the output control(s) to set the required maximum output level.

Two full-height 40-LED meters bracket the centre panel, with the first (green) meter showing the input signal level, scaled from 0 down to -20 dB. It seems odd for an analogue limiter to have a meter scaled like a digital device, but HUM have done it this way as the top zero point indicates the onset threshold of limiting. The top 3dB of the input meter is marked very finely in 0.2dB steps, then 0.5dB steps down to -6dB (which is the middle of the total range), and 1dB steps thereafter. There's no ability to monitor the output level directly from the LAAL —

but in a mastering suite there will always be an output level meter somewhere!

With both coarse and trim input level controls at their zero marks, an input level of +13.0dBu reaches the top (zero) of the meter, as I mentioned earlier, and any signal level above that causes the limiter to act. So, after the green input meter reaches the top of its scale, any further level increase exceeds the limit threshold and the first red GR light illuminates (from +13.1dBu). More input level causes the red GR meter to descend, covering a 12dB range in 0.2dB increments down to -5.0dB, and 0.5dB steps from there on.

A limiting threshold of +13dBu isn't always what's needed and if, say, the aim was to limit at +8dBu (5dB lower), the input level would simply need to be boosted by 5dB. Setting the coarse input control at +4 and the trim to +1 would achieve that, as would setting the coarse at +6 and Trim at -1. In this way the highest limiting level is +24dBu, and the lowest is -0.2dBu.

A trio of illuminated buttons either side of the centre section engage a Peak Hold function for the gain-reduction meter, activate the Dynamic Transient mode, and introduce an inter-stage transformer into the signal path. The last is claimed to add “warmth and body” to the overall sound, which it does through a gentle increase in odd-harmonic distortion.

The manual is quite vague about the Dynamic Transient mode, simply saying that it “regenerates transients proportionally to the limiting level” and that “it plays a major role in preserving space and details in the sound”. I found



■ The balanced analogue I/O are on XLR connectors.



■ A peep inside reveals the high quality of construction that you'd expect in top-end mastering devices.

the difference very subtle, but I tended to prefer it engaged. Quizzing the designer about how this function works, I was told that the Dynamic Transient mode introduces a variable shelving HF boost, with the boost level depending on the amount of gain reduction and the release time setting. So if the peak level is attenuated by 3dB, the Dynamic Transient function adds 3dB of HF at the same time. The idea is to compensate for a common side-effect of limiting — a tendency to dull the sound slightly — and to my ears it works very well indeed. Apparently, the Dynamic Transient circuitry is quite complex and

#### ALTERNATIVES

The only technologically equivalent current product I'm aware of is the **ADT-Audio U795** module for their V700 system, although I believe it is only available built-to-order. Other mastering limiters at a broadly similar cost include the **Manley SLAM! Mastering Version**, **Shadow Hills Mastering Compressor**, and **Elysia Alpha Compressor**. Another popular mastering dynamics processor that's less expensive is the **Maselec MLA-4**. But although these are all more versatile dynamics processors than the LAAL, none of them offer the delay-line benefits.

took a long time to develop and optimise to preserve headroom.

Located in the very centre of the unit are a few shared functions. The first is the power on/off button, and this device features a 'soft start' to avoid audible thumps through the monitors. On either side are buttons to activate a rotary Stereo Width switch (with six widening positions), and a Detect Link function, which is better known as side-chain linking (and whose purpose is to prevent stereo image instability).

Four further buttons along the bottom are arranged, yet again, in mirror-image pairs, and these activate for each channel a relay hard bypass of the whole unit, or a soft bypass, retaining the stereo width and transformer circuitry while disabling the limiter sections.

#### In Use

The intention behind a look-ahead limiter is to maintain extremely accurate peak control without damaging the initial transients, and the LAAL achieves both very well indeed. I can't fault its performance in these regards. Switching the transformers into circuit gives a slightly fuller and richer low end, while the Stereo Width control provides a useful range of image enhancement, particularly

through the mid and high ranges — low frequencies seem to remain well centred and solid. Even with 5dB of active gain reduction showing almost constantly on the meters, I often found it quite hard to tell if the LAAL was even switched in to my mastering chain without looking — it is that transparent in its operation. The LAAL is also incredibly simple to configure and use — even if the mirror imaged controls took me a while to get used to! The I/O controls and metering allow extremely precise adjustment of the limiting threshold and output level, which is perfect for mastering, of course. So I can easily appreciate why this unit has already become very popular with high-end mastering studios, here in the UK and elsewhere.

Naturally, a limiter of this quality and precision is expensive but, since the LAAL is almost unique in the mastering market (all-analogue delay-line limiters for mastering are beyond rare, and the only other one I'm aware of is made by ADT-Audio to custom order), I think it's fairly priced amongst its comparable peers. ■■■

£ £8790 including VAT.  
 T Sound-Link Pro Audio +44 (0)1869 600 817  
 W www.sound-link.co.uk  
 W www.hum-audio.com



# EastWest Fantasy Orchestra

## Sample Library

EastWest have taken the part of the map marked 'here be dragons' and made it very much their own.

JOHN WALDEN

Back in the July 2021 issue of *SOS*, Dave Stewart reviewed EastWest's impressive Hollywood Orchestra Opus Edition. This is a massive library capable of equally massive results. If your project requires a conventional orchestral sound, short of recording an actual orchestra (and the budget that requires), Hollywood Orchestra is a top-class choice.

However, for composers working on film, TV or game projects that are set in olden times or in fantasy worlds, a conventional (modern) orchestral sound palette might not be quite what's required. EastWest's latest release caters exactly for that need; Hollywood Fantasy Orchestra. Fantasy Orchestra provides five sections — Strings, Brass, Winds, Percussion and Voices — each populated with sample-based sounds designed to capture a more medieval mood.

### EastWest Fantasy Orchestra

**\$995**

#### PROS

- Fabulous collection of virtual sounds that are ideal for the fantasy music genre.
- Opus front end is impressive.
- The powerful Fantasy Orchestrator turns simple chords into a full arrangement with ease.
- Can sound absolutely epic.

#### CONS

- A serious commitment as a one-off purchase.

#### SUMMARY

EastWest have knocked it out the park with Fantasy Orchestra. It's epic in almost every regard.



As with Hollywood Orchestra, the Opus front end (standalone or plug-in) is used to assess these sounds and a library-specific edition of the powerful Orchestrator — suitably titled Fantasy Orchestrator — is also available. All of the instruments have been recorded in the same studio as the Hollywood Orchestra Opus Edition and using the same microphone options so, sonically, you can easily achieve a coherent sound should you wish to combine the two libraries.

The full library comes in at around 145GB and it's available as a one-time purchase or via a ComposerCloud+ subscription. The individual sound sections and Fantasy Orchestrator can also be purchased individually. So, without further ado, let's discard our armour, chuck a log on the open fire, grab a goblet of mead, and explore a modern take on some sounds designed to take us — sonically — into the past.

### Strings Of Olde

For Fantasy Orchestra's string section, EastWest provide ensembles (usually

three instruments) for a number of alternative string instruments. These include the viola da gamba (to fill the role of the more conventional cello), hardanger fiddle (replacing violin/viola), lutes and mountain dulcimers. Two different hurdy gurdy instruments are also included. These instruments all provide the more authentic tones required to capture the style — for example, even a few notes from the lutes or dulcimers are enough to easily place you in that virtual world.

These genre-specific instruments are complemented by small ensembles of 'low strings' (six celli and four basses) and 'high strings' (eight violins and six violas). These sound excellent and are a sensible addition, making it easy to fill out the underscore of a composition, or add some additional battle-ready power, without necessarily needing to source sounds from elsewhere.

Each of these instruments/ensembles is supplied with multiple performance articulations with both single and keyswitchable presets available. The

Opus front end lets you switch between Soft, Classic and Epic versions, each of which employs a different set of microphone positions, reverb and sample layers to produce its distinct sound. Opus does, of course, give you full control over the reverb and microphone options should you wish to tweak the sounds further.

Do I need to say it? Yes, all these instruments sound very good indeed. Don't be deterred by the relatively small ensemble sizes. They allow a wonderful stereo image to be created and, while there are no 'solo' instruments (hurdy gurdy aside), they can easily go from small and intimate to packing a punch. For example, the viola da gamba, a favourite of Baroque music, sounds truly epic when played flat out (it can get wonderfully strident and aggressive) but is also capable of being beautifully sombre when the Soft version is used. As elsewhere within the library, for the shorter articulation systems, MIDI velocity can control playing dynamics while, for the sustained/legato articulations, by default, MIDI CC11 (Expression) is used.

The sounds of each of these instruments will be instantly familiar to fans of fantasy films or video games and, sonically, they are right on target. The

■ The viola da gamba are a highlight of the Strings section and, in Epic mode, can certainly live up to that label.

obvious caveat to make is that having the right sound palette is only part of the equation; it will also help if you can play performances that sound authentic to each instrument. That is, of course, our responsibility rather than that of EastWest, although as we will see later, you can get a considerable helping hand in this regard from Fantasy Orchestrator.

## Horns Of War (And Other Moods)

The same underlying approach can be found in the Fantasy Brass section. In this case, flugelhorns replace trumpets and ensembles of Wagner tubas and alpenhorns take the role of French horns. Each of these instruments is again supplied as an ensemble of three, comes with multiple performance articulations and with Soft, Classic and Epic sound styles. And to fill out those cues that need a full-on powerful brass, a low brass ensemble consisting of three bass trombones, two cimbassos and one tuba is provided.

The dynamics of the whole brass section are very impressive, spanning gentle to majestic with ease (the flugelhorns are great in this role, as are the alpenhorns at the upper end of their register). However, by the time you get into Epic mode, the power becomes more obvious. For that gigantic film (or game) battle scene, combine the Wagner tubas

and the low brass ensemble and your brass is going to have hearts pounding. It gets big, bold, aggressive and raspy... and absolutely magnificent.

## Ethereal Winds

The instrument collection for Fantasy Winds includes pairs of both high and low Irish whistles. These are staples of Celtic music, both ancient and modern, and their melodic impact can add a flavour of magical or mystical in an instant. A pair of Renaissance flutes (a form of wooden recorder) provide a nice breathy sound that is perhaps flute-like if a little less soft. However, if you need to go even more gentle and soft, then the ensemble of four ocarinas provides a beautiful option, especially in the lower half of their register.

The final element is a trio ensemble of Uilleann pipes. I'll cop flack from my Scottish friends, but the Uilleann pipes are like a more expressive (and frankly, more tuneful) version of the (perhaps more familiar) Scottish bagpipes. Uilleann pipes are again a staple of Celtic music, both ancient and modern (check out the work of Davy Spillane or Steafán Hannigan as examples) and if you want to provide a musical signature for a wild landscape or medieval village, this is an easy way to do it. As elsewhere within the library, all the Fantasy Wind instruments are available in Soft, Classic and Epic modes to accommodate the mood your cue requires.

## Percussion Matters

While the Fantasy Orchestra percussion section features some more conventional options such as snare and tom ensembles, the bulk of the choices are more exotic (and suitably traditional) instruments. The heavy artillery is supplied courtesy of ensemble options for gran cassa, large taikos and nagado-daiko. All three demonstrate impressive dynamics and low-end girth. For something less obviously bombastic, and continuing the Celtic theme, there is a very characterful ensemble of three bodhrans, ideal when you need a rhythmic pulse but without the weight provided by the larger drums.

For a slightly different flavour, the ensemble of nagara (from India) and ashiko (from Africa) can go from powerful to crisp and tight; it's an exotic sound that certainly evokes a sense of the cultures they originate from. More unusual is

»





» the ‘nagara rub FX’, a preset based on sounds created by rubbing the drum in various ways. It’s as much sound design as drum; dark and somewhat frightening. Fantasy aside, you could stick these in any horror context and they would work brilliantly to put your audience behind the sofa.

The collection also has a good selection of top-end percussion. The instruments include the relatively small Balinese ceng ceng cymbals for a bright, but relatively short, splash of sound. A small ensemble of crotales cymbals provides the option for some delicate chromatic lines, while your supply of larger metals includes a gong and cymbal ensemble with plenty of impressive low end and splash should you need it. There is also the Orchestral Metallurgy ensemble (large metal objects being struck) and a chromatic orchestral bell ensemble goes from ‘church bell’ up to ‘medium sized clock bell’ should you need it. A goat-nail-based shaker provides a dry, rattle-like option, while the ‘Metal Shaker’ preset provides a somewhat tighter sound, but both are perfect for adding a rhythmic accent. Finally, a North African krakeb does the castanet duties, and their metal construction gives them a very distinctive sound.

### Majestic Vocals

Vocals can play an important role in fantasy-style scores, so it’s great to see a dedicated Voices section included. Across multiple presets, the sounds are divided into two groups. First, there are full male and female choir samples (including presets that combine both) covering a range of different sustained vowel sounds. With Soft, Classic and Epic modes available, as well as dynamics control via CC11, when it comes to full choir ensembles providing either a soft ‘ooo’ to caress your ears, or a ranging ‘ahhh’ as the clouds part and our fallen hero ascends to heaven (OK, you get the idea), these sound very impressive indeed. My only wish-list item might have been for some staccato presets for these choir instruments.

The second element of the Voices section is a number of different solo voice presets provided by the beautiful vocals of Norwegian singer Merethe Soltvedt. The various presets include sustained vowels in both lyrical (more dramatic) and vibrato (for higher energy) styles and separate presets for ‘ah’ and ‘oo’



■ If you need horns to suggest war, Fantasy Orchestra will gladly supply them.

of individual phrases, some short and some long, that can easily be chained together. Finally, there are presets containing a collection of 60 words taken from Tolkien’s Elvish language. No, I don’t

»



■ The instrument choices within the Winds section can add plenty of medieval character.



# JOE ELLIOTT

DEF LEPPARD | LEAD SINGER | 8424 CONSOLE



“Our Engineer Ronan and I wanted a Neve, and we identified the 8424 - which is a magic desk. I have one in my studio here, and Ronan has one in his studio - it works really well.”

 DESIGNED AND CRAFTED IN THE UK BY NEVE® ENGINEERS

 **Neve**



» know what they mean either, so the sung phrases I construct from them (there is a convenient keyswitch-based preset that makes this very easy) may well make very little sense... but they will sound beautiful.

### The Magnum Opus

As with Hollywood Orchestra Opus Edition, all of these Hollywood Fantasy Orchestra sounds are accessed through EastWest's Opus front end. This has continued to evolve and, for me at least, appears to be an efficient and slick platform with a well-organised Browser page. You can use individual instances for each preset or load multiple presets into a single instance and assign each to a specific MIDI channel.

For many users, the Play page may then offer all the sound tweaking you need but, for those wishing to go deeper, the Mix page provides plenty of additional controls and access to a comprehensive set of effects options, including a number of SSL processing emulations. EastWest have a detailed reference manual available for Opus on their website for those that do want to dig in.

In the review of the original Hollywood Orchestra Opus Edition, one element that Dave Stewart was particularly impressed with was the Orchestrator. That engine is adapted here to accommodate the five sections of Fantasy Orchestra but, fundamentally, it operates in the same fashion. This engine has been created for EastWest by Sonuscore who have as impressive track record in designing 'performance engines' that can take even the most basic of MIDI input (a simple sequence of triad-based chords, for example) and, in real time, transform it into a fully-fledged musical arrangement. Fantasy Orchestrator lets you do just that with the sounds from Fantasy Orchestra. And, in use, it is almost magical.

The Orchestrator ships with a huge collection of presets that are divided into three categories; Ensembles, Ostinatos and Scores. The Ensembles provide various instrument groupings (for example, 'Brass Long' or 'Strings And Choir' or 'Full Orchestra Short'), each of which automatically loads the necessary individual sounds into Opus. Each sound has been pre-configured to respond to particular notes within your MIDI chord input, so the instruments automatically arrange themselves as you play. Dynamics is controlled via the mod



■ The Percussion section can do 'big' but, equally, has plenty to offer for more finessed rhythmic parts.

wheel for easy creation of crescendo/decrescendo performances. It's incredibly easy to use but can sound truly epic. You can, of course, swap individual sounds in/out of the presets and change how they respond to the incoming MIDI should you wish.

Things get taken a little further with the Ostinato presets as, in this case,

the majority of the sounds then make use of their individual step sequencers to generate a rhythmic component to their playback. The presets span a wide range of half-note to 16th-note rhythmic options (including triplet choices) and

■ The clever step sequencer system within the Orchestrator is what delivers its magic, and it is fully editable by the user.



Do you speak Elvish? Yes or no, Fantasy Orchestra can sing it for you.

for simple underscore elements to drive a cue along, these presets are incredibly useful.

I commented earlier that having a genre-appropriate orchestra of sounds is only part of the equation if you are trying to create convincing music in the fantasy style. Equally important is the skill to play and combine those instruments in an authentic way. This is where the Scores presets come in and, if you want the maximum wow factor from those few simple MIDI chords, this is where it is at. By the time we get to these Scores presets, the step sequencers associated with many of the instruments have melodic elements assigned to them. The engine very cleverly lets these step sequencers follow the chord changes/voicings in a musical fashion so, as you play, it's almost impossible to generate duff notes. Again, the dynamics can be controlled by the mod wheel and, with just a few chords, your whole Fantasy Orchestra can spring into glorious life.

If you are able to let your monitoring system off the leash for a few minutes, the results are truly a thing to behold; Fantasy Orchestra can take your simple chords and transform them into something epic. Or something intimate, or melancholic, or mysterious, or magical, or majestic, or doom-laden... Because each of the Scores presets is designed with a particular musical mood in mind so, whatever the style of cue you need to create, there is a starting point for you to explore. Add an instrument or two with a suitable top-melodic line and the deal is sealed.

Accomplished composers can, of course, choose to create their compositions without leaning on the Orchestrator, and Fantasy Orchestra provides an excellent palette of sounds to do just that. However, whether you



are just starting out on your journey into composing fantasy-style scores (in which case, this is a brilliant educational tool) or an experienced composer within the genre needing to get some ideas together in double-quick time to hit a deadline, Fantasy Orchestrator is a heck of an assistant. You can create your own presets and, for example, I can imagine this working well if your score returns to particular themes or motifs for certain characters or locations. And the system is MIDI driven; it happily responds to your tempo choices and includes MIDI export to your DAW for further editing or use with other virtual instruments. The whole Orchestrator concept is brilliant. Hats off to Sonuscore and EastWest; it's the very tasty icing on the top of an already impressive cake.

### Bardic Inspiration

Compared to the more conventional palette of EastWest's Hollywood Orchestra, Fantasy Orchestra is perhaps something of a niche product. However, this library represents an absolutely fabulous sound set for composers working in film, TV or video game environments where a score that captures a mediaeval or fantasy sound

— and can place the audience in that ancient world — is required.

Opus provides a very slick front end for all these sounds and, while Fantasy Orchestra is not quite as hefty as Hollywood Orchestra in terms of the total library size, it almost goes without saying that the better the computer host, the smoother the experience is likely to be. That said, the minimum specifications — hard drive space/performance aside — are likely to be easily surpassed by anyone who is able to keep their music production computer reasonably up to date.

No, Fantasy Orchestra is not cheap as a one-off purchase but, for working composers, it's just another reason to

argue that EastWest's ComposerCloud+ subscription offers exceptional value for money. EastWest are also fond of the occasional sale and both one-off and subscription prices can be found with considerable savings if you get your timing right. If you need further convincing before taking the plunge, EastWest have an excellent set of multitrack demos you can audition on their website. Equally, you should also check out Dom Sigalas' YouTube channel, where he has a recent video that walks through composing a full cue using Fantasy Orchestra; it's very impressive.

If composing within this specific musical genre is something you aspire to, then Fantasy Orchestra provides a brilliant one-stop option to help you live out your own musical fantasy. These are big-screen (or big game console) ready sounds, and you will undoubtedly be hearing them in many soundtracks. Fantasy Orchestra is simply excellent. **///**

£ Fantasy Orchestra \$995, individual libraries from \$99, ComposerCloud+ subscription \$19.99 per month/\$199 per year. Prices include VAT.

W [www.soundsonline.com](http://www.soundsonline.com)



# TalkBack

## Galya Bisengalieva

WILLIAM STOKES

**G**alya Bisengalieva is a composer, producer and instrumentalist, whose violin playing features on works by Thom Yorke, Suzanne Ciani and Actress, as well as numerous film soundtracks including *The Matrix Resurrections*. Growing up in the Soviet state of Kazakhstan, her musical upbringing was shaped by a strict classical education and her grandfather's playing of the *dombra*. "We weren't allowed Western influences up until the '90s," she explains.

A scholarship from the Royal Academy of Music brought Bisengalieva to the UK, where she has developed her writing and production techniques alongside her instrumental skills. In 2019, having released two EPs, Bisengalieva set up her own label, Nomad Music Productions. "That was a monumental shift for me," she says. "I self-released those two records and also collaborated with a few amazing artists. That really shifted my thinking: it was not just about performing, but also producing a record from scratch, basically." Bisengalieva's latest solo album *Polygon* explores the story of the Semipalatinsk Test Site in Kazakhstan, and the 456 nuclear tests there that exposed over a million people to radiation.

### At the moment I can't stop listening to

So, it's actually an app! It's an app called Radiooooo. It's like a musical journey in time, across the whole world. You can pick from most countries. And it's made for loads of new discoveries for me. It goes from, like, the 1900s, all the way to the present day. It's amazing. And actually, it's been a way for me to stay connected to Kazakh music because people can upload tracks to it; so I've been listening to a lot of music from the 1970s, a lot of folk music from Kazakhstan. I've been listening to Kazakh artists like Dos-Mukasan, and Roza Rymbaeva, too.

Dos-Mukasan are a band; I think they were quite heavily influenced by the Beatles in the '70s. Roza Rymbaeva is a famous singer, also from the '70s and '80s. She's actually originally from Semipalatinsk, which *Polygon* is based on. Yeah, these people were very prominent during that time. Radiooooo is such a great app. It just feels... communal.

### The project I'm most proud of

I guess it'd be my first EP. It was just such an epic undertaking, also with setting up the label. It represented a transition from being a classical performer and improviser into a composer-producer role, shall we say! It just felt like a big step. A really nice moment was when Actress remixed "Tulpar", and it was so great because we had collaborated together before that. We made a track just called 'Galya Beat'! It was just such a nice place to be in. To have a track of yours being remixed by such a great artist. He's amazing.

### The first thing I look for in a studio

The red Persian carpet. Like, the ones you see everywhere! Why do I feel like studios are always so dark? Maybe because they're often down in the basement? But in seriousness, it's simple: I record mostly at home. Nigel Godrich introduced me to the Soyuz mics that I use now, and they have been very instrumental in my very simple setup. I just need good mics. And I need a positive headspace. I actually finished *Polygon* in Deptford, in Unwound Studios. And that was really nice. There, I guess I would look for the microphones, since the ones I use are pretty great! But I don't need an extravagant setup. I've been part of sessions at Abbey Road, at RAK, all the big studios. But for me, for myself, I just need something very simple. So it mostly takes place at home. I just have a very simple pedal setup with a [DigiTech] Whammy and a [Source Audio] Collider, delay and reverb. I love to start with the acoustic sound of the

violin and then manipulate it, as opposed to going into electronics straight away.

### The person I would consider my mentor

This one is difficult! I've been involved with a lot of collaborations in the past with people I admire, like Pauline Oliveros and Moor Mother, and Darren — Actress — has been a big part of my life. These people have all really inspired me. Pauline Oliveros, meeting her, you get every single feeling that is in her music! She's amazing. We did this rock piece: literally, we were hitting rocks. I still have them! If there was one from Kazakhstan, it would probably have to be my grandparents. Growing up with the sound of the *dombra* playing, and hearing my grandmother singing. I think maybe that's why I gravitate towards taking folk elements into my composition.

### My top tip for a successful session

I guess, for myself, it's to keep it short, and keep it concentrated. I finished my album in December, and I only had about three hours per day to work on it, because I had a baby very recently. So it was at very specific times that I had to work. I had to have a clear goal, and not overstretch myself. And those sessions felt very proactive, because I had those time boundaries in place as I was going into the studio. So going in with a clear goal actually made it possible to finish the album. *Polygon* took me three years. And that's why, this time, at the end it felt so good. I mean, I have had those sessions as well, where you have all the time in the world to create — and that can be very fruitful as well. But at some point you need to say: "This is it!"

### The studio session I wish I'd witnessed

It would be, like, one of Stevie Wonder's early sessions. Or the Beatles: I love going into Abbey Road and just feeling that presence! I mean, with the Beatles, when I was growing up I'm not sure they were even legal — export at that time was



basically not allowed. But it's shaped a big part of my musical tastes. I watched the *Get Back* documentary — it's so great that we've got an insight into that. So I'd probably say the *White Album*.

I just love the way those albums were recorded. The sound world. I can just hear how good the arrangements are. Like, the string playing, I love the reverse tape, all the magical effects, that I suppose they kind of created! So yeah, it's all those innovations, but also the little hidden things that I can hear — certain things in the strings — all those elements. The quality of it, I just find it amazing.

But you know, I just feel so lucky, I've got to work on some of the best projects there are, in my opinion! Some of the best things that have come out recently. I've mentioned some of them already. But the most recent one is Sigur Rós, their latest album, *ÁTTA*, I did some solo violin and then we just toured with them. Hildur Guðnadóttir, on

a soundtrack, working with her has been great. The National, Taylor Swift...

#### **The producer I'd most like to work with**

I think, TOKiMONSTA. she's a Korean-American producer and DJ. She's cool, she's a DJ but she has nice jazz vibes. I like the rhythms she creates. *Lune Rouge*, that was her album. That was quite famous. She would be my pick. I would love to meet her and work with her. Probably do something beats-driven. I love experimenting with beats. Most of the rhythms on all of my recordings are created on the violin. Either plucking or stopping the sound or hitting the wood... I try and find really interesting ways to play it like that. The violin is of course such a melodic instrument: that's what most people envisage, but I like to try to dispel that. So, most of the rhythms are not from percussion, they're from that instrument. It would be cool to get a different

perspective, maybe from a more electronic, eclectic-sounding world.

But also, Missy Elliott. No, Björk! She produces most of her stuff, her sound world is incredible. The arrangements also. I mean, I'm coming from it from a string world. The way she manipulates more traditional sounds and creates them, into a new thing. Yeah, I've been listening to Fossora, her recent album. She's comfortable with experimentation and atonality, and not all big stars are. It's just cool.

#### **The part of music creation I enjoy the most**

I guess it's mainly to do with foreseeing the whole project. And telling a story. I tend to visualise my musical compositions, and they tend to tell a story in some way. I think tackling hard subjects and serious subjects has been a theme, although it wasn't always planned, but I tend to just go there. So that energises me — and it's not just music, it's artwork as well. Like, the photography on *Polygon* is from Philip Hatcher-Moore who worked with National Geographic, and he went to Semipalatinsk and he spent time there and interviewed survivors. And because it's still an ongoing subject, with scientists and researchers, and the people who have been affected by the radiation. There is still so much work to do, because there has been a lot of impact on people's health in the area. Even though they've closed the site, that doesn't mean that it's finished. I like to tell those stories, because they're not very well known in the West. I like to try and shine a light on that.

#### **The advice I'd give myself of 10 years ago**

My advice is to do with my classical history, because I was primarily taught to interpret other people's music, to honour and be subservient to that. In the classical world, it's so serious. Composers and instrumentalists are really separated in that world. And I have come out from that and gone into all different areas. I love the genre-less music world. I think music just has to be good in its content, and that's something you can find anywhere. To have that freedom and to have your own voice. I think that's really important. And I wish I had started that journey sooner. It all came from improvisation, collaboration, and gradually became composing and producing. So that's been a slow journey. But I probably would tell myself to do it sooner. I mean, if you're philosophical about it, then you can just think: This is the amount of time it took. And that's OK. ■■■

Photo: Nico Vioroli



MARK GORDON

Conceived 10 years ago by South African Guy Jackson as a DIY project, on the back of a salad bowl in a kitchen, and initially funded by an Indiegogo crowdfunding campaign, the Lumen digital handpan has been a long time coming.

If you're not already familiar with the handpan as an acoustic instrument (see the 'Handpan History' box), the Lumen probably looks like a particularly odd proposition. With its dome-shaped shell and nine pads, it has been designed to emulate its acoustic counterpart both physically and sonically. A built-in speaker and battery allows the instrument to be played anywhere without additional power or amplification but, unlike an acoustic handpan, you can change instruments, keys, scales and volume on the fly. MIDI and USB connectivity take the Lumen into the digital domain for easy integration into your studio setup. I'm not sure if the world has been waiting for a digital handpan, but as a player myself, I was intrigued to see how it stacked up as an electronic version of one of the most unique percussion instruments around.

### Ring Of Confidence

The Lumen ships in a padded, hard-shell backpack with a small pocket on its side to carry the power supply. This not only looks fantastic but protects it extremely well, and is ideally suited to the unique

## Lumen Handpan

£1390

### PROS

- Comes in a great backpack.
- Well built.
- Excellent-sounding samples.
- Unlimited scales and keys.
- Built-in speaker that sounds good.
- Long-life internal battery.

### CONS

- 4GB storage too small.
- Shell cannot be 'played'.
- Control panel initially tricky to navigate.
- No on/off switch.

### SUMMARY

The Lumen takes a unique acoustic instrument into the digital age and is beautifully presented and well implemented. It's a refreshing newcomer to the digital percussion scene.



# Lumen Handpan

## Percussion Instrument

We get hands-on with a unique percussive instrument.

nature of the product. The instrument itself is around 19 inches across — a little smaller than most of the acoustic handpans I have encountered. The upper surface also has less of a pronounced dome than a regular handpan, which further emphasises its compact look and feel.

The shell is made from spun aluminium and has eight FSR (Force Sensitive Resistor) Thermal Poly Rubber pads evenly distributed around it, with a ninth pad in the centre. The pads each have their own dedicated signal processors and feature five pressure-sensitive zones that detect where you strike the pad, as well as the physical pressure you apply.

All functions of the Lumen are controlled via the central control panel, a unique touch interface that comprises a two-inch-wide, hard-plastic ring surrounding the centre pad. The inner part of the ring has a touch-sensitive groove that runs almost all the way round, with a small gap at the point where it faces the

player. Pushing on the outer part of the ring with a single, double or long press selects the menu, and running your finger around the grooved section changes the selection or parameter value. A ring of bright blue LEDs mirrors your moves.

It does take time to get used to this innovative way of controlling the Lumen, but after a while it becomes second nature, so you can move around the various menus quickly and, more importantly, without having to stop playing.

One of the big differences between the Lumen and other percussion controllers is the inclusion of a 30-watt speaker mounted inside the unit, which (in conjunction with a large-capacity, 10800mAh onboard battery with a quoted playing time of six hours) enables it to be played as a standalone instrument. A perforated grille runs around the outer edge of the unit, giving full 360-degree sound coverage with not inconsiderable volume — certainly comparable to

an acoustic handpan — and a very acceptable tone.

The underside of the Lumen is similarly dome shaped, with a slightly deeper curve that allows it to sit very comfortably on your lap. At the very base of the unit, in the area that would occupy the soundhole on an acoustic handpan, is where the audio and MIDI connections are located. Connectivity is limited to a single MIDI output port, quarter-inch stereo jack output, and a USB port that supports both MIDI in and out (to and from your DAW). The last can also be used to load new sounds and update firmware by way of a connection to a Mac or PC. There is also a 12.5V DC PSU connector for charging the onboard batteries but, interestingly, no on/off switch.

### Press To Play

After turning on the Lumen, via a long push of the outer control ring, the built-in sounds take a second or two to load and you're ready to play. The unit ships with four instruments pre-loaded: a first-generation PANArt Hang; a Hang Mk2; a Pantheon Steel Halo; and a Balinese bamboo percussion instrument called a Tingklik. A fifth instrument, the Halo Sub Voyage, is also included as part of the package, but all instruments except the Tingklik are over 1GB in size, meaning that the 4GB internal memory can only accommodate up to four of them.

Library management is handled via the straightforward Lumen Library program, which also handles firmware updates and sound library purchases. Lumen Library makes it simple to swap out sounds,

although loading in a 1.3GB handpan does take a good few minutes.

All the sounds have been professionally sampled by Soniccouture, who have partnered with Lumen to create both the internal sounds and additional libraries that can be purchased from the Lumen website.

Each instrument contains 1350 unique samples divided into various velocity layers, with at least three round-robin samples for each of the velocity layers and at least 10 velocity layers. The five pressure-sensitive zones on each pad enable the Lumen to mimic an acoustic handpan, by assigning five different characters of samples to each pad: fundamental, vertical overtone, horizontal overtone, second harmonic and third harmonic, the last produced by holding a pad and striking a parallel edge, exactly as you would on an acoustic instrument.

Further enhancements can be achieved by adjusting the velocity curves to match your playing style, and by changing the aftertouch, brightness and expression values, which affect the level of dampening when pressure is applied to a pad.

All the above facilitates very realistic and expressive playing, using techniques that are familiar to an acoustic handpan player. However, as you might expect with something as tactile as a handpan, there are a number of concessions that need to be made to the fact that the Lumen is an electronic instrument. The pads are certainly responsive and dynamic, and the samples sound realistic, but it isn't

possible to get exactly the same subtleties of touch you would from an acoustic instrument.

The other glaring omission for me is that there is no sound attached to the actual shell. The handpan is as much a rhythmical percussion instrument as it is a tuned one, and much of its signature sound is achieved by thumping, hitting or tapping the shell, something that is sadly missing from the Lumen's box of tricks.

### A Flying Saucer Full Of Secrets

Acoustic handpans are not chromatic instruments, meaning that they can't play every note possible, like a piano or a guitar, but instead are bound to the notes of a single musical scale, like a harmonica (although that's probably where the similarity between those two instruments ends!). Consequently, you potentially need a different handpan for every key you want to play in, which of course isn't practical. Handpan scales are also a complex subject, as they often lie somewhere between full diatonic scales and extended chords. Each scale has a specific sound or emotion, which is why the scales are given odd names like Hijaz, Kurd, SaByeD and Celtic.

This is where the Lumen comes into its own, with the ability to instantly choose from a huge range of built-in scales and keys at the touch of a button. Two presses of the outer control ring brings up the Key menu, where you can scroll up or down in half steps, with most instruments offering a key range from B2 to C6. Three presses takes you to the Scale menu, where you can scroll alphabetically through the 16 available scales that give each handpan its unique character, from Agean through to Raga Desh and Pygmy. You can even create and name your own unique scales, as there are always new ones to discover out there in the world of acoustic handpans.

### Technology Meets Art

Although the inclusion of the internal speaker and battery suggests the Lumen is geared to self-contained live performance, the stereo audio output, MIDI socket and USB port also enable it to integrate with other MIDI and computer-based equipment in a studio setting.

Connecting the Lumen to a Mac via USB required no additional drivers and it was immediately 'seen' by my DAW. The USB connection provides MIDI



■ The rear — or under — panel includes a MIDI out port, quarter-inch audio output, a socket for the external PSU and a USB-B port for charging and interfacing with a computer.





» communication in both directions, so you can record your performance directly into your DAW and have it played back from the Lumen, complete with all performance articulations and nuances.

Each pad transmits on its own MIDI channel, and each of the five pad zones (along with the vertical and horizontal harmonics) are transmitted as patch changes — when you strike a different area of the pad, a patch change is recorded by your DAW, along with the note data. This enables the Lumen to select the correct zone internally when you play back the MIDI performance.

As you apply pressure to a pad, aftertouch is transmitted, along with MIDI CCs 74 and 11, controlling brightness and expression levels which, again, are

■ All the Lumen's functions are addressed with a grooved ring around the central pad, the LEDs providing feedback.

reinterpreted by the Lumen on playback. Being able to record, edit and play back MIDI performances is a great feature, and opens up the potential to use a Lumen as a controller, although you would need some scripting to fully exploit the patch-change data if you were using it with other virtual instruments.

### Conclusion

I enjoyed playing the Lumen, a lot. It feels solid and well built, the pads are responsive, and the sampled sounds are excellent. Having a built-in speaker (that actually sounds very good!) and a long-lasting battery sets it apart from almost every other electronic percussion device I can think of, enabling it to work perfectly for busking, a favourite pursuit of acoustic players. The included backpack adds to the portability and essence of the instrument.

### Handpan History

The handpan originated in Switzerland, where PANArt, a company with history in traditional steel drums, conceived and built a unique instrument they named the Hang. The Hang quickly gained a cult following among musicians and music lovers, who were drawn to its haunting sound. However, due to the high demand and limited production capabilities of PANArt, the Hang was notoriously difficult to obtain, and prices for used instruments soared. PANArt even introduced a policy that potential customers who wanted to purchase the instrument had to present a handwritten letter explaining why they needed it!

Further accentuating the feeling of value, mystique and elusiveness, PANArt stopped producing the Hang in 2013. As a result, various versions of the instrument began to spring up in Europe and the United States, each with their own unique designs, tunings and finishes, but for legal reasons these were referred to as Handpans rather than Hang or Hangdrums. Currently there are over 100 manufacturers of Handpans worldwide, with some makers focusing on recreating the sound of the original Hang, while others are more experimental and create instruments with a wider range of notes and tones. As with any instrument, quality is paramount and, whilst it is possible to buy a handpan for under £500, most high-end products cost upward of £1200.



The advantage of having multiple scales and keys available at the touch of a button is very appealing, as is having access to expertly sampled versions of rare and iconic handpans. The inclusion of MIDI support is also a nice feature, something that was a big miss on the similarly esoteric Wavedrum from Korg, and extends the Lumen's usability into the studio and recording environment. On the down side, not being able to include the contribution of the shell in your performance is disappointing, particularly if you (or Lumen) are expecting this to be a serious alternative to playing an acoustic handpan.

This is definitely a niche product and I'm unsure how appealing it would be to the casual observer. However, that's not where it's aimed, and with a cost similar to that of a mid-range to high-end acoustic instrument, the Lumen's flexibility and functionality make it an interesting alternative to, if not a perfect replacement for, an acoustic handpan. ■■■

£ £1390 including VAT.  
W [www.lumenhandpan.com](http://www.lumenhandpan.com)

# MASSIVE SOUND. NOW IN TWO SIZES.

EFFORTLESSLY VERSATILE | REAL WARMTH AND CHARACTER

*"The 3rd Wave might be my favorite synth released in the last 10 years"*  
- Rory Dow, Sound on Sound

NOW WITH  
**PROPHET VS  
WAVETABLES!**



24 voices · 3 osc per voice · 4 multi-parts · dual analog & digital filters

**NEW!**  
• FREE-RUNNING OSCS  
• POLY UNISON  
• LO-FI WAVETABLE  
IMPORT



4 envelopes & 4 LFOs · built-in wavemaker · virtual analog oscs · knob per function



**GROOVE**  
SYNTHESIS  
groovesynthesis.com

**3<sup>RD</sup> WAVE**  
ADVANCED WAVETABLE SYNTH







# Linux Audio

## Is Linux A Real Option For Music?

On paper, Linux has many advantages over macOS and Windows. How easy is it to get started, and how far will it take you?

KAREN DOWN

The question was innocent enough. “Can you help me put together an affordable recording setup for my studio?” Then came the kicker. “Can we use Linux?” Cue eye roll and a flashback to 20 years ago, where I am listening to a friend extol the virtues of Linux Audio whilst glossing over the missing features in the DAWs available at the time, the lack of supported audio hardware and functional plug-ins, and the regular need to resort to using the command line to make anything function.

In my own experience of professional recording studios, they’ve always been equipped with a Mac or a Windows PC, and nearly always running Pro Tools. I had not considered alternatives. For me, Linux

seemed too complicated and ‘unformed’. I worried that DAWs used in most commercial studios around the world are not supported in Linux — this includes Pro Tools and Logic Pro — and that hardware such as audio interfaces and controllers might lack the necessary drivers. I was also concerned that by not offering a Windows- or macOS-based solution, my friend’s ability to create and find work may be impacted. But as my friend had a preference for the OS, I figured a little research into the subject couldn’t hurt.

### Starting Points

Before embarking on this project, one of the first questions that crossed my mind was: who is creating music on a PC running Linux? Answers include musicians and audio enthusiasts, people

with financial constraints looking for a cost-effective solution, and studios looking to run a second workstation as an alternative to their main system, to name a few. There are also people ideologically opposed to subscription models or dependency on a single manufacturer's ecosystem. This was not something I would have thought to consider — until now.

Luckily, the host hardware was already decided on and there was no need to purchase a new PC. Linux will happily run on low-spec hardware, which presented the opportunity to repurpose an older PC in the studio, potentially helping to reduce electronic waste. For reference, the host was a Dell Optiplex 3020M Small Form Factor PC (normally available on eBay) using an Intel Core i3 CPU clocked at 3.1GHz with 4GB RAM, with built-in Intel graphics and sound.

Next, some research was needed on the preferred version of the OS. I was aware that Linux is predominantly known for its stability, performance, and the level of security it brings to servers, supercomputers and smartphones. But what about audio?

The Linux audio ecosystem emerged through the 1990s. Developers, musicians and enthusiasts worked together to create an open-source platform for audio production. Linux kernel developers, led by Linus Torvalds, worked on providing the groundwork for audio support within the kernel. The Advanced Linux Sound Architecture (ALSA) project, initiated by Jaroslav Kysela, developed essential audio drivers, libraries and utilities that formed the foundation for Linux Audio. An audio framework was being created. With the arrival of Ardour, an open-source digital audio workstation (DAW), the development of the Jack

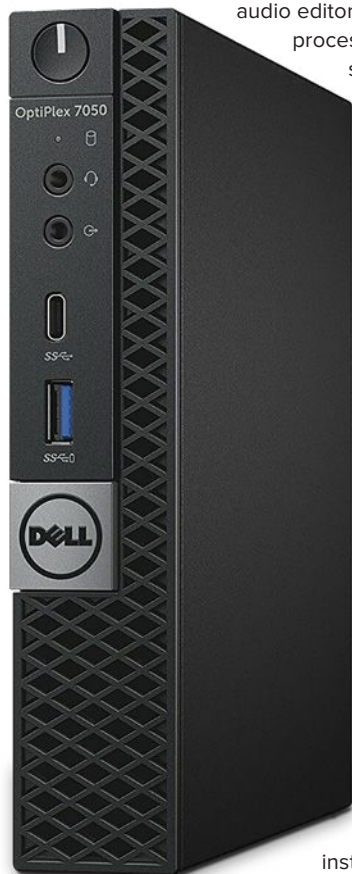

■ One of the big plus points of Linux is its efficiency, which allows it to run well even on hardware that would be underpowered or outdated for Windows.



■ Bitwig Studio is one of an increasing number of music applications that is fully cross-platform, supporting Linux as well as macOS and Windows.

Audio Connection Kit (JACK) that allows real-time, low-latency audio connections between applications, and the continuing work of the Linux Audio community on developing and improving the platform (for example with PipeWire), there is now a wide range of audio production and processing tools built to run on the Linux OS. These tools include DAWs, audio editors, synthesizers, effects processors, audio routing systems, and a wide

range of plug-ins. But would this be enough to provide a viable solution for my friend?

### Which Distribution?

There are many, many versions of Linux: RedHat, Ubuntu, Debian, Fedora, to name a few. So, the first task was to decide on a Linux distribution. I chose Ubuntu, for its track record of stability and user friendliness to the desktop user. Linux's open and modular architecture empowers users to tailor the environment to meet their specific needs, but although I had the option of

installing Ubuntu 22.04 LTS

and selecting the applications relevant to my requirements during the install process, my preference was to use a distribution where the audio-related software and drivers were pre-selected for install.

I decided on Ubuntu Studio, which has a wealth of production tools covering audio (including Ardour and Jack), graphics, video, photography and publishing. Ubuntu Studio is Free and Open Source Software (FOSS), which means it is free to download and use. Updates are released every six months, with a long-term release (LTS) version released every two years if you prefer to stick with your current OS version, only installing security updates as required. For those who are interested, Ubuntu Studio 22.04 LTS is based on Ubuntu 22.04 LTS "Jammy Jellyfish".

After downloading the ISO image from the Ubuntu Studio website, I used an application called Unetbootin to create a USB installer. This creates a bootable thumb drive from which you install the OS: simply plug the USB drive in, power up the PC and follow the on-screen instructions.

### Music Software

As previously mentioned, neither Pro Tools nor Logic Pro is an option on Linux. But although the range of DAWs, creative tools and sequencers available for Linux might not be as wide as on operating systems like Windows or macOS, there are several noteworthy options to consider: >>





■ Ardour is a long-established open-source multitrack recording and mixing package that is the basis of Harrison Mixbus.

“There is a certain amount of understandable inertia amongst manufacturers when it comes to Linux drivers. Without a large existing user base the investment is not deemed financially viable – but without drivers the user base cannot grow.”

- » • **Reaper** is the same program that is available for other operating systems, providing you with multitrack audio and MIDI recording, editing, processing, mixing and mastering tools.
- **Bitwig Studio** is also fully cross-platform, and is designed to be an instrument for live performances as well as a tool for composing, recording, arranging, mixing and mastering.
- **Waveform Free** by Tracktion is a free, fully featured DAW for Linux, Windows and macOS, with unlimited audio and MIDI tracks. It has a user-friendly interface and is suitable for beginners and intermediate users.
- **Qtractor** is a multitrack audio and MIDI sequencer.
- **Rosegarden** is an audio and MIDI sequencer, score writer and musical composition and editing tool.
- **Ardour** is a cross-platform, open-source DAW that offers advanced audio and MIDI recording, editing, mixing and mastering capabilities.
- **Harrison Mixbus** is based on Ardour but tailored for mixing and

mastering tasks, with a professional mixing console interface.

- **Renoise** is another cross-platform music-creation application. With a design developed from the 'tracker' software of the '90s, it lets you record, compose, edit, process and render production-quality audio, and has a wide range of built-in audio processors.

- **Audacity** is an easy-to-use multitrack audio editor.
- **Musescore 4** is a free, cross-platform, open-source composition app that lets you create sheet music.

Note, though, that the availability and compatibility of DAWs on Linux can vary, depending on your specific distribution and hardware setup.

Even though Ardour is installed with Ubuntu Studio, my friend had been using Reaper for years, and wanted this to be installed too. I downloaded and extracted the Linux install package relevant to my host's hardware from the Reaper website. The package contained the software, a Readme file, and an installation script. After reading the Readme file and some quick research on how to run the installation script from a terminal, along with what options to select during the process, the install was complete. Reaper now appeared in the PC's Application menu. I also installed the optional ReaPack and SWS Extensions.

### The Audio Interface

In the past, this is where things used to be a little tricky. The primary obstacle when using a Linux machine for something that requires external hardware, such as audio interfaces, is driver support. For a piece of hardware to work with an operating system (OS), a driver needs to be written that tells the OS how to communicate with the hardware. Unfortunately, developing drivers consumes a lot of time and development resources. This means that it costs money to develop drivers, with an ongoing investment in testing and support necessary. Consequently, there is



■ Reaper is one of the most powerful DAWs around, and runs well on Linux.

a certain amount of understandable inertia amongst manufacturers when it comes to Linux drivers. Without a large existing user base the investment is not deemed financially viable — but without drivers the user base cannot grow. There appears to be little sign of this position changing.

Knowing this, I was concerned about whether I could find manufacturers who had written Linux drivers for their audio interfaces, or whether I would be reliant on a developer in the Linux community to have written a driver I could use. Luckily, there is a solution today. USB Audio Class 2.0 compliant interfaces have become very common. This is a universal standard that is supported at the OS level, meaning compatible interfaces will work out of the box on macOS, iOS and Linux (they will work for general-purpose audio on Windows, too, but you'll need a separate ASIO driver to use them with most music software).

It is worth bearing in mind, though, that many manufacturers also provide additional software to help with the interface's configuration and keep their firmware up to date. If your interface has an internal digital mixer to handle low-latency monitoring, for example, this will typically be controlled using a bespoke macOS or Windows app. Since most manufacturers don't offer Linux versions of their additional software, you will need to do some research to find out whether your interface will retain its functionality if you adopt a Linux-based solution, and/or look for guidance from the Linux audio community. If your interface does not require a software app to access functions, and uses buttons and switches to make a selection, you have a 'plug and play' solution. This is the case with many small desktop interfaces, and for this project I used a Behringer U-Phoria UMC22, which does not use a control app.

## Plug-ins

The news was more positive on the plug-in front. There are now more developers designing instrument and effect plug-ins for use natively on Linux. Companies such as Auburn Sounds, Audio Damage and Applied Computer Music Technologies Ltd, to name but a few, provide a selection of plug-ins in formats such as LV2, CLAP and VST. My friend also asked me if it was possible to install some Windows VST plug-ins

## Linux Audio: For And Against

If you're considering Linux as an option for your own musical endeavours, what are the main pros and cons?

### For

- **Stability and reliability:** Linux's reputation for stability is particularly welcome in the audio realm. It offers an environment where audio professionals can work with confidence.
- **Customisability:** Linux's open and modular architecture empowers users to tailor their audio setup precisely to their needs, be they lightweight home studios or complex professional environments.
- **Real-time audio processing:** Linux excels in real-time audio processing, making it ideal for live performances, electronic music production, and any situation where low latency is critical.
- **Open-source collaboration:** The heart of Linux Audio beats with open source. A global community of developers and artists collaborates to continually improve existing tools and create new ones.
- **Professional-grade software:** Linux Audio now offers an increasingly impressive suite of software, from DAWs like Ardour, Reaper and Bitwig Studio to an array of synthesis and audio processing tools that rival their proprietary counterparts.
- **Community values:** The Linux Audio community is renowned for its inclusivity and willingness to help. Supportive forums, blogs and social groups provide guidance and assistance for users at all levels of expertise.
- **Environmental sustainability:** Linux's efficiency allows it to run on older hardware, extending the lifespan of equipment and reducing electronic waste. It aligns with eco-friendly principles in a world where sustainability is increasingly vital.



### Against

- **Limited commercial software support:** Some of the most popular commercial music production software, including DAWs such as Pro Tools and Logic Pro X, is not available for Linux. If you heavily rely on these specific tools, switching to Linux may not be practical.
- **Hardware compatibility:** While Linux audio drivers have improved significantly, there can still be issues with hardware compatibility, especially for specialised audio interfaces, external audio gear and MIDI controllers. Ensuring that your hardware works seamlessly under Linux can be a challenging task.
- **Plug-in compatibility:** Linux may not support all the plug-ins available for Windows and macOS. While there are workarounds like using compatibility layers (Wine), and there are native Linux plug-ins (LV2 and CLAP), the selection might be more limited compared to other platforms.
- **Learning curve:** Transitioning to Linux can be a steep learning curve for users who are accustomed to Windows or macOS. The different software installation methods and terminal-based commands may be intimidating for some users.
- **Industry expectations:** In professional studio environments, where other software and hardware is prevalent, Linux may not be the preferred choice due to potential compatibility and support issues.
- **Workflow familiarity:** Users who are deeply entrenched in a particular operating system and software ecosystem may find it challenging to adapt to Linux and its associated tools. Familiarity and workflow efficiency can be significant factors in choosing an operating system.
- **Lack of support:** While the Linux community is generally helpful, support and troubleshooting can sometimes be more challenging for Linux audio setups, especially for users with unique hardware configurations or software requirements.

onto the Linux PC, and the answer is yes. There are several applications that facilitate this, including Wine, Carla and Yabridge. (Note, though, that those plug-ins probably won't be officially supported on Linux.)

With a little effort and some research, the project was successfully completed, and despite my initial reservations, I was pleasantly surprised at the ease with which the project came together. But I recognise that whilst the strides made by Linux Audio are impressive, challenges persist. The demand for standardised driver support, greater hardware compatibility and control software for audio hardware remains, but with

important technologies such as PipeWire on the horizon it's clear that Linux Audio is evolving rapidly.

Ultimately, the decision to use Linux for audio production depends on individual needs, preferences, and the specific requirements of your workflow. While Linux offers many advantages, it may not be the best fit for everyone, particularly those heavily reliant on commercial software, specific hardware, or certain established workflows. But it's a viable solution that is capable of supporting music creation, recording and mixing work to a high level, whether as a cost-effective setup or as an alternative to mainstream production tools. **///**



# Universal Audio OX Stomp

## Dynamic Guitar Speaker Modeller

The dynamic speaker and mic modelling of UA's OX amp-top box is now available in a compact pedal format.



DAVE LOCKWOOD

The OX Stomp takes the dynamic speaker modelling of UA's OX amp-top dummy-load, attenuator and speaker simulator and puts it into what's now a familiar UA six-knob, double-footswitch enclosure. Just to be clear, though, this is not an OX somehow miraculously made smaller: there's no dummy load, so you can't plug the speaker output of an amplifier into it. This is a line-level (or below) device, designed to accept the output of a preamp or guitar-amp simulator pedal. Don't UA make some of those, with OX-derived dynamic speaker simulation already onboard, you might be thinking? You'd be right, of course, and very good-sounding they are, in my opinion, although the OX Stomp's wider range of cabs and miking choices offer a lot more flexibility than the onboard choices of the UA amp pedals. There are plenty more really useful applications for this

little box, though: most obviously, you can put it after a dummy load/speaker attenuator, with due attention to signal levels, and enjoy most of the functionality of the full-size OX. You can feed it the output of an 'amp-in-a-box' pedal, but preferably one that replicates an output stage rather than just a preamp. And, finally, you can use it with amp-modelling devices from other manufacturers, many of which may benefit from a more sophisticated and detailed speaker-sim process, especially those from before the era of really good IR-based (impulse response) speaker simulation.

Guitar-speaker IRs are, in effect, just a very detailed frequency response curve derived from a digital recording of a guitar speaker that can subsequently be imposed on the sound of a guitar amp or simulation, and their widespread adoption has had a transformative effect on the usefulness of direct-recording devices for guitars. The speaker simulation in UA's original OX product, however, is not

IR-based, but uses a real-time modelling process that allows it to respond dynamically to varying input signals, replicating the behaviour of real speakers with more detail and accuracy than the static 'snapshot' of an IR.

### Making Connections

Like all the larger format UAFX pedals, the OX Stomp has stereo I/O on unbalanced quarter-inch TS (tip-sleeve) jacks, so stereo inputs can be maintained in stereo, whilst a mono input can benefit from the onboard room simulation in either stereo or mono. Recognising that users may want to employ guitar pedals, not just true line-level devices, as a source, there's plenty of range in the internal operating level; you just need to be prepared to turn up the output control a long way with lower-level signals. There's no level metering on the pedal or in the app, so I just used the position of the output knob when feeding a line input at unity gain as a guide: if I was turning it

below halfway to get a sensible externally metered level, there was probably too much going in. In theory, I guess the input level should make a difference to the 'dynamic speaker modelling', but provided that I wasn't too far to either extreme it all just seemed to work as expected. As usual, there's a USB-C port for registration and firmware updates only, so no MIDI or digital I/O, and you'll need to source your own 9V DC external power supply with a current capacity of at least 400mA.

Like the OX amp-top box, the OX Stomp has a limited number of physical controls on board, with much deeper, detailed control and editing available via the UAFX Control app, but it does still include all the virtual speaker cabinets, microphones and effects of the original unit. Physical controls consist of a level knob for each of the two virtual close mics, plus another (stereo or mono) for the room miking setup, Speaker Drive amount, simulating speaker condition, and an overall output level. In addition, a three-way switch for each virtual mic allows you to choose Dynamic, Condenser or Ribbon as the mic type.

The OX Stomp is built around the concept of the Rig: a complete setup of virtual speaker cab, two mics, room ambience and effects that can be stored as a preset and activated via the footswitches or the UAFX Control app. The Rig knob in the centre of the pedal selects any one of the six presets currently loaded into the pedal as the 'active Rig'. Given that the OX Stomp has neither motorised pots nor virtual, LED-ring pots, it will be apparent that the knobs and switches won't always match the sound of the preset. In fact, they almost never will unless all your presets are basically the same or you've just saved the current setup, which you can do either by pressing and holding the active Rig footswitch until the LED flashes, or within the UAFX Control app.

Rigs saved via the footswitch retain their edits in the pedal itself, but don't get added to the

app's user library until you also save them in the app; your edited version will still be there in that position on the Rig dial even if you have powered down the pedal. You can subsequently find your temporarily edited Rig in the app because it will have an Edited legend, highlighted in brown, beside it in the list. As-yet-unsaved edits made in the app rather than the pedal get highlighted in red. Easy temporary saving seems like it could be really useful in a live performance situation where you might just want to tweak and save the level of a preset rather than doing any deep editing, which you can do without having to involve the app.

## Control App

The UAFX Control app is where you have access to the full line-up of cabs, mics and effects. Tap the Edit legend at the bottom the screen and you'll see the current cab, mics 1 and 2, plus the room mic(s), as well as the option to tweak the master level, add EQ, compression, delay and reverb. Twist the Rig selector while you are in this screen and you'll see everything update as you go round. To edit you choose a basic cabinet type from a graphic menu of 1x12, 2x12 and 4x12, and tap the one you want from the images and descriptions presented. Do the same with the mics, only here you have further options in settings for level

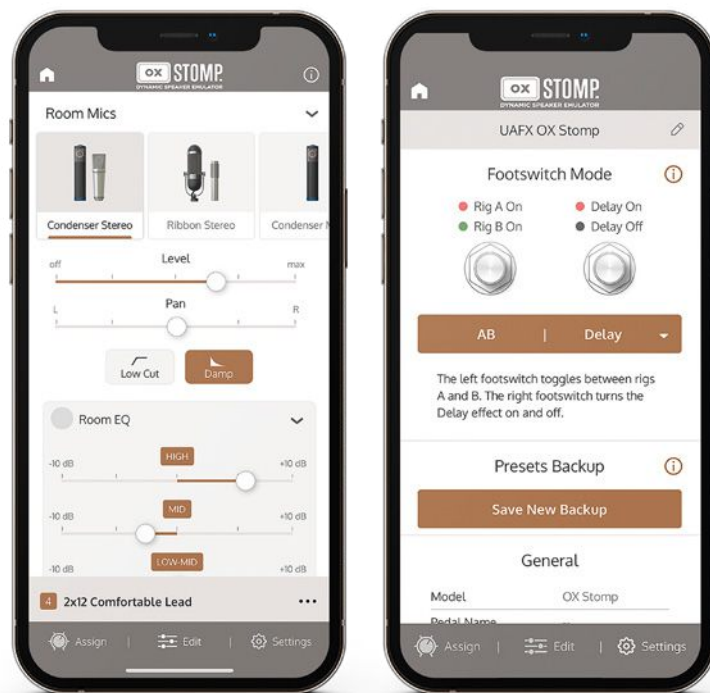

The app gives access to the full line-up of OX cabs, mics and effects, but with a simplified interface for use on mobile devices.

## Universal Audio OX Stomp

£380

### PROS

- With the right source, it offers top-class miked speaker sounds that can be DI'ed.
- Makes UA's Dynamic Speaker Modelling more affordable.
- A useful amount of control available from the hardware.
- UA-quality effects on board.

### CONS

- The UAFX Control app is a work in progress.

### SUMMARY

UA's excellent speaker and mic modelling from their OX amp-top box in a compact pedal format. Feed it something that sounds like an amp and it can take you all the way to a polished, pro-engineered guitar sound.

and pan, as well as a low-cut filter and off-axis positioning. In the case of the room mic, off-axis becomes Damp(ing) to rein back the liveliness of the room sound by adding some virtual baffles and carpeting. The mics have individual pan settings, so if you're outputting in stereo, you can send each one out of a different output, which allows separate post-processing in your DAW mixer. You'll also have to fully pan them if you want

to maintain the complete stereo width of a stereo source. It pays to be aware that some of the factory presets are hard panned, so you'll only hear one of the mics if you just have a mono connection.

Master EQ is a four-band affair, plus high- and low-cut filters, whilst the compressor models an 1176 with the usual control set: input, output, attack, release and ratio, with settings of 4, 8, 12 and 20:1, plus the infamous 'All' for all ratios selected at once. The EQ stage here is post-cabinet, pre-effects, so akin to adjusting a console channel EQ on a miked-up amp, but there's no indication of the actual frequency of any of the bands. Of course, >>





— The OX Stomp can be used to add UA's dynamic speaker modelling process to other modelling units that have IR-based speaker simulation.

» you can do it by ear if you're just being creative, but if trying to solve a problem at, say, 750Hz, you won't know if 'Mid' or 'Low Mid', or neither, will do the job. The delay section has plenty of options: Dual, Crossover, PingPong, Chorus and Flanger, but no delay-time readout, just 0.14ms at one end and 3.0 seconds at the other. Personally, I'd happily lose the choice of six modulation waveforms for a bit more basic information. There are independent settings for two delay channels as well as the ability to link them, plus Mix, Feedback and Modulation Rate and Depth. Practical delay mixes exist primarily in the bottom 10 percent of the slider. I'm not sure how often you'd use any of the other 90 percent unless you were using 100 percent wet in a 'wet/dry' setup. Reverb offers Decay time, stereo Balance, Treble and Bass EQ and Mix, with the wet/dry Mix parameter having a sensible scaling (15 percent wet is at the halfway point), which gives you plenty of resolution around the likely working area. I'm not sure why that hasn't been done for the delay as well.

Unlike the 'full-fat' OX app, this is not a graphics-rich interface. All parameters are presented on horizontal sliders that are, admittedly, more practical for a small-screen mobile interface, but still are not an efficient, precision UI in my experience. That said, there's some useful double-tap and tap-and-hold implementation that offers instant resets or finer-resolution operation. In practice, as a relatively light user, the thing I miss

most in this interface is a gain-reduction meter for the compressor. It's always difficult to hear the onset of compression on a single-instrument signal, which makes subtle settings become guesswork. If we can't have a proper gain-reduction meter, then just flashing or pulsing something on screen to indicate the signal rising over the threshold would be a whole lot better than nothing.

### Applications

Direct recording using a guitar-amp simulation preamp/pedal (or a real amp with a load box) is one obvious application for the OX Stomp, but with ever more venues being volume-restricted or even going

**“It offers a degree of instant adjustability and fine-tuning that goes beyond anything you can conveniently achieve by swapping one IR for another.”**

'silent stage', the use of amp modelling in live performance is ever increasing, and the OX Stomp clearly has a role to play there too. Mounted on the end of a pedal chain that includes an amp simulator (with its own speaker sim switched off) it offers a degree of instant adjustability and fine-tuning that goes beyond anything you can conveniently achieve by swapping one IR for another within a modeller or IR loader, even without using the UAFX Control app.

The OX Stomp's unbalanced outputs mean you'll want a DI box (or two,

if stereo) for a feed to the PA of any significant distance, and if you are using a powered, full-range, PA-type speaker as an on-stage monitor, you can just hook into the speaker-emulated signal via the DI box's thru connector. Whatever's going to front-of-house is then also going to your monitor(s): speaker sim, miking and effects. If your preferred way to use a modeller on-stage is feeding a power amp and real guitar speaker, whilst still wanting to send a speaker-simulated signal to FOH, you can obviously split the signal at the modeller output and send separately to your stage rig and to the OX Stomp for the PA. Of course, you won't then hear any of the effects that may be in the PA feed in your on-stage sound, but there is a neat workaround. The inclusion of a neutral-sounding virtual DI box as one of the 'microphone' choices in the app allows you to set up a hard-panned virtual cab and mic signal feeding one OX Stomp output, going to the PA, while the other output carries a 'clean-feed' version using the virtual DI to your on-stage power amp and speaker. Both outputs will then have the effects in them. Both signals will now also be mono, but personally, I wouldn't ever be too precious about that in a live-sound environment. You will need to create dedicated Rigs specifically for this scenario in the app, although if you never use stereo, there's no reason not to create all your rigs like that.

There's a lot of flexibility in the footswitch programming. Each one can toggle between a single Rig and bypass, or between two Rigs in A/B mode, and as there's a second footswitch, that means you can have four Rigs on tap for footswitch recall, with the second one being designated as in C/D mode. Alternatively, one footswitch can be set to A/B toggle two rigs, while the other switches Delay, Reverb or All Effects on and off. If you don't need to switch Rigs at all, you can program one footswitch to toggle Delay on and off, while the other does the same for Reverb.

### Keep It Simple?

Bringing a lot of the functionality of the OX, with its intuitive, graphics-rich interface, into the more constrained world of the mobile app was always going to be a challenge. The joint functionality between the pedal and the app feels

slightly more complex than the other UAFX pedals: this one can access multiple presets for instant recall from the hardware. Of course, you don't have to use everything it can do. Unless you really must swap out your speaker cabinet from one song to the next — something I have to say that I've never wanted to do in live performance — my 'Super Simple Guide To OX Stomp' says use the app initially to select the speaker cabinet you like best, assign it to all six Rigs on the dial and shut down the app. Now you can play with the mic-selector switches and level controls, the room sound, and the Speaker Drive parameter and output level until you hear something you like. Save it, if you want, by pressing and holding the left footswitch, and move onto the next Rig position on the dial to do the same again. Or just carry on playing through Rig 1, because it is already doing exactly what you want in replicating the sound of a miked-up speaker cabinet.

Of course, there's tons more you can do with the OX Stomp via the app, but you can still do a lot just from the hardware alone. If there were just one thing I could change here it would be that by default both hardware mic switches select from a choice of the Dynamic 57, the Condenser 67 and



— The OX Stomp has a limited number of physical controls on board, with much deeper, detailed control and editing available via the UAFX Control app.

the Ribbon 121. If the second mic switch defaulted to the app's alternate choice in each category (Dynamic 421, Condenser 414 and Ribbon 160), you'd instantly have more choices when running in 'hardware-only' mode.

If it seems like I've mentioned ways to avoid using the app rather a lot, it's because that's what I actually do with these UA pedals. I'll use the app to make a few fundamental settings and then just use the pedals as hardware, thereby avoiding the frequent restarting of the host device and Bluetooth pairing that seems to be the only way that I've found I can manage to keep the app connected. I hope UA manage to improve on this soon, but in the meantime I prefer to think of it as in ongoing development and not to be relied on more than necessary.

— The app's factory presets are often a good starting point for tweaking a sound to your own requirements.

It is the sheer quality of the sound that makes me want to use these UA pedals. Anything else is secondary.

## How Good Is OX Stomp?

Like any digital processor, the OX Stomp has some latency (under 3ms), and it pays to be aware of that number in what you choose to partner it with. Another UA amp pedal will add the same amount again (digital effects with analogue dry thru don't add anything unless set 100 percent wet): still acceptable, until perhaps you add something else, like a trip to a digital FOH mixer and back, and then wireless in-ears. All latency is cumulative, and even studio monitors that have significant DSP on board have a small amount of it! An analogue source is an obvious option to consider, but you may be disappointed if you just feed a drive pedal or preamp into the OX Stomp. Ideally, you want an analogue pedal/processor that replicates a power-amp stage as well as a preamp, but without an integral speaker sim. Or at least with one that can be switched off.

I had great success using an Origin Effects RD Compact, and even a SansAmp Classic — the latter can't defeat its speaker sim, but it is so sonically 'neutral' that the OX Stomp can still give it some 'real speaker' characteristics. You can even dramatically improve some of the amps in an old Line 6 Pod (though for others it's less successful, as if the amp voicings have already been skewed to overcome the limitations of some of the onboard speaker sims). The OX Stomp can also be a great learning tool: turn off all the mics and you hear nothing; turn them up one at a time and compare a 57 with a ribbon, or listen to what the room mic really adds by hearing it with the close mics turned down.

So, how good is the OX Stomp? It is very good at what it is designed to do. But the success of what it is designed to do is very dependent on what you put into it. A version of the OX Stomp that also modelled a tube power-amp stage would work better with a wider range of sources and probably satisfy more users — maybe that's one for the future. But what we have right now certainly does what I expected of it. Personally, I could live forever just in Preset 1, '4x12 Green Punch'. Now that's what a perfectly miked 4x12 should sound like! **////**

£ £380 including VAT.  
W www.uaudio.com

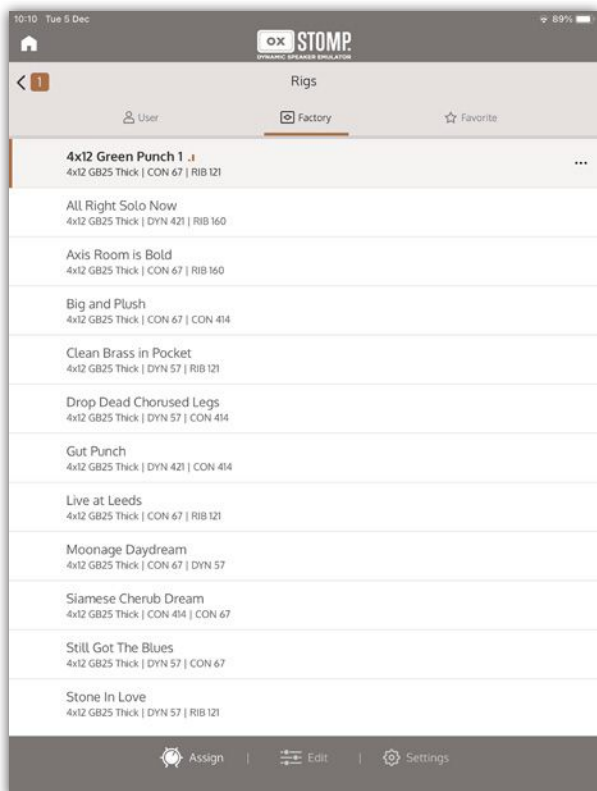





# Arturia Efx Motions

## Multi-effects Plug-in

Arturia's latest effects plug-in is designed to help you keep things moving...

JOHN WALDEN

The last couple of years have seen some absolutely brilliant creative multi-effects plug-ins released, and we've reviewed a number of them, including Cableguys' ShaperBox, Lunatic Audio's Narcotic, UJAM's Dynamo, DA Audio's Tantra and, most recently, Baby Audio's Transit. If your ear candy jar is

running empty, pretty much any of them could be added to your 'contenders list', alongside longstanding favourites such as Output's Movement or Sugar Bytes' Turnado or Effectrix. And now, Arturia can be added to that list too: their new Efx Motions is a creative effects processor designed, as the name implies, to inject some movement into your sounds. All the usual plug-in formats for Mac and Windows hosts are supported, including AAX, AU, and both VST2 and 3.

### Motion Picture

At its core, Efx Motions comprises two suites of functionality: a range of effects, and some powerful modulation sources. The effects options include: a set of five individual effects modules that can be

arranged in a user-defined order; a Beat Repeat section (glitch-style effects that can be triggered using a step sequencer system); and a dual effects processor that can be used to add conventional delay or reverb effects but also has a number of other options. Each of the five main effects modules includes its own Motion Envelope system and, in addition, there are three global modulators that can be configured as envelopes, step sequencers, random generators or envelope followers. There are also two macro knobs which can be linked to multiple parameters for additional control. Any/all of these virtual knobs (or, indeed, any individual parameter) could easily be linked via the DAW to a hardware controller for hands-on sound tweaking.

Those two macro knobs are located top left of the UI in the plug-in's main 'dashboard'. This topmost strip provides access to the extensive collection of presets that are neatly organised into categories (Gated Rhythms, Glitches, Modulated Filter, Risers, Stutters etc.) and you can, of course, create (and save) your own. The central part of the dashboard area provides the Crossover display, allowing you to confine processing to a specific frequency band. Used with the global Output and Wet/Dry controls, this allows plenty of flexibility to blend unprocessed and processed signals together in some interesting ways.

### Just For Effect

The rest of the UI is dominated by the Core section, and this is where we find the five main effects modules (Noise, Drive, Filter, Volume and Pan), which can be drag-dropped to change the processing order. Clicking on a module header brings it into focus, allowing you to adjust a whole range of properties for that module, such as the specific flavour of effect to be used, various parameters and some of the modulation features. Each module provides pretty much what you'd expect. So, for example, the Filter module includes filter types drawn from

some of Arturia's synth emulations, and there are 10 different styles of distortion to choose between in the Drive module.

The Noise module is particularly quirky — in a good way! It includes a huge selection of noise sources and styles that you can blend into your signal, including various Foley-style ambiances. These are based on embedded audio files of about eight seconds in length, and for each type of noise and you can import your own WAV or AIFF files; longer files are compatible but only the first eight seconds will be used. If you have any modulation applied or any other effects in your chain, the fact that the noise component is derived from a short loop isn't something you notice, other than in a few of the Nature or Foley sources (for example, bird sounds or people laughing). While you can use this module to add textures or lo-fi grunge to a sound easily, the other main application is, with suitable modulation of the noise level, to create a noise-based 'woosh' riser. So while Efx Motions might not have 'transition' in its name, it can certainly be used in that context.

The Beat Repeat section hosts three further effects systems: as well as the main Beat Repeat area there are two effects sections that offer a number

## Arturia Efx Motions

€99

### PROS

- Well-designed UI makes a deep feature set very accessible.
- Brilliant tool for adding all sorts of ear candy to almost any sound source.

### CONS

- None.

### SUMMARY

A powerful creative multi-effects processor with a slick GUI and a price that's right — electronic music producers in particular will love it.

of processing options, split into five categories (Ambience, Modulation, Distortions, Dynamics and Filter/EQ). While this whole section is placed after the five modules I've already outlined above, the user can change the order of these three components. And although the effects in the Beat Repeat section don't get their own modulation envelope, you can link parameters to the global modulation options outlined below.

I have to say that the main Beat Repeat section is very cool. It reminds me a little of Sugar Bytes' Effectrix, in that it allows you to trigger creative DJ-style effects using a step-sequencer. It does take a little experimentation to get your head around what's possible here, but there are some good presets to help get you started, and with sound sources such as drums (via the Roll and Reverse effects, for example) or melodic lines, it can add all sorts of extra sonic details to your underlying sound.

### Keep On Moving

While the effects provide plenty of sound-shaping possibilities, the thing that puts the motion into EFX Motions is the powerful array of modulation options. There are so many details that I can't possibly cover all the possibilities here, but hopefully what follows will provide a sense of the potential.

For the five core effects modules, the Motion Envelope section is a sensible starting point. You get a fully customisable envelope that targets a key parameter in the module, with lots of preset curves, full user editing and a smoothing function. On the far left, the panel provides a number of different ways the envelope can be triggered including the Clock mode, where the envelope can just loop (with control over the tempo sync to your



The Motion Envelope for each module can be triggered in a variety of ways including based upon the dynamics of the input signal.



The Beat Repeat panel allows you to step-sequence a number of DJ-style effects to add further interest.



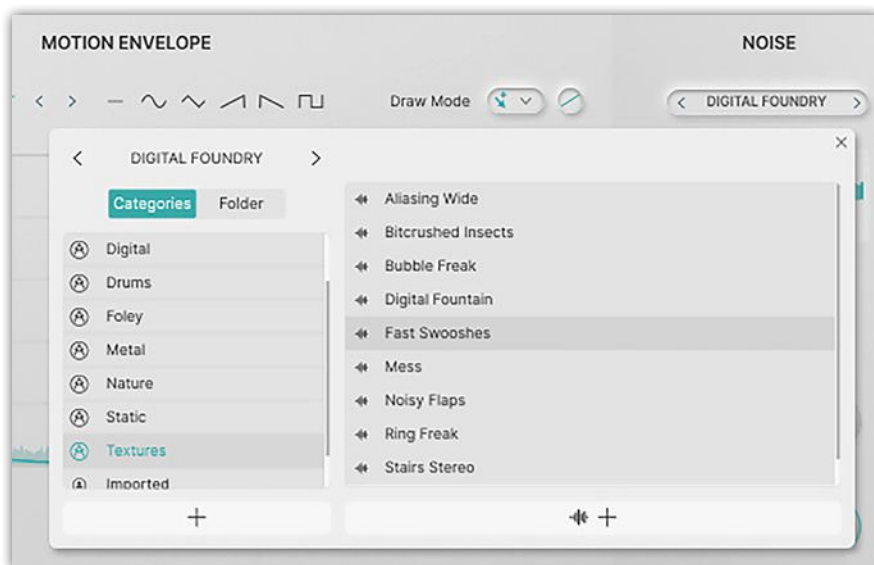

The Noise module includes a wide range of noise types to add further character to your sounds, and you can also load your own WAV or AIFF files.

» host project). However, other trigger modes include an Envelope Sequencer, a Euclidean Sequencer (both of these can create some really interesting rhythmic triggers), MIDI (uses MIDI notes) and Transient mode, where you can set a threshold at which the incoming signal triggers the envelope. There is also a Dynamics mode, and this essentially provides an envelope follower, where the amplitude of the incoming signal controls the shape of the envelope. So, for example, if you want more distortion on louder parts of the signal, this is one way to get it.

Providing you've activated the Advanced button (top right in the dashboard section), you also get access to the three global modulators at the base of the UI. These can each be configured as envelopes, step sequencers, random generators or envelope followers. Again, you're given full control over the nature of the envelope or sequencer and its tempo synchronisation. However, what's cool is the ease with which you can then link a parameter to this modulation source:

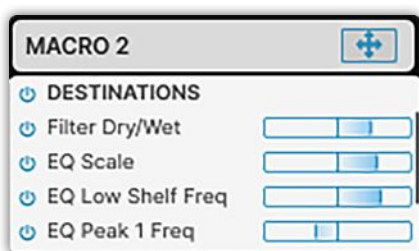

Assigning targets to the macro knobs or global modulation options is a simple drag-and-drop process.

just click and hold the small icon to the right of the panel's label until a small X/Y arrow icon appears, then simply drag and drop that onto the target parameter. You can then set the range over which the target parameter is modulated too. Multiple targets can be triggered by each of the three global modulators, and if you want to make things really interesting you can modulate the rate of one global modulator from another — apply the results to distortion or volume and some spectacular glitching effects can be created. Assigning targets for the two macro knobs is done in the same way as with the global modulators. These also support multiple targets and allow the range of modulation to be specified on a per-parameter basis.

I've outlined the broad-brush strokes of what's possible, but as with the majority of the creative multi-effects plug-ins I mention earlier, Efx Motions will undeniably deliver the best returns to those who are prepared to invest a little more time. Do that and you'll find that it's not only capable of some excellent results, but that it can transform even the blandest pad into your mix's rhythmic highlight. Yet it's not just for pads: there's something here to treat or transform almost any sound source. For example, applied to drums, you can conjure all sorts of extra sound elements out of a quite simple loop. Extra bleeps and bleeps, stutters, reversed hits, hats with cool delays that are crossing the stereo field while also being filtered... It's cool on guitars, bass synths, keyboard block

## ALTERNATIVES

I've mentioned a number of other creative multi-effects plug-ins in the main text, but perhaps the closest point of comparison is **Baby Audio's Transit**, which was released very shortly before **Efx Motions**. The two plug-ins have been pitched in somewhat different ways, with Transit billed as a 'transitions designer' and Efx Motions as a more general creative effects designer, and they offer different workflows. But in practice both can easily fulfil either role, and both are excellent too. So a choice between them would probably come down to personal workflow preferences as much as anything else — and that's something you can judge using the free trial versions.

chords, turning simple melody lines into something wildly more interesting, and it can do some great vocal tricks too. As mentioned before, whether through the tempo-sync'ed modulation system or the macro knobs, if you want to apply these kinds of processing possibilities with increasing intensity over a number of bars to build up to a transition, Efx Motions will let you do that too.

Importantly, though, while it's certainly pretty deep (particularly in terms of the modulation possibilities), Arturia have done a great job in designing the UI to make what's a sophisticated set of control and modulation options nicely accessible.

## Motional Support?

Arturia rightly pitch Efx Motions as a creative multi-effects processor — while it's capable of some conventional ambience, modulation or distortion effects, if that's all you want this is not going to be the best choice. But if electronic and modern pop production is your thing, or perhaps if you're a media composer looking to expand your collection of 'weird and wonderful' sound-design tools, this new Arturia plug-in should be right on the money. And talking of money, given what's on offer here I reckon Efx Motions is competitively priced. For all the madness that can be found in the modern world, the little section of it that is music technology contains some astoundingly good stuff. Arturia's Efx Motions is an excellent example of that; it's a brilliant tool for banishing bland from your music productions. **///**

£ €99  
W [www.arturia.com](http://www.arturia.com)

# GRANDCHILD

670 500

Finally...The *FAIRCHILD* for the rest of us!



The sound of yesterday  
built for tomorrow.

MSRP:  
1.999 €

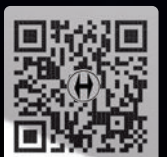

GRANDCHILD



# GC Audio Inherit Series

MATT HOUGHTON

Inherit is a modular system by French manufacturers GC Audio and although, at the time of writing, there are only mic preamp modules available, designer Guillaume Chauvet tells me he has plans to develop processors too. The modules come in the form of chunky metal cartridges, and thus far none have their own user controls — the 2U host chassis, into which they slot, provides a common set of controls, as well as power and analogue I/O. Most of us already have access to clean gain in our audio interfaces, and the idea here is to allow quick and easy swapping of mic preamps when you want something more characterful. Notably, the modules are hot-swappable, making the auditioning process painless: no patchbay, no swapping of cables or unplugging of mics, and no need to switch phantom power. You just pull out a cartridge, pop another in and listen. The metal cartridges shield the electronics inside. They're slightly larger than 500-series modules, the chassis has higher-voltage power rails and there's plenty of current available, so designers don't face the same challenges.

## Overview

The gloss-black front panel has white legends and a single cartridge slot in the centre. This is protected by a spring-mounted blanking plate, and inserting a cartridge is easy: push it in, the plate falls back and it's guided neatly into

## Modular Microphone Preamp System

Contrary to popular reports, preamps don't all sound the same — and this clever system makes it easy to hear the 'magic'.

place. Above, 10 generously spaced LEDs, each in a metal mount, form a meter that can display the level pre- or post-preamp. The first five LEDs (-20 to -1 dB) are green, then the 'zero' point is orange and three red LEDs then take you 1dB at a time up to +3dB. Setting gain for the desired saturation and output level is easy, and the meter can be helpful for performers who want to ride their level in and out of distortion territory for creative effect.

The main Gain control has 12 steps, and is marked simply 1-12. It feels like the sort of analogue switch found on many high-end preamps, but is actually a digital control that communicates with the preamp. To the right of the cartridge, an output attenuator ranges from unity gain (fully clockwise) to full attenuation (anticlockwise).

On the left, three large, backlit, bevel-mounted

metal buttons engage +48V phantom power, invert the signal polarity and pad the input signal down; as with gain, the pad value is determined by the preamp rather than the host rack. There's also a TS jack instrument input, and a plug patched into this takes precedence over the XLR mic/line input on the rear. Again, what happens to the signal you patch in here is down to the design of the inserted module; there's no instrument preamp stage built into the chassis. Beneath the Output knob is a high-pass filter (80 or 120 Hz, or Off), and it's nice to see a large on-off button on the right of the front panel, where it's accessible. Finally, joining the XLR input on the rear are an



XLR output and an IEC inlet for 115/230V AC mains, stepped down inside by a vertically mounted toroidal transformer.

### In Use

Sent for review were an Inherit Rack and several cartridges. Most of the latter were Guillaume's designs, but there were also a couple of 'signature' models. Armed with a selection of mics, I use the system to track various sources, including my own voice, electric guitar (both DI'd and a miked Fender Blues Deville combo), DI bass guitar and some percussion (kick, snare and tambourine). I also tried 're-preamping' some clean recordings. The first thing to note is that the preamps all sounded good and were evidently of high quality, but what struck me was just how different they could sound. Don't get me wrong, I could get most to sound broadly neutral with modest amounts of gain, but the gain and output knobs and the meter really encourage you to search for the saturation sweet spot or, depending on the source, the more obvious sound of overdrive.

So, what do the specific preamps have to offer? The first I tried was the **Gyraf GY 4.5**. Housed in a black cartridge, this was designed by Jakob Erland and is, essentially, his G9 preamp in this new form factor. It employs two ECC82 dual-triode

valves (on high-voltage rails) and Lundahl input and output transformers. I thought it lovely: classy, clean, lively and somehow 'three-dimensional'. It shone brightest on vocals (even mine!), bringing out the details in delicate, breathy and whispery parts, but also handling belted-out rock leads with ease. It partnered various mics nicely in this role; I tried a ribbon (sE Electronics RNR1), a couple of dynamics (Heil Sound PR40, MXL BCD-1) and a couple of capacitors, including my favoured AKG C414 B-ULS. Since it breaks up so gracefully, the large meter meant I could easily capture a nice clean vocal in the verses of a rock song, and then open up in the choruses to provoke a little distortion to help my voice cut through against a dense wall of guitars. It's technically possible to route an instrument signal through this preamp, but it's a coloured, distorted sound; for a clean DI sound you'll want an external DI box or one of the solid-state cartridges.

The other 'signature' model is the **Graham Langley**, which comes in a striking magenta cartridge and is a solid-state differential amplifier offering 16-60 dB of gain. I've always liked Langley's Amek consoles (I reckon they're under-appreciated today) and it's based on those designs, though tweaked to improve the technical specs. As you start to increase the gain, it sounds effortlessly clean, with very low noise until, eventually, it starts to distort in a controlled and tasteful way. This preamp doubles as a very

## GC Audio Inherit Series

### PROS

- Clever hot-swap mic preamp system.
- Beautifully built.
- Makes comparing preamps for specific sources quick and easy.
- Generously sized metering.

### CONS

- Not clear at a glance which preamps work with instrument inputs.
- You want several cartridges to make it worthwhile.

### SUMMARY

For those who like to tailor their mic and preamp choices for specific sources, the Inherit system has a lot to commend it — not least the universally high quality.

nice DI, and if I had the rack with the GY 4.5 and Langley cartridges, I don't think there's be many bases left that I'd need to cover unless I was, say, searching for a specific console preamp sound.

Another valve-based option is GC's blue **Tube Heat**. This offers the same 66dB maximum gain as the GY 4.5, is likewise based around two ECC82 valves, and has input and output transformers. But its minimum gain is +26dB, so the gain range is narrower, and the 12 gain control steps give you finer control. Again, it can be a pretty creative tool, with the combination of gain and output attenuation making it possible to use it as a nice vocal preamp or, say, an appealing line-level saturation box. Note, though, that if you're recording anything that requires lashings of gain, it will also bring up plenty of hiss. Like the Gyraf, this preamp hasn't been designed to deliver a clean instrument sound. »







GC's **RE-98** is housed in a turquoise cartridge and is a clone of the solid-state preamp from an unidentified "1990s British console" which I suspect from the name is the Amek 9098 (from Amek's 'Rupert Neve years'). It offers a gain range of +1 to +66 dB and features a Lundahl 1585 output transformer. Again, this one sounds pretty clean and quiet, though a subtle character is introduced as you increase the gain: a little thickening at the bottom end, but a greater effect in the highs — it sounds a touch richer and more 'alive' than my audio interface's preamps. To take it into more obvious distortion territory requires more gain than most other preamps here, and when you arrive there it's the sort of sound I associate with driving a good console preamp. This one works well with instrument signals, and offered up a satisfying bass guitar sound.

Their **RE-VR** (a striking tangerine colour) is yet another console-derived preamp, and this time we're told it's based on a 1980s British mixer — presumably a Neve VR-series. Unsurprisingly, it sounds decent and I'd regard it as a good, general-purpose studio preamp. It's evidently not been designed for DI'ing, but when I played bass into this preamp through a clean-ish DI box (by DAV Electronics) it sounded lovely: tight and snappy, yet simultaneously deep and full-bodied. The character when overdriven is pretty fuzzy, which, again, could be lovely on bass guitar. The red **RE-73**, meanwhile, is a high-quality reproduction of the classic Neve 1073

■ The stepped gain and continuous output attenuation knobs, along with a large level meter, make it easy to find a preamp's sweet spot.

preamp whose sound most of use will know — I probably don't need to say more about that here!

No prizes for guessing that the black **RE-4K** cartridge is based on the preamp of the SSL 4000-series console. It's lovely and clean, and when you start to get into breakup territory the transition is gradual, making it easy to achieve the precise amount of distortion desired, and there's arguably less by way of audible nasties if you start straying into that territory unintentionally. Again, you'll fare much better with instrument sources if you use a DI. A small quirk — though not a problem in practice — was that with the gain knob set to a position between switched steps, I heard a low-level 'whistle'.

GC's **RE-15** is an op-amp-based preamp that, again, sounds very clean. Its USP is its very low noise floor, and it's a lovely preamp that I couldn't fault. Having said that, I did wonder if I'd really want one for this system, whose raison d'être I see more as offering a menu of more characterful options than my mixer and interface already cater for. Another option, not sent with the review model, is the **RE-11**, which is the most affordable cartridge currently on offer; it might be a useful alternative to a more colourful cartridge, though again I suspect most engineers/studios will probably already have something to cover this base. On the

other hand, if you buy all the others, this one is a free bonus...

## Verdict

The Inherit Series has a lot to commend it. It's all beautifully built and intuitively laid out, and the preamps all sound great. The speed and ease with which you can audition different preamps is a joy; I love that you can hot-swap them and just focus on the sound. It's so easy to be creative with the distortion, and this could definitely be viewed as a line-level processor as much as something for amplifying mics. Of course, assembling an Inherit setup with sufficient options to make it worthwhile could prove expensive, particularly if you're drawn, as I was, to the valve and signature models. Also, while the rack works well, I think its functionality could usefully be extended. Notably, the integration of a clean-sounding DI would allow you to audition instruments with any preamp more easily — in the absence of that it would be good to have an indication on the cartridges as to their suitability for instruments. A low-pass filter might be a worthwhile addition, to tame the hiss when using the valve preamps at higher gain settings. As for the modules, my wish list definitely extends beyond preamps: saturators, tape emulators... there's plenty that could be exploited. But, in the meantime, I've definitely enjoyed playing with the Inherit system. If you already have clean mic amps, like to audition 'character' preamps for specific sources, and have the necessary funds, it's well worth checking out. ■■■



■ The main audio I/O are on XLR connectors, while a standard IEC inlet connects the internal power transformer to 115/230V mains AC.

£ Inherit Rack £1020. Cartridge preamps range from £288 (for the GC Audio Inherit RE11) to £1529 (for the Gyraf Audio GY 4.5). Prices include VAT.

T KMR Audio +44(0) 20 8445 2446.

E sales@kmraudio.com

W www.kmraudio.com

W www.gc-audio.com



**NEW!**

# Introducing SuperPlate

AN EXPANSIVE REVERB EXPERIENCE



SuperPlate brings the unique tonal character of five classic electromechanical plate reverbs into your studio - without the massive investment and back-breaking weight of the originals. Its advanced algorithms capture a level of unmatched realism and versatility and create luscious, immersive effects.

Get ready to expand your tracks into spaces and places the original hardware only dreamed of.

The new Soundtoys 5.4 bundle combines SuperPlate with a full suite of effects from analog-modeled saturation and distortion, tape echo, filtering, EQ, and modulation.



**\$149 MSRP**

Trade up from Little Plate to SuperPlate for \$59  
Free 30-day trial at [soundtoys.com](https://www.soundtoys.com)



# **SOUND ON SOUND** **AWARDS**

Chosen By The Readers Of *Sound On Sound*

This year's SOS Awards once again place the emphasis on innovation and contemporary design, with the nominations being limited to products launched in the 12 months prior to the voting period. These results celebrate the 'best in class' products launched or reviewed in the period from September 2022 through to the end of August 2023.

You'll see all the winners you selected here, as well as the very worthy close contenders in each category who have been awarded our Highly Commended accolade.



**WINNER**

BEST AUDIO INTERFACE

**FOCUSRITE SCARLETT 4TH GEN**

[www.focusrite.com](http://www.focusrite.com)



**WINNER**

BEST DAW

**APPLE LOGIC PRO**

[www.apple.com](http://www.apple.com)





**WINNER**

**BEST EFFECTS & PROCESSING HARDWARE**  
**EVENTIDE H90 HARMONIZER**

[www.eventideaudio.com](http://www.eventideaudio.com)



**WINNER**

**BEST GUITAR & BASS TECHNOLOGY**  
**IK MULTIMEDIA TONEX PEDAL**

[www.ikmultimedia.com](http://www.ikmultimedia.com)



**WINNER**

**BEST SOFTWARE PLUG-IN**  
**IZOTOPE OZONE 11**

[www.izotope.com](http://www.izotope.com)







» **WINNER**  
BEST MUSIC SOFTWARE  
**SONARWORKS SOUNDID  
REFERENCE FOR MULTICHANNEL**  
[www.sonarworks.com](http://www.sonarworks.com)



**WINNER**  
BEST PERFORMANCE CONTROLLER  
**ABLETON PUSH 3**  
[www.ableton.com](http://www.ableton.com)



**WINNER**  
BEST DRUM MACHINE  
**ROLAND SPD-SX PRO**  
[www.roland.com](http://www.roland.com)



**WINNER**  
BEST KEYBOARD/SYNTH  
**ARTURIA  
MINIFREAK**  
[www.arturia.com](http://www.arturia.com)



**WINNER**  
BEST STUDIO  
MONITOR  
**GENELEC  
8381A**  
[www.genelec.com](http://www.genelec.com)



**WINNER**  
BEST MICROPHONE  
**LEWITT AUDIO  
PURE TUBE**  
[www.lewitt-audio.com](http://www.lewitt-audio.com)

**WINNER**

BEST MIXING CONTROLLER  
**SSL UF-1**

[www.solidstatelogic.com](http://www.solidstatelogic.com)



**WINNER**

BEST HARDWARE  
AUDIO RECORDER  
**TASCAM  
PORTACAPTURE X6**

[www.tascam.com](http://www.tascam.com)



**WINNER**

BEST MICROPHONE PREAMP  
**RUPERT NEVE DESIGNS NEWTON CHANNEL**

[rupertneve.com](http://rupertneve.com)



**WINNER**

BEST HEADPHONES  
**AUDIO-TECHNICA  
3000 SERIES IEM**

[www.audio-technica.com](http://www.audio-technica.com)



**WINNER**

BEST SOFTWARE  
INSTRUMENT  
**ARTURIA V  
COLLECTION 9**

[www.arturia.com](http://www.arturia.com)

**WINNER**

BEST LIVE  
SOUND PRODUCT  
**ALLEN & HEATH  
CQ SERIES**

[www.allen-heath.com](http://www.allen-heath.com)







» **HIGHLY  
COMMENDED**  
SOS AWARDS 2024



DAW  
**STEINBERG  
CUBASE PRO**  
[www.steinberg.com](http://www.steinberg.com)



SOFTWARE PLUG-IN  
**SOUNDTOYS SUPERPLATE**  
[www.soundtoys.com](http://www.soundtoys.com)



MUSIC SOFTWARE  
**STEINBERG SPECTRALAYERS PRO 10**  
[www.steinberg.com](http://www.steinberg.com)



EFFECTS &  
PROCESSING HARDWARE  
**STRYMON  
CLOUDBURST**  
[www.strymon.net](http://www.strymon.net)



PERFORMANCE CONTROLLER  
**ARTURIA KEYLAB ESSENTIAL MK3**  
[www.arturia.com](http://www.arturia.com)



AUDIO INTERFACE  
**AUDIENT ID44**  
[www.audient.com](http://www.audient.com)



GUITAR & BASS TECHNOLOGY  
**NEURAL DSP ARCHETYPE: RABEA**  
[www.neuraldsp.com](http://www.neuraldsp.com)



STUDIO MONITOR  
**NEUMANN KH120 II**  
[www.neumann.com](http://www.neumann.com)



SOFTWARE INSTRUMENT

### NATIVE INSTRUMENTS COMPLETE 14

[www.native-instruments.com](http://www.native-instruments.com)



MIXER & MIXING CONTROLLER

### AUDIENT ASP4816-HE

[www.audient.com](http://www.audient.com)



MICROPHONE PREAMP

### WARM AUDIO WA-2MPX

[www.warmaudio.com](http://www.warmaudio.com)



LIVE SOUND PRODUCT

### LEWITT AUDIO MTP W950

[www.lewitt-audio.com](http://www.lewitt-audio.com)



MICROPHONE

### NEUMANN M49V

[www.neumann.com](http://www.neumann.com)



KEYBOARD/SYNTH

### CLAVIA NORD STAGE 4

[www.nordkeyboards.com](http://www.nordkeyboards.com)



DRUM MACHINE

### KORG DRUMLOGUE

[www.korg.com](http://www.korg.com)



HARDWARE AUDIO RECORDER

### ZOOM M4 MICTRAK

[www.zoom.co.jp](http://www.zoom.co.jp)



HEADPHONES

### SONY MDR-MV1

[pro.sony.com](http://pro.sony.com)



# Intech Studio Grid

## MIDI Controllers

Could Intech Studio's ingenious modular system help you build your perfect MIDI controller?

ROBIN VINCENT

How often have you been on the lookout for the perfect MIDI controller only to find that you inevitably have to compromise? Either it doesn't have enough knobs, or far too many, or if only the sliders were in a different place. Grid from Intech Studio offers an interlocking system of

MIDI control modules that's completely configurable. Do you want more sliders? Snap-on another bunch of four. Do you want more encoders over on the left? No problem, here's a bank of 16.

There are currently five modules in the Grid system and more are to come. Can you find the perfect custom MIDI controller within these deeply dark and seriously smart modules?

### Hardware

The modules feel substantial in the hand. They are solid, slimline squares of hard matte-black plastic festooned with knobs, encoders, sliders or buttons, depending on the unit. There's a pair of four-pronged spring-loaded pogo pins on each side, and on either edge is a magnet. The magnets snap the modules together while the pogo pins match up with those on another module to pass power and data. You can snap them together in any orientation so that sliders become crossfaders, or the LED for an encoder is below it rather than above it. The system knows which way up everything is and copes with any change, although the USB-C port on one side could be called the top, and the Mode button on the

opposite side could reasonably be seen as the bottom; the controls appear to be orientated to reflect this.

As you construct your controller, the RGB LEDs flash and glow as connections are forged and understandings are come to between modules. You only need a single USB-C connection to provide power and data to the whole Grid and it doesn't matter which one you connect it to.

The encoders feel nice and solid; they turn with detents and are clickable when pushed. The knobs are smooth, with a good amount of resistance and feel slightly more solid in place than the encoders. The sliders feel all right, and I like the very fingerable fader caps. Two of them on one of the review modules dragged a little bit on the front panel, although it's hard to know if this was the fader cap or the edge. The buttons are perfectly fine and buttony. Each individual control has an LED, and for each element that has a maximum and minimum, they increase/decrease in brightness as you move from one extreme to another. The default is a rather pleasing blue, but you also get orange, green and purple to cover all four modes.

### Intech Studio Grid

From \$130 Each

#### PROS

- Amazingly modular MIDI controller.
- Customisation is very slick.
- Good range of module options.
- Huge scripting potential.
- Knot is probably the best MIDI utility for a decade.

#### CONS

- Needs a flat surface.
- Grid Editor can feel complex.
- Profile library is currently small.
- If you're not into scripting, you might feel you are missing out.

#### SUMMARY

The Intech Studio Grid offers a slick modular MIDI controller solution with the potential to be so much more.

The five modules on review here represent the current product line. There's the PO16, which has a 4x4 grid of 16 "potmeters" or potentiometers, and the EN16, which is the same but with endless encoders. There's a 16-button module called the BU16. The perhaps more interesting two have some combinations: the EF44 has four encoders and four long faders, whereas the PBF4 has four pots, four sliders and four buttons. One small irritation is that the name of the device isn't written anywhere on the hardware. Of course, it only takes a moment to work it out, but as I come across them referred in the documentation, I'm forever having to stop and think about it.

On the whole, the Intech Studio Grid is gorgeous. Superbly clean lines, intensely dark controls and not-too-bright LEDs. I found myself endlessly rearranging them partly to enjoy the flashing LEDs of reconnection and partly because I could. And that's the point: they don't have to take on a permanent configuration. You can arrange and rearrange them to fit the device you're controlling. And you probably wouldn't have one of each as I have here; you're more likely to choose the ones that are going to fulfil your own requirements.

## First Play

The online documentation is good, and there's plenty of it, although it could be a little bit more idiot-proof. Being a Windows user, I have an expectation of drivers and installers, and there's no mention of them on the Getting Started page. Am I supposed to believe that it just works? Well, funnily enough, it does, but it would be nice to be told that it will, so I'm not digging around for an installer. However, after you've had a root around, you will find there's an editor and a firmware updater, and these would benefit from being displayed really large on the first page so that I can confirm that the Grid is indeed working correctly before I try controlling things.

I wanted to see how easy it would be to get going intuitively. So,

 The Grid Editor software.

without any reference to the manual or any editing software, I opened up Cherry Audio's CA2600 and hit the MIDI Learn button. Every control mapped with a joyful ease. Except for the buttons which believed themselves to be notes and ones that didn't latch. So they could change the state of some of the 2600's buttons but not move switches from one setting to another.

Once mapped, I could take the modules apart and rearrange them without losing the mapping. Once the connection was re-established, it all continued to work perfectly. Switching modes with the little button didn't seem to achieve anything at this point past a change in LED colour. I assume it will provide you with different configurations or mappings, but as far as CA2600 is concerned, it's the same CCs regardless of what mode you're in. This will bear some further investigation.

Simply as a MIDI controller, the Grid is a lovely thing. The modular nature proved its worth to me in how I can build an interface that best reflects what I'm trying to control. It makes you wonder how that versatility stacks up against the usefulness of muscle memory on a fixed controller. But versatility is the key to the Grid, and that's definitely what you find as you dig deeper into it.

## Grid Editor

All the magic happens in the Grid Editor software for macOS, Linux or Windows. The Editor looks really nice and instantly pointed out the out-of-date firmware and directed me to update. This is relatively harmless and must be

done for each module independently. Your layout is reflected in the Editor's main window, down to the position of each knob and slider. As you rearrange your physical Grid, it all updates in the Editor very smartly. Each module has four pages into which you can build, save and load configurations. When you push the Mode switch on the module, you are moving through the pages. So the idea is that you can design up to four configurations for your module, which can be stored in the device and are then accessible outside the Editor and away from the computer. Intech call these configurations 'Profiles'.

Profiles can be anything from MIDI controller numbers to complex coded happenings. The available selection at the moment is small and a bit muddled. Several are specific to certain bits of hardware, and others do things I don't yet understand. There are a couple of intriguing ones that turn various modules into sequencers or LFOs, and these will need to be explored. The Windows version of the editor has a problem in that you can't see more than the first line of text in the profile description, or at least not on my machine. So, I didn't have much information to go on until I found them mirrored on the Profile Cloud web page, where I could get to the text and full description.

The Grid modules are fully programmable using the Lua scripting language. It is object-orientated and relatively straightforward but also feels like a barrier to configuring your controller if you are not at home with coding. >>>

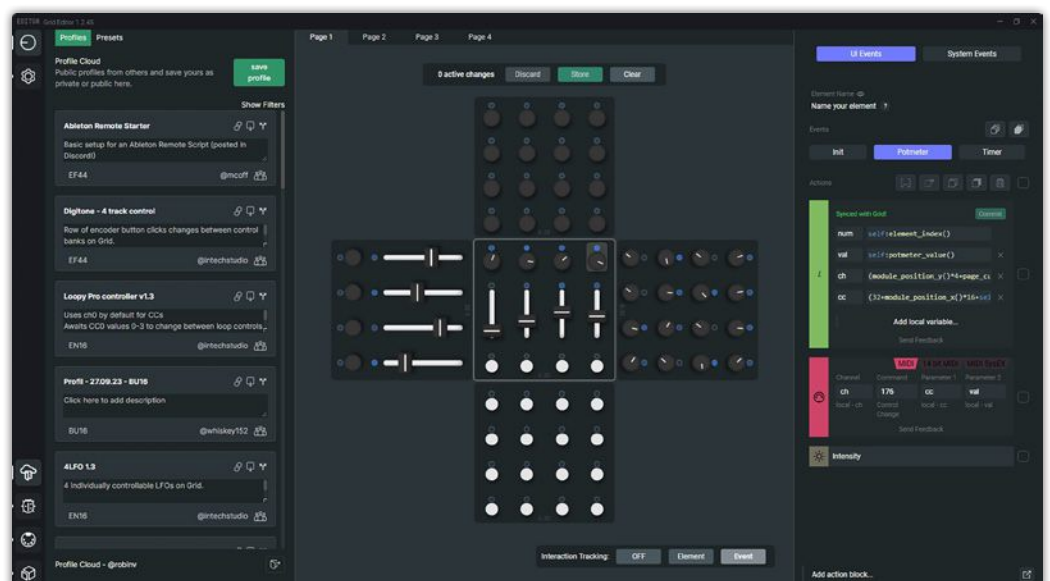



» So, what do we do if we want to change the MIDI channel or controller number on a control? If you move the control then all the scripting information appears on the right. There are a few tabs depending on whether you want to edit the whole module, the initial instructions, the script for the control or the timing of it. For the basic MIDI control profile loaded by default, there are Local actions and MIDI actions displayed for each control. MIDI actions seem like a good place to start, and there's an entry for MIDI channel and CC parameters — hooray! But they are not specified. However, if we

open up the MIDI monitor, we can see that the control is clearly mapped to a specific channel and CC number. Instead, we have to refer to the Local Actions where we find that the channel is defined as “(module\_position\_y()\*4+page\_current())%16” and the CC number as “(32+module\_position\_x()\*16+self:element\_index())%128” — excellent!

I'm not one to shy away from complicated things, and as I mentioned, the online documentation is good and comprehensive, but it's not exactly an easy read. It does tell you that you can simply put in a channel number and CC number in the MIDI Action box, but only after sifting through a lot of information about variables and numeric relationships. It feels like this could be a lot easier. Why not set up the default profiles with defined parameters so that any idiot could edit them without wading through documentation and tutorials?

Well, it's because of the versatility angle. I understand from Intech that they use variables rather than static values to keep the modules dynamic. The MIDI channels and controller numbers are defined in reference to their position and orientation in the Grid. This way, you're never going to have a clash between modules. If you buy two of the same modules and they have static values, then



■ Unattached: clockwise from top left, the P016, EN16, EF44, PBF4 and BU16. Each Grid module has a footprint of 106 x 106mm.

the first thing you'll need to do is open the Editor and change one of them so that they don't control the same thing. With the scripting and use of variables, they all work around each other and out of the box, you can map a complex Grid of modules to anything with a MIDI Learn button. So there's clever stuff going on that's rubbing up against my desire for static simplicity.

Nevertheless, taking my new ability to change controller numbers into another scenario, I was able to rustle up a couple

**“The modular nature of these controllers is superb. Mixing and matching, building to your own requirements and then reworking it is a marvellous thing.”**

of profiles covering the Shift-Control elements on the Dreadbox Nymphes. I could load these up on a single module into separate pages and switch between them with the Mode button. That's exactly the sort of functionality I'd expect from a decent MIDI controller, and once you break through the scripting barrier, it works brilliantly well.

### Doing More With Profiles

There were a couple of profiles that did a good job of showing what's possible with the scripting. The first one was the 4LFO. It transforms the 16-encoder (EN16)

module into a four-channel LFO, each one controlled by a row of four encoders. The first one specifies the CC number for mapping the LFO, the next controls the range, the next one does nothing, and the last encoder controls the rate. You click it to turn the LFO on and off. MIDI Learn it to a control in your favourite soft synth, and it's brilliant. But it's also configured strangely, or at least to my mind. Each LFO is on the same CC but a different MIDI channel. So, in a software synth

that doesn't care about MIDI channels, all four LFOs map to the same control. It depends on the software though; Bitwig Studio was completely fine about mapping all four LFOs to whatever I wanted. For a hardware

synth, you would (normally) control it on a single MIDI channel, so I found that I could only use one of the LFOs and would need to specify the CC number of the parameter I wanted to modulate.

That sounded like the sort of thing I should be able to edit. So I opened the Editor and clicked on the various elements, but I was darned if I could find any reference to MIDI Actions or any recognisable fields. Just lots of blocks of code. I was left feeling that there are bags of potential here that are tantalisingly out of my reach. Talking to Intech, they were able to rustle me up a version of

the LFO that had a field where I could specify the CC number, which again makes me feel like this is only awesome in the right pair of hands.

Another profile I liked was the Gated Step Sequencer. This takes over the PFB4 (pot-fader-button x4) module and gives you four steps going left to right with the knobs providing the pitch, the faders setting the number of repeating gates and the buttons setting three levels of velocity. On a second page, you could also set the gate length for each step. It's really rather neat.

Once you start putting these things together you end up with a very powerful setup: a very playable four-step sequencer, a bank of LFOs mapped to something useful, fader controls mapped to waveform levels, a bank of 16 knobs for all sorts of control and 16 buttons that I didn't quite know what to do with.

The essence of the profiles is that it's a coder's dream. If you know a bit of programming, you could make these things do pretty much anything. But if you're not, you are a little stuck with regular MIDI control. There's nothing

wrong with MIDI control; it's exactly what we expected it to be, but you can't help but feel you're missing a lot of potential. However, the idea behind the Profile Cloud is that people who know how to do these things can share their profiles with the rest of us. I guess this is early days, but a small selection of interesting things for each module would be appreciated, and it would greatly enhance the new user experience.

## Conclusion

My overall experience with the Intech Grid modular controller has been a mix of large swirls of serious hardware satisfaction sprinkled with newbie software frustration.

The modular nature of these controllers is superb. Mixing and matching, building to your own requirements and then reworking it is a marvellous thing. The hardware is decent and roomy, and while they lack any labelling or display, the LEDs do a good job of keeping you informed.

I had some stability issues. Sometimes, the Grid Editor wouldn't see a module, or it would reset or be seen but not working. Some of that is down to my less-than-perfectly flat desk, where connections were not as aligned as they could be. But other issues just seemed to be glitches and the nature of open source software where nothing is entirely finished, and the odd bug is part of the deal.

Tackling the Grid Editor can be a bit bumpy, but there's a huge amount of power and versatility there for the taking if you're prepared to dig into the scripting language. I found that once I'd made a couple of profiles specific to my synths, the hardware experience proved its worth. There aren't very many good examples of what the scripting could offer. I imagine it could be a great generator of modulation, shapes, sequences, and randomisation, but I have no idea how to make those happen. Hopefully, in time, Intech and the open source community of users will come up with some great profiles that can unlock more of the power of these boxes.

I don't want to get hung up on the scripting, though, because, as a MIDI controller, it's a beautiful system. And I love how the Knot will let you seamlessly merge it into any setup. **///**

**£** EN16 \$202.80, PBF4 \$154.80, PO16 \$154.80, BU16 \$130.80, EF44 \$190.80, Knot \$118.80. Prices include VAT.

**W** [www.intech.studio](http://www.intech.studio)

## Knot

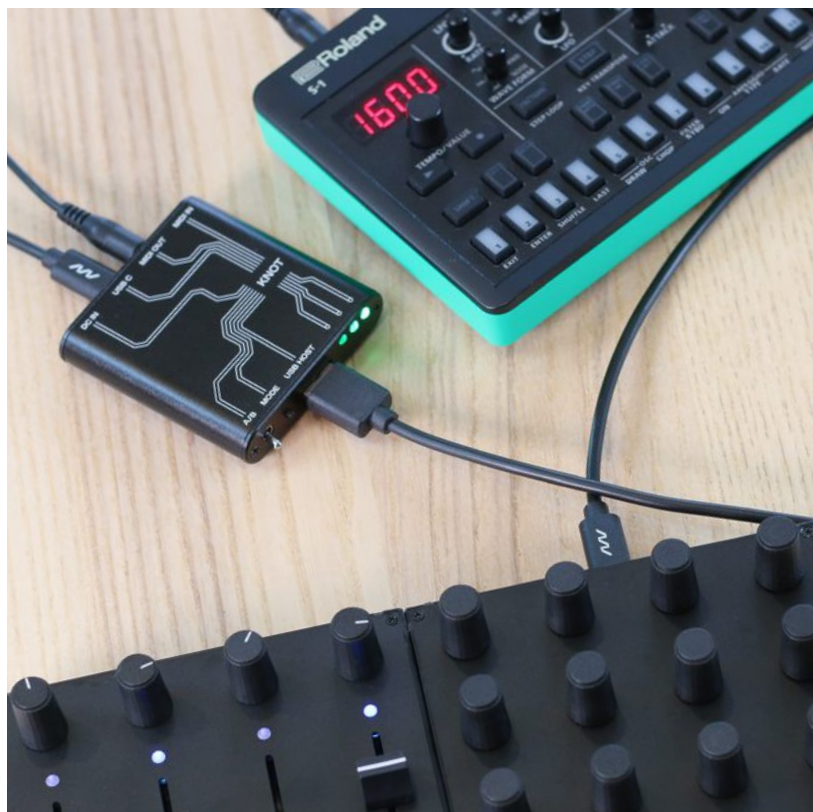

Another little box was included with my review bundle of bits from Intech. It's a curious little thing called Knot. Knot is a USB MIDI host interface. You can plug in a USB MIDI controller, like the Grid, and it will output regular MIDI on TRS (switchable between Type A or B — yay!). It essentially adds a physical MIDI output to any controller that doesn't have one without the need for a computer. What a useful little box.

However, there's another tiny feature that really takes the cake. It also has a MIDI input that can merge with the USB MIDI input. This means you can add or merge your USB MIDI controller with an existing MIDI-port-ended MIDI controller. That sounds more complicated than it is. Let me give you an example: I've got

a MIDI keyboard plugged into a hardware synth. I've got a couple of Grid modules loaded up with profiles mapped to control various parameters on the synth. I drop in the Knot, plug the keyboard into the MIDI input, and the Grid into the USB host port. Both of those controllers will now merge their data into the synth, giving me both keyboard and Grid module control into a single MIDI input. That's pretty awesome.

The Knot needs its own power, but it can take power from USB or any kind of DC supply and will feed it onto any USB-connected device. There are a couple of modes where you can mute the MIDI input if you wish, and Intech suggest that all sorts of things may be possible in future firmware updates.



## Blackstar St James Plugin EL34 & 6L6 Editions Amp-modelling Plug-ins

Back in *SOS* October 2023 we ran a review of the Blackstar's St James Plugin (<https://sosm.ag/blackstar-st-james-plugin>), which included both EL34 and 6L6 variants of the amp along with a library of virtual stompbox effects and alternative cabinet/miking options based on Blackstar's CabRig technology. As a quick refresher, these amp models are not slavish recreations of their St James amplifiers but, rather, have been optimised to perform at their best in a plug-in environment — that said, they do capture the essential character of those amplifiers. Similarly CabRig is not an IR snapshot-based cabinet emulation, but rather a modelled solution that reacts dynamically.

These new releases, which are available separately, are essentially stripped back versions of the original Blackstar St James Plugin. They incorporate the exact same amp models, but offer no stomp effects and your cabinet and miking options are much more limited, the only options being to switch the mics on- or off-axis and adjust levels and pans. Each amplifier, which also includes reverb and essentially three voicings, can feed two cabinets. Tabs allow the amp and cabinet sections to be bypassed individually, which means you can use the amp with third-party cab simulation plug-ins or you can use its cab simulation with other amp plug-ins. The noise gate of the original plug-in is retained, as is the tuner.

As I observed in my review of the original, the sound, sense of low-end weight and touch responsiveness of these amplifiers is impressive, between them covering a lot of tonal ground, from clean, via a mildly driven bluesy sound, right up to fairly aggressive rock. The EL34 version is particularly satisfying if blues and classic rock are your go-to genres, whereas the 6L6 has a more focused edge that works well with super-clean sounds or, at the other extreme in conjunction with your favourite dirt pedal, metal and heavy rock. Both amps pair well with drive pedals, and as most of us have access to delay, reverb and modulation effects, adding further treatments shouldn't be a problem. Despite the more limited miking options, I didn't



■ The Blackstar St James Plugin 6L6 edition.



■ ...and the EL34 version.

feel the urge to seek out alternative cabinet arrangements — the curated options (1x12 and 2x12 for the EL34, 2x12 and 4x12 for the 6L6) seem well chosen, with one cab delivering the weight and the other the bite, so there's a lot of tonal scope simply by adjusting the balance of the two. If that isn't enough, you can always add some parametric equalisation from one of your existing EQ plug-ins.

As with the 'full fat' version, these two plug-ins had me really enjoying the playing experience and also the immediacy with which I could dial in the sounds I wanted. In particular, the sense of low-end weight combined with biting but never-too-gritty highs really impressed. The two power-tube variants cover the ground that you might expect Marshall and Fender to occupy and, as I commented in the original review, I found more to like here than in many of the competing products that offer you dozens of amplifiers and a whole store full of pedals. If you have a clear preference for one of the amp types and you feel you have your effects bases well enough covered already, then this option to purchase the amps individually is very attractive. However, if you want both, then the full St James suite is the way to go — you get all those extra cabs and a set of pedals for around the same price as buying both amps separately. *Paul White*

£ Original St James Plugin £129.  
St. James EL34 and 6L6 £69.99 each.  
Prices include VAT.

W <https://blackstaramps.com>

## Inorganic Audio Liquid

### Granular Effect Plug-in

Liquid is described as a 'live granular effect' and, in common with other granular processors, it buffers the input, then extracts small sections or 'grains', each of which is then looped individually. These grains of audio may then be modulated and/or pitch-shifted in various ways, and in this instance we're informed that some of the equations used are based on fluid dynamics, which results in the creation of liquid-like movement. AU, VST and AAX formats are available (macOS and Windows), and authorisation is through a user key that allows the plug-in to be run on up to three computers.

As the various parameters are adjusted, the background pattern of grains, which are represented by small dots, moves to reflect their motion and stereo position. There are relatively few controls, with just 11 knobs and one Freeze button, so there's no steep learning curve. Unusually, there are no user presets to get you started, but it's so easy to come up with something of your own that this really isn't an issue. As you'd expect, all 12 parameters can also be automated from the host DAW.

The Movement control adjusts the degree of movement in the fluid dynamics simulation, and this in turn modulates the pitch and pan parameters of individual grains. Turbulence adjusts how the speed of each grain affects its pitch — at higher turbulence settings you hear a kind of lo-fi pitch wobble. Speed is a global setting that controls the playback speed of all the grains and it

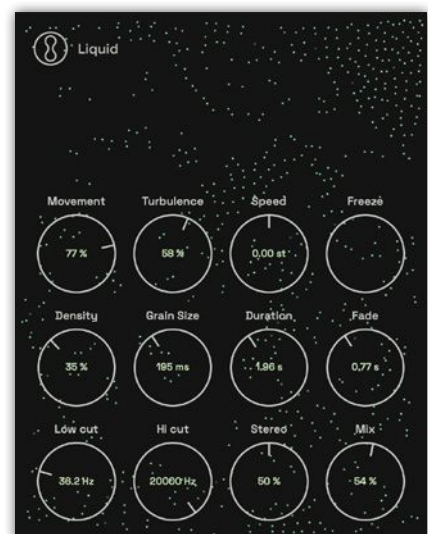

can be adjusted from -24 to +24 semitones, but this value also can be fine-tuned if you hold down Shift. Freeze is an on/off button, freezing the envelopes on all the grains and preventing new grains from being created, producing a continuous sound.

Density sets how many grains coexist at any one time, so small values lead to more glitchy sounds and large values to smoother sounds. Grain size sets how long newly created grains are but this setting also has a subtle in-built random factor. A smaller grain size equates to a shorter loop, in which case Duration determines how long the grain playback loops for before it fades out. Fade affects both the fade-in and fade-out times of grains so, again, longer times lead to smoother-sounding results, especially with non-percussive source material. There are also adjustable low- and high-cut controls to tailor the end result, a master Stereo setting that controls how much pan is added to each individual grain, and the expected wet/dry mix knob.

The kind of effects on offer here range from deep and grumbly to high and shimmering or, sometimes, a hint of both at the same time. Meanwhile, the modulation gives the sound an organic sense of motion and complexity. I found treatments that worked well on whole mixes and on single instruments, and piano-like sounds make good candidates for experimentation because you can then really hear what the grains are adding. If any trick has been missed, I'd say it's that there's no option to reverse the grains or to apply random octave shifts to them. But while the effects on offer are not as wide-ranging as from something like Output's Portal or Unfiltered Audio's Silo, there are still plenty of worthwhile treatments to be had, from warm and flowing to fractured clusters and shimmers. Worth checking out. *Paul White*

£ \$69

W <https://inorganic.audio>

## Old Blood Noise Endeavours Beam Splitter **Multi-stage Distortion Pedal**

Just when you thought it had all been done with distortion and overdrive pedals, Old Blood Noise Endeavours have put a new spin on the concept by putting three different overdrives in the same pedal — and they can be running in parallel or split out to three separate outputs. Additionally, two of the 'voices' have variable delay times of up to 250ms, with the addition of a feedback control for creating multiple repeats. At short



delay times these delays can also create some useful comb-filter effects, with the Decay knob controlling the resonance.

Although the pedal's front panel looks quite busy, it's not that hard to get your bearings, as the three main sections are identified by different coloured knobs. A further white knob, Deviate, adds a random modulation to the two delays. On the rear panel is a PSU input (9V, centre-negative), an input jack and three output jacks. Main is for the mixed output, though if you also plug into the other two all three jacks will carry the separate distortion stage signals. An Exp jack on the left of the case can be used to control the degree of deviation from a connected expression pedal.

The purple-capped controls adjust a hard-clipping overdrive, the strongest of the three stages. This has controls for Gain as well as Volume and Tone (treble roll-off), and the EQ changes according to the amount of drive you've dialled in. A softer distortion is available using the green section's controls, this stage employing both hard- and soft-clipping. This runs from almost clean to a moderate drive with some lows rolled off to stop the sound getting muddy. The delay section has Time and Decay (Feedback) controls in addition to Gain, Volume and Tone. To the left is the blue section, which controls a transistor overdrive that has a toggle switch for the

two gain settings. The Volume and Tone controls do as expected and again there's a delay stage with Time and Decay controls. This stage is described as being the most natural-sounding and reactive of the three.

Checking out the purple section first, this goes from moderately dirty to almost fuzzbox ferocity, with the Tone control offering plenty of range, from soft and soupy to seriously biting. The green section is not quite so aggressive but still retains a raunchy, gritty edge that sounds more ZZ Top than Gary Moore. As promised the blue stage is the most touch responsive, though the use of a Gain switch, rather than a rotary control, is a little frustrating as I would have liked to hear it at even lower gain settings.

The big idea here is that, by adjusting the delays and balancing the three sections, you can create the illusion of multitracking. Combining the three sections while introducing some delay in this way does indeed create a very big sound, and it's one that in my view would suit heavy rock rather better than it would classic rock. The Deviate controls adds a kind of random LFO modulation to the delays, which enhances the illusion of multitracking, and there's also a lot to be explored by



offsetting the three sounds by very small amounts as that introduces tonal changes caused by comb-filtering when the sounds are combined in mono. This trick works just as well with synth lead sounds as it does with guitar. In fact, more generally, while distortion is often thought of primarily as a guitar effect and the Beam Splitter does of course work very well in that context, it can be put to good use with synths or drum machines.

To summarise then, there's a lot to explore here, whatever the sound source, and it can be very effective. But this is a pedal unlike most others, and would suit those with an experimental outlook better than to those who are searching for the ultimate natural-sounding guitar overdrive. *Paul White*

£ £229 including VAT.

E [sales@audiodistributiongroup.com](mailto:sales@audiodistributiongroup.com)

W [www.audiodistributiongroup.com](http://www.audiodistributiongroup.com)

W <https://oldbloodnoise.com>



## Vienna Symphonic Library Synchron Smart Orchestra VSL Synchron Player Instrument

★★★★★

Painstakingly programming an orchestral score one instrument and section at a time can be excruciatingly slow — by the time you get to the triangle part, you'll probably have lost the will to live. Fortunately, there is an easier way: VSL's new Synchron Smart Orchestra (20.17GB installed) takes the donkey work out of MIDI programming by providing pre-orchestrated tutti ensembles, percussion, choir, harp and a suite of lead instruments in one convenient package.

Not to be confused with Vienna Smart Orchestra (recorded in VSL's Silent Stage studio space), Synchron Smart Orchestra was entirely recorded in the large hall acoustic of the Synchron Stage. The ensembles and percussion are taken from existing VSL libraries Synchron Duality Strings, Big Bang Orchestra Altair (brass), BBO Neptune (woodwinds), BBO Ganymede (choirs) and Synchron Percussion I, while the flute, oboe, clarinet and trumpet solo instruments are all-new recordings specifically created for this product.

There are two main presets: 'Tutti' features a keyboard split of ensembles in the C2-C6 range with unpitched percussion mapped to D6-C8, while 'Tutti & Solo' substitutes a choice of solo instruments for the percussion. You can also play the solo instruments over their full ranges. Both preset types come in three dynamic configurations which offer a choice of velocity or mod wheel dynamic control.

The tutti ensembles blend each orchestral family into a single playable unit with instruments voiced in octaves, creating a set of classic orchestral textures: at the low end, ominous octave cellos and basses, blasting trombones and tubas and the menacing low growl of contrabassoon and bass clarinet, with the high register handled by octave violins, trumpets and French horns, three flutes and a piccolo. All ensembles play long and short notes, and the strings also perform tremolo and pizzicato styles.

SSO's ensembles are augmented by a mixed-voice SATB choir of 48 singers singing the immortal lyric 'ah' and a great set of timpani played with medium mallets. Also included are the beautiful Synchron



harp and a very pretty celeste, with the aforementioned percussion hits and rolls covering orchestral essentials. The icing on the cake are the seven legato instruments' long notes, tailored for melodic work. For string top lines there's an ensemble of 14 violins, while 10 cellos work a treat for emotive midrange melodies. The solo woodwinds, trumpet and French horn are also excellent, perfectly in tune and a pleasure to play.

Put this all together and you'll hear some wonderful rich timbres. My personal favourite is the 'Orchestra + Violins' combo, a perfect vehicle for heart-stirring romantic themes; add the choir, and you have instant lavish, large-scale musical drama. The beauty is that all possible combinations are available within one preset, courtesy of VSL's ingenious keyswitching system. A great tool for sketching, and an inspirational set of sounds. *Dave Stewart*

€245  
www.vsl.co.at

## Sample Factory Saturn Hybrid Piano Kontakt Instrument

★★★★★

Saturn Hybrid Piano is the debut plug-in from Sample Factory. It's available as a Kontakt instrument (full version of Kontakt 6.7.1+ required) and is distributed by Big Fish Audio. It needs around 9GB of space and 8GB of RAM.

The primary sound is sampled from a Kawai GX grand piano using quality condenser mics. There are three levels of velocity (somewhere in the region of mp, f and ff) with four round robins each. Articulations include regular sustain, pedal down sustain, staccato and reverse. There is the option to layer in synth pads and alter the sound with various effects and filters to create some very unique patches.

The design is a single-page layout featuring seven sections. A drop-down menu containing 160 presets (and 40 user spaces) can be found at the top of the GUI, starting with basic pianos and finishing with effected sounds.

## SAMPLE LIBRARIES

To the left is the synth pad section, with 24 samples taken from the Moog Grandmother and Roland Juno-60, a filter, mixer and ADSR controls. An optional staccato section transforms the pad to more of a synth stab, plus you can reverse the samples for some interesting note endings.

The central panel houses the 10 effects with four effect slots available. Mouse-over and drag vertically to control the level of each. Selecting the gears icon opens further panels for fine-tuning.

You can link effects by clicking the icons below and selecting the MOD button top right. Two faders appear that allow you to bring them in one by one when using the horizontal, or equally across the whole selection when switching to the vertical. Assigning a controller to a fader allows for some great performance options.

Next is the LFO panel, with Volume, Pan, Pitch, LP, HP and BP options. Choose any combination of these filters and fine-tune each using their individual parameters. Each

has four available waveforms, with a width control for the square wave. You can modulate the sound even further using the step sequencer. Up to 16 steps can be

drawn in with the mouse (half note to 32nd note) for each of the modulation effects. As with the LFO panel, switch each one on individually and then select by name to fine-tune the tempo and mix.

To the right is the Dynamics panel, containing controls that affect the piano sample only. Limit the dynamic range, slow the attack rate, change the envelope shape and fine-tune with a three-band EQ containing HP and LP filters. Manipulating these filters can give you sharp, bright tones through to a nice felt-piano effect.

Despite being primarily based on a piano sample, this plug-in offers numerous options and was really inspiring and enjoyable to use. There could be multiple uses for it across a wide range of musical genres. *Atheen Spencer*

\$79.95  
www.bigfishaudio.com



RT Sonics

## Signature Strings WAV



The double bass is at the heart of Signature Strings, the latest release from audio library company RT



Sonics, which features over 270 designed and source sound effects. Aimed at video editors, music composers and sound designers, the library is especially suited for Hollywood-style music production, with a wide array of options designed to create maximum impact. An offering of whooshes, pings, braams, risers, low booms and percussive hits indicates that the library speaks a modern and cinematic language, conveying emotion and excitement at the source level itself.

Even a quick first listen makes it immediately clear that you're dealing with a top-notch recording and production setup. The sounds are impactful, evocative, and well balanced — the booms land, the transients punch through, and the ambiences evolve, building anticipation and tension. The literature informs us that all source sound effects were recorded with high-end professional equipment, including a Sound Devices MixPre6 MKII, Sanken CO-100K, Rode NT5, and DPA4060, to name a few.

RT Sonics was founded by a sound designer (the award-winning Rostislav Trifonov) and this is reflected in several details that make the library a pleasure to use. For instance, while the dynamics of the library range from soft to loud, they can all be auditioned at a comfortable level, without constantly adjusting the volume knob; you won't accidentally create a jump scare for yourself because you play a loud effect immediately after testing a more mellow one. The second detail that is useful is that the sounds provide leeway with tails — there's nothing worse than a too-rapid decay on a sound when you need just another beat for a smooth fade out. Even shorter sounds like impacts and hits allow some room at the end of the sound for a transition.

What is also noteworthy is the library's ease of use, which starts with the format itself — all sound effects are delivered via digital download as WAV files, with a resolution of 24bit/96kHz for the designed SFX, and 192kHz for source SFX. The WAV format makes it application/

software-agnostic and you can start using the library straight away without the need for any further downloads or installations. Another factor that contributes to ease of use is how well-organised the library is — each individual file contains multiple variations of a type of sound. This speeds up the process of auditioning sounds; if you change your mind, you just have to look within the file itself for another option. Metadata is meticulous and detailed, making for a smoother workflow.

Sound designers are spoilt for choice when it comes to effects libraries but what makes Signature Strings stand out is that it offers an imaginative and expressive pack of sounds, and top-quality production at an affordable price. Highly recommended.

Sonal D'Silva

**\$59**

[www.rtsonics.com](http://www.rtsonics.com)

## FrozenPlain Deep Conjuring Plug-in Instrument



Powered by the free Mirage player, Deep Conjuring, created in collaboration with Beautiful Void Audio, is inspired by dreams, both peaceful and deeply disturbing. Its content is equally useful whether working on a horror sound score or a relaxation project. FrozenPlain describe the sounds as sitting on the edge of the synthetic and the organic, which I think is a pretty fair description. For those unfamiliar with Mirage, it is a (VST/AU but not AAX) sample-based synthesizer allowing up to three different sounds to be layered. Each layer can be adjusted for pitch, volume, pan, filter, volume envelope, LFO, EQ, sample loop settings and MIDI settings. Mirage responds to MIDI velocity and sustain pedal on CC 64, while any parameter can be automated using DAW automation. It is also possible to map parameters onto the knobs and sliders of a physical controller by right-clicking the target parameter, selecting 'MIDI Learn' then moving the selected controller.

Deep Conjuring is made up of 92 'instruments', some multisampled, others loops, that can be loaded into Mirage's three layers and then adjusted before being further processed via the 10 built-in master effects. FrozenPlain reveal that the

sounds were created using samples of things like harps, flutes, violins, rain, tornado sirens and soft synths, then processed via a convolution engine. We're also informed that the sample set is similar to Beautiful Void Audio's original Kontakt instrument, so if you already have that then you may not need the Mirage version. Then again, you may prefer the Mirage style of control.

Deep Conjuring's instruments are arranged into sections for ease of navigation and are listed as Circuit Bent, Dark And Heavy, Distorted Pads, Keys And Percussion, Motion And Movement, Soft Pads, Strange and Vintage/Lo-fi. These are arranged into 120 included presets accessed via the Mirage browser, which also includes a random preset loading function. Creating new sounds can be as simple as replacing the instruments in one or more layers with alternatives, or you can use the synth-style controls to tweak the envelopes, filters, modulation and so on.



Having reviewed a number of FrozenPlain libraries for Mirage, I have to report that the Mirage interface makes editing very straightforward yet still offers enough scope to make the most of the library's

core sounds. Exploring the Deep Conjuring presets reveals a breadth of dreamlike sounds, the more gentle of which would fit well into ambient music compositions while the more disturbing ones would be a good fit for horror and psychological thriller soundtracks. As always, the quality of the core sounds is excellent and good results can be achieved by layering these with other FrozenPlain libraries such as Frozen Reveries and Dreamstates. At the moment this means opening up two or more instances of Mirage, as you can't combine samples from different libraries in the current Mirage engine, but by using features such as Track Stacks in Logic Pro X, it is easy enough to layer multiple instruments. Given the very affordable nature of the FrozenPlain libraries and the intuitive Mirage interface, they have a lot to recommend them, and Deep Conjuring is a very worthy addition to the range. *Paul White*

**\$49**

[www.frozenplain.com](http://www.frozenplain.com)

Audio examples of this month's libraries are available at [www.soundonsound.com](http://www.soundonsound.com).



## Q When should I start mixing through my bus compressor?

I've been experimenting with mix-bus compression, and quite like the glue and punch that it can offer. But at what point in the mixdown process do you think it's best to engage the master-bus compressor?

Rick Moran via email

### Mike Senior, SOS Contributor

The main difficulty here is that there are two conflicting factors at play. First, inserting a compressor over your master bus will inevitably change your mix balance to some extent. For instance, it'll frequently boost low-level details such as instrument sustain tails and reverb/delay effects, and it might also cause strong drum hits and bass notes to duck lower-level signals. The earlier in the mix process that you fire up your master-bus compressor, the sooner you can start adapting your mix settings in response to these balance changes. Then there's the fact that the operation of a master-bus compressor will depend

on what you're feeding it with, and it's thus difficult to assess the suitability of your compression settings if you're feeding it with a mix that's incomplete. In other words, the later in the mix process you add the master-bus compression, the more effectively you'll be able to set up that compressor.

So for every mix you do, you'll have to make a judgement call that weighs up those two competing factors in relation to the unique demands of the music you're working on. For example, with an acoustic jazz track I might apply my master-bus compression right at the end, on the basis that the very gentle, low-ratio setting I'd be planning to use wouldn't appreciably impact any of the musical balances between the instruments, and all I might have to do is tweak my reverb return levels a little. But then with a heavy rock track, where I want to use ostentatious level-pumping compression on the master bus, I might introduce that master-bus processing

■ When you should engage master bus processors depends on the material you're mixing and what you want the processors to do.

quite early on in the mix, when I've built only the most basic skeleton of a dry rhythm-section sound — simply because I know it'll be pointless trying to judge the balance of any of the other tracks outside the context of that level-pumping. In that scenario, though, I'd probably have to revisit the master-bus compressor settings several times throughout the mixing process as the full mix sound developed.

It's important to realise that the mix and the master-bus compressor interact, so you can't compartmentalise the two things. The earlier you introduce the master-bus compression, the more time you'll likely have to spend fiddling around with the exact compressor configuration and settings; the later you introduce the master-bus compression, the more you'll likely have to adapt your mix settings in response.

In practical terms, what this means is that I'll normally introduce more dramatic master-bus compressor settings earlier in the mixing process, while leaving subtler ones until later. And this same rule of thumb carries over to other types of master-bus processing too. If I were multiband-compressing my master bus, for instance, I'd only ever be doing so for subtle detail enhancement, so it would make much more sense for me to add that late in the mix process. With things like tape emulation or tube saturation or anything similarly 'colouristic', I would normally only apply that quite subtly, so again I'd add that close to the end of the mix. However, on those few occasions where I've been deliberately mixing into some kind of character processing for a specific vintage/retro/lo-fi sound then I've sometimes inserted those plug-ins pretty much from the get-go, even though I may have literally only a couple of instruments in the mix.

## Q Should mixers have dedicated line amps or is padding the mic amp OK?

I'm restoring an old Soundcraft 600 mixer so have been reading up on it. It seems that for line-level signals it just pads them down and uses the mic amps. I've read some disparaging opinions about this way of doing things on the Internet, with purists suggesting it's better to have a dedicated line



amp, but I also trust that the Soundcraft designers designed it well! Does it *really* make a difference?  
**SOS Forum Post**

**Hugh Robjohns, Technical Editor**

The designers did a good job: the Soundcraft 600 was a good-sounding, cost-effective console that more than one *SOS* editor has enjoyed owning and using! I'm sure you've downloaded the manual, which is still available on Soundcraft's website, and this confirms that the line inputs are padded (30dB) to a high mic level and routed through the mic preamps. It's also true that where cost and size are not issues a separate line amp offers marginal technical and operational benefits. In the real world, though, cost and size matter to customers and manufacturers, so compromises are made. This particular approach is an extremely common and pragmatic arrangement, with negligible technical compromise: a high-end audio analyser might detect fractionally higher noise and THD than in a dedicated line amp but your ears won't, so it makes no practical difference in normal applications. There will be some other compromises in the console for the same reasons but, as I say, this is a good, well-designed console; if you prefer the purist approach, you'd be looking at paying rather more for brands like Neve or SSL. **///**

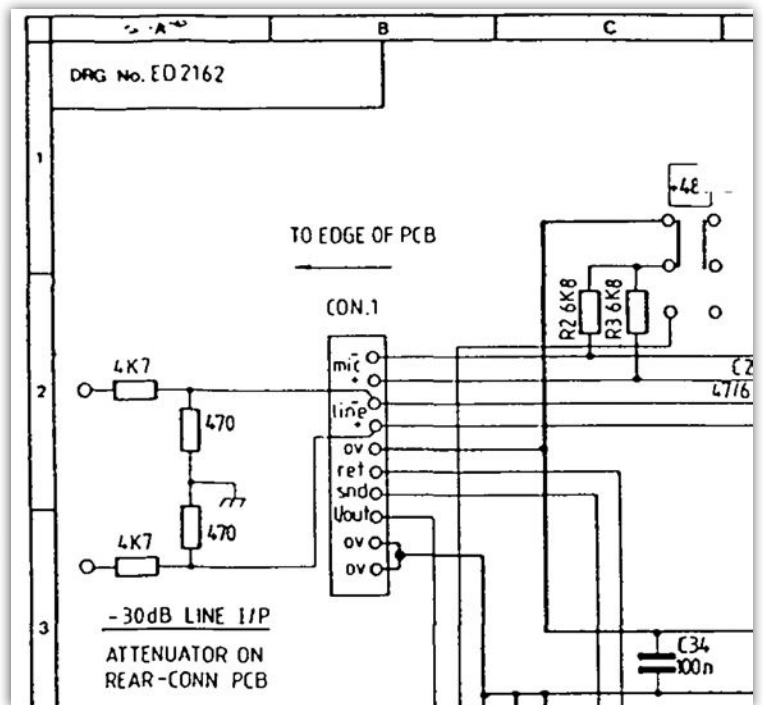

The Soundcraft 600's padding of line-level sources so they can be run through the mic amps, as indicated in this excerpt from the manual's block diagram, is a common and pragmatic arrangement — and really not as big a 'problem' as some purists may suggest!



# SUBSCRIBE & SAVE

TABLET | WEB | REPLICA | PRINT



- Go **DIGITAL** - get 12 monthly Tablet issues + all locked Web articles + monthly Full Issue PDF download the day the issue goes live.
- Go **PRINT+DIGITAL** - get the best of both worlds and save over 50%.\*

## 1 ICONIC MAGAZINE

### 6 GREAT WAYS TO READ IT

TABLET - PHONE - WEB - PDF - REPLICA - PRINT

*All this for less than the price of a Coffee+Pastry each month!*

**iOS / ANDROID**  
 Every Digital sub includes a 5-device licence to our App: mix and match across iOS/Android Tablet and Smartphone.

**ONLY READING SOS IN PRINT?**  
 Choose our full Print+Digital bundle for unlimited 24/7 access.

[www.soundonsound.com/subscribe](http://www.soundonsound.com/subscribe)

\* The 50% discount offer is based on the UK retail price of the Print magazine, Tablet and Web subscription when sold separately. Subscriptions can be cancelled at any time and you will receive a pro-rata refund for all outstanding issues.



## You already have all the tools you need to mix in Atmos, so why not give it a go?

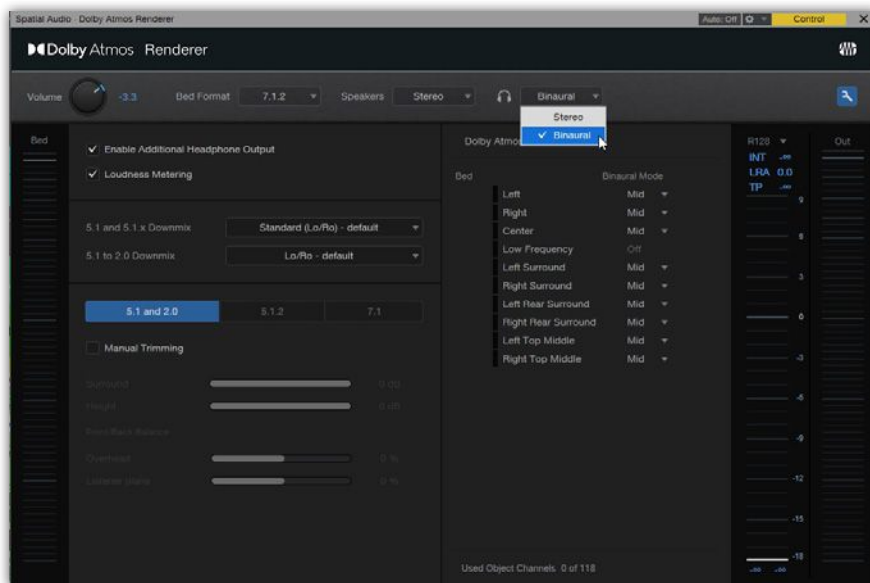

ROBIN VINCENT

If you're anything like me, you'll have been ignoring Dolby Atmos because it feels complex, and you don't think it really applies to you. Besides, there's no way you're about to install 17 speakers into the cupboard under the stairs where you make your music. But Studio One 6.5 has gifted us with a fully fleshed-out Dolby Atmos rendering environment, so the least we could do is give it a look. And, as luck would have it, it's entirely possible to experience Atmos through a pair of regular headphones, and the whole process is remarkably simple. So, let's get binaural!

First, open a song that you fancy sprinkling with some of that spatial magic. I would recommend saving it as a new song, because you're probably going to be messing it about quite a lot.

In order to prepare Studio One for the rigours of Atmos mixing, there are a few things we need to take care of. Now, you would imagine if we intend to mix in 7.1.4 or such like, then we're going to need a bigger audio interface to handle all the outputs. That's true for mixing on monitors, but if we just want to mix binaurally on a pair of headphones, then all we actually need is a stereo output. We can fool Studio One into using lots and lots of outputs even though they don't actually exist.

So, go into Song Setup (shortcut Ctrl/Cmd+) and on the General Page, click the Spatial Audio tab. Under Mode, select Dolby Atmos. It will probably throw in a Bed Format of 7.1.2 and an Output Format of 7.1.4.

The Atmos Renderer, configured to output binaurally through headphones.

7.1.2 is the 'standard' Dolby Atmos setup, comprising of seven surround speakers, one subwoofer and two ceiling speakers. You should set the Output Format to whatever your speaker situation is, although, as we're going to be doing this on headphones, it doesn't really matter. Click on Apply, but don't close the window just yet.

The sample rate will default to 48kHz. For Atmos, you are required to run the audio at 48kHz or 96kHz. You also need to set a buffer size of 512 or 1024 samples respectively. This ensures the system has enough slack for glitch-free spatial mixing. To get to your audio interface settings, click on the Options button in the bottom left and go to Audio Setup.

Back in the Song Setup window, go to Audio I/O Setup. If your audio interface has enough outputs and you select 7.1.4 as the output format, then all the connections will be mapped out for you. However, all we need is a headphone output. You can add a separate one, or use your main output, depending on how your audio interface is configured. The important thing is to remove any of the surround connections, assuming you don't actually have a 7.1.2 system.

### Return To Render

When you go back into your song, you should see the Dolby Atmos Renderer window come up looking splendid. You may also notice some other things have changed. All the channels in the mixer have circles where the panning used to be, and

a Renderer channel has appeared over by the main output.

Let's make sure the Renderer is doing what it should before we start spinning our guitar around our heads. Click the little spanner icon on the top right to reveal some settings. If you've created an additional output for your headphones, then you need to tick the Enable Additional Headphone Output box. Close the settings and set the Output or the Headphone output to Binaural. Put your headphones on, and we are now ready to experience the awesomeness of immersive audio.

Hit Play on your song and try switching between stereo and binaural in the Renderer. To me, in binaural mode, it sounds like everything is piled on top of my head, and so we need to embark on a bit of panning.

Studio One initially assumes that everything should be mixed to the bed track (which it refers to as Surround Panning) rather than being treated as an object (which it calls Spatial Panning). In reality, you might want to do a bit of both. Anyway, let's start with Surround and see where that gets us.

### Surround Vs Spatial Panning

Instead of standard left/right panning, we can now move sounds all around us. If you double-click the small circular panner on a soloed channel strip you'll open the Surround Panner GUI. Here you can move the position of the instrument relative to your head in the middle. In the bottom section, you can also adjust the height in a sort of dome. If your instrument



The Surround Panner.

was originally recorded to a stereo track, then you have control over the spread of that stereo source, and also its size in the space.

It's interesting to watch the beds in the Renderer show which speakers your sound source is hitting as you move it about. The representation in the headphones is debatable. If you switch between stereo and binaural

there's certainly a marked difference in how it sounds. But, personally, I'm not really perceiving things as being behind me. There's something about height panning which is interesting, though.

To swap into Spatial Panning, right-click the panning circle or click the little down arrow next to it and select Spatial Object Panner. Now, this is what we're here for. It's instantly 'different' to my ears. The circular panner has been replaced with a square one. While the idea of moving the object in both the horizontal and vertical planes is the same as Surround, the difference is remarkable. You may also notice that your instrument is now represented in the Renderer as a single ball (or two balls if it's a stereo track) and no longer appears in the bed meters. Your instrument is now generating sound from a point, rather than being nestled into the beds of surround.

As you move it around, you can view the object from various angles in the Renderer. This gets very useful as you inject more and more instruments and tracks as objects. With a handful of objects placed about in space, I get a really satisfying sense of space and immersion purely on my headphones.

## Deadly Spins

You can automate the spatial panning parameters just like anything else in Studio One. But there's one particular thing we need to get out of our system before we can take Atmos mixing seriously: spinning an object around our head. Doesn't matter

who you are, or how many years of serious audio engineering you've sunk into your music-making, this is something you will inevitably find yourself doing at some point. And you should; it's fun and potentially a genuine audio effect. So, I thought I'd take out some of the guesswork and show you how to do it, so that we can all move on with our lives.

You can, of course, simply switch the Object Panner into automation write mode by clicking on where it says 'Auto: off' at the top left, and then move the object about with your mouse during playback. Studio One will obediently capture and automate that movement for you, but it's unlikely to be a nice fluid spin around your head unless you have a joystick controller and some expert fingers. To do it properly in a circular fashion, we need to draw in some sine waves.

Select the track you wish to spin in the arrange window. Either right-click and select Show/Hide Automation and then click Add/Remove from the drop-down menu, or find the same drop-down menu in the Inspector panel. Under the Audio section of the parameter list, add across Pan X and Pan Y; you can add Pan Z for good measure if you wish.

Open up the automation lanes under your track by clicking the tiny little sine wave button in the bottom left of the track header. Create a loop around a few bars to play with. We're going to be drawing some sine waves, so you'll need the Sine tool from the Pen menu in the toolbar. The

size of the sine wave automation is dictated by the snap and quantise settings. For a not-too-crazy spin, I'd go for a quantise setting of half a bar. Click and drag in the Pan X automation lane to generate a line of perfect sine waves. On playback, this will create a nice left-to-right or side-to-side panning effect. Now, do the same on the Pan Y track. You'll find that your object is flying diagonally from corner to corner. To get it to move in a circle we have to unlock those dim memories of school trigonometry and offset the sine waves by 90 degrees. To do this, set your quantise to a quarter bar, use the Range tool to select the Pan Y automation, and shift it to the right a quarter of a bar. Hit Play and enjoy the effect of your chosen track spinning around your head — fabulous.

You can use the Transform tool to adjust the height of the sine waves to set how far away the spatial object is. I'd also recommend setting the quantise to a bar and adding a sine wave to Pan Z for a nicely immersive experience.

## Be Immersive

That's more or less all there is to it. When you export your mix, don't forget to use the Export Spatial Audio option; Studio One will then generate all the necessary files.

One last note is that you'll see a Binaural Mode setting next to each bed and object. These are distance indicators that help the Binaural rendering emphasise how far away things are. Experiment with them to get the best results in your headphones. **///**

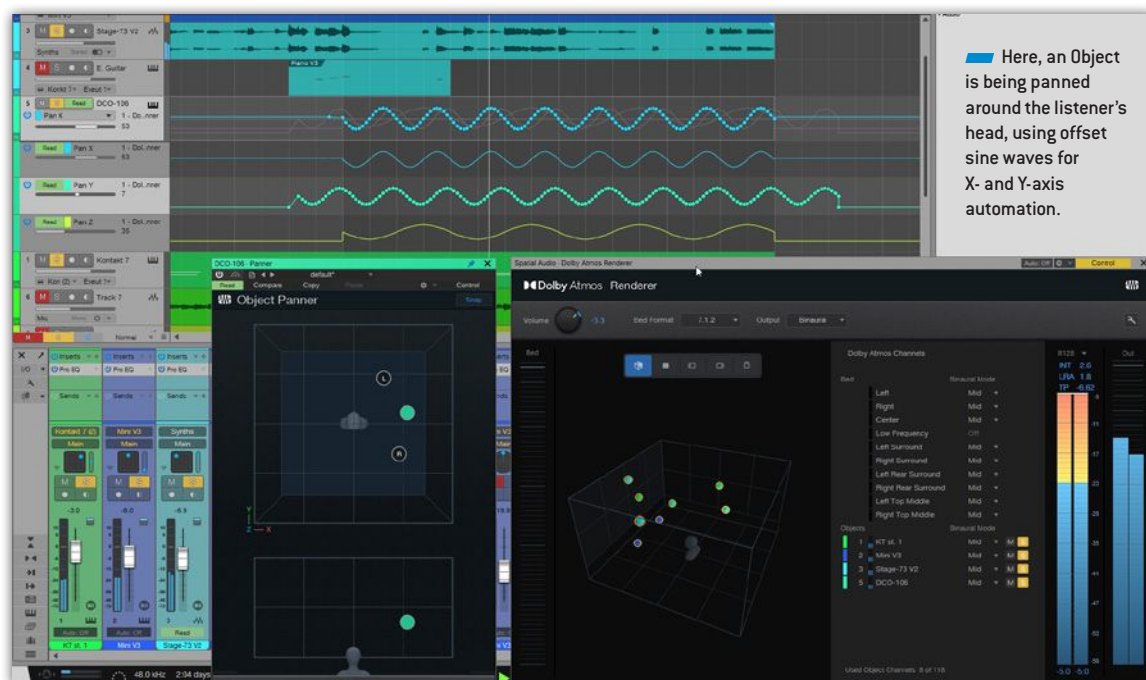



## We explore the many options for controlling Pro Tools with hardware.

JULIAN RODGERS

The options for hardware control of audio plug-ins in Pro Tools are different from those available in other DAWs, particularly when it comes to using MIDI. Considering the ubiquity of MIDI controllers and the well established convention of assigning on-screen controls in a DAW, it often comes as a surprise to new users of Pro Tools that you can't just right-click an audio plug-in's controls and select 'MIDI Learn'.

### Plug-in Parameters Vs DAW Controls

It's important to draw a distinction between plug-in parameters and DAW controls. There have been proprietary solutions available for many years to control things like faders, pans and sends. The Pro Control surface, released in 1999, introduced dedicated, deep control of Pro Tools from hardware via an Ethernet cable and the DigiNet control protocol. That technology reached its final and most capable iteration in the ICON series of worksurfaces. The D Control and the smaller D Command were excellent too, and popular in the market they were designed for.

After Avid announced their acquisition of Euphonix in 2010, the EuCon protocol became the primary connection format for deep control of Pro Tools, and it remains so to this day. The current generation of EuCon controllers are powerful and scalable, ranging from the free Avid Control app, through the extremely popular S1 and Avid Dock, to the big-ticket S6.

Pro Tools does still offer mix control over MIDI. The venerable HUI protocol, which is based on standard MIDI messages, is an option, though it is showing its age, launched as it was in 1997. That said, Neyrinck's V-Control system still makes good use of it.

If you look in the MIDI Controllers tab of the Peripherals window in Pro Tools, you'll see the almost-as-old Command 8 listed, though the Reference Guide warns that the driver is only installed with Pro Tools 10. Likewise, M-Audio Keyboard is an option; this dates back to the days when Avid owned M-Audio, and I remember feeling

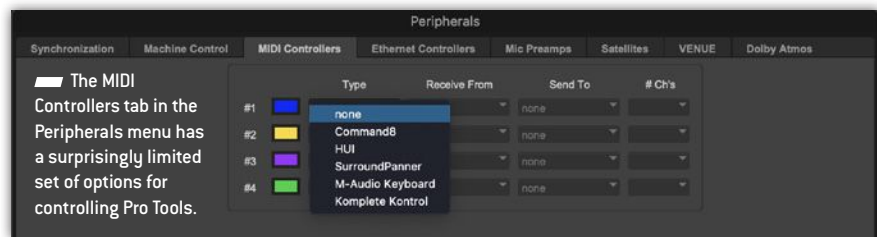

very pleased setting up my M-Audio Axiom controller to control the Pro Tools transport. The age of the products referenced in this list would suggest that MIDI control of Pro Tools has been abandoned in favour of the much more capable EuCon if it weren't for the inclusion of Native Instruments Complete Kontrol, another MIDI-based option, which was added in 2021. Complete Kontrol gives hands-on access to Pro Tools features like fader levels, transport and more, but the focus is firmly (and understandably) on control of software instruments within Pro Tools.

### Plug-ins Vs Instruments

This introduces an important distinction between virtual instrument plug-ins and audio plug-ins. It has always been possible to access virtual instrument parameters using a standard MIDI controller in Pro Tools. So for example, you can open Xpand! 2, right-click on the filter cutoff, enter MIDI Learn mode and, by turning an encoder on your MIDI controller, assign that MIDI CC to that on-screen control. There are a handful of audio plug-ins which can access this MIDI Learn functionality too, principally Avid's guitar stomp effects, which originally shipped with the Eleven Rack hardware. These process audio but unusually (for Pro Tools) can be controlled using MIDI. It is reasonably straightforward to assign them to any MIDI controller. A MIDI track has to be created to receive incoming MIDI, and that MIDI has to be routed to the plug-in via the MIDI Out of that MIDI track. This isn't possible for conventional audio plug-ins in Pro Tools.

It is also possible to control FabFilter plug-ins with MIDI, using the same method as with the guitar effects. It should be borne in mind that standard MIDI messages are too coarse to accurately control things like EQ frequency, having a resolution of only 128 increments. FabFilter are the only third-party plug-ins I've personally encountered that can be controlled in this way, though there may be others.

If you want full control of Pro Tools, then, the depth and power of EuCon is hard to beat. Having tried most of the alternatives,

my S1 is the only solution I've enjoyed using enough for it to compete with the familiarity of a mouse and keyboard. If you want customisable control over Pro Tools, including the ability to create macros and semi-automate aspects of the software, then SoundFlow is very much worth investigating. Pro Tools Ultimate and Studio users who have a current subscription qualify for a free SoundFlow Cloud Avid Edition until March 2025.

But it's still the case that there isn't a freely accessible, convenient way for Pro Tools users to set up quick, ad hoc mapping of Pro Tools plug-in parameters to MIDI controllers. This kind of often temporary mapping is extremely convenient, and while there isn't a free solution, there are some third-party offerings that can really help.

### On The Fly

Owners of Audient's iD series of audio interfaces have access to a very useful feature called ScrollControl. This allows the encoder on the interface to control whichever control is currently under the mouse cursor on screen, including plug-in parameters, and can be used to write parameter automation in real time. It can't control track faders in Pro Tools, but you can work around this by using Trim plug-ins and automating those instead of the fader. I assume ScrollControl simply sends mouse scroll-wheel data, and as Pro Tools faders can't be controlled with a scroll wheel, they can't be controlled using ScrollControl either. (SSL's UF-series controllers have a similar capability.)

I first came across this kind of 'touch and twist' control on DiGiCo digital mixers, and the zero learning curve it brought to an unfamiliar console is just as useful in Pro Tools. There is a similar control available in EuCon since version 2022.4. Available on the S4 or S6, the EuCon Assignable Knob feature achieves exactly the same functionality, and can be controlled either from a dedicated encoder on the surface or mirrored to the large jog wheel. Its presence on Avid's flagship EuCon surface proves the point that even with

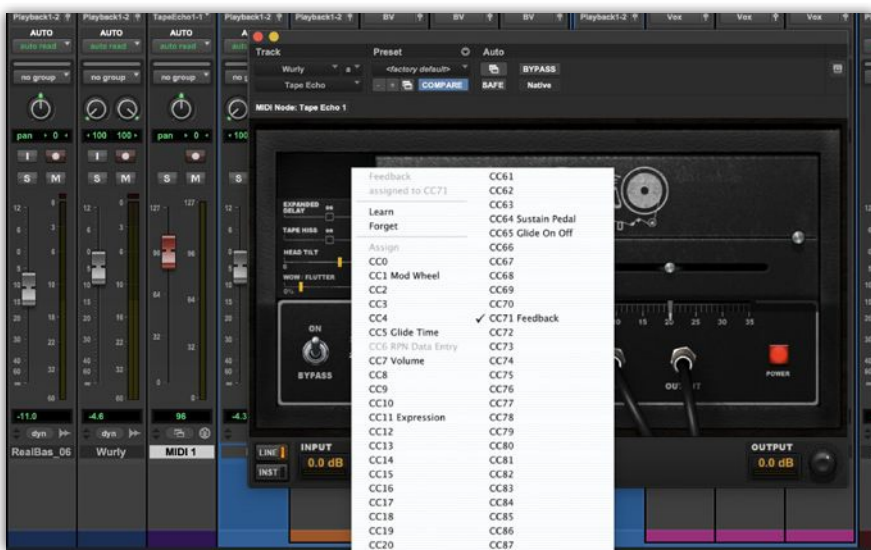

Only a select few plug-ins have a MIDI Learn feature. These include Avid's guitar-based effects (which originally shipped with the MIDI-friendly Eleven Rack hardware), and FabFilter's plug-ins.



the deepest of configurability there is still a place for on-the-fly mapping. This Assignable Knob feature is also available on the Avid Dock, where the Monitor knob can be reassigned in EuCon Settings to function as an assignable knob, and again be mirrored to the jog wheel.

So what other methods are there for controlling plug-in parameters over MIDI? Two third-party controls come to mind, both of which offer quick-to-set-up MIDI control of plug-in parameters in Pro Tools.

### Mulligan & CS Control

Mulligan is an application from reFuse that offers a flexible approach to plug-in control. It makes use of the M-Audio Keyboard

option in the Peripherals page as a route into Pro Tools, and is both quick and easy to use. It offers default plug-in maps, which

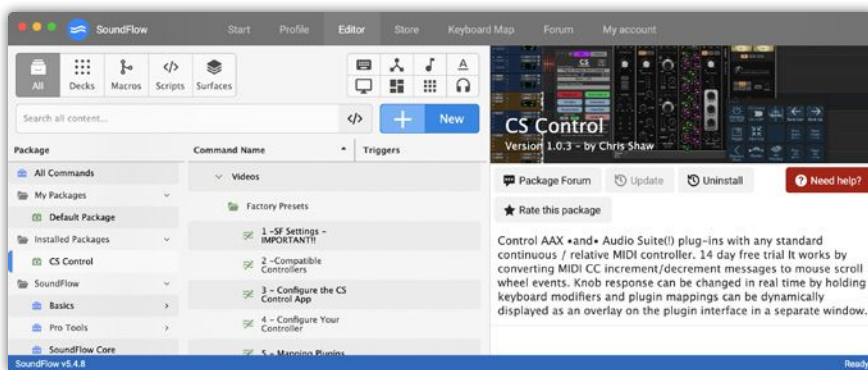

CS Control, a Package for SoundFlow written by Chris Shaw, allows for comprehensive MIDI control mapping.

are displayed in banks of eight on the HUD (a bar at the bottom of the screen which shows current assignments), and also offers transport control. Custom mapping is also available, so there's no compulsion to learn a preset assignment map.

CS Control is a Package for SoundFlow written by Grammy Award-winning producer and engineer Chris Shaw. SoundFlow is a platform on which anyone can create, share or sell Packages. One of the nice things about SoundFlow is its community feel, and well-known engineers such as Chris and Andrew Scheps are very active SoundFlow users. CS Control achieves similar results to Mulligan but using different means. Consistent with its SoundFlow roots it is very customisable and doesn't offer presets, but mapping is extremely quick and, rather than using a HUD panel, it offers a plug-in UI display window with mappings displayed on it. CS Control can also control AudioSuite plug-ins.

Something to be aware of is that, for reliable performance with either of these solutions, your MIDI controller has to output relative MIDI values. Most MIDI controllers with endless encoders (rather than knobs with end stops) output relative data, but not all. Absolute data will result in jumps and glitches in performance when used with these products.

Whether you're recalling carefully set up controller mappings or quickly setting up a mapping as and when you need it, physical control of plug-ins can be very beneficial to the mix process. Whether you're finding the sweet spot between resonance and cutoff during a filter sweep, or adjusting input and output on an 1176 simultaneously, the benefits of such immediacy can be transformative, and if you're not yet ready to buy into EuCon hardware, software options can provide a very useful alternative, even for Pro Tools users. ■■■



## The revamped Chord Pads offer even better support for songwriters than before.



JOHN WALDEN

Cubase's Chord Pad facility has always made experimenting with different chords easy for anyone, regardless of their version of Cubase (it's included in the Pro, Artist and Elements editions) or their level of keyboard competence — you can create (or load) a palette of suitable chords, which can be as simple or as complex as you like, pick a key, and then all you need to experiment with different chord sequences is a single finger. Thus, it can be a very powerful aid to songwriting... and Cubase 13 brought some interesting refinements that are aimed squarely at this use-case scenario.

### Strike The Right Chord

As shown in the first screenshot, the Chord Pads can be accessed in the Project window's Lower Zone. At its simplest, you can use the pads, each of which is associated with a MIDI note, to trigger a full chord on the currently active MIDI/virtual instrument track. However, you can now specify a larger number of pads (configured in the Chord Pads Remote Setting dialogue box, accessed using the MIDI connector icon located top right). You can also opt for a grid-based layout (in the Chord Pads Display Setting dialogue, accessed very top right), which may be helpful if you are using a drum-pad-style device to trigger your chords.

The top bar menu system has been reorganised to provide better access to options for transposing or re-voicing chords on selected pads. There are also improved pattern performance options (very neat, but a topic for more detailed consideration another day...) and options to configure both

how chord triggers are quantised and how note overlaps are handled.

Steinberg have added a bunch of new Chord Pad presets that are well worth exploring but it's easy to build your own selections, and we will look at one songwriter-friendly route for doing this in a moment. Before we do, I want to offer you a quick reminder about the Adaptive Voicing (AV) feature. In essence, if this is active when you trigger chord changes, then Cubase will attempt to make those changes smoother by using the smallest shifts in pitch required to move between chords — much like a competent piano or guitar player might do. This can be activated on a per-pad basis using the AV buttons in the toolbar. But sometimes you'll want more specific control over the voicing used on a specific pad (for example, by setting the notes used with your MIDI keyboard), and in that case you can deactivate the AV system for that pad altogether and, as an extra 'failsafe', use the Lock button to ensure your chosen voicing doesn't get altered.

### Test Your Theory

From a songwriting perspective, the new ability to open the Chord Assistant directly in the Chord Pad system is very useful. This can be toggled on/off using the 'right panel' button, located at the top right of the window. There are three display options available here: Chord Editor, List and Circle of Fifths. They all have their uses, but for creating an initial chord selection from scratch, I think the Circle of Fifths display is particularly useful.

To start with a blank set of pads, use the Select All button on the left of the lower row of toolbar items, and then hit the Delete

■ The updated Chord Pad window incorporates the Chord Assistant, including its handy Circle of Fifths display, in a panel on the right.

button. You can then select the root note of the key you wish to use from the drop-down box at the top left of the toolbar, and choose between major or minor keys in the Chord Assistant. The Circle of Fifths display will automatically adjust to place your root-note chord at the centre of its display.

The beauty of this display is twofold. First, even if your music theory knowledge is a work in progress, the arrangement of the chords gives you a clear indication of which chords are most likely to work well together in your chosen key. The seven basic triad chords in the selected key are shown in the upper quadrant of the display, and are also indicated with Roman numerals that show the position of their respective root notes in the scale (three major, three minor and the

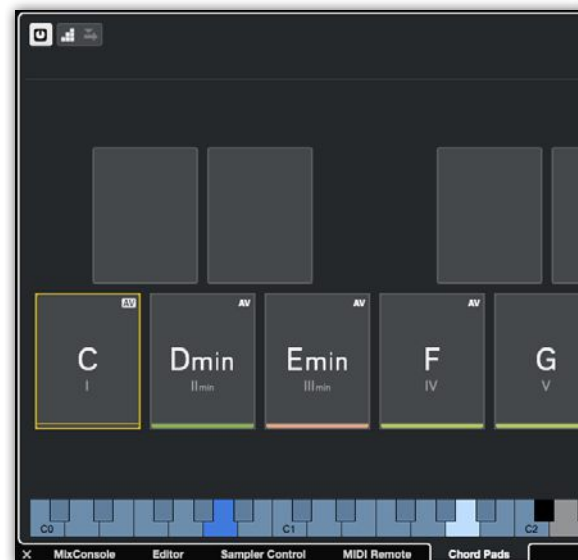

'harmonically challenging' diminished VII chord). As you move further away from this upper quadrant, all the chords shown stray progressively further 'out of key'. As a result, they might be more difficult to place in a chord sequence with your 'in key' chords — but, equally, the occasional unexpected chord choice can often be really helpful in giving a sequence a unique, engaging feel. The ease with which this sort of experimentation can be explored is one of the real advantages of the Chord Pad system.

Second, you can now assign a chord to a Chord Pad simply by dragging from the Circle of Fifths display to an empty Chord Pad. And with the Circle of Fifths display to guide your choices, you can simply repeat this process until you've built a set of chords to explore.

### Colourful Chord Changes

As shown in the second screenshot, I've done this for all the basic chords in the C major scale, starting at Chord Pad C0. For simplicity in triggering, I've confined the triggers to the white notes. But having expanded the number of Chord Pads (as mentioned earlier) to span two octaves, I've then added a second instance of each chord, with adjustments that give me access to something beyond the basic triads. If I want to add some more harmonically interesting chords in my sequence, it's now just as easy as triggering the basic triads.

The two sideways arrow buttons in the toolbar (Less Tensions and More Tensions)

■ You can now create larger sets of Chord Pads and the Chord Assistant's List display makes it easy to add more harmonically complex chords to your selection.

can be used to create these extended chords. But if you switch from the Circle of Fifths display to the Chord Editor display in the Chord Assistant panel, then you get even more control over these extended chord options. Usefully, the chords automatically audition themselves as you make selections.

From a 'songwriting assistant' perspective, there are a couple of other really useful additions to the pads display. First, in the Chord Pad Display Settings dialogue, you can add either Roman Numerals or Nashville Number System labels to the pads, either as the primary or secondary label. Chord sequences are often abbreviated to these number sequences (for example, the classic I, V, iv, IV that's been used in a gazillion hit songs) because it provides a concise summary of the chord sequence that would work, whatever the key. It can be super-useful to see these labels on the pads themselves as you explore your own chord sequence ideas.

The other addition, which I reckon is a really clever one, is the interactive colour coding of the Chord Pads. When you trigger a pad, Cubase applies a little bit of music theory in the background and instantly colour codes (at the bottom strip of the pad) the more obvious 'next chord' destinations for you. A shade of green indicates the most obvious destinations, while yellow, orange or red suggest chords that will create a progressively more dramatic change. This process happens in real time as you play, so as you search for some chord sequence ideas, you'll find that your 'virtual assistant' has always got your back with a suitable idea or two as to where to

go next! Whatever your level of music or harmony knowledge, and whether you wish to use it to follow the suggested wisdom or deliberately choose not to, I think this is genuinely useful.

### Did I Play That?

From this point on, it's all about having fun and letting the creative process happen, and with these enhancements to the Chord Pad feature set it's even easier to experiment with chord sequences than ever. You needn't worry about your keyboard chops or struggle to draw on a partial knowledge of music theory — it can be a really liberating experience. And when you are happy with your chord sequence, hit the record button, trigger your one-finger chords, and the full triggered chords, however complex, will be present and correct in the resulting MIDI clip.

Once you've created a useful Chord Pad configuration, don't forget to save it as a preset. And if you decide the key needs adjustment when you try to sing a topline over your chords, you can simply change the root note from the drop-down mentioned earlier — the Chord Pads will just transpose to suit (note that you can defeat this automatic change if required).

Over multiple releases, the Chord Pad system has gradually evolved into a really powerful feature in Cubase, but the 'songwriting assistant' workflow that I've described above is just one way it can be used — so I'll return to explore other applications for the Chord Pads in a future workshop or two. Until then, let your one-fingered chord sequence writing run free and generate some new song ideas. ■■■

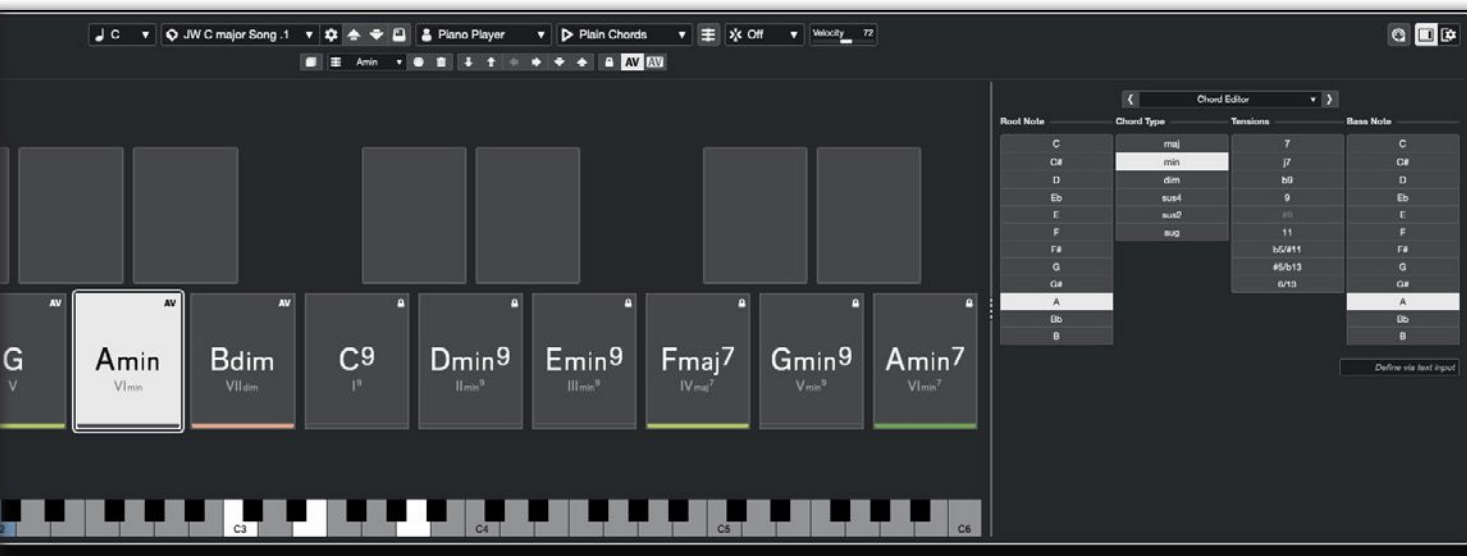



## We hand over the studio keys to Logic's new AI-powered Mastering Assistant.



### PAUL WHITE

The recent 10.8 update to Logic (for macOS 13.5 or above) included quite a few new features, but the one that seems to be attracting the most interest is the automatic Mastering Assistant. This is based on machine learning, or 'AI' as it tends to get called these days. While different styles of music require different approaches when it comes to mastering, practical tests with Logic's Mastering Assistant across a range of styles have been encouraging, and there are some user-adjustable parameters if you're not in full agreement with the end result. Clearly, Mastering Assistant is no substitute for an experienced mastering engineer in a well-equipped mastering suite, but when it comes to knocking your mixes into decent shape for transfer to streaming sites, it's actually very effective.

### Finishing Touch

Mastering Assistant has its own window, which is similar to that of a conventional plug-in. Unlike other plug-ins, however, it is only available in the output mix bus, not

in tracks or busses. On Intel Macs you're limited to a single operational mode called Clean, which does a pretty good job on most material. However, if you have an Apple Silicon machine, you get a choice of different mastering approaches courtesy of the Character menu, which offers a selection of Clean, Valve, Punch and Transparent modes. Clean is a good general-purpose mode, which suits anything that needs to be clear yet punchy. According to Apple it works well on anything from EDM to acoustic music, and my tests seem to corroborate that.

Valve simulates valve circuitry, adding depth to the low end and lifting out the highs, with applications in both acoustic music and styles such as hip-hop. Punch is a little more aggressive, placing more emphasis on the midrange, and is recommended for rock music and similar genres. Transparent is, we're told, inspired by modern, tight-sounding masters and can again be applied to pretty much any musical style. Realistically, the best option is just to try the different modes to see what sounds best for the song regardless of the musical genre. The results from these four options may not sound very

different on first listening, but if you do comparisons of mixes done using the different modes you'll find that they do sound different, and the chances are that one will suit your music better than the others.

### In Use

To use Mastering Assistant, the current project should be set up as though ready for a final mix. Then, when you click on Mastering (in your output strip just below the Audio FX box) to open it, analysis of the track or selected region commences; this takes a minute or so to complete depending on your computer. Once the analysis is finished, you'll see a message saying Assembling Processing Chain, and a progress bar moves along below the bars and beats window at the top of Logic's screen. While we know that the Mastering process involves EQ and dynamics, there's no real clue as to exactly what is in the processing chain, or whether or not that changes depending on the result of the analysis.

The Mastering Assistant GUI shows the resulting EQ curve to the left of the screen, with a dynamic spectral display





**SOUND ON SOUND**

**VIDEO**

VIDEO DOCUMENTARY ORIGINALS

IN ASSOCIATION WITH



**UNIVERSAL AUDIO**

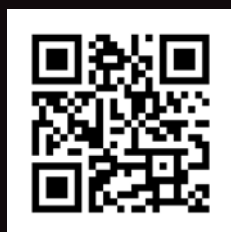

# FRASER T SMITH PRODUCING 'SET FIRE TO THE RAIN'

'Set Fire To The Rain' was Adele's third consecutive US number one, confirming her status as a superstar. In our exclusive video feature, Fraser T Smith tells us how he and Adele wrote the ultimate power ballad, breaks down his production and explains why a humble Yamaha upright piano was the best investment he ever made.

[www.youtube.com/soundonsoundvideo](http://www.youtube.com/soundonsoundvideo)



» below it. If the Custom EQ box at the bottom left of the user interface is active, you'll see three EQ 'blobs' on the centre line that control high (8kHz to 20kHz) and low (20Hz to 200Hz) shelving EQs, flanking a variable-frequency midrange cut or boost control (200Hz to 8kHz). All three sections have a  $\pm 6\text{dB}$  gain range. These points can be moved by dragging them, with their pertinent parameter values shown at the bottom of the window. I found that with all my test material, the applied EQ as calculated by Mastering Assistant didn't usually exceed more than around  $\pm 4\text{dB}$ .

An Auto EQ slider adjusts the amount of the applied EQ as computed by Mastering Assistant, and the slider defaults to its midway position denoting 100 percent. The slider allows the amount of EQ to be adjusted from none at all right up to 200, so if you think the process has gone too far, you can 'dilute' its EQ contribution. Alternatively, if you like what it does so much that you want more, you can push it up beyond 100 percent, but be careful!

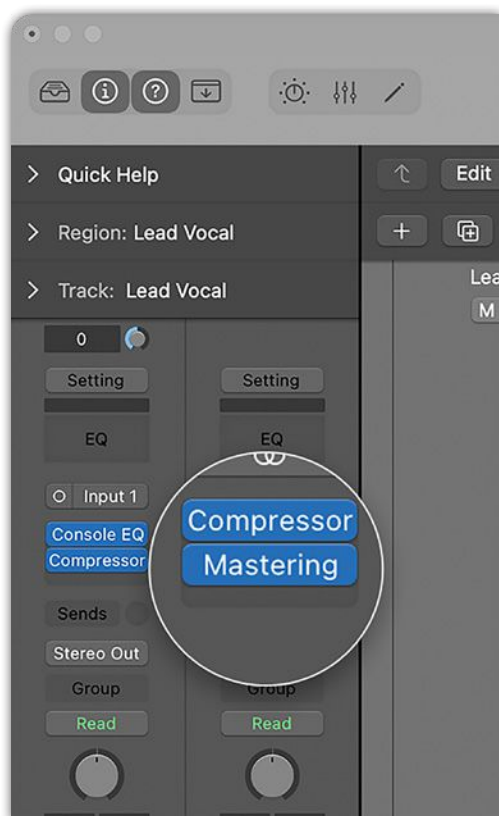

■ The Mastering Assistant plug-in can only be inserted on the main output bus.

If you later make any changes to your mix balance, you can click on the Reanalyze button to calculate a new curve.

### Louder, Brighter, Wider

When a cycle range is set, the Analyze button changes its name to Reanalyze Section. Bypass lets you hear what Mastering Assistant is doing, and to avoid the 'loudest sounds best' trap, there's a Loudness Compensation button at the bottom right of the window that lets you hear the processed and bypassed

**“Mastering Assistant is no substitute for an experienced mastering engineer in a well-equipped mastering suite, but when it comes to knocking your mixes into decent shape for transfer to streaming sites, it's actually very effective.”**

signals at the same perceived level. Once you're happy with the results you can bounce your project, but before you do that, there are a couple of other tweaks you can make if need be.

The Loudness knob adjusts the loudness of the processed audio, and there's a loudness meter that measures the loudness level as your track plays. In its centre position, the Loudness knob delivers an output typically registering at around  $-14\text{LUFS}$ , a good figure for most streaming platforms including Apple Music. This figure can be moved up or down according to the engineers's needs and tastes by adjusting the Loudness control.

Want more energy further up the spectrum? The Excite button brings in a little upper-midrange saturation, pushing the mix forward. Apple tell us that this is based on the sound of vintage transformer-based console designs. The amount isn't variable, but doesn't sound excessive on most material.

Metering shows True Peak levels (double click to clear the read-out) and LUFS. The LUFS meter has M, S and I fields that indicate the current momentary, short-term, and integrated loudness measurements of your

processed mix. The loudness for each measurement (M, S, I) is represented by a green bar when the levels are safe, but this turns yellow if the measured loudness exceeds the target loudness. The Integrated LUFS meter can also be paused, holding at the last measured value. A Reset button clears current readings on the integrated loudness meter.

Mastering Assistant also includes a correlation meter: if you find that the reading is constantly below the zero position, this may indicate out-of-phase components that would be problematic when listening in mono. In that case, you can decrease the stereo width of your mix using the Width control. Mastering Assistant sets this to what it calculates is the best position after analysing your mix, but the user can still adjust it to either narrow

or widen the stereo image. Once you're happy with the result, you can bounce your track, and the changes Mastering Assistant has made will be baked in.

### Great Expectations?

With most mixes, and with no intervention, you can expect that Mastering Assistant will essentially do some fine-tuning EQ, as it tries to get your mix to conform to its spectral balance criteria — however it figures them out. Dynamic processing is also applied, as well as level adjustment to meet a nominal  $-14\text{LUFS}$  integrated loudness. The additional three-band EQ allows for broad-strokes user intervention if the AI-adjusted mix doesn't feel quite right tonally, and there's scope to increase or decrease the overall loudness and stereo width too. Other than that, you can try the Exciter button to see if that does anything useful, and if it does but you feel it has gone a bit too far, you can always use the manual EQ to dial back some of the upper mids to see if that gets you closer to where you want to be.

I'll end then as I started, by saying that while Mastering Assistant isn't going to put professional mastering engineers out of work any time soon, it does help to create mixes that sound more solid, cleaner and more transparent, and which are at the right loudness level for submitting to streaming sites. Whatever is going on under the hood, it's pretty impressive! **///**

# SOUND BLOCKS

## MODULAR ACOUSTICS REDEFINED

Effective absorption down to 50Hz

Free-standing or wall-mounted

Optional face plates for  
added diffusion

250mm deep

The market leader in bass control

### ANY QUESTIONS?

Get **FREE** acoustic advice  
for your space!

Visit us at [www.gikacoustics.co.uk](http://www.gikacoustics.co.uk) and use  
our acoustic advice form or 3D-Visualiser

 **GIK ACOUSTICS**  
SOLUTIONS. INNOVATIONS. QUALITY. EUROPE

 **GIK ACOUSTICS**  
SOLUTIONS. INNOVATIONS. QUALITY. EUROPE



## The Advertisers Index

AMS Neve	© 01282 457011	95	London South Bank University	<a href="http://www.lsbu.ac.uk">www.lsbu.ac.uk</a>	17
Antelope Audio	<a href="http://www.antelopeaudio.com">www.antelopeaudio.com</a>	75	Modartt	© 0033 534 320 330	21
API Audio	<a href="http://www.apiaudio.com">www.apiaudio.com</a>	45	MOTU	<a href="http://www.motu.com">www.motu.com</a>	OBC
Aston Microphones	<a href="http://www.astonmics.com">www.astonmics.com</a>	3	Orchestral Tools	<a href="http://www.orchestraltools.com">www.orchestraltools.com</a>	79
Audient	© 01256 381944	19	PSPaudioware	<a href="http://www.pspaudioware.com">www.pspaudioware.com</a>	37
Black Lion Audio (RAD Distribution)	<a href="http://www.blacklionaudio.com">www.blacklionaudio.com</a>	43	Scan Computers International	© 01204 474747	39
CMA Audio	<a href="http://www.lake-people.de">www.lake-people.de</a>	41	SCV Distribution	© 03301 222500	9
DV247	© 01708 771900	25	Softube	<a href="http://www.softube.com">www.softube.com</a>	31
Fabfilter Software Instruments	<a href="http://www.fabfilter.com">www.fabfilter.com</a>	73	Sontronics	<a href="http://www.sontronics.com">www.sontronics.com</a>	29, 67
Focusrite Audio Engineering	<a href="http://www.focusrite.com">www.focusrite.com</a>	85	Sound Radix	<a href="http://www.soundradix.com">www.soundradix.com</a>	11
Genelec	<a href="http://www.genelec.com">www.genelec.com</a>	63	Sound Service MSL Distribution	<a href="http://www.sound-service.eu">www.sound-service.eu</a>	15
GIK Acoustics Europe	<a href="http://www.gikacoustics.com">www.gikacoustics.com</a>	49, 145	Sound Technology	© 01462 480000	5
Groove Synthesis	<a href="http://www.groovesynthesis.com">www.groovesynthesis.com</a>	103	Soundtoys	<a href="http://www.soundtoys.com">www.soundtoys.com</a>	119
Headline Audio	<a href="http://www.headlineaudio.com">www.headlineaudio.com</a>	59	Synthax Audio UK	<a href="http://www.synthax.co.uk">www.synthax.co.uk</a>	23
Heritage Audio	<a href="http://www.heritageaudio.com">www.heritageaudio.com</a>	115	TEAC UK	© 01923 797205	33
Kenton Electronics	© 020 8544 9200	69	Toontrack	<a href="http://www.toontrack.com">www.toontrack.com</a>	IBC
KMR Audio	© 020 8445 2446	13	Warm Audio	<a href="http://www.warmaudio.com">www.warmaudio.com</a>	IFC





# **SOS** WHY I LOVE... OLD KEYBOARD MIXERS

ALEX BALL

Back in the pre-computer days, having lots of sounds at hand, or being able to record a demo to a tape machine at home, meant having lots of hardware like organs, synths, sequencers and drum machines. Manufacturers saw the need for straightforward and affordable mixers to handle the stack of electronics and bring it all down to a simple stereo pair, or even just a mono output.

These keyboard mixers could have other uses, but the intended market was made quite clear by the initials, with the Boss KM series or the Korg KMX range being examples.

Lots of manufacturers made these kinds of products, and having spoken to some friends who used them at the time, they were a bit frustrating at times because they had

quite extreme EQs and could very easily overdrive and saturate... which is precisely why they're interesting now.

To make things even more exciting, another popular use for these products was karaoke and, whilst I can't imagine the horrors that befell these mixers in those situations, they were often endowed with spring reverbs and even bucket-brigade delays to help the (probably unhelpable) situation. Some of these mixers even had weird little rhythm machines built into them too! (Check out the Yamaha EM-90 if you don't believe me.)

There were so many of these kinds of products made that they're relatively easy to find. Some have some fame, and an associated price tag, but many don't.

With so many great digital products available now, including all those in your

computer, sometimes things can get a bit clean and clear, and that's where these things can be a handy solution. I run all sorts of stuff through a pair of old Maxon/Ibanez mixers, and the drive and saturation can really add a lot of life to a sound. There's also effects sends to play with, and so I stick rack units and pedals on those and record the whole outcome back into my DAW.

It's also worth setting up a bunch of equipment on different channels and recording it all at once into your DAW. Yes, this is kind of silly, because now you can't isolate anything or mix it later, but if you get it all gelling and vibing on an old keyboard mixer, perhaps that's the mix? Why not dare to commit? A halfway house would be to record groups of things through these mixers as broad stems to allow for a bit more flex later.

When I recorded my most recent album, half the songs were multitracked in the usual way, but half were done through the Ibanez mixer in one pass with no additional mixing done, or even possible. Listening back, the live mixes sound better to me than the ones I spent time mixing.

It seems extremely obvious to point out, but there's something to be said for getting the whole track working on a fundamental level before pressing record. This can easily be forgotten when we are used to building things up in a Lego fashion within the computer (which I love too, by the way).

So, if you're looking a slightly different way to work, maybe grab a grubby old keyboard mixer and see what you think. **///**

## NEXT MONTH IN **SOUND ON SOUND**

Are the new Icon control surfaces the missing link between human and DAW? Find out in our in-depth review.

March issue on sale Thursday 22nd February.  
Available at WH Smith and all good newsagents.  
Subscribe at [www.soundonsound.com/subscribe](http://www.soundonsound.com/subscribe).





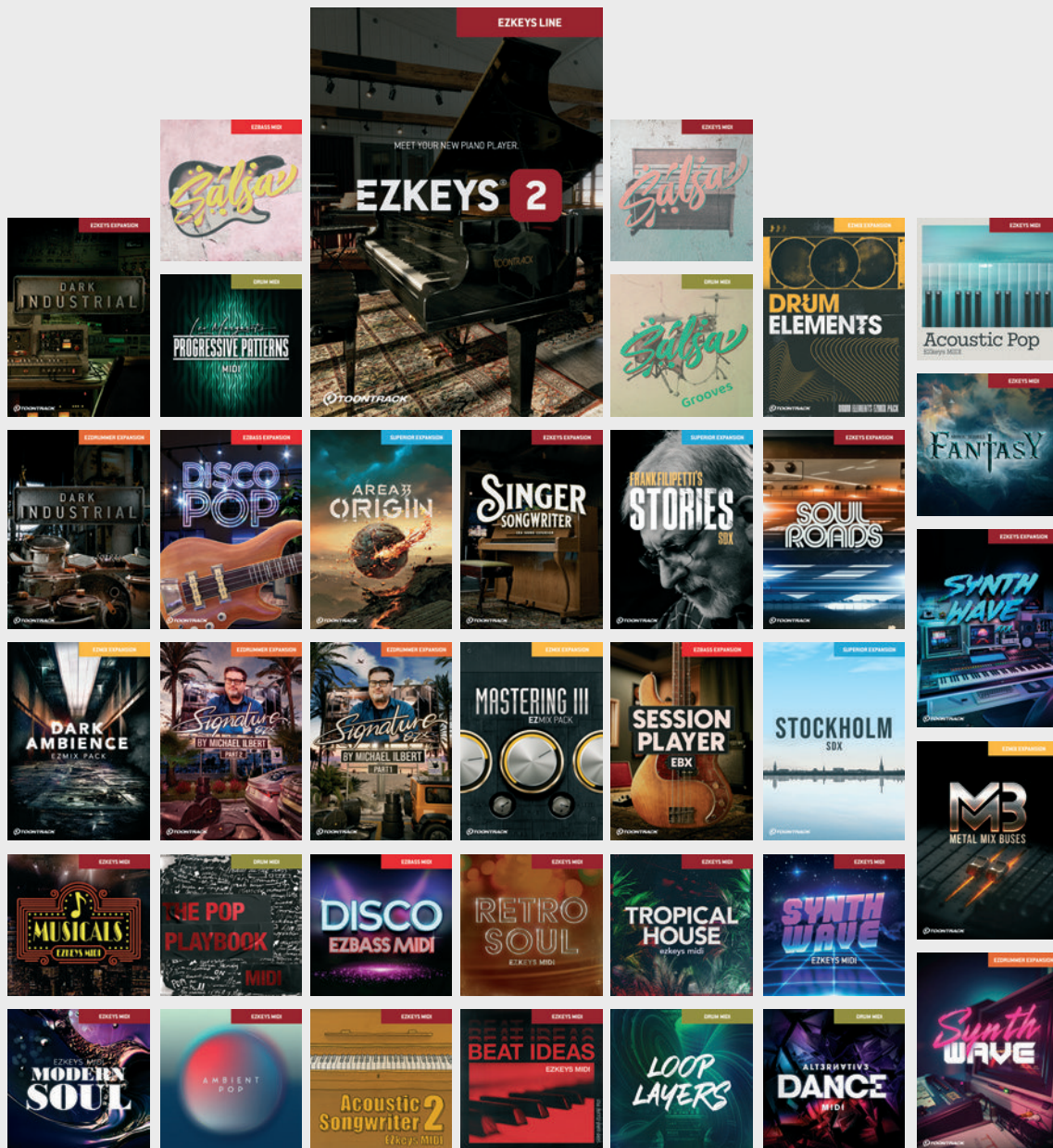

As we close the books on 2023, we proudly look back on 36 new titles spanning a wealth of styles. Out of all these new releases, one that stands out a little extra is of course **EZkeys 2**. As for 2024, we promise to keep up the same pace. See you on the site!

*Toontrack*





# MOTU®

## M SERIES

[MOTU.COM/M-SERIES](https://www.motu.com/m-series)

FREE eBook

# RECORDING TECHNOLOGY BASICS & BEYOND

Get your FREE digital publication from Sound On Sound

This FREE illustration-rich eBook is aimed primarily at newcomers to the subject, but will prove equally valuable to anyone struggling with the complexities of today's sophisticated recording technology.

The purpose of this 170-page guide is to introduce readers to the essential components of a modern recording system and to explain the recording process in an easy-to-follow way, demystifying the inevitable jargon, both as it crops up, and with a comprehensive glossary.

Written in the accessible, no-nonsense style of the Sound On Sound team of authors and editors, **Recording Technology: Basics & Beyond** covers:

- What to buy
- Studio setup
- Computers for audio
- Audio interfaces
- Monitoring
- Acoustic treatment
- Mic techniques
- How digital audio works
- Understanding your DAW software
- Upgrading your system
- Software instruments
- Wiring your studio
- Plug-ins
- Recording audio
- Understanding MIDI
- Recording vocals
- Mixing
- Compressors
- Equalisation
- Mastering
- Glossary

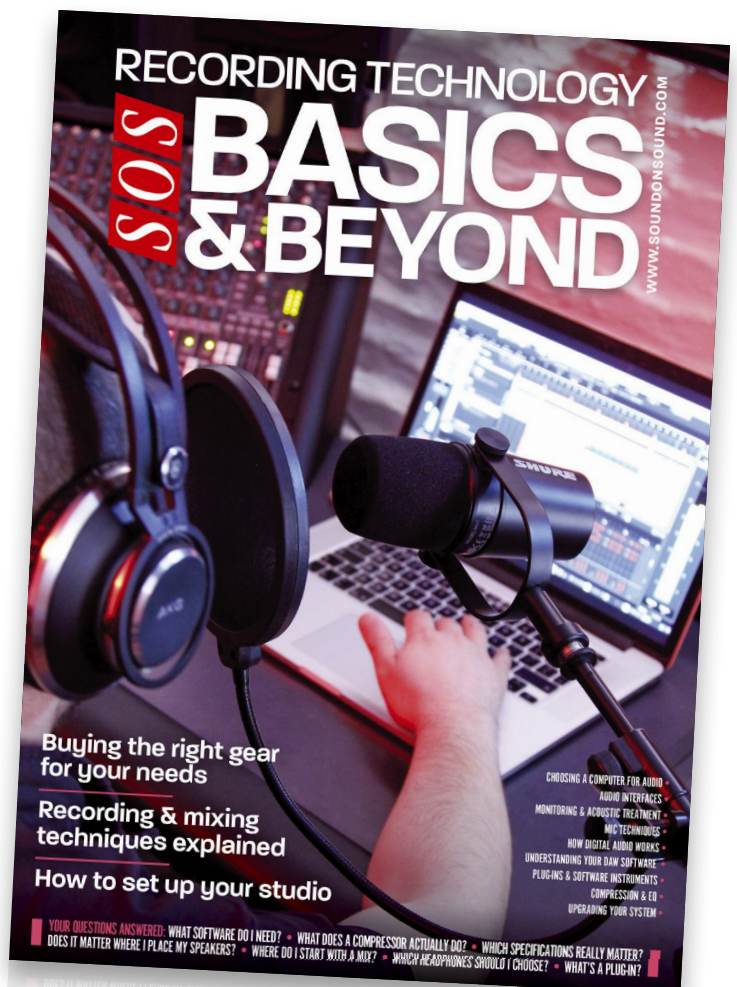

Don't miss out! Sign up and **share the link** with friends and colleagues on social media.

<https://sosm.ag/recording-ebook>





# MIX WITH THE BEST

**"I have been a reader of Sound On Sound for as long as I can remember. The amount of enlightening information, the intelligence of the writing, the beautiful print quality, and the personal stories make it as useful as the audio tools it covers. I'm a huge fan."**

**Jacquire King**  
Engineer, mixer, producer, Grammy Award winner (Kings of Leon, Norah Jones, Tom Waits, James Bay).

**"I love the magazine. There are certain magazines you read where you take everything with a grain of salt and you're not quite sure if you believe it. And Sound On Sound, when I read it, I believe it. It feels as though its only agenda is people reporting on stuff they're interested in."**

**Andrew Scheps**  
Engineer, producer, mixer, Grammy Award winner (Lana Del Rey, Hozier, Jay-Z).

**"Sound On Sound is informative from cover to cover, and I always read it. I always learn something from reading the interviews, and I rely on the new gear reviews. I look forward every month to the next edition."**

**Cenzo Townshend**  
Engineer, producer, mixer, two-time winner of Best Mix Engineer at Music Producers Guild Awards (U2, the Maccabees, Jungle).

# SOUND ON SOUND

These articles were originally published in Sound On Sound magazine, February 2024 edition



## Subscribe and Save Money!

Visit our subscriptions page at [www.soundonsound.com/subscribe](http://www.soundonsound.com/subscribe) for more information on the Sound On Sound App go to: [www.soundonsound.com/app](http://www.soundonsound.com/app)



All contents copyright © SOS Publications Group and/or its licensors, 1985-2024. All rights reserved.

The contents of this article are subject to worldwide copyright protection and reproduction in whole or part, whether mechanical or electronic, is expressly forbidden without the prior written consent of the Publishers. Great care has been taken to ensure accuracy in the preparation of this article but neither Sound On Sound Limited nor the publishers can be held responsible for its contents. The views expressed are those of the contributors and not necessarily those of the publishers.