Color 16 Split System

User's Manual

Directory

1. System Features	2
2. Rear Panel Installation	3
3. Front Key Operation	4
4. Function description	5
4.1 Button MENU / AUDIO.....	5
4.2 Button AUTO/ FREEZE.....	5
4.3 Button ZOOM/MODE	5
4.4 Button VCR / ENTER.....	6
4.5 Button M4-A / ▲.....	6
4.6 Button M4-B / ▼.....	7
4.7 Button M8/◀.....	7
4.8 Button M9/▶.....	7
4.9 Button 1/9 / FULL, 2/10 / FULL, 3/11 / FULL...ect.....	7
4.10 PAL/NTSC System.....	7
4.11 PTZ Function.....	7
5. Setup Menu Operation	9
5.1 Setup Main menu.....	10
5.2 System Setup Menu.....	10
5.3 Display Setup Menu.....	12
5.4 Camera Setup Menu.....	13
5.5 Auto Sequence Setup Menu.....	14
5.6 Event Setup Menu.....	15
5.7 Event Report.....	16
5.8 Event List Clear Menu.....	17
6. RS-232C and RS485 Interface	18

1. System Features

- 4 channel audio input, 1 channel audio output
- Connects up to 4/8/16 Video Camera
 - Adjustable Brightness, Contrast, Saturation, Hue and Sharpness
- High Resolution
 - 720X480 60Hz for NTSC
 - 720X576 50Hz for PAL
- Various Display Modes
 - 4 /8/16 Split Mode
 - Full Screen Mode
 - PIP Screen Mode
 - Realtime 8 Split Mode
 - Non-realtime 16 Split Mode
 - Dual Split Mode
 - Auto Sequence Mode
- High Performance Freeze Function
 - Flicker Free Image Capture
- High Performance Zoom Function
 - Selectable Zoom Area
- Various Overlay Information
 - Camera Title
 - Real Time and Date
 - Loss Message
- Playback in DUAL QUAD or Full Screen Image
- Provide Various Event Input and Detection
 - Video Loss Detection
 - 60 Event Report
 - Built-in Buzzer and Relay Output
- Remote Control by Infrared Transmitter and RS-232 connection (option)
- Camera Control by RS485 connection (option)

2.Rear Panel Installation

16 Split system

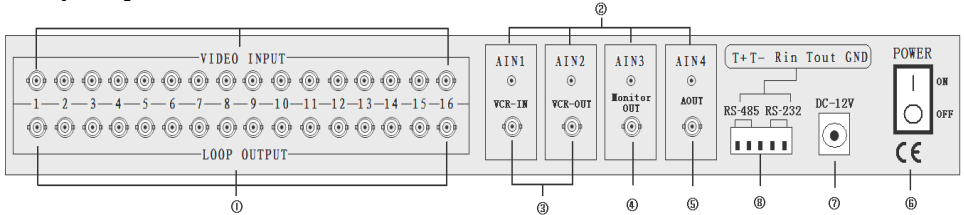

Camera Connection

Accept 16 loop composite video inputs from the camera.

Monitor Connection

Provide 1 composite video output for the main monitor.

VCR OUT Connection

Provide 1 composite video output for recording in the VCR.

VCR IN Connection

Accept 1 composite video input for playback from the VCR.

AUDIO IN Connection

Accept 4 composite audio inputs from the camera.

AUDIO OUT Connection

Provide 1 composite audio output for the main monitor.

RS485 / RS-232 Connection

Provide RS485 interface to control camera.

Provide RS-232 interface to be controlled by HOST.

Power Switch

1 : ON

○ : OFF

Power Jack Connection

DC 12V/1.5A, Center is positive

3.Front Key Operation

16 Split system front panel

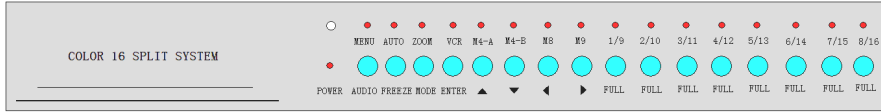

*Note: (*L) – Press key continuously more than one second to enter menu options.*

*(**S) – Press key less than one second to enter menu options.*

- (1) **MENU (*L)** : Enter or Exit main menu mode.
AUDIO (S)** : switch audio channel or turn off audio
- (2) **AUTO (*L)** : Auto channel switch ON/OFF
FREEZE (S)** : Press it to freeze/un-freeze display windows.
- (3) **ZOOM (*L)** : Enter or exit ZOOM display mode.
MODE (S)** : Enter 16 Split ,picture in picture and Dual Split mode.
- (4) **VCR (*L)** : Enter Playback function
ENTER (S)** : Enter menu setup
- (5) **M4-A / ▲ (*L)** : Enter or Exit PTZ control function
M4-A / ▲ (S)** : Master QUAD display / up direction button
- (6) **M4-B / ▼ (**S)** : Slave QUAD display / down direction button/switch channel for PTZ controlling
- (7) **M8/◀ (**S)** : 8 Split display / left direction button
- (8) **M9/▶ (**S)** : 9 Split display / right direction button
- (9) **1/9 / FULL** : Channel 1 (channel 9) display
- (10) **2/10 / FULL** : Channel 2 (channel 10) display
- (11) **3/11 / FULL** : Channel 3 (channel 11) display
- (12) **4/12 / FULL** : Channel 4 (channel 12) display
- (13) **5/13 / FULL** : Channel 5 (channel 13) display
- (14) **6/14 / FULL** : Channel 6 (channel 14) display

(15) 7/15 / FULL : Channel 7 (channel 15) display

(16) 8/16 / FULL : Channel 8 (channel 16) display

4. Function description

4.1 Button MENU / AUDIO

- **MENU**: Press the MENU (*L) button to enter or exit menu setup.
- **AUDIO** : Press the AUDIO (**S) button to switch audio channel to listion in or turn off audio.

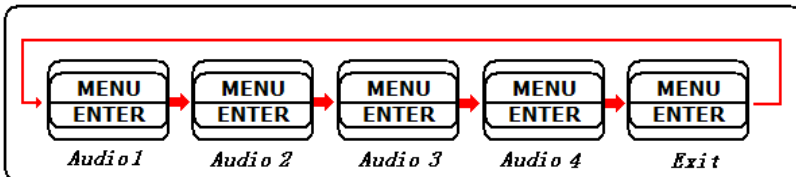

4.2 Button AUTO/ FREEZE

- **Auto** : Press the Auto (*L) button to sequentially display the turned-on video channels (CH1,CH2,CH3,CH4.....CH16, 8 split and 16 split if turned ON in the Auto sequence setup mode) in the display mode windows. The time of display video channels can be programmed by menu setup. Press any key exit AUTO mode.
- **Freeze** : Press the Freeze (**S) button will freeze/un-freeze the display window.

4.3 Button ZOOM/MODE

- **ZOOM** : Press the ZOOM (*L) button to enter 2 * ZOOM mode. The user can use the "M4-A /▲", "M4-B /▼", "M8/◀", "M9/▶" buttons to move the ZOOM-in frame. Press the ZOOM (*L) button again will return to previous display mode.

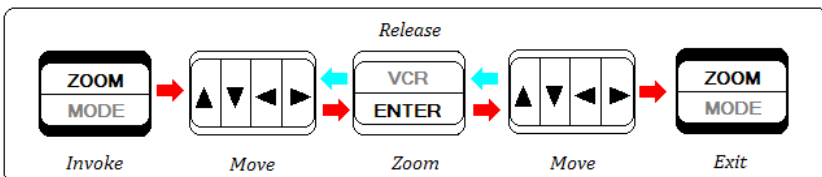

- **MODE** : Press the MODE (**S) to enter the MODE setup mode. By default, the display modes are circulated as the

following sequence, Non-realtime 16 Split, realtime 8split,2 Picture-in-Picture, 1 Picture-in-Picture and Dual Split for each MODE key .

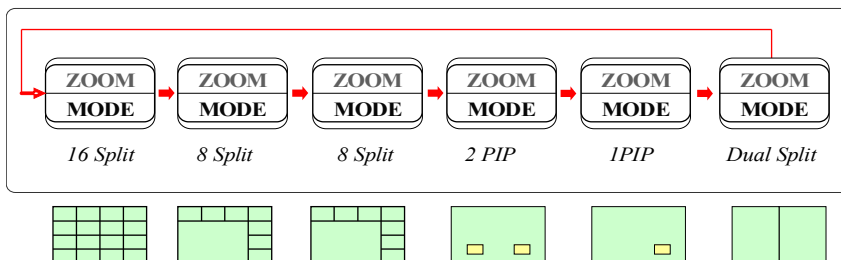

In 8split and PIP mode, press “ENTER” key enter setup function for select display channel and channel display area. Press up and down (▲▼) key to select item to setup . Press left and right(◀▶) key to select which value we needed. Press “ENTER” key again to exit this setup function.

In two screen compared mode, select any two channel to compared screens. Press “ENTER” key enter setup function for select display channel and circle display star area. Press up and down(▲▼) key to select item to setup. Press left and right(◀▶) key to select which value we needed. Press “ENTER” key again to exit this setup function.

4.4 Button VCR / ENTER

- **VCR** : Press the VCR (*L) button to enter VCR playback mode. The user can use 4 arrow keys and 4 channel keys(▲, ▼, ◀, ▶ , 1/9 , 2/10 , 3/11,4/12) to select each channel in the VCR mode. Press the VCR (*L) button again will return to previous display mode.
- **ENTER** : In menu setup mode ,press the ENTER (**S) to select the value.

4.5 Button M4-A / ▲

- **M4-A**: Press the M4-A (*L) button to enter PTZ controlling function.Press the M4-B (*L) button again to exit PTZ controlling function.
- **M4-A**: Press the M4-A (**S) button to display master QUAD.
- **▲**: Press the ▲ (**S) to move cursor in menu setup.

4.6 Button M4-B / ▼

- M4-B: Press the M4-B (**S) button to switch channel for PTZ in opening PTZ function.
- M4-A: Press the M4-A (**S) button to display slaver QUAD.
- ▼: Press the ▼ (**S) to move cursor in menu setup.

4.7 Button M8/◀

- M8: Press the M8 (**S) button to switch 8 split display.
- ◀: Press the ◀ (**S) to move cursor or adjust the value in menu setup.

4.8 Button M9/▶

- M9: Press the M9 (**S) button to switch 9 split display.
- ▶: Press the ▶ (**S) to move cursor or adjust the value in menu setup.

4.9 Button 1/9 / FULL, 2/10 / FULL, 3/11 / FULL...ect.

- 16 channel keys select camera to be displayed as full screen.

4.10 PAL/NTSC System

System can be defined as NTSC or PAL standard with the following method. The first method is power on with pressing 7/15 or 8/16 key and the second one is to define in the setup menu.

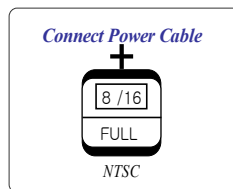
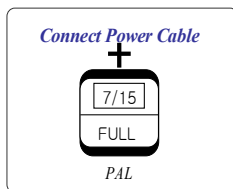

4.11 PTZ Function

- (1) Press the MENU (*L) key to enter the system establishment main menu, choose "system setup" and enter by press the ENTER (**S) key, "ptz setup" must establish for "yes", then press the ENTER (**S) key to enter the sub-menu. Then adjust the value to ensure the value match as the channel of ptz connected.
- (2) Press the M4-A (*L) button to enter PTZ controlling function. Press the M4-B (*L) button again to exit PTZ controlling function.

(3) Press the M4-B (**S) button to switch channel for PTZ controlling when the ptz controlling is effective

(4) The control key definition (as follows):

◀: stop; 8/16 FULL: automatic pattern
▶ : right ; 1/9 FULL : left ;

(direction)

2/10 FULL: down 3/11 FULL: up;
4/12 FULL: near 5/13 FULL: far (focal distance)
6/14 FULL: big 7/15 FULL: small (aperture)

PTZ SETUP			
CHANNEL	ID	BAUD RATE	PROTOCOL
01	01	2400	PELCOD
02	02	2400	PELCOD
03	03	2400	PELCOD
04	04	2400	PELCOD
05	05	2400	PELCOD
06	06	2400	PELCOD
07	07	2400	PELCOD
08	08	2400	PELCOD

▼ ▲ SELECT ◀ ▶ ADJUST MENU EXIT

5. Setup Menu Operation

The system provides a built-in GUI setup screen. For each menu, the key function is described in the lower region to help operation. The following figure shows the structure of GUI menu.

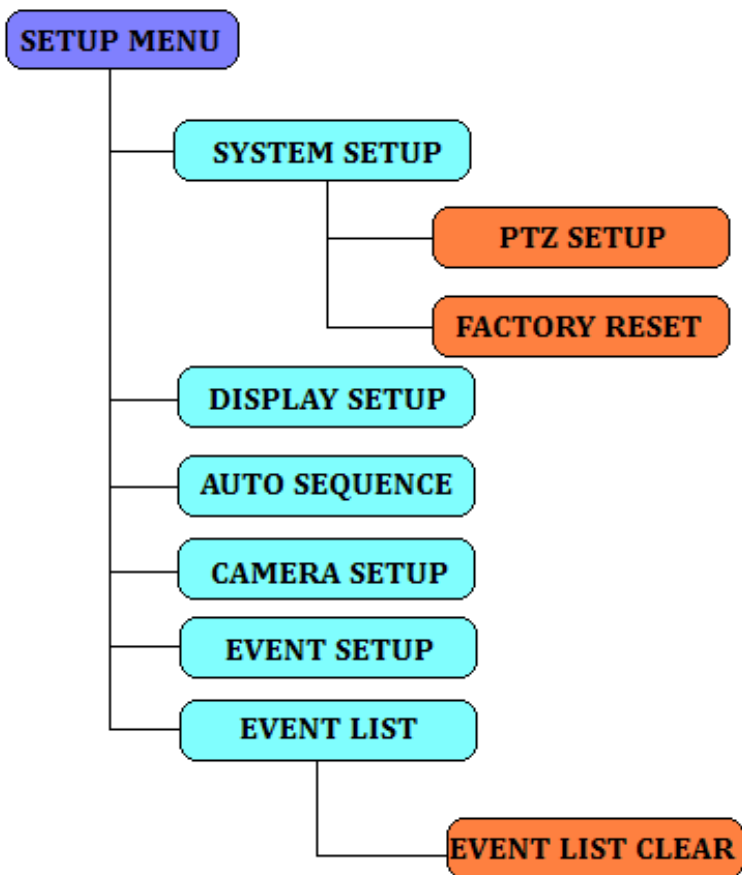

5.1 Setup Main menu:

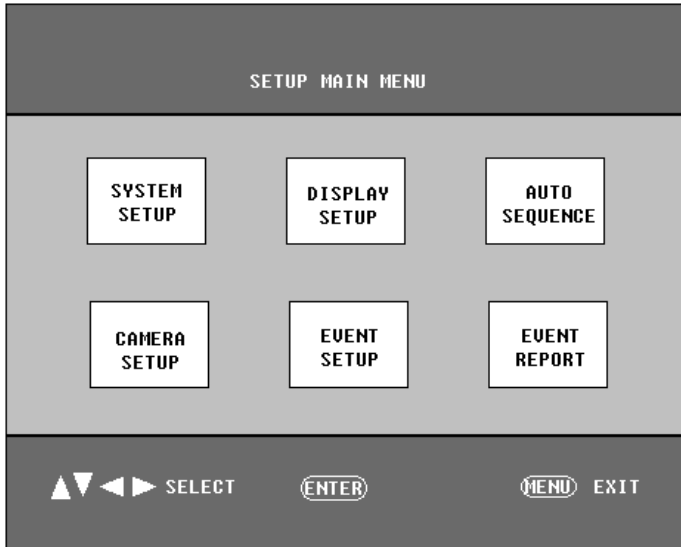

Press **MENU (*L)** key to enter main menu setup.

Move cursor to the item of needed setup with ▲/▼. Press ◀/▶ to select the value. Press ENTER key to enter submenu.

Press **MENU (**S)** key to exit last menu.

Press **MENU (*L)** to exit main menu setup.

5.2 System Setup Menu

- 1) Press ▲/▼ to select the item of setup .Press ◀/▶ to select the value ;
- 2) DATA : there are three kinds of display format to data : MM-DD-YY DD-MM-YY , YY-MM-DD。 Default : YY-MM-DD, 07-07-07
- 3) TIME: time setup. HH : MM : SS is hour, minute and second.
Default : 12 : 00 : 00.
- 4) SYSTEM FORMAT : PAL / NTSC. Default : PAL ;
- 5) PTZ SETUP : If select YES, press ENTER to enter PTZ setup.
- 6) KEY LOCK: key lock. If select NO, after exit menu setup mode, all key be locked except MENU key.
Default : OFF ;

FACTORY RESET: comeback to factory setup. Press ◀/▶ to select YES or NO. If select NO, press ENTER to enter into next dialog box. Press ◀/▶ to select YES and press ENTER to comeback factory setup. Default : NO

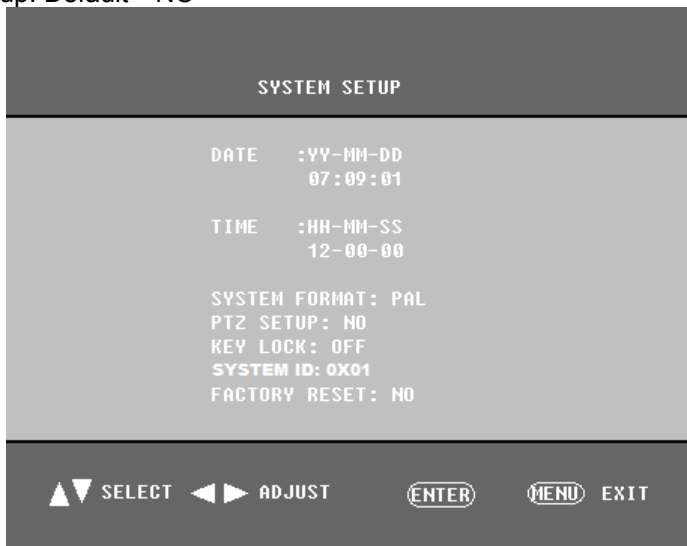

Factory Reset Menu



5.3 Display Setup Menu



- 1 DISPLAY ON SCREEN : Select YES or NO to display camera title, data time in the screen. Press ▲/▼ to move cursor, press ENTER to change state. Display “√”
- 2 SCREEN POSITION : Select screen display area. X position: -10 ~ +10. Y position: -4 ~ +3. Default(X : 0 , Y : 0).
- 3 BORDER COLOR : Border colors have black, gray, white and selected.
Default: GRAY2.

5.4 Camera Setup Menu

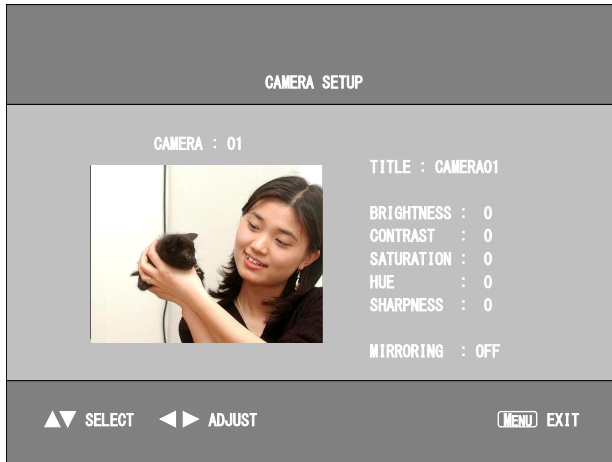

Setup each camera's title / brightness / contrast / saturation / hue / sharpness and mirroring independently.

- 1 CAMERA : Select the camera with ◀/▶.Default: ch1.
- 2 TITLE: Channel name setup. Press ▲/▼ to move cursor to next character and press ◀/▶ to change character. Default: CAMERA1
- 3 BRIGHTNESS : Brightness setup. From -100 to +100 can be selected. Press long ◀/▶ key, value can be continued changed. Default: 0
- 4 CONTRAST : Contrast setup. From -100 to +100 can be changed. Press long ◀/▶ key, value can be continued changed. Default: 0
- 5 SATURATION : Saturation setup. From -100 to +100 can be selected. Press long ◀/▶ key, value can be continued changed. Default :0
- 6 HUE : Hue setup. From -100 to +100 can be selected. Press long ◀/▶ key, value can be continued changed. Default :0
- 7 SHARPNESS : Sharpness setup. From 0 to 3 can be selected. Press long ◀/▶ key, value can be continued changed. Default :0
- 8 MIRRORING : Mirroring display camera screen.

Default: OFF

5.5 Auto Sequence Setup Menu

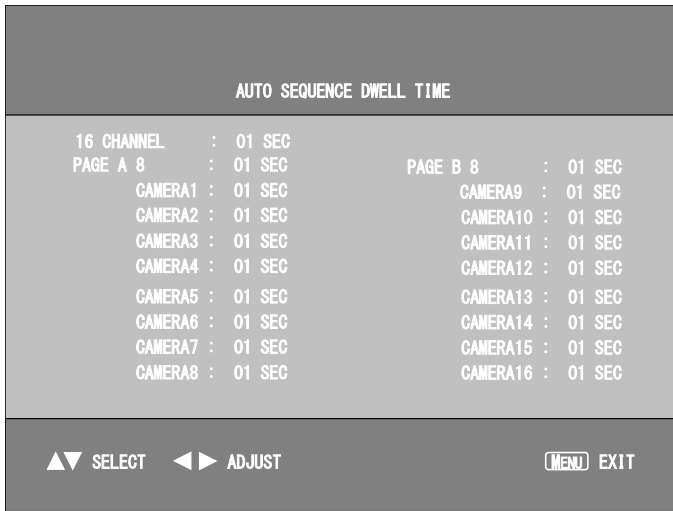

Setup display times of AUTO sequence to each screen. There are skip/1sec~99sec be selected.

Default: 1sec.

5.6 Event Setup Menu

The screenshot shows a terminal-style interface for 'EVENT SETUP'. The main title is 'EVENT SETUP'. Below it is a sub-menu 'BUZZER/REPORT CONTROL'. A row of 16 channels is listed, each with a checkbox under the 'LOSS' column. All checkboxes are checked. Below the channels, the settings are: 'BUZZER HOLD TIME: 05 SEC' and 'REPORT HOLD TIME: 30 SEC'. At the bottom, there are four navigation buttons: 'SELECT' (with up, down, left, right arrows), 'ENTER ENABLE', 'MENU EXIT', and a 'MENU' button.

```
EVENT SETUP

BUZZER/REPORT CONTROL

CHANNEL 1 2 3 4 5 6 7 8 9 10 11 12 13 14 15 16
LOSS                     

BUZZER HOLD TIME: 05 SEC
REPORT HOLD TIME: 30 SEC

▲ ▼ ◀ ▶ SELECT  ENTER ENABLE  MENU EXIT
```

Setup loss detection independently of channels.

- 1 BUZZER/REKPORT : Control buzzer and relay in alarm, video loss and motion states. Press ▲/▼/◀/▶ to select item o and press ENTER to change state. “√” is ON. Default: VIDEO LOSS: NO (√).
- 2 BUZZER HOLD TIME : OFF/1ses~99ses can be selected. Default: 5ses.
- 3 REPORT HOLD TIME : Report of relay.
- 4 Holding time. OFF/1ses~99ses can be selected. Default: 30sec.

5.7 Event Report

EVENT REPORT				
1 OF 6 PAGE				
NO	YY-MM-DD	HH:MM:SS	CH	EVENT
1	07-07-30	16:56:03	1	LOSS
2	07-07-30	16:56:03	2	LOSS
3	07-07-30	16:56:03	3	LOSS
4	07-07-30	16:56:03	4	LOSS
5	07-07-30	17:56:03	1	LOSS
6	07-07-30	17:56:03	2	LOSS
7	07-07-30	17:56:03	3	LOSS
8	07-07-30	17:56:03	4	LOSS
9	07-07-30	18:56:03	1	LOSS
10	07-07-30	18:56:03	2	LOSS

LIST CLEAR : NO

▲▼ SELECT ◀▶ SELECT PAGE [MENU] EXIT

Display every report of alarm. Event report has 6 page totally and 10 recordings per page. Press ◀▶ to change pages.

LOSS: video loss.

ALARM: exterior alarm

MOTION: motion detection.

LIST CLEAR: Clear the list of reports.

5.8 Event List Clear Menu

LIST CLEAR

WARNING!
THIS SYSTEM GETS TO LOSE
THE CURRENT EVENT LIST
AND WILL BE INITIALIZED
WITH BLINK.

ARE YOU SURE?

YES NO

◀▶ SELECT

ENTER

MENU EXIT

6. RS-232C and RS485 Interface

Connection as follow:

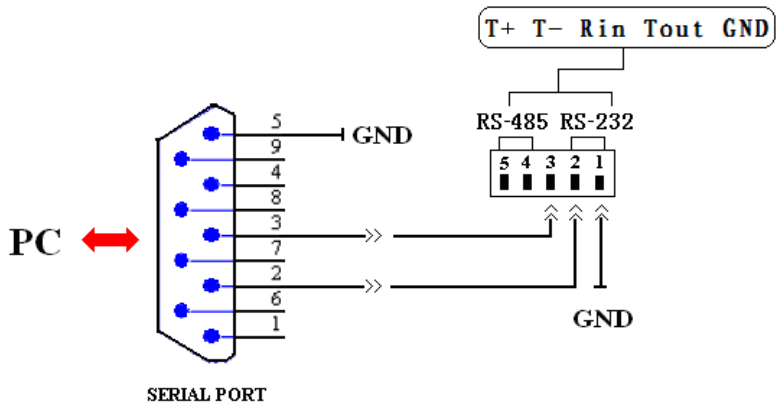

The Explanation of connection as follow:

- 1 Ground must be connected into together : The 5th foot of the serial port connect to the 1th foot of the RS485/RS232 connection .
- 2 The 3th foot of the serial port connect to the 3th foot of the RS485/RS232 connection .
- 3 The 2th foot of the serial port connect to the 2th foot of the RS485/RS232 connection .

RS-232 function Introduction

The RS232 is used for remote control of the machine, baud rate is 9600bps .Meanwhile, the system ID works to provide the range of values which can be modified: 0x01~0XFF. Through the system ID we can operate the machine. How-to, first sent the ID, and then the following stated commands are sent. e.g. Freeze the image on the machine with ID number 0x03, send command :0x03 0xa1.

Receive code

Code (Hex)	Description	Code (Hex)	Description
0x80	NULL	0x95	A Page 8 Unite
0x81	Channel 1	0x96	B Page 8 Unite
0x82	Channel 2	0x97	A Page 9 Unite
0x83	Channel 3	0x98	B Page 9 Unite
0x84	Channel 4	0x99	Non-realtime 16 Split
0x85	Channel 5	0x9a	8 A Page
0x86	Channel 6	0x9b	8 B Page
0x87	Channel 7	0x9c	2 Picture-in-Picture
0x88	Channel 8	0x9d	1 Picture-in-Picture
0x89	Channel 9	0x9e	Dual Split
0x8a	Channel 10	0x9f	Auto Sequence
0x8b	Channel 11	0xa0	Playback
0x8c	Channel 12	0xa1	Freeze
0x8d	Channel 13	0xa2	Zoom
0x8e	Channel 14	0xa3	Menu
0x8f	Channel 15	0xa4	▲
0x90	Channel 16	0xa5	▼
0x91	Quad A Page(1-4)	0xa6	◀
0x92	Quad A Page(5-8)	0xa7	▶
0x93	Quad B Page(9-12)	0xa8	Enter
0x94	Quad B Page(13-16)	0xaa	9 A Page
0xa9	Audio	0xab	9 B Page

CAM1/▲

