

BRIEF COMMUNICATION OPEN

No-cloning of quantum steering

Ching-Yi Chiu¹, Neill Lambert², Teh-Lu Liao¹, Franco Nori^{2,3} and Che-Ming Li¹

Einstein–Podolsky–Rosen (EPR) steering allows two parties to verify their entanglement, even if one party’s measurements are untrusted. This concept has not only provided new insights into the nature of non-local spatial correlations in quantum mechanics, but also serves as a resource for one-sided device-independent quantum information tasks. Here, we investigate how EPR steering behaves when one-half of a maximally entangled pair of qudits (multidimensional quantum systems) is cloned by a universal cloning machine. We find that EPR steering, as verified by a criterion based on the mutual information between qudits, can only be found in one of the copy subsystems but not both. We prove that this is also true for the single-system analogue of EPR steering. We find that this restriction, which we term ‘no-cloning of quantum steering’, elucidates the physical reason why steering can be used to secure sources and channels against cloning-based attacks when implementing quantum communication and quantum computation protocols.

npj Quantum Information (2016) 2, 16020; doi:10.1038/npjqi.2016.20; published online 28 June 2016

INTRODUCTION

Einstein–Podolsky–Rosen (EPR) steering reveals that one party, Alice, can affect, or steer another remote party (Bob’s) state, by her measurements on one particle of an entangled pair shared between them.¹ This concept was originally introduced by Schrödinger in response to the EPR paradox.² Recently, it has been reformulated by Wiseman *et al.*³ as an information-theoretic task to demonstrate that Alice and Bob can validate shared entanglement even if the measurement devices of Alice are untrusted. This has led to a range of conceptually important extensions of the concept of EPR steering and several potential applications for practical quantum information processing. See an in-depth discussion given in the review by Reid *et al.*⁴

As articulated by Wootters and Zurek⁵ and Dieks⁶ in 1982, it is impossible to perfectly copy an unknown quantum state. This famous no-go theorem of quantum mechanics has significant implications in understanding nonclassical features of quantum systems and profound applications in quantum information science. Although one cannot make perfect copies of an unknown quantum state, it is possible to create imperfect copies. Bužek and Hillery⁷ have shown that a universal cloning machine can produce a clone of an unknown state with high fidelity. Such a universal cloning machine has been shown to be optimal and has been extensively studied in the context of possible alternatives, extensions and use as an eavesdropping attack on the protocols of quantum cryptography.⁸

Here, inspired by the no-cloning theorem and the concept of quantum steering, we ask a simple question: ‘Does quantum mechanics allow quantum steering to be copied by a universal cloning machine?’. To investigate this question, we use the concept of a universal cloning machine to consider how quantum steering is cloned and shared between two copies of a qudit (a multidimensional quantum system), which itself is half of a maximally entangled pair (Figure 1a). In addition, we apply the same method of analysis to the single-system (SS) analogue of EPR

steering (SS steering) scenario⁹ (Figure 1b). We find that EPR steering (and SS steering), as described by a criterion based on the mutual information between two parties, can only be observed in one of the two copy subsystems, but not both. We denote this as the ‘no-cloning of steering’. Several applications to quantum information directly follow, such as (i) the observation of steering validates channels against cloning-based coherent attacks when implementing quantum key distribution and (ii) steerability guarantees the reliability of quantum logic gates of arbitrary size for both the quantum circuit model and one-way quantum computing. They give physical insight into the observation in earlier works that various steering criteria vanish when the noise in a channel passes the threshold for secure quantum key distribution and quantum computation.⁹

RESULTS

Quantum steering and steering criteria

EPR steering typically consists of two steps: first, Alice generates a bipartite entangled system from an entanglement source (often called an EPR source; Figure 1a). To have a concrete illustration, let us assume that this entangled state is of the form

$$|\Phi\rangle = \frac{1}{\sqrt{d}} \sum_{s=0}^{d-1} |s\rangle_{A_1} \otimes |s\rangle_{B_1} \quad (1)$$

where $|s\rangle_{A_1} = |s\rangle_{B_1} = |s\rangle_1$, where $\{|s\rangle_1 | s = 0, 1, \dots, d-1\}$ is an orthonormal basis that corresponds to bases of Alice’s measurement A_1 and Bob’s measurement B_1 . Second, Alice keeps one qudit of the entangled pair and sends the other qudit to Bob. Then, depending on Alice’s measurement result $a_1 = s$, the state of the qudit finally held by Bob can be steered into a corresponding quantum state, $|s\rangle_{B_1}$, for the result $b_1 = s$. Such remote preparation of Bob’s states can also be seen in other bases. For example, suppose that Alice and Bob’s measurements A_2 and B_2 correspond to another orthonormal basis $\{|s\rangle_2 | s = 0, 1, \dots, d-1\}$, where

¹Department of Engineering Science, National Cheng Kung University, Tainan, Taiwan; ²CEMS, RIKEN, Wako-shi, Japan and ³Department of Physics, University of Michigan, Ann Arbor, MI, USA.

Correspondence: C-M Li (cmli@mail.ncku.edu.tw)

Received 18 January 2016; revised 21 April 2016; accepted 24 May 2016

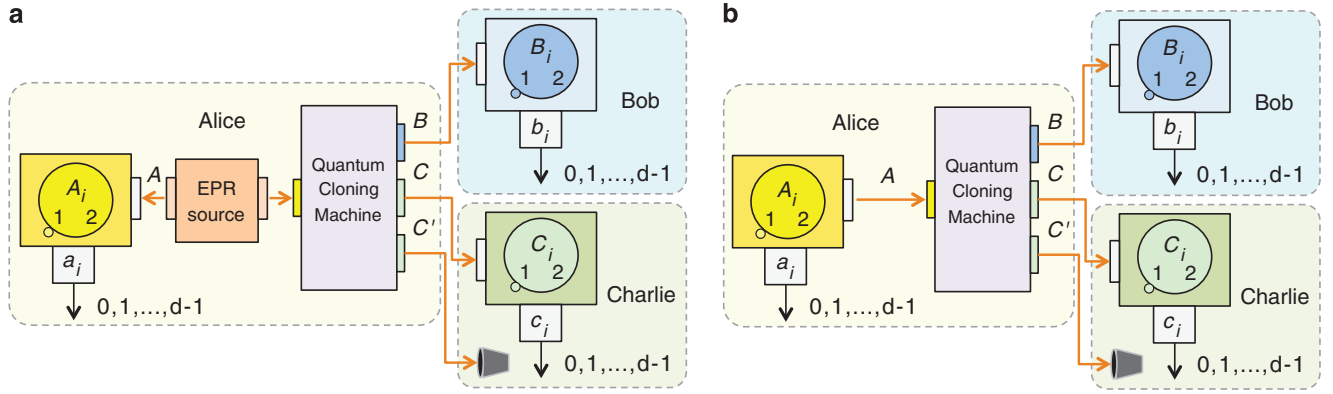

Figure 1. Cloning quantum steering. **(a)** Einstein–Podolsky–Rosen (EPR) steering. Alice creates maximally entangled pairs $|\Phi\rangle$ (1) from an EPR source. She keeps one qudit (A) and sends the other qudit of the pair into a universal cloning machine. The cloning machine, assisted by ancilla qudits (not shown), creates a four-partite composite state (3). After cloning, the qudit B is sent to Bob and the qudit C, together with the ancilla C', is sent to Charlie. Each of the three parties has an apparatus to implement two complementary measurements m_i for $m = A, B, C$ and $i = 1, 2$. Their measurement results $n_i \in \{0, 1, \dots, d-1\}$ for $n = a, b, c$ are then used to certify EPR steering of the subsystems (A, B) and (A, C) using a steering criterion (2). **(b)** Single-system (SS) steering: A qudit with the state $|s\rangle_{A_i}$ is sent from Alice to a cloning machine. Here $|s\rangle_{A_i}$ is a post-measurement state of some initial qudit (not shown) under the measurement A_i for $i = 1, 2$. A tripartite composite system is then created by the cloning machine, and the qudit B is sent to Bob and the qudit C, together with the ancilla C', is sent to Charlie. The measurement apparatus used by each party are the same as the devices used in the case of EPR steering. They can also use a steering criterion (2) to identify the SS steering of the subsystems (A, B) and (A, C).

$|s\rangle_2 = 1/\sqrt{d} \sum_{k=0}^{d-1} \exp(i\frac{2\pi}{d}sk) |k\rangle_1$, the state vector of $|\Phi\rangle$ represented in this basis is of the form $|\Phi\rangle = 1/\sqrt{d} \sum_{s=0}^{d-1} |s\rangle_{A2} \otimes |d-s\rangle_{B2}$, where $|s\rangle_{A2} = |s\rangle_{B2} = |s\rangle_2$. It is clear that Bob's outcome b_2 will respond to Alice's outcome a_2 , which satisfies $a_2 + b_2 \equiv 0$ where \equiv denotes equal module d . Such dependence can be made manifest by the conditional entropy $H(B_1|A_1) = H(B_2|A_2) = 0$, where $H(B_i|A_i) = -\sum_{a_i=0}^{d-1} P(a_i) \sum_{b_i=0}^{d-1} P(b_i|a_i) \log_2 P(b_i|a_i)$. In practical experiments, the marginal probabilities $P(a_i)$ and the conditional probabilities $P(b_i|a_i)$ can, in principle, be measured to explicitly consider this dependence.

This description of EPR steering can be directly mapped to single-system or temporal steering and *vice versa* (see Li *et al.*⁹ for detailed discussions). As depicted in Figure 1b, first, Alice prepares a qudit with the state $|s\rangle_{A_i}$ by performing complementary measurements A_1 or A_2 on an initial state. Second, Alice sends the prepared qudit to Bob. Then, she can steer the state Bob holds $|s\rangle_{B_i}$ ($|s\rangle_{B_i} = |s\rangle_{A_i}$ for the ideal case) into other quantum state by, for example, asking Bob, via a classical channel, to perform a unitary transformation on $|s\rangle_{B_i}$.

In practical situations, demonstrations of both EPR steering and SS steering are imperfect. Environmental noise, or randomness introduced by an eavesdropper, can affect both the quantum source for creating $|\Phi\rangle$ and $|s\rangle_{A_i}$ and the properties of the state during its transmission from Alice to Bob. In addition, in its information task formulation, Bob also does not trust Alice nor her measurement apparatus, and wishes to verify whether she is truly steering his state. Hence, it is important to have an objective tool that can certify the ability of Alice to steer the states of the particles eventually held by Bob. Here, we describe and verify quantum steering in terms of the mutual information between measurement results of Alice and Bob $I_{A_i B_i} = H(B_i) - H(B_i|A_i)$. Earlier works showed that if the mutual dependence between Alice and Bob's measurement results violates the bound⁹

$$\sum_{i=1}^2 I_{A_i B_i} > \log_2 d, \quad (2)$$

their dependence is stronger than the correlation between Bob's outcomes and the results derived from unsteerable states alone, verifying Alice's ability to steer Bob's state. As shown in Li *et al.*⁹ it is worth noting that the entropic steering criteria (2) are applicable to both EPR steering and SS steering. One difference between

them is that $P(b_i|a_i)$ for SS steering are derived from measurements on single systems where a_i and b_i are taken at two different times.

No-cloning of quantum steering

Suppose that Alice has an entanglement source to create pairs of qudits $|\Phi\rangle$. One qudit of the entangled pair is sent to a universal cloning machine and the other qudit (A) is kept by Alice; Figure 1a. After passing through the cloning machine, two new qudits are created, and the state of the total system becomes

$$|\phi\rangle_{ABCC'} = \sum_{j,k=0}^{d-1} \sqrt{\lambda_{jk}} |\phi_{jk}\rangle_{AB} |\phi_{j,d-k}\rangle_{CC'}. \quad (3)$$

The qudit B is sent to Bob, whereas the qudits C and C' are sent to a third party Charlie. The two-qudit state vectors $|\phi_{jk}\rangle_{AB}$ and $|\phi_{j,d-k}\rangle_{CC'}$ are described by

$$\begin{aligned} |\phi_{jk}\rangle_{mn} &= (I \otimes U_{jk}) |\Phi\rangle \\ &= \frac{1}{\sqrt{d}} \sum_{s=0}^{d-1} \exp(i\frac{2\pi}{d}sk) |s\rangle_{m1} |s+j\rangle_{n1}, \end{aligned} \quad (4)$$

for $(m, n) = (A, B), (C, C')$, where I denotes the identity operator, $U_{jk} = \sum_{s=0}^{d-1} \exp(i2\pi sk/d) |s+j\rangle_{n1n1} \langle s|$ and $|s\rangle_{m1} = |s\rangle_{n1} = |s\rangle_1$. The state of Alice's and Bob's qudits is

$$\rho_{AB} = \sum_{j,k=0}^{d-1} \lambda_{jk} |\phi_{jk}\rangle_{ABAB} \langle \phi_{jk}|, \quad (5)$$

where λ_{jk} denotes the probability of observing $|\phi_{jk}\rangle_{AB}$. The mutual information of Alice's and Bob's measurement results derived from their measurements A_i and B_i on ρ_{AB} is

$$I_{A_i B_i} = \log_2 d - \sum_{t=0}^{d-1} q_t^i \log_2 \frac{1}{q_t^i}, \quad (6)$$

where $q_t^1 = \sum_{k=0}^{d-1} \lambda_{tk}$ and $q_t^2 = \sum_{j=0}^{d-1} \lambda_{j,d-t}$. The variables q_t^i first introduced in Sheridan and Scarani¹⁰ are the probabilities of finding $b_i - a_i = t$ or $b_i - a_i = t - d$ for $t = 0, 1, \dots, d-1$. The sum of mutual information under two measurement settings is then

$$\sum_{i=1}^2 I_{A_i B_i} = 2 \log_2 d - \sum_{i=1}^2 H(q_i^t). \quad (7)$$

To determine the mutual information of Alice's and Charlie's measurement results $I_{A_i C_i}$, we first consider the mutual dependence between a_i and the results derived from measurements on the subsystem composed of Charlie's qudit C and the ancilla C' by their mutual information $I_{A_i(C_i C'_i)}$. It is clear that

$$I_{A_i C_i} \leq I_{A_i(C_i C'_i)}. \quad (8)$$

In addition, the mutual information $I_{A_i(C_i C'_i)}$ is constrained by the Holevo bound by

$$I_{A_i(C_i C'_i)} \leq S(\rho_{CC'}) - \sum_{a_i=0}^{d-1} P(a_i) S(\rho_{CC'|a_i}). \quad (9)$$

$S(\rho_{CC'})$ is the von-Neumann entropy of the state $\rho_{CC'} = \sum_{j,k=0}^{d-1} \lambda_{jk} |\phi_{j,d-k}\rangle_{CC'} \langle \phi_{j,d-k}|$. It can be explicitly represented by

$$S(\rho_{CC'}) = \sum_{j,k=0}^{d-1} -\lambda_{jk} \log_2 \lambda_{jk} \equiv H(\lambda). \quad (10)$$

The state $\rho_{CC'|a_i}$ is the reduced state conditioned when Alice obtains the result a_i . Now, we use the method presented in Sheridan and Scarani¹⁰ to find the upper bound in equation (9). The von-Neumann entropy of this state can be shown as $S(\rho_{CC'|a_i}) = \sum_{t=0}^{d-1} q_i^t \log_2 1/q_i^t \equiv H(q_i^t)$. To derive the upper bound of $I_{A_i(C_i C'_i)}$ by minimising the difference between $S(\rho_{CC'})$ and $\sum_{a_i=0}^{d-1} P(a_i) S(\rho_{CC'|a_i})$, we substitute $\lambda_{j,d-k} = f(j,k) q_i^t$ into $q_i^t = \sum_{j=0}^{d-1} \lambda_{j,d-t}$ where $\sum_{k=0}^{d-1} f(j,k) = 1$, and then obtain $q_i^t = \sum_{k=0}^{d-1} f(t,k) q_i^t$. For each t , all $f(t,k) = q_i^t$ implies the minimum of the difference. Then, we have

$$H(\lambda) = H(q_i^t) + \sum_t q_i^t H(f(t)) = H(q_i^t) + H(q_2^t). \quad (11)$$

With equations (8), (9) and (11), the upper bound of the mutual information $I_{A_i C_i}$ is shown as

$$I_{A_i C_i} \leq H(q_i^t) + H(q_2^t) - H(q_i^t), \quad (12)$$

which implies that

$$\sum_{i=1}^2 I_{A_i C_i} \leq \sum_{i=1}^2 H(q_i^t). \quad (13)$$

Hence, combining equation (7) with equation (13), we eventually derive the following relationship between the mutual information of Bob's and Charlie's systems with Alice's

$$\sum_{i=1}^2 I_{A_i C_i} + \sum_{i=1}^2 I_{A_i B_i} \leq 2 \log_2 d. \quad (14)$$

This criterion (14) provides a basis to investigate how EPR steering is shared between two copies of a qudit of a maximally entangled pair. When the correlation between the qudits shared by Alice and one of the two parties, say Charlie, is certified by the steering criteria (2), it is clear that the mutual dependence between qudits shared by Alice and Bob will not be stronger than an unsteerable state. Hence, EPR steering can be identified in only one of the copy subsystems. This analysis of the behaviour of EPR steering subject to cloning can be directly applied to SS steering as well; see Methods section.

Securing quantum information processing

The steerability of Alice over Bob's or Charlie's qudits, as certified by the steering criteria (2), implies that the mutual dependence

between them is stronger than the mimicry that an unsteerable state can provide. In addition, such steering cannot be shared with a third party by using a universal cloning machine. Two direct applications to quantum information are illustrated as follows.

- (i) If a sender (Alice) and a receiver (Bob) confirm that their measurement results are classified as steerable, according to the criterion (2), they can be convinced that an eavesdropper (Charlie) who uses a cloning machine for coherent attacks cannot produce states that can be steered by the sender. This is because the mutual information between Alice and Bob is larger than the mutual information shared between Alice and the eavesdropper, Charlie. Thus, they can use privacy-amplification techniques on their shared measurement outcomes to generate a secure key. Thus, the no-cloning of quantum steering verified by equation (2) shows that ruling out false steering secures channels against cloning-based attacks when implementing quantum key distribution.
- (ii) As shown in Li *et al.*,⁹ steering quantum systems is equivalent to performing quantum computation. No-cloning of steering provides a strict proof to show that the observation of quantum steering guarantees faithful implementation of a quantum computing implementation in the presence of uncharacteristic measurements and cloning-based attacks.

DISCUSSION

We investigated how quantum steering is cloned by a universal cloning machine and shared between two copy subsystems. We showed that it is impossible to observe quantum steering, as described by the mutual information criterion (2), in the two copies at the same time. This no-cloning of quantum steering ensures secure quantum key distribution and faithful quantum gate operations of arbitrary computing size against cloning-based attacks. Our results motivate several open questions. Is the no-cloning of quantum steering applicable to the situation of genuine multipartite multidimensional EPR steering? If this is the case, then such high-order steering would serve as a source for reliable multipartite quantum information processing, such as quantum secret sharing. In addition to high-order steering, does one-way steering possess this feature of no-cloning? If we use a steering measure instead of an entropic criterion (2), could the partial power of quantum steering in terms of the units of a steering quantifier be copied by the cloning machine? Could the total quantity of steering be conserved after cloning?

Finally, it is interesting to connect our results with other approaches, such as the principle of monogamy of certain quantum correlations.^{11,12} In particular, the principle of the monogamy of temporal steering, shown in the work by Bartkiewicz *et al.*¹² (see equation (5) therein), is consistent with our results, and suggests that our criteria can also be interpreted as a monogamy relation in the entropic form. However, whether such a result can provide a relation in the form of Coffman–Kundu–Wootters monogamy inequality (see, for example, equation (1) in Kay *et al.*¹¹) still needs further investigation. In addition, He *et al.*¹³ have shown that two-way steering is required to overcome the no-cloning threshold for secure teleportation. This relationship, between no-cloning and EPR steering, also suggests a principle of no-cloning for the correlations used for teleportation. Their quantum information–task-oriented method, to investigate the relationship between the no-cloning theorem and steering, indicates that it may be interesting, in future work, to consider the security threshold for secure quantum teleportation derived from our input–output scenario for cloning quantum steering, and to compare this condition on fidelity with their criterion.¹³

METHODS

No-cloning of SS steering

As illustrated in Figure 1b, after operating the cloning machine on a single system sent from Alice, the state $|s\rangle_{Ai}$ becomes

$$|\phi\rangle_{BCC'} = \sum_{j,k=0}^{d-1} \sqrt{\lambda_{jk}} |\phi_{jk}\rangle_B |\phi_{j,d-k}\rangle_{CC'}, \quad (15)$$

where

$$|\phi_{jk}\rangle_B = U_{j,k}|s\rangle_{Bi}. \quad (16)$$

(note that $|\phi_{00}\rangle_B = |s\rangle_{Ai}$). The state of Bob's qudit is then $\rho_B = \sum_{j,k=0}^{d-1} \lambda_{jk} |\phi_{jk}\rangle_{BB} \langle\phi_{jk}|$. With this reduced state, we obtain the mutual information $I_{A_i B_i}$ (6). When considering the mutual information $I_{A_i C_i}$, it is easy to find that the connection between A and CC' here can be mapped to the case of EPR steering. There are no differences between the states $S(\rho_{CC'}|a_i)$ together with $S(\rho_{CC'})$ in these two steering cases. Then, we arrive again at the result of a constraint on mutual information for subsystems (14). Hence, the SS steering can be observed in only one of the copy subsystems.

ACKNOWLEDGEMENTS

This work is partially supported by the Ministry of Science and Technology, Taiwan, under Grant Numbers MOST 104-2112-M-006-016-MY3 and No. MOST-104-2221-E-006-132-MY2. This work is partially supported by the RIKEN iTHES Project, the MURI Center for Dynamic Magneto-Optics via the AFOSR award number FA9550-14-1-0040, the IMPACT program of JST and a Grant-in-Aid for Scientific Research (A). N.L. is partially supported by the FY2015 Incentive Research Project. N.L. and F.N. acknowledge the support of a grant from the John Templeton Foundation.

CONTRIBUTIONS

C.-Y.C. and C.-M.L. devised the basic model. C.-Y.C., N.L., T.-L.L. and C.-M.L. established the final framework. N.L., F.N. and C.-M.L. wrote the paper with contributions from all authors.

COMPETING INTERESTS

The authors declare no conflict of interest.

REFERENCES

1. Schrödinger E. Discussion of probability relations between separated systems. *Math. Proc. Cambridge Philos. Soc.* **31**, 555–563 (1935).
2. Einstein, A., Podolsky, B. & Rosen, N. Can quantum-mechanical description of physical reality be considered complete? *Phys. Rev.* **47**, 0777–0780 (1935).
3. Wiseman, H. M., Jones, S. J. & Doherty, A. C. Steering, entanglement, nonlocality, and the Einstein-Podolsky-Rosen paradox. *Phys. Rev. Lett.* **98**, 140402 (2007).
4. Reid, M. D. *et al.* Colloquium: the Einstein-Podolsky-Rosen paradox: from concepts to applications. *Rev. Mod. Phys.* **81**, 1727–1748 (2009).
5. Wootters, W. K. & Zurek, W. H. A single quantum cannot be cloned. *Nature* **299**, 802–803 (1982).
6. Dieks, D. Communication by EPR devices. *Phys. Lett. A* **92**, 271–272 (1982).
7. Bužek, V. & Hillery, M. Quantum copying: Beyond the no-cloning theorem. *Phys. Rev. A* **54**, 1844–1852 (1996).
8. Scarani, V., Iblisdir, S., Gisin, N. & Acín, A. Quantum cloning. *Rev. Mod. Phys.* **81**, 1225–1256 (2005).
9. Li, C.-M., Chen, Y.-N., Lambert, N., Chiu, C.-Y. & Nori, F. Certifying single-system steering for quantum-information processing. *Phys. Rev. A* **92**, 062310 (2015).
10. Sheridan, L. & Scarani, V. Security proof for quantum key distribution using qudit systems. *Phys. Rev. A* **82**, 030301 (2010).
11. Kay, A., Kaszlikowski, D. & Ramanathan, R. Optimal cloning and singlet monogamy. *Phys. Rev. Lett.* **103**, 050501 (2009).
12. Bartkiewicz K., Černoch A., Lemr K., Miranowicz A. & Nori F. Temporal steering and security of quantum key distribution with mutually-unbiased bases against individual attacks. arXiv:1503.00612v4 (2016).
13. He, Q., Rosales-Zárate, L., Adesso, G. & Reid, M. D. Secure continuous variable teleportation and Einstein-Podolsky-Rosen steering. *Phys. Rev. Lett.* **115**, 180502 (2015).



This work is licensed under a Creative Commons Attribution 4.0 International License. The images or other third party material in this article are included in the article's Creative Commons license, unless indicated otherwise in the credit line; if the material is not included under the Creative Commons license, users will need to obtain permission from the license holder to reproduce the material. To view a copy of this license, visit <http://creativecommons.org/licenses/by/4.0/>

© The Author(s) 2016