

# Tools, Installation, Operation and Maintenance

Safe, efficient operation of any product is inherently dependent upon its proper installation. In this section the preparation and assembly of low, medium and high pressure connections is explained. Also covered is the assembly procedure for medium and high pressure anti-vibration collet gland assemblies.

Correct installation procedures are further promoted by providing dimensional information associated with a variety of Parker Autoclave Engineers tube connections as well as the torque required to properly seat numerous Parker Autoclave Engineers components. Several tools developed by Parker Autoclave Engineers are presented to help accomplish proper valve, fitting and tubing installation and maintenance.

When installing or maintaining any pressure component, common practice dictates the use of proper safety equipment at all times.



**Tools, Installation, Operation and Maintenance**



[www.autoclave.com](http://www.autoclave.com)

## Parker Autoclave Engineers Speedbite Connections

**Fast, Positive Sealing for Pressures up to 15,000 psi\* (1034 bar)**

1. Cut tubing to length and deburr. Allow extra length for proper engagement (per table below).

Outside Diameter Tube Size inches (mm)	Extra Allowance** for Engagement inches (mm)
1/16 (1.59)	0.50 (12.70)
1/8 (3.18)	0.50 (12.70)
1/4 (6.35)	0.75 (19.05)
3/8 (9.53)	0.75 (19.05)
1/2 (12.70)	0.88 (22.35)

2. Lubricate male threads. (Lubrication not necessary if tube nut has Bonded Dry-Film Lubricant.) Slip gland and sleeve onto tubing.

*Note: Be sure to remove gland and sleeve from components and slide them onto the tubing before inserting the tubing into the components. Make sure larger end of sleeve is toward gland.* Push tubing into valve or fitting until it bottoms. If process tolerable, a slight amount of inert grease on the nose of the compression sleeve will improve sealability.

3. TIGHTEN GLAND UNTIL SLEEVE BEGINS TO GRIP TUBING.

4. Note starting position of wrench. Tighten gland approximately 1-1/4 turns for the SW and 1/8" W connection. For 1/4" and 1/2" W connections tighten glands approximately 1 turn, for adapter approximately 1/8 turn.

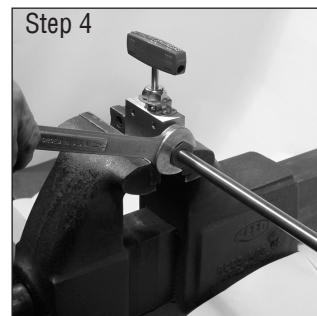
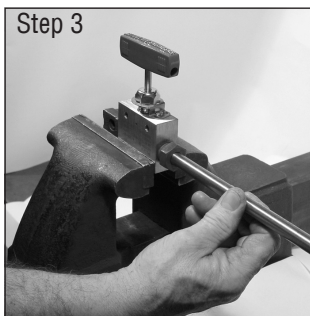

### Complete Connection

The illustration below shows the condition of sleeve and tubing after completion of "sleeve seating." The sleeve has cut into the tubing as it moved forward into the tapered seat, upsetting material ahead of it and establishing a shoulder on the tubing to provide positive mechanical support for the tubing end-load. A properly seated sleeve cannot be displaced back and forth along the tubing but may be rotated around the tubing.

### Reassembly

To reassemble a connection, insert tubing with sleeve and gland into valve or fitting. Tighten gland "finger-tight". Tighten gland with a wrench approximately 3/8 of a turn for a gas-tight seal. After frequent reassemblies, it may take less than 3/8 turn to effect a gas-tight seal, and as little as 1/8 of a turn may be sufficient.

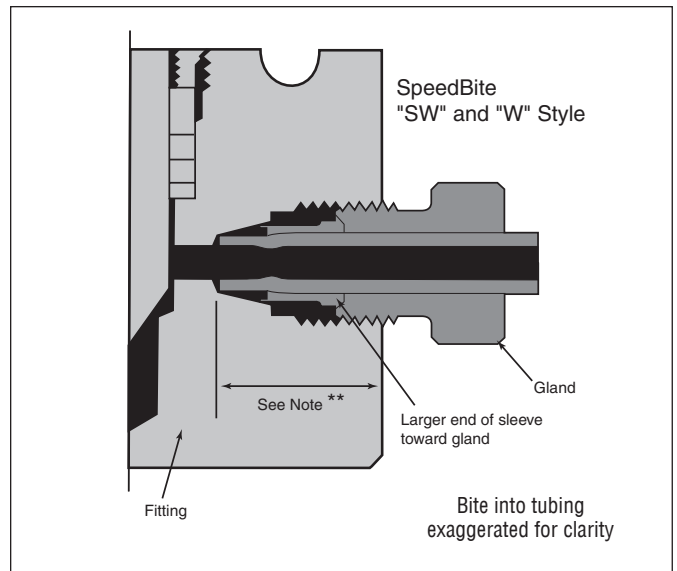

\* No special torque wrenches or mandrels required.

\*\* Distance tubing protrudes into connection from face of fitting.

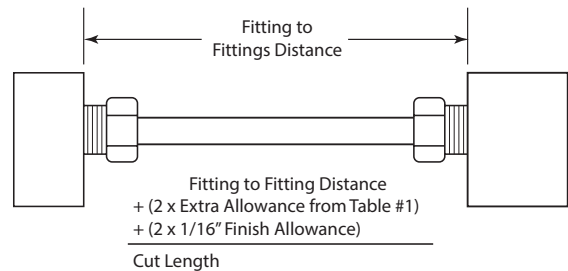

Determine Tube Length

Fully annealed tubing with proper outside diameter tolerances is recommended for these connection components.

## Manual Coning & Threading Tools

Parker Autoclave Engineers manufactures a manual coning and threading tool for optimum performance with tubing sizes up to 9/16" (14.3 mm) outside diameter. These precision quality manual tools permit on-site end preparation for Parker Autoclave Engineers medium and high pressure tubing installations. One coning and one threading tool with optional sizes of collets, blades, dies and guide bushings eliminates the need of multiple tools for different size tubing.

Interchangeable collets for each size tubing provides proper centering of tubing. The cutting feed arrangement permits the operator to control the length of the cut. Interchangeable tool steel cutting blades are used in pairs to assure more accurate and faster coning. They are designed to square-off and finish the tube as the cone is completed. There is a provision for applying metal cutting lubricants to the cutting zone.



**For coning tool with optional support arm (For holding in vise) and chip/oil catch reservoir, add RS to suffix of model number.**  
Example: **MCTM4-RS**

For threading operations the threading die holder is designed to hold the appropriate die for any of the standard Parker Autoclave Engineers tubing sizes through 9/16" (14.3 mm) outside diameter. Interchangeable guide bushings properly guide the tool for accurate thread cutting.

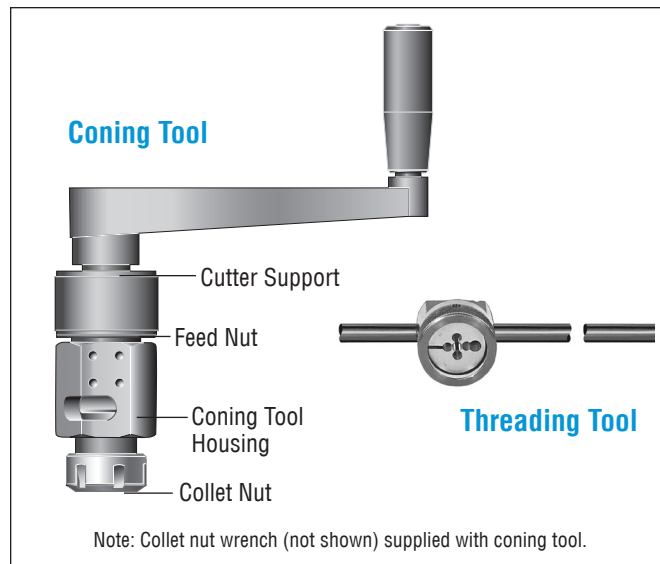

	Tube Size		Coning Tools and Components Catalog Number			Threading Tools and Components Catalog Number				
	Outside Diameter in. (mm)	Inside Diameter in. (mm)	Tool with Collet & Blades	Collet	Coning Blades (set of 2)	Tool with Die & Bushing	Tool Only	Threading Die		Guide Bushing
								Order No.	Size-type*	
Parker AE Medium Pressure	1/4 (6.35)	.109 (2.77)	MCTM4	90248	101F-1577	402A	402	P-0214	1/4-28	1010-0343
	3/8 (9.53)	.203 (5.16)	MCTM6	90250	101F-1601	402C	402	P-0215	3/8-24	1010-0344
	†9/16 (14.3)	.312 (7.92)	MCTM920	90251	1010-5218	402E	402	P-0216	9/16-18	1010-0345
	9/16 (14.3)	.359 (9.12)	MCTM910	90251	101A-1897	402E	402	P-0216	9/16-18	1010-0345
Parker AE High Pressure	1/4 (6.35)	.083 (2.11)	MCTH4	90248	101F-3939	402A	402	P-0214	1/4-28	1010-0343
	5/16 (7.92)	.062 (1.57)	MCTH5	90249	101F-3939	402B	402	P-0205	5/16-24	1030-0343
	3/8 (9.53)	.125 (3.18)	MCTH6	90250	101F-1578	402C	402	P-0215	3/8-24	1010-0344
	9/16 (14.3)	.188 (4.78)	MCTH960	90251	1010-0883	402E	402	P-0216	9/16-18	1010-0345
	9/16 (14.3)	.250 (6.35)	MCTH940	90251	101C-7214	402E	402	P-0216	9/16-18	1010-0345

Options: **Cutting Oil: P-8784**  
**90286: Instructions**

**MCT-SA: Support Arm Assembly**  
**MCT-RES: Reservoir Assembly**

\* All threads for Parker AE medium pressure and high pressure tubing are LH national fine (class 2). † 9/16 (14.3) x .312 (7.92) ID 40,000 psi (2758 bar), use MCTM920.

Note: Manual coning and threading tools for 3/4" (19.1 mm) and 1" (25.4 mm) outside diameter medium pressure tubing are not available. Model AEGCTM-2 Power Coning-and-Threading Machine is recommended for this tubing. A minimum of 3" (76 mm) straight length is required to perform coning and threading operation with manual coning tool.

## Coning and Coning and Threading Tool Kits

Parker Autoclave Engineers offers coning kits as well as coning and threading tool kits. Each kit consists of the required tools and other items necessary for your coning or coning and threading needs. All kit items are placed in a hand-carry tool case with top tray. The coning tools supplied in the tool kits come complete with the support arm and chip/oil reservoir.

### Coning and Threading Kit:

Included with all kits: Coning tool assembly, three collets, collet nut wrench, three sets of coning blades, tool box with tray, de-burring tool, one quart of cutting oil, 3/32 Allen wrench, four spare set screws, threading tool, three guide bushings, three threading dies, and laminated instruction sheet.

### Medium pressure kit

- KMCT-MT** Coning tool with support arm and reservoir
- 1/4, 3/8 and 9/16" collets
- 1/4, 3/8 and 9/16" blades
- (9/16" blades for 20,000 psi tubing only)
- Threading tool
- 1/4, 3/8 and 9/16" guide bushing
- 1/4, 3/8 and 9/16" dies

### High pressure kit

- KMCT-HT** Coning tool with support arm and reservoir
- 1/4, 3/8 and 9/16" collets
- 1/4, 3/8 and 9/16" blades
- (5/16" collets not included)
- (9/16" blades for 60,000 psi tubing only)
- Threading tool
- 1/4, 3/8 and 9/16" guide bushing
- 1/4, 3/8 and 9/16" dies



**Note:** Additional blades available for other sizes of tubing. See manual coning and threading tool on page 3 for sizes and part numbers.

## Coning and Threading Installation

### Manual Kit:

1. **Fig. 1** Cut tubing to length and square off the end as close to the required length as possible. Allow extra length for proper engagement into the connection as listed in Table 1. A small amount of extra length should be allowed to finish the end of the tube, but excessive amounts require additional cutting time and premature blade wear. **Note:** When cutting tubing with abrasive cut off wheel, tubing should not be over heated affecting material properties.

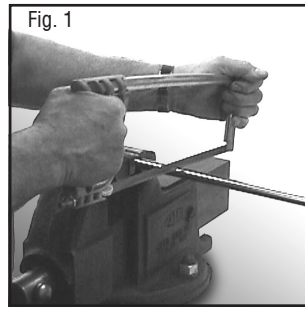

2. Install the collet and collet nut into the bottom of the coning tool housing. Remove the cutter support feed nut from the coning tool housing and install the cutters. This can be done by backing out the four set screws in the cutter support. **Note:** When installing new blades, be sure the blades are flat against the holder. There should be no space between the blades and the holder.

TABLE 1

	Connection Tubing Size	Type OD x ID	Engagement Allowance in (mm)
Medium Pressure	SF250CX	1/4 x .109	.55 (14.0)
	SF375CX	3/8 X .203	.69 (17.6)
	SF562CX20	9/16 x .312	.84 (21.3)
	SF562CX10	9/16 x .359	.84 (21.3)
	SF750CX20	3/4 x .438	1.00 (25.4)
	SF750CX10	3/4 x .516	1.00 (25.4)
	SF1000CX20	1 x .562	1.44 (36.6)
	SF1000CX10	1 x .688	1.28 (32.5)
High Pressure	SF1500CX10	1-1/2 x .937	1.88 (47.6)
	*F250C100	1/4 x .083	1.18 (30.0)
	F250C	1/4 x .083	.50 (12.7)
	F312C150	5/16 x .062	1.18 (30.0)
	F375C	3/8 x .125	.69 (17.5)
	*F375C100	3/8 x .125	1.10 (28.0)
	F562C	9/16 x .188	.84 (21.3)
	F562C40	9/16 X .250	.81 (20.6)
	F562C40-312	9/16 x .312	.80 (20.32)
	F1000C43	1 x .438	1.62 (41.1)

Note: 9/16 100k same as F562C - \*Connection used in F312C150

TABLE 2

Medium Pressure Tubing			High Pressure Tubing		
	Cone Length inches (mm)	No. of Turns	Tube O.D. (inches)	Cone Length inches (mm)	No. of Turns
1/4"	0.11 (2.79)	2	1/4"	0.13 (3.30)	3
3/8"	0.13 (3.30)	3-1/2	5/16"	0.19 (4.83)	3-1/2
9/16"(CX-20)	0.16 (4.06)	3	3/8"	0.16 (4.06)	3
9/16"(CX-10)	0.13 (3.30)	2-1/2	9/16"	0.28 (7.11)	5-1/2
			9/16"(C40)	0.21 (5.33)	4-1/2

Manual coning and threading tools are not available for 3/4" and 1" tubing, see page 11 Coning and Threading Machine.

All dimensions for reference only and subject to change.

3. **Fig. 2** Place the coning tool housing (or optional support arm), without the feed nut/cutter support assembly, in a vise. The vise should be equipped with soft jaws, and the housing should be placed in the vise to allow lubricant to flow to the cutters and cone.

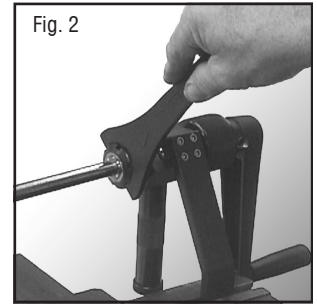

4. **Fig. 2** Slide the tubing through the collet until the end of the tube appears in the coning tool housing window. Line the end of the tube with the edge of the window and tighten the collet nut firmly in place using the collet nut wrench (see Table 2).

5. **Fig. 3** Install the feed nut/cutter support assembly into the coning tool housing. Rotate the feed nut clockwise until the top of the cutters just contact the top of the tube. **Do not** rotate the feed nut any further at this point.

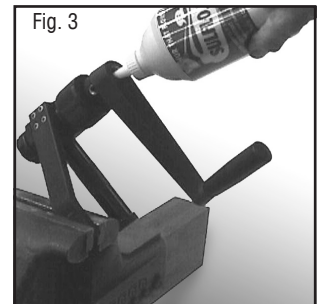

6. **Fig. 3** Apply cutting oil through the lubricant opening in the end of the cutter holder or directly through the housing window. A medium weight high sulphur content cutting fluid is recommended. Use the cutting oil freely during the coning operation.

7. a. The distance the feed nut travels from its start position can be used to gauge the amount of travel to properly cone the tube. The amount of travel is shown in Table 2 and is labeled "Cone Length".

b. Another method to determine proper cone length is to count the number of turns of the feed nut. The number of turns is listed in Table 2 under the heading "Number of Turns". This includes enough advancement of the feed nut to face off the tube. This assumes the tube is cut to length in accordance with these instructions. The feed nut is supplied with a position indicator (drilled hole) to help determine the number of turns.

8. Rotate the handle in a clockwise direction while simultaneously **slowly** turning the feed nut in a clockwise direction. Rotate the feed nut slowly and evenly to smoothly cone the tube. Loosen collet nut, remove tubing and visually inspect the cone. Use deburring tool to remove any burr on inside edge of tube after coning.

### Manual Threading:

9. **Fig. 4** Clamp the tubing in a soft jaw vise. Do not over tighten. Slide the threading tool over the tube through the guide bushing.

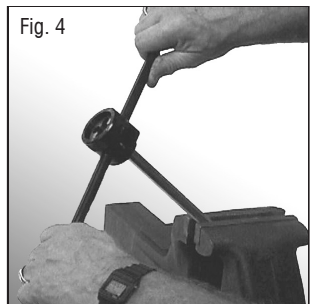

10. Apply a medium weight, high sulphur cutting oil to threading area.

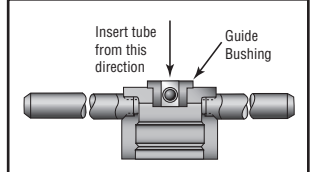

11. Apply pressure to the top of the threading tool to start the cutting action. The threads are left handed, so turn the threader **counterclockwise** to thread the tube. The threading tool may need to be periodically rotated clockwise to break and discharge metal chips. Apply lubricant freely during the threading process. **Note:** The lead in chamfer (larger chamfer) on the die flutes toward guide bushing.

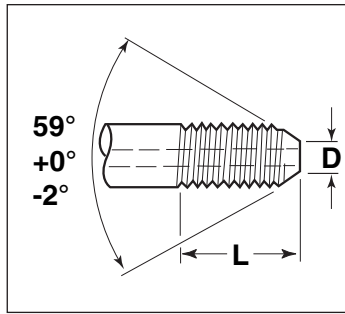

12. Continue to rotate die holder counterclockwise while applying cutting oil generously throughout the process until threads of the following lengths have been cut. See Table 4.

13. After tube is coned, threaded and deburred, check for proper thread fit and length with a new collar of the proper size. **Note:** Remember to flush all tubing prior to installation with a fluid that is compatible with the process fluid being used.

TABLE 3

Male Connection Type	Tube Size Outside Diameter X Inside Diameter inches (mm)	Dimensions inches (mm)		Thread size* and type (inches)
		D	L (max)	
SM250CX	1/4" x 0.109 (6.35 x 2.77)	0.141 (3.58)	0.344 (8.74)	1/4" - 28
SM375CX	3/8" x 0.203 (9.53 x 5.16)	0.25 (6.35)	0.438 (11.13)	3/8" - 24
SM562CX20	9/16" x 0.312 (14.29 x 7.92)	0.406 (10.31)	0.500 (12.70)	9/16" - 18
SM562CX10	9/16" x 0.359 (14.29 x 9.12)	0.438 (11.13)	0.500 (12.70)	9/16" - 18
SM750CX20	3/4" x 0.438 (19.05 x 11.13)	0.562 (14.27)	0.625 (15.88)	3/4" - 16
SM750CX10	3/4" x 0.516 (19.05 x 13.11)	0.578 (14.68)	0.625 (15.88)	3/4" - 16
SM1000CX20	1" x 0.562 (25.4 x 14.27)	0.719 (18.26)	0.781 (19.84)	1" - 14
SM1000CX10	1" x 0.688 (25.4 x 17.48)	0.812 (20.62)	0.781 (19.84)	1" - 14
SM1500CX	1-1/2" x 0.937 (38.10 x 23.78)	1.062 (26.97)	1.000 (25.40)	1-1/2" - 12
M250C	1/4" x 0.083 (6.35 x 2.10)	0.125 (3.18)	0.562 (14.27)	1/4" - 28
M250C100 (see note)	1/4" x 0.083 (6.35 x 2.10)	0.125 (3.18)	0.625 (15.88)	1/4" - 28
M312C150	5/16" x 0.062 (7.94 x 1.57)	0.125 (3.18)	0.687 (17.45)	5/16" - 24
M375C100 (see note)	3/8" X 0.125 (9.53 x 3.18)	0.219 (5.56)	0.625 (15.88)	3/8" - 24
M375C	3/8" x 0.125 (9.53 x 3.18)	0.219 (5.56)	0.75 (19.05)	3/8" - 24
M562C	9/16" x 0.187 (14.29 x 4.78)	0.281 (7.14)	0.938 (23.83)	9/16" - 18
M562C40	9/16" x 0.250 (14.29 x 6.35)	0.312 (7.92)	0.938 (23.83)	9/16" - 18
M562C40-312	9/16" x .312 (14.29 x 7.92)	0.406 (10.31)	0.940 (23.88)	9/16" - 18
M1000C43	1" x 0.438 (25.4 x 11.13)	0.562 (14.27)	0.91 (23.11)	1" - 14

\*Thread is left-hand national fine (Class 2). All dimensions for reference only and subject to change.

**NOTE:** M250C100 and M375C100 used in F312C150 connection at 100,000 psi (6895 bar).

## Approximate Number of Turns to Thread Tubing

TABLE 4

Male Connection	Number of Turns
SM250CX	7-1/2
SM375CX	8-1/2
SM562CX10/20 - M562C40-312	8
M250C	13
M250C100	13
M312C150	13
M375C100	13
M375C	15
M562C	13
M562C40	13

## Assembly and Makeup of Connection

1. Lubricate male threads of gland with a metal based thread lubricant.† Slip gland on tubing as shown and thread collar on tubing until one to two threads are exposed between collar and cone.

2. A small amount of process tolerable lubricant, such as silicone grease, on the cone tip will help with the sealing process. Insert tubing in connection, engage gland and tighten "fingertight".

3. Tighten gland with torque wrench to specified values on page 13. When tightening, the use of an additional wrench is recommended to hold the fitting.

† Copper Anti-Seize Lubricant:

P-3580 (1 pound can)  
P-3580-8 (1/2 pound can)

Moly Anti-Seize Lubricant:  
P-9766 (1 pound can)

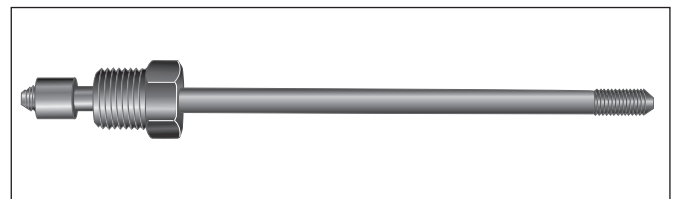

Step 1, 2

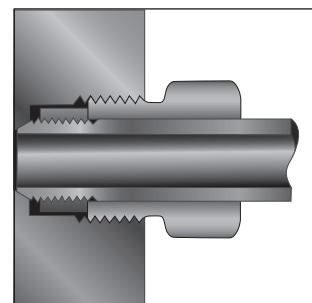

Completed Autoclave Engineers Medium Pressure Connection.

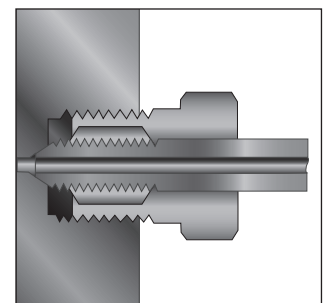

Completed Autoclave Engineers High Pressure Connection.

## QSS Assembly Procedure

**Fast, Positive Sealing for Pressures up to 15,000 psi (1034 bar)**

**1/4" & 3/8" Tubing Size (Standard setting operation)**  
**See next page for setting with hydraulic tool.**

(Setting with hydraulic tool is recommended but not required).

1. Cut tubing to length and deburr. Allow extra length for proper engagement (per table below).

Outside Diameter Tube Size inches (mm)	Extra Allowance for Engagement inches (mm)
1/4 (6.35)	0.75 (19.05)
3/8 (9.53)	0.81 (20.64)

2. Slip gland and sleeve onto tubing.

**Note:** Be sure to remove gland and sleeve from components and slide them onto the tubing before inserting the tubing into the components.

**Make sure larger end of sleeve is toward gland.**

Push tubing into valve or fitting until it bottoms. Lubricate gland nut threads to aid in assembly. If process tolerable, a slight amount of inert grease on the nose of the compression sleeve is recommended to improve sealability.

3. TIGHTEN GLAND NUT UNTIL SLEEVE BEGINS TO GRIP TUBING.

4. Note starting position of wrench.† Tighten gland nut 1-1/4 turns to complete the QSS connection.\*

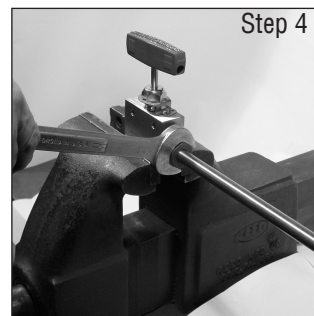
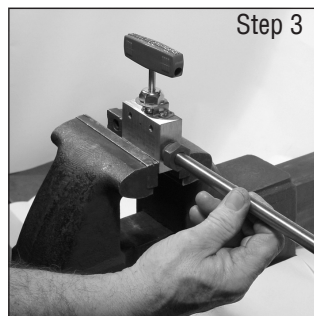
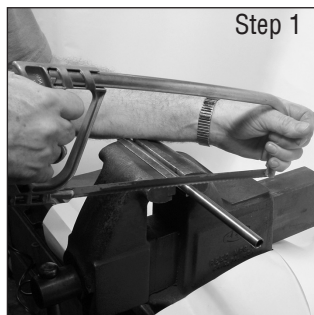

Note: Torque for QS Adapters and Plugs  
 1/4" - 10 ft. lbs.  
 3/8" - 20 ft. lbs.  
 9/16" - 45 ft. lbs.  
 3/4" - 100 ft. lbs.  
 1" - 225 ft. lbs.

Torque values can be used for both initial setting and reassembly connections. See the following page for reassembly values and ranges.

	Initial setting torque ft-lbs (NM)
1/4"	40 (54.3)
3/8"	80 (108.5)

### Completed Connection

The illustration below shows the condition of sleeve and tubing after completion of "sleeve setting." The sleeve has cut into the tubing as it moved forward into the tapered seat, upsetting material ahead of it and establishing a shoulder on the tubing to provide positive mechanical support for the tubing end-load. A properly set sleeve cannot be displaced back and forth along the tubing but may be rotated around the tubing.

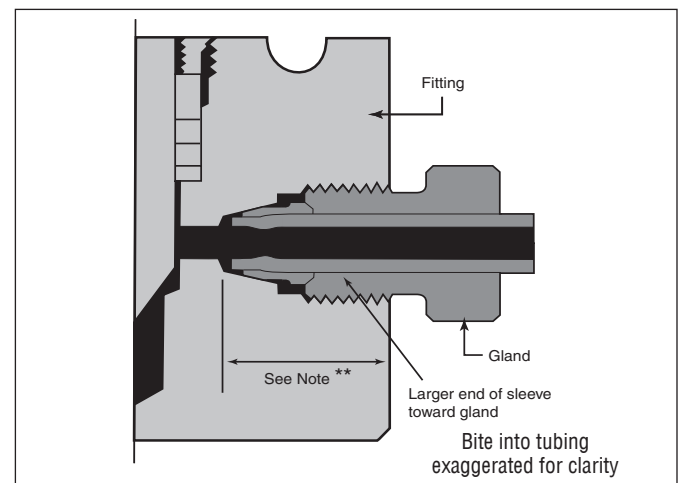

### Reassembly

To reassemble a 1/4 or 3/8 connection, insert tubing with sleeve and gland nut into valve or fitting. Tighten gland nut until the sleeve begins to grip tubing. Tighten gland with a wrench 1/4 of a turn for a gas-tight seal. After frequent reassemblies, it may take less than 1/4 turn to affect a gas-tight seal and as little as 1/8 of a turn may be sufficient.

\* No special torque wrenches or mandrels required.

\*\* Distance tubing protrudes into connection from face of fitting.

† A small blind hole on the face of the gland is provided for a starting position reference.

Parker Autoclave Engineers Medium Pressure tubing is required for these connection components.

When assembling tubing into fittings such as in rack systems, alignment of tubing is critical in connection make up. Do not force tubing into alignment with connections as bending stress will effect the sealing capability of the connections.

## QSS Assembly Procedure

**Fast, Positive Sealing for Pressures up to 15,000 psi (1034 bar)**

### Hydraulic Set Tool Assembly

1. Cut tubing to length and deburr. Allow extra length for proper engagement (per table below).

Outside Diameter Tube Size inches (mm)	Extra Allowance for Engagement inches (mm)
1/4 (6.35)	0.75 (19.05)
3/8 (9.53)	0.81 (20.64)
9/16 (14.27)	1.25 (31.75)
3/4 (19.04)	1.63 (41.28)
1 (25.40)	1.75 (44.45)

2. Slip gland nut and sleeve onto tubing. Lubricate the nose of the compression sleeve or the tapered die surface with a metal to metal lubricant. We recommend Jetlube MP-50. Make sure larger end of sleeve is toward gland nut. Push tubing into hydraulic set tool until it bottoms into the setting die. For the 1" size only, assemble the split nut (2A-1) around the tubing between the sleeve and gland with the larger counter bore towards the gland and thread into the cap. Be sure both the split nut and cap have been tightened down and neither can be moved by hand. The cap should always be flush with the top of the housing (2A-2) while the split nut will not. Skip step 3.

3. Thread gland nut into cap until the hex touches the top surface.  
4. Pressurize cylinder up to the set pressure (per table below).

**DO NOT EXCEED THE SET PRESSURE. AS WITH ALL HIGH PRESSURE EQUIPMENT, USE CAUTION DURING OPERATION. SET TOOL MAWP IS 10,000 PSI (690 BAR).**

Outside Diameter Tube Size inches (mm)	Set Pressure for Full Tubing Bite psi (bar)
1/4 (6.35) 3/8 (9.53)	4500 (310) to 5000 (344)
9/16 (14.27)	5000 (345) to 6000 (414)
3/4 (19.04)	8000 (552) to 10000 (690)
1 (25.4)	9000 (620) to 9500 (655)

Vent all pressure from hydraulic cylinder. Remove gland assembly from preset tool and inspect biting end of sleeve. Looking inside the biting end of the sleeve you should see a shoulder pushed up from the tubing material. A properly set sleeve must spin freely to achieve a seal. If the sleeve is seized in place after setting, discard and make another. **Do not set a sleeve more than once.**

5. Install gland assembly into valve/fitting. If process tolerable, a slight amount of inert grease on the nose of the compression sleeve should be used to aid sealing. Lubrication of gland threads will also aid in assembly.

### TIGHTEN GLAND NUT UNTIL SLEEVE BEGINS TO GRIP TUBING.

6. Note starting position of wrench.<sup>†</sup> Tighten gland nut 1/4 turn to complete the QSS connection. Since the mechanical bite has already been completed with the hydraulic set tool, it is permissible to vary the torque to achieve sealing.

If torque values are required, use the following:

Size (in)	Required Torque ft-lbs (Nm)	Max. Torque ft-lbs (Nm)	Torque Wrench Adapter Size	Adapter Part #
1/4"	30 (40.7)	50 (67.8)	5/8"	AE003321
3/8"	35 (47.5)	75 (101.6)	3/4"	AE003322
9/16"	90 (122.0)	175 (237)	1-3/16"	AE003324
3/4"	175 (237.3)	325 (440)	1-1/2"	AE000170
1"	375 (508.4)	635 (861)	1-3/4"	AE001067

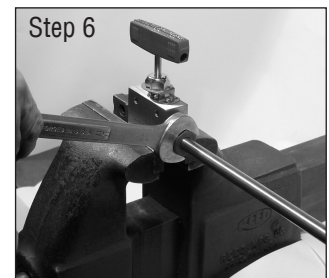
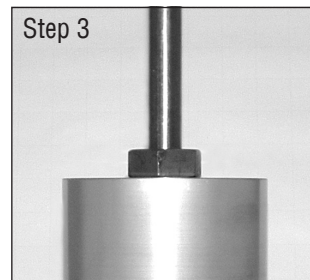
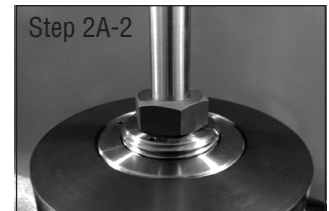
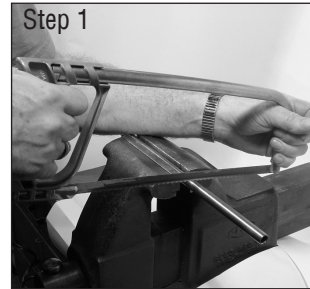

### Completed Connection

The hydraulically set sleeve has cut into the tubing as it moved forward into the tapered seat, upsetting material ahead of it and establishing a shoulder on the tubing to provide positive mechanical support for the tubing end-load. A properly set sleeve cannot be displaced back and forth along the tubing but may be rotated around the tubing.

### Reassembly

To reassemble a connection, insert tubing with sleeve and gland nut into valve or fitting. Install gland into valve/fitting.

### TIGHTEN GLAND NUT UNTIL SLEEVE BEGINS TO GRIP TUBING.

Note starting position of wrench.<sup>†</sup> Tighten gland nut 1/4 turn to complete the QSS connection.

\*\* Distance tubing protrudes into connection from face of fitting.

<sup>†</sup> A small blind hole on the face of the gland is provided for a starting position reference.

Parker Autoclave Engineers Medium Pressure tubing is required for these connection components.

When assembling tubing into fittings such as in rack systems, alignment of tubing is critical in connection make up. Do not force into alignment with connections as bending stress will effect the sealing capability of the connections.



# Tools, Installation, Operation and Maintenance - QS Hydraulic Set Tool

## QS Hydraulic Set Tool

The Parker Autoclave Engineers hydraulic sleeve set tool is designed for use with the QS Series glands, sleeves and Autoclave tubing. This tool is required to set the sleeve for the 9/16" and 3/4" sizes and suggested for the 1/4" and 3/8" sizes. It not only produces the required bite into the tubing, it is much easier than trying to set the sleeve the conventional method. The tool comes in a self contained portable, lockable case complete with hand or air pump, cap and dies for all sizes.

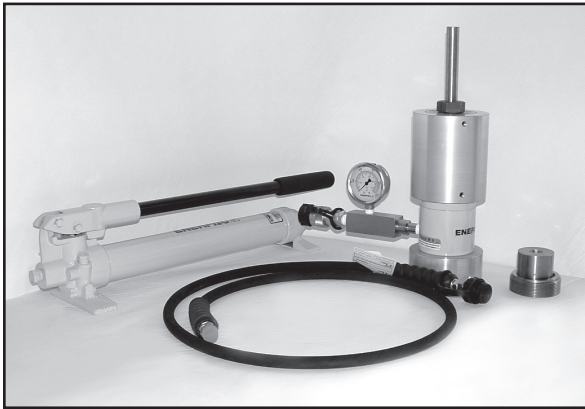

### Features

**Case Dimensions:** 28"W x 14.25"H x 13.75"D (711cm x 362cm x 292cm)

**Total Weight:** 69 lbs. (31 Kg)

**Hand Pump:** Single stage hydraulic (standard)

**Hydraulic Cylinder:** 10,000 psi, 2.5" 25 ton

**Base & Housing:** Aluminum anodized

**Die and Cap:** Precision hardened steel

**Gauge:** 15,000 psi (1034 bar)

**Air-operated hydraulic pump option** can be furnished in place of standard hand pump. (Add "-A" to order number). Operating pressure 0 to 10,000 psi (0 to 690 bar). Required air pressure, 30 psi (2.1 bar) minimum 120 psi (8.3 bar) maximum. Reservoir capacity: 24 cu. in. (393cm<sup>3</sup>). Air lubricator/air separator is recommended for air operated units.

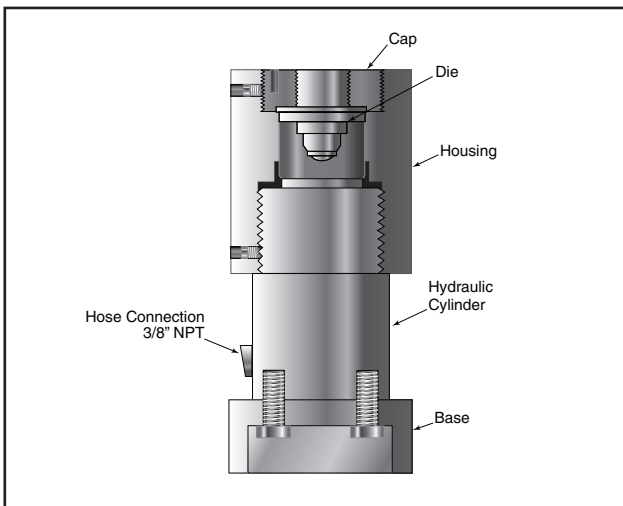

### Tooling Installation and Changing Sizes

To change tooling to another size only requires interchanging 2 parts.

1. Loosen the 5/16" set screw that locks the threaded cap from rotating.
2. Using a 5/32" hex key to rotate and remove the threaded steel cap from the aluminum housing.
3. Turn the tool assembly upside down to remove the die from inside the housing.
4. Install the die of the appropriate connection size you wish to use. The solid side of the die should be facing down towards the hydraulic cylinder.
5. Install the appropriate size cap to match the size of the die. Insert cap with the 5/32" hex up. Rotate with a 5/32" hex key until it bottoms out on the shoulder side of the housing.
6. Thread in the 5/16" set screw until it bottoms out on the cap threads. Tighten set screw to prevent movement during use.

### Ordering Information

**HST-912:** Complete tool kit with hand pump (shown in photo)

**HST-912TW:** Complete tool kit with torque wrench and adapters

**HST-912A:** Complete tool kit with air-operated pump (Air operated pump #P-1948)

**HST-912ATW:** Complete tool kit with torque wrench and adapters

**HST-S:** Complete table mounted system that includes everything in the HST-912ATW plus the required tooling for the 1" size connections. Not shown. Consult factory for replacement parts.

**Note:** 1" Torque wrench & adapter **NOT INCLUDED**

Description	Part #
Hydraulic Cylinder	90588
Gauge	90594
Adapter	90593
Base	101F-3407
Housing	101F-3408
Hydraulic Pump	P-1893
Hose	P-1894
3/4" Die	HSTD12
9/16" Die	HSTD9
3/4" Cap	HSTC12
9/16" Cap	HSTC9
Moly Paste	P-9766
1/4" Die	HSTD4
1/4" Cap	HSTC4
3/8" Die	HSTD6
3/8" Cap	HSTC6
(TW) Kits with torque and adapters	
10-150 ft-lbs (14-203 Nm) Torque Wrench	AE003325
50-250 ft-lbs (682-339 Nm) Torque Wrench	AE003326
5/8" wrench adapter	AE003321
3/4" wrench adapter	AE003322
1-3/16" wrench adapter	AE003324
1-1/2" wrench adapter	AE000170
1-3/4" wrench adapter	AE001067
100-600 ft-lbs (136-814) Torque Wrench	AE003327

## Anti-Vibration Collet Gland

### Assembly Procedure

Anti-vibration collet gland assembly replaces the standard gland nut.

1. Cone and thread tubing as defined on pages 5 and 6.
2. Slide collet assembly onto tube and install collar as described in the assembly and makeup of connections on page 6. One or two threads should be exposed between the collar and cone.
3. Lubricate male threads on glands (medium pressure anti-vibration assemblies supplied with a baked on dry film lubricant. Lubrication not required.)
4. Tighten gland or collet body to specified torque on page 13. The high pressure collet will grip the tube when the connection gland is tightened.
5. For the medium pressure collet gland assembly, hand tighten the collet gland in place and further tighten 1-1/4 turns with a wrench. When tightening the medium pressure anti-vibe collet nut, hold the collet body with a wrench to prevent the body from turning and over tightening. This will lock the collet against the tube. For subsequent retightening of the medium pressure anti-vibration collet gland, use 3/4 turns past finger tight.

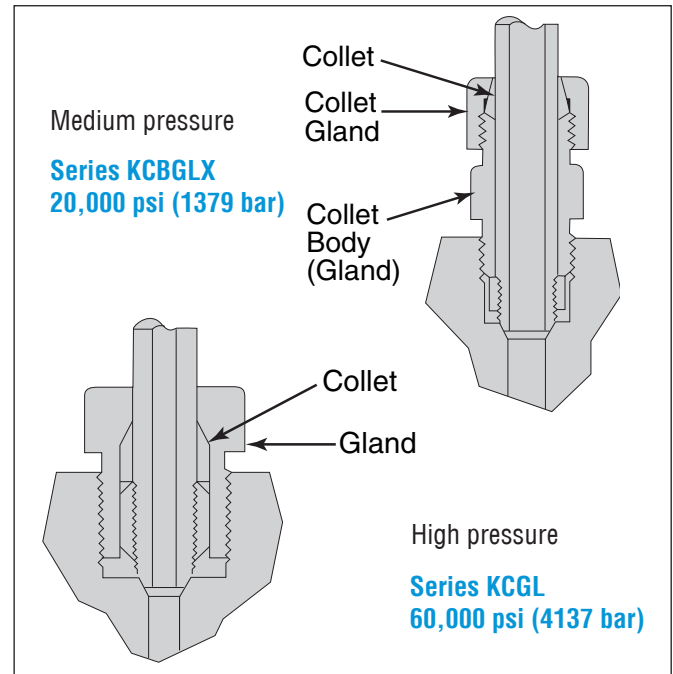

**Note: Always use a back-up wrench on collet body to prevent over tightening of collet body into connection.**

### Reseating tool - For female tubing connection cone seat

1. Clamp fitting in soft-jawed vise.
2. Thread gland nut into connection and tighten to 10 ft. lbs. (13.6 N.m).
3. Apply a medium weight high sulfur cutting oil generously through opening in nut. Cutting oil P-8784.
4. Insert reamer through guide bushing and press down firmly while rotating clockwise approximately two full turns, relieving pressure gradually toward end of second turn.
5. Remove reamer, guide nut and bushing and inspect cone seat.
6. Repeat steps 2,3,4 and 5, if necessary, until cone surface has been restored and finish is smooth.
7. Clean fitting thoroughly to remove all chips and residue.

	Connection Type	Reamer Complete	Guide Nut Assembly	Reamer	Handle
<p>Note: Connection type F250C100 and F375C100 use Reamer P-0271C150</p>	SF250CX	P-0270CX	A101A-2005	P-0270	202D-0596
	SF375CX	P-0271CX	A2020-7310	P-0271	202D-0596
	SF562CX	P-0272CX	A2030-7310	P-0896	202D-0596
	SF750CX	P-1726CX	A102A-3376	P-1726	201D-0595
	SF1000CX	P-1727CX	A102A-3375	P-1727	201D-0595
	SF1500CX	91409	-	91409-R	-
	F250C	P-0270C	A1010-0453	P-0270	202D-0596
	F312C150	P-0271C150	A2040-7310	P-0271	202D-0596
	F375C	P-0271C	A1020-0453	P-0271	202D-0596
	F562C / C40	P-0272C	A1030-0453	P-0272	202D-0596
	43F1000C	P-1727CX	A102A-3375	P-1727	201D-0595

## Coning and Threading Machine

### Benefits

- Coning and Threading of Parker Autoclave Engineers Medium and High Pressure Tubing.
- Separate heads for coning and threading are powered by a single motor and drive system.
- New design collet / support system allows for easier coning and threading of long tube lengths.
- New design tube depth gauge eliminates movement of tubing during the threading operation.

### Features

- 1/2-HP TEFC motor, capacitor start
- Pop-Open die prevents thread damage; no reversing necessary on threading
- Complete tooling available; order separately
- Supplied with oil pump and reservoir
- Optional oil reservoir heater for operation below 65° F (18.3°C)
- CE marked on 220 VAC units standard
- Unit mounted on stand with locking casters for ease of mobility and stability
- Guard option - see next page

### Ordering Procedure

(Tooling must be ordered separately see Table).

Model	Description
AEGCTM-2	115 VAC 60Hz
AEGCTM-2E-CE	220 VAC 50Hz
AEGCTM-2WOH	Standard units "with oil heater"
AEGCTM-2EWOH-CE	

### Approximate Dimensions:

56"h x 28"w x 20"d (142cm x 71cm x 51cm)

### Shipping Weight:

350 pounds (158.7 Kg)

### Cutting Oil:

Part Number: P-8699: 3-1/2 Gal (11.36 Liter) Reservoir Capacity

### Note 1:

A minimum of 5" (127mm) straight length of tubing is required to perform coning & threading operations.

### Video Aids Available:

Part Number: P-9930-D: Coning & Threading CD



Tube Size Inches (mm)	Collet Only (set)	Cutters Only (set)	Die Chasers (set)	Complete Set
1/4" x 0.109 (6.35 x 2.77)	CTM4C-2	CTM4BX	AEGCTM4D	AEGCTM4X-2
1/4" x 0.083 (6.35 x 2.10)	CTM4C-2	CTM4B	AEGCTM4D	AEGCTM4-2
5/16" x 0.062 (7.94 x 1.57)	CTM5C-2	CTM5B	AEGCTM5D	AEGCTM5-2
3/8" x 0.203 (9.53 x 5.16)	CTM6C-2	CTM6BX	AEGCTM6D	AEGCTM6X-2
3/8" x 0.125 (9.53 x 3.18)	CTM6C-2	CTM6B	AEGCTM6D	AEGCTM6-2
9/16" x 0.359 (14.29 x 9.12)	CTM9C-2	CTM9BXX	AEGCTM9D	AEGCTM9XX-2
9/16" x 0.312 (14.29 x 7.92)	CTM9C-2	CTM9BX	AEGCTM9D	AEGCTM9X-2
9/16" x 0.187 (14.29 x 4.78)	CTM9C-2	CTM9B	AEGCTM9D	AEGCTM9-2
9/16" x 0.250 (14.29 x 6.35)	CTM9C-2	CTM9B40	AEGCTM9D	AEGCTM940-2
3/4" x 0.516 (19.05 x 13.11)	CTM12C-2	CTM12BX	AEGCTM12D	AEGCTM12X-2
3/4" x 0.438 (19.05 x 11.13)	CTM12C-2	CTM12B	AEGCTM12D	AEGCTM12-2
1" x 0.688 (25.4 x 17.48)	CTM16C-2	CTM16BX	AEGCTM16D	AEGCTM16X-2
1" x 0.562 (25.4 x 14.27)	CTM16C-2	CTM16B	AEGCTM16D	AEGCTM16-2
1" x 0.438 (25.4 x 11.13)	CTM16C-2	CTM16BXX	AEGCTM16D	AEGCTM16XX-2

## Coning and Threading Machine

### Optional Oil/Chip Guard

A threading die oil/chip guard is available as an option on our AEGCTM machines.

The guard is a swing away Plexiglas design providing protection from splashing oil or thrown chips while allowing full access to the die head. The guard's sole purpose is the prevention of flying chips and oil not the prevention of operator access.

A guard option will also be available in a retrofit kit for our new existing machines (-2 models). The kit will contain all required items along with instructions.

To order a guard with a model, just add a G to the catalog number.

AEGCTM-2G

AEGCTM-2E-CEG

AEGCTM-2GK Retrofit kit catalog number

**Note:** Detailed operational instructions are supplied with the machine in two forms, printed and DVD. Refer to these instructions for tooling installation, machine adjustment, and maintenance instructions.

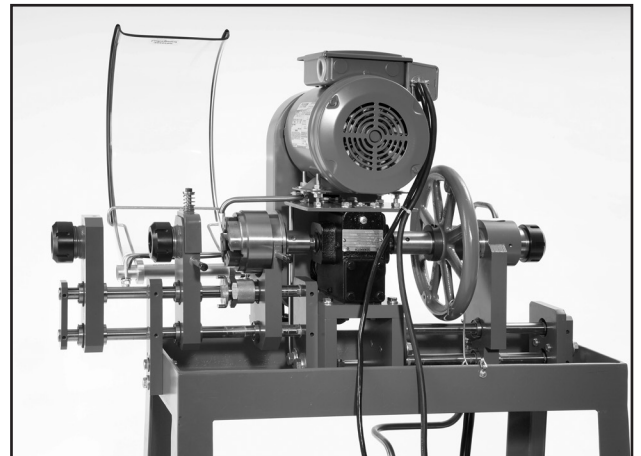
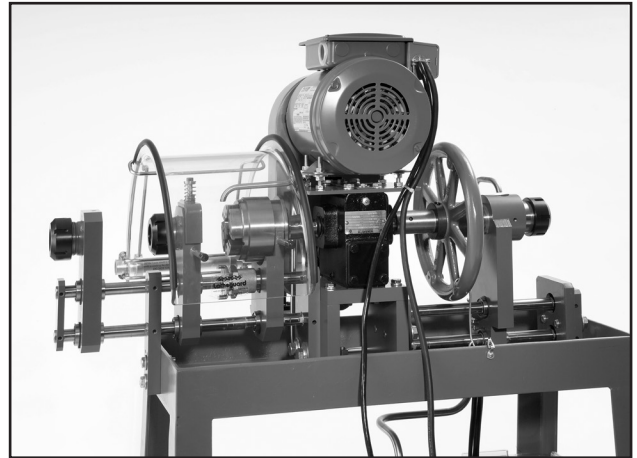

## Torque Values

### Autoclave Micrometer Adjustable Torque Wrenches

P-1680	20 to 150 ft. lbs. (27 to 203 Nm)
91020	75 to 250 ft. lbs. (102 to 339 Nm)
†91268	100 to 600 ft. lbs. (136 to 814 Nm)

(†Note: Only used with wrench adapter 91269)

Accurate tightening for all Parker Autoclave Engineers valve packing glands and tube nuts is essential. The wrench can be adjusted to the ranges shown above and is used with interchangeable wrench adapters for hex sizes from 1/2" through 1-7/8". Part numbers for wrench adapters are listed below. *Wrench adapters sold separately.*

### Standard Wrench Adapters

Wrench Adapter Number	Packing Gland or Tube Nut Hex Size (inches)
P-1681	1/2
P-1682	9/16
P-1683	5/8
P-9813	3/4
P-1685	13/16
P-1686	7/8
P-1687	15/16
P-9901	1
P-1688	1-1/16
P-1689	1-3/16
P-1690	1-3/8
P-6040	1-1/2
†91269	1-3/4
P-10076	1-7/8



### Connection Gland Torque

	Type of Connection	Gland Nut Hex Size (Inches)	Required Torque ft.-lbs. (N.m)	Required Torque Moly Coated
Medium Pressure	SF250CX	1/2	20 (27.1)	15 (20.4)
	SF375CX	5/8	30 (40.6)	20 (27.1)
	SF562CX10	15/16	55 (74.5)	40 (54.4)
	SF562CX20	15/16	55 (74.5)	40 (54.4)
	SF750CX10	1-13/16	75 (101.6)	55 (74.6)
	SF750CX20	1-13/16	90 (122.0)	70 (95.0)
	SF1000CX10	1-3/8	135 (186.5)	100 (135.6)
	SF1000CX20	1-3/8	135 (186.5)	100 (135.6)
High Pressure	SF1500CX	1-7/8	200 (271.2)	160 (217.0)
	F250C	5/8	25 (33.9)	—
	F250C100	5/8	50 (67.8)	—
	F312C150	3/4	70 (94.9)	—
	F375C	13/16	50 (68)	—
	F375C100	5/8	105 (142.8)	—
	F562C	1-3/16	75 (101.6)	—
	F562C40	1-3/16	60 (81.4)	—
	SF1000C30	1-3/8	150 (203.3)	—
	F1000C43	1-3/8	180 (244.0)	—

All dimensions for reference only and subject to change.

### Valve Stem Maximum Running and Seating Torques\* (Typical Values)

Valve Series	Tube Size (Inches)	Running Torque in.-lbs. (N.m)	Seating Torque in.-lbs. (N.m)	Pressure psi (bar)
10V	1/8	25 (2.80)	35 (3.90)	15,000 (1034)
	1/4	40 (4.50)	50 (5.60)	15,000 (1034)
	3/8	40 (4.50)	50 (5.60)	15,000 (1034)
	1/2	60 (6.80)	80 (9.10)	10,000 (690)
SW	1/4	25 (2.80)	35 (3.90)	15,000 (1034)
	3/8	40 (4.50)	50 (5.60)	15,000 (1034)
	1/2	70 (7.90)	90 (10.20)	10,000 (690)
15SM24	1-1/2	1100 (124.2)	1560 (176)	15,000 (1034)
15SM	9/16	60 (6.80)	80 (9.10)	15,000 (1034)
	3/4	210(23.80)	240 (27.20)	15,000 (1034)
	1	180 (20.40)	540 (61.10)	15,000 (1034)
20SM	1/4	40 (4.50)	55 (6.20)	20,000 (1379)
	3/8	40 (4.50)	55 (6.20)	20,000 (1379)
	9/16	60 (6.80)	90 (10.20)	20,000 (1379)
	3/4	300 (33.90)	360 (40.70)	20,000 (1379)
	1	360 (40.70)	600 (67.90)	20,000 (1379)
30SC	1	360 (40.70)	650 (73.4)	30,000 (2068)
43SC	1	720 (82.0)	840 (95.0)	43,000 (2965)
40SC	9/16	360 (40.70)	445 (50.3)	40,000 (2758)
30VM	1/4	40 (4.50)	55 (6.20)	30,000 (2068)
	3/8	45 (5.00)	55 (6.20)	30,000 (2068)
	9/16	50 (5.60)	55 (6.20)	30,000 (2068)
40VM	9/16	40 (4.50)	55 (6.20)	40,000 (2758)
60VM	1/4	65 (7.30)	70 (7.90)	60,000 (4137)
	3/8	65 (7.30)	70 (7.90)	60,000 (4137)
	9/16	65 (7.30)	70 (7.90)	60,000 (4137)
100VM	1/4, 5/16, 3/8	100 (11.3)	120 (13.6)	100,000 (6895)
	9/16	460 (52.0)	520 (59.0)	100,000 (6895)

\* These are not specifications.

Note: All valve stem torques are based on standard PTFE packing. For valves with option "TG" (PTFE Glass) or "GY" (graphite - yarn packing), the following equations should be used to estimate torques.

Running Torque "GY" = 2 x running torque  
 Seating Torque "GY" = 2 x running torque + seating torque - running torque  
 Running Torque "TG" = 1.1 x running torque  
 Seating Torque "TG" = 1.1 x running torque + seating torque - running torque

### Parker AE Flat Top/Bottom Adapters

	Size inches	Maximum Working Pressure psi (bar)	Connection	Required Torque ft. - lbs. (N.m)
Flat Top Gasket	9/16	10,000 (690)	F562FT	60 (81.3)
	7/16	10,000 (690)	F437FB	25 (33.9)
Flat Bottom Gasket	9/16	10,000 (690)	F562FB	40 (54.2)
	3/4	5,000 (345)	F750FB	60 (81.3)

## Torque Values

### Parker AE Packing Glands

Valve Series	Outside Diameter Size (inches)	Packing Gland Hex (Inches)	Required Torque <sup>1</sup> ft.-lbs. (N.m)
10V	1/8	1/2	12 (16.3)
	1/4	13/16	40 (54.2)
	3/8	13/16	40 (54.2)
	1/2	13/16	30 (40.7)
SW	1/4	5/8	30 (40.7)
	3/8	5/8	4 (54.2)
	1/2	13/16	50 (67.8)
15SM24	1-1/2	1-5/16	325 (440.6)
15P 10P 15SM 20SM 15QS	1/4	5/8	40 (54.2)
	3/8	5/8	40 (54.2)
	9/16	13/16	80 (108.5)
	3/4	13/16	Note: <sup>2</sup>
	1	1-3/8	20 (27.1)
30SC/43SC	1	1-3/8	230 (311.8)
40SC	9/16	15/16	140 (190.0)
30VM	1/4	13/16	60 (81.3)
	3/8	13/16	60 (81.3)
	9/16	13/16	60 (81.3)

### Parker AE Packing Glands

Valve Series	Outside Diameter Size (Inches)	Packing Gland Hex (Inches)	Required Torque <sup>1</sup> ft.-lbs. (N.m)
40VM	9/16	13/16	40 (54.2)
60VM	1/4	13/16	60 (81.3)
	3/8	13/16	60 (81.3)
	9/16	13/16	60 (81.3)
100VM	1/4, 5/16, 3/8	15/16	60 (81.3)
150V	5/16	1-3/8	150 (203.3)
15Y	3/4	15/16	130 (176.3)
	1	1-1/16	150 (203.3)
50Y	9/16	15/16	85 (115.2)
10VRMM	9/16	9/16	20 (27.1)
30VRMM	3/4	13/16	50 (67.8)
60VRMM	1/4	13/16	50 (67.8)
	3/8	13/16	50 (67.8)

1 - Torque may vary  $\pm 10\%$ . Torque values apply to standard PTFE packing. For graphite yarn packing, add 25% to the above values.

2 - 3/4 turn past finger tight with hex wrench.

### Special Material Connection Torque Table Pressure psi (bar) vs. Torque ft.-lbs. (N.m)

Note: Use the recommended torque value for special material valves and fittings based on the maximum allowable working pressure of the valve or fitting

Connection	Pressure psi (bar)										
	Minumum	2,500 (172)	5,000 (345)	10,000 (690)	15,000 (1034)	20,000 (1379)	25,000 (1724)	30,000 (2068)	40,000 (2758)	50,000 (3447)	60,000 (4137)
SF250CX	10 (13.6)	10 (13.6)	10 (13.6)	10 (13.6)	15 (20.3)	20 (27.1)	—	—	—	—	—
SF375CX	10 (13.6)	10 (13.6)	10 (13.6)	15 (20.3)	25 (33.9)	30 (40.7)	—	—	—	—	—
SF562CX10	20 (27.1)	20 (27.1)	30 (40.7)	45 (61.0)	55 (74.6)	—	—	—	—	—	—
SF562CX20	15 (20.3)	15 (20.3)	15 (20.3)	30 (40.7)	40 (54.2)	55 (74.6)	—	—	—	—	—
SF750CX10	25 (33.9)	25 (33.9)	40 (54.2)	60 (81.3)	75 (101.7)	—	—	—	—	—	—
SF750CX20	20 (27.1)	20 (27.1)	25 (33.9)	45 (61.0)	70 (94.9)	90 (122.0)	—	—	—	—	—
SF1000CX10	40 (54.2)	40 (54.2)	65 (88.1)	115 (156.0)	135 (183.0)	—	—	—	—	—	—
SF1000CX20	35 (47.5)	35 (47.5)	50 (67.8)	100 (135.6)	115 (156.0)	135 (183.0)	—	—	—	—	—
SF1500CX	110 (149.1)	110 (149.1)	110 (149.1)	160 (217.0)	200 (271.2)	—	—	—	—	—	—
F1000C43	30 (40.7)	30 (40.7)	50 (67.8)	65 (88.1)	75 (101.7)	100 (135.6)	125 (169.5)	150 (203.3)	180 (244.0)	—	—
F250C	10 (13.6)	10 (13.6)	10 (13.6)	10 (13.6)	10 (13.6)	10 (13.6)	15 (20.3)	15 (20.3)	20 (27.1)	25 (33.9)	25 (33.9)
F375C	10 (13.6)	10 (13.6)	10 (13.6)	10 (13.6)	15 (20.3)	20 (27.1)	25 (33.9)	25 (33.9)	35 (47.5)	45 (61.0)	50 (67.8)
F562C	15 (20.3)	15 (20.3)	15 (20.3)	15 (20.3)	20 (27.1)	25 (33.9)	35 (47.5)	40 (54.2)	50 (67.86)	65 (88.1)	75 (101.7)
F562C40	15 (20.3)	15 (20.3)	15 (20.3)	15 (20.3)	25 (33.9)	30 (40.7)	40 (54.2)	45 (61.0)	60 (81.3)	—	—
F562C40-312	25 (34.0)	25 (34.0)	25 (34.0)	25 (34.0)	35 (47.5)	45 (61.0)	55 (74.6)	65 (88.1)	85 (115.2)	—	—

## Tube Connection Dimensions

### Parker Autoclave SpeedBite SW\*

Tube Outside Diameter (inches)	Connection Type	Dimensions inches (mm)						
		A	B	C	D	E	F	G
1/4	SW250	29/64 (11.5)	1/2 -20	0.34 (8.6)	0.44 (11.1)	0.69 (17.5)	0.35 (8.9)	"F" 0.257 (6.5)
3/8	SW375	37/64 (14.7)	5/8 -18	0.38 (9.7)	0.47 (11.9)	0.75 (19.1)	0.48 (12.1)	"W" 0.386 (9.8)
1/2	SW500	3/4 (19.1)	13/16 -16	0.38 (9.7)	0.50 (12.7)	0.81 (20.6)	0.60 (15.21)	0.516 (13.11)

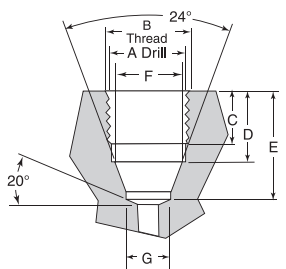

### Parker Autoclave SpeedBite W\* (reference only)

Tube Outside Diameter (inches)	Connection Type	Dimensions inches (mm)						
		A	B	C	D	E	F	G
1/16 1/8	W062 W125	"Q" 0.332 (8.4)	3/8 -24	0.22 (5.6)	0.31 (7.9)	0.47 (11.9)	0.19 (4.8)	#30 0.129 (3.3)
1/4	W250	11/16 (17.4)	3/4 -16	0.38 (9.7)	0.44 (11.1)	0.69 (17.7)	0.35 (8.9)	"F" 0.257 (6.5)
3/8	W375	11/16 (17.4)	3/4 -16	0.38 (9.7)	0.44 (11.1)	0.69 (17.7)	0.48 (12.1)	"W" 0.386 (9.8)

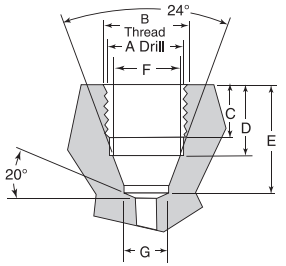

### Parker Autoclave QSS

Tube Outside Diameter (inches)	Connection Type	Dimensions inches (mm)							
		A	B	C	D	E	F	G	H
1/4	QSF250	29/64 (11.5)	1/2 -20	0.34 (8.6)	0.44 (11.1)	0.69 (17.5)	0.34 (8.6)	"F" 0.257 (6.5)	.015 (3.81)
3/8	QSF375	37/64 (14.7)	5/8 -18	0.38 (9.7)	0.47 (11.9)	0.75 (19.1)	0.48 (12.1)	.038" (9.7)	.025 (9.7)
9/16	QSF562	7/8 (22.2)	15/16 -16	0.57 (14.5)	0.704 (17.9)	1.25 (31.8)	0.712 (18.1)	0.57 (14.5)	.359 (9.12)
3/4	QSF750	1-3/16 (30.15)	1-1/4 -18	0.83 (21.08)	1.00 (25.40)	1.56 (39.62)	0.95 (24.13)	0.76 (19.30)	.576 (14.6)
1	QSF1000	1-9/16 (39.70)	1-5/8 -16	.75 (19.1)	.88 (22.2)	1.56 (39.62)	1.24 (31.5)	1.02 (26.0)	.688 (17.5)

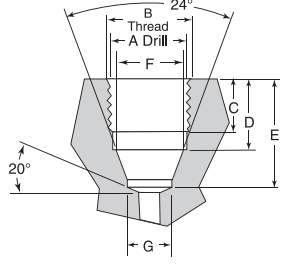

Note: All dimensions are shown for reference only and should not be considered as actual machining dimensions.

\*For port diameter please see orifice sizes for specific valves and fittings.

All threads are manufactured to a class 2A or 2B fit.

For prompt service, Parker Autoclave Engineers stocks select products. Consult factory. All general terms and conditions of sale, including limitations of our liability, apply to all products and service sold.

## Tube Connection Dimensions

### Parker Autoclave Medium Pressure SF\*\*

Tube Outside (inches)	Connection Type	Dimensions inches (mm)					
		A	B	C	D	F	H
1/4	SF250CX	25/64 (9.9)	7/16 -20	0.28 (7.1)	0.50 (12.7)	0.19 (4.8)	0.109 (2.8)
3/8	SF375CX	33/64 (13.1)	9/16 -18	0.38 (9.7)	0.63 (16.0)	0.31 (7.9)	0.203 (5.2)
9/16	*SF562CX10 SF562CX20	3/4 (19.1)	13/16 -16	0.44 (11.1)	0.75 (19.1)	0.50 (12.7)	0.359 (9.1) 0.312 (7.9)
3/4	*SF750CX10 SF750CX20	61/64 (24.2)	3/4 -14 See Note 1	0.50 (12.7)	0.94 (23.9)	0.63 (16.0)	0.516 (13.1) 0.438 (11.1)
1	*SF1000CX10 SF1000CX20	1-19/64 (32.9)	1-3/8 -12	0.81 (20.6)	1.31 (33.3)	0.88 (22.4)	0.688 (17.5) 0.562 (14.3)
1-1/2	SF1500CX	1.790 (45.47)	1-7/8 -12	1.00 (25.4)	1.59 (40.38)	1.38 (35.05)	.937 (23.80)

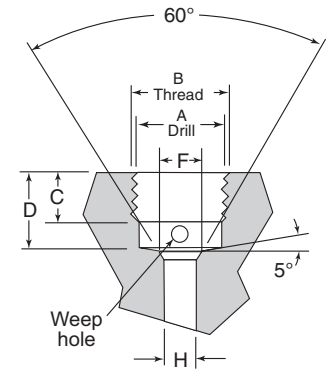

Note 1 = NPS Male Tap

\* Connection used in fittings rated for 20,000 psi (1379 bar).  
Note 1 - 3/4-14 is a straight pipe thread.

### Parker Autoclave High Pressure F\*\*

Tube Outside (inches)	Connection Type	Dimensions inches (mm)					
		A	B	C	D	F	H
1/4	F250C	33/64 (13.1)	9/16 -18	0.38 (9.7)	0.44 (11.1)	0.17 (4.3)	0.094 (2.4)
3/8	F375C	11/16 (17.4)	3/4 -16	0.53 (13.5)	0.62 (15.7)	0.26 (6.6)	0.125 (3.2)
5/16	F312C150	37/64 (14.7)	5/8 -18	0.63 (16.0)	1.06 (26.9)	0.25 (6.4)	0.094 (2.4)
9/16	F562C	1-3/64 (26.6)	1-1/8 -12	0.63 (16.0)	0.75 (19.1)	0.38 (9.7)	0.188 (4.8)
9/16	F562C40	1-3/64 (26.6)	1-1/8 -12	0.63 (16.0)	0.75 (19.1)	0.38 (9.7)	0.250 (6.4)
9/16	F562C40-312	1-3/64 (26.6)	1-1/8 -12	0.63 (16.0)	0.75 (19.1)	0.38 (9.7)	0.312 (7.9)
1	F1000C43	1-19/64 (32.9)	1-3/8 -12	0.81 (20.6)	1.31 (33.3)	0.88 (22.4)	0.438 (11.1)

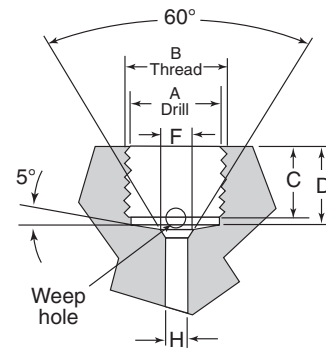

### Parker Autoclave Ultra High Pressure F\*\*

Tube Outside (inches)	Connection Type	Dimensions inches (mm)					
		A	B	C	D	F	H
1/4	F250C100	37/64 (14.7)	5/8 -18	0.63 (16.0)	1.06 (26.9)	0.25 (6.4)	0.094 (2.4)
3/8	F375C100	37/64 (14.7)	5/8 -18	0.63 (16.0)	1.06 (26.9)	0.25 (6.4)	0.125 (3.2)
9/16	F562C100	1-3/64 (26.6)	1-1/8 -12	0.63 (16.0)	0.75 (19.1)	0.38 (9.7)	0.188 (4.8)

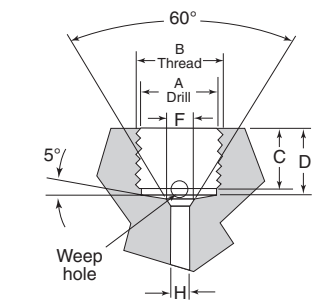

Note: All dimensions are shown for reference only and should not be considered as actual machining dimensions.

\*For port diameter please see orifice sizes for specific valves and fittings.

\*\*For male tubing end preparation, please see pages 5 and 6.  
All threads are manufactured to a class 2A or 2B fit.

For prompt service, Parker Autoclave Engineers stocks select products. Consult factory. All general terms and conditions of sale, including limitations of our liability, apply to all products and service sold.



## Hydraulic Tube Bender

### For Single Pass Bending of High Pressure Tubing

The Parker Autoclave Engineers hydraulic tube bender is designed to bend heavy wall tubing and provide fast, accurate and reliable bending with only one setup. The tube bender is complete with pump, cylinder, frame and bending shoes which are self contained in a portable, lockable case. (Order number: HTB)

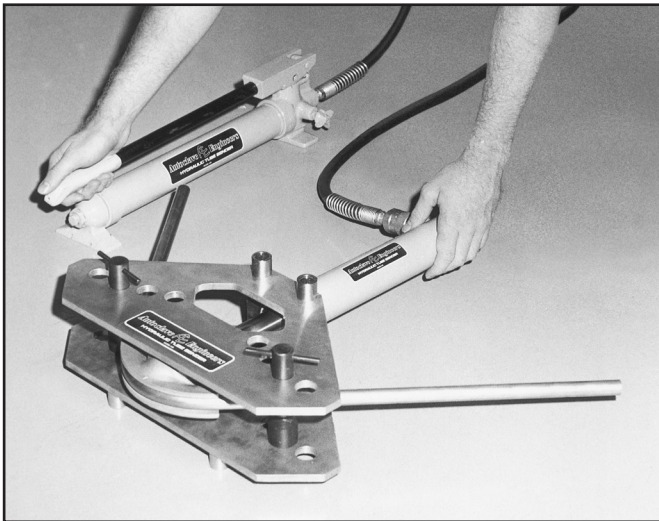

### Features

**Dimensions:** 27.5"W x 14.0"H x 14.0"D (69.9cm x 35.6cm x 35.6cm).

**Weight:** 55 lbs. (29.9 Kg)

**Single-stage hydraulic hand pump (standard)**

**Ram retractor valve** relieves system pressure after bending. The spring loaded ram retracts for easy removal of tubing after bending is completed.

**Quick release pivot pins** lock and unlock easily for tube removal.

**One-piece shoe locking pin** locks bending shoe securely but allows for quick release to interchange shoes.

**Rugged bending frame** is lightweight, aircraft quality, aluminum alloy.

**Precision one-piece bending shoes** are permanent mold, heat-treated, aircraft quality, aluminum alloy.

**Air-operated hydraulic pump option** can be furnished in place of standard hand pump. (Add "-A" to order number) Operating pressure 0 to 10,000 psi (0 to 690 bar). Required air pressure 30 psi (2.1 bar) minimum 120 psi (8.3 bar) maximum. Reservoir capacity 24 cu. in. (393cm<sup>3</sup>). Available with optional hydraulic pressure gauge and gauge adapter. A lubricator/air separator is recommended for air operated units.

### Minimum Bend (Mandrel) Radius

Shoe* Catalog Number	Tube Size Inches (mm)		†† Rated Pressure (bar)	†† Minimum Bend Inside Radius Inches (mm)	Minimum Length Required 90° Bend Inches (cm)
	Outside Diameter	Inside Diameter			
201A-6016	9/16 (14.29)	0.359 (9.12)	15,000 (1034)	2.62 (66.5)	14 (35.6)
201A-6018	3/4 (19.05)	0.516 (13.11)	15,000 (1034)	3.50 (88.9)	16 (40.6)
201A-6020	1 (25.4)	0.688 (17.48)	15,000 (1034)	4.62 (117.3)	22 (55.8)
201A-6014†	1/4 (6.35)	0.109 (2.77)	20,000 (1379)	1.25† (31.8)	8 (20.3)
201A-6014	3/8 (9.53)	0.203 (5.16)	20,000 (1379)	1.75 (44.5)	8 (20.3)
201A-6016	9/16 (14.29)	0.312 (7.92)	20,000 (1379)	2.62 (66.5)	14 (35.6)
201A-6018	3/4 (19.05)	0.438 (11.13)	20,000 (1379)	3.50 (88.9)	16 (40.6)
201A-6020	1 (25.4)	0.562 (14.27)	20,000 (1379)	4.62 (117.3)	22 (55.8)
201A-6020	1 (25.4)	0.438 (11.13)	43,000 (2965)	4.62 (117.3)	22 (55.8)
201A-6014†	1/4 (6.35)	0.083 (2.10)	60,000 (4137)	1.25† (31.8)	8 (20.3)
201A-6014	3/8 (9.53)	0.125 (3.18)	60,000 (4137)	1.75 (44.5)	8 (20.3)
201A-6016	9/16 (14.29)	0.250 (6.35)	40,000 (2758)	2.62 (66.5)	14 (35.6)
201A-6016	9/16 (14.29)	0.188 (4.78)	60,000 (4137)	2.62 (66.5)	14 (35.6)
N/A**	5/16 (7.94)	0.062 (1.57)	150,000 (10342)	6.00 (152.4)	8 (20.3)

Annealed Parker Autoclave Engineers pressure tubing may also be bent on HTB tube bender using bending shoe sizes specified above.

\* HTB bending shoes are constructed of heat-treated aluminum alloy and designed specifically for use with Parker Autoclave Engineers' heavy wall stainless tubing. They are not intended for bending such components as commercial pipe. Because of diameter differences, such misuse could fracture the bending shoe.

\*\* Information on bending 150,000 psi (10342 bar) tubing is included here for reference only. This tubing should not be bent on HTB hydraulic tube bender because of the 6" required minimum radius.

† Value shown is minimum bend radius of the tubing; bending shoe furnished (201A-6014) will bend tubing to 1.75" (44.5).

†† Pressure rating of the bent tube will be reduced. Consult the Technical Application section for pressure rating at various bend radii.

All dimensions for reference only and subject to change.

## Lubrication Guide

### General Information

For reliable operation and long life of hand valves, air valves, relief valves, check valves and safety heads, Parker Autoclave Engineers strongly recommends proper lubrication of all components that are subject to friction during assembly and / or operation. This is especially important where metal to metal contact occurs such as on connection gland threads, packing gland threads and stem threads. Without proper lubrication, the high loads imposed on these threads may cause the parts to weld (or gall) together from the high metal to metal contact forces and friction heat. Lubrication is also essential for the effective sealing and long life of o-rings, especially those that are used in dynamic sealing applications. The performance of metal to metal seals will be improved with lubrication but, they do not absolutely require it.

Lubricant selection is strongly dependent on the application of the given component. Process fluids, fluid temperature, ambient environment temperature, materials and other factors are important in selecting a lubricant. This manual gives some basic guidelines in the proper selection and application of lubricants. The end user must ultimately determine the suitability of a lubricant based on process requirements.

Note: Parker Autoclave Engineers assumes no liability in selecting lubricant for customer applications.

### Lubrication Sites

**1. Speedbite, Slimline and High Pressure Connections in all valves and fittings** - Prior to assembly, the connection gland should be lubricated on the threads and on the area that is in contact with the sleeve or collar. Parker AE provides as standard a dry molybdenum disulfide lubricant on Speedbite glands unless specified otherwise. If process tolerable, a small amount of any lubricant (or process fluid) on the end of the tube cone or connection sleeve will help to maximize the metal-to-metal sealing process. This inherently provides for better sealing of gases.

**2. Hand Valves** - Ideally, the non-rotating stem should be lubricated along the shank that fits into the threaded stem sleeve as well as on the surfaces that are in contact with the stem washers. The threaded stem sleeve should be lubricated on the stem threads and at the ends (see Figure 1). The packing gland should be lubricated on the external threads and on the end that is in contact with the packing washer. For valves with replaceable seats, the external threads on the seat retainer and the portion of the seat retainer in contact with the seat should be lubricated.

**3. Air Valves** - The packing gland and seat retainer (if the valve has a replaceable seat) should be lubricated in the same manner as the hand valve. Threads should also be lubricated on all of the yoke screws (for yoke style valves) and on the retainer insert (on other air operated valves).

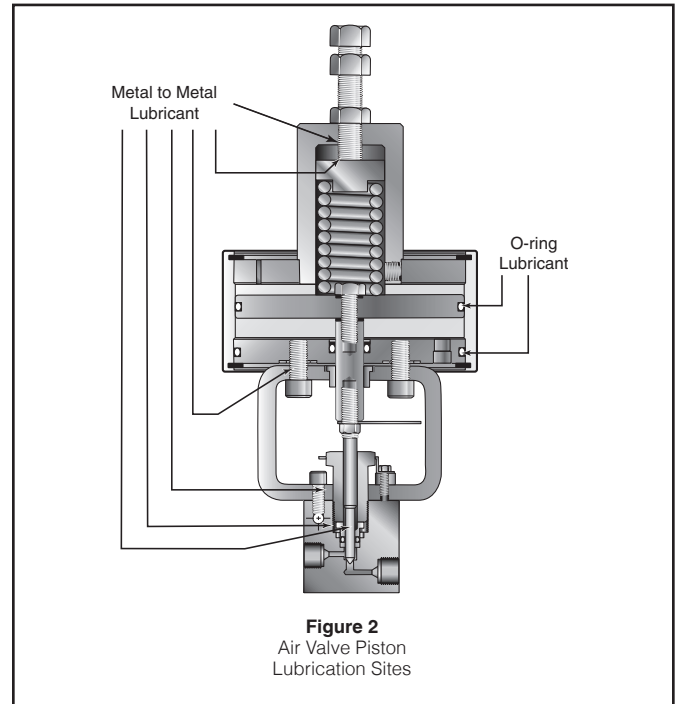

**Figure 2**  
Air Valve Piston  
Lubrication Sites

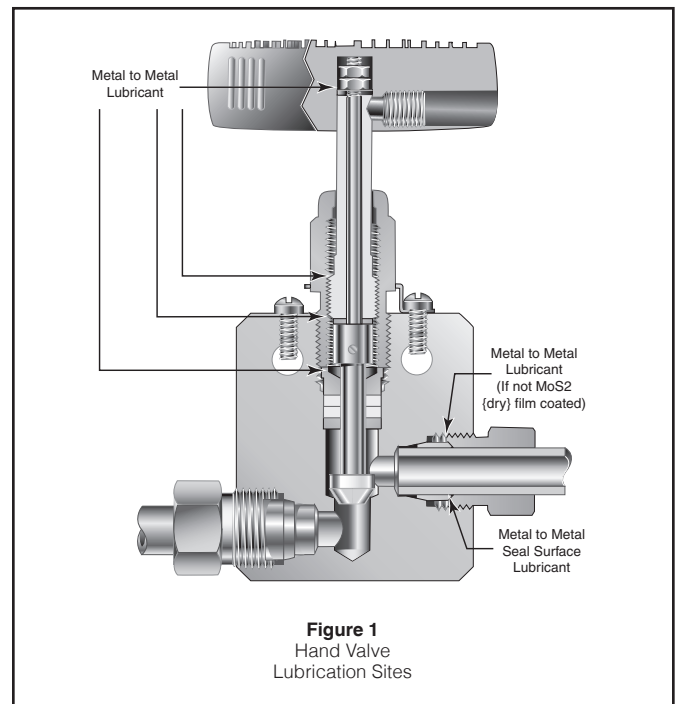

**Figure 1**  
Hand Valve  
Lubrication Sites

For piston type air operators, o-ring lubricant should be applied to the inside of the operator housing, on the center rod and on all the o-rings, on the pistons and divider plates. On air-to-open diaphragm operators, the o-ring on the stem should be lubricated. The threads and end of the spring adjustment screw should be lubricated on all air-to-open valves. Refer to Figure 2 and 3 for lubrication sites on piston and diaphragm style operators.

**4. Check Valves** - The gland nut should be lubricated on the external threads and at the end where it contacts the cover. The cover should be lubricated at the sealing surface where it contacts the body. For o-ring check valves, a small amount of o-ring lubricant on the o-ring will help swell the elastomer and aid sealing. Refer to Figure 4 for lubrication sites on check valves.

**5. Relief Valves** - Threads should be lubricated on the cap, spring cylinder, adjustment bolt and on the seat gland. Refer to Figure 5 for lubrication sites on the relief valve.

**6. Safety Heads** - The threads and end of the hold down nut should be lubricated. Refer to figure 6 for lubrication sites on the safety head.

For any part not covered in the above statements, the general rule is that parts that will move against each other during assembly or operation should be lubricated at the points/areas of contact.

## Recommended Lubricants

Note: This information is provided for reference only. The manufacture of the lubricant should be contacted for specific information based on your application. Refer to the material safety data sheets for information on safe usage and storage methods for these lubricants.

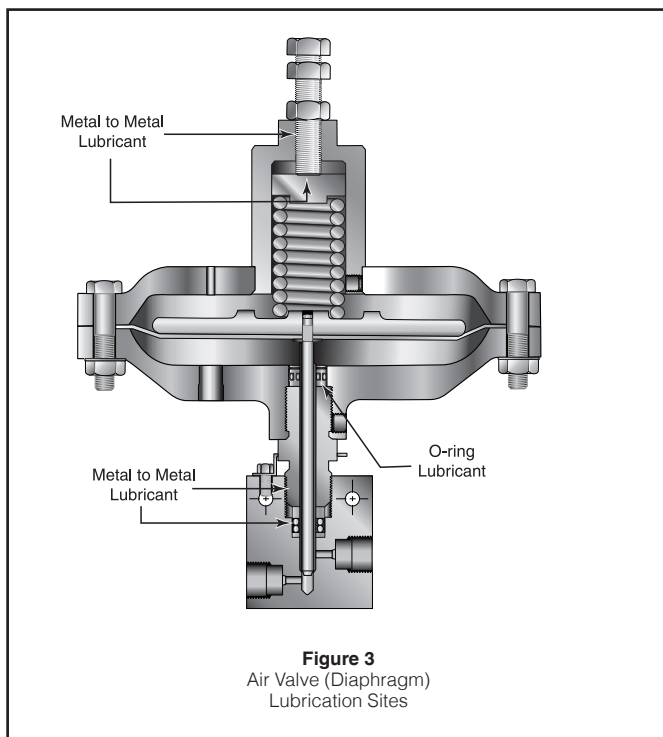

**1. Jet Lube SS-30<sup>1</sup>** - This lubricant consists of pure copper flakes that are homogenized into a non-melting, nonvolatile viscous carrier. It is fortified with anti-oxidants, rust and corrosion inhibitors. Jet Lube SS-30 is the standard lubricant for Parker Autoclave VFT components with sliding metal to metal contact surfaces. The surfaces are copper coated and prevents seizure, galling and heat freeze. SS-30 comes in the form of a thick oil that can be easily brushed on the surfaces to be lubricated. The absolute service temperature range is from 0 to 1800°F (-17.8 to 982°C). Jet Lube SS-30 is not recommended for extreme low temperature applications or processes that will not tolerate the presence of copper.

**2. Jet Lube MP-50 Moly Paste<sup>1</sup>** - This is a thick paste that contains molybdenum disulfide (MoS). This lubricant is suitable for preventing seizure and galling of parts at absolute temperatures of -300 to 750°F (-184 to 399°C). It is recommended for metal to metal components that are exposed to temperatures of less than 0°F. Other lubricants may solidify under these conditions and prevent the effective operation of dynamic components.

**3. DuPont Krytox 240AC<sup>2</sup>** - Krytox is a non-flammable fluorinated grease used for metal to metal lubrication in valves that are cleaned and designated for oxygen service. It comes in the form of a white grease and has a recommended absolute service temperature range of -15 to 500°F (-26.1 to 260°C).

**4. Molycoat 55M4 (Dow Corning)** - This grease is used for static lubrication between rubber and metal parts in ball valves and o-ring check valves. It is a silicone based lubricant and meets Military Specifications MIL-G-4343. It is not recommended for use on silicone rubber o-rings and seals. It has a recommended absolute service temperature range of -85 to 350°F (-65 to 177°C).

**5. Neolube DAG 156<sup>3</sup>** - This is a dry film lubricant for valves used in Navy Nuclear service. It consists of graphite particles in a thermoplastic resin and isopropanol and meets Military Specification MIL-L-24131B. The dry film form allows tight control of impurities that are required for these applications. It has an absolute service temperature of -100 to 400°F.

**6. LubriPlate-NSF H-1 Registered, Extremely Tacky, Food Grade Greases** - This grease is used for dynamic lubrication between rubber and metal parts in pneumatic systems such as piston style air operators. A tacky, adhesive, highly water resistant grease for medium to slow dynamic speeds. It has a recommended absolute service temperature range of -0 to 350°F (-17.8 to 177°C).

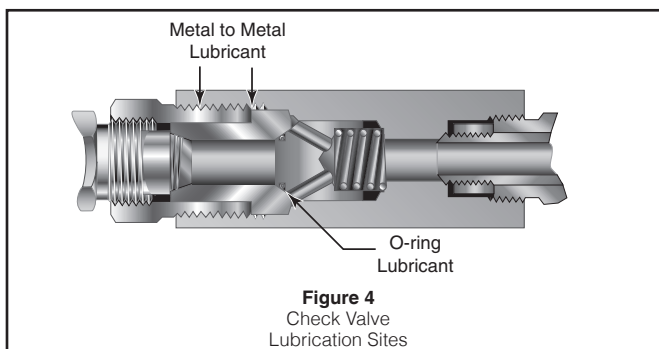

## Services

For service, contact the Parker Autoclave Engineers' Representative in your area, or FAX Parker Autoclave Engineers' Customer Support Services at 1-814-860-5703.

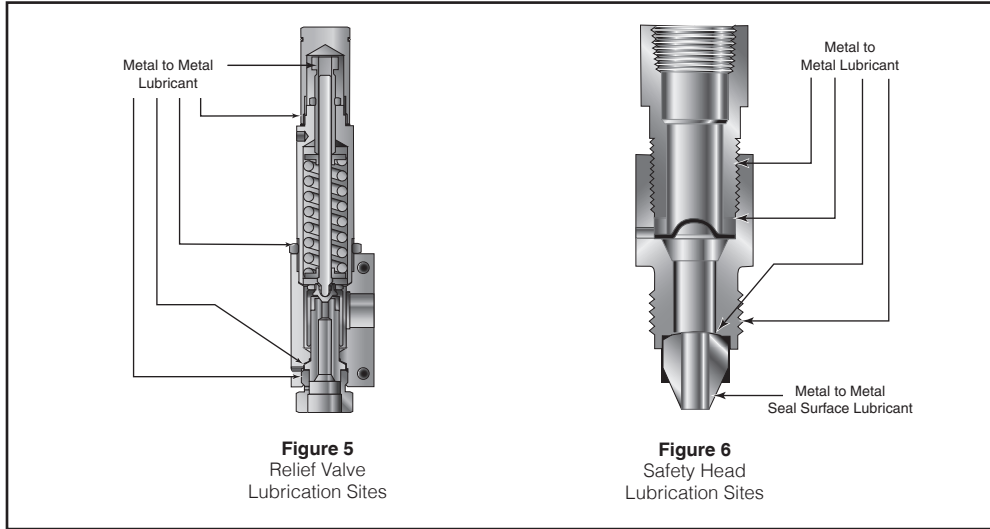

## Lubrication Selection Chart

Lubrication	Part No.	Application	Absolute Service Temperature Range
Jet-Lube SS-30	P-3580	Metal to Metal, Standard Application	0°F to 1800°F (-18°C to 982°C)
Jet-Lube Moly Paste MP-50	P-9766	Metal to Metal, Low Temperature Application	-300°F to 750°F (-185°C to 398°C)
Krytox 240 AC	53893	Metal to Metal, Oxygen Clean Components	-15°F to 500°F (-26°C to 260°C)
MolyKote 55 Dow Corning	90085	Check Valve Ball and Poppet Lubricant	-85°F to 350°F (-65°C to 177°C)
Neolube DAG 156		Metal to Metal, Nuclear Service	-100°F to 400°F (-73°C to 204°C)
LubriPlate Pure Tac		Dynamic O-ring Seals-Air Operator Housing	0°F to 350°F (-18°C to 177°C)

Notes: Specific applications may require other service temperature ranges.

<sup>1</sup>SS-30 and MP-50 Moly Paste are registered trademarks of Jet Lube Inc.

<sup>2</sup>Krytox is a registered trademark of E.I.duPont de Nemours & Co., Inc.

<sup>3</sup>DAG is a registered trademark of Acheson Industries, Inc.

<sup>4</sup>Molycoat and Dow Corning are registered trademarks of Dow Corning Corp

### WARNING

**FAILURE, IMPROPER SELECTION OR IMPROPER USE OF THE PRODUCTS AND/OR SYSTEMS DESCRIBED HEREIN OR RELATED ITEMS CAN CAUSE DEATH, PERSONAL INJURY AND PROPERTY DAMAGE.**

This document and other information from Parker Hannifin Corporation, its subsidiaries and authorized distributors provide product and/or system options for further investigation by users having technical expertise. It is important that you analyze all aspects of your application and review the information concerning the product or system in the current product catalog. Due to the variety of operating conditions and applications for these products or systems, the user, through its own analysis and testing, is solely responsible for making the final selection of the products and systems and assuring that all performance, safety and warning requirements of the application are met. The products described herein, including without limitation, product features, specifications, designs, availability and pricing, are subject to change by Parker Hannifin Corporation and its subsidiaries at any time without notice.

### Offer of Sale

The items described in this document are available for sale by Parker Hannifin Corporation, its subsidiaries or its authorized distributors. Any sale contract entered by Parker will be governed by the provisions stated in Parker's standard terms and conditions of sale (copy available upon request).



**Instrumentation Products Division**  
 Autoclave Engineers Operation  
 8325 Hessinger Drive  
 Erie, Pennsylvania 16509-4679 USA  
 PH: 814-860-5700 FAX: 814-860-5811  
 www.autoclave.com

Parker Hannifin Manufacturing Ltd.  
**Instrumentation Products Division, Europe**  
 Industrial Estate Whitemill  
 Wexford, Republic of Ireland  
 PH: 353 53 914 1566  
 FAX: 353 53 914 1582

**Caution!** Do not mix or interchange parts or tubing with those of other manufacturers. Doing so is unsafe and will void warranty.

**Caution!** Parker Autoclave Engineers Valves, Fittings and Tools are not designed to work with common commercial instrument tubing and will only work with tubing built to Parker Autoclave Engineers AES Specifications. Failure to do so will void warranty.