

Highly Accurate On-Line Infrared Non-Contact Pyrometer in Two Wire Technology

CE 0°C to 1000°C

• T3-814 PL

T3-814 PL Digital Infrared Pyrometers with Thermopile Sensors provides the advantage of noncontact temperature measurement of non-metallic surfaces, painted, coated or anodized metals etc. **T3-814 PL** IR Pyrometer is designed for easy integration into standard 2 wire system. This format combines the high accuracy of digital signal processing with the simple connection. **T3-814 PL** Infrared Pyrometer is used for target temperature ranging from 0°C to 1000°C. The electronic assembly is protected by IP 65 rugged stainless steel housing.

The parameters like Emissivity can be adjusted directly at device. Other parameters like Analog Sub Range, Response Time, Peak Picker, Valley Picker etc can be preset ex-works or adjustable via Software Infracsoft. T3 Series is provided with TTL output. Using the USB interface *Infraclink* and Software pyrometer can be connected to PC for parameter setting and data logging.



Technical specifications

Model	T3-814 PL
Temperature Range (Analog sub-range adjustable)	0°C....1000°C 75°C...1000°C
Spectral Range	8 μm...14 μm
Photodetector Type	Thermopile
Distance to Spot Size Ratio	50:1 100:1
Emissivity (ε)	0.1....1.0 adjustable
Response Time	60 msec adjustable upto 10sec
Accuracy	T < 200°C; ± 1.5% of measured value or 3°C whichever is greater T ≥ 200°C; ± 1% of measured value or 4°C whichever is greater (The instrument must be at constant ambient temperature for minimum 25-30 mins in power on condition)
Repeatability	0.3% of reading in °C + 1°C
Sighting Option	Laser Pilot Light (PL)
Analog Output	2 wire....4-20mA Linear Temperature Output Load : Max 500Ω at 24V DC, Max 200Ω at 18V DC
Digital Output	TTL
Operating Temp. Range	0°C.....70°C 0°C.....200°C (With water cooling jacket)
Storage Temp. Range	-20°C...70°C
Adjustable Parameters and Features via Software	Emissivity, Response Time, Analog Scale (Sub Range), Unit of Temperature (°C/°F), Peak Picker, Valley Picker
Power Supply	24 V DC (5 to 25 V DC for Laser Targeting light (I ≤ 30 mA))
Power Consumption	For Laser Targeting Max 0.65 watt For Device Max 0.6 watt
Laser Power	<1 m watt
Protection Class	IP65
Housing	Stainless Steel
Operating Humidity	10-95%, Non-Condensing Conditions
Weight & Dimensions	250g Dia=Ø40mm; Length=113.5mm

Features

- Two wire technology for easy electrical connection
- Wide temperature range 0°C....1000°C
- Spectral range 8.0 μm....14 μm
- Laser Light for precision targeting of the measuring object
- 60 ms response time adjustable upto 10 sec
- Analog output 2 wire....4-20 mA (Isolated)
- Digital TTL output & Infracsoft software
- Small spot sizes
- Emissivity can be adjusted directly at device
- Accessories for mounting and cooling options

Standard Scope of Supply

- Pyrometer with 3 mtr. long connection cable
- Analog output 2 wire....4-20 mA
- Emissivity adjustable switch
- TTL output
- Calibration certificate, Operation manual

Optional

- Extra cable lengths
- Mechanical and Electrical Accessories
- USB Interface card & PC Software

Applications

- Plastic
- Fluids
- Rubber
- Ceramic
- Wood
- Glass
- Coated Metal
- Textiles

Spot Sizes

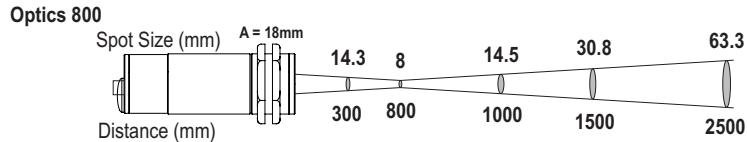
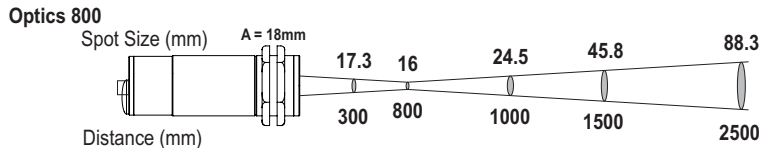
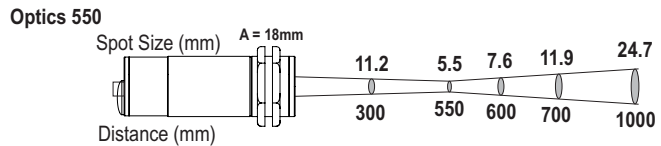
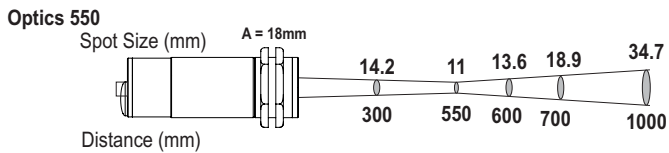
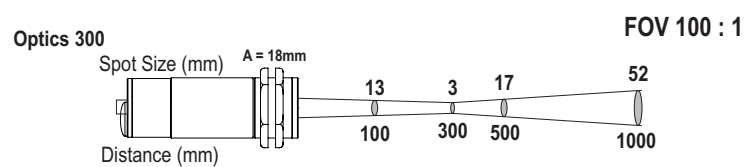
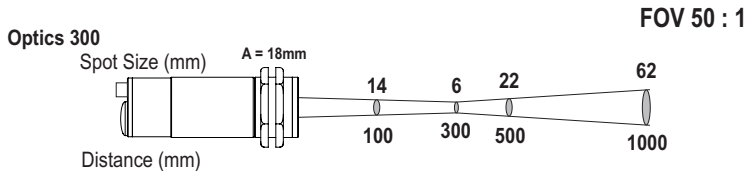

Software "Infrasoft"

AST "Infrasoft" software is provided with Infralink USB Interface accessory. It offers parameter setting, view real time graph, offline graph and to evaluate measuring data. Communication between the pyrometer and the software is implemented via USB dongle. It comes with record feature, spot size calculator and parameter settings features.

Some of the parameters adjustable via software are

- Response Time
- Picker
 - Peak
 - Valley
- Sub Range
- Unit of Temperature (°C/°F)

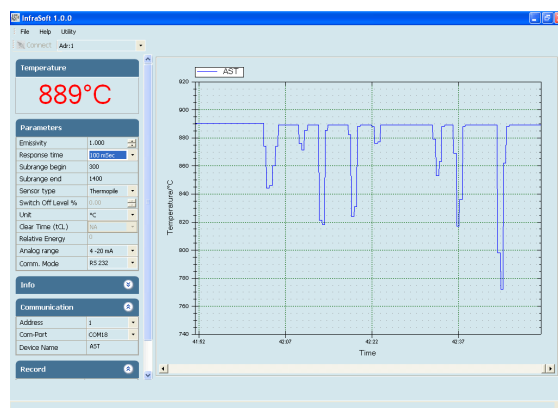

Pyrometer Drawing

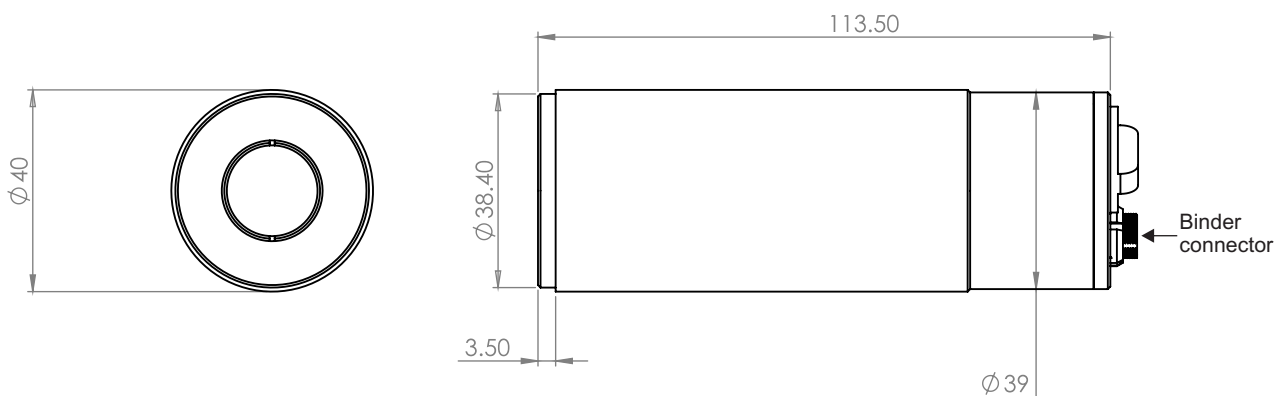

Accessories

Air Purge Unit
(Reference no. 8700-01)



Mounting Clamp
(Reference no: 8500-04)



We measure accurate temperature in extreme conditions

Accessories

Power supply Input 110/230V AC
Reference No. 9000 - 02
Output 24 V DC, 0.7Amp.



Temperature Indicator
(Reference no: 9000-01)



Pyrometer Accessories Drawings

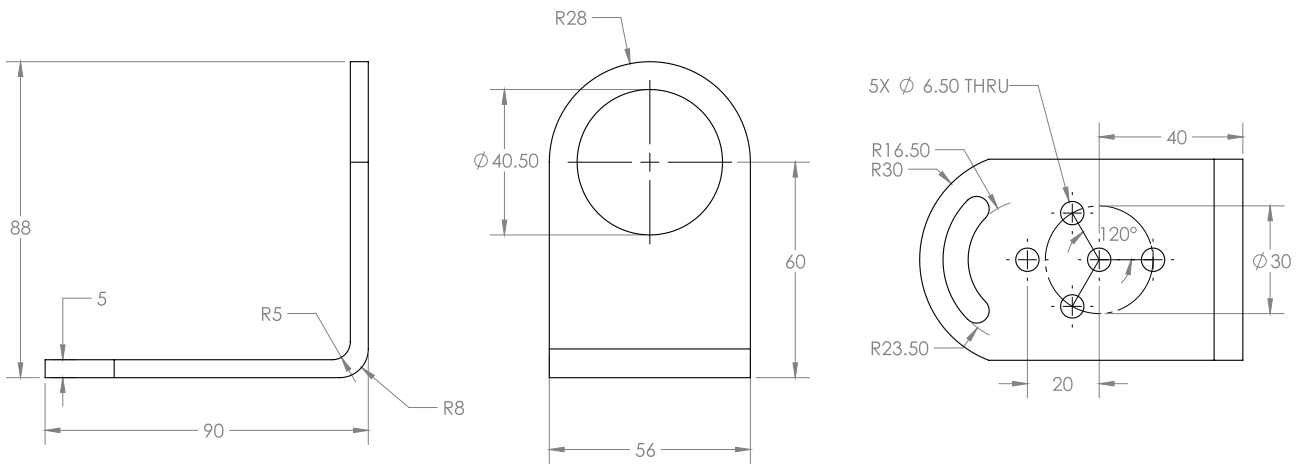

Mounting Clamp
(Reference no. 8500-04)

for 6 mm inside diameter air hose

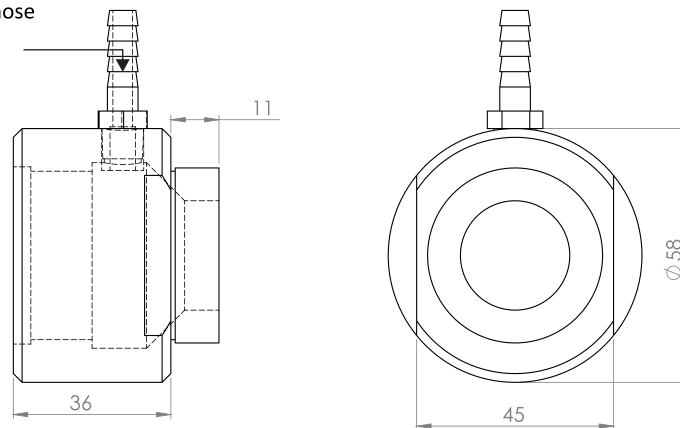

Air Purge Unit
(Reference no. 8700-01)

AST 
Accurate Sensors Technologies

Misgav Industrial Park, Misgav 20174 Israel
Ph. : +972-4-9990025, Fax : +972-4-9990031
E-mail : info@accuratesensors.com
www.accuratesensors.com



We measure accurate temperature in extreme conditions