



Anglo-Flemish Unknown Artist
'King Henry VIII'; c.1527–1550
oil on oak panel

ArtSpark

ignite ideas and imagine

Discover **'King Henry VIII'**, a painting
c. **1527–1550**, by an unknown artist.

This is one of 14,000+ works of art from the Government Art Collection which are displayed in UK Government buildings in over 130 countries; that is nearly every capital city around the world!



Ready to find out more?

Read online, download or 'pick and mix' any activities that you like. Try them at home, at school or with friends.

You don't have to do them all in one go!

Look out for this icon for 10-minute quick and easy activities...

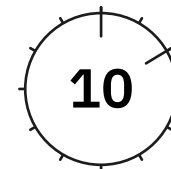



10 facts about... Henry VIII portrait

- * This portrait of King Henry VIII by an anonymous Anglo-Flemish artist is among the earliest artworks in the Government Art Collection.
- * The painting has been in a curated display of Tudor and Elizabethan figures at 10 Downing Street.
- * The inscription running along the top of the portrait includes the date '1527'. It's impossible to know if this is the painting's date, but 1527 was an important year for Henry VIII. His wife Katherine of Aragon was past child-bearing age, and his affair with Anne Boleyn was at its peak.
- * Agitated by the lack of a male heir, in January 1527, Henry set the first court challenge of his marriage before Cardinal Wolsey. Expecting to be free to wed Anne in months, in fact it took five years.
- * The Latin inscription along the top of the painting, 'HENRICUS.ANGLORUM.REX 1527' if translated exactly, identifies Henry as 'the king of the English'.
- This suggests the portrait was made for a European audience as a form of propaganda to popularise Henry as a powerful monarch.
- * Henry wears a black cord around his neck, with an item - possibly a pendant, a cross, or a jewel with initials - suspended from it and concealed inside his clothing. This way of wearing jewellery is found in other Tudor portraits, and means that the wearer knows what it is, but the people they meet can only guess. It is worth comparing this work to Holbein's portrait of Henry in the Thyssen-Bornemisza Museum, where the jewellery is fully displayed.
- * Like all outfit choices, Henry's clothing holds a lot of visual messages about power, style, luxury and quality. The fine linen shirt with asymmetric detailing; the red gown, most likely silk, lined with what may be a white cloth of gold; the bonnet decorated with small gold geometric motifs, a brooch, and opulent metal thread embroidery.
- * This portrait has had an interesting journey between England, Europe and the USA. In 1927, the famous US journalist and business mogul, William Randolph Hearst, bought it for his collection, keeping it until 1941. He was the inspiration for the 1941 film character, 'Citizen Kane'.
- * 'Provenance' is a record of ownership of a work of art, and is used as a guide to authenticity or quality. Provenance for this painting begins in 1878 - which means entire centuries are unaccounted for. From the 16th to 19th century, we can only guess where it may have hung and who saw it.
- * The character of Henry VIII has inspired countless creative artists - from painters and film-makers to playwrights and authors, including Shakespeare and Hilary Mantel.

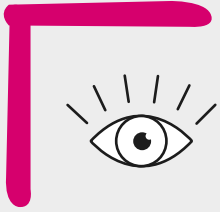

Starter questions to help explore the artwork



If a portrait is supposed to 'represent' a person, do you think this is an accurate 'representation' of Henry?

- How can you tell?
- What do you think the 'message' of this portrait is?

Take a look at photos of current celebrities:

- What do the images tell you about them?
- What impression do the images make?
- Are these accurate? If not, why not?
- How has photography and the internet affected the way we understand portraits?
- What do you think are the main differences between old and new portraits?
- What has stayed the same?

We know that portraits of Henry were offered to future wives, but how does the Latin inscription here suggest that it was not intended to woo a new partner?

Nowadays, we are used to the idea of online matchmaking - imagine if this work was intended to attract a new partner, how successful do you think it would have been (and why)?

- Does Henry look impressive in this portrait? Think of some words of your own to describe him.
- Does Henry look like a good catch? Explain your answer.

Here are some quotes about Henry. Read them as you look at the portrait. Do these descriptions of Henry affect how you 'read' his portrait?

From history:

'Most cruel and abominable tyrant'
(Pope Paul III, 1538)

'Henry is so greedy that all the riches in the world would not satisfy him...'
(Charles de Marillac, French Ambassador, 1540)

'At your age in life and with all your experience of the world you were enslaved by your passion for a girl.'
(Reginald Pole, English cardinal of the Catholic Church and the last Catholic archbishop of Canterbury, holding the office from 1556 to 1558)

From historians:

'A second-rate mind with what looks suspiciously like an inferiority complex'
(John Guy, British historian)

Filling in the fact gaps —

An advantage of not having too many facts is the space it leaves for the imagination. Think about the ‘unknowns’ for the portrait of Henry, and fill in the gaps with your imagination, doing any research you like.

- Who was the ‘anonymous Anglo-Flemish artist’?
- Where was the portrait before 1870?
- What is concealed on Henry’s pendant?

Making an impression

Henry was involved with the construction of his image through artistic commissions and the Court painters and craftsmen he employed.

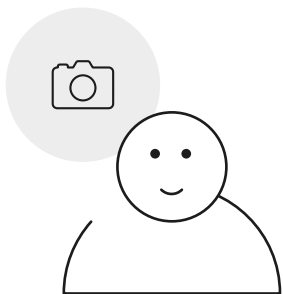

Your turn: write the life of the portrait

Write an account of what or who this portrait has ‘seen’ - for example, while on display at 10 Downing Street.

Taking it further: ‘what if?’

Develop your writer’s imagination by mixing up what you know and what you don’t know: what other mysteries can you explore, where the available information is limited?

Your turn: create a portrait of yourself

- Make a self portrait photograph as a way of introducing yourself.
- First, decide what impression you hope to make. Who do you want to impress?
- Where will you set it? Think about the room, the background, and what else is in the shot.
- What will you choose to wear? (Casual or formal? Brand names?)
- Is there anything you would prefer not to show? (Why?)
- How do you express your personality?

Your turn: make a list

In ten minutes, either solo or with a friend, come up with a list of subjects that have an element of mystery - for example, who is Banksy?

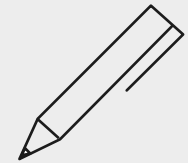
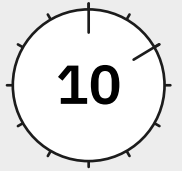

Show your portrait to your friends

- Ask them what it says about you - can they ‘read’ it?
- Did you create the impression you intended?
- What would you change if you did it again?
- How different would your portrait be for a job interview, or to send to a friend?

Build your own monarchy



Kings and queens feature on many everyday objects, from tea towels and mugs to playing cards and pub signs.

Throughout history, people have given royal titles - or 'honorific titles' - to people who are important to them, e.g. the musicians Nat 'King' Cole, and Queen Latifah.

- Can you think of others?
- Who is important in your life? Friends and family? People in your community? Or celebrities and sports people you admire? Create your own honorific royals.

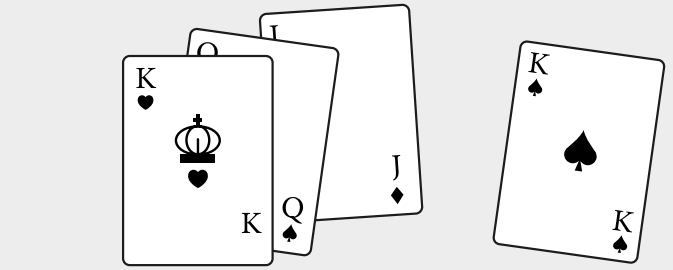

Your turn: create a set of playing cards featuring your own 'royal family'

For inspiration, look at this set of [linocuts](#) by Jeb Loy Nichols' Country Soul Playing Cards. Look at some of the [sets of playing cards](#) owned by The Worshipful Company of Makers of Playing Cards.

In 1393, King Richard II declared that all pubs and inns had to have signs that identified them to the official 'Ale Taster'. In London, Richard's emblem was the 'White Hart'. Ever since, pub names and signs have reflected moments in history. Before Henry VIII led the Reformation in England, many pub names were religious, e.g. 'The Crossed Keys', the emblem of St. Peter. After the Reformation, many religious names became 'The King's Head' or 'The Rose & Crown'.

Your turn: design a sign featuring someone who is important in your life

Transform someone you know into an illustrated sign. Find inspiration from the pose, colours or clothes of Henry VIII's portrait. Think about the style of lettering. Create a frame around your portrait.

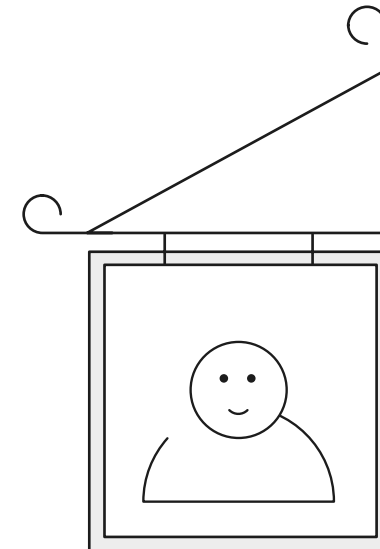

It's a rap

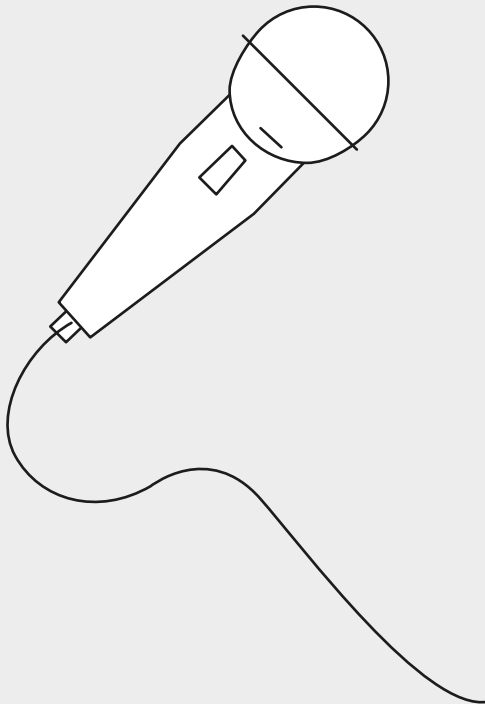

In 'Crown', British rapper, singer and songwriter Stormzy repeats the refrain:

'But heavy is the head that wears the crown.'

The words are inspired by a line from Shakespeare's play, 'Henry IV Part 2':

'uneasy lies the head that wears a crown.'

The phrase has become an English idiom (or expression) meaning that people holding great responsibility carry a heavy burden that makes it difficult for them to relax.

Talk about this

- Is having major responsibility what makes someone a king or queen?
- Why is Stormzy using the phrase? In what way does he 'wear a crown'?
- Look up the lyrics of Stormzy's 'Crown', and explore and discuss some of the subjects he references - such as The BRIT Awards; a scholarship he created for black British students; and Elle Magazine.
- Do you think these are relevant subjects for song lyrics?
- How do they explain Stormzy's views on responsibility?

- What other subjects do Stormzy's lyrics engage with?
- How/why do Stormzy's words from Shakespeare still mean something today?

Your turn: write your own rap

- Choose a personal quality you feel strongly about e.g. honesty, loyalty. Search for that quality online and find a quote that you connect with.
- Now see if you can weave the quote into a new piece of writing.
- Include details from your own experience (just as Stormzy mentions The Brits).
- Perform your piece, see what works. Work on it. Try it over music. Make sure you keep some of the original quote in there.

Off with his head



'Bling! Henry' is a painting from 'The Headless Monarch Series' by Stephen Farthing. While painting these, he realised how much court portraiture is an 'invented world': 'The greatest communication is in the understanding and rendering of the costume - whether 16th-century bling or the current gear.'

Talk about this

- Why doesn't Farthing include the head in his painting?
- Is this still a portrait, or has it become something else - and if so, what?
- How can we understand a portrait without a face?
- What are we left looking at, and what effect does it have?

Your turn: bling it up

- Create a collage of the King Henry VIII portrait, cropped in the same way as 'Bling! Henry'.
- Do what Farthing has done: crop off the head (after all, Henry beheaded his queens!)
- Draw a grid over the remaining image, and enlarge each square of the grid separately.

- Working with friends, everyone collages their own square of the grid.
- Experiment with materials e.g. sweet wrappers, fabric scraps etc. to recreate the rich textures of Henry's clothing and jewellery.
- Reassemble the squares into a new Bling! Henry.
- What is the overall effect?

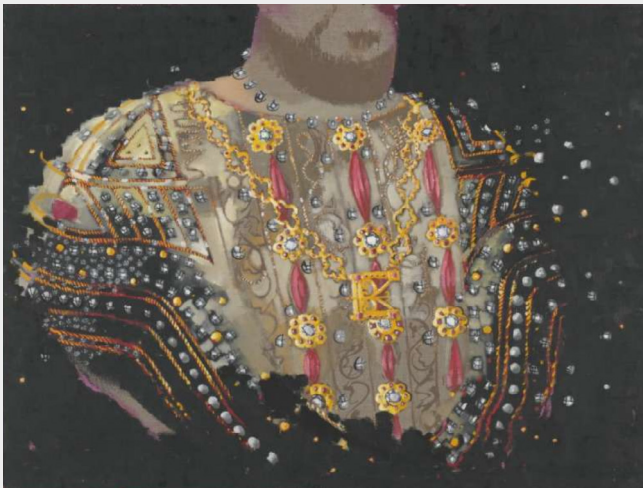

Stephen Farthing
'Bling! Henry' 2007
oil on canvas
© Stephen Farthing

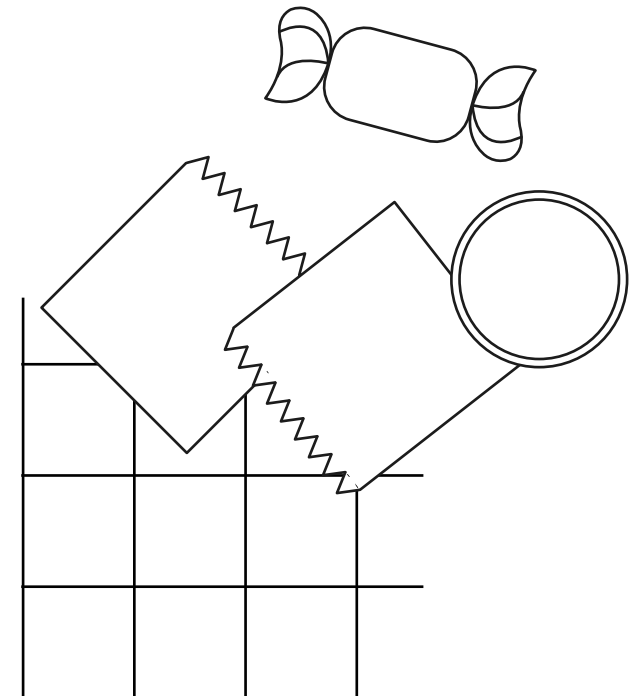

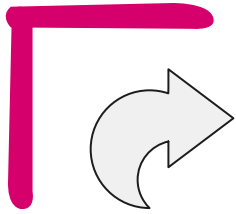

What next?

Quotations used in the resource

- Some opinions about Henry VIII
- The National Archives - online resources on Henry VIII
- BBC History extra website
- Stephen Farthing: 'The Fourth Wall' (Purdy Hicks Gallery, 2009)

Books to borrow from a library

- **'The Head That Wears a Crown: Poems about Kings and Queens'**
Eds. Rachel Piercey and Emma Dai'an Wright'
(The Emma Press, 2018)
- **'The Wolf Hall Trilogy'** Hilary Mantel
(Fourth Estate, 2009–2020)

Places to visit

- Historic Royal Palaces
(Tower of London, Hampton Court Palace, Banqueting House, Kensington Palace, Kew Palace, Hillsborough Castle)
- Royal Museums Greenwich
- Mary Rose, Portsmouth
(Excellent online resources, including 'Knit a mini Tudor hat')
- Costume Departments
As well as museums and historical buildings, many theatres have costume departments. Some open to visitors or offer rentals for historical reenactment and fancy dress occasions. Find out where your nearest/local theatre is. When they reopen in the future, support them by seeing a show, or even finding out if you can visit their costume department.

The Government Art Collection is the most dispersed collection of British art in the world. On show in UK Government buildings in nearly every capital city, the Collection promotes British art and supports British cultural diplomacy, culture and values.

- / One national collection
- / Over 14,000 artworks
- / On show in over 130 countries

www.artcollection.culture.gov.uk

Photographic credits: unless credited, all images are © Crown Copyright

GOV/ART/COL



Department for
Digital, Culture,
Media & Sport