

Technical Note

TN 1.01 Dual Wall HDPE Perforation Patterns

Overview

Perforated pipe plays an integral role in many applications of HDPE pipe. Generally, perforated pipe is used to accelerate the removal of subsurface water in soils or to allow storm water to percolate into the soil. Currently, two classifications of perforations are specified in the AASHTO material specifications for HDPE pipe: Class I, and Class II. The Class II perforation pattern comes standard when perforated pipe is ordered. Class One perforated pipe has limited availability. Please check with a local representative to determine availability. Both classes are explained in more detail in the AASHTO materials specifications (M294 and M252). AASHTO M252 covers pipe diameters 3- through 10-inch (75 - 250 mm) while M294 covers 12-inch through 60-inch (300 - 1500 mm).

Standard Perforation Patterns

AASHTO Class II Perforation

The following terminology for perforations is derived from the applicable AASHTO specification. Differences between the specifications are covered in the table below. Class II perforations shall be located in the outside valleys of the corrugations, be circular and/or slotted and evenly spaced around the circumference and length of the pipe. The perforations shall be located in the outside valleys of the corrugations. The water inlet area shall be no less than 0.945 in²/ft (20 cm²/m) for pipe diameters 4- through 10-inch (100 - 250mm), 1.42 in²/ft (30 cm²/m) for pipe diameters 12- through 18-inch (300 - 450 mm) and 1.89 in²/ft (40 cm²/m) for pipe diameters larger than and equal to 24 inches (600 mm). Table 1 below represents ADS standard perforation patterns for AASHTO Class II

Nominal I.D.	Perforation Type	Maximum Slot Length or Diameter	Maximum Slot Width	Minimum Inlet Area
4" (100 mm)	Slot	0.875" (22 mm)	0.125" (3 mm)	1.0 in ² /ft (21 cm ² /m)
6" (150 mm)	Slot	0.875" (22 mm)	0.125" (3 mm)	1.0 in ² /ft (21 cm ² /m)
8" (200 mm)	Slot	1.18" (30 mm)	0.125" (3 mm)	1.0 in ² /ft (21 cm ² /m)
10" (250 mm)	Slot	1.18" (30 mm)	0.125" (3 mm)	1.0 in ² /ft (21 cm ² /m)
12" (300 mm)	Circular	0.313" (8 mm)	-	1.5 in ² /ft (32 cm ² /m)
15" (375 mm)	Circular	0.313" (8 mm)	-	1.5 in ² /ft (32 cm ² /m)
18" (450 mm)	Circular	0.313" (8 mm)	-	1.5 in ² /ft (32 cm ² /m)
24" (600 mm)	Circular	0.313" (8 mm)	-	2.0 in ² /ft (42 cm ² /m)
30" (750 mm)	Circular	0.375" (9.5 mm)	-	2.0 in ² /ft (42 cm ² /m)
36" (900 mm)	Circular	0.375" (9.5 mm)	-	2.0 in ² /ft (42 cm ² /m)
42" (1050 mm)	Circular	0.375" (9.5 mm)	-	2.0 in ² /ft (42 cm ² /m)
48" (1200 mm)	Circular	0.375" (9.5 mm)	-	2.0 in ² /ft (42 cm ² /m)
54" (1350 mm)	Circular	0.375" (9.5 mm)	-	2.0 in ² /ft (42 cm ² /m)
60" (1500 mm)	Circular	0.375" (9.5 mm)	-	2.0 in ² /ft (42 cm ² /m)

Figure 1: AASHTO Class II Perforation Patterns

Note: Actual pattern may vary by region, however all patterns meet the AASHTO and ASTM minimum requirements for the open inlet area.

**4" - 10" (100-250 mm)
Pipe Diameters**

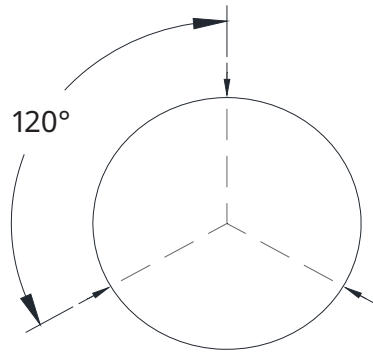

3 AT 120°

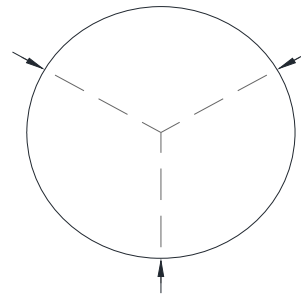

ROTATED EVERY
VALLEY

**12" - 18" (250-450 mm)
Pipe Diameters**

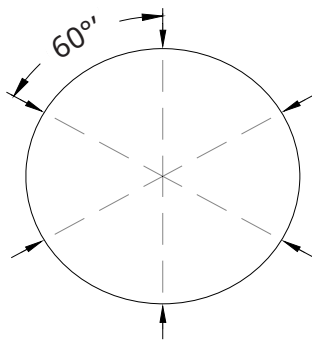

** NUMBER OF HOLES AROUND
CIRCUMFERENCE VARIES BASED ON
DIAMETER AND REGION **

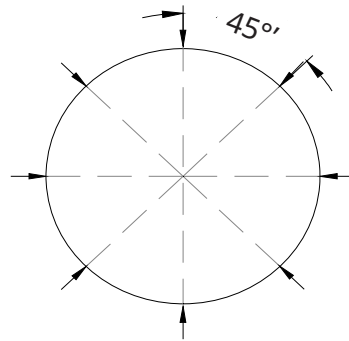

** NUMBER OF HOLES AROUND
CIRCUMFERENCE VARIES BASED ON
DIAMETER AND REGION **

**24" (600 mm)
Pipe Diameters**

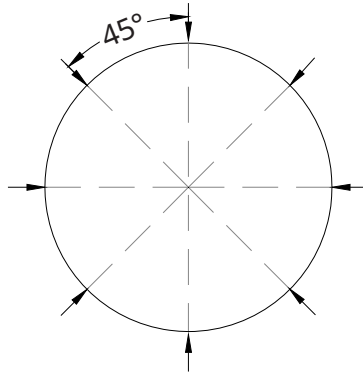

**30" (750 mm)
Pipe Diameters**

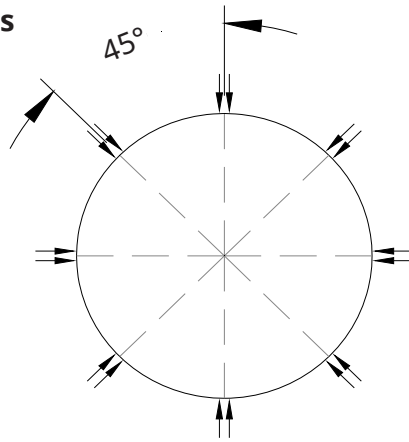
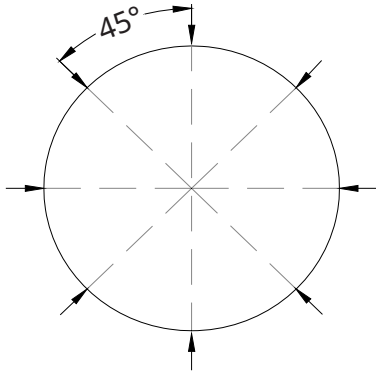

2 AT EVERY 45°

** NUMBER OF HOLES AROUND CIRCUMFERENCE
VARIES BASED ON DIAMETER AND REGION **

**36"-60" (900-1500 mm)
Pipe Diameters**

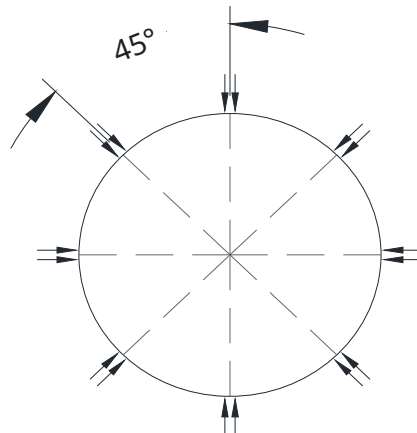

2 AT EVERY 45°

AASHTO Class I Perforation

Please contact your local ADS representative before specifying or ordering pipe with a Class I perforation pattern to verify its availability. The following terminology is derived from the applicable AASHTO specification. The perforations shall be approximately circular and arranged in rows parallel to the axis of the pipe. The locations of the perforations shall be in the valley of the outside of every corrugation. The perforations shall be arranged in two equal groups placed symmetrically on either side of the lower half of the pipe. Diameters 4"-10" are not available in Class I patterns, however your local ADS representative may be contacted to verify whether your custom pattern can be provided.

Nominal I.D.	Min. No. of Rows of Perforations	Maximum Perforation Hole Diameter	Minimum Perforation Hole Diameter	"H" Maximum	"L" Minimum	Inlet Area*
12" (300 mm)	6	0.40" (10 mm)	0.20" (10 mm)	5.5" (138 mm)	7.6" (192 mm)	1.2 in ² /ft (24.3 cm ² /m)
15" (375 mm)	6	0.40" (10 mm)	0.20" (10 mm)	6.8" (172 mm)	9.5" (240 mm)	0.9 in ² /ft (18.4 cm ² /m)
18" (450 mm)	6	0.40" (10 mm)	0.20" (10 mm)	8.2" (207 mm)	11.4" (288 mm)	0.8 in ² /ft (16.0 cm ² /m)
24" (600 mm)	8	0.40" (10 mm)	0.20" (10 mm)	10.9" (276 mm)	15.2" (384 mm)	0.9 in ² /ft (19.2 cm ² /m)
30" (750 mm)	8	0.40" (10 mm)	0.20" (10 mm)	13.6" (345 mm)	18.9" (480 mm)	0.7 in ² /ft (13.8 cm ² /m)
36" (900 mm)	8	0.40" (10 mm)	0.20" (10 mm)	16.3" (414 mm)	22.7" (576 mm)	0.6 in ² /ft (11.7 cm ² /m)
42" (1050 mm)	8	0.40" (10 mm)	0.20" (10 mm)	19.0" (483 mm)	26.5" (672 mm)	0.6 in ² /ft (12.8 cm ² /m)
48" (1200 mm)	8	0.40" (10 mm)	0.20" (10 mm)	21.8" (552 mm)	30.3" (768 mm)	0.6 in ² /ft (12.0 cm ² /m)
60" (1500 mm)	8	0.40" (10 mm)	0.20" (10 mm)	27.2" (690 mm)	37.8" (960 mm)	0.5 in ² /ft (10.1 cm ² /m)

*No minimum Inlet Area requirements from AASHTO M294. Value based on required minimum perforation hole diameter and the minimum number of perforation rows per AASHTO M294.

Figure 2: AASHTO Class I Perforation Patterns

FOR 12"-60" (300-1500 MM)
PIPE PER AASHTO M294

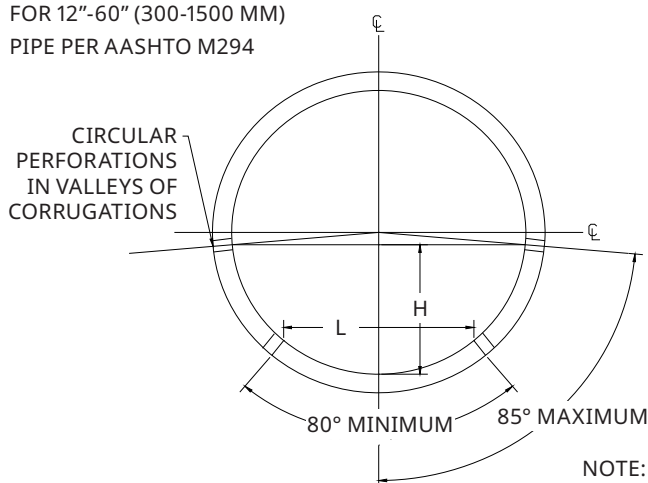

NOTE: DIAGRAM ILLUSTRATES MEASUREMENTS FOR VALUES OF "H" AND "L" - MINIMUM NUMBER OF ROWS OF PERFORATIONS IS LISTED IN TABLE ABOVE.



adspipe.com
800-821-6710