

DUAL WALL FABRICATED 11.25° BENDS
4" - 24" DIAMETER

PART #	PIPE SIZE	A	JOINT
** 0491AN	4 in (100 mm)	4.2 in (107 mm)	*
** 0691AN	6 in (150 mm)	5.0 in (127 mm)	*
** 0891AN	8 in (200 mm)	6.7 in (170 mm)	*
** 1091AN	10 in (250 mm)	7.5 in (191 mm)	*
1291AN	12 in (300 mm)	7.9 in (202 mm)	*
1291AN85B	12 in (300 mm)	4.3 in (108 mm)	ST
1291AN65B	12 in (300 mm)	4.3 in (108 mm)	WT
1591AN	15 in (375 mm)	11.0 in (280 mm)	*
1591AN85B	15 in (375 mm)	6.0 in (152 mm)	ST
1591AN65B	15 in (375 mm)	6.0 in (152 mm)	WT
1891AN	18 in (450 mm)	10.9 in (276 mm)	*
1891AN85B	18 in (450 mm)	5.8 in (148 mm)	ST
1891AN65B	18 in (450 mm)	5.8 in (148 mm)	WT
2491AN	24 in (600 mm)	14.2 in (360 mm)	*
2491AN85B	24 in (600 mm)	7.9 in (202 mm)	ST
2491AN65B	24 in (600 mm)	7.9 in (202 mm)	WT

* = PLAIN END

ST = SOIL TIGHT

WT = WATER TIGHT

** LIMITED AVAILABILITY. PLEASE SEE INJECTION MOLDED FITTING SECTION FOR OTHER AVAILABLE FITTINGS

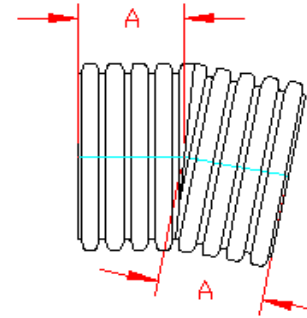

PLAIN END

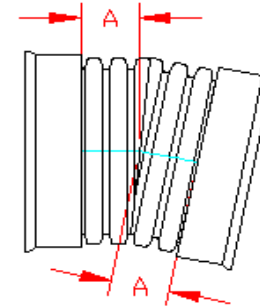

ST & WT (INCLUDES 2 GASKETS)

NOTE: ALL FITTINGS DIMENSIONS ARE FOR REFERENCE ONLY

© 2021 Advanced Drainage Systems, Inc.

 Advanced Drainage Systems, Inc.	DRAWING #:	2200	
	DRAWN BY:	JCB	04.06.06
	APPROVED BY:	JCB	06.25.07
	REVISIONS:	TJR	4/21/2016

DUAL WALL FABRICATED 11.25° BENDS
30" - 60" DIAMETER

PART #	PIPE SIZE	A	JOINT
3091AN	30 in (750 mm)	17.9 in (455 mm)	*
3091AN	30 in (750 mm)	9.7 in (246 mm)	ST
3091AN	30 in (750 mm)	9.7 in (246 mm)	WT
3691AN	36 in (900 mm)	22.3 in (567 mm)	*
3691AN85B	36 in (900 mm)	12.0 in (306 mm)	ST
3691AN65B	36 in (900 mm)	12.0 in (306 mm)	WT
4291AN	42 in (1050 mm)	17.6 in (448 mm)	*
4291AN85B	42 in (1050 mm)	12.4 in (316 mm)	ST
4291AN65B	42 in (1050 mm)	12.4 in (316 mm)	WT
4891AN	48 in (1200 mm)	18.1 in (461 mm)	*
4891AN85B	48 in (1200 mm)	12.9 in (328 mm)	ST
4891AN65B	48 in (1200 mm)	12.9 in (328 mm)	WT
6091AN	60 in (1500 mm)	21.1 in (536 mm)	*
6091AN85B	60 in (1500 mm)	15.1 in (383 mm)	ST
6091AN65B	60 in (1500 mm)	15.1 in (383 mm)	WT

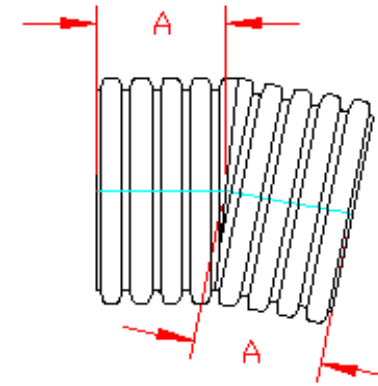

PLAIN END

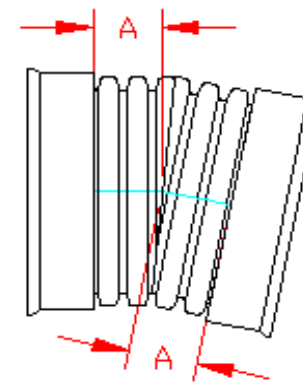

ST & WT (INCLUDES 2 GASKETS)

* = PLAIN END
ST = SOIL TIGHT
WT = WATER TIGHT

NOTE: ALL FITTINGS DIMENSIONS ARE FOR REFERENCE ONLY

© 2021 Advanced Drainage Systems, Inc.



Advanced Drainage Systems, Inc.

DRAWING #:	2200A	
DRAWN BY:	JCB	04.06.06
APPROVED BY:	JCB	06.25.07
REVISIONS:	TJR	2/2/2010

DUAL WALL FABRICATED 22.5° BENDS
4" - 30" DIAMETER

PART #	PIPE SIZE	A	JOINT
** 0492AN	4 in (100 mm)	4.5 in (114 mm)	*
** 0692AN	6 in (150 mm)	5.4 in (137 mm)	*
** 0892AN	8 in (200 mm)	7.6 in (194 mm)	*
** 1092AN	10 in (250 mm)	7.8 in (197 mm)	*
1292AN	12 in (300 mm)	9.6 in (244 mm)	*
1292AN85B	12 in (300 mm)	5.8 in (146 mm)	ST
1292AN65B	12 in (300 mm)	5.8 in (146 mm)	WT
1592AN	15 in (375 mm)	13.1 in (334 mm)	*
1592AN85B	15 in (375 mm)	5.4 in (137 mm)	ST
1592AN65B	15 in (375 mm)	5.4 in (137 mm)	WT
1892AN	18 in (450 mm)	14.3 in (363 mm)	*
1892AN85B	18 in (450 mm)	6.9 in (174 mm)	ST
1892AN65B	18 in (450 mm)	6.9 in (174 mm)	WT
2492AN	24 in (600 mm)	18.9 in (480 mm)	*
2492AN85B	24 in (600 mm)	9.5 in (240 mm)	ST
2492AN65B	24 in (600 mm)	9.5 in (240 mm)	WT

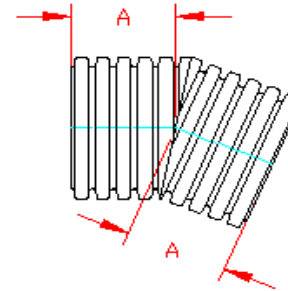

PLAIN END

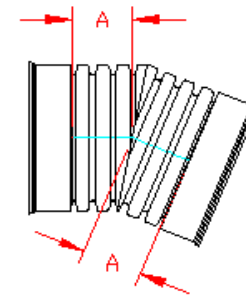

ST & WT (INCLUDES 2 GASKETS)

* = PLAIN END
 ST = SOIL TIGHT
 WT = WATER TIGHT
 ** LIMITED AVAILABILITY. PLEASE SEE INJECTION MOLDED FITTING SECTION FOR OTHER AVAILABLE FITTINGS

NOTE: ALL FITTINGS DIMENSIONS ARE FOR REFERENCE ONLY

© 2021 Advanced Drainage Systems, Inc.

 Advanced Drainage Systems, Inc.	DRAWING #:	2205	
	DRAWN BY:	JCB	04.06.06
	APPROVED BY:	JCB	06.25.07
	REVISIONS:	TJR	4/26/2016

DUAL WALL FABRICATED 22.5° BENDS
30" - 60" DIAMETER

PART #	PIPE SIZE	A	JOINT
3092AN	30 in (750 mm)	17.9 in (455 mm)	*
3092AN85B	30 in (750 mm)	9.7 in (245 mm)	ST
3092AN65B	30 in (750 mm)	9.7 in (245 mm)	WT
3692AN	36 in (900 mm)	21.5 in (546 mm)	*
3692AN85B	36 in (900 mm)	11.2 in (285 mm)	ST
3692AN65B	36 in (900 mm)	11.2 in (285 mm)	WT
4292AN	42 in (1050 mm)	24.9 in (632 mm)	*
4292AN85B	42 in (1050 mm)	14.5 in (369 mm)	ST
4292AN65B	42 in (1050 mm)	14.5 in (369 mm)	WT
4892AN	48 in (1200 mm)	23.8 in (605 mm)	*
4892AN85B	48 in (1200 mm)	13.9 in (353 mm)	ST
4892AN65B	48 in (1200 mm)	13.9 in (353 mm)	WT
6092AN	60 in (1500 mm)	33.2 in (844 mm)	*
6092AN85B	60 in (1500 mm)	15.2 in (387 mm)	ST
6092AN65B	60 in (1500 mm)	15.2 in (387 mm)	WT

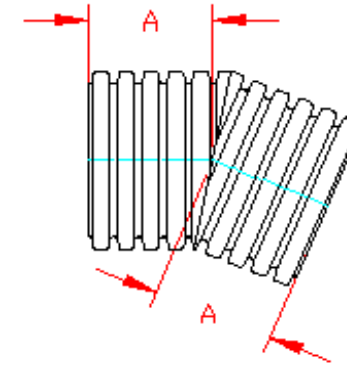

PLAIN END

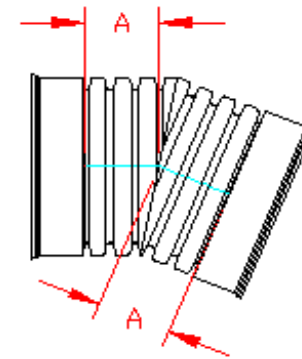

ST & WT (INCLUDES 2 GASKETS)

* = PLAIN END
 ST = SOIL TIGHT
 WT = WATER TIGHT

NOTE: ALL FITTINGS DIMENSIONS ARE FOR REFERENCE ONLY

© 2021 Advanced Drainage Systems, Inc.



DRAWING #:	2205A	
DRAWN BY:	JCB	04.06.06
APPROVED BY:	JCB	06.25.07
REVISIONS:	TJR	1/29/2010

DUAL WALL FABRICATED 30° BENDS
4" - 24" DIAMETER

PART #	PIPE SIZE	A	JOINT
** 0495AN	4 in (100 mm)	4.6 in (116 mm)	*
** 0695AN	6 in (150 mm)	5.5 in (139 mm)	*
** 0895AN	8 in (200 mm)	7.4 in (189 mm)	*
** 1095AN	10 in (250 mm)	8.4 in (214 mm)	*
1295AN	12 in (300 mm)	9.7 in (245 mm)	*
1295AN85B	12 in (300 mm)	5.8 in (146 mm)	ST
1295AN65B	12 in (300 mm)	5.8 in (146 mm)	WT
1595AN	15 in (375 mm)	12.4 in (315 mm)	*
1595AN85B	15 in (375 mm)	7.8 in (197 mm)	ST
1595AN65B	15 in (375 mm)	7.8 in (197 mm)	WT
1895AN	18 in (450 mm)	12.4 in (316 mm)	*
1895AN85B	18 in (450 mm)	6.7 in (170 mm)	ST
1895AN65B	18 in (450 mm)	6.7 in (170 mm)	WT
2495AN	24 in (600 mm)	15.9 in (404 mm)	*
2495AN85B	24 in (600 mm)	9.5 in (240 mm)	ST
2495AN65B	24 in (600 mm)	9.5 in (240 mm)	WT

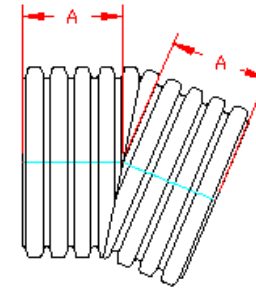

PLAIN END

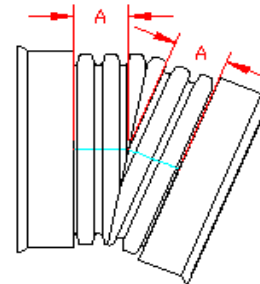

ST & WT (INCLUDES 2 GASKETS)

* = PLAIN END

ST = SOIL TIGHT

WT = WATER TIGHT

** LIMITED AVAILABILITY. PLEASE SEE INJECTION MOLDED FITTING SECTION FOR OTHER AVAILABLE FITTINGS

NOTE: ALL FITTINGS DIMENSIONS ARE FOR REFERENCE ONLY

© 2021 Advanced Drainage Systems, Inc.

	DRAWING #:	2210	
	DRAWN BY:	JCB	04.06.06
	APPROVED BY:	JCB	06.25.07
	REVISIONS:	TJR	4/26/2016

DUAL WALL FABRICATED 30° BENDS
30" - 60" DIAMETER

PART #	PIPE SIZE	A	JOINT
3095AN	30 in (750 mm)	20.6 in (523 mm)	*
3095AN85B	30 in (750 mm)	13.5 in (342 mm)	ST
3095AN65B	30 in (750 mm)	13.5 in (342 mm)	WT
3695AN	36 in (900 mm)	25.9 in (658 mm)	*
3695AN85B	36 in (900 mm)	15.4 in (392 mm)	ST
3695AN65B	36 in (900 mm)	15.4 in (392 mm)	WT
4295AN	42 in (1050 mm)	22.3 in (567 mm)	*
4295AN85B	42 in (1050 mm)	17.1 in (435 mm)	ST
4295AN65B	42 in (1050 mm)	17.1 in (435 mm)	WT
4895AN	48 in (1200 mm)	22.7 in (576 mm)	*
4895AN85B	48 in (1200 mm)	17.4 in (442 mm)	ST
4895AN65B	48 in (1200 mm)	17.4 in (442 mm)	WT
6095AN	60 in (1500 mm)	26.0 in (661 mm)	*
6095AN85B	60 in (1500 mm)	20.0 in (508 mm)	ST
6095AN65B	60 in (1500 mm)	20.0 in (508 mm)	WT

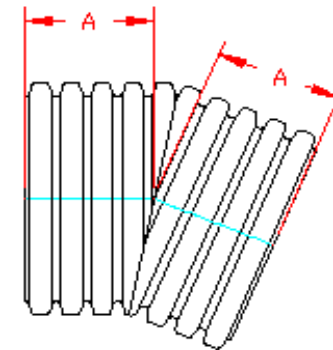

PLAIN END

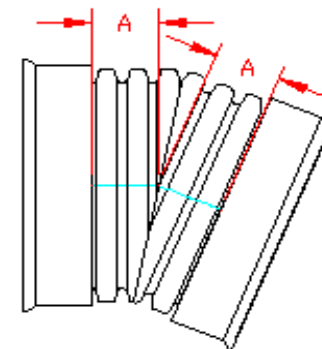

ST & WT (INCLUDES 2 GASKETS)

* = PLAIN END
ST = SOIL TIGHT
WT = WATER TIGHT

NOTE: ALL FITTINGS DIMENSIONS ARE FOR REFERENCE ONLY

© 2021 Advanced Drainage Systems, Inc.



DRAWING #:	2210A	
DRAWN BY:	JCB	04.06.06
APPROVED BY:	JCB	06.25.07
REVISIONS:	TJR	1/29/2010

DUAL WALL FABRICATED 45° BENDS
4" - 30" DIAMETER

PART #	PIPE SIZE	A	JOINT
** 0494AN	4 in (100 mm)	4.2 in (107 mm)	*
** 0694AN	6 in (150 mm)	5.0 in (126 mm)	*
** 0894AN	8 in (200 mm)	6.7 in (170 mm)	*
** 1094AN	10 in (250 mm)	7.5 in (189 mm)	WT
1297AN	12 in (300 mm)	11.5 in (293 mm)	*
1297AN65BB	12 in (300 mm)	5.8 in (146 mm)	WT
1597AN	15 in (375 mm)	13.0 in (329 mm)	*
1597AN65BB	15 in (375 mm)	7.8 in (197 mm)	WT
1897AN	18 in (450 mm)	17.4 in (443 mm)	*
1897AN65BB	18 in (450 mm)	6.7 in (170 mm)	WT
2497AN	24 in (600 mm)	22.1 in (560 mm)	*
2497AN65BB	24 in (600 mm)	9.5 in (240 mm)	WT
3097AN	30 in (750 mm)	25.8 in (656 mm)	*
3097AN65BB	30 in (750 mm)	13.5 in (342 mm)	WT

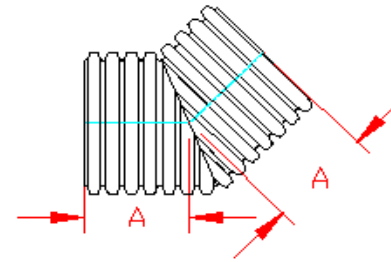

PLAIN END

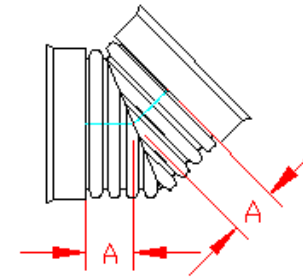

ST & WT (INCLUDES 2 GASKETS)

* = PLAIN END

WT = WATER TIGHT

** LIMITED AVAILABILITY. PLEASE SEE INJECTION MOLDED FITTING SECTION FOR OTHER AVAILABLE FITTINGS

NOTE: ALL FITTINGS DIMENSIONS ARE FOR REFERENCE ONLY

© 2021 Advanced Drainage Systems, Inc.

	DRAWING #:	2212	
	DRAWN BY:	JCB	04.06.06
	APPROVED BY:	JCB	06.25.07
	REVISIONS:	TJR	4/26/2016

DUAL WALL FABRICATED 45° BENDS
36" - 60" DIAMETER

PART #	PIPE SIZE	A	JOINT
3697AN	36 in (900 mm)	29.3 in (745 mm)	*
3697AN65BB	36 in (900 mm)	13.6 in (345 mm)	WT
4297AN	42 in (1050 mm)	31.1 in (791 mm)	*
4297AN65BB	42 in (1050 mm)	19.2 in (487 mm)	WT
4897AN	48 in (1200 mm)	30.2 in (767 mm)	*
4897AN65BB	48 in (1200 mm)	19.7 in (500 mm)	WT
6097AN	60 in (1500 mm)	42.0 in (1067 mm)	*
6097AN65BB	60 in (1500 mm)	24.0 in (610 mm)	WT

* = PLAIN END
 WT = WATER TIGHT

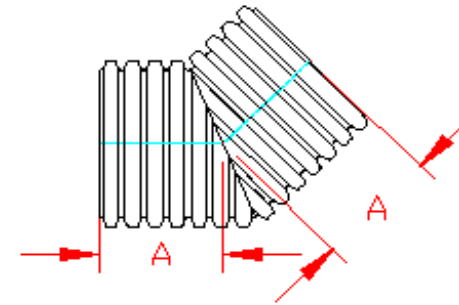

PLAIN END

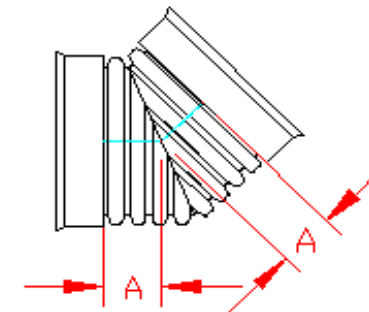

ST & WT (INCLUDES 2 GASKETS)

NOTE: ALL FITTINGS DIMENSIONS ARE FOR REFERENCE ONLY

© 2021 Advanced Drainage Systems, Inc.



DRAWING #:	2212A	
DRAWN BY:	JCB	04.06.06
APPROVED BY:	JCB	06.25.07
REVISIONS:	TJR	1/29/2010

DUAL WALL FABRICATED MITERED 45° BENDS
12" - 30" DIAMETER

PART #	PIPE SIZE	A	B	JOINT
1294AN	12 in (300 mm)	9.6 in (244 mm)	7.7 in (195 mm)	*
1294AN85B	12 in (300 mm)	5.8 in (146 mm)	7.7 in (195 mm)	ST
1294AN65B	12 in (300 mm)	5.8 in (146 mm)	7.7 in (195 mm)	WT
1594AN	15 in (375 mm)	13.1 in (334 mm)	8.5 in (216 mm)	*
1594AN85B	15 in (375 mm)	5.4 in (137 mm)	8.5 in (216 mm)	ST
1594AN65B	15 in (375 mm)	5.4 in (137 mm)	8.5 in (216 mm)	WT
1894AN	18 in (450 mm)	14.3 in (363 mm)	8.6 in (219 mm)	*
1894AN85B	18 in (450 mm)	6.9 in (174 mm)	8.6 in (219 mm)	ST
1894AN65B	18 in (450 mm)	6.9 in (174 mm)	8.6 in (219 mm)	WT
2494AN	24 in (600 mm)	18.9 in (480 mm)	12.6 in (320 mm)	*
2494AN85B	24 in (600 mm)	9.5 in (240 mm)	12.6 in (320 mm)	ST
2494AN65B	24 in (600 mm)	9.5 in (240 mm)	12.6 in (320 mm)	WT
3094AN	30 in (750 mm)	17.9 in (455 mm)	15.2 in (386 mm)	*
3094AN85B	30 in (750 mm)	9.7 in (245 mm)	15.2 in (386 mm)	ST
3094AN65B	30 in (750 mm)	9.7 in (245 mm)	15.2 in (386 mm)	WT

* = PLAIN END
 ST = SOIL TIGHT
 WT = WATER TIGHT

NOTE: ALL FITTINGS DIMENSIONS ARE FOR REFERENCE ONLY

© 2021 Advanced Drainage Systems, Inc.

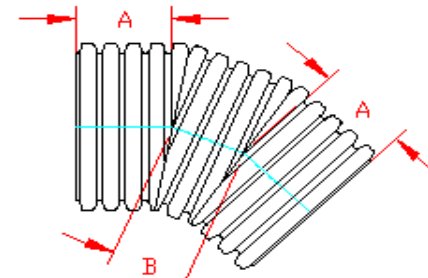

PLAIN END

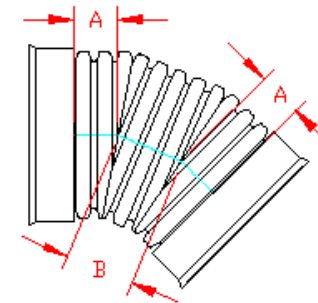

ST & WT (INCLUDES 2 GASKETS)

 Advanced Drainage Systems, Inc.	DRAWING #:	2215
	DRAWN BY:	JCB 04.06.06
	APPROVED BY:	JCB 06.25.07
	REVISIONS:	TJR 4/26/2016

DUAL WALL FABRICATED MITERED 45° BENDS
36" - 60" DIAMETER

PART #	PIPE SIZE	A	B	JOINT
3694AN	36 in (900 mm)	21.5 in (546 mm)	17.3 in (439 mm)	*
3694AN85B	36 in (900 mm)	11.2 in (285 mm)	17.3 in (439 mm)	ST
3694AN65B	36 in (900 mm)	11.2 in (285 mm)	17.3 in (439 mm)	WT
4294AN	42 in (1050 mm)	24.9 in (632 mm)	18.7 in (474 mm)	*
4294AN85B	42 in (1050 mm)	14.5 in (369 mm)	18.7 in (474 mm)	ST
4294AN65B	42 in (1050 mm)	14.5 in (369 mm)	18.7 in (474 mm)	WT
4894AN	48 in (1200 mm)	24.4 in (620 mm)	22.6 in (574 mm)	*
4894AN85B	48 in (1200 mm)	13.9 in (353 mm)	22.6 in (574 mm)	ST
4894AN65B	48 in (1200 mm)	13.9 in (353 mm)	22.6 in (574 mm)	WT
6094AN	60 in (1500 mm)	33.2 in (844 mm)	24.5 in (622 mm)	*
6094AN85B	60 in (1500 mm)	15.2 in (387 mm)	24.5 in (622 mm)	ST
6094AN65B	60 in (1500 mm)	15.2 in (387 mm)	24.5 in (622 mm)	WT

* = PLAIN END
 ST = SOIL TIGHT
 WT = WATER TIGHT

NOTE: ALL FITTINGS DIMENSIONS ARE FOR REFERENCE ONLY

© 2021 Advanced Drainage Systems, Inc.

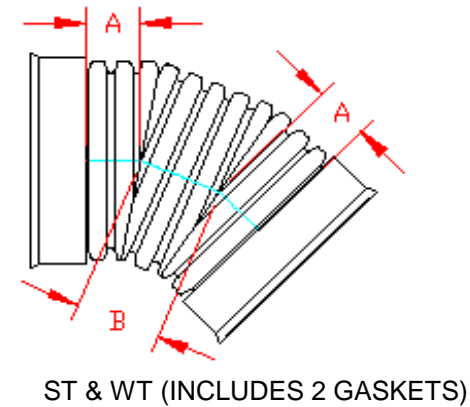
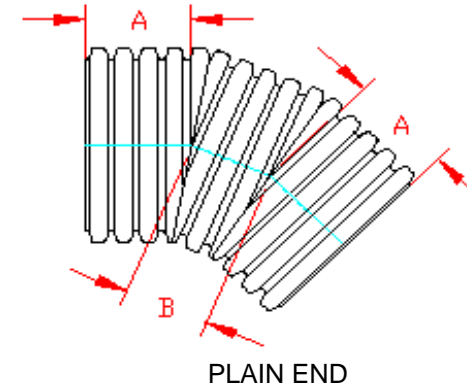

ADS Advanced Drainage Systems, Inc.	DRAWING #:	2215A
	DRAWN BY:	JCB 04.06.06
	APPROVED BY:	JCB 06.25.07
	REVISIONS:	NJP 06.14.07

SMALL DIAMETER DUAL WALL FABRICATED BENDS
4" - 10" DIAMETER

90° BENDS

PART #	PIPE SIZE	A	JOINT
** 0499AN	4 in (100 mm)	4.5 in (114 mm)	*
** 0699AN	6 in (150 mm)	5.4 in (137 mm)	*
** 0899AN	8 in (200 mm)	7.6 in (194 mm)	*
** 1099AN	10 in (250 mm)	7.8 in (197 mm)	*

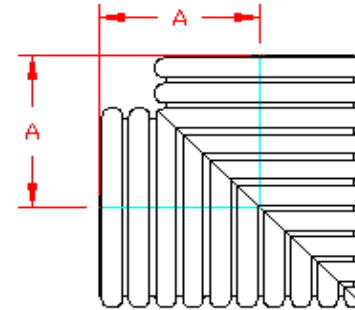

* = PLAIN END

** LIMITED AVAILABILITY. PLEASE SEE INJECTION MOLDED FITTING SECTION FOR OTHER AVAILABLE FITTINGS

NOTE: ALL FITTINGS DIMENSIONS ARE FOR REFERENCE ONLY

© 2021 Advanced Drainage Systems, Inc.

	DRAWING #:	2217
	DRAWN BY:	JCB 05.09.07
	APPROVED BY:	JCB 06.29.07
	REVISIONS:	TJR 2/10/2010

DUAL WALL FABRICATED "WATER TIGHT" "BELL-BELL" 90° BENDS
12" - 60" DIAMETER

PART #	PIPE SIZE	A
1298AN65B	12 in (300 mm)	10.8 in (273 mm)
1598AN65B	15 in (375 mm)	11.8 in (300 mm)
1898AN65B	18 in (450 mm)	14.7 in (373 mm)
2498AN65B	24 in (600 mm)	17.7 in (450 mm)
3098AN65B	30 in (750 mm)	22.4 in (570 mm)
3698AN65B	36 in (900 mm)	26.2 in (666 mm)
4298AN65B	42 in (1050 mm)	36.0 in (914 mm)
4898AN65B	48 in (1200 mm)	39.3 in (997 mm)
6098AN65B	60 in (1500 mm)	39.0 in (991 mm)

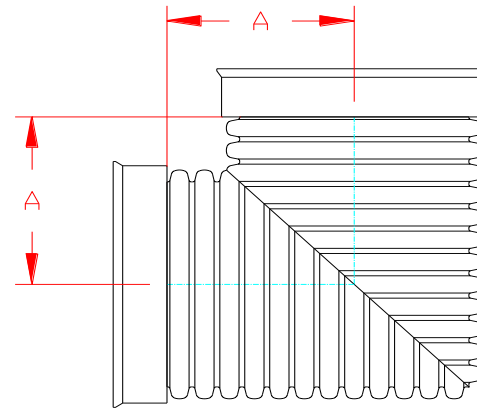

(INCLUDES 2 GASKETS)

NOTE: ALL FITTINGS DIMENSIONS ARE FOR REFERENCE ONLY

© 2021 Advanced Drainage Systems, Inc.

	DRAWING #:	2218
	DRAWN BY:	TJR 11.14.13
	APPROVED BY:	CKM 11.14.13
	REVISIONS:	TJR 4/26/2016

DUAL WALL FABRICATED MITERED 90° BENDS
12" - 18" DIAMETER

PART #	PIPE SIZE	A	B	JOINT
1299AN	12 in (300 mm)	9.4 in (239 mm)	7.8 in (198 mm)	*
1299AN85B	12 in (300 mm)	5.5 in (140 mm)	7.8 in (198 mm)	ST
1299AN65B	12 in (300 mm)	5.5 in (140 mm)	7.8 in (198 mm)	WT
1599AN	15 in (375 mm)	12.1 in (307 mm)	9.3 in (236 mm)	*
1599AN85B	15 in (375 mm)	6.9 in (175 mm)	9.3 in (236 mm)	ST
1599AN65B	15 in (375 mm)	6.9 in (175 mm)	9.3 in (236 mm)	WT
1899AN	18 in (450 mm)	12.2 in (310 mm)	10.0 in (254 mm)	*
1899AN85B	18 in (450 mm)	7.1 in (180 mm)	10.0 in (254 mm)	ST
1899AN65B	18 in (450 mm)	7.1 in (180 mm)	10.0 in (254 mm)	WT

* = PLAIN END
 ST = SOIL TIGHT
 WT = WATER TIGHT

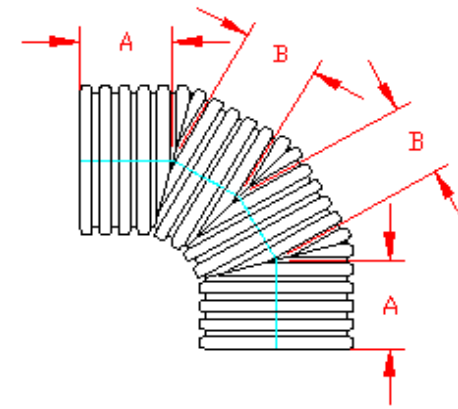

PLAIN END

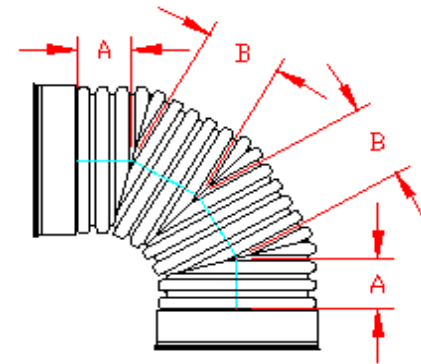

ST & WT (INCLUDES 2 GASKETS)

NOTE: ALL FITTINGS DIMENSIONS ARE FOR REFERENCE ONLY

© 2021 Advanced Drainage Systems, Inc.



DRAWING #:	2220	
DRAWN BY:	JCB	04.06.06
APPROVED BY:	JCB	06.25.07
REVISIONS:	TJR	4/26/2016