

SELECTION & APPLICATION OF SELF-PRIMING CENTRIFUGAL PUMPS

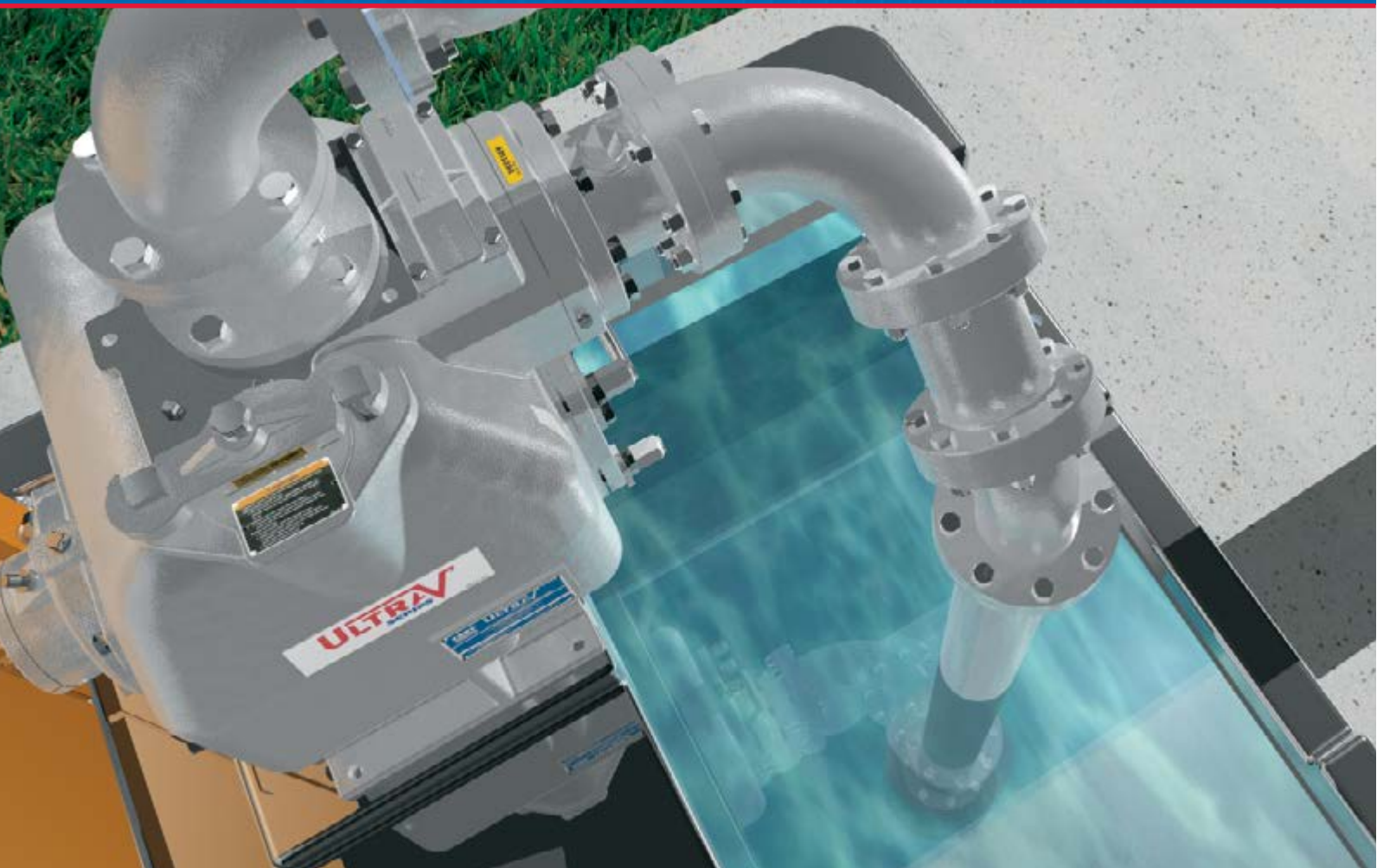

The Pump People®



PUMP SELECTION

To assist with the selection of self-priming pumps, we have created the following hypothetical example. We believe the problem and its solution to be typical of a job that might confront engineers and users.

We shall assume there is a requirement for a wastewater collection system that will require a lift station to pump the wastewater to a pretreatment collection system.

The following data were acquired by actual accurate measurements.

SYSTEM REQUIREMENTS

Flow: 200 gpm (12.6 lps)
Solids: 3" (76.2 mm)
Configuration: Duplex, one pump for standby
Site Elevation: 5280' (1609.3 m) above sea level

SYSTEM CONDITIONS

Static Suction Lift

15' (4.6 m) vertical distance from low liquid level to center line of pump suction.

Suction Pipe

17' (5.2 m), 4" (100 mm) C.I. pipe. Measured from end of suction pipe to pump suction.

90° L.R. elbow and 45° elbow equivalent to 11.5' (3.5 m) of 4" (100 mm) C.I. pipe (for friction loss calculation).

Static Discharge Head

7.5' (2.3 m) vertical distance from center line of pump suction to invert of discharge outlet.

Discharge Pipe

500' (152.4 m), 4" (100 mm) C.I. pipe. Measured from pump discharge outlet.

90° L.R. discharge elbow, check valve and gate valve equivalent to 49.8' (15.2 m) of 4" (100 mm) C.I. pipe (for friction loss calculation).

Priming Lift

10' (3.0 m) measured from high liquid level to center line of pump suction.

The accumulation of the preceding data now permits calculating the Total Dynamic Suction Lift (TDSL), Total Discharge Head (TDH), and Net Positive Suction Head (NPSH) using the worksheets on the following pages.

SELF-PRIMING | THE SENSIBLE SOLUTION

CHOOSE FROM A FULL LINE OF SELF-PRIMING CENTRIFUGAL PUMPS

Drive Variations:

- Basic
- V-Belt
- Flexible Coupled
- Engine-Driven

Self-priming pumps are a sensible solution for industrial and municipal applications. They require very little attention, resulting in significant savings of maintenance time and money.

Gorman-Rupp self-priming centrifugal pumps are easy to install and easy to service. Because they're self-priming, they can be mounted high and dry at floor level with only the suction line in the liquid – there's never a need for service personnel to enter the sump. When service or maintenance is required, it can be completed easily with common hand tools. There are no long drive shafts to install and align, and no hoists or cranes are required.

Gorman-Rupp self-priming pumps are available as basic units for connection to your power source or may be flex-coupled, v-belt driven or engine mounted.

Automatic priming means dependable performance.

All that's needed is an initial priming and the pump will continue to reprime automatically. In fact, our trash handling pumps will reprime with only a partially filled pump casing and a completely dry suction line!

Our reputation for quality has made Gorman-Rupp the world's leader in self-priming centrifugal pumps. In addition, it makes us your best solution – meeting all of your industrial or municipal waste handling needs.

Ultra V Series® High-Heads Solids-Handling



Ultra V Series® self-priming, centrifugal trash pumps handle 200% more pressure and provide 60% increased flow. Self-cleaning features, reduced footprint and unique configuration capabilities allow these pumps to excel in high-head situations where traditional pumps fall short.

Size: 3" (75 mm) to 6" (150 mm)
Max. Capacity: 1900 gpm (123 lps)
Max. Head: 168' (51 m)
Max Solids: 3" (76.2 mm)

Super T Series® Solids-Laden Liquids and Slurries



Super T Series® pumps feature a large volute design which allow them to reprime automatically in a completely open system without the need for suction or discharge check valves – and they can do it with the pump casing only partially filled with liquid and a completely dry suction line.

Size: 2" (50 mm) to 10" (250 mm)
Max. Capacity: 3400 gpm (214.5 lps)
Max. Head: 130' (39.6 m)
Max Solids: 3" (76.2 mm)

Super U Series® High Efficiency Solids and Corrosive Liquids



Super U Series® self-priming pumps are among the most efficient solids-handling, self-priming pumps available (up to 75%). Open, multivane impeller will handle solids up to 1-1/4" (31.8 mm) in diameter.

Size: 3" (75 mm) to 6" (150 mm)
Max. Capacity: 1500 gpm (95 lps)
Max. Head: 207' (63.1 m)
Max. Solids: 1.25" (31.8 mm)

80 Series® Limited Solids and Corrosive Liquids



80 Series® self-priming pumps are designed for high-efficiency, nonstop workloads. Straight-in suction design allows them to operate on higher suction levels than standard self-priming centrifugals.

Size: 1.25" (32 mm) to 6" (150 mm)
Max. Capacity: 2800 gpm (177 lps)
Max. Head: 205' (62 m)
Max. Solids: 2.5" (60.3 mm)

10 Series® Solids and Corrosive Liquids



10 Series® self-priming pumps have only two moving parts – impeller and shaft – so maintenance problems are minimal.

Size: 1.5" (37.5 mm) to 12" (300 mm)
Max. Capacity: 6000 gpm (378.6 lps)
Max. Head: 170' (51.8 m)
Max. Solids: 3" (76.2 mm)

0 Series® Clear Liquids



0 Series® self-priming pumps feature straight-in suction which eliminates entrance restrictions and provides better suction performance when handling solvents, petroleum products and similar liquids.

Size: 2" (50 mm) to 6" (150 mm)
Max. Capacity: 1350 gpm (85.2 lps)
Max. Head: 400' (121.9 m)
Max. Solids: .688" (17 mm)

1 HOW TO COMPUTE THE TOTAL DYNAMIC HEAD (TDH)

TOTAL DYNAMIC SUCTION LIFT: A + B = C

A. Static Suction Lift		15.00' (4.6 m)
B. Friction, Suction (Consult Hydraulic Handbook)		
1. Pipe, Total Length, 4" (100 mm) C.I.	17.00' (5.2 m)	
2. Fittings in Equivalent Length of Pipe		
a. One 90° L.R. Elbow, 4"–6.8' (100 mm–2.1 m)	11.50' (3.5 m)	
b. One 45° Elbow, 4"–4.7' (100 mm–1.4 m)		
3. Total Pipe (Actual & Equivalent)	28.50' (8.7 m)	
4. Total Friction Loss (.285' × 4.43' × .71') (.09 m × 1.4 m × .22 m) (based on friction coefficient C = 100, 4.43/100' and correction factor to C = 120 = .71)		.90' (.27 m)
C. Total Dynamic Suction Lift		15.90' (4.8 m)

TOTAL DISCHARGE HEAD: D + E = F

D. Static Discharge Head		7.50' (2.3 m)
E. Friction, Discharge or Force Main Line (Consult Hydraulic Handbook)		
1. Pipe, Total Length, 4" (100 mm) C.I.	500.00' (152.4 m)	
2. Fittings in Equivalent Length of Pipe		
a. One 90° L.R. Elbow, 4"–6.8' (100 mm–2.1 m)		
b. One Check Valve, 4"–26' (100 mm–7.9 m)		
c. One Plug Valve, 4"–17' (100 mm–5.2 m)	49.80' (15.2 m)	
3. Total Pipe (Actual & Equivalent)	549.80' (167.6 m)	
4. Total Friction Loss (5.5' × 4.43' × .71') (1.7 m × 1.4 m × .22 m) (based on friction coefficient C = 100, 4.43/100' and correction factor to C = 120 = .71)		17.30' (5.3 m)
F. Total Dynamic Discharge Head		24.80' (7.5 m)

TOTAL DYNAMIC HEAD: C + F = TDH

C. Total Dynamic Suction Lift	15.90' (4.8 m)	
F. Total Dynamic Discharge Head	+24.80' (7.5 m)	
Total Dynamic Head		40.70' (12.4 m)

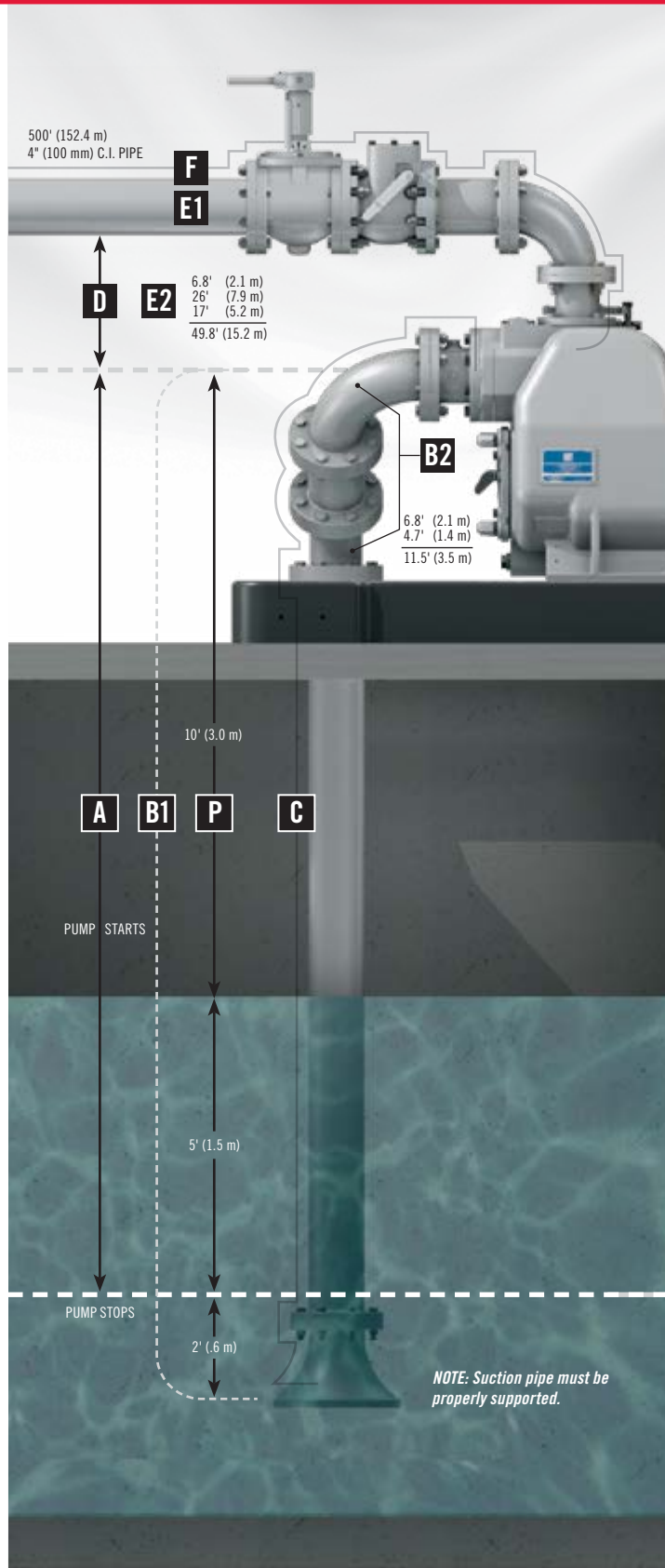

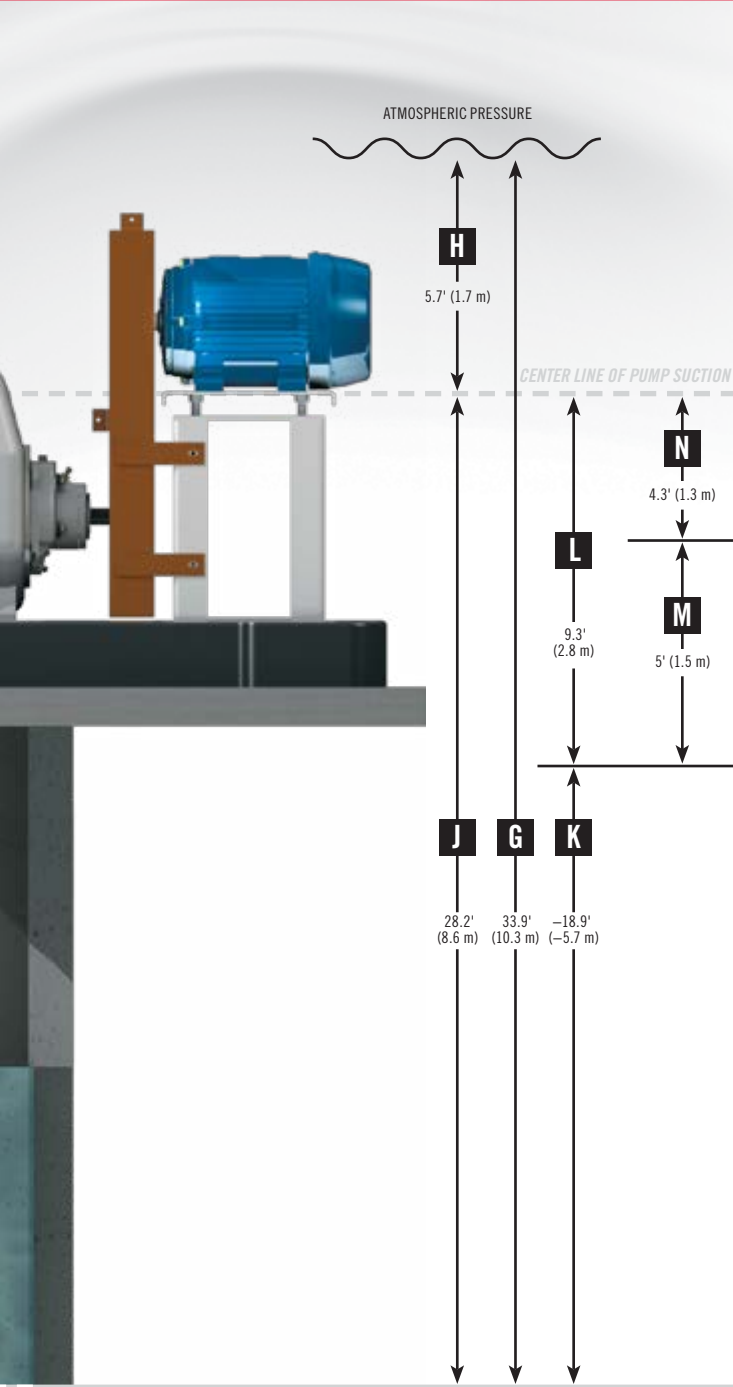

2 HOW TO COMPUTE THE NET POSITIVE SUCTION HEAD (NPSH)

	Detailed Computation
G. Atmospheric pressure (at sea level)	33.90' (10.3 m)
H. Atmospheric pressure corrected to 5280' (1609 m) [site elevation]	-5.70' (-1.7 m)
J. Atmospheric pressure available at job site (G-H)	28.20' (8.6 m)
Deductions from available atmospheric pressure:	
1. Total dynamic suction lift	15.90' (4.8 m)
2. Vapor pressure 74° liquid	1.00' (.30 m)
3. Safety factor (may vary based on local regulations)	2.00' (.61 m)
K. Total net deductions from available atmospheric pressure (1 + 2 + 3)	-18.90' (-5.7 m)
L. NPSH Available (J-K)	9.30' (2.8 m)
M. NPSH Required (see performance curves)	-5.00' (-1.5 m)
N. NPSH Excess Available, or excess atmospheric pressure (L-M)	4.30' (1.3 m)

NOTE: Items M and N cannot be determined until pumps are selected.

HOW TO DETERMINE THE PRIMING LIFT

P. Priming lift	10.00' (3.0 m)
-----------------	--------------------------

NOTE: Priming lift is measured from the high liquid level to the center line of the pump suction. Priming lift has no relation to net positive suction head.

3 SELECTING THE CORRECT PUMP

After you've made the necessary calculations, you are ready to choose the correct pump for the application.

Capacity	200 gpm (12.6 lps)
Total Dynamic Head (TDH)	40.70' (12.4 m)
Total Dynamic Suction Lift (TDSL)	15.90' (4.8 m)
Priming Lift	10.00' (3.0 m)
Net Positive Suction Head (NPSH) Available	9.30' (2.8 m)
Spherical Solids	3" (76.2 mm)

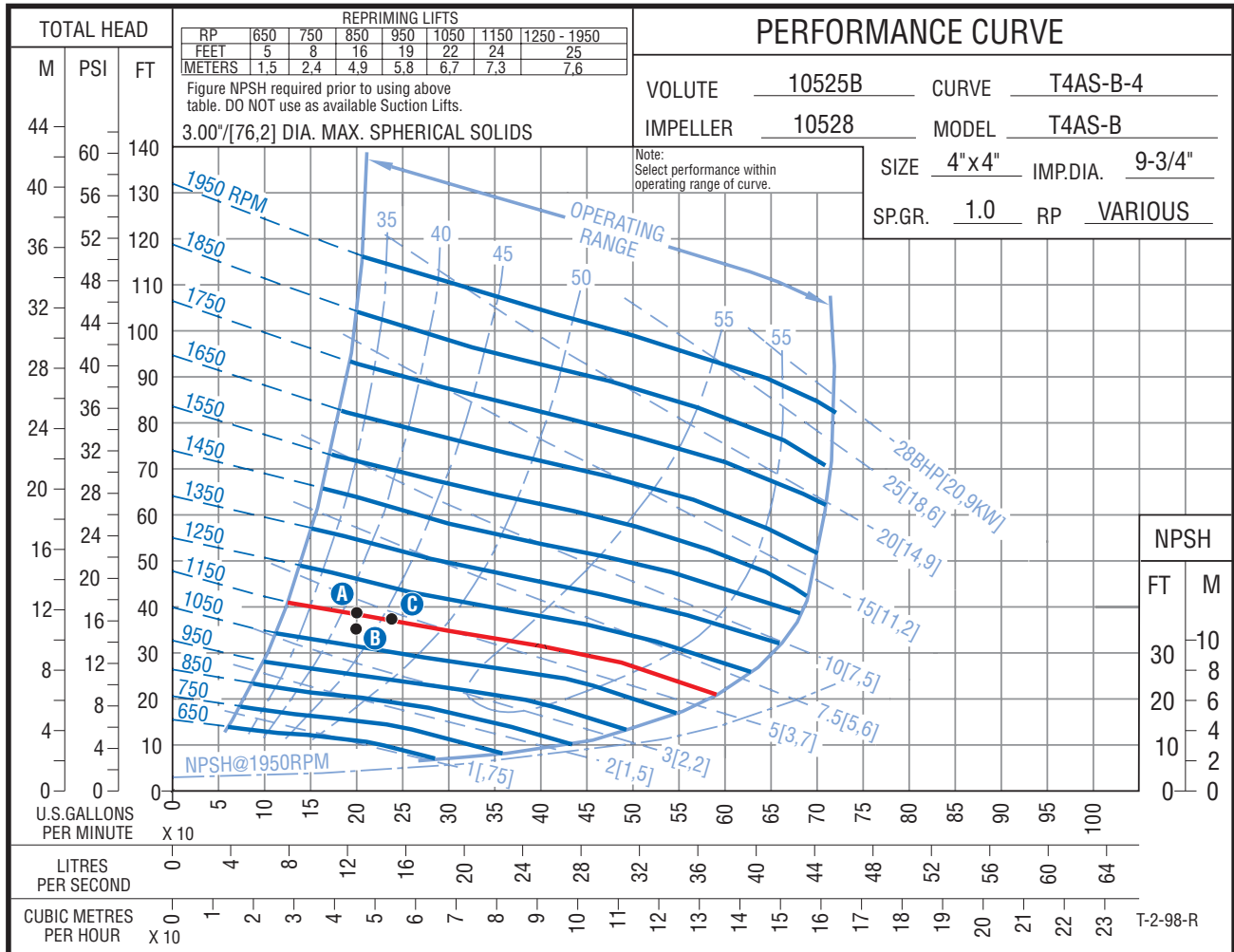

The 3" (76 mm) spherical solids requirement suggests a model T4AS-B. A typical Super T curve is shown. A 9-3/4" (250 mm) diameter impeller, turning at 1150 RPM, would be a good selection. This is a standard motor on 60 hertz frequency. It may be flex-coupled to the pump; however, for versatility, it may be v-belt driven. Note NPSH requirement of 5' (1.5 m) well within the available NPSH of 9.30' (2.8 m). The maximum repriming characteristic of the 9-3/4" (250 mm) diameter impeller at 1150 RPM is 24' (7.3 m) (see priming performance data on each curve). We require only 10' (3 m) of priming lift.

CONCLUSION:

Model T4AS-B pump, equipped with a 9-3/4" (250 mm) diameter impeller, turning at 1150 RPM, is the correct selection.

4 SELECTING THE CORRECT MOTOR

Calculating the correct motor size for a pump involves the use of a complicated formula. To make this process easier, many manufacturers add brake horsepower (or kilowatt) lines to their performance curves. Referring to point **A** on the curve, the closest non-overloading horsepower line represents 5 brake horsepower (BHP) or 3.7kW.

A good rule of thumb to use when selecting motors is to apply a motor which will provide sufficient power to cover the entire length of the selected pump curve (a practice which results in a “non-overloading” motor selection). Using our example, the selected operating speed of the pump is 1150 RPM. The performance of a pump will follow along this speed curve but will vary due to normal pump wear and changes in sump level. The calculation below accounts for the sump level change between the pump on and off levels.

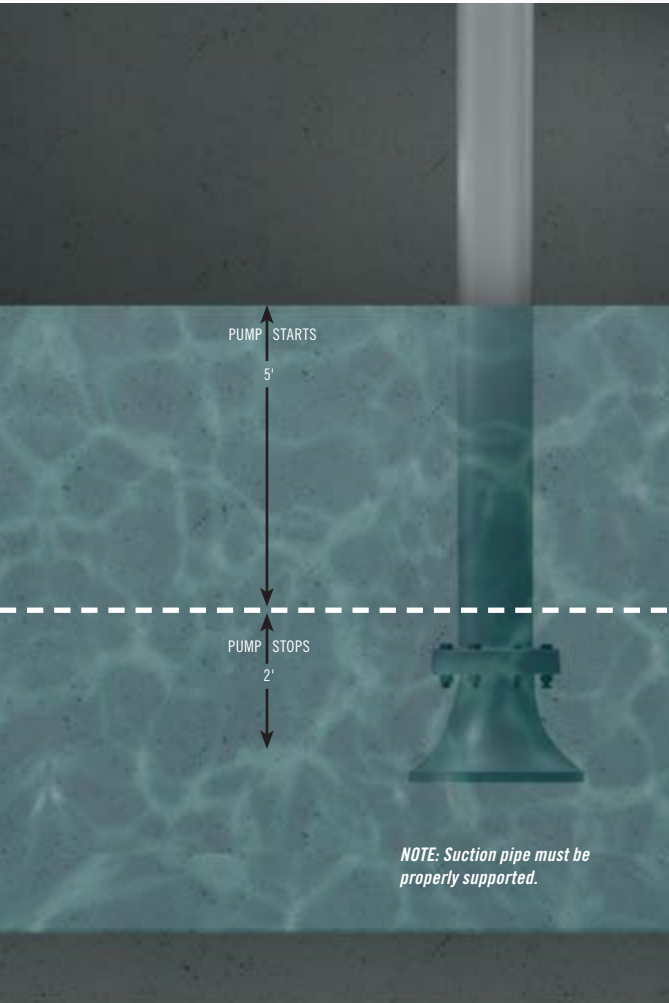

TDH AT THIS LEVEL 35.70' (10.9 m)

$$\begin{array}{r} 40.70' \text{ (12.4 m)} \\ -5.00' \text{ (-1.5 m)} \\ \hline 35.70' \text{ (10.9 m)} \end{array}$$

or: 36' (11.0 m) TDH at point **B** on curve.

TDH AT THIS LEVEL 40.70' (12.4 m)

See **A** on curve.

The change shown above is basically a change in static head. The actual performance of the pump is illustrated on the curve where the 1150 RPM curve and hydraulic system curve intersects (this is noted on the curve as point **C**). The difference in flow rate between points **A** and **C** is the band our selected pump will operate within from the beginning to the end of the pumping cycle.

Taking all this information into consideration, the best course of action is to select a 7½ HP (5.5kW) motor to ensure non-overloading operation throughout the pump's operating range.

E L E M E N T S O F A P U M P I N G S T A T I O N

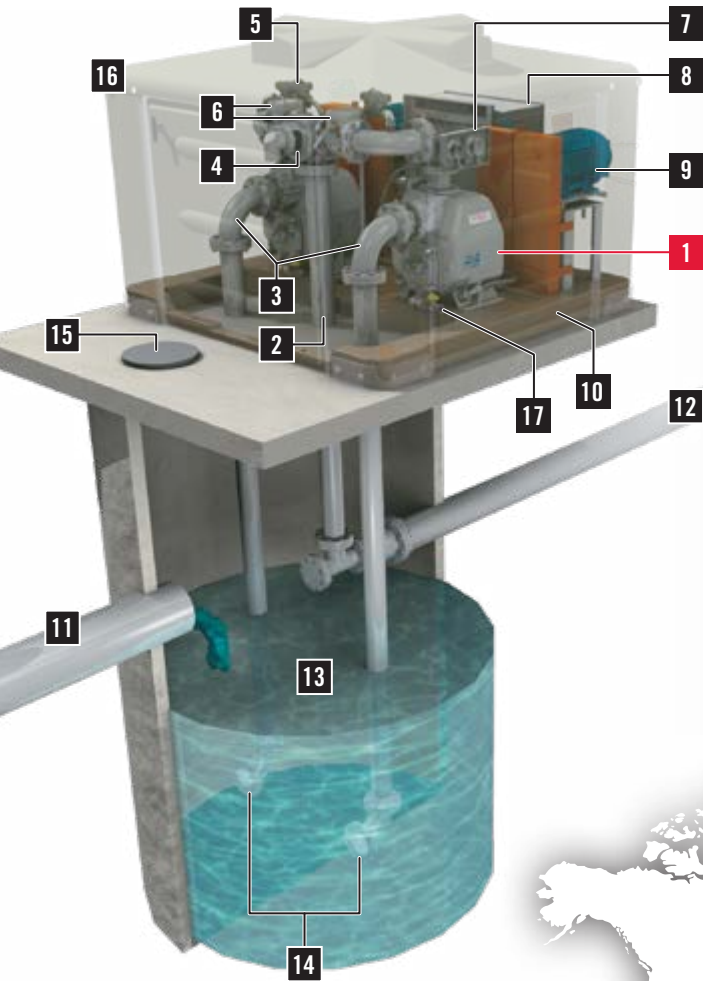

Although the pump is the heart of a pumping station, other elements should be considered when designing a system. This example identifies some of the items that can make up a system.

- | | |
|--|---|
| 1. Pump (2) | 8. Control Panel |
| 2. Discharge Pipe | 9. Electric Motor (2) |
| 3. Suction Pipe | 10. Base |
| 4. 3-Way Valve (1) | 11. Inlet Pipe |
| 5. Air Release Valve (2) | 12. Discharge/Force Main |
| 6. Discharge Check Valve (2) | 13. Sump/Wet Well |
| 7. Gauge Kit – Suction and Discharge (2) | 14. Suction Flare L.R. 90° Bend or Flange & Flare |
| | 15. Entrance to Sump/Wet Well |
| | 16. Pump Station Enclosure |
| | 17. Pump Drain Kit |

SOLD AND SERVICED THROUGHOUT THE WORLD

Gorman-Rupp has nearly 1,000 distributors worldwide who are qualified to give expert advice on pump selection and application. If you have a service problem, a factory-trained distributor is only a phone call away. Our distributors are backed by the fastest parts service in the industry so your parts will be there when you need them.



- ★ Manufacturing Facilities
- Distribution Centers

Gorman-Rupp Pumps
Mansfield, Ohio, USA

Gorman-Rupp Canada
St. Thomas, Ontario, Canada

Gorman-Rupp Europe
Culemborg, Netherlands
Namur, Belgium

Gorman-Rupp Africa
Cape Town, South Africa
Durban, South Africa
Johannesburg, South Africa (Headquarters)

Distribution Centers
Dubai, United Arab Emirates
Grand Prairie, Texas, USA



Gorman-Rupp Pumps
P.O. Box 1217
Mansfield, Ohio 44901-1217 | USA
Tel: 419.755.1011 | Fax: 419.755.1251

GRpumps.com



The Pump People®