

Handbook for Design

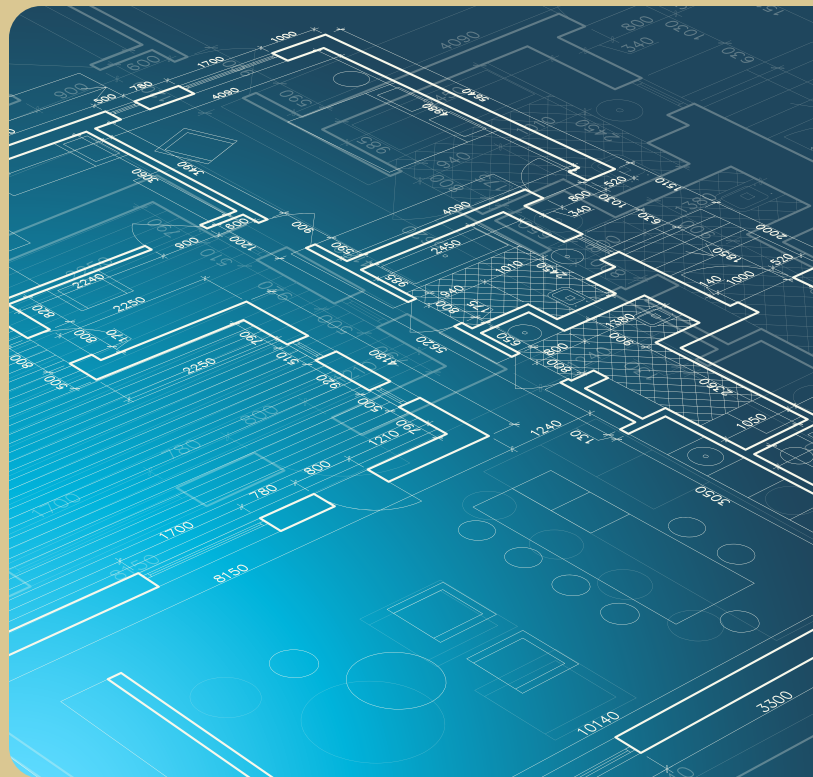

A Guide for
Specially Adapted Housing
(SAH) and Special Housing
Adaptation (SHA) Projects



VA



U.S. Department of Veterans Affairs
Veterans Benefits Administration



Feedback

VA encourages feedback from any source in regards to the contents of this handbook. Such input will allow for the continual updating and improvement of this pamphlet and will contribute to the overall quality of Veterans’ homes. Feedback should be directed to:



By Mail:
U.S. Department of Veterans Affairs
Veterans Benefits Administration (262)
810 Vermont Avenue
Washington, DC 20420



or Email
sahinfo.vbaco@va.gov

My suggestions are:

Handbook for Design

A Guide for
Specially Adapted Housing
(SAH) and Special Housing
Adaptation (SHA) Projects

VA



U.S. Department
of Veterans Affairs

VA Pamphlet 26-13
Revised September 2021

U. S. Department of Veterans Affairs
Veterans Benefits Administration
Washington, D.C. 20420

Contents

2	Section 1: Program Overview	
	Introduction.....	2
	SAH Grant.....	3
	SHA Grant.....	4
	TRA Grant.....	4
	Maximum Grant Amounts and Maximum Number of Uses.....	5
	Statutory Requirements.....	6
	Administration.....	6
7	Section 2: Information for Veterans and Service members	
	Overview.....	7
	How to Apply and Eligibility.....	8
	Initial Interview.....	9
	Feasibility and Suitability.....	9
	Conditional Approval.....	11
	Final Approval.....	12
17	Section 3: Information for Builders and Architects/Designers	
	Overview.....	17
	Bid Process.....	18
	Project Development.....	19
	Project Management.....	26
28	Section 4: VA Compliance Inspectors and Compliance Inspections	
	Overview.....	28
	Purpose of a Compliance Inspection....	29
	VA Compliance Inspector Qualifications ..	29
	Assignment of Work.....	29
	Completing a Compliance Inspection...	31
	Reporting a Compliance Inspection	31
	Non-compliance and Re-Inspections ...	32
	Determining the Accuracy of a Compliance Inspection.....	33
	Final Field Review.....	33
34	Section 5: SAH Minimum Property Requirements	
	Overview.....	34
	Ingress and Egress Requirements.....	36
	Primary Bathroom Requirements.....	39
	Primary Bedroom/Sleeping Area Requirements.....	41
	Condominiums and Townhouses.....	42
44	Section 6: SAH Recommended Adaptations	
	Overview.....	44
	Specifications for Ingress and Egress ...	45
	Specifications for Living Quarters.....	47
	Recommended Adaptations for Burn Injuries or Respiratory Related Injuries..	51
52	Section 7: SHA Recommended Adaptations	
	Overview.....	52
	Blindness in Both Eyes with Qualifying Factors.....	53
	Recommended Adaptations for Loss, or Loss of Use, of Both Hands.....	56
	Recommended Adaptations for Burn Injuries and Respiratory-Related Injuries.....	56
	Recommended Adaptations for Secondary Disabilities.....	56
57	Section 8: Grant Plans and Determining the Grant Amount	
	Overview.....	57
	SAH Plan Types.....	58
	SHA Plan Types.....	60
	Regional Loan Center Contact Information.....	62

Foreword

★ Intention

This pamphlet provides assistance to Veterans and Service members eligible for the Specially Adapted Housing (SAH), Special Housing Adaptation (SHA), and Temporary Residence Adaptation (TRA) grants administered by the Department of Veterans Affairs (VA). In addition to providing important program information to Veterans and Service members, this pamphlet will serve as a resource for VA's business partners, such as architects, designers, builders, and VA compliance inspectors, who play a critical role in delivering this benefit. VA hopes that the information presented in this pamphlet will increase sensitivity to the needs of our Veterans and Service members, facilitate awareness of the program requirements, and help expedite the grant approval process.

The information in this pamphlet is presented in eight sections and relates to grant processing, detailed design concepts, minimum property requirements (MPRs), recommended adaptations (RAs), and project management. The MPRs and RAs presented are not intended to unnecessarily restrict the architect's, or designer's overall freedom of design. Because each Veteran or Service member has unique needs and there are a wide range of possible designs, it is difficult to formulate universal design requirements. The final design of any adapted home should not call undue attention to the necessary design features, but be noteworthy for its architectural excellence and ability to meet the Veteran's or Service member's specific needs.

★ Use

This pamphlet allows for quick reference to requirements for each program participant and specific areas of design. We recommend that program participants read the entire pamphlet to become familiar with the entire grant process and the needs of the Veteran or Service member. This pamphlet should then be reviewed with the Veteran or Service member to determine which recommendations are applicable to his or her individual needs.

★ Important Note

This document is meant for information purposes only and does not establish laws, regulations, or policies related to the SAH program. Title 38 United States Code, Chapter 21, provides the statutory authority for the SAH Grant Program:

- United States House of Representatives Office of the Law Revision Council (<http://uscode.house.gov/browse/prelim@title38/part2&edition=prelim>).
- Title 38 Code of Federal Regulations § 36.4400 et al. contains the regulatory authority for the SAH grant program: Government Printing Office Code of Federal Regulations (<https://www.govinfo.gov/content/pkg/CFR-2013-title38-vol2/xml/CFR-2013-title38-vol2-part36-subpartC.xml>).
- Policies specific to the SAH program are presented in VA Manual M26-12, Specially Adapted Housing Grant Processing Procedures, Loan Guaranty Operations for Regional Offices (http://www.benefits.va.gov/WARMS/M26_12.asp).



Section 1: Program Overview



Introduction

The Specially Adapted Housing program helps Veterans with certain permanent and total service-connected disabilities purchase or construct an adapted home, or modify an existing home to accommodate a disability. The program was established in 1948 and initially focused on Veterans with total service-connected disabilities causing paralysis in the legs or lower body. Over the years, Congress expanded the legal authority of this benefit to include active duty Service members, to increase the range of disabilities that qualify individuals for assistance, to make family members' homes eligible for adaptation, and to make the benefit available to eligible individuals residing outside the continental United States (OCONUS). Today, three grants exist:

- Specially Adapted Housing (SAH) Grant
- Special Housing Adaptations (SHA) Grant
- Temporary Residence Adaptation (TRA) Grant



SAH Grant

The SAH grant is designed primarily to assist Veterans with impaired mobility and certain severe burn injuries. It may be used to (1) construct a specially adapted home on land to be acquired, (2) build a home on land already owned if it is suitable for SAH, (3) remodel an existing home if it can be made suitable for SAH, or (4) purchase, or apply the grant against the unpaid principal mortgage balance, of a home that is already adapted. The following represent the permanent and total service-connected disabilities that may qualify a Veteran for an SAH grant:

- Loss, or loss of use, of both lower extremities such as to preclude locomotion without the aid of braces, crutches, canes, or a wheelchair, or
- Blindness in both eyes, having central visual acuity of 20/200 or less in the better eye with the use of a standard correcting lens, or
- Loss or loss of use of one lower extremity, PLUS residuals of organic disease or injury, which so affect the functions of balance or propulsion as to preclude locomotion without the aid of braces, crutches, canes, or a wheelchair, or
- Loss or loss of use of one lower extremity, PLUS loss or loss of use of one upper extremity, which so affect the functions of balance or propulsion as to preclude locomotion without the aid of braces, crutches, canes, or a wheelchair, or
- Loss, or loss of use, of both upper extremities such as to preclude use of the arms at or above the elbows, or
- A severe burn injury (as determined pursuant to regulations prescribed by the Secretary), or
- Loss, or loss of use, of one or more lower extremities due to service on or after September 11, 2001, which so affects the functions of balance or propulsion as to preclude ambulating without the aid of braces, crutches, canes, or a wheelchair. (Only 120 Veterans and Service members each fiscal year (FY) can qualify for a grant based on the loss of one extremity after September 11, 2001, as set by Congress.)



Did you know?

Additional Housing Adaptation Assistance

In addition to the SAH/SHA/TRA grants, the SAH program also manages home adaptations on behalf of the **Veteran Readiness and Employment (VR&E) program**. VR&E may provide home adaptations to individuals who are not currently able to work because of the effects of their service-connected disabilities, or who require adaptations to achieve a vocational goal. The benefits are limited to those required to improve independence at home and/or in the community. Home adaptations up to the maximum VR&E grant amount may be provided as part of an approved rehabilitation plan.

To learn more about VR&E home adaptation grants and apply for VR&E benefits, please visit www.benefits.va.gov/vocrehab/independent_living.asp.



SHA Grant

The SHA grant is designed primarily to assist Veterans who are blind, who have lost the use of their hands, or who have certain severe burn or respiratory injuries. It may be used to

- (1) adapt a home that will be acquired,
- (2) adapt a home that a family member will acquire,
- (3) adapt a home that is already owned,
- (4) adapt a home that is already owned by a family member, or
- (5) purchase, or reduce the unpaid balance on the cost of a home that has already been adapted with special features that VA has determined are reasonably necessary.

The following represent the service-connected disabilities that may qualify a Veteran for an SHA grant:

- A permanent and total disability that includes the anatomical loss or loss of use of both hands, or
- Certain respiratory ailments, or
- A permanent and total disability that is due to a severe burn injury (as so determined).



TRA Grant

The TRA grant is available to help SAH or SHA eligible Veterans who are, or will be, **temporarily residing** in a home owned by a family member.

The qualifying disabilities for the TRA grant are the same as for SAH and SHA. In other words, a Veteran must be eligible for SAH or SHA in order to be eligible for TRA grant use. For TRA purposes, a family member is defined as a person related to the Veteran by blood, marriage, or adoption.

Maximum Grant Amounts and Maximum Number of Uses

The SAH, SHA, and TRA benefit amounts are set by law, but may be adjusted upward annually based on a cost-of-construction index. The index utilized reflects a uniform, national average change in the cost of residential home construction.

To find the most current maximum dollar amounts available for each of the grant types, refer to the SAH webpage here: <https://www.va.gov/housing-assistance/disability-housing-grants/>:

Maximum Grant Usages	
Grant Type	Number of Uses
Specially Adapted Housing	6
Special Housing Adaptations	6
Temporary Residence Adaptation (SAH Eligible)	1*
Temporary Residence Adaptation (SHA Eligible)	1*

* Counts as one of six available uses for the SAH or SHA grant.

No individual may use the SAH or SHA grant more than six times up to the maximum dollar amount allowable. The TRA grant does not count against the maximum dollar amount available, but it can be used only once and counts as one of the six available uses.

Example 1: A Veteran used \$50,000 of SAH grant funds in 2010 to adapt his/her home. Based on the current maximum dollar amount allowable in FY 2019 (\$85,645), the Veteran had \$35,645 available for adaptations in remaining. If the maximum grant amount increases in subsequent years, additional funds would be available. However, the Veteran is limited to six total uses of the SAH grant. The sum of the six uses cannot exceed the maximum dollar amount allowable.

Example 2: An SAH eligible Veteran, recently separated from service, decides to live temporarily with a family member until he/she purchases or builds a home. The Veteran may use the TRA grant, up to \$37,597 in FY 2019, to adapt his/her family member's home. The Veteran would still have five uses and the full amount of the SAH grant remaining for future use on his/her own home.

Statutory Requirements

In addition to the disability requirements, dollar, and use limitations discussed previously, there are certain statutory requirements that must be met to reach final grant approval. These requirements will be discussed in greater detail in the next section of the pamphlet but they include:

- Feasibility and Suitability Requirements
- Ownership Requirements
- Minimum Property Requirements (MPR)

Administration

The SAH grant program is administered by Loan Guaranty Service (LGY), which is part of the Veterans Benefits Administration. There are eight Regional Loan Centers (RLCs) located throughout the United States and grants are assigned based on geographic location.

For a complete list of each RLC, a breakdown of their jurisdiction, and contact information, please visit the VA Home Loan website at:

http://www.benefits.va.gov/HOMELOANS/contact_rlc_info.asp

One of the hallmarks of the SAH program is personalized service. LGY personnel, namely SAH Agents, are located throughout the United States and report to one of the eight Regional Loan Centers (RLCs). Once a Veteran has received entitlement for the SAH or SHA grant, his or her case will be assigned to an SAH Agent that will personally meet with the Veteran in his or her home, thoroughly explain the program requirements, assess the Veteran's needs, collect required documents, and assist the Veteran in reaching final grant approval. The SAH Agent is considered an expert in the field of adapted housing and will also work closely with the builder and architect selected by the Veteran.

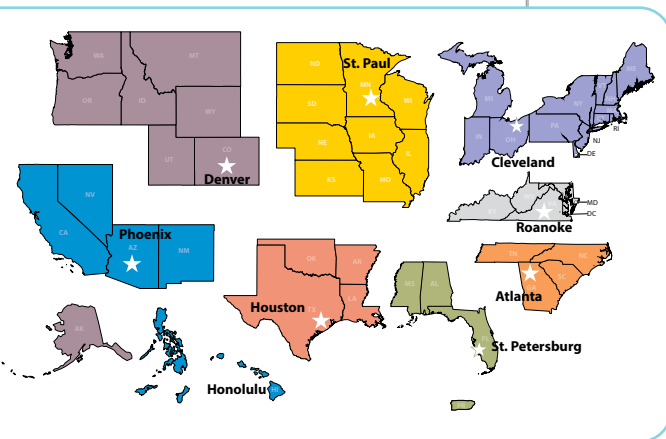
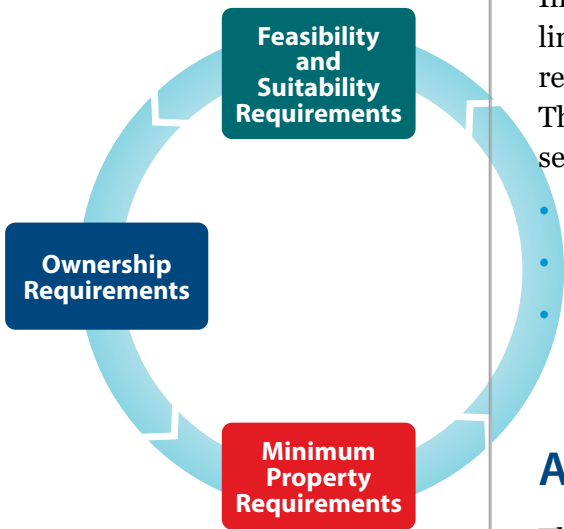

Section 2: Information for Veterans and Service members



Overview

This section provides SAH program information specific to Veterans and Service members. The SAH Agent assigned to each Veteran will provide guidance and assistance in preparing and collecting required documents and exhibits.

NOTES:

How to Apply and Eligibility

Veterans may apply for the Specially Adapted Housing (SAH) and Special Housing Adaptations (SHA) grants by completing VA Form 26-4555, *Veterans Application in Acquiring Specially Adapted Housing or Special Home Adaptation Grant*, and submitting it to their local VA Regional Loan Center (RLC).

However, Veterans are encouraged to apply online at <https://www.ebenefits.va.gov>. eBenefits is a central, web-based portal for Veterans and their families to access, research, and manage their benefits and personal information. To apply, simply visit the eBenefits website, register, and submit an application for SAH benefits.

Once an application is received, the Veterans Service Center (VSC) of jurisdiction will process the claim to determine entitlement for SAH or SHA. It is important to note that entitlement is not determined by the local RLC and SAH Agents cannot answer questions related to claims processing. If entitlement is established, Veterans will receive notification from their local VSC and will also be contacted by their assigned SAH Agent.

Some Veterans, who have not yet applied for the SAH or SHA benefit, may receive entitlement as a result of an inferred issue. In these cases, the Veteran did not specifically apply for the SAH or SHA benefit, but entitlement was “inferred” because the Veteran met the qualifying disability criteria. Veterans receiving entitlement in this manner will receive notification from their local VSC and will also be contacted by their assigned SAH Agent. At this time, Veterans will be asked to complete VA Form 26-4555, *Veterans Application in Acquiring Specially Adapted Housing or Special Home Adaptation Grant*.

Eligibility for the SAH and SHA grants is established once a rating decision establishing entitlement is created and VA Form 26-4555, *Veterans Application in Acquiring Specially Adapted Housing or Special Home Adaptation Grant*, is completed.

indicating that it will be medically feasible for the Veteran to reside in the home after adaptations have been made. If it is not possible for the Veteran to live in the adapted home, either alone or with a caregiver, then the medical feasibility requirements have not been met and the grant cannot proceed.

Financial Feasibility

It must be financially feasible for the Veteran to reside in the home to be adapted and this is determined by assessing whether the Veteran's present and anticipated income are sufficient to pay for the expenses associated with owning and maintaining the home. The purpose of establishing financial feasibility is to protect the Veteran. Specifically, VA wants to ensure the Veteran is able to afford the home on which the grant benefit will be used.

To determine financial feasibility, the SAH Agent will ask the Veteran to complete VA Form 26-4555c, *Veteran's Supplemental Application for Assistance in Acquiring Specially Adapted Housing*. Upon review of the information collected on this form, the SAH Agent will determine if financial feasibility has, or has not, been met.

Important: Information collected on VA Form 26-4555c, *Veteran's Supplemental Application for Assistance in Acquiring Specially Adapted Housing*, is self-reported by the Veteran and does not ask about certain adverse conditions such as bankruptcies, liens/judgements, mortgage delinquencies, or potential foreclosure. It is important for Veterans to know that adverse conditions such as these could have a negative impact on continued ownership of their home. Veterans who are at risk of losing their home should consider this when deciding whether or not to use such a substantial benefit because the SAH and SHA grants cannot be restored.

Property Suitability

It must be determined that the nature and condition of the proposed housing unit is such as to be suitable to the Veteran's needs for dwelling purposes. What this means is that the home must be suitable for adaptation and will meet VA's MPRs once the proposed adaptations are complete. To make this determination, the SAH Agent will inspect the home (or vacant lot), take measurements, and also inspect the site on which the home is situated. This is a good opportunity for Veterans to discuss MPRs, other needed adaptations, and the feasibility of installing such adaptations with the SAH Agent. It is important for the Veteran to consider both current and future needs. MPRs are discussed in detail in Section 5 of this pamphlet.

Conditional Approval

Conditional approval is a status based only upon the SAH program's feasibility and suitability requirements, and prior use. It is important to note that conditional approval is not final grant approval or an authorization for construction to commence. Conditional approval is a necessary step in obtaining final grant approval, the details of which are provided in the next section.

For SAH eligible Veterans, the following is required to reach conditional approval:

- It must be determined that the Veteran has not exceeded the use or dollar limitations for the SAH grant.
- Medical feasibility must be determined.
- Financial feasibility must be determined.
- Property suitability must be determined.

For SHA eligible Veterans, the following is required to reach conditional approval:

- It must be determined that the Veteran has not exceeded the use or dollar limitations for the SHA grant.
- The Veteran must certify in writing that he or she resides, and reasonably intends to continue to reside, in the home to be adapted.

If it has been determined that feasibility and suitability requirements have been satisfied, and the Veteran has not exceeded the usage or dollar limitations of the program, then the Veteran has satisfied the criteria for conditional approval. Once the Veteran has conditional approval for his or her grant, the Secretary can authorize the Veteran to incur certain pre-construction costs, such as:

- architectural services employed for preparation of plans and specifications;
- land surveys;
- attorneys' and other legal fees; or
- other costs or fees necessary to plan for SAH or SHA grant use, as determined by the Secretary.

Important: While conditional approval allows the Veteran to incur pre-construction costs, reimbursement for these costs cannot be provided until after final grant approval. Conditional approval cannot be used to pay for construction plans or any other pre-construction costs in advance. Conditional approval status becomes relevant if pre-construction costs are incurred, but the grant process is terminated for any reason, including the death of the Veteran. In this scenario, the VA may authorize the Veteran, or spouse, to be reimbursed for approved pre-construction costs not to exceed 20 percent of the maximum amount of grant funds available. If the Veteran is continuing with the grant approval process, pre-construction costs may be reimbursed after final grant approval, assuming there are sufficient grant funds to pay for construction costs and pre-construction costs. The Veteran may not incur construction costs prior to grant approval and they are not reimbursable.

NOTES:

detailed in Section 3 of this pamphlet. MPRs and (RAs) are detailed in Sections 5, 6, and 7 of this pamphlet.

Proposed Adaptations and Waivers

In order for a Veteran to obtain final grant approval, the VA must determine that the plans and specifications for the proposed adaptations demonstrate compliance with the minimum property requirements of the SAH program. The SAH Agent will review all final construction documents for SAH grants to ensure compliance is demonstrated. For detailed information regarding SAH MPRs and RAs, please refer to Sections 5 and 6 of this pamphlet. There are no MPRs for SHA grants. However, RAs for SHA grants are provided in Section 7 of this pamphlet.

In some cases, the physical characteristics of a property may make it impossible to incorporate a particular MPR or the Veteran's condition may render a specific MPR unnecessary. In these rare instances, the Veteran may request a waiver for a specific MPR. An MPR waiver request must be in writing and in the Veteran's own words. The request can be typed or handwritten, but it must be legible. The request must be signed by the Veteran or his or her legal representative. The request must provide justification and support as to why the MPR should be waived. For example, the Veteran should be able to explain why the elimination of a particular MPR would provide a greater benefit to him or her than its inclusion. Moreover, MPR waivers should be based on feasibility and need, not personal preference.

Adherence to MPRs is excused when the Veteran's MPR request is approved by the RLC.

Other Documents Required for Grant Approval

The process for grant approval described above covers most SAH, SHA, and TRA grants. However, there are certain situations that may require further documentation and the assigned SAH Agent can advise the Veteran on this subject. Common scenarios that require additional documentation are:

- **Excessive project cost:** When the cost of the project exceeds the amount of available grant funds, the Veteran will be required to provide proof of liquid assets sufficient enough to pay for the additional cost.

Section 3: Information for Builders and Architects/Designers

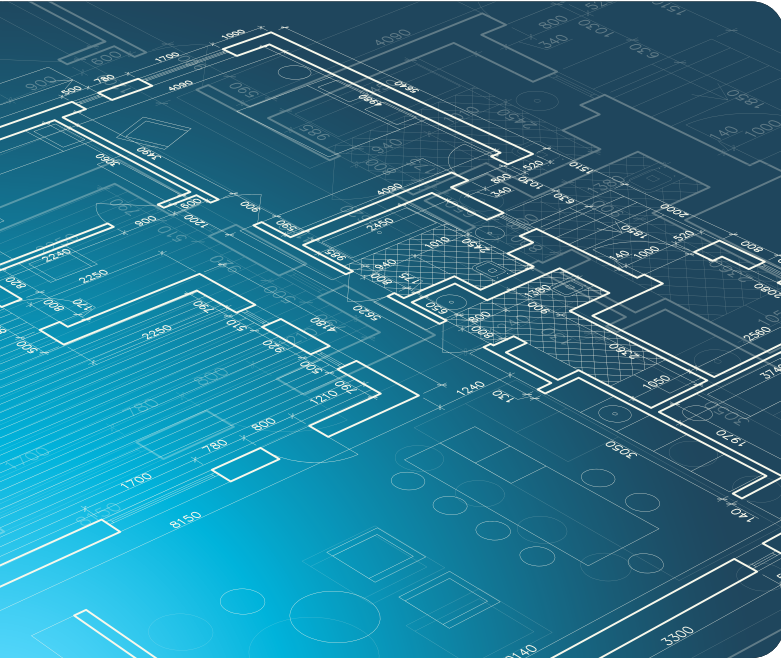

Overview

Builders, architects, and designers are critical to the success of the SAH program and help to ensure disabled Veterans are provided a barrier-free living environment that affords them a level of independent living they may not otherwise enjoy. Program requirements specific to the Veteran were provided in Section 2 of this pamphlet. It is recommended that all program participants read Section 2 so they are familiar with the grant approval process. Information provided in this section will assist VA's external stakeholders in preparing and providing documents necessary for grant approval.

Project Development

In order to reach final grant approval, the contract, plans, and specifications for the proposed project must demonstrate compliance with the MPRs of the SAH program. It is important to note that the Veteran, or his/her legal representative, will engage the services of the selected construction professionals. Even though VA provides guidance to the Veteran and consults builders, architects, and designers on the grant approval process, VA is not a party to the construction agreement. VA is, however, the final approving authority of all SAH, SHA, and TRA grants and construction may not begin until final grant approval and authorization has been given by the RLC of jurisdiction.

To ensure compliance and that the project will adhere to the statutory purpose of the grant, VA relies on the contract, plans, and specifications provided by the builder. Requirements specific to these documents as well as builder, architect, and designer responsibility follow.

A. Contracts

The contract is the legal agreement between the Veteran and the builder. Although the contract is negotiated between the Veteran and builder, VA does have certain requirements. The builder must provide a fixed-price contract that includes the following components:

- the parties to the contract and specified roles, along with signatures of all parties and the dates of signatures;
- the address of the subject property;
- a reference to specific plans and specifications;
- the terms and cost of the project;
- a scope of work;
- a Central Office (CO) approved escape clause; and
- the estimated time to complete the project.

In order to ensure that the Veteran and builder are in total agreement regarding the proposal as a whole, the contract must incorporate by reference, the final signed and dated version of the plans and specifications approved by VA. It is sufficient to reference the plans and specifications by date or version number, so long as it is clearly visible on the documents. After final grant approval, any changes to the elements specified in the original contract must be accompanied by a change order, signed by all parties, and is subject to VA approval.



Scope of Work

The format of the scope of work can be determined by the builder, but the scope of work is considered part of the contractual agreement between the Veteran and builder. The scope of work does not need to include the make and model of finishes, but it must:

- contain a clear description of proposed adaptations, separated by location within the home; and
- be consistent with all contractual documents submitted.

Escape Clause

The contract must include an escape clause with the following statement, exactly as shown below:

“This contract is conditioned in its entirety upon the Veteran receiving a grant under Title 38 U.S.C. Chapter 21 and if this Veteran does not receive this grant, this contract is null and void and any and all monies will be returned without exception.”

Contract Addendums

It is preferred that all contract components described above be incorporated into the contract drafted by the builder. However, the builder may use a contract addendum to address any omissions or changes prior to grant approval. If a contract addendum is used, it must be signed and dated by the builder and the Veteran.

B. Plans and Specifications

Plans and specifications are critical to the grant approval process, as they illustrate the proposed adaptations and provide a detailed list of the materials that will be used for construction. Construction plans must be provided for new construction and remodeling projects, although the exhibits and level of detail of the construction plans depend upon the scope of the project being completed.

Type of Plan	Required for:
Plot Plan	New construction and remodeling projects that include an addition.
Foundation Plan	New construction and remodeling projects that include an addition.
Wall Detail	New construction and remodeling projects that include an addition.
Floor Plans	New construction and all remodeling projects.
Exterior Elevations	New construction and remodeling projects that include an addition.
Interior Elevations	New construction and all remodeling projects.

When plans are required, they will be reviewed for MPR compliance prior to final grant approval. The selected builder is responsible for drafting (either personally or through the use of an architect or draftsman) and submitting the plans to the RLC for approval. This cost can be itemized in the cost breakdown and may be included in the first construction draw.

In order to ensure that the Veteran and builder are in total agreement regarding the plans, the final version of the plans must be signed and dated by the Veteran and builder. In most cases, it is not necessary for the Veteran and builder to sign and date every page. For example, if the dated plans are a cohesive set it is acceptable for the Veteran and builder to sign one page, preferably the first page or title page. However, pages revised after the date of the Veteran's signature must be signed and dated by the Veteran and builder. Plans that are not submitted as a set must be signed and dated by the Veteran and builder on every page.

Plot Plans

For new construction projects, a plot plan is required and must illustrate the following items:

- the proposed housing unit;
- ramps, walkways, and driveways;
- detached garages, carports, outbuildings, and/or other improvements;
- drainage and significant changes in topography;
- critical easements and setback requirements, if applicable; and
- well and/or septic systems, if applicable.

For new construction projects, the plot plan should also indicate the finished grade elevations at the foundation, proposed finished floor height, and the four corners of the site. If the site is large, grade elevations of the site should be identified 30 feet from the corners of the foundation.

For remodeling projects that include an addition, the plot plan is required and must include the following:

- the proposed addition;
- walkways and driveways;
- critical easements and setback requirements, if applicable; and
- only those detached garages, carports, outbuildings, and/or other improvements that the Veteran intends to adapt.

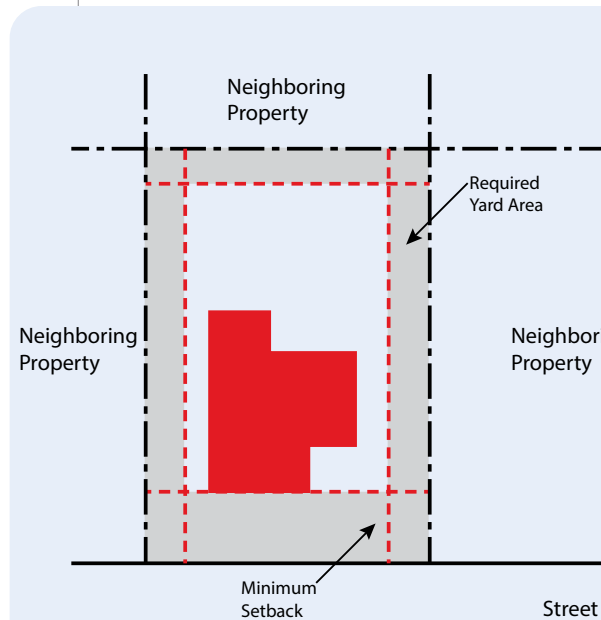
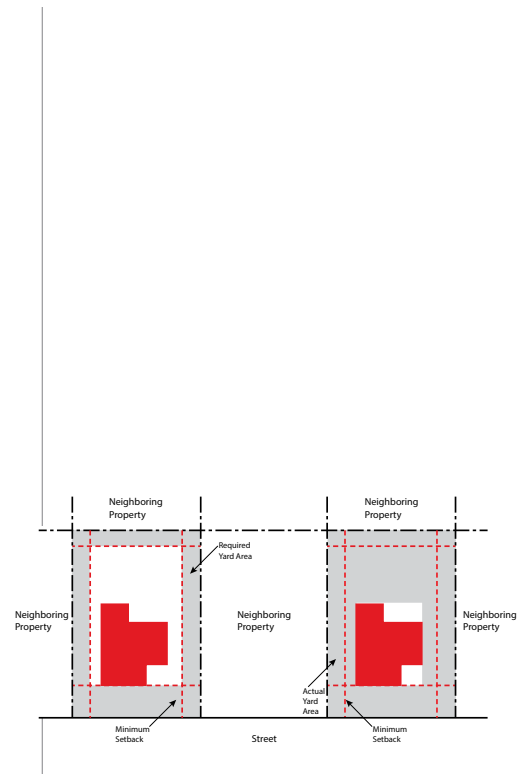

Note: A setback or easement is considered to be critical only if the proposed housing unit or addition is close to encroaching upon it.

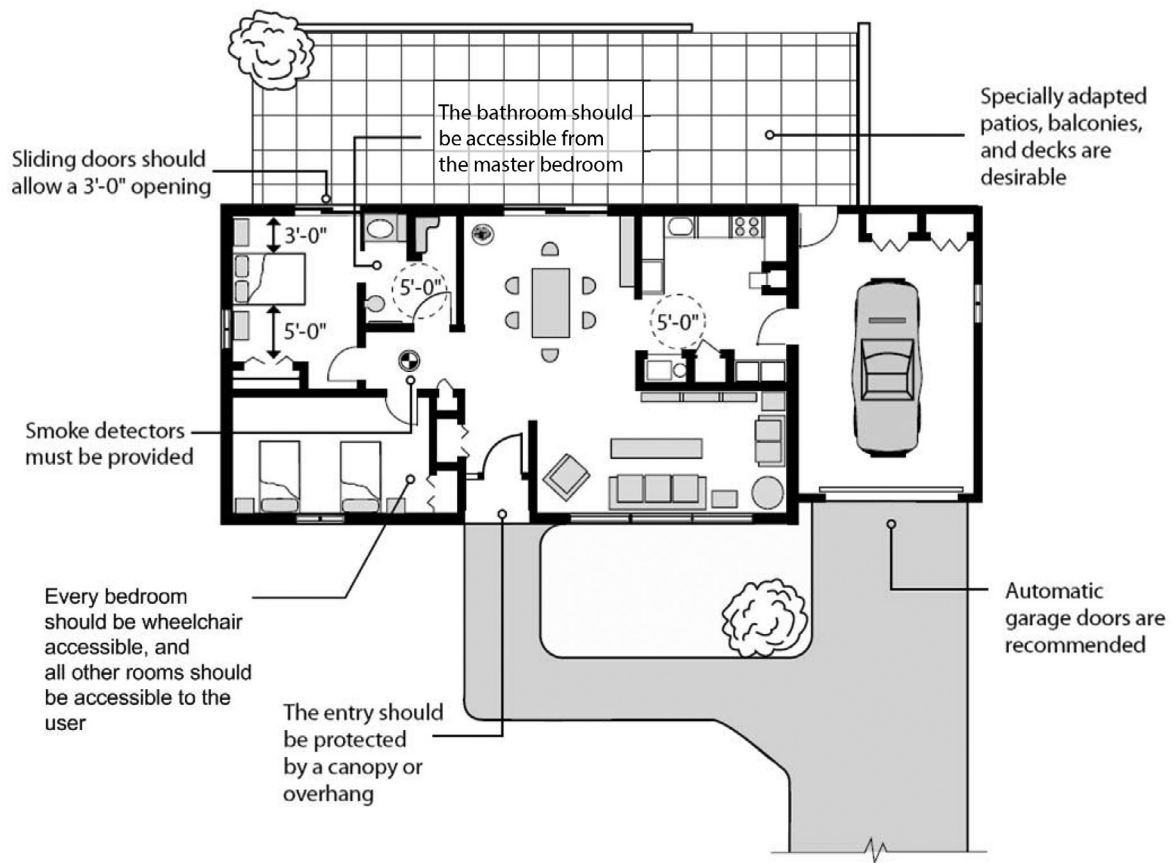

Note: A foundation plan must be notated if the home will be built with a foundation in which the finished floor elevation is flush with the exterior grade or exterior flat work.

Foundation Plans

When a foundation plan is required, it must include the dimensions and materials used for:

- footings,
- walls,
- slab, and/or
- support piers.

Wall Detail

A wall detail is required for new construction and remodeling projects that include an addition. It must illustrate the proposed exterior wall cross section from the foundation/footing upward to the ridgeline of the roof.

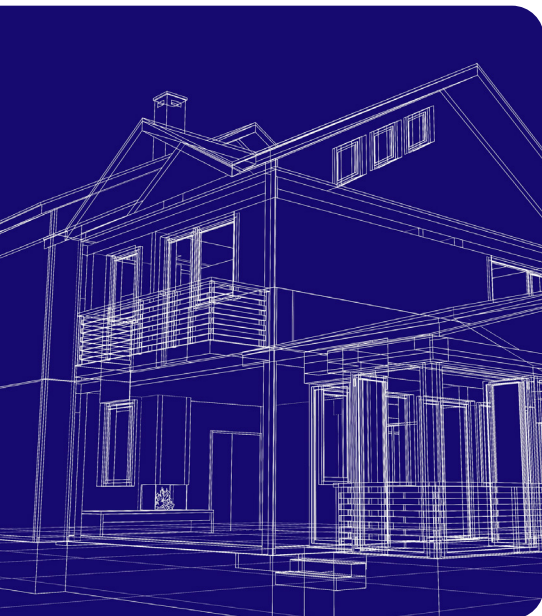

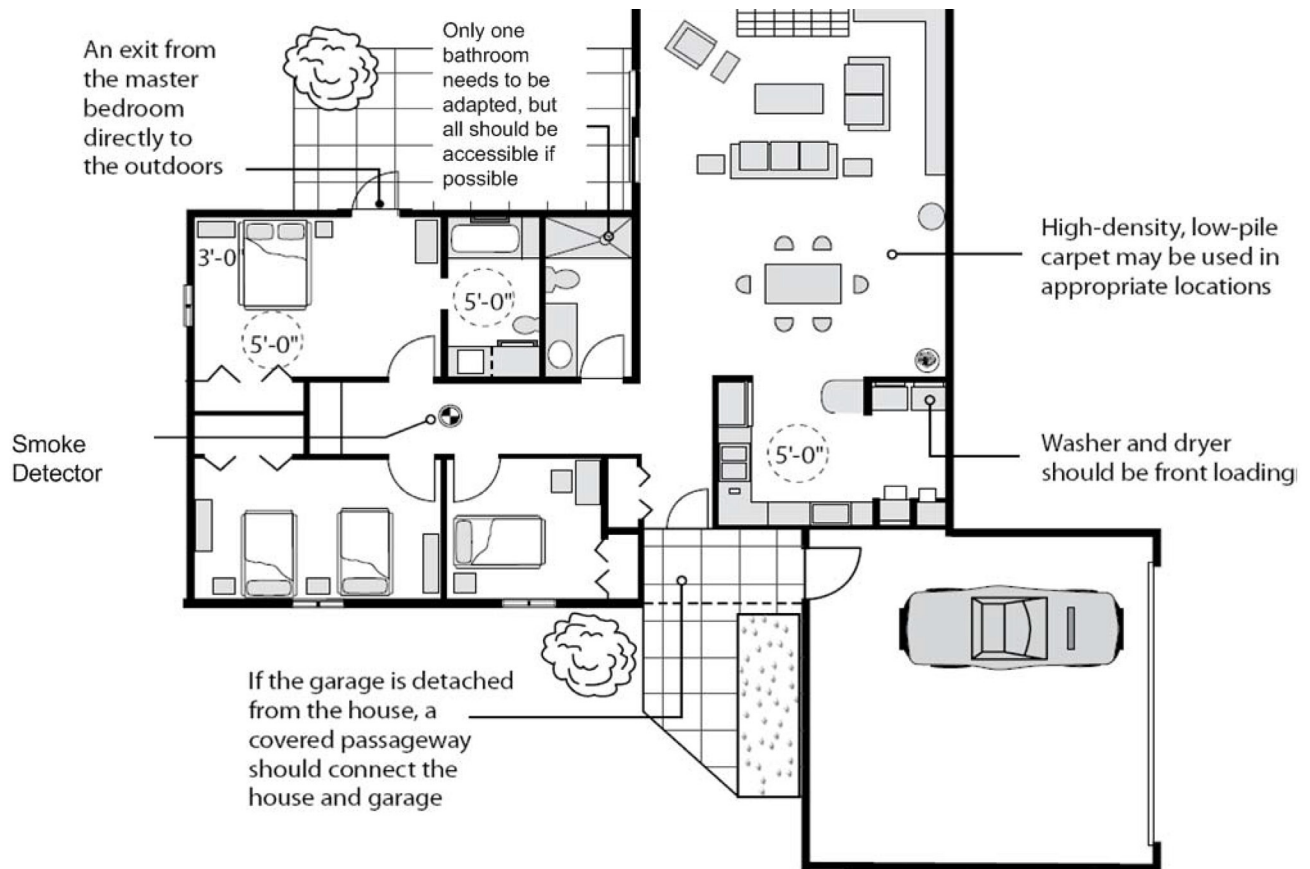

Floor Plans

For new construction projects, a floor plan is required and must illustrate the following:

- all levels, including the dimensions of the home;
- all adapted areas/features and dimensions;
- the garage/carport and dimensions;
- the size and location of interior and exterior doors/windows;
- the dimensions for all rooms, hallways, and passageways; and
- all adapted ingress/egress points including ramps.

For remodeling projects, a floor plan is required and must illustrate the following:

- all adapted areas/features and dimensions;
- the size and location of new interior and exterior doors/windows; and
- all adapted ingress/egress points including ramps.

All plans must also illustrate the location of any special equipment to be installed (e.g., automatic door openers, vertical platform lifts, ceiling track systems, etc.).

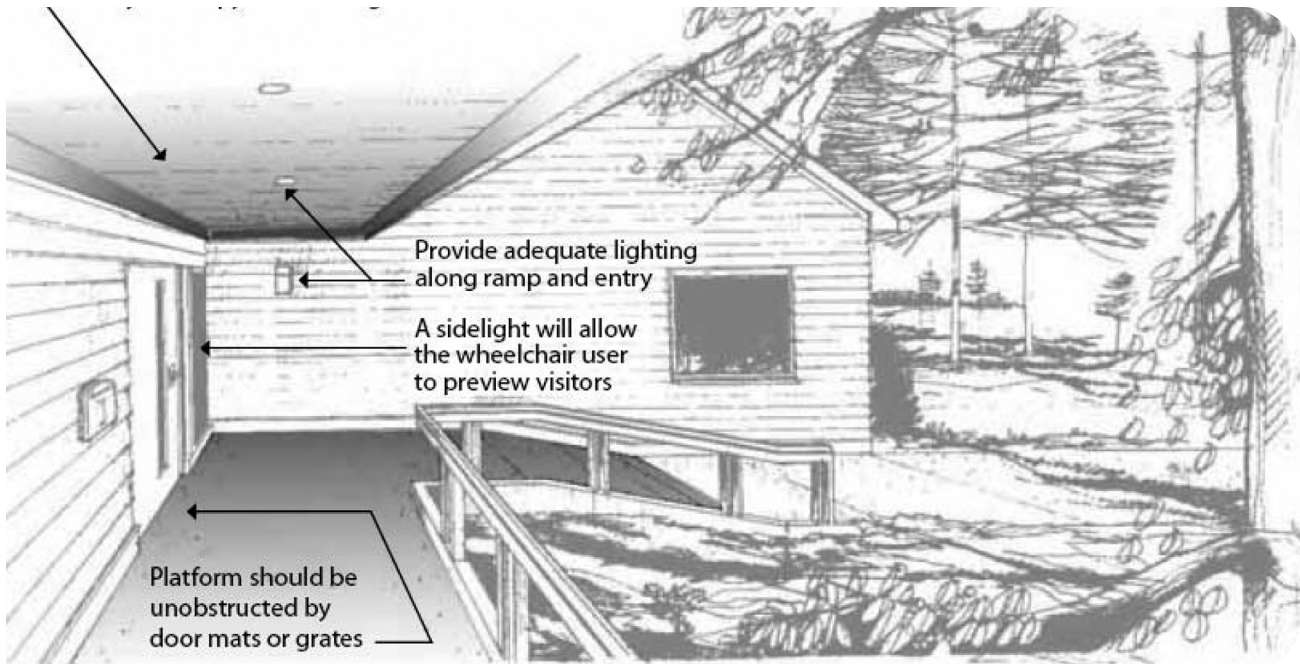

Note: If the proposed project includes ramps, the builder must submit elevations/details that allow the SAH Agent to verify slope, width, and other required features.

Exterior Elevations

Exterior elevations of the housing unit are required for new construction and remodeling projects that include an addition. For new construction, all sides must be shown. For remodeling projects, only the elevations in which the new addition appears are required.

Interior Elevations

For new construction projects, interior elevations are required and must illustrate the following:

- window sill and hardware heights;
- thermostat and electrical outlet, switch, and service panel heights;
- bathrooms adaptations (e.g., all grab bars, plumbing fixtures, bathtub transfer platforms, toilet height, mirror height, cabinets, and roll-under sink);
- kitchen adaptations (e.g., cabinet and counter heights, sink basins, workspaces, and appliance locations); and
- closet/storage area adaptations including the location of closet rods and shelving.

For remodeling projects, interior elevations are only required if any of the items/areas listed above are being replaced/adapted.

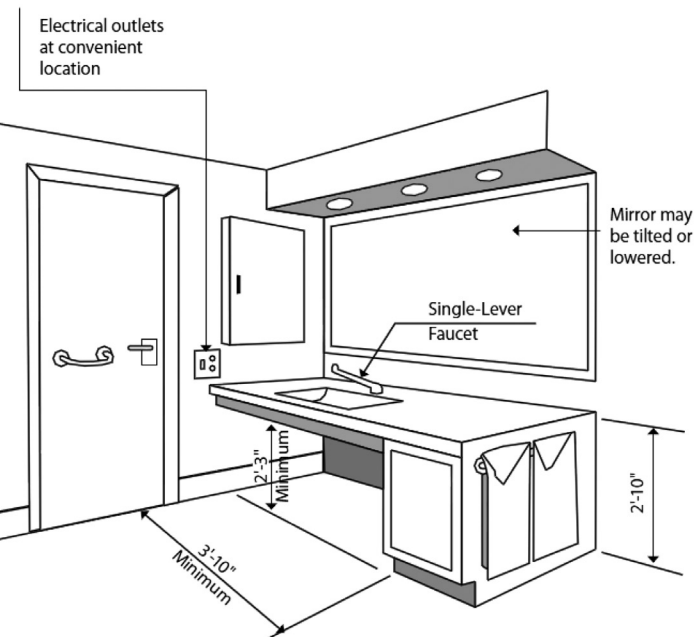

Electrical and Mechanical Plans

Electrical and mechanical plans are not required. However, builders must provide sufficient detail in the contract, scope of work, and/or specifications. Builders may submit electrical and mechanical plans if they deem this to be the most efficient way of communicating the proposed work.

Specifications

The builder must provide a complete list of materials in a format of their choosing. The list of materials must include enough detail so that it may be relied upon for compliance inspections and mediating potential construction disputes. All parties to the contract must sign and date the completed list of materials.

In addition to the list of materials, the builder must supply manufacturer's specification sheets for flooring, appliances, and special equipment. To ensure that all parties are in agreement as to what materials are being used for the project, all parties to the contract must also sign and date the manufacturer's specification sheets. After final grant approval, any changes to the approved list of materials will require a written change order signed by all parties to the contract.

Customer preference items, such as colors and finishes for paint and flooring, are not required for grant approval. In addition, it is acceptable for the builder to provide a budget allowance for lighting and plumbing fixtures rather than specific item descriptions. It should be noted that customer preference items are often the source of construction disputes. In order to reduce the likelihood of a construction dispute, it is advised that the builder obtain and provide proof of customer preference selections.

Builder Certification

The builder must provide a VA builder certification that:

- is signed and dated by a technically qualified and properly identified individual (such as the builder, architect, engineer, etc.); and
- contains the following language, indicating that the home meets code requirements and is free of hazardous material:

“I certify that the construction exhibits for (the property address) meet all local code requirements and are in substantial conformity with both SAH and VA Minimum Property Requirements, and all building standards as required by VA.”

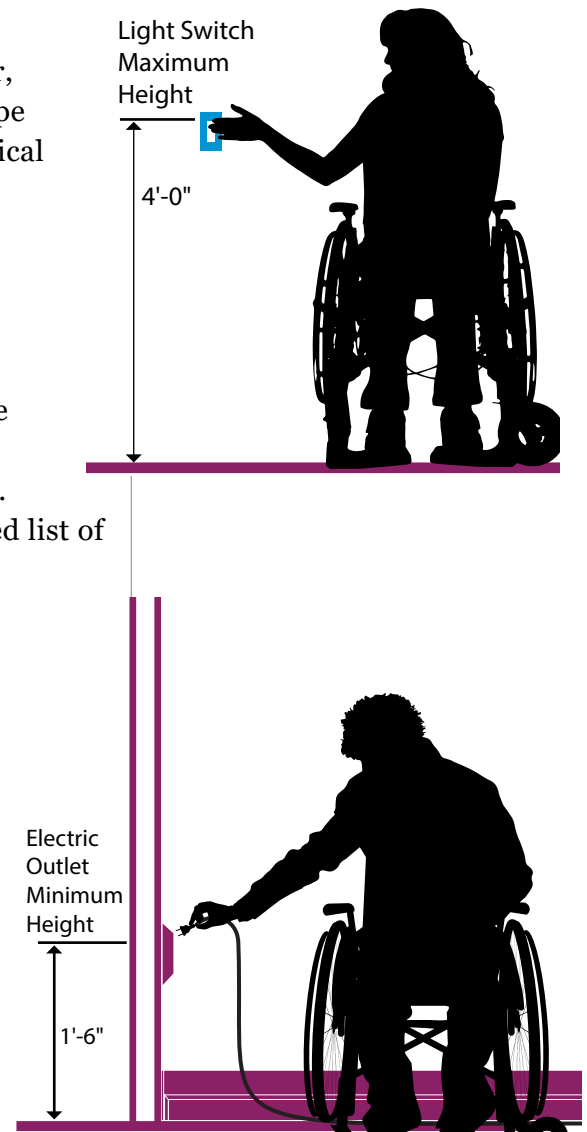

Cost Breakdown

The builder must provide a cost breakdown for all construction and remodeling projects. The cost breakdown is an itemized list of work and associated costs for the construction project and is an integral part of developing the disbursement schedule.

Project Management

Once all construction documents and required information has been submitted and deemed acceptable, the RLC will approve the grant. For most SAH, SHA, and TRA grant projects, grant funds will be placed in an escrow account after grant approval. The grant funds will remain in escrow until the completion and inspection of each stage of construction.

Escrow Accounts

An escrow account is an account where money (grant funds and supplemental funds, such as the Veteran's personal funds and construction loan funds) is put into the custody of a third party. The escrow is to be held by the escrow agent until written authorization is received from the Department of Veterans Affairs (VA) to release the funds.

Disbursement Schedule

The disbursement schedule is created to define the stages of construction and the amount of funds to be disbursed at each stage. Due to VA's unique payment procedure (i.e., funds are not released until the value added work is complete), builders are required to carry the construction cost until the first disbursement. To ensure that builders are aware of this requirement, builders must provide, prior to final grant approval, a detailed disbursement schedule describing the work and associated costs for each stage of construction. This disbursement schedule will be reviewed and approved by the RLC prior to final grant approval.

Note: Every construction project will require twenty percent (20%) of the construction funds to be held in escrow until the project is complete. These funds are payable only after receiving a satisfactory final compliance inspection report and SAH Agent final field review. The compliance inspection and final field review are discussed in more detail in the next section.

Escrow Agreement

The escrow agreement is a legal instrument used to govern the control and release of funds in escrow. This agreement, which will incorporate the approved disbursement schedule, must be signed by the Veteran, builder, and escrow agent prior to depositing funds in the escrow account. Once this document is signed, construction may commence.

Disbursements

Disbursements will be authorized by VA upon the completion of each stage of construction and a satisfactory compliance inspection by the VA compliance inspector. It is important that builders anticipate the need for a compliance inspection and communicate the completion of each stage in a manner that does not create construction delays. Compliance inspection fees are paid by VA; however, if the VA compliance inspector is required to return to the jobsite to re-inspect a particular stage, this fee will be assessed to the builder.



Section 4: VA Compliance Inspectors and Compliance Inspections

Overview

VA Compliance Inspectors (CIs) serve a vital role in the construction of SAH, SHA, and TRA projects and are essential in ensuring that our Veterans receive the adaptations and construction products for which they have contracted.

In order to satisfy the demand for compliance inspections, VA maintains a nationwide panel of well qualified CIs. On rare occasions that a CI is unavailable, or there is limited coverage in a geographic area, VA may rely on RLC staff to complete a compliance inspection. However, because VA relies on the impartiality and expertise of qualified inspectors, it is essential that VA maintain a sufficiently large panel of CIs to provide timely inspections for the hundreds of SAH and SHA grant projects approved across the nation each year. This section of the pamphlet will explain the purpose of compliance inspections, the role of the CI, as well as, the process for completing a compliance inspection.



Purpose of a Compliance Inspection

The purpose of a compliance inspection is to verify compliance of individual construction phases, or turn-key construction, for all SAH, SHA, and TRA grant projects in which grant funds are being disbursed to a builder. A compliance inspection is used to certify that the property has been constructed in accordance with VA-approved plans and specifications, including SAH MPRs and RAs. For more information on VA MPRs and RAs, please refer to the Sections 5 and 6 of this pamphlet.

VA Compliance Inspector Qualifications

To ensure VA is engaging the services of highly qualified inspectors, CI applicants must have:

- at least 3 years of construction related inspection experience;
- a satisfactory Credit Alert Interactive Voice Response System (CAIVRS) screening result; and
- an active inspector license, if required from the state.

In addition to the qualifications listed above, CI applicants must also pass a CI Exam prior to being admitted to the panel. Interested CI applicants should complete [VA Form 26-6681](#), Application for Fee or Roster Personnel Designation, and submit it to the RLC of jurisdiction. [Regional Loan Center Contact Information](#) may be obtained from the Loan Guaranty website.

Assignment of Work

Once assigned to the fee panel, VA CIs will receive requests for inspections on an as-needed basis. As SAH, SHA, or TRA construction projects are approved, compliance inspection assignments are made based on CI availability and geographic proximity. A compliance inspection assignment is officially created once the CI has received an assignment letter from RLC



staff, usually the SAH Agent. CIs will rely on construction documents provided by the SAH Agent to complete the inspections, including:

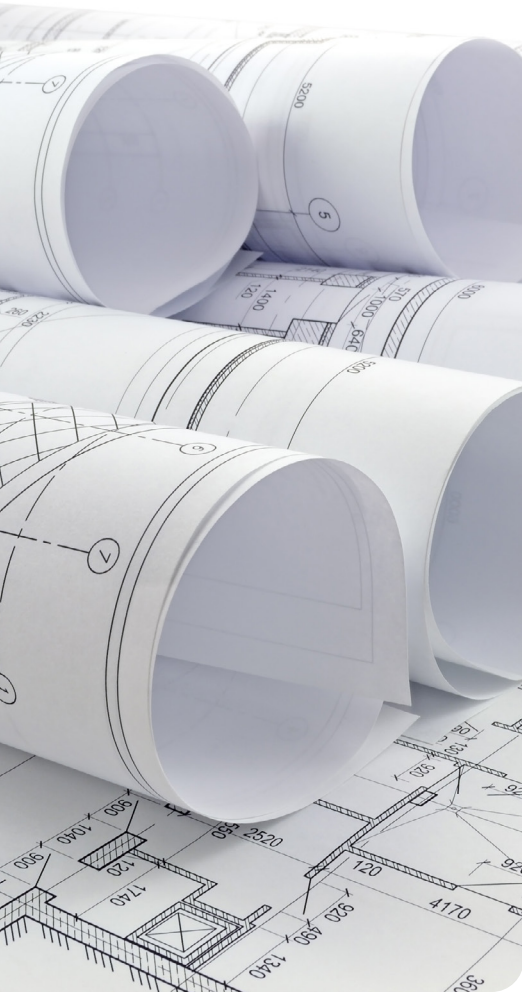

- the VA-approved plans and specifications;
- the VA-approved scope of work, contract, and list of materials;
- MPR waivers;
- the disbursement schedule; and
- if applicable, VA-approved change orders.

The size and scope of each project will determine the number of required inspections. For remodeling projects that require an addition and for new construction projects, the minimum number of inspections is three. Usually, the inspection schedule will match the disbursement schedule and may look something like this:

Inspection 1	Inspection 2	Inspection 3
Foundation/slab is complete and ready for backfill.	Housing unit is enclosed and rough-ins are complete (e.g., electrical, heating, and plumbing).	Housing unit and landscaping are complete.

Prior to accepting the assignment, the CI will be provided with the aforementioned construction documents as well as the inspection schedule.



Completing a Compliance Inspection

VA CIs are expected to review the project documents provided by the SAH Agent prior to the first inspection. If changes to the project have been made, the SAH Agent will provide the CI with a VA-approved change order. At each phase of construction, as determined by the inspection schedule, the CI will inspect the project to certify it has been constructed in accordance with the VA-approved plans and specifications and that there are no deficiencies, deviations, or unauthorized substitutions. The CI must:

- compare the actual work completed to the VA-approved plans and specifications provided by the SAH Agent;
- measure critical dimensions and adapted components to ensure adherence to SAH MPRs and RAs;
- observe the materials used by the builder to ensure consistency with the list of materials;
- provide digital photographs for each inspection of the areas affected by the construction; and
- report the specific stage of construction and whether or not the work for that specific stage of construction is complete and compliant, or advise if a re-inspection of non-compliant items is required.

The CI should verify permits for each construction stage as it is inspected. It is important to note that the CI is not a building code inspector and the compliance inspections are limited to the scope described above. However, if the CI notices items that could cause an issue during a building code inspection, he or she should inform the SAH Agent and builder.

Reporting a Compliance Inspection

The compliance inspection is reported using [VA Form 26-1839](#), Compliance Inspection Report (CIR). The CIR may be completed manually by printing a copy of the form, completing all appropriate fields, and submitting the completed form to the SAH Agent. Or, it may be submitted electronically using SAHSHA, the software application VA uses to manage the SAH program. Active CI panel members will be provided instructions to establish a user account to this system upon request.



Section 5: SAH Minimum Property Requirements

Smoke detectors must be provided

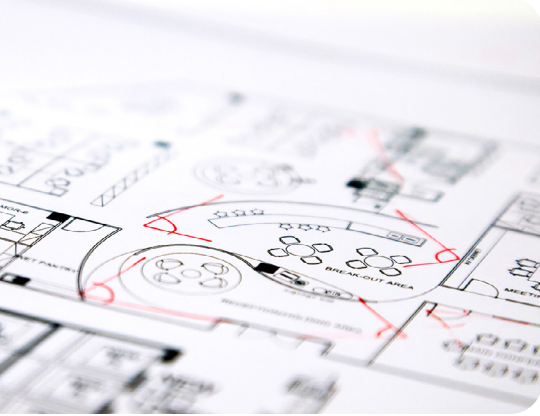

Overview

MPRs are absolute conditions specified under governing law for the SAH grant. Title 38, United States Code, Chapter 21 and 38 Code of Federal Regulations (CFR), 36.4401 through 36.4410 mandates that any housing unit acquired, constructed, or remodeled using proceeds from the SAH grant program must:

- comply with the MPRs, and
- include features necessary to accommodate the Veteran's disabilities.

To increase flexibility in the program requirements and focus on areas that are deemed most critical, VA has established MPRs for only three areas:

- points of ingress and egress,
- primary bathroom, and
- primary bedroom/sleeping area.



Adherence to MPRs may be waived when compliance is not feasible and/or the Veteran requests an MPR waiver that is approved by the RLC. In some instances, the nature of a Veteran's condition may obviate the necessity for a specific MPR. In these limited situations, the RLC may approve an MPR waiver request from the Veteran. There is a need for flexibility and the exercise of judgment based on the physical abilities and limitations of each Veteran. However, MPRs are limited to only three areas and waivers should be the exception, not the norm. Moreover, MPR waivers are based on feasibility and need, not personal preference. The following examples illustrate acceptable and unacceptable reasons for waiving an MPR:

Example 1 (Need): A Veteran, who is in the advanced stages of ALS, is primarily bedridden and is unable to use some of the adapted features normally included in an adapted bathroom. In fact, the only adapted feature the Veteran would be able to use is a roll-in shower and this will be done with the assistance of a caregiver. In order to gain access to the shower, the Veteran would still require an accessible floor area and 36-inch wide entry door. In this situation, there is no need to adapt the sink and toilet, so the Veteran, or his POA may request a waiver for these features.

Example 2 (Feasibility): A Veteran and builder are in the final planning stages of a construction project and it has been determined that all of the MPRs will be met except for the Veteran's bedroom door. Because the hallway leading to the bedroom is 38 inches wide and both of the hallway walls are load bearing, it is not feasible to widen the hallway or provide a 36-inch wide door. Because it is not feasible, or possible, to widen the hallway in order to accommodate a 36-inch wide door, the Veteran may request a waiver of this MPR.

Example 3 (Want): An elderly Veteran who ambulates well using braces and prosthetics has requested a waiver of all bathroom MPRs because he does not want them. Instead, the Veteran would rather use the remaining grant funds to reduce the principal balance of his mortgage. In this situation, it is not acceptable to waive the bathroom or other major MPRs simply because the Veteran does not want them. As indicated earlier in this section, MPR waivers should be based on need, not want. The Veteran must be able to explain why the elimination of a particular MPR would provide a greater benefit than its inclusion. Moreover, it is important to consider that this elderly Veteran's condition may decline in the future and his ability to ambulate using braces and prosthetics may diminish, thereby increasing his dependence on the adapted bathroom features.

This last example illustrates the importance of not only considering the Veteran's current condition but anticipating changes in his or her condition that would increase their dependence on adapted features. Another consideration is the inclusion of adapted features that will assist the caregiver in providing care to the Veteran.

Ingress and Egress Requirements

An adapted housing unit must have a minimum of two ingress and egress points that satisfy the MPRs presented in this section. The location and types of ingress and egress points are determined by the topography, floor plan, and Veteran preference. However, at a minimum, the two ingress and egress points must:

- provide a proximate means of emergency egress from the primary, adapted bedroom/sleeping area, and
- be located at different locations within the house.

It is preferable that the emergency egress location be directly off the primary, adapted bedroom/sleeping area. If this is not possible, the emergency egress must be proximate to the primary, adapted bedroom/sleeping area. It must also be free of potential fire hazards and not pass through, or originate in, an area prone to potential fire hazards such as the kitchen, garage, utility room, or any room containing a heat source. Additional instructions regarding bedroom window egress requirements are provided later in this section.

All doorways that are adapted ingress and egress routes must:

- have a minimum width of 36 inches, and
- have a beveled threshold with a maximum height of 1/2 inch.

There are several types of ingresses and egresses that satisfy MPRs. They may be used interchangeably:

- no-step entry,
- vertical platform lift (VPL),
- elevator, or
- ramp or walkway.

No-Step Entry

A no-step entry may be sufficient when topography and grading eliminate the need for a ramp, lift or elevator (e.g., a housing unit built on slab). The no-step entry must meet the doorway and entrance requirements discussed earlier in this section. For entries in which the difference between the exterior grade/elevation and the interior/finished floor elevation is less than 4 inches, a transition is acceptable

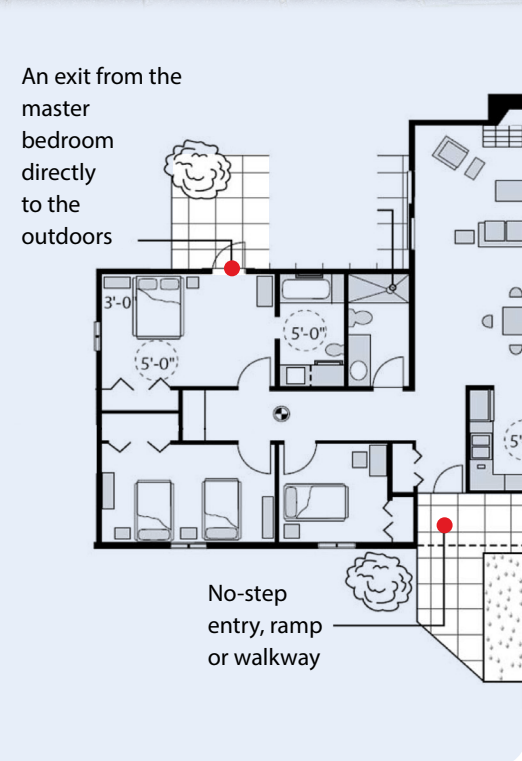

and a 5-foot by 5-foot platform accompanied by a ramp is unnecessary. The transition must:

- be immobile,
- be constructed of a durable material other than wood,
- provide unimpeded ingress/egress, and
- complement the Veteran's condition and choice of wheelchair.

Vertical Platform Lift

A VPL is a mechanical device capable of providing a vertical means of ingress and egress in locations where ramps are not feasible due to topography or space constraints. The weight capacity and lift height vary by model and manufacturer; however, a VPL must:

- have a platform with a minimum usable width of 36 inches by 48 inches, and
- be connected to a continuous power source such as a generator or battery back-up.

Elevators

Elevators, either internal or external, are also capable of providing a vertical means of ingress/egress. An elevator must have the following:

- a car with minimum interior dimensions of 48 inches by 48 inches,
- a 36-inch wide entry door/opening,
- a connection to a continuous power source such as a generator or battery back-up, and
- be equipped with a land line telephone to communicate with emergency personnel in case of entrapment caused by a power outage or mechanical failure.

Ramps and Walkways

Ramps and walkways should be constructed of concrete, masonry, wood, metal, or composite materials and must:

- be permanently installed;
- have a minimum width of 42 inches (existing) or 48 inches (new); and
- be constructed in a manner that prevents slipping in wet or icy conditions (e.g., broom finish for concrete surfaces, 1/4 inch spacing between deck boards, metal grating, or built-in heating coils).

Note: The Veteran should notify local emergency personnel, if applicable, of his/her dependence on an elevator as a means of ingress/egress. This is an added safety measure in the event of complete power/mechanical failure and loss of telephone connectivity.

Note: For ramps or walkways that are more than 4 inches above grade and that cannot be constructed in a way to eliminate accidental falling, a low curb or guardrail, on both sides, with a minimum height of 5 inches is required. This requirement can usually be avoided by backfilling soil along the walkway to provide a reasonably level transition between the walkway and adjacent soil.

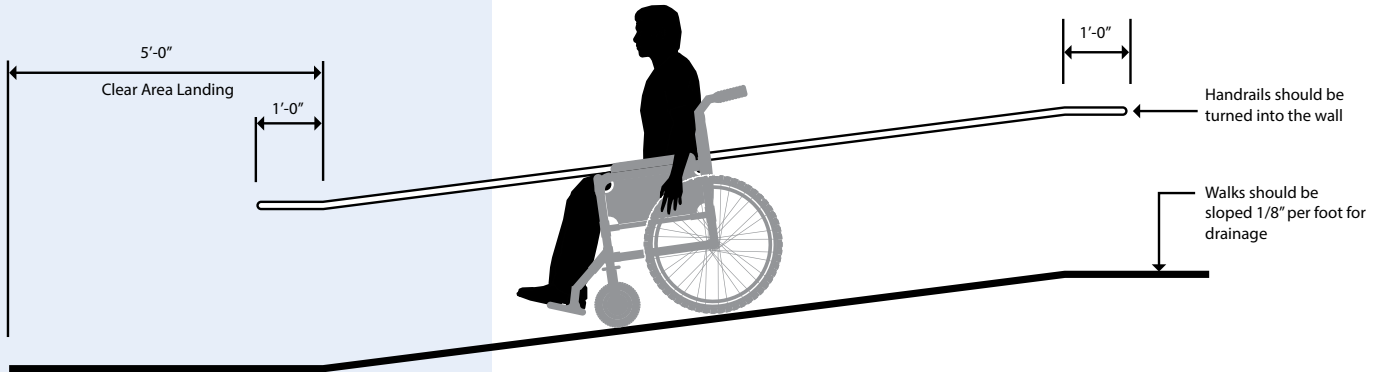

Important: It is acceptable to use an existing modular ramp provided by Prosthetics and Sensory Aids as one of the approved ingress and egress points, as long as the condition of the ramp is deemed safe by the SAH Agent. However, new modular ramps must be permanently installed and meet the MPRs discussed in this section.

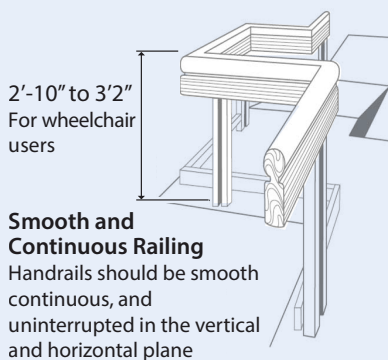
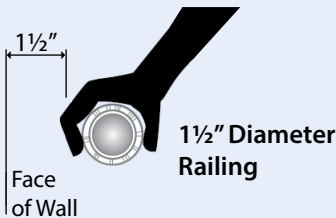

Ramps and walkways must also have:

- A slope of eight percent or less (i.e., for every 1 inch of rise there is 12.5 inches of run or more)
- A handrail that meets the following criteria:
 - installed at a height convenient to the Veteran,
 - minimum diameter of 1½ inches,
 - clearance from mounting surface of 1½ inches to 2 inches,
 - smooth continuous surface, and
 - installed on both sides of the ramp with a minimum of 42 inches of clearance between handrails.
- A platform that meets the following criteria:
 - located at any wheelchair entrance,
 - provided at every 30 feet or less of continuous ramp,
 - located at turns in the ramp greater than 45 degrees,
 - minimum size of 5 feet by 5 feet unhindered by handrails or gutters,
 - constructed of non-slip materials, and
 - have a reasonably level surface.

If the slope of the ramp/walkway is less than five percent, a handrail is not required. However, the ramp/walkway must have a low curb/guard rail on both sides with a minimum height of 5 inches if the ramp/walkway is more than 4 inches above grade. See the note on page 37 about using backfill to avoid this requirement.

Primary Bathroom Requirements



At a minimum, an adapted housing unit must have one fully adapted bathroom that satisfies the MPRs presented in this section. The primary, adapted bathroom must be in a location that is convenient and accessible for the Veteran. The following features are required in an adapted bathroom:

- roll-in shower,
- accessible sink,
- accessible toilet,
- accessible floor area, and
- 36-inch wide entry door.

Roll-in Shower

The roll-in shower must have the following features:

- minimum interior dimensions of 48 inches x 48 inches,
- a minimum opening of 36 inches,
- non-slip flooring with a coefficient of friction (DCOF) of 0.42 or greater,
- a maximum floor slope of $\frac{1}{4}$ inch to 12 inches (i.e., 1-inch slope from front to rear in a 48-inch deep roll-in shower),
- at least one grab bar per wall placed at a location convenient to the Veteran and capable of supporting the Veteran's weight,
- at least one hand held shower head, and
- accessible, thermostatic or pressure-balance controls to avoid sudden changes in water temperature.

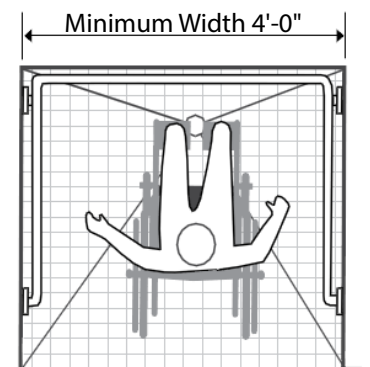
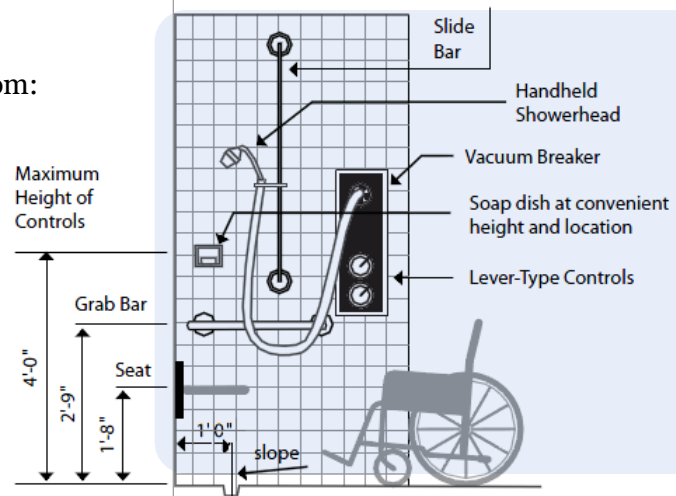

Note: Although only one grab bar is required at the toilet, the Veteran should be encouraged to install as many as needed. The height and type of toilet should be determined by the Veteran.



Accessible Sink

The adapted bathroom must be equipped with at least one roll-under, wall hung, or pedestal sink that is accessible to the Veteran. The width, height, and depth of the sink should be convenient for the Veteran. Any exposed pipes must be wrapped, or covered, in case of accidental contact by the Veteran.

Accessible Toilet

Toilets must have:

- a 48-inch clear front transfer space or a 36-inch clear side transfer space, and
- a minimum of one grab bar installed at a location that is convenient to the Veteran.

Accessible Floor Area

Floor areas must:

- allow at least one clear area for maneuvering with a minimum diameter of 5 feet (the turning area may extend into the roll-in shower), and
- be non-slip in both wet and dry conditions with a DCOF of 0.42 or greater.

Entry Door

Entry doors to the adapted bathroom must:

- have a minimum opening of 36 inches,
- not intrude on the accessible floor area (i.e., doors must swing outward or slide such as, a pocket door), and
- not obstruct wheelchair maneuvering when open.

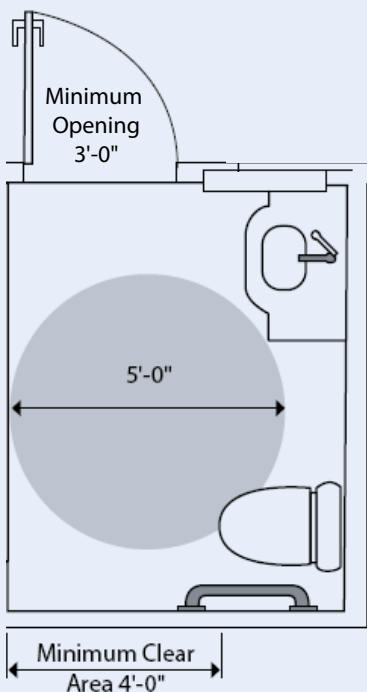

Primary Bedroom/Sleeping Area Requirements

At a minimum, an adapted housing unit must have one adapted bedroom/sleeping area that satisfies the MPRs presented in this section. The following features are required in an adapted bedroom/sleeping area:

- 36-inch wide entry door,
- sufficient space for maneuvering,
- accessible flooring, and
- proximate emergency egress.

Entry Door

Entry doors to the primary adapted bedroom/sleeping area must:

- have a minimum opening of 36 inches, and
- not obstruct wheelchair maneuvering when open.

Sufficient Space for Maneuvering

The primary adapted bedroom/sleeping area must be sufficient enough in size to accommodate furniture while allowing the Veteran freedom of movement.

Accessible Flooring

The flooring type must:

- not impede wheelchair maneuverability, and
- if carpeted, be low pile, closely woven and padded with a durable fiber type.

Proximate Emergency Egress

As previously discussed, the primary adapted bedroom/sleeping area must, whenever possible, be equipped with an emergency egress point. If this is not possible, and the emergency egress point is proximate rather than direct, the primary adapted bedroom/sleeping area must have a window of sufficient size to allow access by emergency personnel. Local building code requirements should be consulted to establish acceptable design parameters.

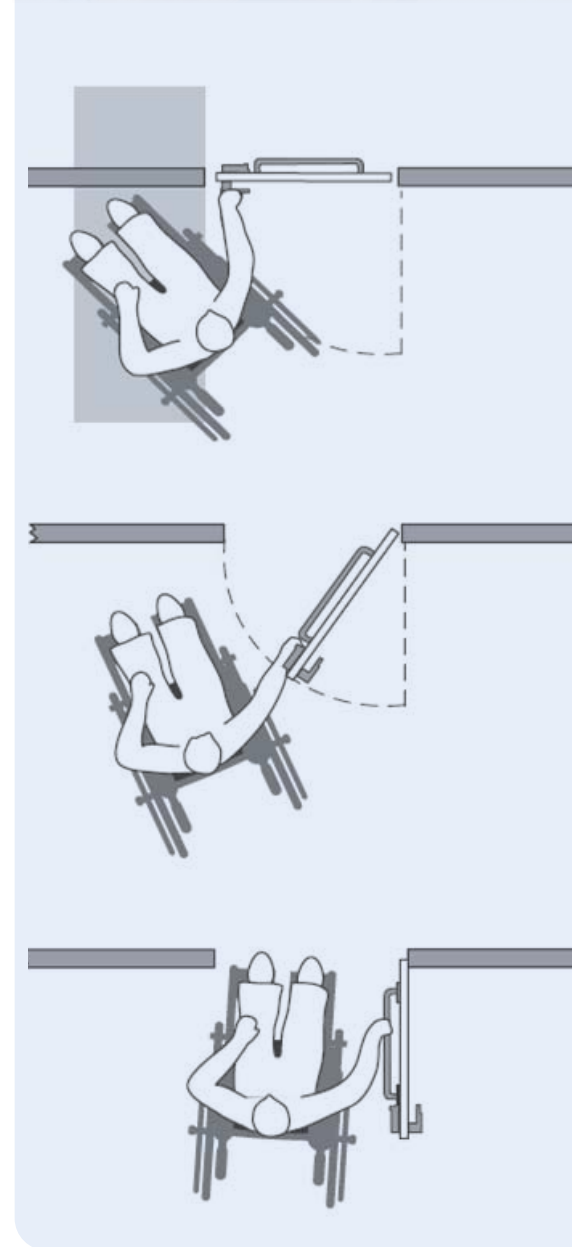



Condominiums and Townhouses

Due to the nature of condominium and townhouse construction, MPRs related to ingress and egress for this type of residence are slightly different than for a detached residence. In addition to convenience and accessible design, it is important to consider evacuation and safety. When possible, Veterans should consider purchasing a townhouse or condominium unit located on the first floor. If this is not possible or the Veteran already owns a unit located above the first floor, the following areas must be addressed:

- ingress and egress,
- windows,
- balconies, and
- emergency access.

Ingress and Egress

At least one suitable means of access must be provided so the Veteran has a level ingress and egress point from the condominium or townhouse. In the absence of a level ingress/egress point, it may be necessary to utilize ramps, platforms, or elevators to eliminate any elevation difference between interior and exterior floor levels. Condominiums or townhouses located above the first floor only require a single SAH MPR compliant exit.

Windows

At least one window must be of sufficient size to allow access by emergency personnel. Local building code requirements should be consulted to establish acceptable design parameters.

Balconies

If purchasing a unit located above the first floor, Veterans should consider purchasing one with a balcony that is accessible to emergency personnel. There is no requirement to construct a balcony on a unit in which a balcony does not exist.

Evacuation and Safety Requirements

For units located above the first floor, the following evacuation and safety features are required:

- The condominium or townhouse unit must be accessible using firefighting and evacuation equipment from the exterior of the unit.
- The location of the Veteran's condominium or townhouse unit must be registered with local emergency personnel.
- No unit may be located beyond the reach of the highest evacuation ladder system available to local emergency personnel. The SAH Agent will verify the capabilities of local emergency personnel servicing the Veteran's property.
- If the Veteran is completely bedridden, the condominium or townhouse unit must contain an externally-mounted device (audible, visible, etc.) which aids emergency personnel in locating the Veteran.
- The Veteran's bedroom window must be of sufficient size to allow access by emergency personnel and have exterior markings to guide emergency personnel.

Other Requirements

Primary bathroom and bedroom/sleeping area MPRs apply to condominiums and townhouses as described in the previous section.



Section 6: SAH Recommended Adaptations



Overview

RAs are suggested modifications above and beyond the MPRs. They are not required to obtain grant approval. RAs were developed over time by SAH program experts who have gained an understanding of the residential needs of Veterans eligible for the SAH grant.

There is a need for flexibility and the exercise of good judgment based on the physical capabilities and limitations of each Veteran. Equally important is the need to anticipate the Veteran's future needs. SAH Agents will assist the Veteran in using a modular approach to adapting the housing unit. That is, RAs should be chosen by the Veteran, on an as needed or as desired basis, once the MPRs have been satisfied.



Because RAs are not required for grant approval, a waiver process is **not** necessary. Nor is it a requirement that every RA be incorporated into the design of each room, or area, being adapted. Veterans have freedom of choice and may select individual features. The specifications provided for each RA in this section are not absolute. However, they should be adhered to when possible as they represent adaptations that have been field tested. VA has flexibility in approving minor variations in the specifications provided in this section and a formal approval process is **not** required. VA will exercise sound judgment in determining which variations are acceptable. If the variation is significant, VA will question whether the proposed work represents an adapted feature.

Although the purpose of creating RAs is to introduce greater flexibility to the SAH grant program, it is important to remember that grant funds can only be used for adaptations that benefit the Veteran. CO may consider exceptions to this rule if it is determined that the proposed adaptations are necessary for the Veteran's caregiver and will improve the Veteran's quality of life. The request must be submitted by the Veteran, along with justification for the adaptation.

The list of RAs is substantial, but not all-inclusive. Therefore, if a Veteran desires an adaptation not included in this section, a request must be submitted by the Veteran, along with justification for the adaptation.

Specifications for Ingress and Egress

Doorways and Hallways

To ensure freedom of movement and convenience throughout an adapted housing unit, the following doorway and hallway specifications are considered reasonable:

- New interior and exterior doorways that are a minimum of 36 inches wide
- Existing interior doorways that are a minimum of 32 inches wide
- Thresholds that are beveled with a maximum height of 1/2 inch
- Provide protection from inclement weather at ingress and egress points using a stoop, canopy, or overhang
- New hallways that are a minimum of 48 inches wide
- Existing hallways that are a minimum 42 inches wide

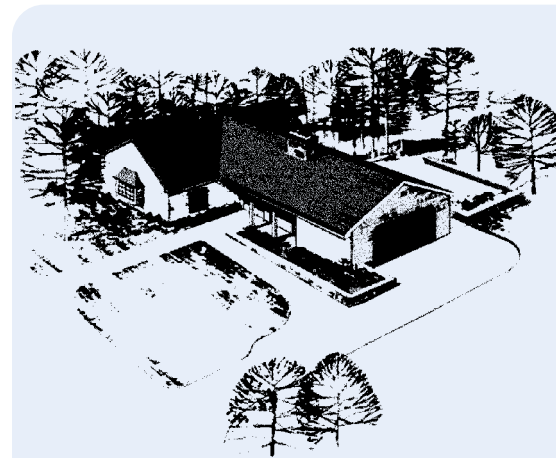

Note: It is important to note that grant funds cannot be used to cure deferred maintenance.

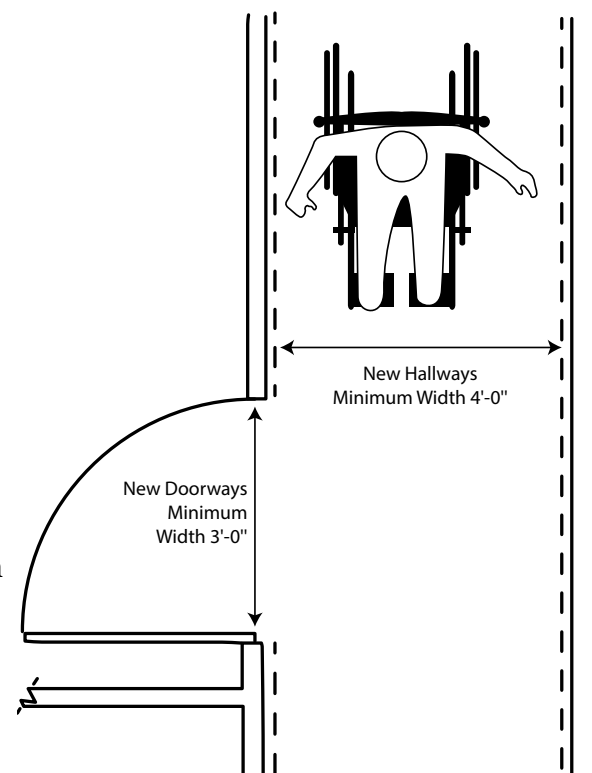

Specifications for Living Quarters

Bathrooms

In addition to the bathroom MPRs contained in Section 5 of this pamphlet, the following adapted features are considered reasonable:

- An accessible medicine cabinet placed at a convenient height
- A mirror placed at a height that provides adequate visibility
- Cabinets with pull-out shelving and/or sliding doors
- Closets with accessible shelving
- Single-lever faucets
- Additional grab bars
- Built-in or folding shower benches
- Comfort height toilets with a bidet seat or a separate bidet unit
- Accessible tubs with:
 - a transfer platform,
 - an accessible, single lever faucet that is thermostatic or pressure-balance controlled to prevent sudden water temperature changes,
 - grab bars in convenient locations, and
 - sufficient clearance to allow for unobstructed access.

Additional Bedrooms

Reasonably necessary bedroom adaptations include:

- One clear area for maneuvering with a minimum diameter of 5 feet
- A minimum 4-foot clear access area in front of the closet
- A clear space of 4 feet between the end of the bed and the opposing wall
- An accessible closet with a minimum 36-inch opening and shelving installed at a height that can be reached from a seated position

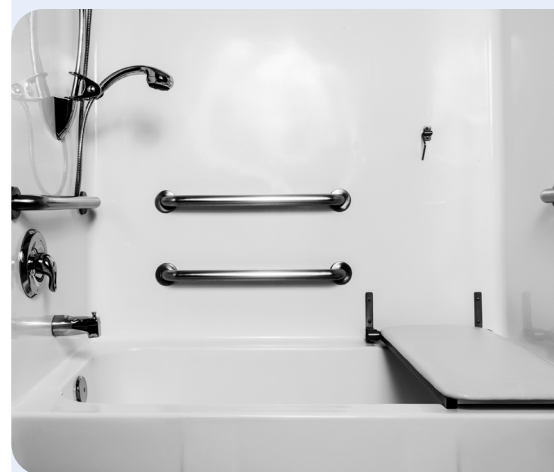



A staggered burner arrangement is preferred

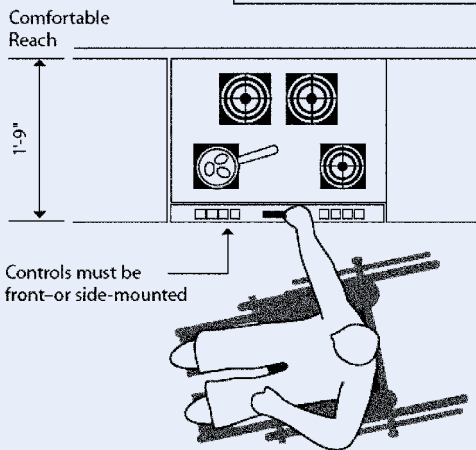

Note: When a new addition is constructed, it is acceptable, within reason, to install maintenance-free materials on the existing home to match the new addition.

Kitchen

The kitchen layout should allow for adequate maneuvering room for the Veteran and have a turning area with a minimum 5-foot diameter. The following kitchen adaptations are considered to be reasonable:

- Roll-under work counter with a width and height that is convenient
- Roll-under sink with a width and height that is convenient
- Single lever faucets
- Accessible cabinets and closets with pull-out shelving and/or sliding doors
- Electrical outlets and switches that are within reach
- Accessible dishwasher
- Side-by-side refrigerator
- Built-in, roll-under cooktop with front control
- Built-in oven installed at a convenient height
- Free standing range with front controls

Maintenance-free Materials

The use of durable, maintenance-free materials is desired. Examples include:

- Vinyl or composite siding
- Clad windows
- Composite exterior doors
- Wood composite for decks and porches

Heating and Air Conditioning

Heating and air conditioning systems should:

- meet or exceed building code requirements;
- be adequate for healthful and comfortable living;
- be designed to meet the Veteran's needs (zoned, individual units, etc.); and
- be equipped with a thermostat or controls that are accessible by the Veteran.

Electrical Equipment

Wall switches and electrical outlets should be located in positions that are unobstructed and at heights that are convenient to the Veteran. Typically, they are located 18 inches (minimum) to 48 inches (maximum) from the floor in an adapted housing unit. Electrical utility boxes should be located so the Veteran has unobstructed access from a wheelchair. Typically, they are located near an egress point with a maximum height of 48 inches to the top breaker. Other utility controls, including appliance controls and garage door openers, should be located in positions that are unobstructed and convenient for the Veteran.

Security and Emergency Equipment

Smoke detectors should be installed according to local building code requirements. Usually, this requires that smoke detectors be installed in the main portion of each living area, on each level of the house, and at the entrance to each bedroom. Other acceptable security and emergency equipment includes:

- alarm systems,
- security cameras,
- intercom systems (excluding whole house audio systems),
- flood lights/security lights with motion sensors,
- privacy fencing,
- carbon monoxide detectors,
- keyless entry,
- automatic door openers/closers,
- fire sprinkler systems, and
- storm shelters installed to local building code requirements.

Windows

Windows should be durable, low maintenance, and energy efficient. They should also:

- be operable from a wheelchair in a seated position;
- have a maximum sill height of 2 feet 9 inches;
- be located so the Veteran has maximum visibility; and
- have locks that are operable from a wheelchair in a seated position.

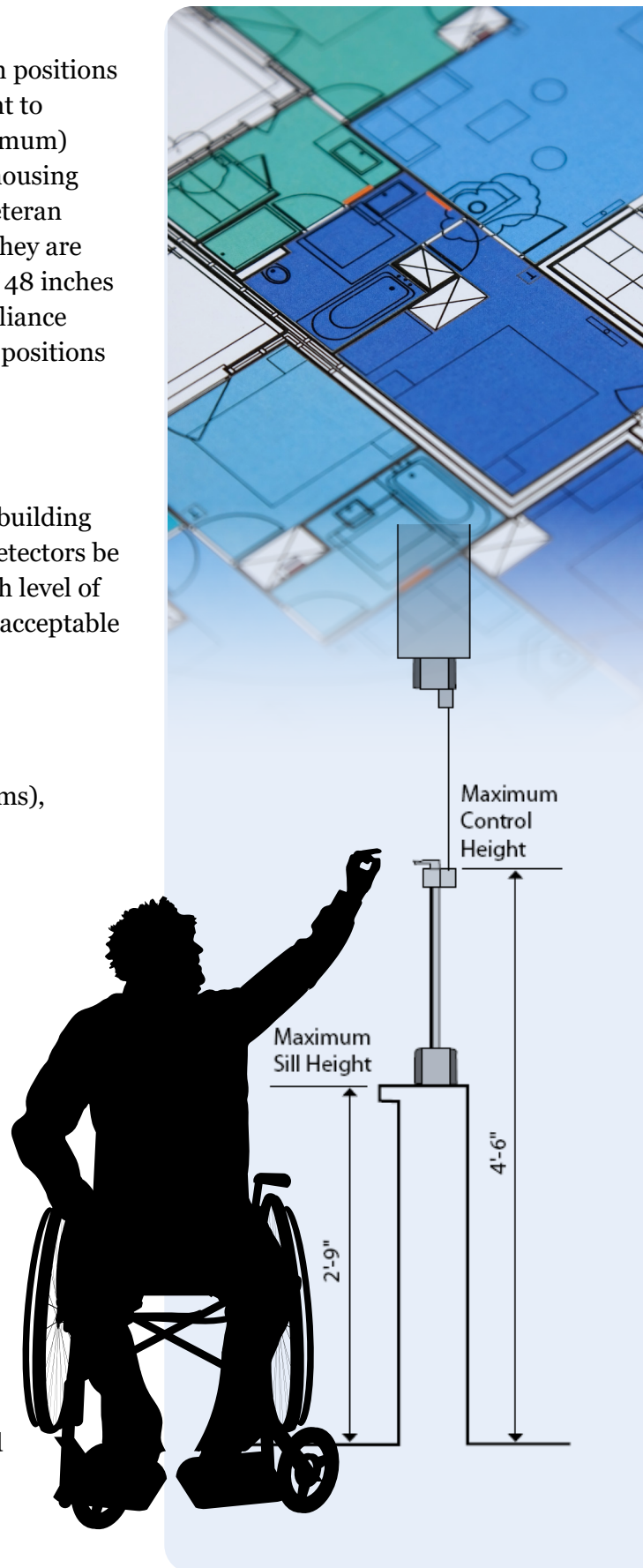

Note: Replacing older, worn carpet that impedes wheelchair maneuverability is acceptable, but the carpet installed must be low pile, closely woven, and padded with a durable fiber pad. Use of the grant is not intended to replace older, worn carpet simply for aesthetic purposes.



Flooring Materials

It is reasonable to replace floor coverings in rooms the Veteran accesses; however, the type of floor covering used must not impede maneuverability. When possible, floor coverings should be durable and low maintenance (e.g., hardwood, ceramic tile or vinyl). Interior floor coverings at ingress and egress points should be of non-slip materials under both wet and dry conditions. Carpeted floor coverings should be low pile, closely woven, and padded with a durable fiber type.

Laundry Room

An adapted laundry room should have:

- a clear area for maneuvering with a minimum diameter of 5 feet,
- a front loading washer and dryer, and
- washer and dryer stands, if necessary.

Special Equipment

Special equipment is deemed reasonably necessary if it is required to preserve the Veteran's health or contributes to his/her quality of life. Because there are other sources of funding for special equipment, such as Prosthetics and Sensory Aids and Veteran Readiness and Employment, it is important that Veterans work with other program areas to maximize any and all available benefits. The following special equipment is considered to be reasonably necessary:

- elevators,
- VPLs,
- stair lifts,
- ceiling track systems, and
- adaptive equipment used to improve the quality of life.

Some special equipment must be approved prior to grant approval and requires a request from the Veteran, along with justification for the request. This includes:

- whole house generators,
- pools,
- therapy tubs or hot tubs, and
- any special equipment not included in this section.

Recommended Adaptations for Burn Injuries or Respiratory Related Injuries

Veterans with respiratory related injuries, or severe burn injuries that reduce range of motion, may have needs that differ from other SAH eligible Veterans. In addition to the other MPRs and RAs presented in this section, the following adaptations are deemed reasonably necessary for Veterans with burn injuries or respiratory related injuries:

- A larger bathtub or walk-in tub to minimize the range of motion required to enter/exit
- Enlarged showers to accommodate seating
- Motion/touch sensing faucets and light switches
- Integrated, whole-house climate and lighting controls (smart controls)
- Automatic door openers
- Accessible, custom closets and shelving
- Covered or enclosed patios, porches, entryways, retractable awnings, window tinting, and/or window coverings to control sun exposure on the interior and exterior
- Conversion of basement areas to finished living areas that provide a comfortable environment free of sun exposure
- Room additions to store exercise equipment and/or other hobby-related equipment
- Maintenance-free building materials
- Invisible fencing, pet doors, and any other equipment related to accommodating a service dog assigned to the Veteran
- Air filtration and dehumidifying systems
- Replacement of carpet with hard surface flooring for dust control

As the types of injuries and treatments continue to change, new and creative adaptations may be deemed reasonably necessary. For adaptations that are not included on this list, a request must be submitted by the Veteran, along with justification, prior to grant approval.



Section 7:

SHA Recommended Adaptations

Overview

RAs are suggested modifications and are not required for grant approval. There are no MPRs for SHA grants. RAs were developed over time by SAH experts who have gained an understanding of the residential needs of Veterans eligible for the SHA grant.

There is a need for flexibility and the exercise of good judgment based on the physical capabilities and limitations of each Veteran. Equally important is the need to anticipate the Veteran's future needs. SAH Agents will assist the Veteran in using a modular approach to adapting the housing unit. That is, RAs should be chosen by the Veteran on an as needed, or as desired, basis once the MPRs have been satisfied.

Because RAs are not required for grant approval, a waiver process is **not** necessary. Nor is it a requirement that every RA be incorporated into the design of each room, or area, being adapted. Veterans have freedom of choice and may select individual features. The specifications provided for each RA in this section are not absolute. However, they should be adhered to when possible as they represent adaptations that have been field tested. VA has flexibility in approving minor variations in the specifications provided in this section and a formal approval process is **not** required. However, VA will exercise sound judgment in determining which variations are acceptable. If the variation is significant, VA will question whether the proposed work represents an adapted feature.

Although the purpose of creating RAs is to introduce greater flexibility to the SAH Grant program, it is important to remember that grant funds can only be used for adaptations that benefit the Veteran. CO may consider exceptions to this rule if it is determined that the proposed adaptations are necessary for the Veteran's caregiver and will improve the Veteran's quality of life. The request must be submitted by the Veteran, along with justification for the adaptation.

The list of RAs is substantial, but not all-inclusive. Therefore, if a Veteran desires an adaptation not included in this section, a request must be submitted by the Veteran, along with justification for the adaptation.

Section 8: Grant Plans and Determining the Grant Amount

MAKE YOURSELF AT HOME
VA's Adapted Housing Grants for Disabled Veterans

DID YOU KNOW?
VA offers monetary assistance to Veterans with specific service-connected physical disabilities, so they can construct or modify a home to best meet their needs.

WHAT RENOVATIONS QUALIFY?

- Bathrooms, kitchens, and bedrooms
- Covered porches, ramps, and walkways
- Garages, carports, and passageways
- Doors, windows, and flooring materials
- Security items
- Concrete or asphalt walkways
- Sliding doors, handrails, and grab bars

For a full list, contact: sahinfo.vbaco@va.gov

To learn more, visit www.benefits.va.gov/homeloans or call 1-800-827-1000

WHO IS ELIGIBLE?
Veterans or Service members, with a permanent and total service-connected disability, who have experienced one or more of the following conditions:

- Loss of or loss of use of both arms and/or both legs
- Blindness in both eyes or only light perception
- Certain severe burns
- Certain severe respiratory injuries

For additional eligibility information, contact: sahinfo.vbaco@va.gov

HOW TO APPLY:
Fill out and submit VA Form 26-4555 at www.eBenefits.va.gov or call 1-800-827-1000 to have a claim form mailed to you.

Overview

In Section 1 of this handbook, the different ways that the SAH, SHA, and TRA grants may be used were briefly mentioned. The law related to the SAH program establishes the plan types for the SAH, SHA, and TRA grants, as well as, the formulas used to calculate the amount of assistance available under each of these plan types. In this section, each of the plan types will be presented as well as the calculations used to determine the grant amounts.

The maximum grant amount is reviewed annually and potential increases are based on fluctuations in the designated construction cost index. The Secretary of VA announces any increase in the maximum grant amount at the beginning of each fiscal year. Grant amounts will not decrease from year to year even if the index indicates a decrease in construction costs. No eligible individual may use the SAH or SHA grant benefit more than three times, up to the maximum dollar amount allowed. The TRA grant may be used only once, up to the maximum dollar amount allowed.

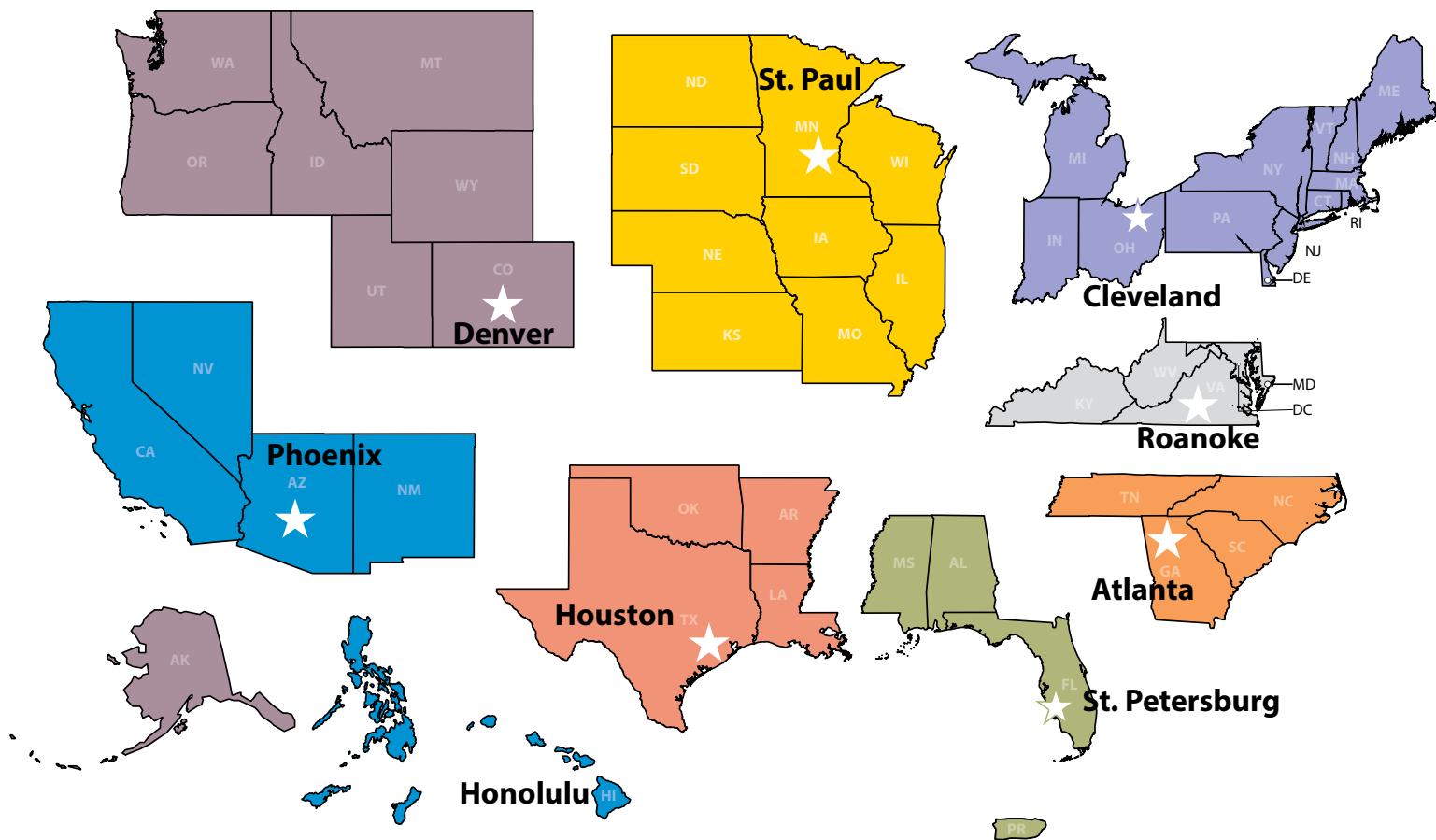

Regional Loan Center Contact Information

To reach the nearest VA Regional Office with Loan Guaranty operations, please call 1-877-827-3702.

Regional Loan Center	Jurisdiction	Mailing Addresses
★ Atlanta www.benefits.va.gov/atlanta/regional-loan-center.asp	Georgia North Carolina South Carolina Tennessee	Department of Veterans Affairs VA Regional Loan Center 1700 Clairmont Rd. Decatur, GA 30033-4032 (Mail: P.O. Box 100023, Decatur, GA 30031-7023)
★ Cleveland www.benefits.va.gov/cleveland/regional-loan-center.asp	Connecticut Delaware Indiana Maine Massachusetts Michigan New Hampshire New Jersey New York Ohio Pennsylvania Rhode Island Vermont	Department of Veterans Affairs VA Regional Loan Center 1240 East Ninth Street Cleveland, OH 44199

Regional Loan Center	Jurisdiction	Mailing Addresses
★ Denver www.benefits.va.gov/denver/regional-loan-center.asp	Alaska Colorado Idaho Montana Oregon Utah Washington Wyoming	Department of Veterans Affairs VA Regional Loan Center 155 Van Gordon Street Lakewood, CO 80228 (Mail: Box 25126, Denver, CO 80225)
★ Phoenix www.benefits.va.gov/phoenix/regional-loan-center.asp	Arizona California New Mexico Nevada	Department of Veterans Affairs VA Regional Loan Center 3333 N. Central Avenue Phoenix, AZ 85012-2402
★ Honolulu* www.benefits.va.gov/honolulu/regional-loan-center.asp *Although not an RLC, this office is a fully functioning Loan Guaranty office.	Hawaii Guam American Samoa Commonwealth of the Northern Marianas	Department of Veterans Affairs VA Regional Office Loan Guaranty Division (26) 459 Patterson Rd. Honolulu, HI 96819
★ Houston www.benefits.va.gov/houston/regional-loan-center.asp	Arkansas Louisiana Oklahoma Texas	Department of Veterans Affairs VA Regional Loan Center 6900 Almeda Road Houston, TX 77030-4200
★ Roanoke www.benefits.va.gov/roanoke/regional-loan-center.asp	District of Columbia Kentucky Maryland Virginia West Virginia	Department of Veterans Affairs VA Regional Loan Center 210 Franklin Road, S.W. Roanoke, VA 24011
★ St. Paul www.benefits.va.gov/stpaul/regional-loan-center.asp	Illinois Iowa Kansas Minnesota Missouri Nebraska North Dakota South Dakota Wisconsin	Department of Veterans Affairs VA Regional Loan Center 1 Federal Drive, Ft. Snelling St. Paul, MN 55111-4050
★ St. Petersburg http://www.benefits.va.gov/stpetersburg/regional-loan-center.asp	Alabama Florida Mississippi Puerto Rico U.S. Virgin Islands	Department of Veterans Affairs VA Regional Loan Center 9500 Bay Pines Blvd. St. Petersburg, FL 33708 (Mail: P.O. Box 1437, St. Petersburg, FL 33731)



VA



U.S. Department of Veterans Affairs

Veterans Benefits Administration