

# *Grizzly* **Industrial, Inc.**®

## **MODEL G0562Z/G0562ZP/ G1030Z2/G1030Z2P DUST COLLECTOR OWNER'S MANUAL** *(For models manufactured since 11/11)*



COPYRIGHT © DECEMBER, 2011 BY GRIZZLY INDUSTRIAL, INC., REVISED DECEMBER, 2017 (HE)  
**WARNING: NO PORTION OF THIS MANUAL MAY BE REPRODUCED IN ANY SHAPE  
OR FORM WITHOUT THE WRITTEN APPROVAL OF GRIZZLY INDUSTRIAL, INC.**  
#BL14619 PRINTED IN TAIWAN

V4.12.17



## **WARNING!**

**This manual provides critical safety instructions on the proper setup, operation, maintenance, and service of this machine/tool. Save this document, refer to it often, and use it to instruct other operators.**

**Failure to read, understand and follow the instructions in this manual may result in fire or serious personal injury—including amputation, electrocution, or death.**

**The owner of this machine/tool is solely responsible for its safe use. This responsibility includes but is not limited to proper installation in a safe environment, personnel training and usage authorization, proper inspection and maintenance, manual availability and comprehension, application of safety devices, cutting/sanding/grinding tool integrity, and the usage of personal protective equipment.**

**The manufacturer will not be held liable for injury or property damage from negligence, improper training, machine modifications or misuse.**



## **WARNING!**

**Some dust created by power sanding, sawing, grinding, drilling, and other construction activities contains chemicals known to the State of California to cause cancer, birth defects or other reproductive harm. Some examples of these chemicals are:**

- **Lead from lead-based paints.**
- **Crystalline silica from bricks, cement and other masonry products.**
- **Arsenic and chromium from chemically-treated lumber.**

**Your risk from these exposures varies, depending on how often you do this type of work. To reduce your exposure to these chemicals: Work in a well ventilated area, and work with approved safety equipment, such as those dust masks that are specially designed to filter out microscopic particles.**

# Table of Contents

<b>INTRODUCTION</b> .....	<b>2</b>	<b>SECTION 6: ACCESSORIES</b> .....	<b>29</b>
Manual Accuracy .....	2	<b>SECTION 7: MAINTENANCE</b> .....	<b>32</b>
Contact Info.....	2	Schedule .....	32
Machine Description .....	2	Lubrication .....	32
Identification.....	3	Bag Cleaning .....	32
Machine Data Sheet.....	4	Emptying/Replacing Bags.....	33
<b>SECTION 1: SAFETY</b> .....	<b>6</b>	Cleaning Canister Filter .....	33
Safety Instructions for Machinery .....	6	<b>SECTION 8: SERVICE</b> .....	<b>34</b>
Additional Safety for Dust Collectors .....	8	Troubleshooting .....	34
<b>SECTION 2: POWER SUPPLY</b> .....	<b>9</b>	Motor & Electrical .....	34
Availability.....	9	Dust Collector Operation .....	35
Full-Load Current Rating .....	9	<b>SECTION 9: WIRING</b> .....	<b>36</b>
Circuit Information .....	9	Wiring Safety Instructions .....	36
Circuit Requirements for 240V .....	9	Wiring Diagram .....	37
Grounding Requirements .....	10	<b>SECTION 10: PARTS</b> .....	<b>38</b>
Extension Cords .....	10	G0562Z/G1030Z2 Main Breakdown .....	38
<b>SECTION 3: SETUP</b> .....	<b>11</b>	H5783 Canister Filter Assembly .....	39
Needed for Setup.....	11	G0562ZP/G1030Z2P Main Breakdown .....	40
Unpacking.....	11	<b>WARRANTY AND RETURNS</b> .....	<b>45</b>
Inventory .....	12		
Site Considerations.....	14		
Weight Load .....	14		
Space Allocation.....	14		
Physical Environment.....	14		
Electrical Installation.....	14		
Lighting .....	14		
Assembly .....	15		
Test Run .....	19		
<b>SECTION 4: DESIGNING THE SYSTEM</b> .....	<b>20</b>		
General .....	20		
Duct Material.....	20		
Metal Duct .....	20		
Flexible Duct.....	21		
Plastic Duct.....	21		
System Design.....	22		
Step 1. Decide Who Will Design .....	22		
Step 2. Sketch Your Shop Layout.....	22		
Step 3. Sketch a Basic Duct Layout.....	22		
Step 4. Determine Required CFM of Each Machine .....	23		
Determining Main Line Duct Size .....	24		
Determining Branch Line Duct Size .....	24		
Calculating Duct Resistance .....	25		
System Grounding .....	26		
<b>SECTION 5: OPERATIONS</b> .....	<b>28</b>		
General .....	28		
Machine Storage.....	28		

# INTRODUCTION

## Manual Accuracy

We are proud to provide a high-quality owner's manual with your new machine!

We made every effort to be exact with the instructions, specifications, drawings, and photographs in this manual. Sometimes we make mistakes, but our policy of continuous improvement also means that **sometimes the machine you receive is slightly different than shown in the manual.**

If you find this to be the case, and the difference between the manual and machine leaves you confused or unsure about something, check our website for an updated version. We post current manuals and manual updates for free on our website at **www.grizzly.com**.

Alternatively, you can call our Technical Support for help. Before calling, make sure you write down the **Manufacture Date** and **Serial Number** from the machine ID label (see below). This information is required for us to provide proper tech support, and it helps us determine if updated documentation is available for your machine.

**Grizzly Industrial** MODEL GXXXX  
MACHINE NAME

SPECIFICATIONS	WARNING!
Motor:	To reduce risk of serious injury when using this machine:
Specification:	1. Read manual before operation.
Specification:	2. Wear safety glasses and respirator.
Specification:	3. Make sure machine is properly adjusted/setup and
Specification:	4. Make sure the motor has stopped and disconnect
Weight:	5. DO NOT expose to rain or dampness.
	6. DO NOT modify this machine in any way.
	7.
	8.
	9. Do not use while under the influence of drugs or alcohol.
	10. Maintain machine carefully to prevent accidents.

Manufacture Date: [Date]

Serial Number: [Serial Number]

Manufactured for Grizzly in Taiwan

## Contact Info

We stand behind our machines! If you have questions or need help, contact us with the information below. Before contacting, make sure you get the **serial number** and **manufacture date** from the machine ID label. This will help us help you faster.

Grizzly Technical Support  
1815 W. Battlefield  
Springfield, MO 65807  
Phone: (570) 546-9663  
Email: techsupport@grizzly.com

We want your feedback on this manual. What did you like about it? Where could it be improved? Please take a few minutes to give us feedback.

Grizzly Documentation Manager  
P.O. Box 2069  
Bellingham, WA 98227-2069  
Email: manuals@grizzly.com

## Machine Description

This machine is designed to capture dust and wood chips from multiple woodworking machines at the same time.

A wide variety of accessories for setting up a stationary or mobile dust collection system are available through Grizzly.



# Identification



Figure 2. Model G0562Z/G1030Z2 identification.





# MACHINE DATA SHEET

Customer Service #: (570) 546-9663 · To Order Call: (800) 523-4777 · Fax #: (800) 438-5901

## MODEL G0562Z/G0562ZP, G1030Z2/1030Z2P DUST COLLECTORS

Model Number	G0562Z/G0562ZP	G1030Z2/G1030Z2P
<b>Product Dimensions</b>		
Weight	187 lbs.	156 lbs.
Width (side-to-side)/Depth (front-to-back)/Height	57-7/8 x 32 x 71 in.	49-1/2 x 21-1/2 x 78 in.
Foot Print (Width/Depth)	49-1/2 x 21-1/2 in.	
<b>Shipping Dimensions</b>		
<b>Carton 1</b>		
Type	Cardboard	
Content	Machine	
Weight	165 lbs.	170 lbs.
Width (side-to-side)/Depth (front-to-back)/Height	52 x 23 x 24 in.	51 x 22 x 23 in.
<b>Carton 2</b>		
Type	Cardboard	Not Applicable
Content	Canister	
Weight	29 lbs.	
Width (side-to-side)/Depth (front-to-back)/Height	22 x 22 x 28 in.	
<b>Electrical</b>		
Power Requirement	240V, Single-Phase, 60 Hz	
Minimum Circuit Size	20A	
Switch	Safety Paddle Switch	
Switch Voltage	240V	
Cord Length	6 ft.	6 ft.
Cord Gauge	14 AWG	14 AWG
Plug Included	Yes	
Included Plug Type	NEMA 6-20	
<b>Main Motor</b>		
Type	TEFC Capacitor Start Induction	
Horsepower	3 HP	
Voltage	240V	
Phase	Single-Phase	
Amps	12A	
Speed	3450 RPM	
Cycle	60 Hz	
Power Transfer	Direct Drive	
Bearings	Shielded & Permanently Lubricated	



<b>Model Number</b>	<b>G0562Z/G0562ZP</b>		<b>G1030Z2/G1030Z2P</b>	
<b>Operation Information</b>				
Type	Canister		Bag	
Air Suction Capacity	2320 CFM		2300 CFM	
Maximum Static Pressure	16.9 in.		16.7 in.	
Main Inlet Size	7 in.			
Manifold Included	Yes			
Manifold Inlets	3			
Manifold Inlet Size	4 in.			
Maximum Material Collection Capacity	11.4 cu. ft.			
Canister or Upper Bag Filtration	1 Micron		2.5 Micron	
<b>Bag Information</b>				
Number of Upper Bags	NA		2	
Upper Bag Capacity	NA		5.7 cu. ft.	
Upper Bags Total Area	NA		5.7 cu. ft.	
Upper Bag Diameter	NA		19-1/2 in.	
Upper Bag Length	NA		33 in.	
Number of Lower Bags	2			
Lower Bag Capacity	5.7 cu. ft.			
Lower Bags Total Area	11.4 cu. ft.			
Lower Bag Diameter	19-1/2 in.			
Lower Bag Length	41 in.			
<b>Impeller Information</b>				
Impeller Type	Radial Fin			
Impeller Size	12-3/4 in.			
Impeller Blade Thickness	1/8 in.			
<b>Construction</b>				
Upper Bag	NA		Fabric	
Lower Bag	Clear Plastic			
Canister	Spun Bond Polyester		NA	
Base	Fabricated Sheet Metal with Casters			
Frame	Fabricated Sheet Metal		Formed Steel	
Caster	High Density Plastic			
Impeller	Cast Aluminum			
Paint	Powder Coated			
Paint Color	Grizzly Green	Polar Bear White	Grizzly Green	Polar Bear White
<b>Other</b>				
Height with Bags Inflated	71 in.		78 in.	
ISO Factory	ISO 9001			
Country of Origin	Taiwan			
Warranty	1 Year			
Serial Number Location	On ID Label			
Assembly Time	1 Hour			
Awards	Wood Magazine Top Value 1997			



# SECTION 1: SAFETY

## For Your Own Safety, Read Instruction Manual Before Operating This Machine

The purpose of safety symbols is to attract your attention to possible hazardous conditions. This manual uses a series of symbols and signal words intended to convey the level of importance of the safety messages. The progression of symbols is described below. Remember that safety messages by themselves do not eliminate danger and are not a substitute for proper accident prevention measures. Always use common sense and good judgment.

 **DANGER** Indicates an imminently hazardous situation which, if not avoided, **WILL** result in death or serious injury.

 **WARNING** Indicates a potentially hazardous situation which, if not avoided, **COULD** result in death or serious injury.

 **CAUTION** Indicates a potentially hazardous situation which, if not avoided, **MAY** result in minor or moderate injury. It may also be used to alert against unsafe practices.

**NOTICE** This symbol is used to alert the user to useful information about proper operation of the machine.

## Safety Instructions for Machinery

### **WARNING**

**OWNER'S MANUAL.** Read and understand this owner's manual **BEFORE** using machine.

**TRAINED OPERATORS ONLY.** Untrained operators have a higher risk of being hurt or killed. Only allow trained/supervised people to use this machine. When machine is not being used, disconnect power, remove switch keys, or lock-out machine to prevent unauthorized use—especially around children. Make your workshop kid proof!

**DANGEROUS ENVIRONMENTS.** Do not use machinery in areas that are wet, cluttered, or have poor lighting. Operating machinery in these areas greatly increases the risk of accidents and injury.

**MENTAL ALERTNESS REQUIRED.** Full mental alertness is required for safe operation of machinery. Never operate under the influence of drugs or alcohol, when tired, or when distracted.

**ELECTRICAL EQUIPMENT INJURY RISKS.** You can be shocked, burned, or killed by touching live electrical components or improperly grounded machinery. To reduce this risk, only allow qualified service personnel to do electrical installation or repair work, and always disconnect power before accessing or exposing electrical equipment.

**DISCONNECT POWER FIRST.** Always disconnect machine from power supply **BEFORE** making adjustments, changing tooling, or servicing machine. This prevents an injury risk from unintended startup or contact with live electrical components.

**EYE PROTECTION.** Always wear ANSI-approved safety glasses or a face shield when operating or observing machinery to reduce the risk of eye injury or blindness from flying particles. Everyday eyeglasses are **NOT** approved safety glasses.





# WARNING

**WEARING PROPER APPAREL.** Do not wear clothing, apparel or jewelry that can become entangled in moving parts. Always tie back or cover long hair. Wear non-slip footwear to reduce risk of slipping and losing control or accidentally contacting cutting tool or moving parts.

**HAZARDOUS DUST.** Dust created by machinery operations may cause cancer, birth defects, or long-term respiratory damage. Be aware of dust hazards associated with each workpiece material. Always wear a NIOSH-approved respirator to reduce your risk.

**HEARING PROTECTION.** Always wear hearing protection when operating or observing loud machinery. Extended exposure to this noise without hearing protection can cause permanent hearing loss.

**REMOVE ADJUSTING TOOLS.** Tools left on machinery can become dangerous projectiles upon startup. Never leave chuck keys, wrenches, or any other tools on machine. Always verify removal before starting!

**USE CORRECT TOOL FOR THE JOB.** Only use this tool for its intended purpose—do not force it or an attachment to do a job for which it was not designed. Never make unapproved modifications—modifying tool or using it differently than intended may result in malfunction or mechanical failure that can lead to personal injury or death!

**AWKWARD POSITIONS.** Keep proper footing and balance at all times when operating machine. Do not overreach! Avoid awkward hand positions that make workpiece control difficult or increase the risk of accidental injury.

**CHILDREN & BYSTANDERS.** Keep children and bystanders at a safe distance from the work area. Stop using machine if they become a distraction.

**GUARDS & COVERS.** Guards and covers reduce accidental contact with moving parts or flying debris. Make sure they are properly installed, undamaged, and working correctly BEFORE operating machine.

**FORCING MACHINERY.** Do not force machine. It will do the job safer and better at the rate for which it was designed.

**NEVER STAND ON MACHINE.** Serious injury may occur if machine is tipped or if the cutting tool is unintentionally contacted.

**STABLE MACHINE.** Unexpected movement during operation greatly increases risk of injury or loss of control. Before starting, verify machine is stable and mobile base (if used) is locked.

**USE RECOMMENDED ACCESSORIES.** Consult this owner's manual or the manufacturer for recommended accessories. Using improper accessories will increase the risk of serious injury.

**UNATTENDED OPERATION.** To reduce the risk of accidental injury, turn machine **OFF** and ensure all moving parts completely stop before walking away. Never leave machine running while unattended.

**MAINTAIN WITH CARE.** Follow all maintenance instructions and lubrication schedules to keep machine in good working condition. A machine that is improperly maintained could malfunction, leading to serious personal injury or death.

**DAMAGED PARTS.** Regularly inspect machine for damaged, loose, or mis-adjusted parts—or any condition that could affect safe operation. Immediately repair/replace BEFORE operating machine. For your own safety, DO NOT operate machine with damaged parts!

**MAINTAIN POWER CORDS.** When disconnecting cord-connected machines from power, grab and pull the plug—NOT the cord. Pulling the cord may damage the wires inside. Do not handle cord/plug with wet hands. Avoid cord damage by keeping it away from heated surfaces, high traffic areas, harsh chemicals, and wet/damp locations.

**EXPERIENCING DIFFICULTIES.** If at any time you experience difficulties performing the intended operation, stop using the machine! Contact our Technical Support at (570) 546-9663.



# Additional Safety for Dust Collectors

## WARNING

**INTENDED USE.** This dust collector is only intended for collecting wood dust and chips from woodworking machines. DO NOT use this dust collector to collect metal, dirt, pebbles, drywall, asbestos, lead paint, silica, liquids, aerosols, or any flammable, combustible, or hazardous materials.

**HAZARDOUS DUST.** Dust created while using machinery may cause cancer, birth defects, or long-term respiratory damage. Be aware of dust hazards associated with each workpiece material, and always wear a NIOSH-approved respirator to reduce your risk.

**DUST ALLERGIES.** Dust from certain woods may cause an allergic reaction in people and animals. Make sure you know what type of wood dust you will be exposed to in case there is a possibility of an allergic reaction.

**WEAR RESPIRATOR.** Fine dust that is too small to be caught in the filter will be blown into the ambient air during operation. Always wear a NIOSH approved respirator during operation and for a short time after to reduce your risk of permanent respiratory damage.

**EMPTYING DUST.** When emptying dust from the collection container, wear a respirator and safety glasses. Empty dust away from ignition sources and into an approved container.

**DISCONNECTING POWER SUPPLY.** Turn the switch **OFF**, disconnect the dust collector from the power supply, and allow the impeller to come to a complete stop before leaving the machine unattended or doing any service, cleaning, maintenance, or adjustments.

**REGULAR CLEANING.** Regularly check/empty the collection bags or drum to avoid the buildup of fine dust that can increase the risk of fire. Make sure to regularly clean the surrounding area where the machine is operated—excessive dust buildup on overhead lights, heaters, electrical panels, or other heat sources will increase the risk of fire.

**SUSPENDED DUST PARTICLES AND IGNITION SOURCES.** DO NOT operate the dust collector in areas where explosion risks are high. Areas of high risk include, but are not limited to, areas near pilot lights, open flames, or other ignition sources.

**FIRE SUPPRESSION.** Only operate the dust collector in locations that contain a fire suppression system or have a fire extinguisher nearby.

**IMPELLER HAZARDS.** DO NOT place your hands or tools near the open inlet during operation for any reason. The powerful suction could easily cause accidental contact with the impeller which will cause serious personal injury or damage to the machine. Always keep small animals and children away from open dust collection inlets.

**AVOIDING SPARKS.** DO NOT allow steel or rocks to strike the impeller—this may produce sparks. Sparks can smolder in wood dust for a long time before a fire is detected. If you accidentally cut into wood containing tramp metal (nails, staples, spikes, etc.), immediately turn **OFF** the dust collector, disconnect it from power, and wait for the impeller to stop—then empty the collection container into an approved airtight metal container.

**OPERATING LOCATION.** To reduce respiratory exposure to fine dust, locate permanently installed dust collectors away from the working area, or in another room that is equipped with a smoke detector. DO NOT operate the dust collector in rainy or wet locations—exposure to water may create a shock hazard or decrease the life of the machine.

**STATIC ELECTRICITY.** Plastic dust lines generate high amounts of static electricity as dust chips pass through them. Although rare, sparks caused by static electricity can cause explosions or fire. To reduce this risk, make sure all dust lines are thoroughly grounded by using a grounding wire.



# SECTION 2: POWER SUPPLY

## Availability

Before installing the machine, consider the availability and proximity of the required power supply circuit. If an existing circuit does not meet the requirements for this machine, a new circuit must be installed. To minimize the risk of electrocution, fire, or equipment damage, installation work and electrical wiring must be done by an electrician or qualified service personnel in accordance with all applicable codes and standards.

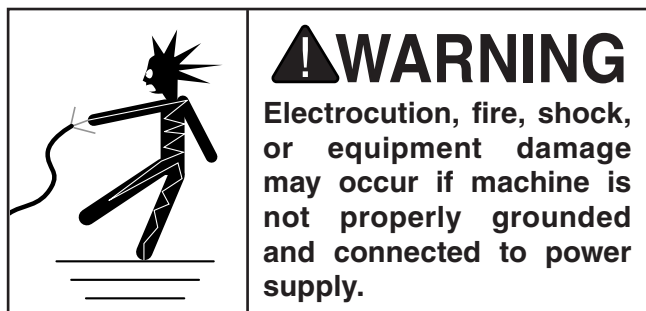

## Full-Load Current Rating

The full-load current rating is the amperage a machine draws at 100% of the rated output power. On machines with multiple motors, this is the amperage drawn by the largest motor or sum of all motors and electrical devices that might operate at one time during normal operations.

### Full-Load Current Rating at 240V ..... 12 Amps

The full-load current is not the maximum amount of amps that the machine will draw. If the machine is overloaded, it will draw additional amps beyond the full-load rating.

If the machine is overloaded for a sufficient length of time, damage, overheating, or fire may result—especially if connected to an undersized circuit. To reduce the risk of these hazards, avoid overloading the machine during operation and make sure it is connected to a power supply circuit that meets the specified circuit requirements.

## **! WARNING**

**Serious injury could occur if you connect machine to power before completing setup process. DO NOT connect to power until instructed later in this manual.**

## Circuit Information

A power supply circuit includes all electrical equipment between the breaker box or fuse panel in the building and the machine. The power supply circuit used for this machine must be sized to safely handle the full-load current drawn from the machine for an extended period of time. (If this machine is connected to a circuit protected by fuses, use a time delay fuse marked D.)

## **! CAUTION**

**For your own safety and protection of property, consult an electrician if you are unsure about wiring practices or electrical codes in your area.**

**Note:** *Circuit requirements in this manual apply to a dedicated circuit—where only one machine will be running on the circuit at a time. If machine will be connected to a shared circuit where multiple machines may be running at the same time, consult an electrician or qualified service personnel to ensure circuit is properly sized for safe operation.*

## Circuit Requirements for 240V

This machine is prewired to operate on a power supply circuit that has a verified ground and meets the following requirements:

**Nominal Voltage ..... 220V/240V**  
**Cycle ..... 60 Hz**  
**Phase ..... Single-Phase**  
**Power Supply Circuit ..... 20 Amps**  
**Plug/Receptacle ..... NEMA 6-20**



## Grounding Requirements

This machine **MUST** be grounded. In the event of certain malfunctions or breakdowns, grounding reduces the risk of electric shock by providing a path of least resistance for electric current.

This machine is equipped with a power cord that has an equipment-grounding wire and a grounding plug. Only insert plug into a matching receptacle (outlet) that is properly installed and grounded in accordance with all local codes and ordinances. **DO NOT** modify the provided plug!

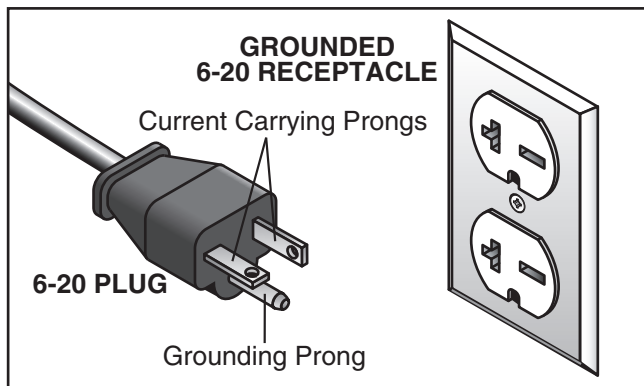

**Figure 3.** Typical 6-20 plug and receptacle.

 **CAUTION**

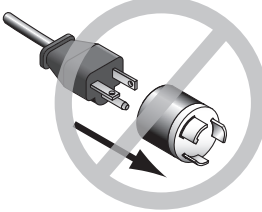

**No adapter should be used with plug. If plug does not fit available receptacle, or if machine must be reconnected for use on a different type of circuit, reconnection must be performed by an electrician or qualified service personnel, and it must comply with all local codes and ordinances.**

Improper connection of the equipment-grounding wire can result in a risk of electric shock. The wire with green insulation (with or without yellow stripes) is the equipment-grounding wire. If repair or replacement of the power cord or plug is necessary, do not connect the equipment-grounding wire to a live (current carrying) terminal.

Check with a qualified electrician or service personnel if you do not understand these grounding requirements, or if you are in doubt about whether the tool is properly grounded. If you ever notice that a cord or plug is damaged or worn, disconnect it from power, and immediately replace it with a new one.

## Extension Cords

We do not recommend using an extension cord with this machine. If you must use an extension cord, only use it if absolutely necessary and only on a temporary basis.

Extension cords cause voltage drop, which can damage electrical components and shorten motor life. Voltage drop increases as the extension cord size gets longer and the gauge size gets smaller (higher gauge numbers indicate smaller sizes).

Any extension cord used with this machine must be in good condition and contain a ground wire and matching plug/receptacle. Additionally, it must meet the following size requirements:

**Minimum Gauge Size .....14 AWG**  
**Maximum Length (Shorter is Better).....50 ft.**



# SECTION 3: SETUP

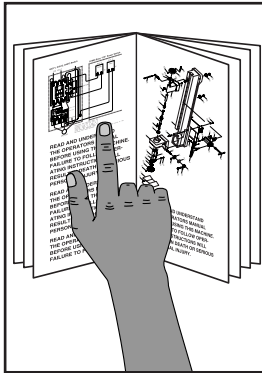

**!WARNING**  
This machine presents serious injury hazards to untrained users. Read through this entire manual to become familiar with the controls and operations before starting the machine!



**!WARNING**  
Wear safety glasses during the entire setup process!

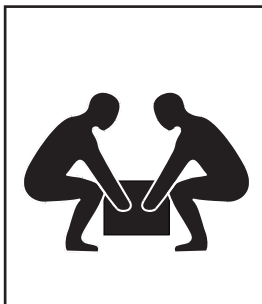

**!WARNING**  
This machine and its components are very heavy. Get lifting help or use power lifting equipment such as a forklift to move heavy items.

## Needed for Setup

The following are needed to complete the setup process, but are not included with your machine:

Description	Qty
• Safety Glasses (for each person).....	1
• Open End Wrench 12mm.....	1
• Phillips Head Screwdriver.....	1

## Unpacking

This machine was carefully packaged for safe transport. When unpacking, separate all enclosed items from packaging materials and inspect them for shipping damage. ***If items are damaged, please call us immediately at (570) 546-9663.***

**IMPORTANT:** Save all packaging materials until you are completely satisfied with the machine and have resolved any issues between Grizzly or the shipping agent. ***You MUST have the original packaging to file a freight claim. It is also extremely helpful if you need to return your machine later.***



**!WARNING**  
**SUFFOCATION HAZARD!**  
Keep children and pets away from plastic bags or packing materials shipped with this machine. Discard immediately.



# G0562Z-ZP Inventory

The following is a list of items shipped with your machine. Before beginning setup, lay these items out and inventory them.

If any non-proprietary parts are missing (e.g. a nut or a washer), we will gladly replace them; or for the sake of expediency, replacements can be obtained at your local hardware store.

Inventory Item	Qty
A. Canister Filter.....	2
B. Canister Filter Cleaning Handle .....	2
C. Foam Adhesive Bags .....	2
— Foam Strips 5 x 42mm .....	2
— Foam Strips 4 x 20mm .....	2
D. Metal Clamps.....	2



Figure 4. Canister filter components (G0562Z-ZP).

## NOTICE

If you cannot find an item on this list, carefully check around/inside the machine and packaging materials. Often, these items get lost in packaging materials while unpacking or they are pre-installed at the factory.

E. Motor and Impeller Assembly.....	1
F. 7" Inlet w/Three 4" Fittings .....	1
G. Base.....	1
H. Metal "Y" Outlet .....	1
I. Collector (Left) .....	1
J. Collector (Right).....	1
K. Hardware Bag.....	1
— Casters.....	4
— Phillips Head Tap Screw #10 x 3/8" .....	1
— Flange Bolts 5/16"-18 x 1/2" .....	52
— Combo Wrench 10 x 12mm.....	1
— Special Hex Wrench 5mm .....	1
L. Collector Supports .....	2
M. Collection Hardware Bag .....	1
— Metal Bag Clamps .....	4
— Clear Collection Bags.....	2
N. Rubber Gaskets (not shown).....	3

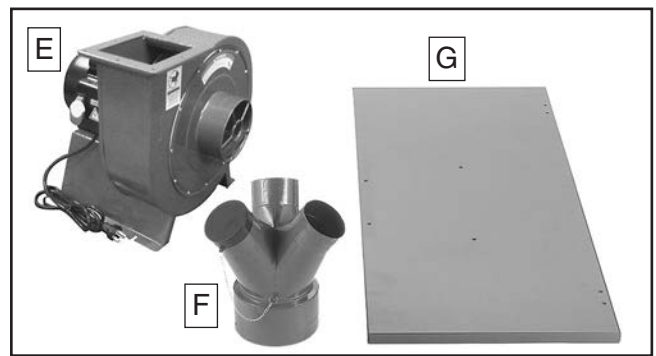

Figure 5. G0562Z-ZP inventory items (1).

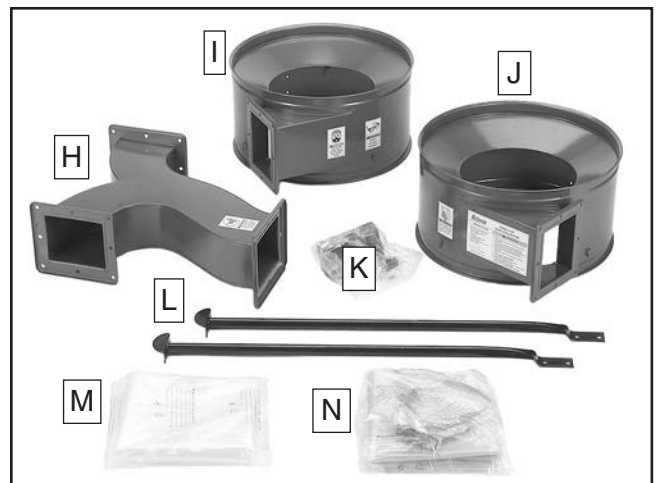

Figure 6. G0562Z-ZP inventory items (2).



# G1030Z2-Z2P Inventory

The following is a list of items shipped with your machine. Before beginning setup, lay these items out and inventory them.

If any non-proprietary parts are missing (e.g. a nut or a washer), we will gladly replace them; or for the sake of expediency, replacements can be obtained at your local hardware store.

Inventory Item	Qty
A. Upper Collection Bags.....	2



Figure 7. Upper collection bag (G1030Z2-Z2P).

## NOTICE

If you cannot find an item on this list, carefully check around/inside the machine and packaging materials. Often, these items get lost in packaging materials while unpacking or they are pre-installed at the factory.

B. Motor and Impeller Assembly.....	1
C. 7" Inlet w/Three 4" Fittings .....	1
D. Base.....	1
E. Metal "Y" Outlet .....	1
F. Collector (Right) .....	1
G. Collector (Left ).....	1
H. Hardware Bag.....	1
— Casters.....	4
— Phillips Head Tap Screw #10 x 3/8" .....	1
— Flange Bolts 5/16"-18 x 1/2" .....	52
— Combo Wrench 10 x 12mm.....	1
— Special Hex Wrench 5mm .....	1
I. Collector Supports .....	2
J. Collection Hardware Bag .....	1
— Metal Bag Clamps .....	4
— Clear Collection Bags .....	2
K. Foam Adhesive Bags .....	2
— Foam Strips 4 x 20mm .....	4
L. Rubber Gaskets (not shown).....	3
M. Upper Bag Supports (not shown).....	2

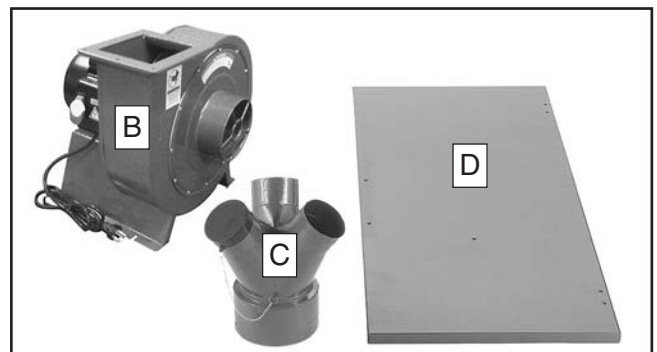

Figure 8. G1030Z2-Z2P inventory items (1).

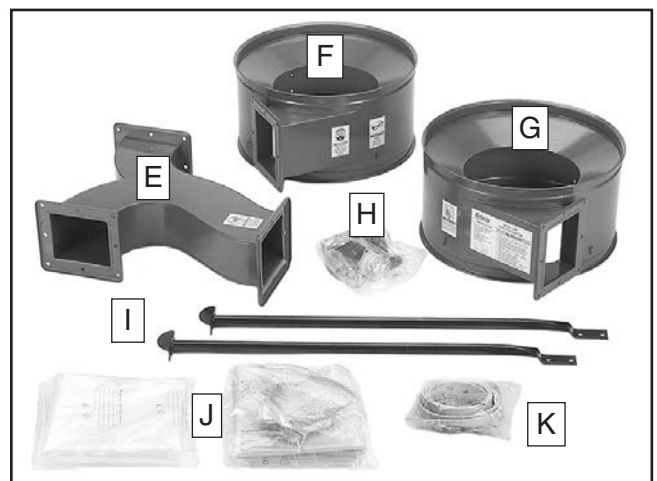

Figure 9. G1030Z2-Z2P inventory items (2).



# Site Considerations

## Weight Load

Refer to the **Machine Data Sheet** for the weight of your machine. Make sure that the surface upon which the machine is placed will bear the weight of the machine, additional equipment that may be installed on the machine, and the heaviest workpiece that will be used. Additionally, consider the weight of the operator and any dynamic loading that may occur when operating the machine.

## Space Allocation

Consider the largest size of workpiece that will be processed through this machine and provide enough space around the machine for adequate operator material handling or the installation of auxiliary equipment. With permanent installations, leave enough space around the machine to open or remove doors/covers as required by the maintenance and service described in this manual. **See below for required space allocation.**

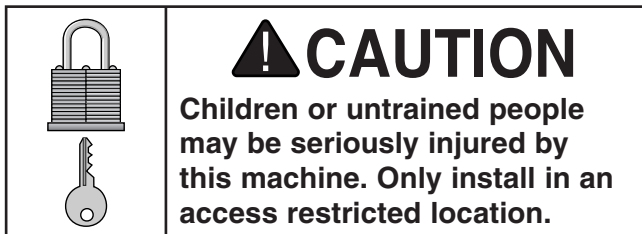

## Physical Environment

The physical environment where the machine is operated is important for safe operation and longevity of machine components. For best results, operate this machine in a dry environment that is free from excessive moisture, hazardous chemicals, airborne abrasives, or extreme conditions. Extreme conditions for this type of machinery are generally those where the ambient temperature range exceeds 41°–104°F; the relative humidity range exceeds 20%–95% (non-condensing); or the environment is subject to vibration, shocks, or bumps.

## Electrical Installation

Place this machine near an existing power source. Make sure all power cords are protected from traffic, material handling, moisture, chemicals, or other hazards. Make sure to leave enough space around machine to disconnect power supply or apply a lockout/tagout device, if required.

## Lighting

Lighting around the machine must be adequate enough that operations can be performed safely. Shadows, glare, or strobe effects that may distract or impede the operator must be eliminated.

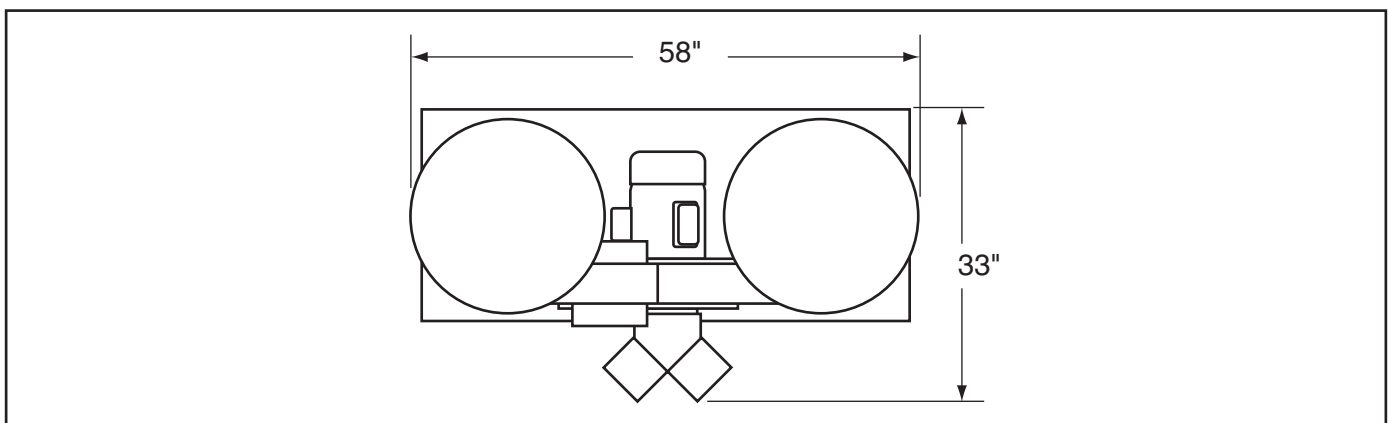

**Figure 10.** Minimum working clearances.





# Assembly

## To assemble your dust collector:

1. Place the base upside down on a clean, flat surface (to avoid scratching the paint).
2. Attach the casters to the base with (16)  $\frac{5}{16}$ "-18 x  $\frac{1}{2}$ " flange bolts, as shown in **Figure 11**.

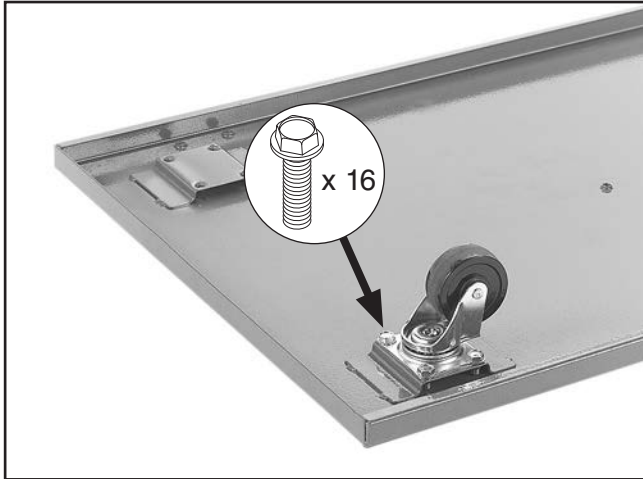

**Figure 11.** Caster installed onto the base.

3. Turn the base over, align the motor and impeller assembly with the mounting holes, then secure the assembly with (4)  $\frac{5}{16}$ "-18 x  $\frac{1}{2}$ " flange bolts, as shown in **Figure 12**.

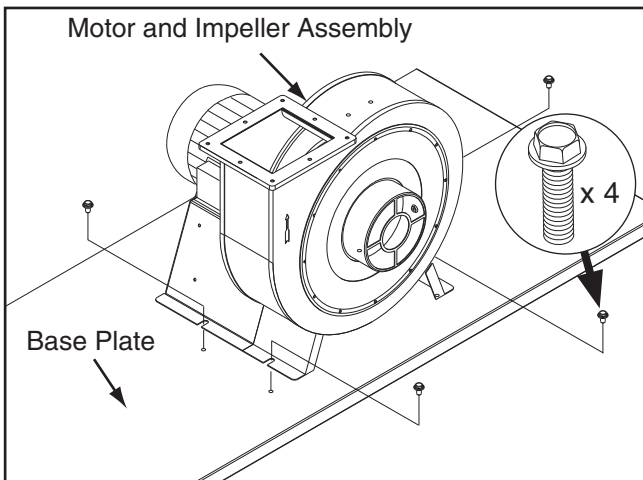

**Figure 12.** Motor and impeller assembly installed onto the base.

4. Place a rubber gasket around the impeller outlet rim, as shown in **Figure 13**.



**Figure 13.** Positioning impeller outlet gasket.

5. Secure the metal "Y" outlet to the impeller outlet with (8)  $\frac{5}{16}$ "-18 x  $\frac{1}{2}$ " flange bolts, as shown in **Figure 14**.

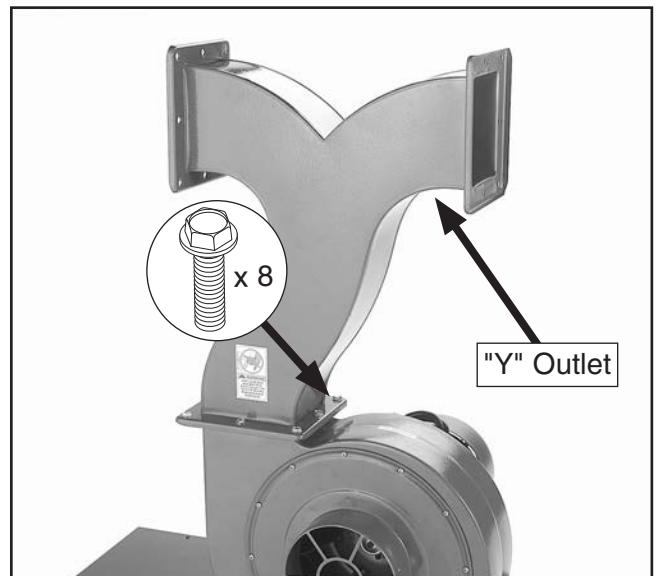

**Figure 14.** Outlet connector installed.



- Align each of the collector supports with the mounting holes on the base, as shown in **Figure 15**, then secure them in place with (4)  $\frac{5}{16}$ "-18 x  $\frac{1}{2}$ " flange bolts.

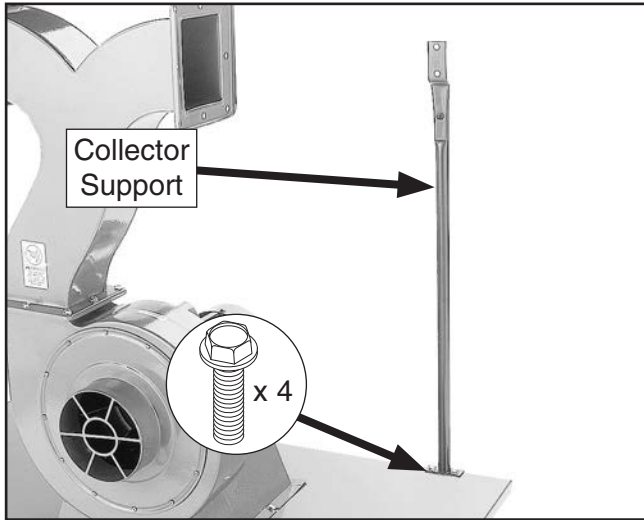

**Figure 15.** Collector support installed.

- With assistance, place one of the rubber gaskets around the rim of the intake on one of the collectors, then secure the collector to the metal "Y" outlet with (8)  $\frac{5}{16}$ "-18 x  $\frac{1}{2}$ " flange bolts (see **Figure 16**).

**Note:** The collector attaches to each support bracket. The inside of the collector is funnel shaped and directs the air around in a cyclonic motion.

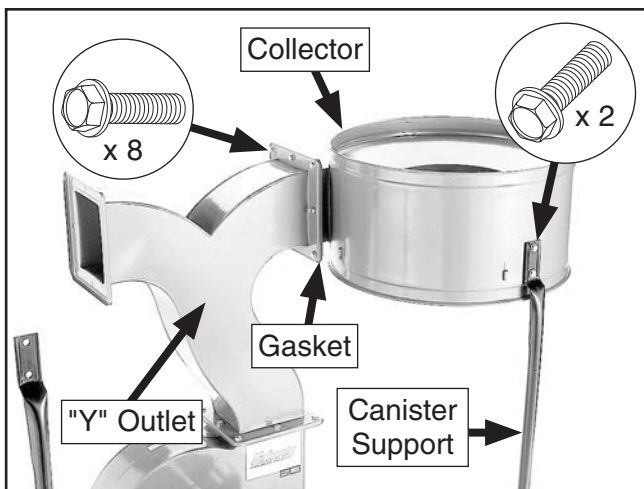

**Figure 16.** Collector installed.

- Attach the top of the canister support to the collector with (2)  $\frac{5}{16}$ "-18 x  $\frac{1}{2}$ " flange screws, as shown in **Figure 16**.

**G1030Z2/G1030Z2P only:** Place the upper bag support over the canister support and secure it with (2)  $\frac{5}{16}$ "-18 x  $\frac{1}{2}$ " flange bolts, as shown in **Figure 17**.

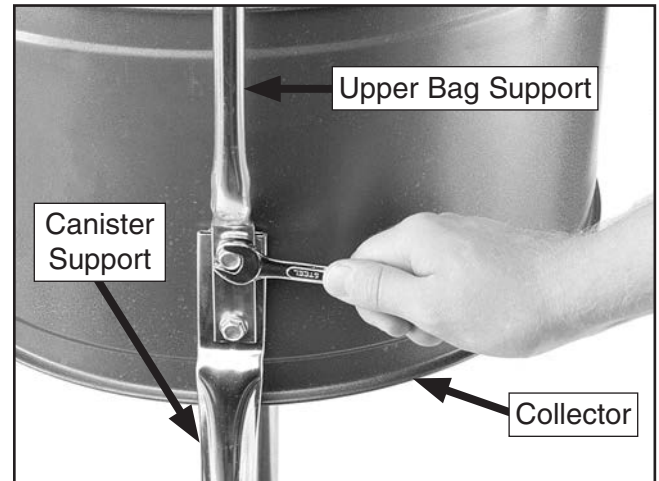

**Figure 17.** Mounting collector to brackets.

- Repeat **Steps 7 & 8** for the other collector. The assembly should now look similar to **Figure 18**.



**Figure 18.** Collectors installed (G0562Z shown).



10. Affix the wide foam strip around the outside top rim of the collector, as shown in **Figure 19**.



**Figure 19.** Installing wide foam strip.

11. Trim the excess foam strip so the ends come together evenly, as shown in **Figure 20**.



**Figure 20.** Trimmed foam strip.

12. Secure the narrow foam strip around the outside bottom rim of the collector and trim the excess, as shown in **Figure 21**.

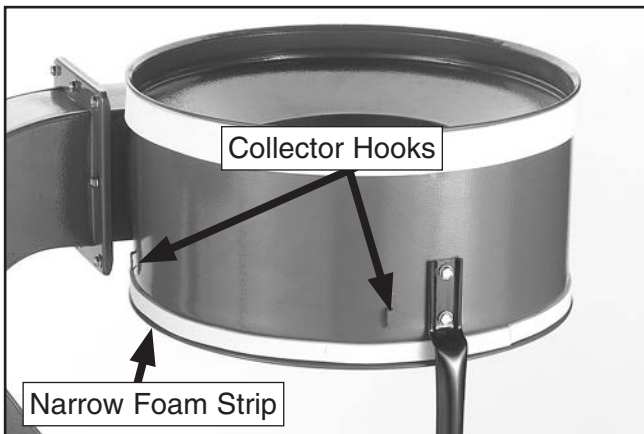

**Figure 21.** Trimmed foam strip and collector hook locations.

13. **G0562Z/G0562ZP only:**

- a. Install the canister handle onto the top of the canister filter by tightening the bolt against the flat of the shaft (see **Figure 22**).

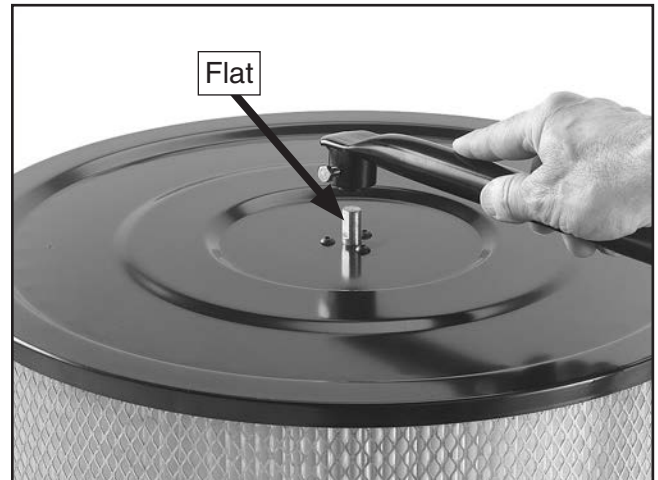

**Figure 22.** Installing canister handle.

- b. Place the canister filter on top of the collectors.
- c. Position the metal belt clamp around the bottom of the canister and latch it so it evenly compresses against the foam strip (see **Figure 17**).



**Figure 23.** Installed canister.

- d. Repeat a–c for the other canister.



**G1030Z2/G1030Z2P only:**

- a. Hook the top loop of the upper filter bags (fabric) over the upper bag supports, as shown in **Figure 24**.



**Figure 24.** Attaching upper filter bag.

- b. Tighten the upper bags to the collector using the strap and clamp kits shown in **Figure 25**.

**Note:** *DO NOT force the clamp. If it will not close, choose the next notch over, then clamp in place.*

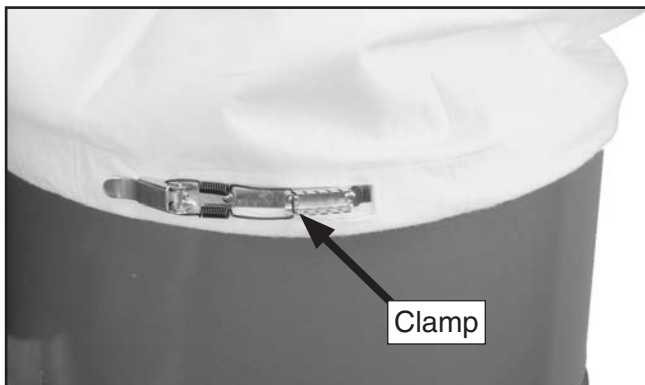

**Figure 25.** Upper collection bag secured.

- 14. Hook the clear collection bag on the hooks around the bottom of the collector to hold the bag in place for the next step.

- 15. Tighten the belt clamp around the narrow foam strip to seal and secure the lower collection bag (**Figure 26**).

**Note:** *DO NOT force the clamp. If it will not close, choose the next notch over, then clamp in place.*



**Figure 26.** Lower collection bag installed.

- 16. Insert the inlet over the impeller intake hole.

- 17. Secure the inlet in place with the Phillips head tap screw (**Figure 27**).



**Figure 27.** Installed inlet.



# Test Run

---

Once the assembly is complete, test run your machine to make sure it runs properly and is ready for regular operation.

The test run consists of verifying the following:  
1) The motor powers up and runs correctly, and  
2) the safety disabling mechanism on the switch works correctly.

If, during the test run, you cannot easily locate the source of an unusual noise or vibration, stop using the machine immediately, then review **Troubleshooting** on **Page 34**.

If you still cannot remedy a problem, contact our Tech Support at (570) 546-9663 for assistance.

## To test run the machine:

1. Make sure you have read the safety instructions at the beginning of the manual and that the machine is set up properly, as previously described in this manual.
2. Make sure all tools and objects used during setup are cleared away from the machine.
3. Verify that the machine is operating correctly by turning it **ON**.

—When operating correctly, the machine runs smoothly with little or no vibration or rubbing noises.

—Investigate and correct strange or unusual noises or vibrations before operating the machine further. Always disconnect the machine from power when investigating or correcting potential problems.

4. Turn the machine **OFF**.
5. Remove the switch disabling key, as shown in **Figure 28**.

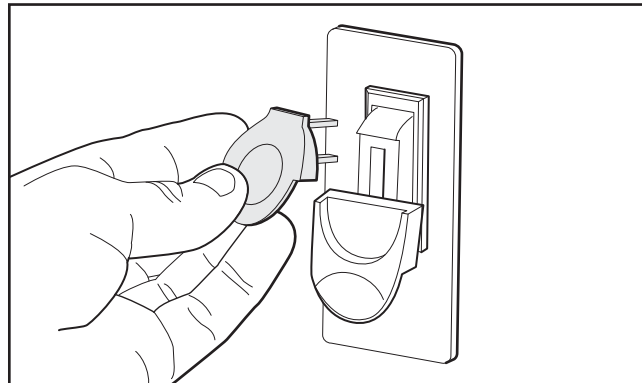

**Figure 28.** Removing switch key from paddle switch.

6. Try to start the machine with the paddle switch.
  - If the machine **does not** start, the switch disabling feature is working as designed.
  - If the machine **does** start, immediately stop the machine. The switch disabling feature is not working correctly. This safety feature must work properly before proceeding with regular operations. Call Tech Support for help.



# SECTION 4: DESIGNING THE SYSTEM

## General

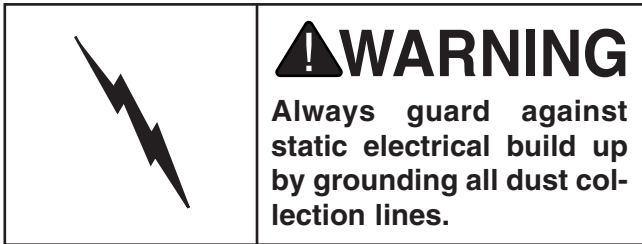

The Model G0562Z/G0562ZP and G1030Z2/G1030Z2P can be operated as either a stationary or a mobile unit. There are advantages and disadvantages to both set-ups. The advantage of the mobile system is eliminating the cost of many ducts and fittings. On the other hand, the stationary system is more versatile and convenient.

If using this machine as a central dust collector system, put the dust collector in an out of the way location such as a corner or separate room. The dust collector is capable of collecting dust from up to three machines running simultaneously. Grizzly offers a complete line of dust collection accessories for setting up a stationary system. Additionally, Grizzly offers a complete guide book entitled *Dust Collection Basics*.

Whatever system you choose, always make sure there are no open flames or pilot lights in the same room as the dust collector. There is a risk of explosion if dust is dispersed into the air.

## Duct Material

You have many choices regarding main line and branch line duct material. For best results, use metal duct for the main line and branch lines, then use short lengths of flexible hose to connect each machine to the branch lines.

Plastic duct is also a popular material for home shops. However, be aware that there is a fire or explosion hazard if plastic duct material is used for dust collection without being grounded against static electrical charge build-up. This topic will be discussed later in this section. Another problem with using plastic is that it is less efficient per foot than metal.

### Metal Duct

Advantages of metal duct is its conductivity and that it does not contribute to static electrical charge build-up. However, static charges are still produced when dust particles strike other dust particles as they move through the duct. Since metal duct is a conductor, it can be grounded quite easily to dissipate any static electrical charges.

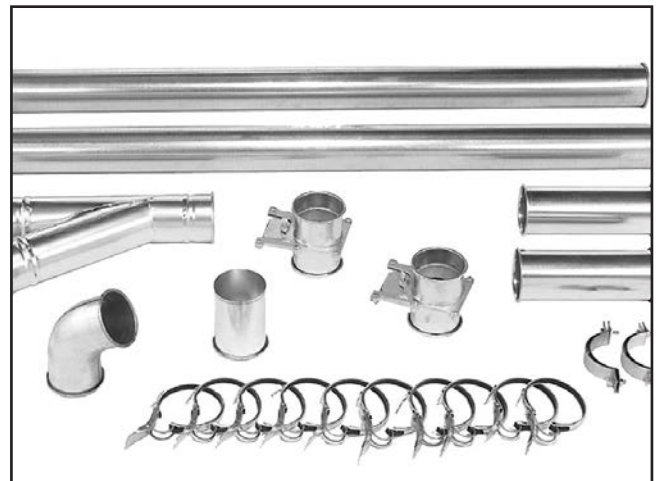

**Figure 29.** Examples of metal pipe and components.



There are a number of options when it comes to metal duct, but metal duct that is specially manufactured for dust collection is the best choice. When selecting your metal duct, choose high quality metal duct with smooth welded internal seams that will minimize airflow resistance. This type of duct usually connects to other ducts or elbows with a simple, self-sealing clamp, is very quick and easy to assemble, and can be readily dismantled and re-installed. This is especially important if you ever need to change things around in your shop or add more tools.

Avoid inferior metal duct that requires you to cut it to length and snap it together. This type of duct is time consuming to install because it requires you to seal all the seams with silicone and screw the components on the ends with sheet metal screws. Another disadvantage is the rough internal seams and crimped ends that unavoidably increase static pressure loss.

## Flexible Duct

Flexible hose is generally used for short runs, small shops, and at rigid duct-to-tool connections. There are many different types of flex hose on the market today. These are manufactured from materials such as polyethylene, PVC, cloth hose dipped in rubber, and even metal, including steel and aluminum.

The superior choice for flexible ducting is metal flex hose that is designed to be flexible and as smooth as possible to reduce static pressure loss. See **Page 29**.

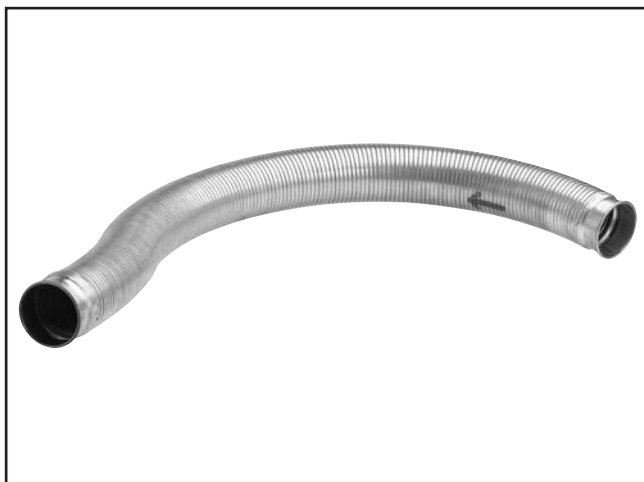

**Figure 30.** Example of flexible metal duct.

There are also many kinds of pure plastic flexible hose, such as non-perforated drainage type hose and dryer vent hose. Drainage type hose, while being economical, does not quite have the flexibility required for dust collection. The inside of the duct is also deeply corrugated and can increase the static pressure loss by as much as 50% over smooth wall duct. Dryer vent hose offers greater flexibility, but is non-resistant to abrasion and tends to collapse in a negative pressure system. We DO NOT recommend using dryer vent hose in your dust collection system.

If using flex-hose, choose one of the many types designed specifically for the movement of solid particles, i.e. dust, grains and plastics. However, the cost of specifically designed flexible duct can vary greatly. Grizzly offers polyethylene hose, which is well suited for the removal of particulate matter, especially sawdust, since it is durable and completely flexible. Polyethylene is also very economical and available in a wide variety of diameters and lengths for most applications.

## Plastic Duct

The popularity of plastic duct is due to the fact that it is economical and readily available. It is also simple to assemble and easily sealed against air loss. The primary disadvantage of plastic duct for dust collection is the inherent danger of static electrical build-up.



**Figure 31.** Example of plastic duct and components.



# System Design

## Step 1. Decide Who Will Design

For most small-to-medium sized shops, you can design and build the dust collection system yourself without hiring engineers or consultants. We have included some basic information here to get you started on a basic design.

If you have a large shop or end up designing a complicated system, then we recommend additional research beyond this manual, or that you seek the help of an expert.

## Step 2. Sketch Your Shop Layout

When designing a successful dust collection system, planning is the most important step. In this step, you must sketch a basic layout of your shop.

Before you get out your pencil and paper, we recommend you visit our **FREE Workshop Planner** available on our website at [www.grizzly.com](http://www.grizzly.com).

Our *Workshop Planner* will allow you to quickly and easily draw and print a basic shop layout. Don't worry, non-Grizzly brand machines can be substituted with Grizzly machines for layout purposes. **Note:** After you're finished, make sure to save your layout for later modification.

Your sketch only needs the basic details of the shop layout, similar to **Figure 32**, including all your current/planned machines and your planned placement of the dust collector.

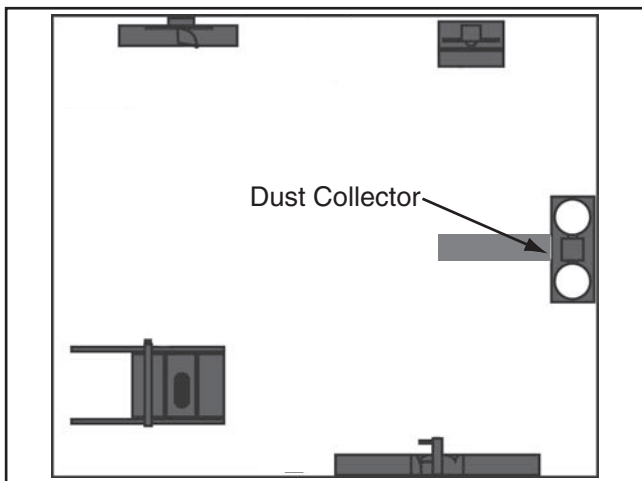
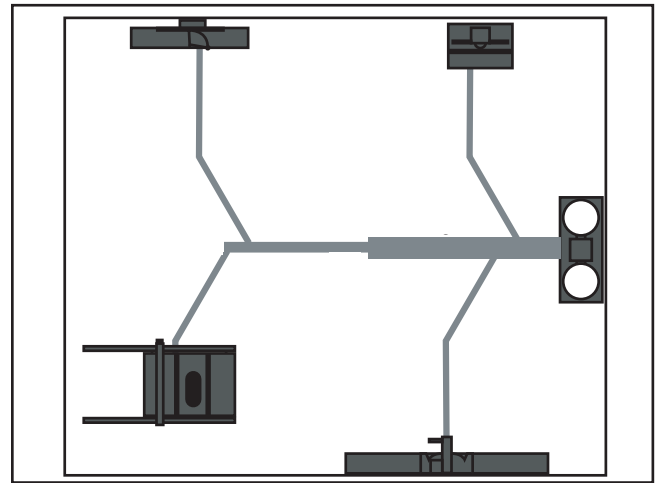

**Figure 32.** Basic sketch of shop layout.

## Step 3. Sketch a Basic Duct Layout

For the next step, sketch how you will connect your machines to the dust collector. Consider these general guidelines for an efficient system:

1. Machines that produce the most saw dust should be placed nearest to the dust collector (i.e. planers and sanders).
2. Ideally, you should design the duct system to have the shortest possible main line and secondary branch ducts. See **Figures 33 & 34** for ideas of good duct layouts vs bad duct layouts.



**Figure 33.** Good duct layout.

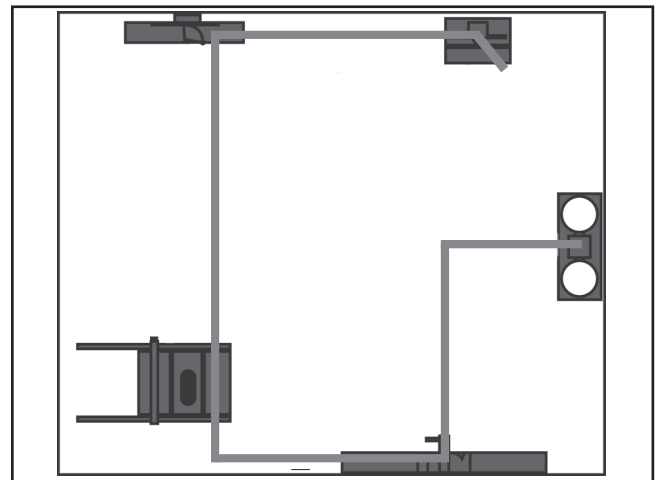

**Figure 34.** Bad duct layout.





3. Directional changes should be kept to a minimum. The more directional change fittings you use directly increases the overall resistance to airflow.
4. Gradual directional changes are more efficient than sudden directional changes (i.e. use the largest corner radius possible when changing hose or pipe direction).
5. Each individual branch line should have a blast gate immediately after the branch to control suction from one machine to another.
6. The simpler the system, the more efficient and less costly it will be.

### Step 4. Determine Required CFM of Each Machine

Since each machine produces a different amount of sawdust, the requirements for the minimum amount of CFM to move that sawdust is unique to the machine (for example, a planer produces more sawdust than a table saw). Knowing this required CFM is important to gauging which size of duct to use.

**Figure 35** gives you a close estimation of the airflow your machine requires. Keep in mind that machines that generate the most sawdust should be placed closest to the dust collector. If the machine has multiple dust ports, the total CFM required is the sum of all ports.

Machine Dust Port Size	Approximate Required CFM
2"	98
2.5"	150
3"	220
4"	395
5"	614
6"	884
7"	1203
8"	1570
9"	1990
10"	2456

**Figure 35.** Approximate required airflow for machines, based on dust port size.

If the machine doesn't have a built-in dust port, use **Figure 36** to determine which size of dust port to install.

Machine	Average Dust Port Size
Table Saw.....	4"
Miter/Radial-Arm Saw.....	2"
Jointer (6" and smaller) .....	4"
Jointer (8"-12") .....	5"
Thickness Planer (13" and smaller).....	4"
Thickness Planer (14"-20") .....	6"
Shaper.....	4"
Router (mounted to table).....	2"
Bandsaw.....	4"
Lathe.....	4"
Disc Sander (12" and smaller).....	2"
Disc Sander (13-18").....	4"
Belt Sander (6" and smaller) .....	2"
Belt Sander (7"-9") .....	3"
Edge Sander (6" x 80" and smaller).....	4"
Edge Sander (6" x 80" and larger) .....	5"
Drum Sander (24" and smaller).....	2 x 4"
Drum Sander (24" and larger) .....	4 x 4"
Widebelt Sander (18" and smaller).....	5"
Widebelt Sander (24"-37" single head) ..	2 x 6"
Widebelt Sander (24" _51" double head) ..	.5 x 4"

**Figure 36.** Dust port size and quantity per average machine.

Write the required CFM for each machine on your sketch, as shown in **Figure 37**.

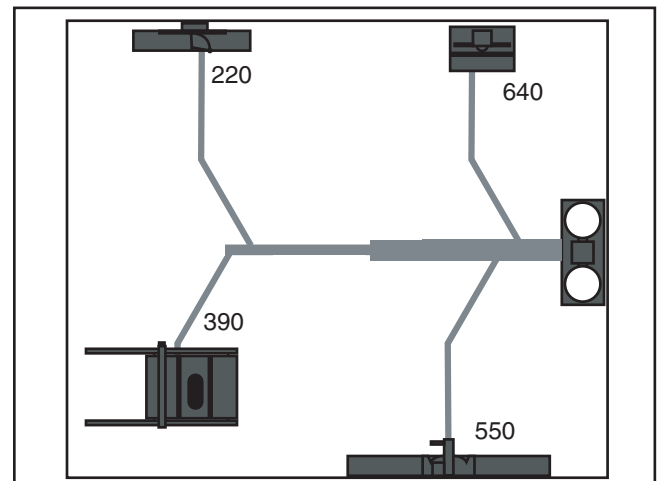

**Figure 37.** CFM requirements labeled for each machine.



## Determining Main Line Duct Size

The general rule of thumb for a main line duct is that the velocity of the airflow must not fall below 3500 FPM.

For small/medium sized shops, using the inlet size of the dust collector as the main line duct size will usually keep the air velocity above 3500 FPM and, depending on your system, will allow you to keep multiple branches open at one time.

Mark your drawing as in **Figure 38**, but using the inlet size for your dust collector as the main line.

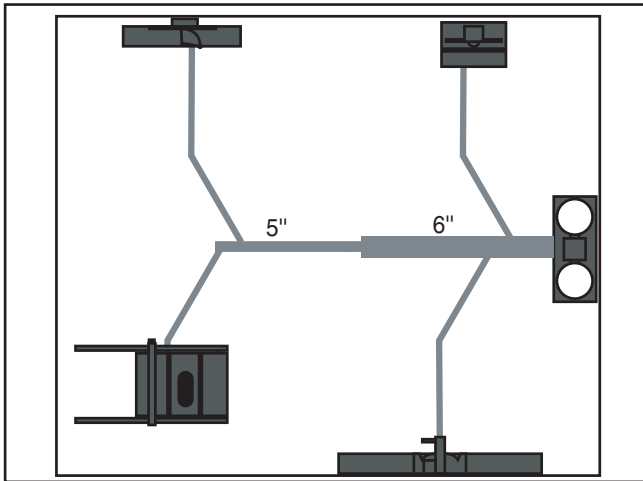

**Figure 38.** Main line size labeled on sketch.

## Determining Branch Line Duct Size

The general rule of thumb for a branch line duct is that the velocity of the airflow must not fall below 4000 FPM.

For small/medium sized shops, using the dust port size from the machine as the branch line duct size will achieve the correct velocity in most applications. However, if the dust port on the machine is smaller than 4", make the branch line 4" and neck the line down right before the dust port.

**Note:** *Systems with powerful dust collectors work better if multiple blast gates are left open. This also allows you to run two machines at once. Experiment with different combinations of blast gates open/closed to find the best results for your system.*

Write your determined branch line sizes on your drawing, as shown in **Figure 39**.

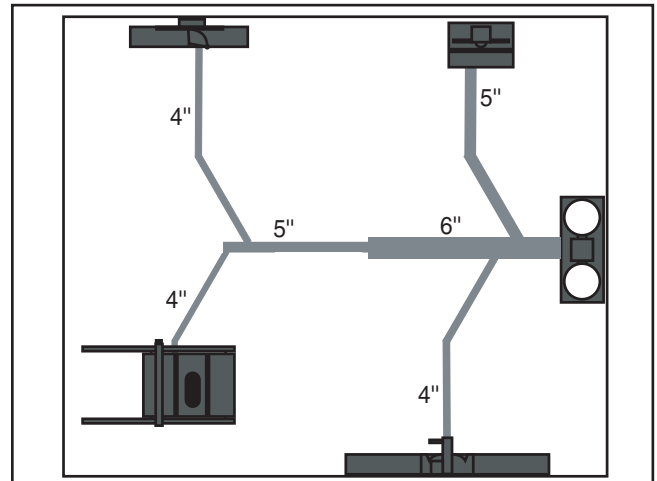

**Figure 39.** Branch line sizes labeled on sketch.

Here are some frequently asked questions when determining branch line sizes:

**How do I figure which size of branch line to use if the machine has two dust ports?**

Simply add the total CFM given for each size from **Figure 35** and refer that CFM number to **Figure 40**. Then, split the branch line just before the dust ports with matching duct sizes.

**What if two machines share the same branch line?** You have two options:

1. If both machines will be running at the same time, add the total CFM given for each size from **Figure 35** and match the branch line given in **Figure 40**.
2. If both the machines will never be run at the same time, reference the machine with biggest dust port to **Figure 40** and add blast gates after the Y-branch to open/close the line to each machine.

Total CFM	Branch Line Size
400	4"
500	4"
600	5"
700	5"
800	6"
900	6"
1000	6"

**Figure 40.** Branch line sizing chart by total CFM (for use when multiple machines share line).



## Calculating Duct Resistance

Adding duct work, elbows, branches and any other components to a duct line increases airflow resistance (static pressure loss). This resistance can be minimized by using rigid (smooth) pipe and gradual curves, as opposed to flexible pipe and 90° elbows.

To help you think about this resistance, imagine riding a bicycle in a tunnel that is an exact replica of your duct work. If the inside of the tunnel is very bumpy (flexible pipe) and has a lot of sharp turns (90° elbows), it will take a lot more effort to travel from one end to the other.

The purpose of calculating the resistance is to determine if it is low enough from the machine to the dust collector to meet the given CFM requirement for the machine. Use the charts in **Figure 41** to calculate the resistance of duct work.

Duct Dia.	Approximate Static Pressure Loss Per Foot of Rigid Pipe		Approximate Static Pressure Loss Per Foot of Flex Pipe	
	Main Lines at 3500 FPM	Branch Lines at 4000 FPM	Main Lines at 3500 FPM	Branch Lines at 4000 FPM
2"	0.091	0.122	0.35	0.453
2.5"	0.08	0.107	0.306	0.397
3"	0.071	0.094	0.271	0.352
4"	0.057	0.075	0.215	0.28
5"	0.046	0.059	0.172	0.225
6"	0.037	0.047	0.136	0.18
7"	0.029	0.036	0.106	0.141
8"	0.023	0.027	0.08	0.108
9"	0.017	0.019	0.057	0.079

Fitting Dia.	90° Elbow	45° Elbow	45° Wye(Y)	90° Wye(Y)
3"	0.47	0.235	0.282	0.188
4"	0.45	0.225	0.375	0.225
5"	0.531	0.266	0.354	0.236
6"	0.564	0.282	0.329	0.235
7"	0.468	0.234	0.324	0.216
8"	0.405	0.203	0.297	0.189

**Figure 41.** Static pressure loss charts.

In most small/medium shops it is only necessary to calculate the line with the longest duct length or the most fittings (operating under the assumption that if the line with the highest resistance works, the others will be fine).

**To calculate the static pressure of any given line in the system, follow these steps:**

1. Make a list of each size duct in the line, including the length, and multiply those numbers by the static pressure value given in **Figure 41**.
2. List each type of elbow or branch and multiply the quantity (if more than one) by the static pressure loss given in **Figure 41**.
3. Add the additional factors from **Figure 42** to your list.

Additional Factors	Static Pressure
Seasoned (well used) Dust Collection Filter	1"
Entry Loss at Large Machine Hood	2"

**Figure 42.** Additional factors affecting static pressure.

4. Total your list as shown in the example in **Figure 43** to come up with your overall static pressure loss number for that line.

**Note:** Always account for a seasoned filter, so you don't end up with a system that only works right when the filter is clean.

<b>Main Line</b>	
6" Rigid Pipe (0.037) at 20'	0.740
<b>Branch Line</b>	
4" Rigid Pipe (0.075) at 10'	0.750
4" Flex Pipe (0.28) at 5'	1.400
<b>Elbows/Branches</b>	
6" 45° Y-Branch	0.329
4" 45° Elbow	0.225
<b>Additional Factors</b>	
Seasoned Filter	1.000
<b>Total Static Pressure Loss</b>	<b>4.444</b>

**Figure 43.** Totaling static pressure numbers.



**Note:** When calculating static pressure loss to determine if multiple lines can be left open at the same time, only include the main line numbers once.

5. Compare the total static pressure loss for that line to the maximum static pressure loss found on the data sheet for your machine (located toward the front of this manual).

—If the CFM for your static pressure loss is above the requirement of the machine, then the line will most likely be successful. Congratulations! You've just designed your own dust system. Refer to **Page 30** to start buying the components necessary to make your system a reality.

—If the CFM for your static pressure loss is below the requirement of the machine, then that line will not effectively collect the dust. You must then modify some of the factors in that line to reduce the static pressure loss. Some of the ways to do this include 1) installing larger duct, 2) reducing amount of flexible duct used, 3) increasing machine dust port size, 4) moving machine closer to dust collector to eliminate duct length, and 5) reducing 90° elbows or replacing them with 45° elbows.

## System Grounding

Since plastic hose is abundant, relatively inexpensive, easily assembled and air tight, it is a very popular material for conveying dust from woodworking machines to the dust collector. We recommend using flexible hose (flex-hose) to connect the woodworking machine to the dust collector. However, plastic flex-hose and plastic duct are an insulator, and dust particles moving against the walls of the plastic duct create a static electrical build up. This charge will build until it discharges to a ground. If a grounding medium is not available to prevent static electrical build up, the electrical charge will arc to the nearest grounded source. This electrical discharge may cause an explosion and subsequent fire inside the system.

To protect against static electrical build up inside a non-conducting duct, a bare copper wire should be placed inside the duct along its length and grounded to the dust collector. You must also confirm that the dust collector is continuously grounded through the electrical circuit to the electric service panel.

If you connect the dust collector to more than one machine by way of a non-conducting branching duct system and blast gates, the system must still be grounded as mentioned above. We recommend inserting a continuous bare copper ground wire inside the entire duct system and attaching the wire to each grounded woodworking machine and dust collector.

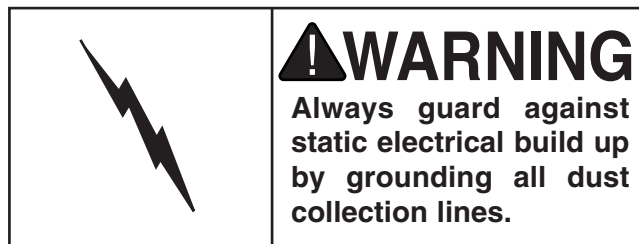

Be sure that you extend the bare copper wire down all branches of the system. Do not forget to connect the wires to each other with wire nuts when two branches meet at a “Y” or “T” connection.

Ensure that the entire system is grounded. If using plastic blast gates to direct air flow, the grounding wire must be jumped (**Figure 44**) around the blast gate without interruption to the grounding system.

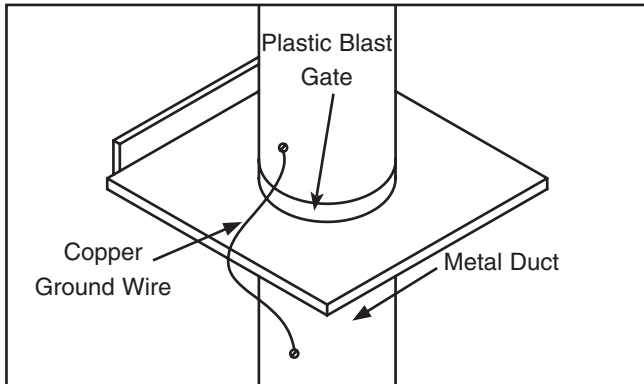

**Figure 44.** Ground jumper wire when using plastic blast gates and metal duct.

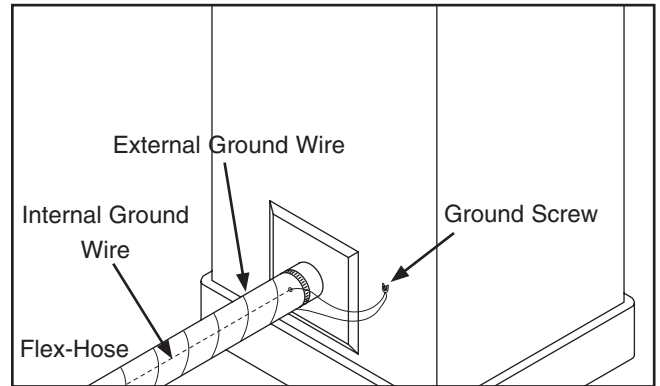

**Figure 45.** Flex-hose grounded to machine.

We also recommend wrapping the outside of all plastic ducts with bare copper wire to ground the outside of the system against static electrical build up. Wire connections at Y's and T's should be made with wire nuts.

Attach the bare ground wire to each stationary woodworking machine and attach to the dust collector frame with a ground screw as shown in **Figure 45**. Ensure that each machine is continuously grounded to the grounding terminal in your electric service panel.

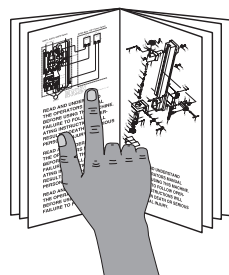

# SECTION 5: OPERATIONS

	<p><b>⚠ WARNING</b></p> <p>To reduce the risk of serious injury when using this machine, read and understand this entire manual before beginning any operations.</p>
---	--

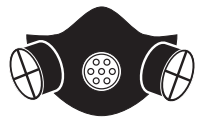
<p><b>⚠ WARNING</b></p> <p>Damage to your eyes and lungs could result from using this machine without proper protective gear. Always wear safety glasses and a respirator when operating this machine.</p>	
	

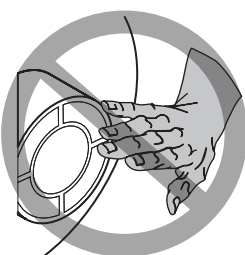
	<p><b>⚠ WARNING</b></p> <p>Do NOT put hands or small objects near inlet openings during operation. Objects sucked into the inlet will meet with the impeller blade. Failure to heed this warning could result in property damage or personal injury.</p>
---	--

<p><b>NOTICE</b></p> <p>If you have never used this type of machine or equipment before, WE STRONGLY RECOMMEND that you read books, trade magazines, or get formal training before beginning any projects. Regardless of the content in this section, Grizzly Industrial will not be held liable for accidents caused by lack of training.</p>
--

## General

Operating the Model G0562Z/G0562ZP/G1030Z2/G1030Z2P is simple and straightforward. Turn the dust collector **ON**, then turn the machine **ON**. When you are finished with the machine operation, turn **OFF** the machine, then turn **OFF** the dust collector.

Blast gates can be used at the start of each branch line to control the air flow from the woodworking machine to the dust collector. If a machine is not being used, keep the blast gate closed to maintain higher levels of efficiency throughout the system.

## Machine Storage

When the dust collector is not in use, unplug the power cord from the power source. Place the cord away from potential damage sources, such as high traffic areas, sharp objects, heat sources, harsh chemicals, water, damp areas, etc.



# SECTION 6: ACCESSORIES

## ⚠️ WARNING

Some aftermarket accessories can be installed on this machine that could cause it to function improperly, increasing the risk of serious personal injury. To minimize this risk, only install accessories recommended for this machine by Grizzly.

## NOTICE

Refer to the newest copy of the Grizzly Catalog for other accessories available for this machine.

Call 1-800-523-4777 To Order

### T20543— Plastic Bottom Bag

This 41" x 31" Flat (19.75" Diameter) Plastic Bottom Bag is for the G0525, G0548/Z/ZP, G0562/Z/ZP, G1029/Z2/Z2P, G1030Z/Z2/Z2P, and G1028Z/Z2 Dust Collectors.

### H5783—Extra 1 Micron Canister

Replacement canister for Grizzly G0548Z/ G0548ZP, G0562Z/G0562ZP, G1028Z/Z2, G1029Z/Z2/Z2P, and G1030Z/Z2/Z2P Dust Collectors.



Figure 46. Replacement canister.

### G1536—Black Flexible Hose 4" x 10'

### G2974—Wire Hose Clamp 4"

### G1843—Plastic Blast Gate 4"

### G4679—Anti-Static Grounding Kit

We've hand picked a selection of commonly used dust collection components for machines with 4" dust ports.

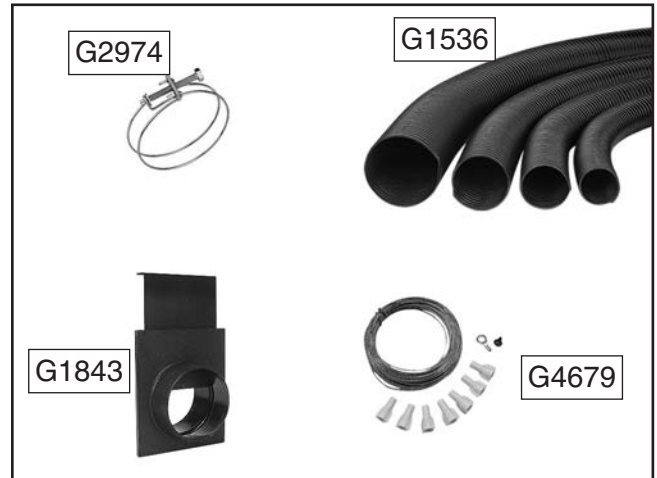

Figure 47. 4" dust collection accessories.

### G9956—Remote Controlled Heavy-Duty Double Air Filter

### G0572—Hanging Air Filter with Remote

These Hanging Air Filters have convenient remote controls and feature a three speed motor, automatic shutoff timer and hang easily from the workshop ceiling.



Figure 48. G0572 Dust Filter.



**H5293—4" Metal Duct Starter Kit**

**H5295—5" Metal Duct Starter Kit**

**H5297—6" Metal Duct Starter Kit**

Save over 20% with this great starter kit. Includes: (2) machine adapters, (10) pipe clamps, (3) 5' straight pipes, (1) branch, (3) pipe hangers, (1) end cap, (3) adjustable nipples, (1) 90° elbow, and (1) 60° elbow.

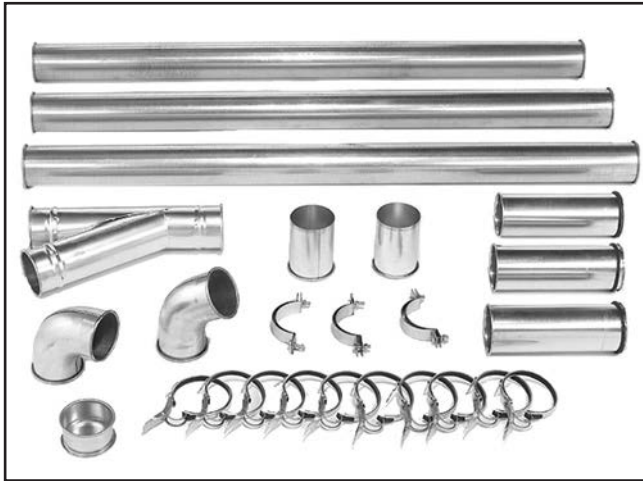

**Figure 49.** Metal Duct Starter Kit.

**H5294—4" Metal Duct Machine Addition Kit**

**H5296—5" Metal Duct Machine Addition Kit**

**H5298—6" Metal Duct Machine Addition Kit**

Save over 20% with this great machine addition kit. Includes: (2) blast gates, (1) machine adapter, (10) pipe clamps, (2) pipe hangers, (2) 5' straight pipes, (2) adjustable nipples, (1) branch, and (1) 60° elbow.

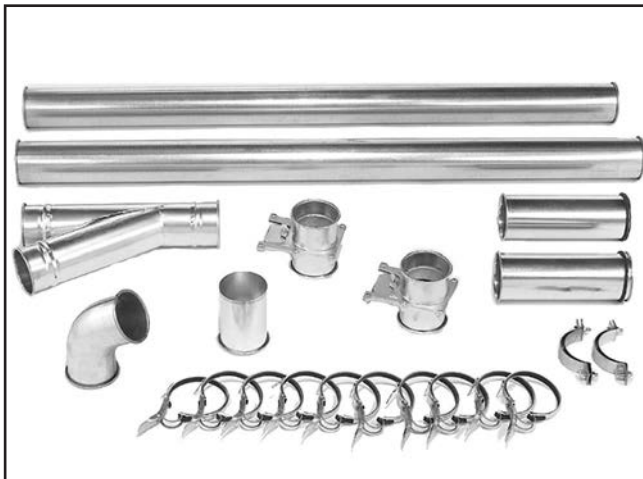

**Figure 50.** Metal Duct Machine Addition Kit.

**G6162—4" x 5' Straight Metal Pipe**

**G7346—5" x 5' Straight Metal Pipe**

**G7364—6" x 5' Straight Metal Pipe**

These laser welded straight pipes ensure a super smooth internal seam. Ends easily clamp together for a sealed fit without screws or silicone.



**Figure 51.** Straight Metal Pipe.

**H7215—4" x 5' Rigid Metal Flex Hose**

**H7216—5" x 5' Rigid Metal Flex Hose**

**H7217—6" x 5' Rigid Metal Flex Hose**

This flex hose provides just enough flexibility to make difficult connections while still keeping the inside wall as smooth as possible to minimize static pressure loss.

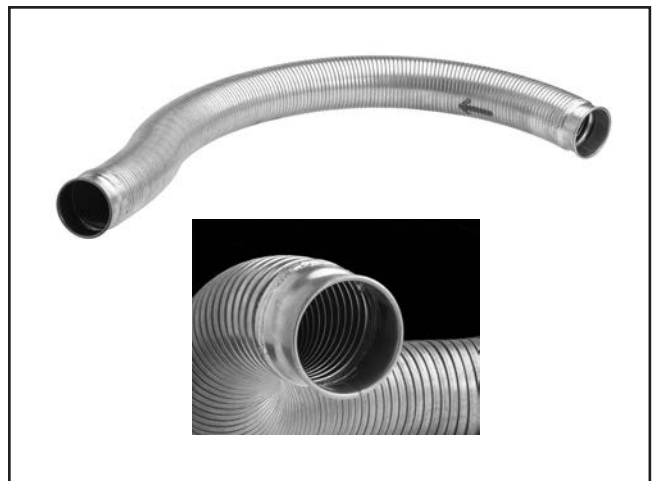

**Figure 52.** Rigid Metal Flex Hose.

**Call 1-800-523-4777 To Order**





### Metal Branches

We carry many different branches, all designed to minimize airflow resistance.



Figure 53. Metal Branches.

### Reducers & Adapters

We carry a multitude of reducers and elbows to cover most applications from 4" through 9".



Figure 54. Metal Reducers & Adapters.

### Metal Elbows

These industrial metal elbows are available from 4"–8" with 90°, 60°, 45°, or 30° curves. Call (800) 523-4777 or visit [www.grizzly.com](http://www.grizzly.com) for more information and pricing.

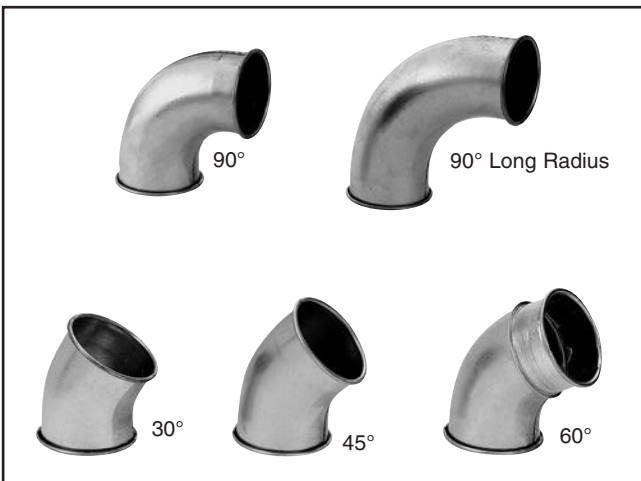

Figure 55. Metal elbow examples.

- H2499—Small Half-Mask Respirator
- H3631—Medium Half-Mask Respirator
- H3632—Large Half-Mask Respirator
- H3635—Cartridge Filter Pair P100

Wood dust has been linked to nasal cancer and severe respiratory illnesses. If you work around wood dust everyday, a half-mask respirator can be a lifesaver. Also compatible with safety glasses!



Figure 56. Half-mask respirator with disposable cartridge filters.

### Basic Eye Protection

- T20501—Face Shield Crown Protector 4"
- T20502—Face Shield Crown Protector 7"
- T20503—Face Shield Window
- T20451—"Kirova" Clear Safety Glasses
- T20452—"Kirova" Anti-Reflective S. Glasses
- H7194—Bifocal Safety Glasses 1.5
- H7195—Bifocal Safety Glasses 2.0
- H7196—Bifocal Safety Glasses 2.5



Figure 57. Eye protection assortment.

Call 1-800-523-4777 To Order



# SECTION 7: MAINTENANCE

---

---



## Schedule

---

For optimum performance from your machine, follow this maintenance schedule and refer to any specific instructions given in this section.

### Daily Check:

- Loose mounting bolts.
- Worn switch.
- Worn or damaged wires.
- Almost full collection bag.
- Any other unsafe condition.

## Lubrication

---

Since all bearings are shielded and permanently lubricated, simply leave them alone until they need to be replaced. Do not lubricate them.

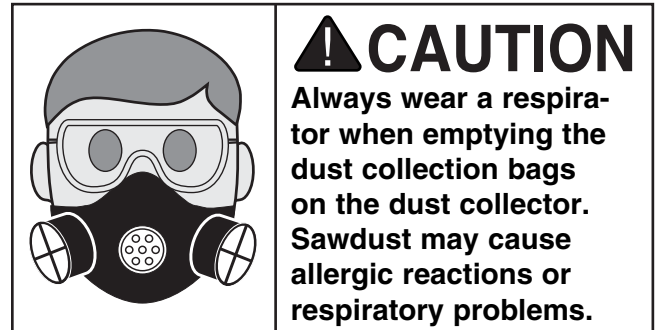

## Bag Cleaning

---

Always empty the collection bags on a regular basis. Emptying the collection bags allows the machine to operate at a much higher level of efficiency.

Always wear the appropriate respirator or dust mask and safety glasses when emptying the collection bags. Small dust particles can escape the bags during emptying, causing them to become airborne and easily inhaled. This microscopic airborne dust is extremely unhealthy to breathe and can cause serious health problems.

While the Model G0562Z/G0562ZP/G1030Z2/G1030Z2P excels at collecting the majority of wood dust produced by your machines, it is not an air filter; therefore, **we strongly recommend** the supplemental aid of a shop air filter such as the Grizzly G0572 or G9956. Air filters are designed to collect the smaller dust particles in the air that escape from the dust collector bags.



# Emptying/Replacing Bags

Replacement plastic lower collection bags are available through Grizzly as Model T20543. Replacement upper collection bags are available for the Model G1030Z2/G1030Z2P as Model G5556.

## To replace the collection bag:

1. DISCONNECT MACHINE FROM POWER!
2. Make sure you are wearing safety glasses and a respirator.
3. Release the belt clamp securing the collection bag, then unhook the bag from the collector.
4. Securely close the top of the bag and safely dispose of it according to local and federal standards.
5. Install a new collection bag.

# Cleaning Canister Filter

To clean the canister filter on the Model G0562Z/G0562ZP, move the canister cleaning handle back and forth to free the trapped dust particles from the filter pleats (see **Figure 58**). The particles will fall into the collection bag.

The replacement canister for the G0562Z/G0562ZP is the Model H5783, which can also be installed on the G1030Z2/G1030Z2P.



**Figure 58.** Canister cleaning handle directions.

## **NOTICE**

The use of compressed air or liquids to clean the canister filter will damage the filtration pleats of the filter. Use **ONLY** the cleaning handle or, if necessary, a soft brush to clean the inside of the canister filter.



# SECTION 8: SERVICE

Review the troubleshooting and procedures in this section if a problem develops with your machine. If you need replacement parts or additional help with a procedure, call our Technical Support at (570) 546-9663.

**Note:** Please gather the serial number and manufacture date of your machine before calling.

To reduce the risk of serious personal injury or damage to the machine, any repairs not covered in this manual should only be performed by or with the assistance of qualified service personnel.

## Troubleshooting

### Motor & Electrical

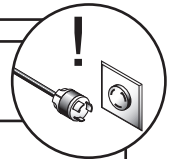

Symptom	Possible Cause	Possible Solution
Machine does not start or a breaker trips.	<ol style="list-style-type: none"> <li>1. Switch disabling key removed.</li> <li>2. Power supply switched OFF or is at fault.</li> <li>3. Wall fuse/circuit breaker is blown/tripped.</li> <li>4. Wiring is open/has high resistance.</li> <li>5. Motor ON button or ON/OFF switch is at fault.</li> <li>6. Motor is at fault.</li> </ol>	<ol style="list-style-type: none"> <li>1. Install switch disabling key.</li> <li>2. Ensure power supply is switched on; ensure power supply has the correct voltage.</li> <li>3. Ensure circuit size is suitable for this machine; replace weak breaker.</li> <li>4. Check for broken wires or disconnected/corroded connections, and repair/replace as necessary.</li> <li>5. Replace faulty ON button or ON/OFF switch.</li> <li>6. Test/repair/replace.</li> </ol>
Machine has vibration or noisy operation.	<ol style="list-style-type: none"> <li>1. Motor, motor mount, or other mounting component is loose or broken.</li> <li>2. Machine is incorrectly mounted or sits unevenly.</li> <li>3. Motor fan is rubbing on fan cover.</li> <li>4. Impeller is loose or damaged and unbalanced.</li> <li>5. Motor bearings are at fault.</li> </ol>	<ol style="list-style-type: none"> <li>1. Retighten. Use thread locking fluid if necessary. Replace stripped fasteners or damaged components if necessary.</li> <li>2. Tighten/replace anchor studs in floor if mounted; chock machine casters if mobile.</li> <li>3. Replace dented fan cover; replace loose/damaged fan.</li> <li>4. Disconnect dust collector from power, and inspect the impeller for dents, bends, loose fins. Replace the motor and impeller as a set if the motor shaft and the impeller hub are damaged.</li> <li>5. Test by rotating shaft; rotational grinding/loose shaft requires bearing replacement.</li> </ol>

Continued on next page →



## Dust Collector Operation

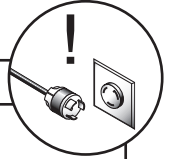

Symptom	Possible Cause	Possible Solution
Dust collector does not adequately collect dust or chips; poor performance.	<ol style="list-style-type: none"> <li>1. Dust collection bags are full.</li> <li>2. Filter is dirty.</li> <li>3. Restriction in duct line.</li> <li>4. Dust collector is too far away, or there are too many sharp bends in the ducting.</li> <li>5. Lumber is wet and dust not flowing through ducting smoothly.</li> <li>6. Leaks in ducting or too many open ports.</li> <li>7. Not enough open branch lines, causing a velocity drop in the main line.</li> <li>8. Ducting or machine dust ports are incorrectly sized.</li> <li>9. The machine dust collection design is inadequate.</li> <li>10. The dust collector is too small for the dust collection system, or ducting layout design inadequate.</li> </ol>	<ol style="list-style-type: none"> <li>1. Empty collection bags.</li> <li>2. Clean filter.</li> <li>3. Remove restriction in the duct line. A plumbing snake may be necessary.</li> <li>4. Relocate the dust collector closer to the point of suction, and rework ducting without sharp bends. Refer to <b>System Design</b>, beginning on <b>Page 22</b>.</li> <li>5. Process lumber with less than 20% moisture content.</li> <li>6. Rework the ducting to eliminate all leaks. Close dust ports for lines not being used.</li> <li>7. Open 1 or 2 more blast gates to different branch lines to allow the velocity in the main line to increase.</li> <li>8. Re-install correctly sized ducts and fittings. Refer to <b>System Design</b> beginning on <b>Page 22</b> for more solutions.</li> <li>9. Use a dust collection nozzle on a stand.</li> <li>10. Install a larger dust collector to power your dust collection system.</li> </ol>
Sawdust being blown into the air from the dust collector.	<ol style="list-style-type: none"> <li>1. Duct clamps or dust collection bags are not properly clamped and secured.</li> <li>2. Bag clamps are loose or damaged.</li> </ol>	<ol style="list-style-type: none"> <li>1. Re-secure ducts and dust collection bag, making sure duct and bag clamps are tight and completely over the ducts and bags.</li> <li>2. Retighten bag clamps.</li> </ol>



# SECTION 9: WIRING

These pages are current at the time of printing. However, in the spirit of improvement, we may make changes to the electrical systems of future machines. Compare the manufacture date of your machine to the one stated in this manual, and study this section carefully.

If there are differences between your machine and what is shown in this section, call Technical Support at (570) 546-9663 for assistance BEFORE making any changes to the wiring on your machine. An updated wiring diagram may be available. **Note:** *Please gather the serial number and manufacture date of your machine before calling. This information can be found on the main machine label.*

## WARNING

### Wiring Safety Instructions

**SHOCK HAZARD.** Working on wiring that is connected to a power source is extremely dangerous. Touching electrified parts will result in personal injury including but not limited to severe burns, electrocution, or death. Disconnect the power from the machine before servicing electrical components!

**MODIFICATIONS.** Modifying the wiring beyond what is shown in the diagram may lead to unpredictable results, including serious injury or fire. This includes the installation of unapproved after-market parts.

**WIRE CONNECTIONS.** All connections must be tight to prevent wires from loosening during machine operation. Double-check all wires disconnected or connected during any wiring task to ensure tight connections.

**CIRCUIT REQUIREMENTS.** You MUST follow the requirements at the beginning of this manual when connecting your machine to a power source.

**WIRE/COMPONENT DAMAGE.** Damaged wires or components increase the risk of serious personal injury, fire, or machine damage. If you notice that any wires or components are damaged while performing a wiring task, replace those wires or components.

**MOTOR WIRING.** The motor wiring shown in these diagrams is current at the time of printing but may not match your machine. If you find this to be the case, use the wiring diagram inside the motor junction box.















**CAPACITORS/INVERTERS.** Some capacitors and power inverters store an electrical charge for up to 10 minutes after being disconnected from the power source. To reduce the risk of being shocked, wait at least this long before working on capacitors.

**EXPERIENCING DIFFICULTIES.** If you are experiencing difficulties understanding the information included in this section, contact our Technical Support at (570) 546-9663.

#### NOTICE

The photos and diagrams included in this section are best viewed in color. You can view these pages in color at [www.grizzly.com](http://www.grizzly.com).

#### COLOR KEY

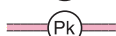
BLACK		BLUE		YELLOW		LIGHT BLUE	
WHITE		BROWN		YELLOW GREEN		BLUE WHITE	
GREEN		GRAY		PURPLE		TURQUOISE	
RED		ORANGE		PINK			



# Wiring Diagram

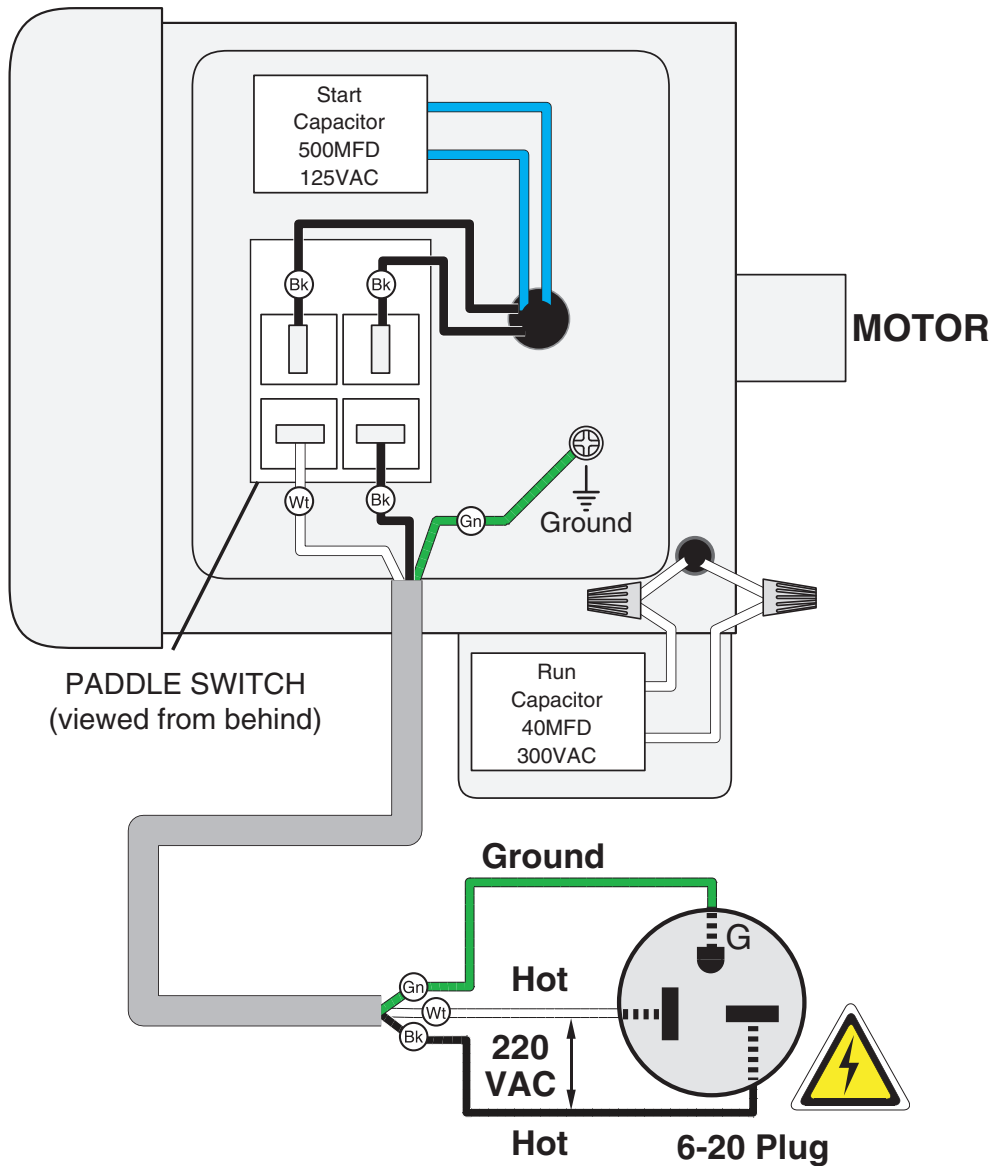

Figure 59. Switch.



Figure 60. Junction box and start capacitor.

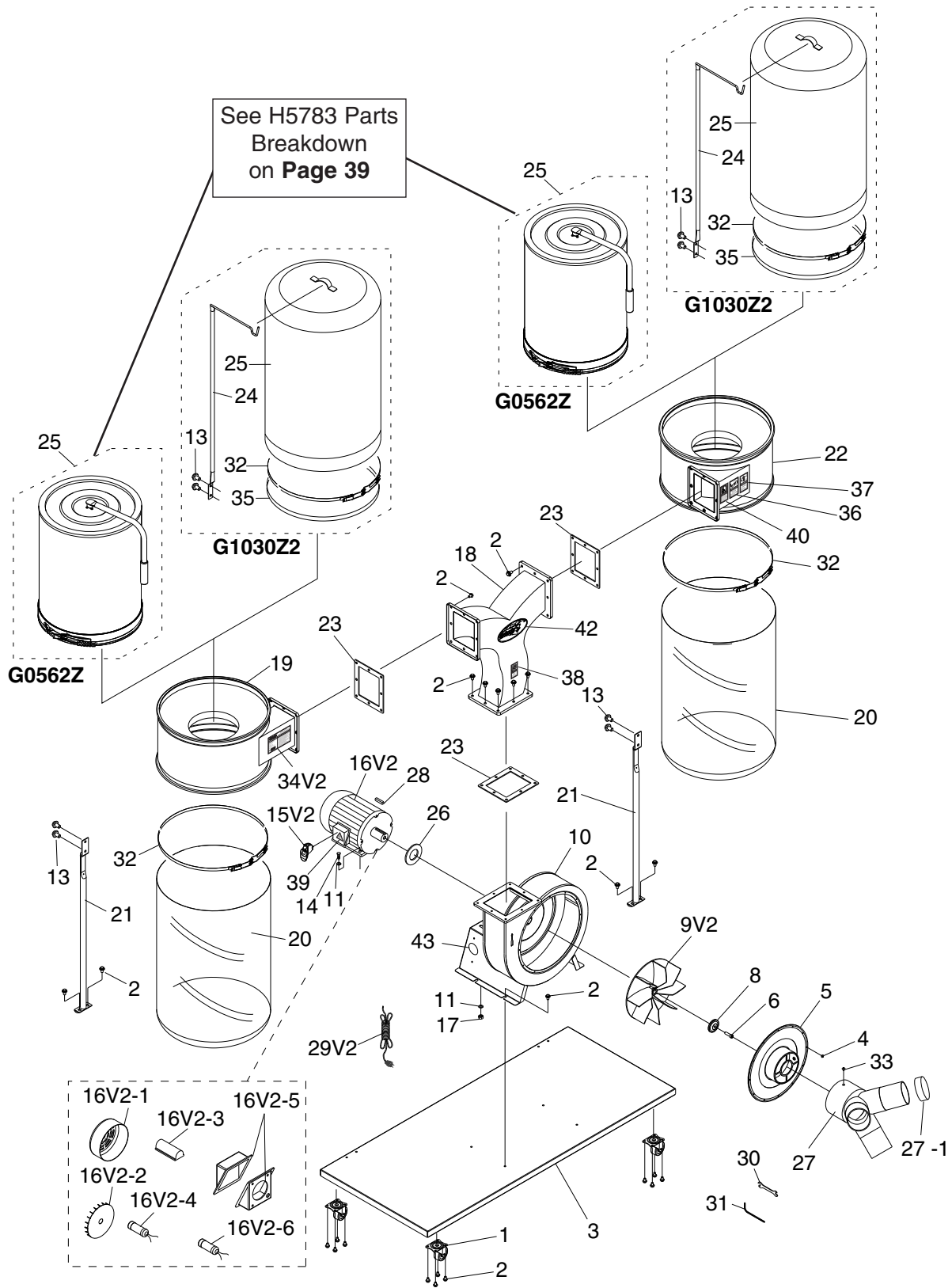

Figure 61. Run capacitor.



# SECTION 10: PARTS

## G0562Z/G1030Z2 Main Breakdown





# G0562Z/G1030Z2 Main Parts List

REF	PART #	DESCRIPTION
1	P1028Z2001	CASTER
2	PFB01	FLANGE BOLT 5/16-18 X 1/2
3	P1030Z2003	BASE PLATE
4	PS06	PHLP HD SCREW 10-24 X 3/8"
5	P1030Z2005	INLET COVER 7"
6	PCAP121M	CAP SCREW M6-1 X 20 LH
8	P1028Z2009	IMPELLER WASHER
9V2	P1029Z2010V2	IMPELLER 12-3/4" ALUM V2.09.11
10	P1028Z2011	COLLECTOR BODY
11	PW07	FLAT WASHER 5/16
13	PFB01	FLANGE BOLT 5/16-18 X 1/2
14	PB03	HEX BOLT 5/16-18 X 1
15V2	P1030Z2015V2	PADDLE SWITCH V2.09.11
16V2	P1030Z2016V2	MOTOR 3HP 220V 1PH V2.09.11
16V2-1	P1030016-1	MOTOR FAN COVER
16V2-2	P1030016-2	MOTOR FAN
16V2-3	P1030Z2016V2-3	CAPACITOR COVER V2.09.11
16V2-4	P1030Z2016V2-4	S CAPACITOR 500M 125V V2.09.11
16V2-5	P1030Z2016V2-5	JUNCTION BOX V2.09.11
16V2-6	P1030Z2016V2-6	R CAPACITOR 40M 300V V2.09.11
17	PN02	HEX NUT 5/16-18
18	P1030018	METAL "Y" OUTLET
19	P1030019	LEFT COLLECTOR
20	T20543	LOWER DUST COLLECTOR BAG
21	P1028Z2023	COLLECTOR SUPPORT

REF	PART #	DESCRIPTION
22	P0548Z024	RIGHT COLLECTOR
23	P1028Z2028	RUBBER GASKET
24	P1028Z2026	UPPER BAG SUPPORT (G1030Z2)
25	G5556	UPPER BAG 2.5 MICRON (G1030Z2)
25	H5783	CANISTER FILTER (G0562Z)
26	P1028Z2025	SPACER
27	P1030Z2027	INLET 7" X 4" X 4" X 4"
27-1	P1028Z2029-1	INLET CAP 4"
28	PK28M	KEY 7 X 7 X 29
29V2	P1030Z2029V2	POWER CORD 14G X 3C 6' 6-20 V2.09.11
30	PWR1012	WRENCH 10 X 12
31	PAW05M	HEX WRENCH 5MM
32	P1030Z2P032	BELT CLAMP
33	PS06	PHLP HD SCR 10-24 X 3/8
34V2	P1030Z2104V2	MACHINE ID LABEL CSA 09.11 (G1030Z2)
34V2	P0562Z034V2	MACHINE ID LABEL CSA 09.11 (G0562Z)
35	P1030Z2035	FOAM STRIP 4 X 20MM
36	PLABEL-11	SAFETY GLASSES LABEL
37	PLABEL-39	RESPIRATOR LABEL
38	PLABEL-59	HANDS/OUTLET LABEL
39	PLABEL-14	ELECTRICITY LABEL
40	PLABEL-12A	READ MANUAL LABEL
42	G8588	GRIZZLY NAMEPLATE- SMALL
43	PPAINT-1	GRIZZLY GREEN PAINT (G1030Z2)

## H5783 Canister Filter Assembly

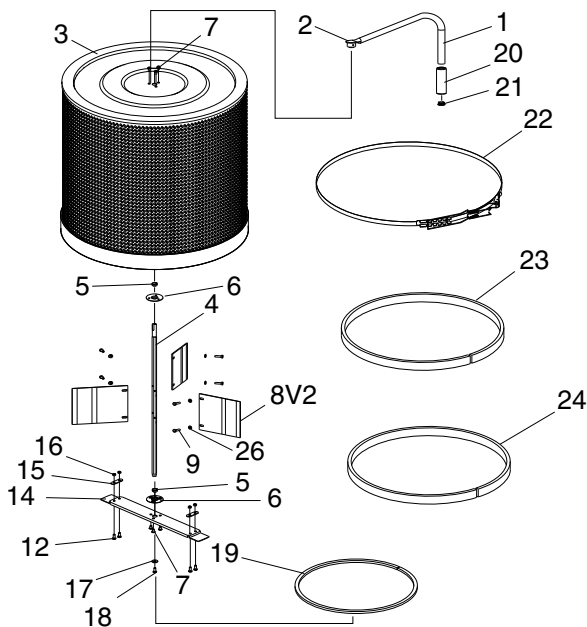

REF	PART #	DESCRIPTION
1	PH5783001	CLEANING HANDLE
2	PB83M	HEX BOLT M6-1 X 16
3	PH5783003	CANISTER FILTER
4	PH5783004	HEX SPINDLE
5	PH5783005	THRUST BEARING 12 X 14 X 6
6	PH5783006	BEARING PLATE
7	PS09M	PHLP HD SCR M5-.8 X 10
8V2	PH5783008V2	PLASTIC FLAP BOARD V2.09.11
9	PS68M	PHLP HD SCR M6-1 X 10
12	PS20M	PHLP HD SCR M5-.8 X 15
14	PH5783014	BOTTOM PLATE
15	PH5783015	SUPPORT TAB
16	PN06M	HEX NUT M5-.8
17	PW06	FLAT WASHER 1/4
18	PS68M	PHLP HD SCR M6-1 X 10
19	PH5783019	SPONGE GASKET 10 X 15MM
20	PH5783020	HANDLE SLEEVE
21	PH5783021	HANDLE CAP
22	PH5783022	QUICK RELEASE CLAMP
23	PH5783023	FOAM STRIP 20MM X 156CM
24	PH5783024	FOAM STRIP 42MM X 156CM
26	PW03M	FLAT WASHER 6MM



# G0562ZP/G1030Z2P Main Breakdown

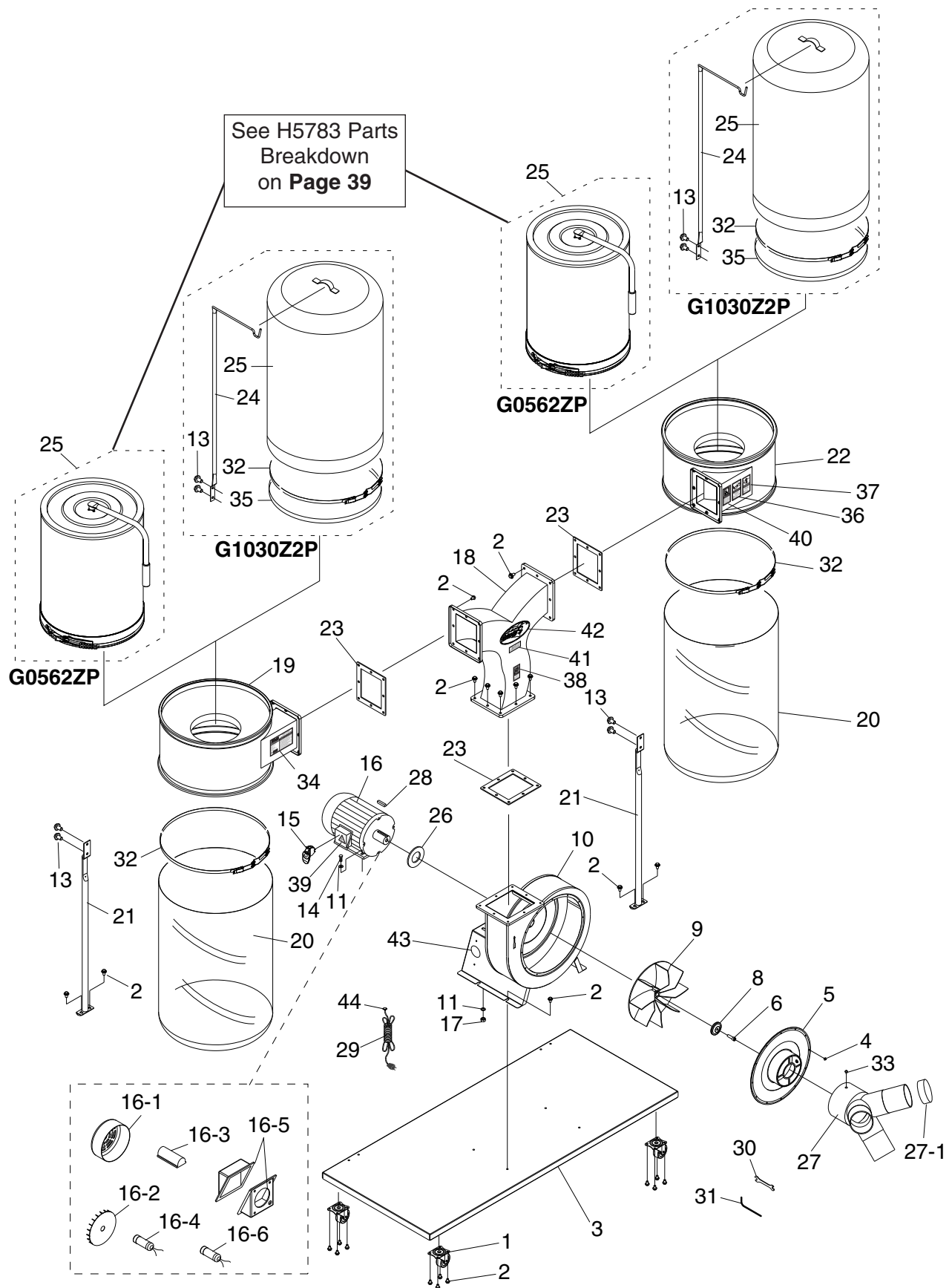

# G0562ZP/G1030Z2P Main Parts List

REF PART #	DESCRIPTION	
1	P1028Z2001	CASTER
2	PFB01	FLANGE BOLT 5/16-18 X 1/2
3	P1030Z2003	BASE PLATE
4	PS06	PHLP HD SCREW 10-24 X 3/8"
5	P1030Z2P005	INLET COVER 7"
6	PCAP121M	CAP SCREW M6-1 X 20 LH
8	P1028Z2009	IMPELLER WASHER
9	P1029Z2010V2	IMPELLER 12-3/4" ALUMINUM
10	P1030Z2P010	COLLECTOR BODY
11	PW07	FLAT WASHER 5/16
13	PFB01	FLANGE BOLT 5/16-18 X 1/2
14	PB03	HEX BOLT 5/16-18 X 1
15	P1030Z2015V2	PADDLE SWITCH
16	P1030Z2016V2	MOTOR 3HP 220V 1PH
16-1	P1030Z2016V2-1	MOTOR FAN COVER
16-2	P1030Z2016V2-2	MOTOR FAN
16-3	P1030Z2016V2-3	CAPACITOR COVER
16-4	P1030Z2016V2-4	S CAPACITOR 500M 125V
16-5	P1030Z2016V2-5	JUNCTION BOX
16-6	P1030Z2016V2-6	R CAPACITOR 40M 300V
17	PN02	HEX NUT 5/16-18
18	P1030Z2P018	METAL Y OUTLET
19	P1030Z2P019	LEFT COLLECTOR
20	T20543	LOWER COLLECTOR BAG
21	P1028Z2023	COLLECTOR SUPPORT
22	P1030Z2P022	RIGHT COLLECTOR

REF PART #	DESCRIPTION	
23	P1028Z2028	RUBBER GASKET
24	P1028Z2026	UPPER BAG SUPPORT (G1030Z2P)
25	H5783	CANISTER FILTER (G0562ZP)
25	G5556	UPPER BAG 2.5 MICRON (G1030Z2P)
26	P1028Z2025	SPACER
27	P1030Z2P027	INLET 7" X 4" X 4" X 4"
27-1	P1028Z2029-1	INLET CAP 4"
28	PK28M	KEY 7 X 7 X 29
29	P1030Z2029V2	POWER CORD 14AWG X 3C 6' 6-20
30	PWR1012	WRENCH 10 X 12
31	PAW05M	HEX WRENCH 5MM
32	P1030Z2P032	BELT CLAMP
33	PFS03	FLANGE SCREW 10-24 x 3/8
34	P0562ZP034	MACHINE ID LABEL CSA (G0562ZP)
34	P1030Z2P034	MACHINE ID LABEL CSA (G1030Z2P)
35	P1030Z2035	FOAM STRIP 4 X 20MM
36	PLABEL-11	SAFETY GLASSES LABEL
37	PLABEL-39	RESPIRATOR LABEL
38	PLABEL-59	HANDS/OUTLET LABEL
39	PLABEL-14	ELECTRICITY LABEL
40	PLABEL-12A	READ MANUAL LABEL
41	PLABEL-81	POLAR BEAR LOGO 1 X 3-3/4
42	G8588	GRIZZLY NAMEPLATE- SMALL
43	PPAINT-24	POLAR BEAR PAINT
44	P1030Z2P044	STRAIN RELIEF TYPE-1 3/4

## WARNING

Safety labels warn about machine hazards and ways to prevent injury. The owner of this machine **MUST** maintain the original location and readability of the labels on the machine. If any label is removed or becomes unreadable, **REPLACE** that label before using the machine again. Contact Grizzly at (800) 523-4777 or [www.grizzly.com](http://www.grizzly.com) to order new labels.







# WARRANTY CARD

Name \_\_\_\_\_  
 Street \_\_\_\_\_  
 City \_\_\_\_\_ State \_\_\_\_\_ Zip \_\_\_\_\_  
 Phone # \_\_\_\_\_ Email \_\_\_\_\_  
 Model # \_\_\_\_\_ Order # \_\_\_\_\_ Serial # \_\_\_\_\_

The following information is given on a voluntary basis. It will be used for marketing purposes to help us develop better products and services. **Of course, all information is strictly confidential.**

1. How did you learn about us?

Advertisement       Friend       Catalog  
 Card Deck       Website       Other:

2. Which of the following magazines do you subscribe to?

<input type="checkbox"/> Cabinetmaker & FDM	<input type="checkbox"/> Popular Science	<input type="checkbox"/> Wooden Boat
<input type="checkbox"/> Family Handyman	<input type="checkbox"/> Popular Woodworking	<input type="checkbox"/> Woodshop News
<input type="checkbox"/> Hand Loader	<input type="checkbox"/> Precision Shooter	<input type="checkbox"/> Woodsmith
<input type="checkbox"/> Handy	<input type="checkbox"/> Projects in Metal	<input type="checkbox"/> Woodwork
<input type="checkbox"/> Home Shop Machinist	<input type="checkbox"/> RC Modeler	<input type="checkbox"/> Woodworker West
<input type="checkbox"/> Journal of Light Cont.	<input type="checkbox"/> Rifle	<input type="checkbox"/> Woodworker's Journal
<input type="checkbox"/> Live Steam	<input type="checkbox"/> Shop Notes	<input type="checkbox"/> Other:
<input type="checkbox"/> Model Airplane News	<input type="checkbox"/> Shotgun News	
<input type="checkbox"/> Old House Journal	<input type="checkbox"/> Today's Homeowner	
<input type="checkbox"/> Popular Mechanics	<input type="checkbox"/> Wood	

3. What is your annual household income?

\$20,000-\$29,000       \$30,000-\$39,000       \$40,000-\$49,000  
 \$50,000-\$59,000       \$60,000-\$69,000       \$70,000+

4. What is your age group?

20-29       30-39       40-49  
 50-59       60-69       70+

5. How long have you been a woodworker/metalworker?

0-2 Years       2-8 Years       8-20 Years       20+ Years

6. How many of your machines or tools are Grizzly?

0-2       3-5       6-9       10+

7. Do you think your machine represents a good value?       Yes       No

8. Would you recommend Grizzly Industrial to a friend?       Yes       No

9. Would you allow us to use your name as a reference for Grizzly customers in your area?

**Note:** We never use names more than 3 times.       Yes       No

10. Comments: \_\_\_\_\_  
 \_\_\_\_\_  
 \_\_\_\_\_  
 \_\_\_\_\_

CUT ALONG DOTTED LINE

FOLD ALONG DOTTED LINE

\_\_\_\_\_
\_\_\_\_\_
\_\_\_\_\_



Place Stamp Here



GRIZZLY INDUSTRIAL, INC.
P.O. BOX 2069
BELLINGHAM, WA 98227-2069



FOLD ALONG DOTTED LINE

Send a Grizzly Catalog to a friend:

Name \_\_\_\_\_
Street \_\_\_\_\_
City \_\_\_\_\_ State \_\_\_\_\_ Zip \_\_\_\_\_

TAPE ALONG EDGES--PLEASE DO NOT STAPLE

# WARRANTY AND RETURNS

---

Grizzly Industrial, Inc. warrants every product it sells for a period of **1 year** to the original purchaser from the date of purchase. This warranty does not apply to defects due directly or indirectly to misuse, abuse, negligence, accidents, repairs or alterations or lack of maintenance. This is Grizzly's sole written warranty and any and all warranties that may be implied by law, including any merchantability or fitness, for any particular purpose, are hereby limited to the duration of this written warranty. We do not warrant or represent that the merchandise complies with the provisions of any law or acts unless the manufacturer so warrants. In no event shall Grizzly's liability under this warranty exceed the purchase price paid for the product and any legal actions brought against Grizzly shall be tried in the State of Washington, County of Whatcom.

We shall in no event be liable for death, injuries to persons or property or for incidental, contingent, special, or consequential damages arising from the use of our products.

To take advantage of this warranty, contact us by mail or phone and give us all the details. We will then issue you a "Return Number," which must be clearly posted on the outside as well as the inside of the carton. We will not accept any item back without this number. Proof of purchase must accompany the merchandise.

The manufacturers reserve the right to change specifications at any time because they constantly strive to achieve better quality equipment. We make every effort to ensure that our products meet high quality and durability standards and we hope you never need to use this warranty.

Please feel free to write or call us if you have any questions about the machine or the manual.

Thank you again for your business and continued support. We hope to serve you again soon.

**grizzly.com**<sup>®</sup>  
**TOOL WEBSITE**

Buy Direct and Save with Grizzly<sup>®</sup> – Trusted, Proven and a Great Value!  
~Since 1983~

*Visit Our Website Today For  
Current Specials!*

**ORDER  
24 HOURS A DAY!  
1-800-523-4777**

