



ELSEVIER

Available online at [www.sciencedirect.com](http://www.sciencedirect.com)

SCIENCE @ DIRECT®

Journal of Computational and Applied Mathematics 181 (2005) 245–251

JOURNAL OF  
COMPUTATIONAL AND  
APPLIED MATHEMATICS[www.elsevier.com/locate/cam](http://www.elsevier.com/locate/cam)

# Variational iteration method for solving Burger's and coupled Burger's equations

M.A. Abdou<sup>a</sup>, A.A. Soliman<sup>b,\*</sup><sup>a</sup>*Theoretical Research Group, Department of Physics, Faculty of Science, Mansoura University, Mansoura, Egypt*<sup>b</sup>*Department of Mathematics, Faculty of Education (AL-Arish), Suez Canal University, AL-Arish 45111, Egypt*

Received 14 June 2004; received in revised form 19 November 2004

## Abstract

By means of variational iteration method the solutions of Burger's equation and coupled Burger's equations are exactly obtained, comparison with the Adomian decomposition method is made, showing that the former is more effective than the later. In this paper, He's variational iteration method is introduced to overcome the difficulty arising in calculating Adomian polynomials.

© 2004 Elsevier B.V. All rights reserved.

*Keywords:* Burger's equations; Variational iteration method; Nonlinear partial differential equations; Lagrange multiplier

## 1. Introduction

Up to now more and more nonlinear equations were presented, which described the motion of the isolated waves, localized in a small part of space, in many fields such as hydrodynamic, plasma physics, nonlinear optic, etc. The investigation of exact solutions of these nonlinear equations is interesting and important. In the past several decades, many authors mainly had paid attention to study solutions of nonlinear equations by using various methods, such as Backlund transformation [1,7], Darboux transformation [34], inverse scattering method [13], Hirota's bilinear method [22], the tanh method [27], the sine–cosine method [40,41], the homogeneous balance method [35,42], the Riccati expansion method with constant coefficients [43,44]. Recently, an extended tanh-function method and symbolic

\* Corresponding author. Tel.: +20 101 293 727; fax: +20 683 500 65.

*E-mail addresses:* [M\\_Abdou\\_eg@yahoo.com](mailto:M_Abdou_eg@yahoo.com) (M.A. Abdou), [asoliman\\_99@yahoo.com](mailto:asoliman_99@yahoo.com) (A.A. Soliman).

computation are suggested in [11] for solving the new coupled modified KDV equations to obtain four kinds of soliton solutions. This method has some merits in contrast with the tanh-function method. It not only uses a simpler algorithm to produce an algebraic system, but also can pick up singular soliton solutions with no extra effort [12,23,28,32,39].

The numerical solution of Burger's equation is of great importance due to the equation's application in the approximate theory of flow through a shock wave travelling in a viscous fluid [8] and in the Burger's model of turbulence [4]. It is solved analytically for arbitrary initial conditions [24]. Finite element methods have been applied to fluid problems, Galerkin and Petrov–Galerkin finite element methods involving a time-dependent grid [6,21]. Numerical solution using cubic spline global trial functions were developed in [31] to obtain two systems or diagonally dominant equations which are solved to determine the evolution of the system. A collocation solution with cubic spline interpolation functions used to produce three coupled sets of equations for the dependent variable and its two first derivatives [5]. Ali et al. [3] applied B-spline finite element methods to the solution of Burger's equation. The B-spline finite element approach applied with collocation method over a constant grid of cubic B-spline elements. Cubic B-spline had a resulting matrix system which is tri-diagonal and so solved by the Thomas algorithm. Soliman [33] used the similarity reductions for the partial differential equations to develop a scheme for solving the Burger's equation. This scheme is based on similarity reductions of Burger's equation on small sub-domains. The resulting similarity equation is integrated analytically. The analytical solution is then used to approximate the flux vector in Burger's equation.

The coupled system is derived by Esipov [10]. It is simple model of sedimentation or evolution of scaled volume concentrations of two kinds of particles in fluid suspensions or colloids, under the effect of gravity [30].

The variational iteration method was first proposed by He [14–17] and was successfully applied to autonomous ordinary differential equations in [18], to nonlinear polycrystalline solids [29], and other fields. The combination of a perturbation method, variational iteration method, method of variation of constants and averaging method to establish an approximate solution of one degree of freedom weakly nonlinear system in [9]. The variational iteration method has many merits and has much advantages over the Adomian method [37].

The aim of this paper is to extend the variational iterations method proposed by He [14–17,19,20] to solve two different types such as the one-dimensional Burger's equation and coupled Burger's equations and comparison with that obtained previously by the Adomian decomposition method [2,25,26,36,38].

## 2. Variational iteration method

To illustrate its basic concepts of the variational iteration method, we consider the following differential equation:

$$Lu + Nu = g(x), \quad (1)$$

where  $L$  is a linear operator,  $N$  a nonlinear operator, and  $g(x)$  an inhomogeneous term.

According to the variational iteration method, we can construct a correct functional as follows:

$$u_{n+1}(x) = u_n(x) + \int_0^x \lambda \{Lu_n(\tau) + N\tilde{u}_n(\tau) - g(\tau)\} d\tau, \quad (2)$$

where  $\lambda$  is a general Lagrangian multiplier [14–17], which can be identified optimally via the variational theory, the subscript  $n$  denotes the  $n$ th-order approximation,  $\tilde{u}_n$  is considered as a restricted variation [14–17], or see He’s monographs [19,20] i.e.  $\delta \tilde{u}_n = 0$ .

To illustrate the above theory, two examples of special interest such as one-dimensional Burger’s and coupled Burger’s equations are discussed in details and the obtained results are exactly the same with that found by the Adomian decomposition method [25,26].

### 3. Applications

#### 3.1. One-dimensional Burger’s equation

Consider that the one-dimensional Burger’s equation has the form [4]

$$u_t + uu_x - vu_{xx} = 0 \tag{3}$$

with an initial condition

$$u(x, 0) = \frac{\alpha + \beta + (\beta - \alpha) \exp(\gamma)}{1 + \exp(\gamma)}, \quad t \geq 0, \tag{4}$$

where  $\gamma = (\alpha/v)(x - \lambda)$  and the parameters  $\alpha, \beta, \lambda,$  and  $v$  are arbitrary constants.

To solve Eq. (3) by means of the variational iteration method, we construct a correction functional which reads

$$u_{n+1}(x, t) = u_n(x, 0) + \int_0^t \lambda \{u_t + u\tilde{u}_x - v\tilde{u}_{xx}\} d\tau, \tag{5}$$

where  $\delta \tilde{u}_n$  is considered as a restricted variation. Its stationary conditions can be obtained as follows:

$$\lambda'(\tau) = 0, \tag{6a}$$

$$1 + \lambda(\tau) \Big|_{\tau=t} = 0. \tag{6b}$$

Eq. (6a) is called Lagrange–Euler equation, and Eq. (6b) natural boundary condition.

The Lagrange multiplier, therefore, can be identified as  $\lambda = -1$ , and the following variational iteration formula can be obtained:

$$u_{n+1}(x, t) = u_n(x, 0) - \int_0^t \{(u_t)_n + u_n u_{nx} - v u_{nxx}\} d\tau. \tag{7}$$

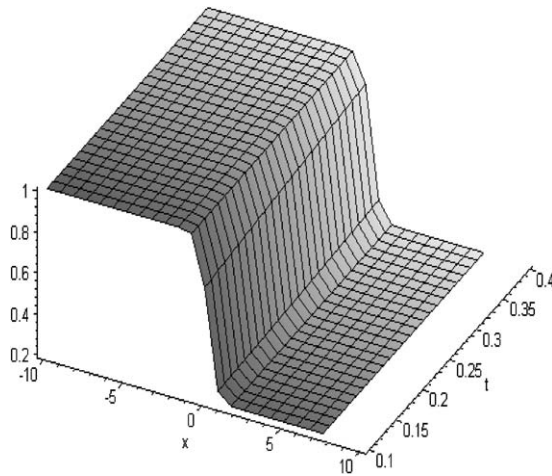

Fig. 1. The behavior of  $u(x, t)$  evaluates by variational iteration method versus  $x$  for different values of time with fixed values  $v = 1, \epsilon = 1, \lambda = 0.125, \beta = 0.6, \alpha = 0.4$ .

We start with an initial approximation  $u_0 = u(x, 0)$  given by Eq. (4), by the above iteration formula (7), we can obtain directly the other components as

$$u_1(x, t) = \frac{\alpha + \beta + (\beta - \alpha) \exp(\gamma)}{1 + \exp(\gamma)} + \frac{2\alpha\beta^2 \exp(\gamma)}{v[1 + \exp(\gamma)]^2} t, \tag{8}$$

$$u_2(x, t) = \frac{\alpha + \beta + (\beta - \alpha) \exp(\gamma)}{1 + \exp(\gamma)} + \frac{2\alpha\beta^2 \exp(\gamma)}{v[1 + \exp(\gamma)]^2} + \frac{\alpha^3\beta^2 \exp(\gamma)[-1 + \exp(\gamma)]}{v^2[1 + \exp(\gamma)]^3} t^2, \tag{9}$$

$$u_3(x, t) = u_2 + \frac{\alpha^4\beta^3 \exp(\gamma)[1 - 4\exp(\gamma) + \exp(\gamma)^2]}{3v^3[1 + \exp(\gamma)]^4} t^3 \tag{10}$$

and so on, in the same manner the rest of components of the iteration formula (7) were obtained using the Maple Package. The solution of  $u(x, t)$  in a closed form is

$$u(x, t) = \frac{\alpha + \beta + (\beta - \alpha) \exp(\zeta)}{1 + \exp(\zeta)}, \tag{11}$$

where  $\zeta = (\alpha/v)(x - \beta t - \lambda)$ , which are exactly the same as obtained by Adomian decomposition method [26].

The behavior of the solutions obtained by the variational iteration method is shown for different values of times in Fig. 1.

### 3.2. Coupled Burger's equations

For the purpose of illustration of the variational iteration method for solving the homogeneous form of coupled Burger's equations, we will consider the system of equations

$$u_t - u_{xx} - 2uu_x + (uv)_x = 0, \tag{12}$$

$$v_t - v_{xx} - 2vv_x + (uv)_x = 0, \quad (13)$$

the solutions of which are to be obtained subject to the initial conditions

$$u(x, 0) = \sin x, \quad v(x, 0) = \sin x. \quad (14)$$

To solve the system of equations (12), (13) by means of the variational iteration method, we construct the following correction functionals:

$$u_{n+1}(x, t) = u_n(x, 0) + \int_0^t \lambda_1 \{ (u_t)_n - u_{nxx} - 2u_n \tilde{u}_{nx} + (u_n \tilde{v}_n)_x \} d\tau, \quad (15)$$

$$v_{n+1}(x, t) = v_n(x, 0) + \int_0^t \lambda_2 \{ (v_t)_n - v_{nxx} - 2v_n \tilde{v}_{nx} + (u_n \tilde{v}_n)_x \} d\tau, \quad (16)$$

where  $\lambda_1$  and  $\lambda_2$  are general Lagrange multipliers, and  $u_n \tilde{u}_{nx}$ ,  $(u_n \tilde{v}_n)_x$ , and  $v_n \tilde{v}_{nx}$  denote restricted variations i.e.  $\delta u_n \tilde{u}_{nx} = \delta (u_n \tilde{v}_n)_x = \delta v_n \tilde{v}_{nx} = 0$ .

Making the above correction functional stationary, we obtain the following stationary conditions:

$$\begin{aligned} \lambda_1'(\tau) &= 0, \\ 1 + \lambda_1(\tau) \Big|_{\tau=t} &= 0, \\ \lambda_2'(\tau) &= 0, \\ 1 + \lambda_2(\tau) \Big|_{\tau=t} &= 0. \end{aligned} \quad (17)$$

The Lagrangian multipliers, therefore, can be identified as

$$\lambda_1 = \lambda_2 = -1. \quad (18)$$

Substituting Eq. (18) into the correction functional equations (15) and (16) results in the following iteration formula:

$$u_{n+1}(x, t) = u_n(x, 0) - \int_0^t \{ (u_t)_n - u_{nxx} - 2u_n u_{nx} + (u_n v_n)_x \} d\tau, \quad (19)$$

$$v_{n+1}(x, t) = v_n(x, 0) - \int_0^t \{ (v_t)_n - v_{nxx} - 2v_n v_{nx} + (u_n v_n)_x \} d\tau. \quad (20)$$

We start with initial approximations given by Eqs. (14) and by the above iteration formula we can obtain the following results:

$$u_1(x, t) = \sin x - t \sin x, \quad (21)$$

$$v_1(x, t) = \sin x - t \sin x, \quad (22)$$

$$u_2(x, t) = \sin x - t \sin x + \frac{t^2}{2!} \sin x, \quad (23)$$

$$v_2(x, t) = \sin x - t \sin x + \frac{t^2}{2!} \sin x, \quad (24)$$

$$u_3(x, t) = \sin x - t \sin x + \frac{t^2}{2!} \sin x - \frac{t^3}{3!} \sin x, \quad (25)$$

$$v_3(x, t) = \sin x - t \sin x + \frac{t^2}{2!} \sin x - \frac{t^3}{3!} \sin x \quad (26)$$

and so on. Proceeding as before the rest of components were obtained, and then the two functions  $u(x, t)$  and  $v(x, t)$  in the closed form are readily found to be

$$u(x, t) = \exp(-t) \sin x, \quad (27)$$

$$v(x, t) = \exp(-t) \sin x, \quad (28)$$

which are exactly the same as those obtained by the Adomian decomposition method [25].

#### 4. Conclusions

In this paper, the variational iteration method has been successfully applied to finding the solution of a Burger's and coupled Burger's equations. The solution obtained by the variational iteration method is an infinite power series for appropriate initial condition, which can, in turn, be expressed in a closed form, the exact solution. The results show that the variational iteration method is a powerful mathematical tool to solving Burger's and coupled Burger's equations, it is also a promising method to solve other nonlinear equations. The solutions obtained are shown graphically. In our work, we use the Maple Package to calculate the series obtained from the variational iteration method.

#### Acknowledgements

The authors would like to thank the referees for their comments and discussions.

#### References

- [1] M.J. Ablowitz, P.A. Clarkson, *Solitons, Nonlinear Evolution Equations and Inverse Scattering*, Cambridge University Press, Cambridge, 1991.
- [2] G. Adomian, *Math. Comput. Modelling* 22 (1995) 103.
- [3] A.H.A. Ali, G.A. Gardner, L.R.T. Gardner, *Comput. Methods Appl. Mech. Eng.* 100 (1992) 325–337.
- [4] J. Burgers, in: *Advances in Applied Mechanics*, Academic Press, New York, 1948, pp. 171–199.
- [5] J. Caldwell, E. Hinton, et al. (Eds.), *Numerical Methods for Nonlinear Problems*, Pineridge, Swansea, vol. 3, 1987, pp. 253–261.
- [6] J. Caldwell, P. Wanless, A.E. Cook, *Appl. Math. Modelling* 5 (1981) 189–193.
- [7] A. Coely, et al. (Eds.), *Backlund and Darboux Transformations*, American Mathematical Society, Providence, RI, 2001.
- [8] J.D. Cole, *Quart. Appl. Math.* 9 (1951) 225–236.
- [9] Gh.E. Draganescu, V. Capalnasan, *Internat. J. Nonlinear Sci. Numer. Simulation* 4 (2004) 219–226.
- [10] S.E. Esipov, *Phys. Rev. E* 52 (1995) 3711–3718.
- [11] E. Fan, *Phys. Lett. A* 282 (2001) 18.
- [12] E.G. Fan, H.Q. Zhang, *Phys. Lett. A* 246 (1998) 403.
- [13] C.S. Gardner, J.M. Green, M.D. Kruskal, R.M. Miura, *Phys. Rev. Lett.* 19 (1967) 1095.
- [14] J.H. He, *Comm. Nonlinear Sci. Numer. Simulation* 2 (4) (1997) 230–235.

- [15] J.H. He, *Comput. Methods Appl. Mech. Eng.* 167 (1998) 57–68.
- [16] J.H. He, *Comput. Methods Appl. Mech. Eng.* 167 (1998) 69–73.
- [17] J.H. He, *Internat. J. Non-linear Mech.* 34 (1999) 699–708.
- [18] J.H. He, *Appl. Math. Comput.* 114 (2,3) (2000) 115–123.
- [19] J.H. He, *Approximate Analytical Methods in Science and Engineering*, Henan Sci. & Tech. Press, Zhengzhou, 2002 (in Chinese).
- [20] J.H. He, *Generalized Variational Principles in Fluids*, Science & Culture Publishing House of China, Hong Kong, 2003 (in Chinese).
- [21] B.M. Herbst, S.W. Schoombie, A.R. Mitchell, *Internat. J. Numer. Methods Eng.* 18 (1982) 1321–1336.
- [22] R. Hirota, *Phys. Rev. Lett.* 27 (1971) 1192.
- [23] R. Hirota, J. Satsuma, *Phys. Lett. A* 85 (1981) 407.
- [24] E. Hopf, *The partial differential equation*, *Comm. Pure Appl. Math.* 3 (1950) 201–230.
- [25] D. Kaya, *Internat. J. Math. Math. Sci.* 27 (2001) 675.
- [26] D. Kaya, *Appl. Math. Comput.* 144 (2003) 353–363.
- [27] W. Malfeit, *Amer. J. Phys.* 60 (1992) 650.
- [28] W. Malfliet, *Amer. J. Phys.* 60 (1992) 650.
- [29] V. Marinca, *Internat. J. Nonlinear Sci. Numer. Simulation* 3 (2002) 107–120.
- [30] J. Nee, J. Duan, *Appl. Math. Lett.* 11 (1) (1998) 57–61.
- [31] S.G. Rubin, R.A. Graves, *Computers and Fluids*, vol. 3, Pergamon Press, Oxford, 1975, p. 136.
- [32] J. Satsuma, R. Hirota, *J. Phys. Soc. Japan* 51 (1982) 332.
- [33] A.A. Soliman, *International Conference on Computational Fluid Dynamics*, Beijing, China, October 17–20, 2000, pp. 559–566.
- [34] M. Wadati, H. Sanuki, K. Konno, *Prog. Theor. Phys.* 53 (1975) 419.
- [35] M.L. Wang, *Phys. Lett. A* 215 (1996) 279.
- [36] A.M. Wazwaz, *Appl. Math. Comput.* 111 (2000) 53.
- [37] A.M. Wazwaz, *Comput. Math. Appl.* 4 (2001) 1237–1244.
- [38] A.M. Wazwaz, *Chaos Solitons Fractals* 12 (2001) 2283.
- [39] Y.T. Wu, X.G. Geng, X.B. Hu, S.M. Zhu, *Phys. Lett. A* 255 (1999) 259.
- [40] C.T. Yan, *Phys. Lett. A* 224 (1996) 77.
- [41] Z.Y. Yan, H.Q. Zhang, *Appl. Math. Mech.* 21 (2000) 382.
- [42] Z.Y. Yan, H.Q. Zhang, *J. Phys. A* 34 (2001) 1785.
- [43] Z.Y. Yan, H.Q. Zhang, *Phys. Lett. A* 285 (2001) 355.
- [44] Z.Y. Yan, *Phys. Lett. A* 292 (2001) 100.