

The logo for etap, featuring the word "etap" in a bold, red, italicized sans-serif font with a registered trademark symbol (®) to the upper right.

Energy Management Solutions

to Design, Operate, and Automate Power Systems



The unified **electrical** digital twin platform

Sectors & Solutions

ETAP is the Global Market and Technology Leader of power systems solutions for a broad spectrum of sectors including Generation, Transmission, Distribution, Transportation, Industrial, and Commercial.

Powering the World

The most comprehensive and integrated model-driven solutions for design, simulation, analysis, optimization, monitoring, operation, and automation of electrical power systems.



Generation

Transmission

Distribution

Transportation

Industrial

Commercial & Critical Facilities

From renewable to nuclear, the world's power generation plants rely on ETAP

- ✓ Grid Interconnection Studies
- ✓ Renewable Penetration Studies
- ✓ Design & Analyze Solar & Wind Farms
- ✓ Validation & Compliance Reports
- ✓ Dynamic Parameter Tuning
- ✓ Generation Protection
- ✓ Power Train, Aux & Safety Systems
- ✓ Unit Commitment & Dispatch
- ✓ Microgrid Modeling, Design & Control
- ✓ Generation Management System
- ✓ Operator Training Simulator
- ✓ Generation Management System
- ✓ Centralized Relay Asset Management
- ✓ Plant Accounting & Settlement System

Integrated grid modeling, planning, protection, and energy management solutions

- ✓ Multi-Area Network Planning & Simulation
- ✓ Grid Code Compliance & Evaluation
- ✓ Grid Interconnection Studies
- ✓ HVDC Link & FACTS Models
- ✓ Overhead Line Distance Protection
- ✓ Line Constants & Coupling
- ✓ Outage Assessment
- ✓ Sensitivity Analysis
- ✓ Electromagnetic Transients
- ✓ Substation Grounding Design & Analysis
- ✓ Security Constrained Optimization
- ✓ Energy Management System
- ✓ Centralized Relay Asset Management
- ✓ Automated Fault Analysis System

Modeling, planning and operation of state-city-wide power distribution networks

- ✓ Planning & Optimization Studies
- ✓ Intelligent GIS & Logical Diagrams
- ✓ Substation & Feeder Diagrams
- ✓ Equipment Warehouse & Sizing
- ✓ Reliability Assessment & Indices
- ✓ Substation & Feeder Automation
- ✓ Smart Grid Management & Optimization
- ✓ Advanced Fault Detection & Location
- ✓ Automated Fault Analysis System
- ✓ Automated Outage Restoration
- ✓ Demand Response & Load Shedding
- ✓ Integrated DMS & OMS Solution
- ✓ Centralized Relay Asset Management
- ✓ Dispatcher Training Simulator

AC & DC electrical system analysis for railways, marine, and aerospace

- ✓ Rail Traction System
Solution for analysis and operation of HV & LV railway power and signaling systems
- ✓ Marine, Offshore & Shipbuilding
Design, operate and maintain ship, platform, and port power systems safely, while improving critical uptime
- ✓ Airports & Aerospace
Model, simulate, analyze, and operate airport & aerospace unified AC & DC power systems

Intelligent solutions for oil & gas, mining & metals, and manufacturing plants

- ✓ 'What If' Studies with Multiple Results of Load Flow, Faults & Arc Flash Studies and more
- ✓ Validate before Operate
- ✓ System Loss Reduction & Reactive Compensation Studies
- ✓ Equipment Capacity Sizing
- ✓ Acceleration Studies with Adjustable Drives
- ✓ Protective Device Auto-Evaluation
- ✓ Harmonic Evaluation & Limit Compliance
- ✓ Fast Load Shedding & Bus Transfer
- ✓ Predictive Analysis, Control & Automation
- ✓ Power Management System
- ✓ Electrical Control & Monitoring System
- ✓ Centralized Relay Asset Management
- ✓ Operator Training Simulator
- ✓ Situational Intelligence & Operator Awareness

Design, analysis, and protection of low voltage installations

- ✓ Dedicated Data Center Dashboards
- ✓ Dedicated Facility Dashboards
- ✓ Electrical Safety System Evaluation
- ✓ Redundancy Adequacy Assessment
- ✓ UPS Design, Monitoring & Control
- ✓ Failure Mode & Effects Analysis
- ✓ Rule-Based Design per Industry Guidelines
- ✓ Panel Board Schedules
- ✓ Cable Sizing & Thermal Analysis
- ✓ System / Zone Protection & Selectivity
- ✓ Power Quality Analysis & Mitigation
- ✓ Situational Intelligence & Operator Awareness
- ✓ Interface with Revit & BIM Software

Automate

- Intelligent Controllers
 - Microgrid
 - Nanogrid
 - Power Plant
 - Substation Automation
 - Remedial Action Schemes
 - Load Shedding & Restoration

Optimize

- Proactive Actions
 - N-n Situational Intelligence
 - Volt / Var Optimization
 - Economic Dispatch
 - Switching Optimization
 - Automatic Generation Control
 - Fault Isolation & Service Restoration

Operate & Manage

- Operational Awareness
 - Distribution Management
 - Switching Management
 - Outage Management
 - Load Management
 - Operator Training Simulator
 - Protection & Asset Management

Predict & Control

- Predictive Simulation
 - AC & DC Network Analysis
 - Grid Code Compliance
 - Failure Mode Analysis
 - Reliability Centered Maintenance
 - Short & Long-Term Load Forecasting

Model

- Intelligent Visualizations
 - Field Data Collection & Smart Data Entry
 - Wide Area Network Modeling Management
 - Multi-Dimensional Platform for Planning
 - Line & Cable Sizing, Capacity & Constants
 - Equipment Sizing & Capacity
 - Verified & Validated Manufacturer Libraries
 - Rulebooks & Warehouse

Simulate & Analyze

- AC & DC Network Analysis
 - Unified Multi-Systems
 - Arc Flash & Safety Systems
 - Protection & Coordination
 - Dynamics & Transients
 - Design & Optimization
 - Auto-Run Study Wizard

Monitor

- Model-Driven Monitoring
 - Power Management System
 - Intelligent Electrical SCADA
 - State Estimation & Load Allocation
 - Energy Tracking & Accounting
 - Sequence of Events Playback
 - Cloud & Mobile Interfaces

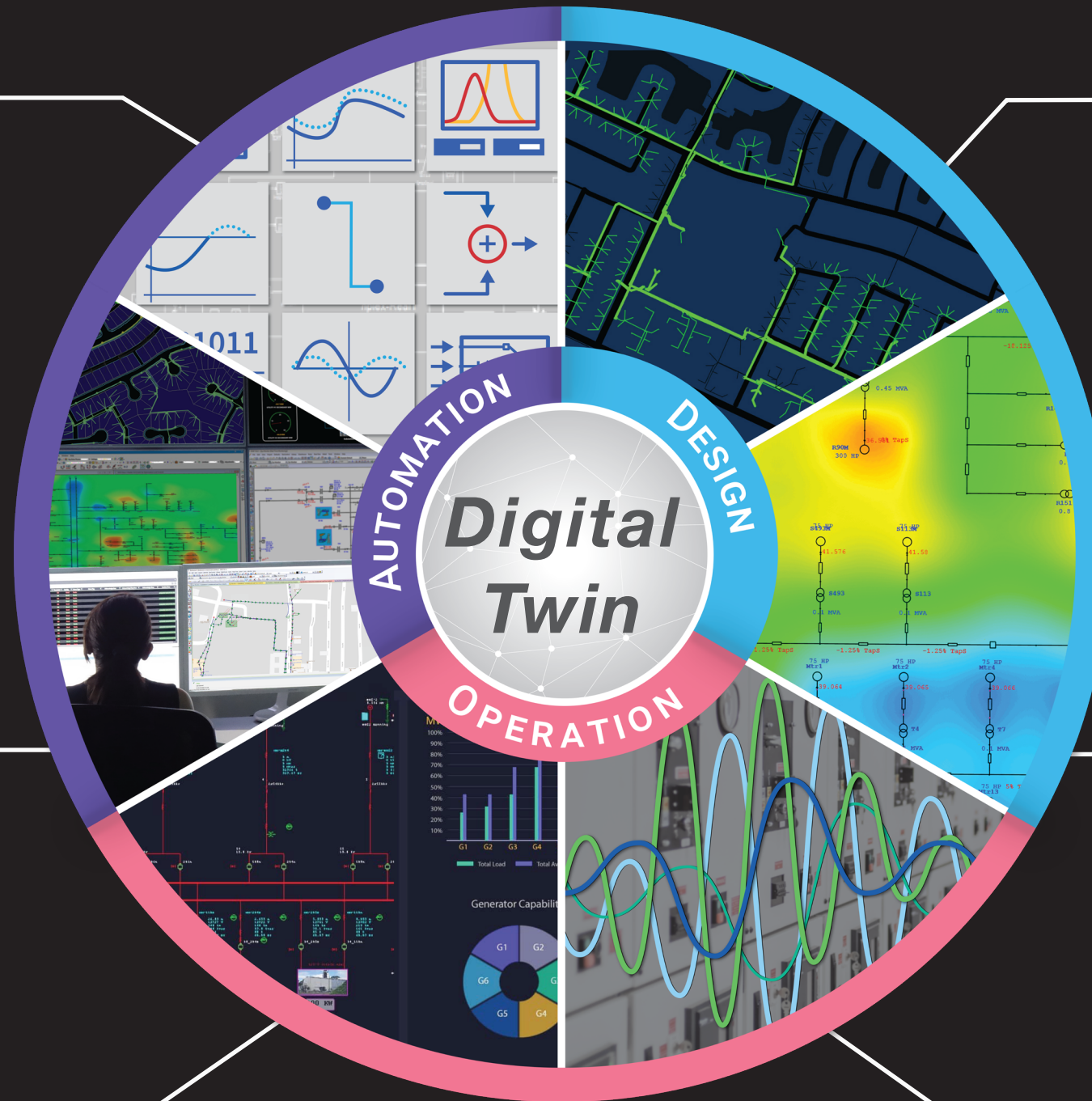

etapAPP™ Data Collection & Synchronization

A tablet application to streamline field data collection as well as model, verify, and visualize electrical systems using logical and geospatial asset location and connectivity.



Data Collection & Verification

- Collect data, verify existing data & transfer to ETAP
- Add nameplate & rating data
- Capture equipment pictures & link to model
- Tabular data view

System Modeling

- Build & modify one-line diagram
- Accept / Reject data changes
- Geo Tagging - equipment location
- Smart connections including Auto Insert
- Layered drawings for subsystems

Synchronization & Security

- Assign project access per substation or area
- Sync multiple users to one master project
- Wireless data exchange between users
- Synchronize with ETAP model using NetPM™
- Windows authentication for security



Designed for

Apple® iPad, Android & Microsoft® Surface tablets



NetPM™ Network Modeling & Project Management

A platform for collaborative engineering using smart management tools to shorten project delivery time for power system modeling and studies.

- ✓ Accelerate project change management
- ✓ Improve engineering design quality
- ✓ Built-in review & approval process
- ✓ Joint operation & control
- ✓ Simultaneous modeling & analysis
- ✓ Single source repository for all data changes
- ✓ Base & Revision data synchronization
- ✓ Collaborative GIS model management & synchronization

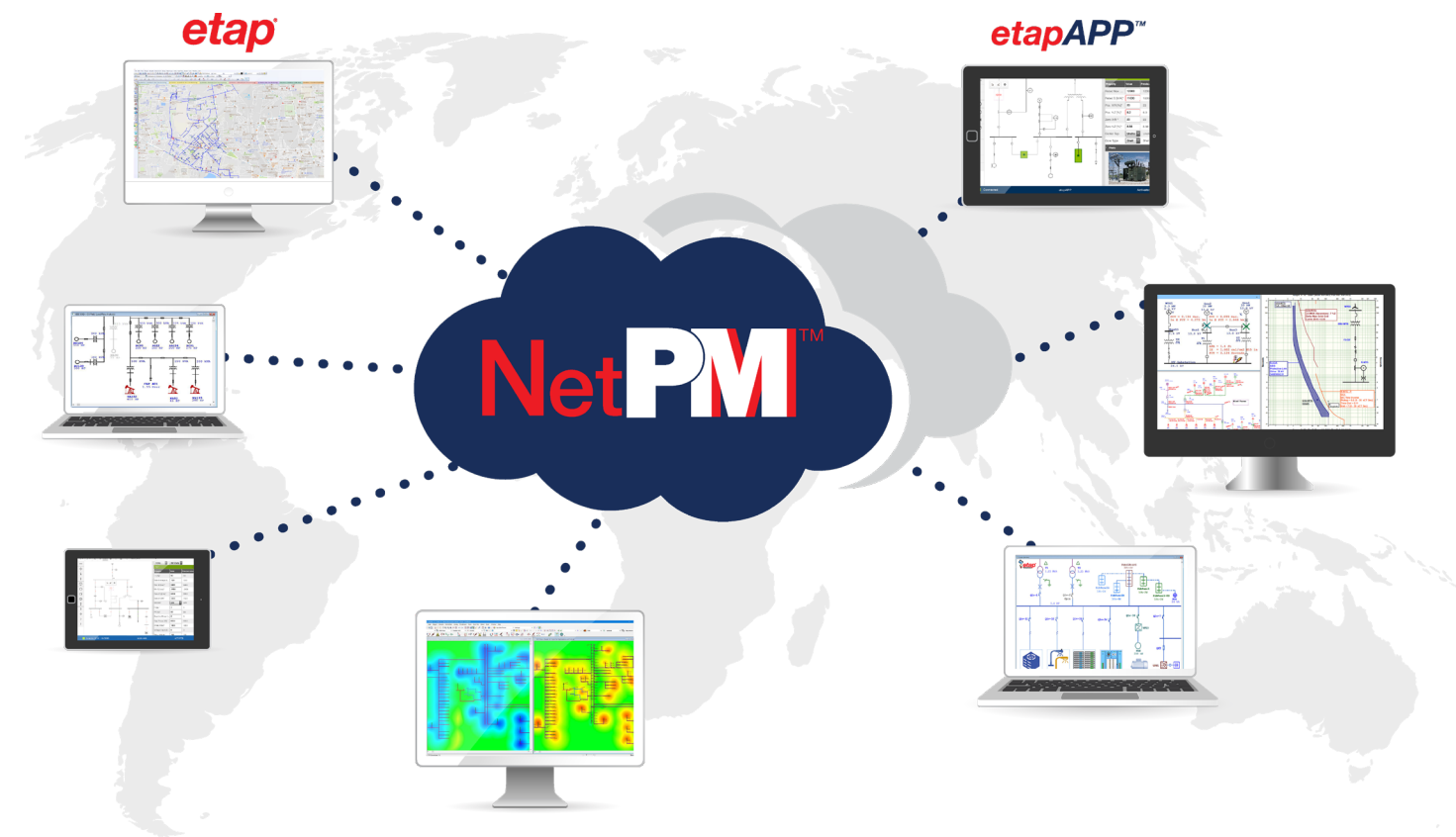

Increase Engineering Design Quality

Quickly identify and synchronize changes made to a project from multiple engineers - NetPM provides a platform for improved design validation through collaboration.

Improve Productivity

Increase productivity by having multiple engineers working in parallel on the same project - NetPM removes the time delay associated with the traditional sequential, re-circulation, and repetition of studies due to conflicting project solutions.

Accelerate Project Schedules

NetPM's multi-user management system drastically improves the efficiency of project completion time; whether data collection and project updates are done from etapAPP or from an engineering workstation, all changes are simultaneously reflected on the master model and approved updates are broadcasted to selected users.

System Modeling & Visualization

A comprehensive set of integrated AC & DC system design and analysis solutions built on a trusted, verified & validated platform with proven calculations.

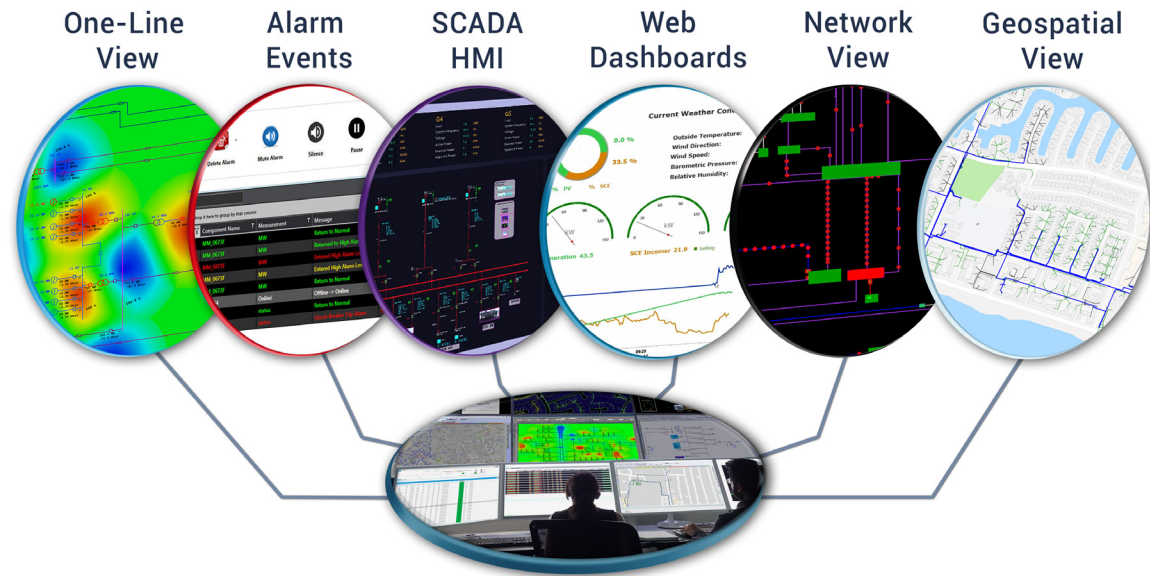

Multi-Dimensional Digital Twin

- Multi-dimensional planning using project wizards
- Rule-based data entry & modeling
- Scenario visualization & simulation
- Intelligent data exchange interfaces
- Server-client applications with user access control
- Base & Revision data layers with merge management
- etapPy™ – Scripting & Study Automation using Python™

Feeder, Substation & Network Diagram

- Synchronized electrical geospatial diagram, substation & equivalent circuit views
- Model 1,000s of components as an equivalent feeder
- Generate a logical feeder layout for individual or groups of feeders in single or multiple views
- Show simulation results on geospatial & feeder views

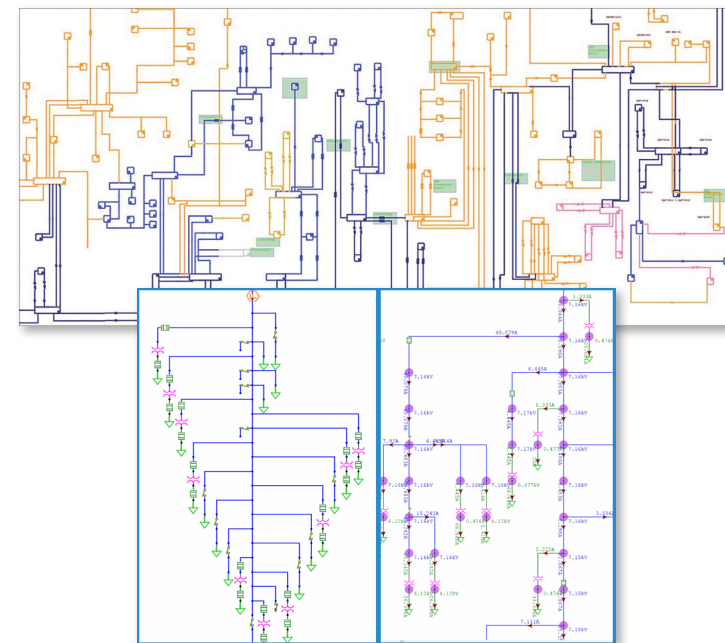

Intelligent One-line View

- One-line diagram & templates
- AutoBuild - Automatic equipment connection mode
- Built-in intelligent graphics
- Network nesting
- Synchronized GIS & one-line views

Geospatial View

- Intelligent electrical GIS view
- Distribution equipment modeling
- Intelligent circuit tracing & loop detection
- Incremental import from ESRI® & CIM

Power Flow Analysis

Industry benchmark for fast and accurate power flow calculations with automated simulation, intuitive interfaces, interactive graphical displays, and smart result analyzers.

Load Flow

Core load flow analysis module for demand evaluation, power flow analysis, losses, power factor correction, and voltage drop calculations.

- Automatic equipment evaluation
- Extensive violation alerts & reports
- Load Flow Result Analyzer

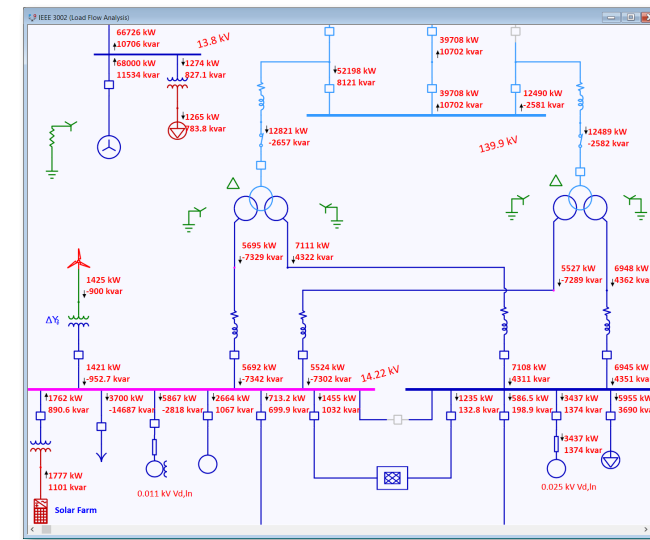

DC Load Flow

Robust DC power flow engine for design of the most critical applications.

- IEEE 946 Standard
- Battery storage auto-activation
- Rectifier / Charger / UPS modeling & actions

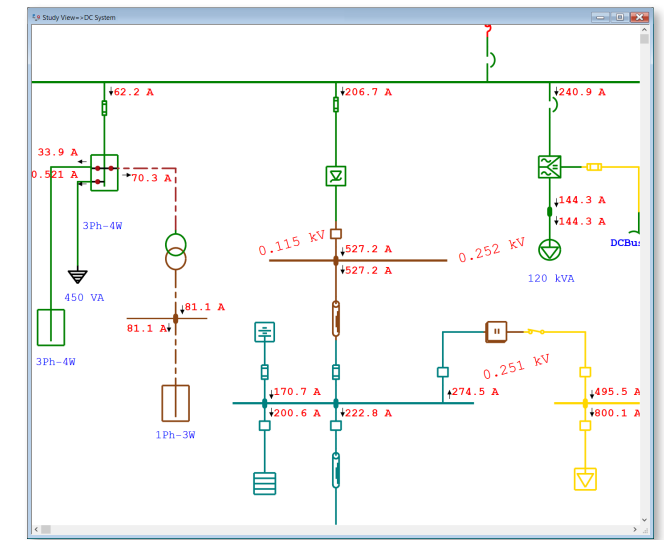

Unbalanced Load Flow

Accurately analyze 1-phase and unbalanced 3-phase, radial and looped electrical systems.

- Result visualization via ETAP GIS map
- Various grounding system types
- Series fault or open-phase condition modeling

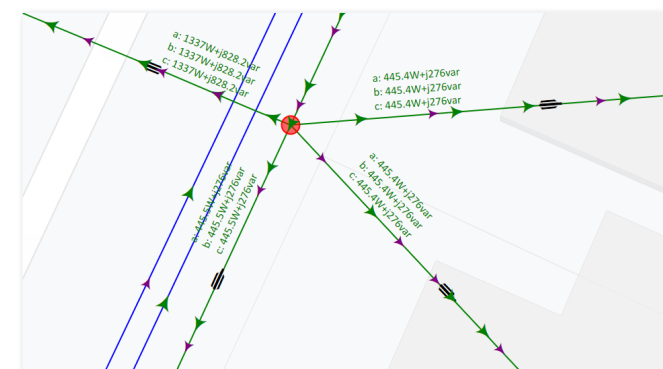

Quasi-Dynamic Unified Load Flow

Simultaneous power flow analysis of AC & DC with option for time-varying loading and generation.

- Solar & Wind Farms
- Railways
- Microgrids
- Aircraft & Airports
- Distribution
- Ports & Marine Vessels

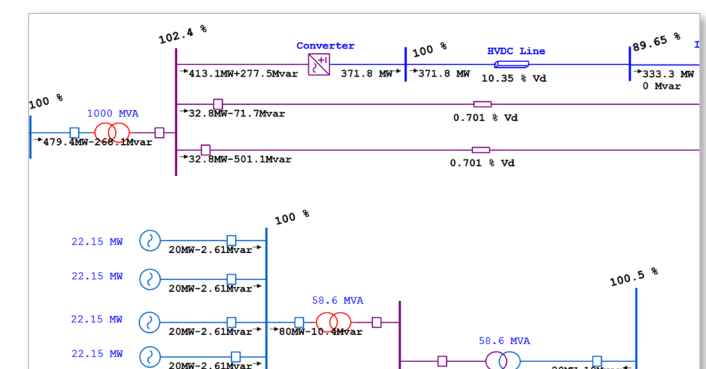

Short Circuit Analysis

Take the guesswork out of short circuit studies by automating the comparison of multiple calculation results in one click.

- ✓ Device duty evaluation
- ✓ 3-phase, 1-phase, & panel systems
- ✓ Load terminal fault current calculation & reporting
- ✓ Short Circuit Result Analyzer
- ✓ Display critical & marginal Alerts
- ✓ Looped & radial, AC & DC systems

ANSI / IEEE C37 & UL 489

Short circuit calculations with built-in intelligence to automatically apply all factors and ratios required for high & low voltage device duty evaluation.

- Calculate 1/2 cycle, 1.5-4, & 30 cycle balanced & unbalanced faults (3-phase, L-G, L-L, L-L-G)
- Generator circuit breaker evaluation

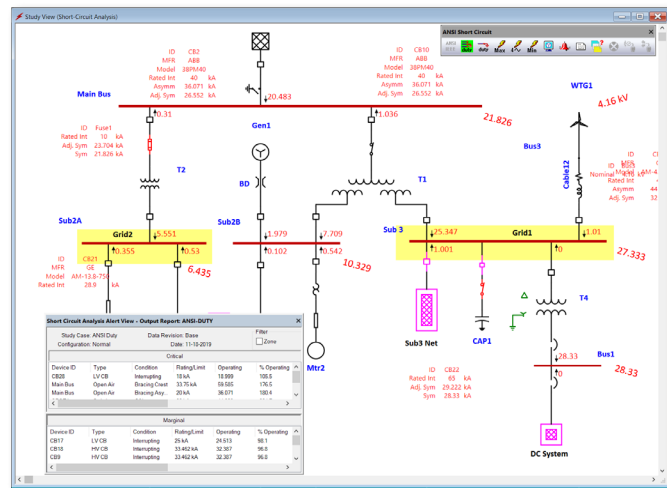

Distribution Short Circuit

Short circuit analysis for unbalanced network to study shunt, series, simultaneous, and sliding faults.

- Run & evaluate all fault types in one study
- Fault current as function of time with AC & DC decay
- Simulate protective device responses to fault currents & configuration changes

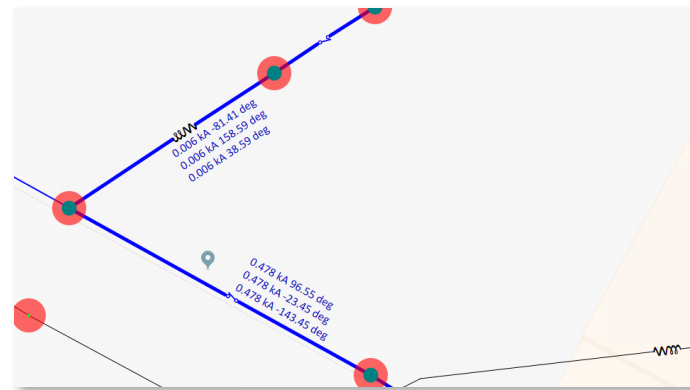

Fault Management Service Restoration

Analyze the impact of individual / simultaneous forced or planned outages and validate optimal switching plans to restore electrical power to affected customers.

- Gain insight to feeder reliability
- Minimize network losses
- Minimize the number of overloaded elements
- Identify post-fault restoration strategy
- Integral component of ETAP OMS™

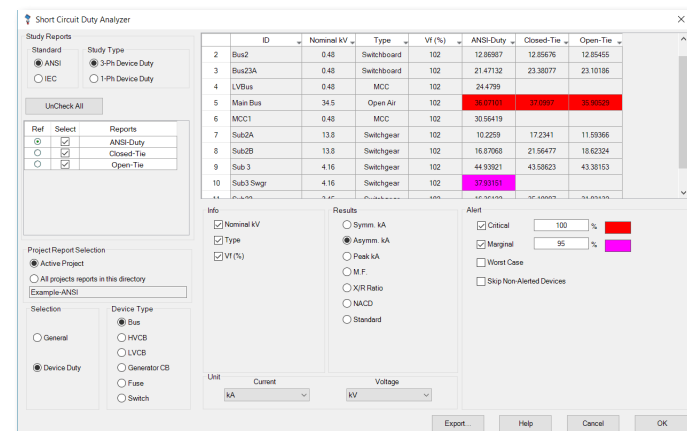

Balanced & Unbalanced Networks

IEC 60909

Determine fault currents, identify problem areas in the system and reduce risk by automatically comparing results against equipment ratings.

- User-definable voltage C factor
- Z adjustments for max/min I^r k & I_k
- Automatic application of K correction factors
- Meshed & non-meshed networks

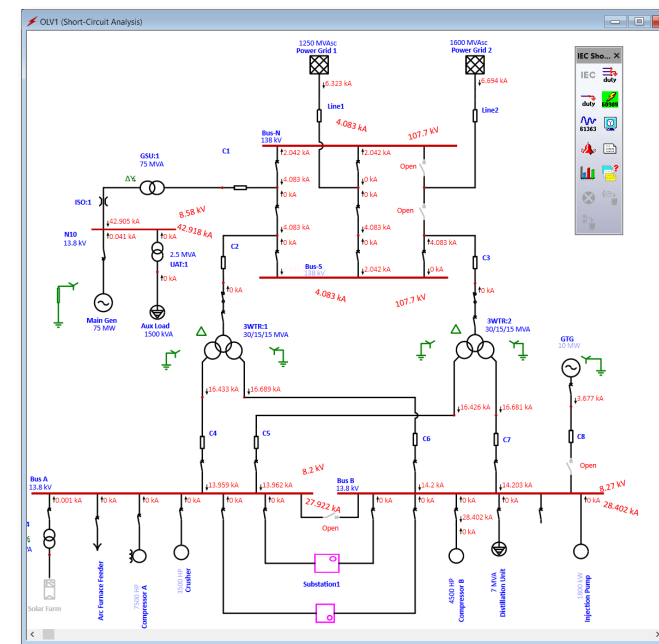

IEC 61363

Design safer Marine & Offshore electrical networks and improve system reliability.

- Transient fault analysis
- Device duty evaluation
- Consider preload conditions
- Alert visualization, tabulation & reports

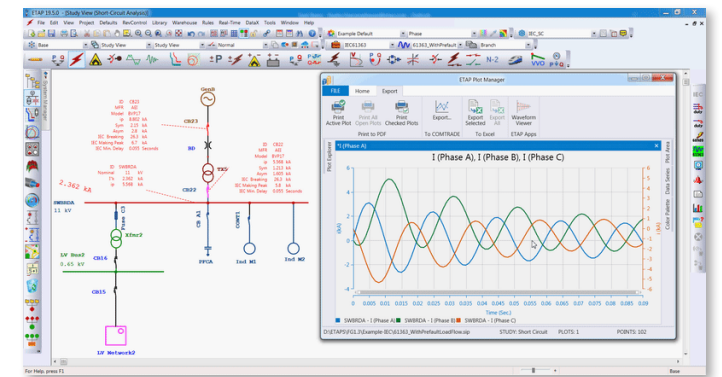

DC Short Circuit - ANSI & IEC

Evaluate system fault conditions and assess protective device ratings for direct current systems.

- ANSI / IEEE 946
- IEC 61660
- Fault current rising time
- Peak fault current, time constants, time-to-peak, steady-state conditions
- Battery & charger modeling per IEEE standard

GOST R-52735 & R-28249

Comprehensive fault analysis for HV & LV system based on the GOST standards.

- Calculate periodic & aperiodic components
- Consider pre-fault loading conditions
- Radial & multi-loop circuit calculations
- Short circuit output report in Russian language

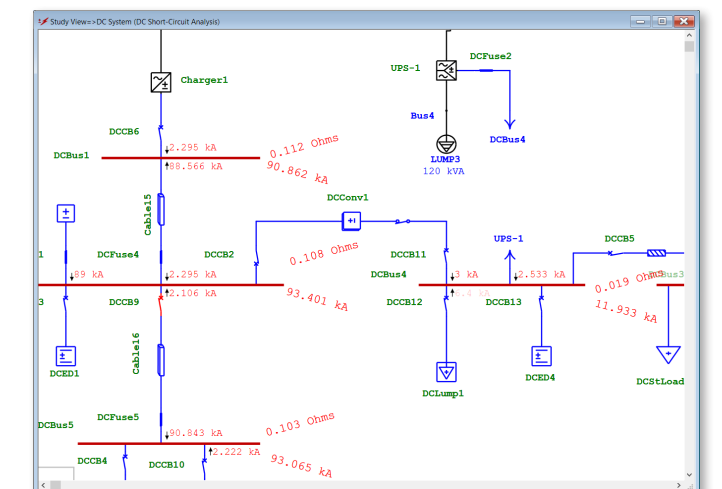

STAR™ Protection & Coordination

An intuitive and logical solution to enable system engineers to easily and efficiently perform protective device coordination studies and quickly realize possible design issues and make informed decisions.

- ✓ Graphical user interface & characteristics plots
- ✓ True-to-the-form protective devices modeling
- ✓ Integrated rule-based design & assessment
- ✓ Virtual animation of sequence-of-operation
- ✓ Embedded analysis modules
- ✓ Analyze system protection & mis-coordination
- ✓ Detailed device settings reports
- ✓ Extensive Verified & Validated device library

TOC Coordination & Selectivity

An intelligent and powerful tool for performing time-overcurrent protection and coordination studies.

- Time-Current Characteristic Curves – TCC
- Protection zone selection & viewer
- Zone Selective Interlock scheme – ZSI
- Detailed device setting reports

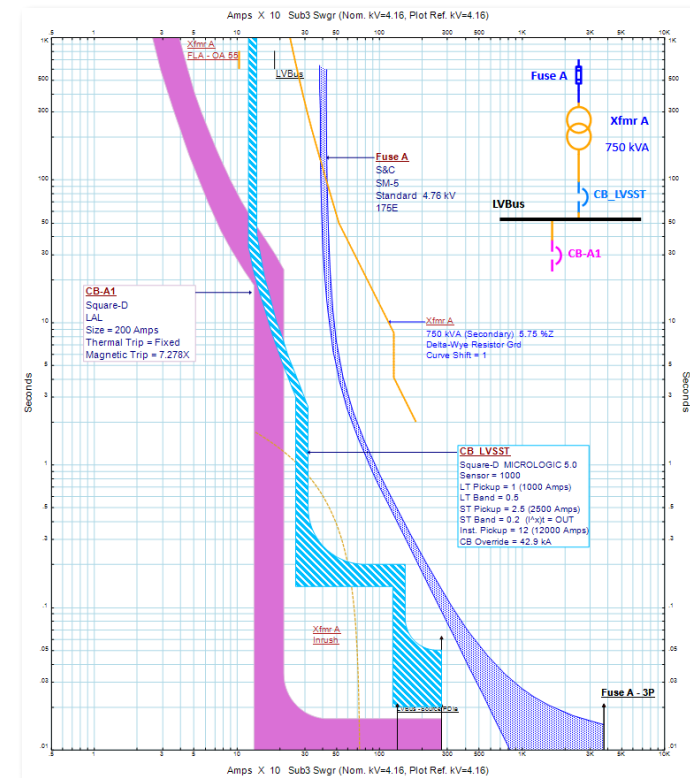

Sequence-of-Operation - SQOP

Evaluate, verify, and confirm the operation and selectivity of the protective devices for various types of faults for any location.

- Device failure & backup operation
- Normalized (shifted) TCC curves
- Sequence of events viewer

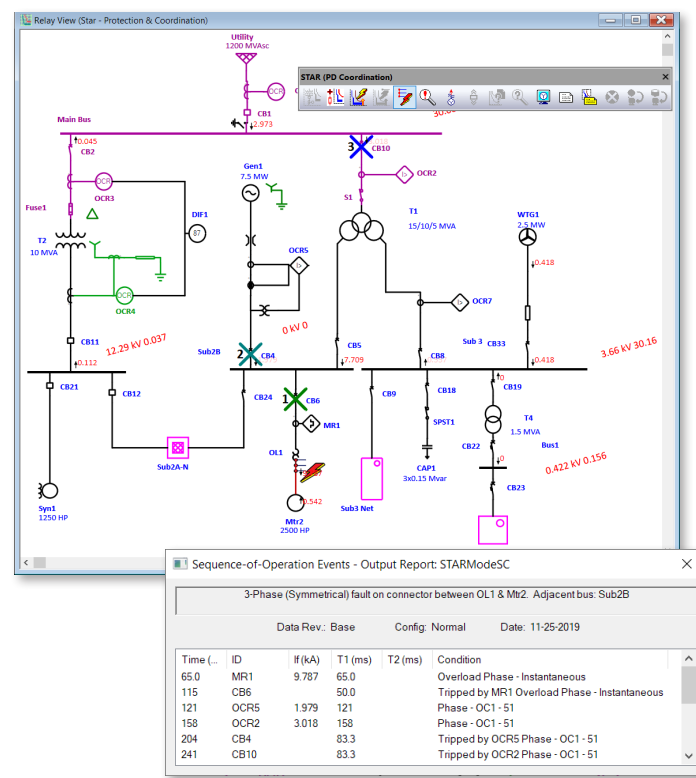

Graphically adjust device setting and insert faults to evaluate the state of protective devices

STAR™ Auto-Evaluation

Reduces months of work to a few hours with rule-based design and automatic protection & coordination evaluation.

Automated Protection & Coordination

- Automated & intelligent detection of protection zones
- Automatic selection of worst-case fault location
- Identify false tripping & miscoordinations
- Support of NEC, IEEE, IEC standards & guidelines
- Automated display of TCC & damage curves
- Graphical criterion violations & alert messages

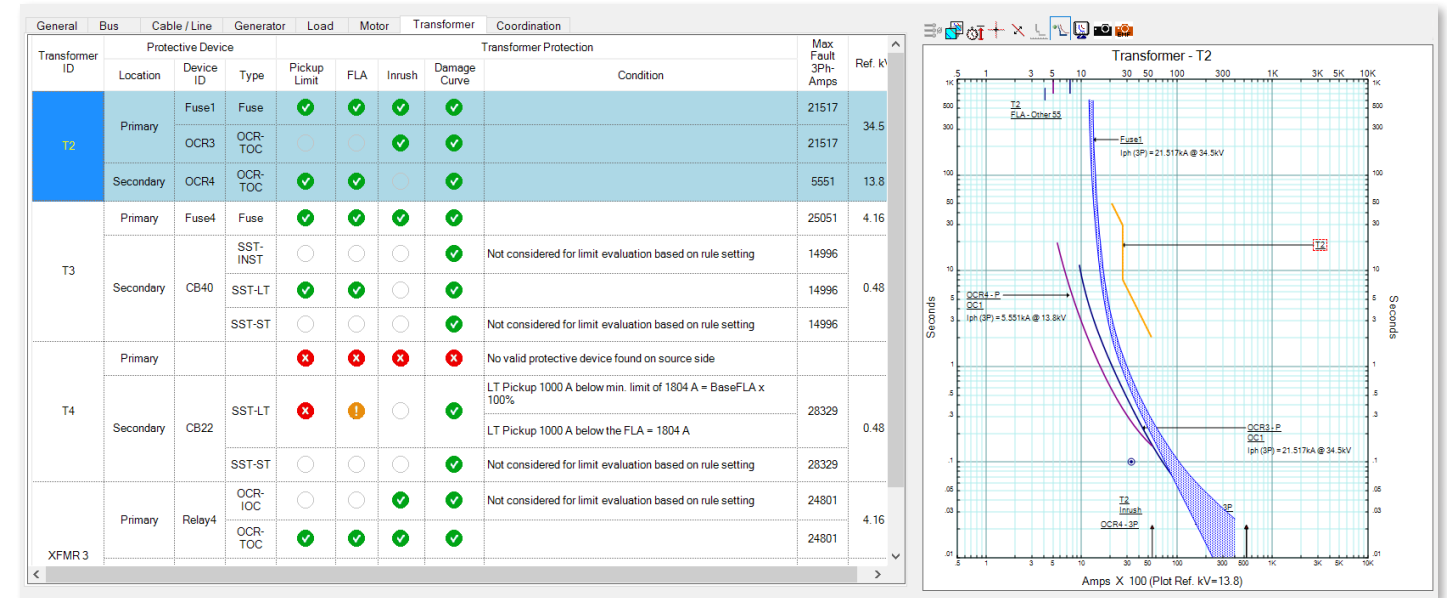

Boost productivity & save time with automated protection & selectivity

Device Settings Report

- Customizable device settings report
- Tabular export to Excel format
- Filtering & sorting based on substation / bus IDs

Bus / Substation ID	LVCB ID	Manufacturer	Model	Rating	Function	Setting	Delay	Band	Short Time / Ground	Instr. / Maintenance	Pickup	
SGR 104-2	CB 104-03	General Electric	ABB-301	1000	Phase	0.25	1000	4	3	4000	Min	5
SGR 104-2	CB 104-04	General Electric	ABB-301	1000	Phase	0.95	1000	4	3	4000	Min	5
SGR 2A	CB 100-30	General Electric	ABB-301	800	Phase	0.8	600	2	3	1000	Min	5
SGR 2A	CB 100-3C	General Electric	ABB-301	800	Phase	0.8	600	2	3	1000	Min	5
SGR 8	CB 100-3A	General Electric	ABB-301	800	Phase	0.8	600	2	4	2500	Min	7
SGR 8	CB 100-3B	General Electric	ABB-301	800	Phase	0.8	600	3	5	3200	Min	5
SGR 100	CB 100-3	General Electric	ABB-301	3200	Phase	0.8	2500	3	3	7000	Min	5
SGR 100-4	CB 100-4B	General Electric	ABB-301	800	Phase	0.8	600	2	3	1000	Min	5
SGR 100-4	CB 100-4C	General Electric	ABB-301	800	Phase	0.8	600	2	3	1000	Min	5
SGR 100-4	CB 100-4D	General Electric	ABB-301	800	Phase	0.8	600	2	3	1000	Min	5
SGR 100-4	CB 100-4A	General Electric	ABB-301	800	Phase	0.8	600	2	3	1000	Min	5
SGR 100-4	CB 100-4E	General Electric	ABB-301	3200	Phase	0.8	2500	3	3	7000	Min	5
SGR 100-2	CB 100-2C	General Electric	ABB-301	800	Phase	0.8	600	2	4	2500	Min	5
SGR 100-2	CB 100-2D	General Electric	ABB-301	800	Phase	0.8	600	2	4	2500	Min	5
SGR 100-2	CB 100-2A	General Electric	ABB-301	800	Phase	0.8	600	2	4	2500	Min	5

Protective Device Library

- Verified & Validated protective device libraries
- True-to-form modeling of protective devices
- Latest & legacy manufacturer models
- Customizable / User-definable libraries

Fuse	Solid State Trip
Relay	Electro Mechanical Trip
Recloser	Thermal Magnetic Trip
Electronic Controller	Motor Circuit Protector
HV Circuit Breaker	Overload Heater
LV Circuit Breaker	GFCI / RCD

StarZ™ Advanced Protective Device Analysis

Analyze and improve system-wide protection, troubleshoot false trips, and provide an accurate operating characteristic and state of protective devices under steady-state and transient actions.

- ✓ Reduce human error in relay settings & logic
- ✓ Simulate model-specific protection settings
- ✓ Advanced power flow & fault analyses
- ✓ Unified protection & dynamic stability
- ✓ Sequence-of-operation of protective devices
- ✓ Comprehensive relay library models

Characteristic Plot & Coordination

Accurately model and graphically represent relay functions, characteristics, and settings.

- Distance, Differential, Directional, Overcurrent, Load Encroachment
- Plot R-X characteristics & seen impedances
- User-editable scheme logic

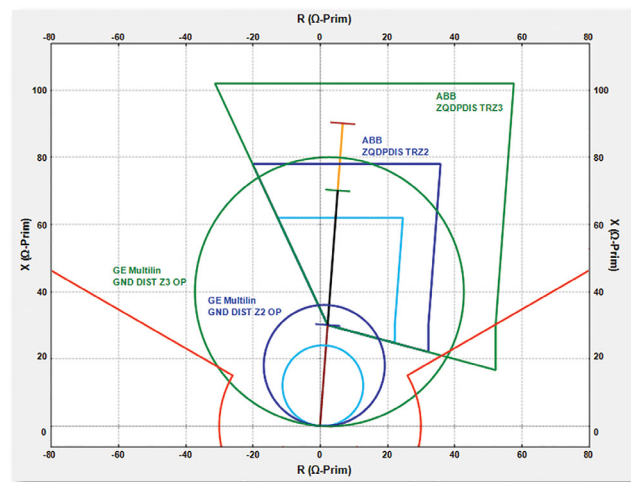

Unified Protection & Dynamic Stability

Simulate and verify protection settings, logics, and their dynamic interactions to ensure power system stability and grid code compliance.

- Out-of-step relay evaluation
- Loss-of-excitation simulation
- Seen impedance vs time & relay characteristic plots

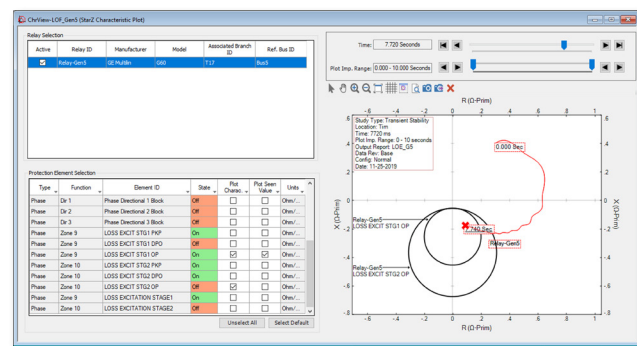

Fault Analysis & Line Loadability

Simulate and evaluate the performance of system protection and line loadability under various operating and fault conditions.

- Single & Sliding faults
- Load flow & transmission line loadability analysis
- Multiple fault locations analysis in one click
- Series compensated line evaluation with MOV action

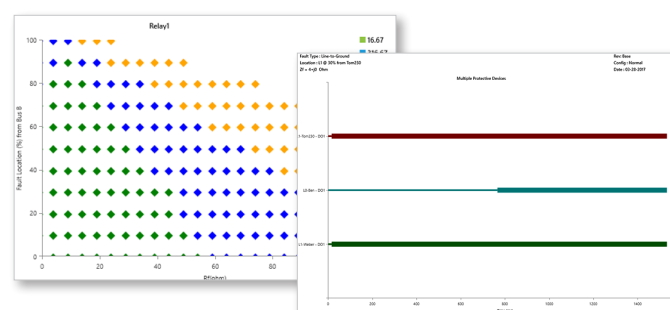

Plots & Settings Reports

An interactive diagnostic and time-saving plot assessment tool to provide comprehensive study deliverables.

- Time State plot
- Time Distance Characteristic plot
- Time Distance-Resistance Characteristic plot
- Detailed device settings reports
- Export relay settings to XML & Excel formats

eProtect™ Protection Asset Management System

Centralized protection asset management solution integrated with ETAP Protection & Coordination software to manage location, information and settings throughout the lifecycle of protective relays and substation assets.

- ✓ Increased data quality & access management
- ✓ Automatic processing & setting file generation
- ✓ Relay setting change management
- ✓ Protection system maintenance plan
- ✓ NERC compliance summary reporting
- ✓ Multi-user environment for relay management
- ✓ Relay settings tracking dashboard & notification
- ✓ Protection visualization & evaluation
- ✓ Health monitoring & maintenance
- ✓ Integrated with Automated Fault Analysis System

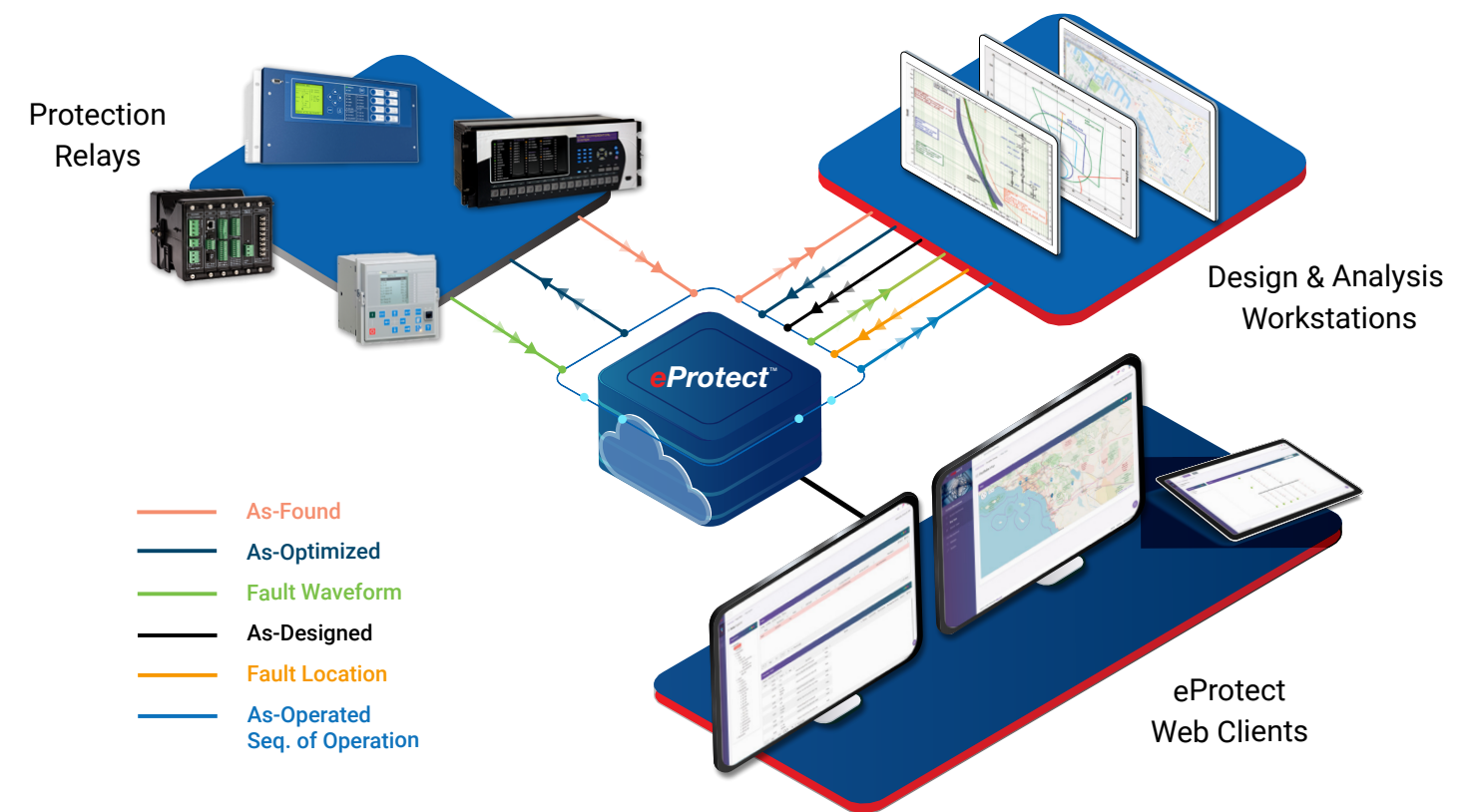

Data Exchange & Synchronization

- Automatically import the PD settings
- Download settings via FTP/SFTP/IEC 61850
- Upload settings to devices remotely
- Interface with vendor-provided software
- Import manually collected setting files
- Web interface accessible via mobile devices
- Data collection via etapAPP

Relay Settings Change Management

- Compare As-Found to As-Designed settings
- Auditing of studies & implementations
- Automatic notification of settings changes
- Make data commonly available from all sites to users
- Flexible and secured architecture

ArcSafety™ AC & DC Arc Flash

Improve safety, reduce risk, minimize equipment damage, and validate mitigation techniques using all-in-one solution AC & DC arc flash for LV & MV systems.

- ✓ Calculate incident energy at multiple locations
- ✓ Worst-case arc flash scenario evaluation
- ✓ Arc flash labels, study data sheets & work permits
- ✓ Hazard evaluation for shock protection & PPE
- ✓ Integrated with Star-Auto Evaluation & TCC views
- ✓ Identify mis-operation due to arc flash

AC Arc Flash

Identify and analyze high risk arc flash areas in electrical power systems with greater flexibility by simulating and evaluating various mitigation methods.

- IEEE 1584-2018
- NFPA 70E
- PPE requirements approval
- Customizable electrical work permits
- Safety labels in multiple languages

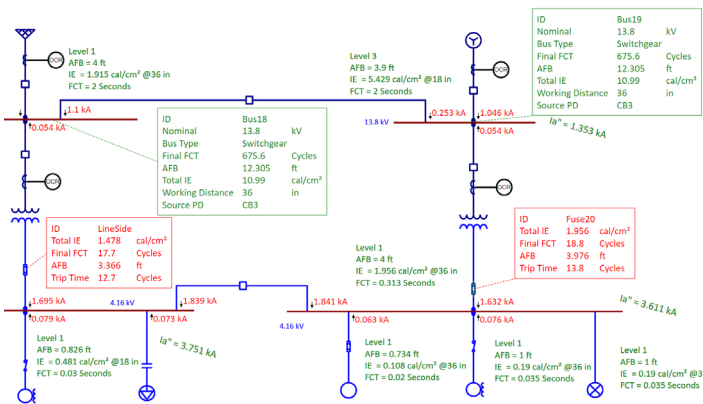

DC Arc Flash

Calculate the incident energy for direct current applications: mission critical facilities, substation battery banks, photovoltaic plants, nuclear plants, and transportation systems.

- Incident energy & shock protection boundary calculations
- Maximum Power, Stokes & Oppenlander, Paukert methods
- NFPA 70E 2018 Annex D.5.1 to D.5.3

Arc Flash Auto-Evaluation

Time-saving tool to automatically assess, evaluate, and graphically report arc flash incident energy levels at different fault locations.

- Automated arc flash energy evaluation
- Rule-based incident energy boundary evaluation
- Arc-damage point evaluation per IEEE C37.20.7
- Graphical evaluation with warnings & alerts

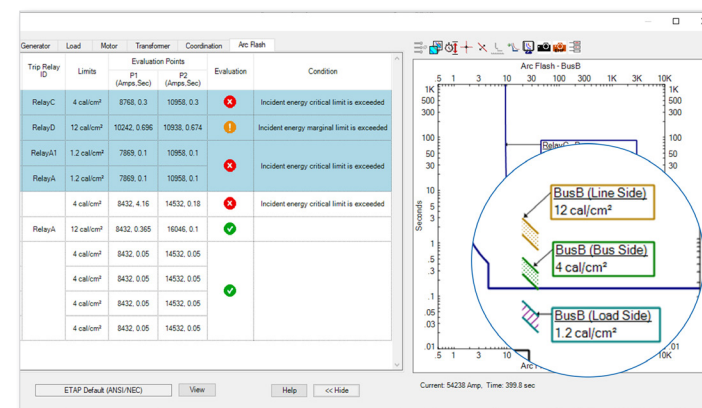

ArcFault™ High Voltage Arc Flash

Recommended solution for performing arc flash analysis at 15 kV and above for electrical transmission & distribution utilities and renewable systems.

- ✓ Automatic arc fault current & duration calculations
- ✓ Verified & Validated against industry standards
- ✓ Batch analysis & evaluation with a single click
- ✓ Graphical simulation of arc faults
- ✓ Open-air arcing fault evaluation
- ✓ Arc-in-a-box for enclosed equipment

High Voltage Arc Flash

Arcing fault hazard evaluation for high voltage systems automatically determines the working distance and minimum approach distance based on the system voltage, transient overvoltage conditions, and altitude.

- OSHA 1910.269
- National Electrical Safety Code - NESC
- LG, LL, 3-phase arc faults
- Arc-in-a-box - 15 kV to 36 kV
- Applicable for 1 kV to 800 kV

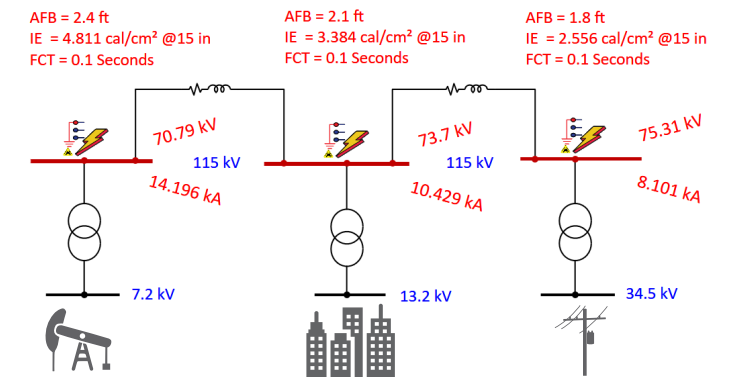

Result Analyzer

Compare and filter multiple arc flash analysis results from different cases in a single display and determine the worst-case scenario.

- Multi-report result analyzer
- Tabular display of arc flash results per energy levels
- Export customized results to Excel
- Color code & filter results by various categories

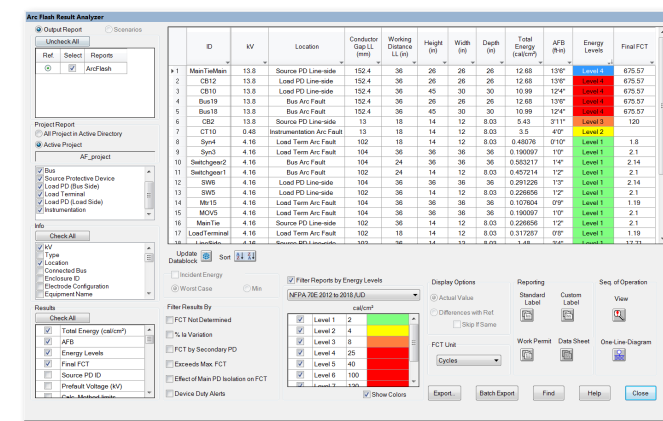

Arc Flash Calculators

Powerful graphical tool for rapid assessment of multiples or batches of 'what if' scenarios.

- IEEE 1584-2018
- IEEE 1584-2002 CL Fuse & Breaker
- DC Arc Flash
- High Voltage Arc Flash – OSHA, NESC
- BGI / GUV 5188E - German standard
- ENA NENS 09-2014

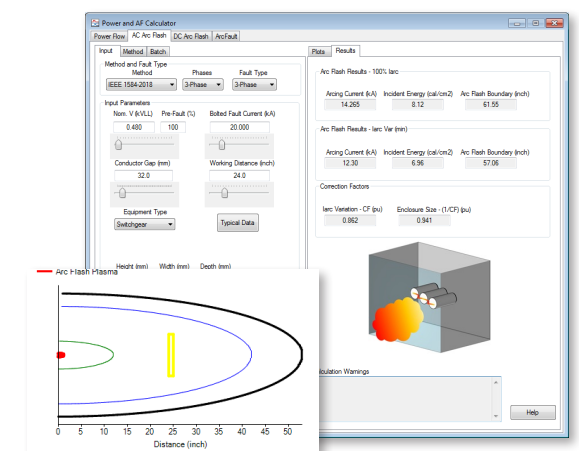

Renewable Energy

Renewable power source modeling and analysis for accurate simulation, equipment sizing, grid interconnection studies and field verification of wind and solar farms.

Wind Turbine Generator

Model and simulate wind farms & parks under steady-state and dynamic conditions and study their impact on the power grid.

- Element modeling included in core module
- Simulate transient wind disturbance; ramp & gust
- WECC wind turbine dynamic models & types
- Dynamic models based on IEC 61400-27-1-ed1
- Turbine manufacturer & model library

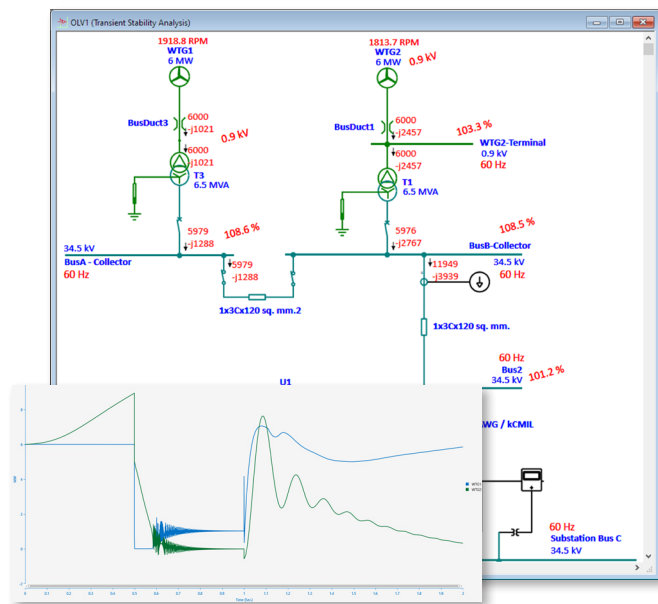

Photovoltaic Array

Design, size, and simulate PV arrays and analyze the impact of solar farms on the distribution grid as DER.

- Detailed solar panel & farm modeling
- Solar irradiance based on location & time
- Inverter current limit modeling & operation modes
- Equivalent PV modeling for grid interconnection studies
- Manufacturer nameplate library data; P-V & I-V curves
- Solar PV Parameter Estimation

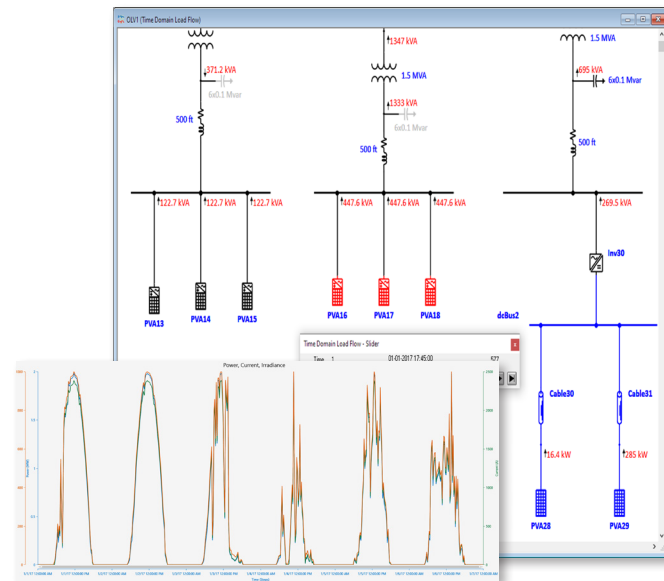

Controller

Design, optimize, and test the performance and response of the microgrid controls for various generation contingencies and loading variations to allow for faster and validated field deployment.

- Modeling & simulation of Distributed Energy Resources
- Graphical & scripting tools to develop & test logics
- Built-in logics for dispatch, islanding & load forecasting
- Validate controller logic with ETAP Software-in-the-Loop
- Automated predictive simulation
- Controller network parameter inputs to UDM
- Integrated with SCADA, ADMS & DERMS

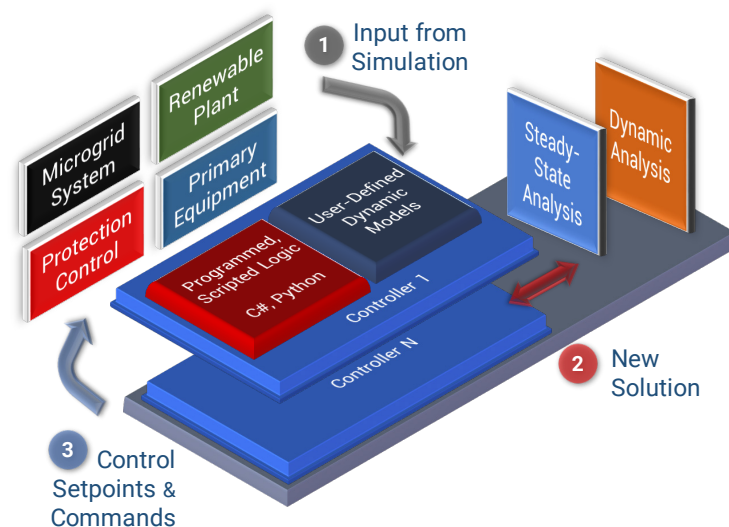

Energy Storage Systems

Select the most appropriate battery bank, verify the maximum capability, and easily simulate a wide range of backup, control and other scenarios.

Battery Sizing

Quickly and efficiently size the number of battery strings and cells for a designated duty-cycle compensated for real-life variables.

- IEEE 485 standard
- Integrated AC & DC Control System Diagrams
- Voltage drop & loss consideration
- Plot bus voltage & load & branch flow
- Battery sizing reports
- Battery manufacturer & model library
- Correction factors for temperature, aging & margins

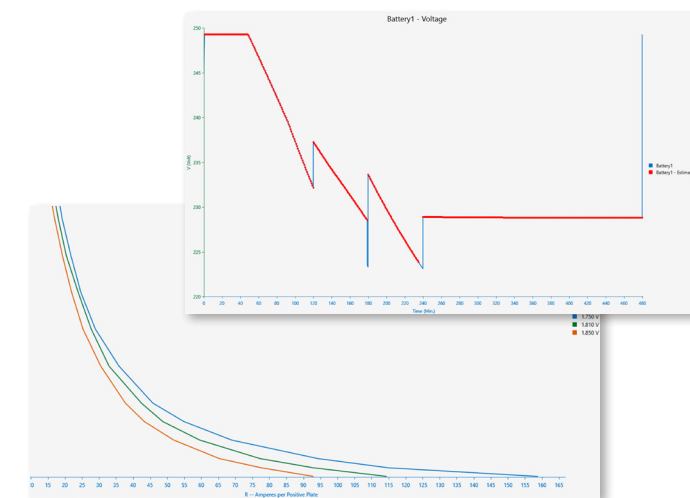

Battery Discharge

Verify the performance of the battery duty cycle and capacity by simulating operating situations, such as shutdowns and emergency conditions.

- IEEE 308 & 946 standards
- Discharge via DC load flow & duty-cycle simulation
- Class 1E DC power & control system models
- Simulation of control system with battery discharge
- Load model type per operating characteristics
- Plot battery capacity, voltage & current
- Battery characteristic curves

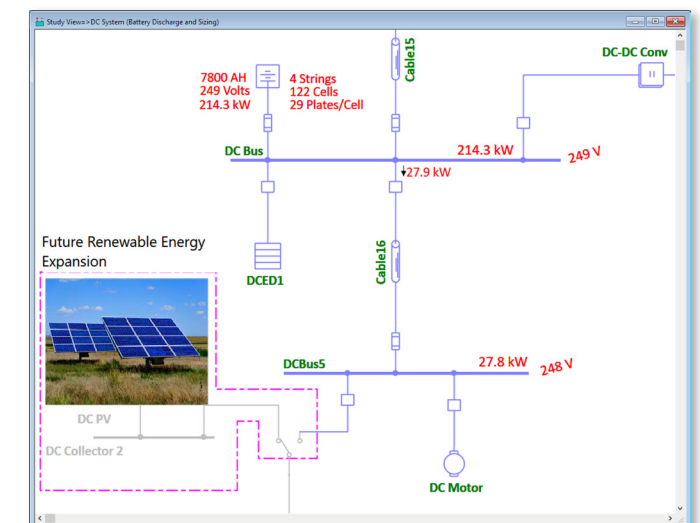

Energy Storage Devices

Apply optimal charging, discharging and arbitrage to improve system efficiency and maximize profits with modern energy storage devices to support the grid modernization requirements.

- Intelligent battery parameter estimation
- Lithium-Ion & Lead-Acid battery types
- Optimal charging, discharging & arbitrage
- Behind-the-meter and front-of-meter applications
- Frequency, voltage, ramp & demand responses
- Battery Management System - BMS

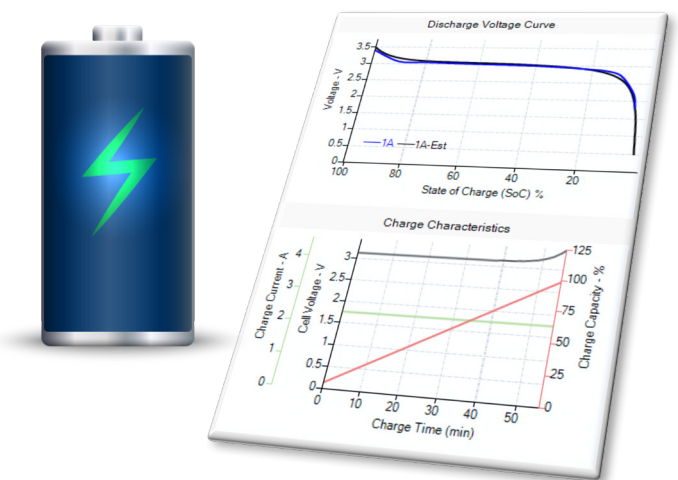

Network Analysis

A comprehensive set of integrated power system analysis modules for simulation, prediction, design, planning, visualization, and situational awareness.

Motor Acceleration

Calculate and evaluate motor acceleration time, voltage impact of motor starting and load transitioning on electrical power systems with accurate modeling of machines, loads, starting devices.

- Multiple motor / load acceleration, stop & sequencing
- Load & generation transitioning
- Comprehensive graphical & tabular alerts
- Include transformer LTC / voltage regulator action
- Reporting & result validation
- Motor Starting Result Analyzer

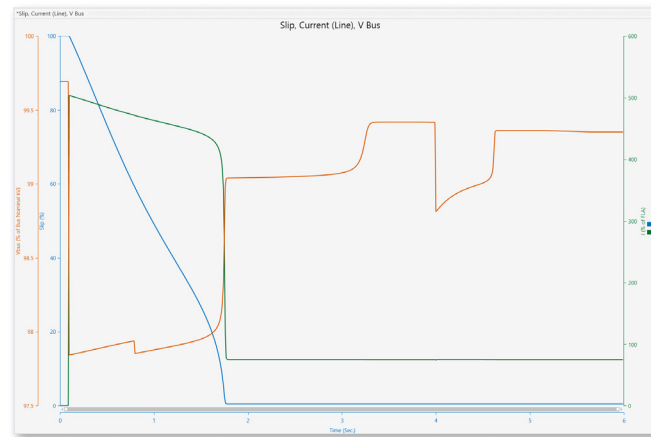

Load Allocation

Analyze and determine system-wide technical & non-technical losses using automatic demand meter reading and advanced algorithms.

- Daily kWh
- Monthly kWh
- Transformer kVA
- Real consumption - REA method

Voltage Stability

Automatically analyze multiple load growth scenarios and understand the stability margins available using a holistic network simulation to improve network security and system loadability.

- Sensitivity analysis
- P-V, Q-V analysis or continuation load flow analysis
- P-V curves, V-Q curves, dV / dQ self-sensitivities
- Graphical result evaluation & plots

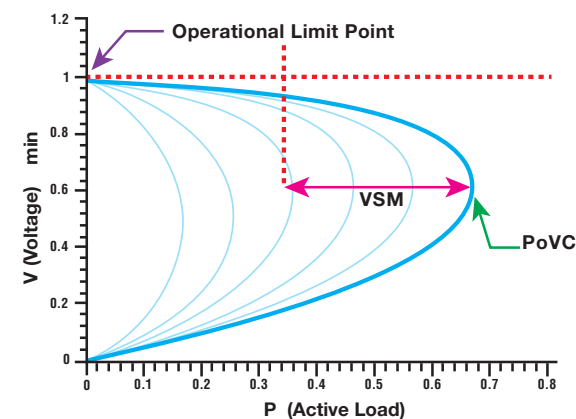

Grid Code Compliance

Quickly check & validate grid code compliance against industry & regional regulations.

- Grid Impedance Locus
- Perform LFRT & HFRT Dynamic Studies
- Frequency Ride-Through Compliance Studies

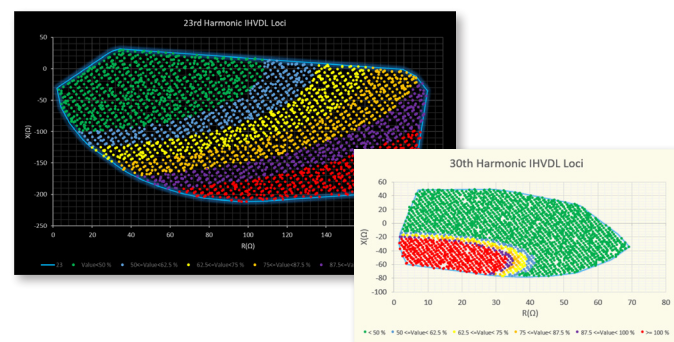

Integrated & Powerful Simulations

Harmonics

Simulate harmonic current and voltage sources, identify harmonic problems, reduce nuisance trips, design and test filters, and report harmonic voltage and current distortion limit violations.

- IEEE 519-2014, IEC 61000-3-14, IEC 61000-3-6
- Harmonic load flow
- Frequency scan analysis
- Voltage flicker limitation studies
- Resonance condition identification & alerting
- Frequency dependent modeling
- Harmonic filter design & sizing
- Automatic distortion evaluation
- Inter-harmonic simulation
- Distortion indices calculation
- Harmonics plots & report

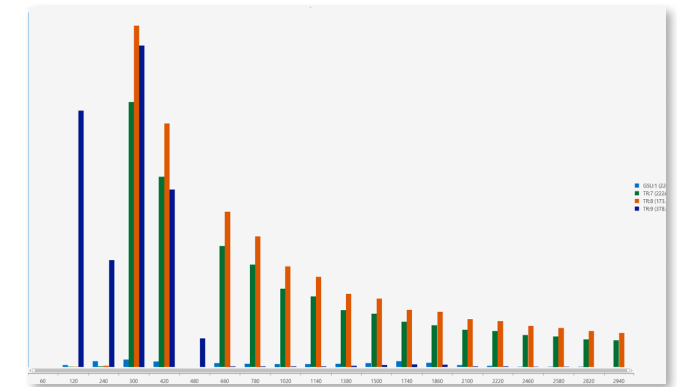
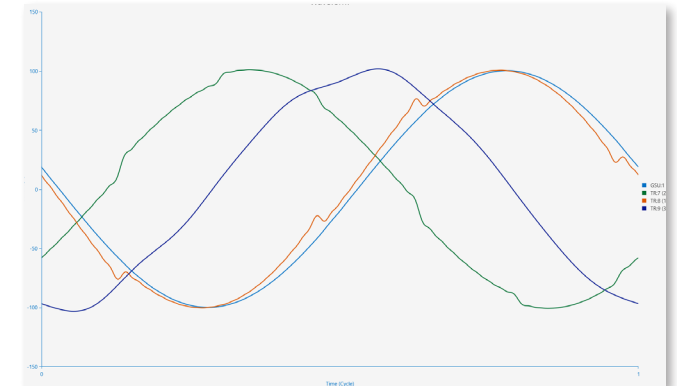

Reliability Assessment

Efficient and effective reliability assessment of the availability and quality of power throughout the system.

- Unbalanced system reliability calculation
- Customer-oriented indices
- Energy (cost) indices
- Sensitivity analysis
- Single & double contingency
- Looped & radial systems

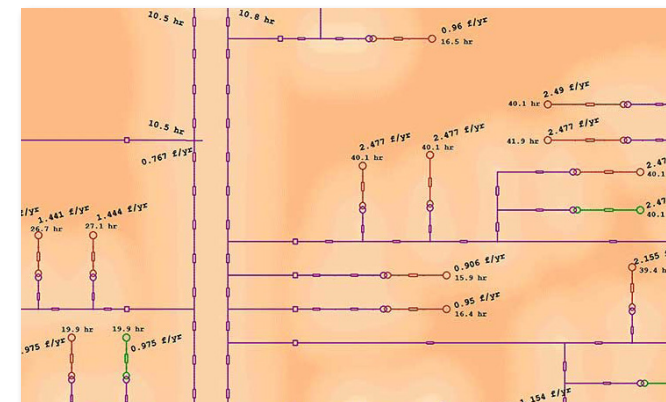

Contingency Analysis

Analyze, rank, and visualize thousands of component outage and failure contingency scenarios in just minutes.

- N-1 & N-2 contingency assessment & ranking
- Fast screening method to scan outage list
- Multiple graphical outage lists
- Automatic performance indices calculation
- Summary report analyzer

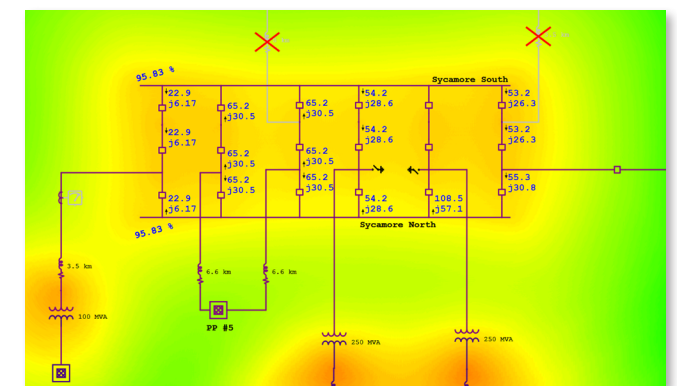

Dynamics & Transient

Simulate sequence-of-events, actions, and disturbances to evaluate system stability and transients by utilizing accurate power system dynamic models with complex machine control block diagrams and systems.

Transient Stability

Perform, fast bus transfer, motor dynamic acceleration/re-acceleration, critical fault clearing time, load shedding studies and more.

- Typical & common disturbances & operations actions
- Transient simulation action for various fault types
- Simulate split system & combine multiple subsystems
- Automatic relay actions per settings & system dynamics
- Auto-sync-check action
- Transformer inrush simulation

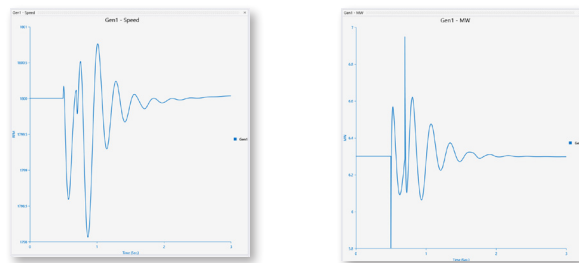

Electromagnetic Transients

eMT™ - A dedicated Electromagnetic Transient Program for simulation and analysis of power system transients.

- Switching transients & surges
- Insulation coordination
- Lightning surges & protection
- Torsional stress & sub-synchronous oscillations
- Transient Recovery Voltage studies
- FACTS & electronic converters

eMTCoSim™ - Co-simulation of Electromagnetic and Phasor domains

- Hybrid simulation of Transient Stability & eMT
- Simulate large network sections with high-fidelity
- Co-simulate at msec & μ sec time steps
- Analyze coupling between phasor & EMT domain
- Live Plots for Transient Stability & EMT simulation
- Automatic Network & Components Mapping to eMT

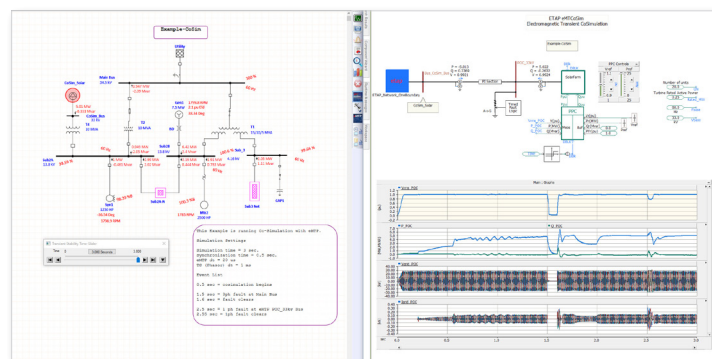

Generator Start-Up

Analyze cold-state starting of generators under normal and emergency conditions using full frequency-dependent machine and network models.

- Cold-state generator starting
- Load generators prior to synchronous speed
- Frequency-dependent machine & network models

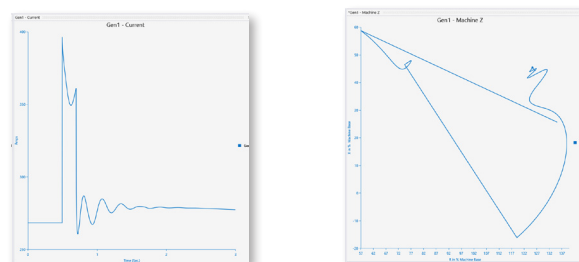

Dynamic Modeling & Tuning

Dynamic Parameter Estimation & Tuning

Intelligent time-saving and validation tool to automatically adjust and tune control system parameters to match actual field measurements.

- Compliance with NERC MOD-026 & MOD-027 standards
- Obtain best-fit model parameters to measured data
- Plot sensitivity, measured vs. calculated values
- Result analyzer & input / output data comparator

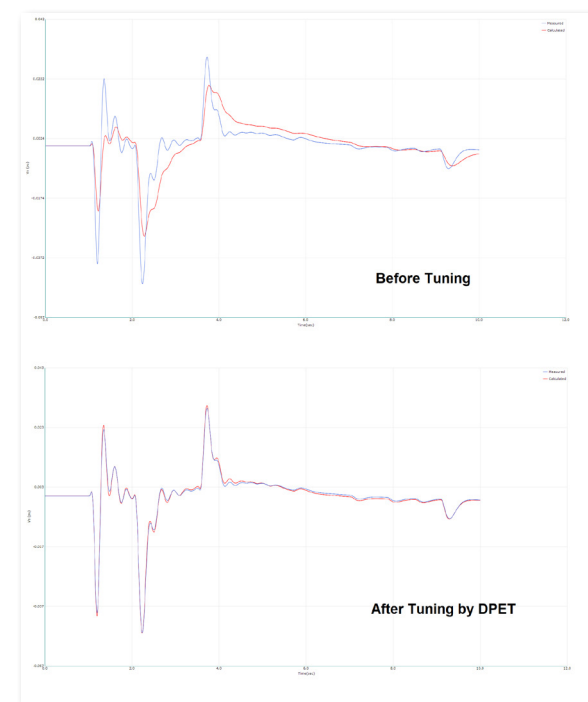

Machine Parameter Estimation

Calculate equivalent circuit model parameters for machines at starting condition based on advanced mathematical estimation and curve fitting techniques.

- Estimate induction machine equivalent circuit models
- Parameters based on manufacturer data & curves
- Single-cage models with rotor deep-bar effects

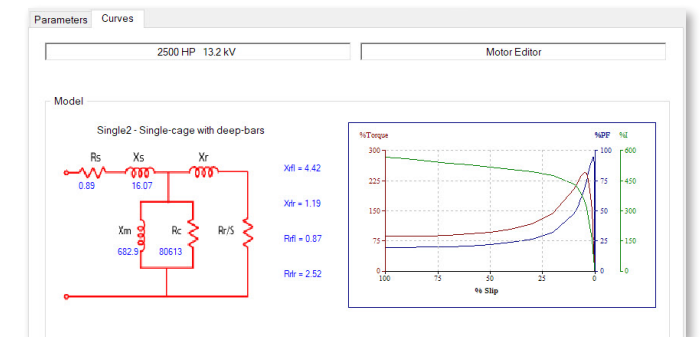

Dynamic Modeling

Dynamic models with User-Defined Dynamic Models (UDM) or Manufacturer Black Box Models (DLL).

- Built-in & User-defined dynamic models
- Frequency-dependent models
- Generator, WTG, Motor, Load
- Governor, Exciter, PSS
- HVDC, SVC, FACTS
- Converters
- Energy Storage Devices
- DLL-based dynamic models

User-Defined Dynamic Modeling

Build custom control block diagrams needed to simulate the dynamic behaviors of machines and loads.

- Graphical model builder
- Wide variety of blocks for building models
- Fast & accurate model initialization & testing methods
- Plant level control system simulation
- Hardware-in-the-Loop integration & testing
- Self-testing for model validation
- Dynamic responses to power system disturbances
- Library of verified & validated UDM models

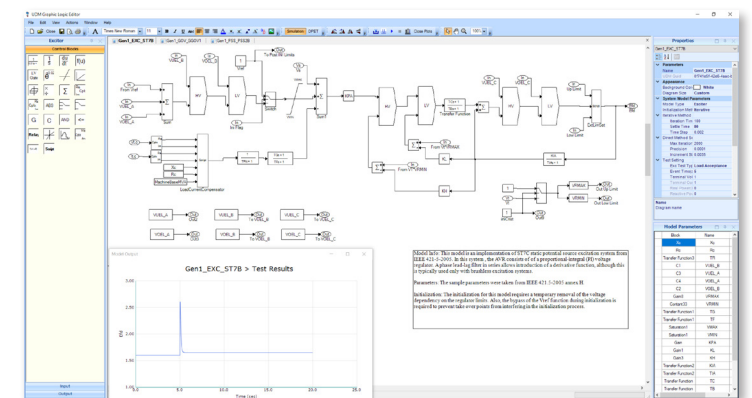

Transmission Line | HVDC Link

Integrated overhead lines and High Voltage Direct Current (HVDC) Transmission Link software for T&D system design and planning.

Overhead Line Impedance Calculation

Efficiently design, size, and verify transmission and distribution line parameters.

- Conductor & ground wire libraries
- Built-in configurations: horizontal, vertical, etc.
- General configuration: X, Y & Z coordinates
- Multi-line mutual coupling
- Transposed & untransposed lines
- Short & long line models
- Calculated or user-defined impedances

Sag & Tension

Perform sag and tension calculations to ensure adequate operating condition for the lines.

- Sag / tension vs. temperature
- Multiple spans between dead-end structures
- Level spans of unequal length
- Solve spans on different horizontal planes
- Include effects of wind, temperature & k factor

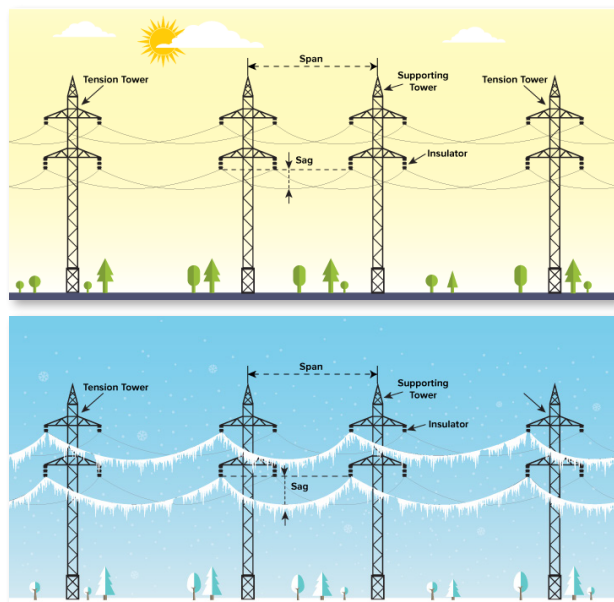

Line Ampacity

Calculate the derated ampacity of lines under various operating conditions based on current-temperature characteristics.

- Conductor ampacity vs. temperature
- IEEE 738 standard
- Determine maximum operating temperature for various loading conditions
- Derated ampacity based on temperature limit
- Consider weather, solar heat & geographical location

HVDC Transmission Link

Model and simulate HVDC link and converter technologies for steady-state and dynamic behavior of AC / DC networks.

- Detailed rectifier & converter modeling
- Composite AC / DC, DC / AC systems
- Built-in control schemes
- Inclusive transformer model
- Automatic harmonic spectrum calculation
- Easy-to-use integrated model
- VSC-HVDC model*

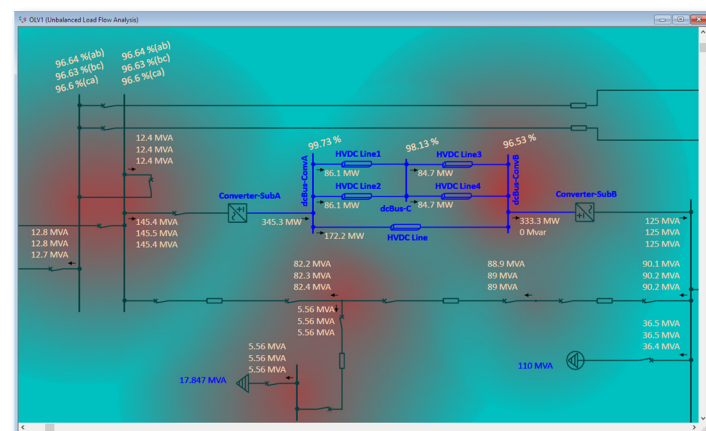

Cable Systems

A powerful suite of cable system solutions to save time, improve calculation accuracy, and accelerate the design to operate cables to their maximum potential while providing a secure and reliable operation.

Cable Ampacity & Sizing

LV & MV cable analysis and batch sizing tools to ensure compliance with industry standards.

- IEEE 399
- IEC 60502
- IEC 60364
- NF C 15-100
- ICEA P-54-440
- IEC 60092
- NF C 13-200
- BS 7671
- NFPA 70 - NEC
- AS/NZS 3008

Underground Thermal Analysis

Design and perform thermal analysis for cables in underground raceway systems to operate to their maximum potential capacity.

- Neher-McGrath
- IEC 60287
- Steady-state temperature
- Transient temperature calculation

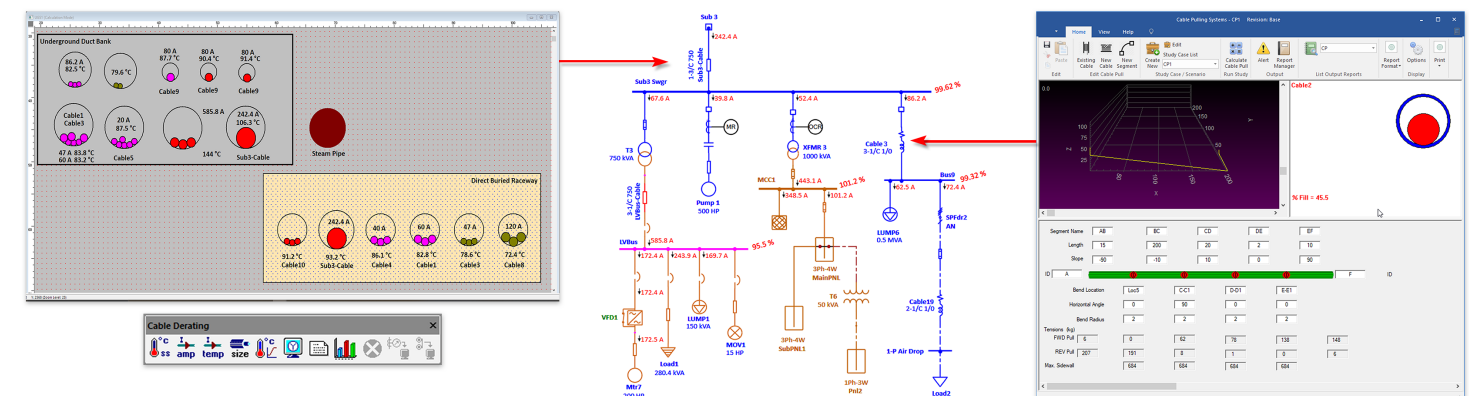

PE Conductor Sizing

Perform proper sizing of earth conductors in compliance with industry guidelines and regulations.

- PE thermal requirements & sizing
- User-defined fault current & clearing time
- Consider leakage current

Electric Shock Protection

Determine the cable current carrying capacity, size, and protection against electric shock.

- TN-C, TN-S, TN-C-S, TT & IT Earthing
- Loop impedance & current calculation
- Touch voltage calculation & evaluation
- Consider resistance to ground / earth

Power Transformer

Conduct transformer studies and assessments with transformer inrush simulation, transformer tap optimization, and transformer sizing analysis.

Transformer Sizing

Transformer rating and impedance sizing tool based on altitude, temperature, insulation, number of phases, and cooling stages.

- ANSI & IEC standard types, classes & ratings
- Transformer MVA sizing based on cooling stages

Transformer Tap Optimization

Determine the optimal transformer turns ratio to deliver maximum reactive power output.

- ANSI / IEEE C57.116 standard
- Optimize unit transformer turns ratio
- Considers system voltage variation
- Considers generation station auxiliary load
- Generator reactive capacity vs. voltage plots

Transformer Inrush

Evaluate transformer inrush current and its impact on the system.

- Inrush simulation using magnetization characteristics
- Sympathetic inrush - single & multi-transformer
- Verified & Validated calculations

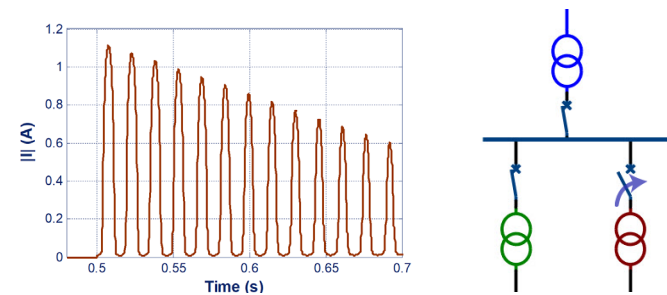

Sympathetic inrush for single & multi-transformer

DataX™ Data Exchange & Conversion

Improve productivity using data exchange tools and interfaces from standard or proprietary formats.

Autodesk Revit®

Simplify design, reduce cost, and validate Revit Electrical BIM with ETAP using enhanced time-saving data exchange features and analysis capabilities.

- Validate Revit Electrical BIM with ETAP
- Direct two-way communication
- Intelligent default auto mapping & interface
- Export simulation results
- Smart Connect: Revit plug-in to ETAP

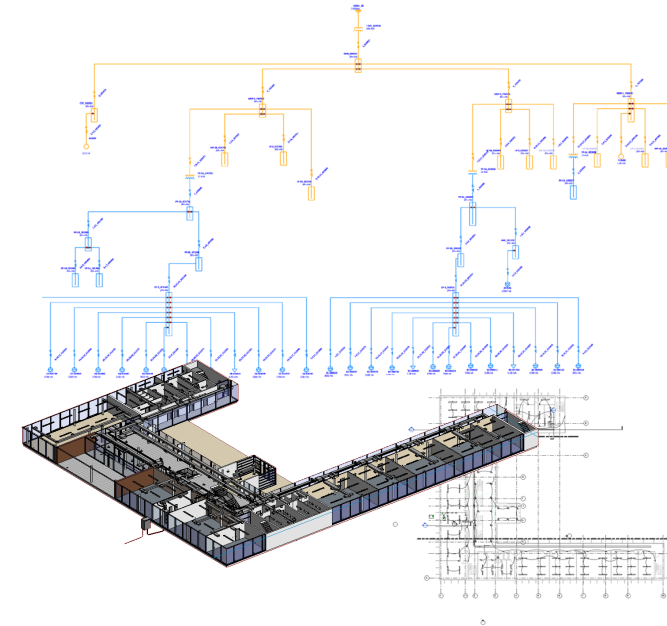

etapPy™

Feature-rich ETAP scripting and study automation using Python™ language.

- Integration of ETAP & Python scripting language
- API to batch run studies & generate output data reports
- Run studies remotely & in parallel across machines
- Built-in Python Script IDE or Editor

Universal Mapping

- Element & property mapping to 3rd party software
- Customizable logics & functions for electrical attributes
- Pre-defined math & power functions
- Supports CIM, ESRI ArcGIS, MultiSpeak, Excel

Microsoft® Excel

- Bi-directional Excel data exchange
- Map Excel worksheets to ETAP elements
- Perform consistency checks during data exchange
- Substitute incomplete data with defaults & library data

MultiSpeak™

- Import & export power system data
- User-defined mapping of elements & properties
- Supports MultiSpeak v3.0 & v4.0

Common Information Model - CIM

- Import & export data from ETAP using CIM XML
- User-defined mapping of elements & properties
- IEC 61970 & IEC 61968 standards
- Common Grid Model Exchange Specification (CGMES)

Import from Legacy Software

ETAP offers conversion tools from other power system analysis software that will automatically generate a multi-layered graphical one-line diagram in conjunction with the electrical data and associated TCC studies where possible.

Control Schematics

Detailed representation and simulation of operation-sequence for control systems.

DC Control System

- Simulation of operation sequence-of-control devices
- Pickup & dropout voltage calculation
- Burden & inrush modes
- Integrated with battery discharge calculation
- Automatic alerts

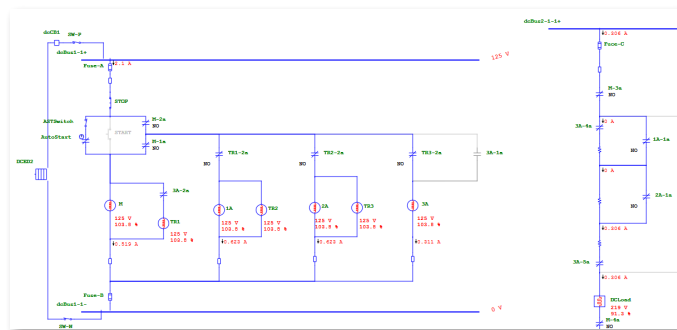

AC Control System*

- Interfaces with AC control power transformer
- Voltage drop calculation for each time step
- Controlled contacts with interlock logics
- State engine with automatic step-by-step simulation
- Sequence-of-operation of controls & switching actions

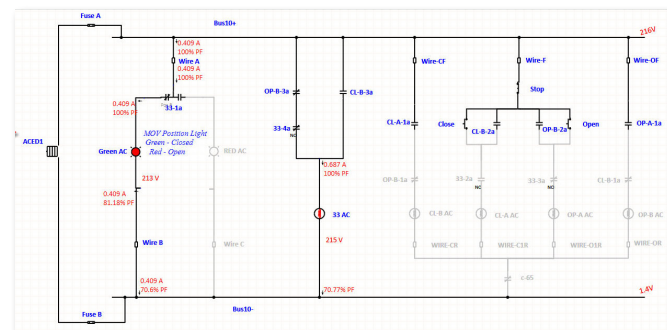

eTraX™ Rail Traction Power System

eTraX™ is utilized by designers, planners and owner / operators for analyzing and managing low and medium voltage AC & DC rail power.

- ✓ Design & study system behavior & operation
- ✓ Determine energy consumption of train services
- ✓ Analyze capacity of traction power supply
- ✓ Simulate contingencies & evaluate mitigations
- ✓ Rolling stock evaluation & comparison
- ✓ Effect of energy storage & regenerative braking
- ✓ Improve reliability of traction power systems
- ✓ Model unplanned events and future growth
- ✓ Verified & Validated against industry benchmarks
- ✓ eSCADA for real-time predictive simulation

AC & DC Railway Simulation

Simulate and analyze operation of combined DC and AC power supply networks.

Traction Equipment Modeling

Model traction power systems using synchronized geospatial and schematic views.

Equipment & Libraries

Built-in components and engineering libraries including traction rectifier, train rolling stock, and traction power equipment.



DC metros, AC suburban, high-speed rail, freight/mining, inter-city, light rail, automated people movers

Design to Real-Time Operation

Train Performance Calculations

Accurate calculation of train running times under normal or temporary speed restriction conditions considering track bend radius, rolling stock utilization, track section elevation, and more.

- Determine tractive effort based on train performance
- Track profile: grade, curvature, speed limits
- Identify power supply inadequacies & pinch points
- Train power consumption & demand
- Simulate rolling stock retrofits & upgrades
- Analyze train trip times
- Rolling, acceleration & drag resistance
- Trip stops & stopping patterns
- Impact of regenerative braking
- Voltage dependent locomotive modeling

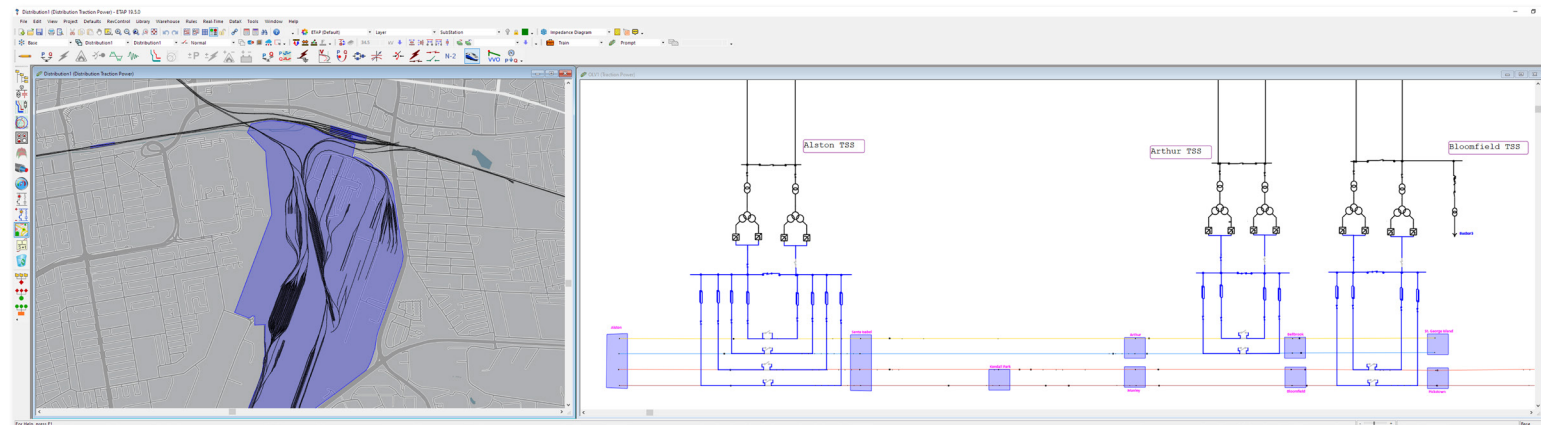

Geospatial Track Modeling

Visualize geospatial assets including tracks, overhead catenary system and traction substations.

Train Configuration & Time Schedule

Define, organize, and assign Train Consists to a train timetable.

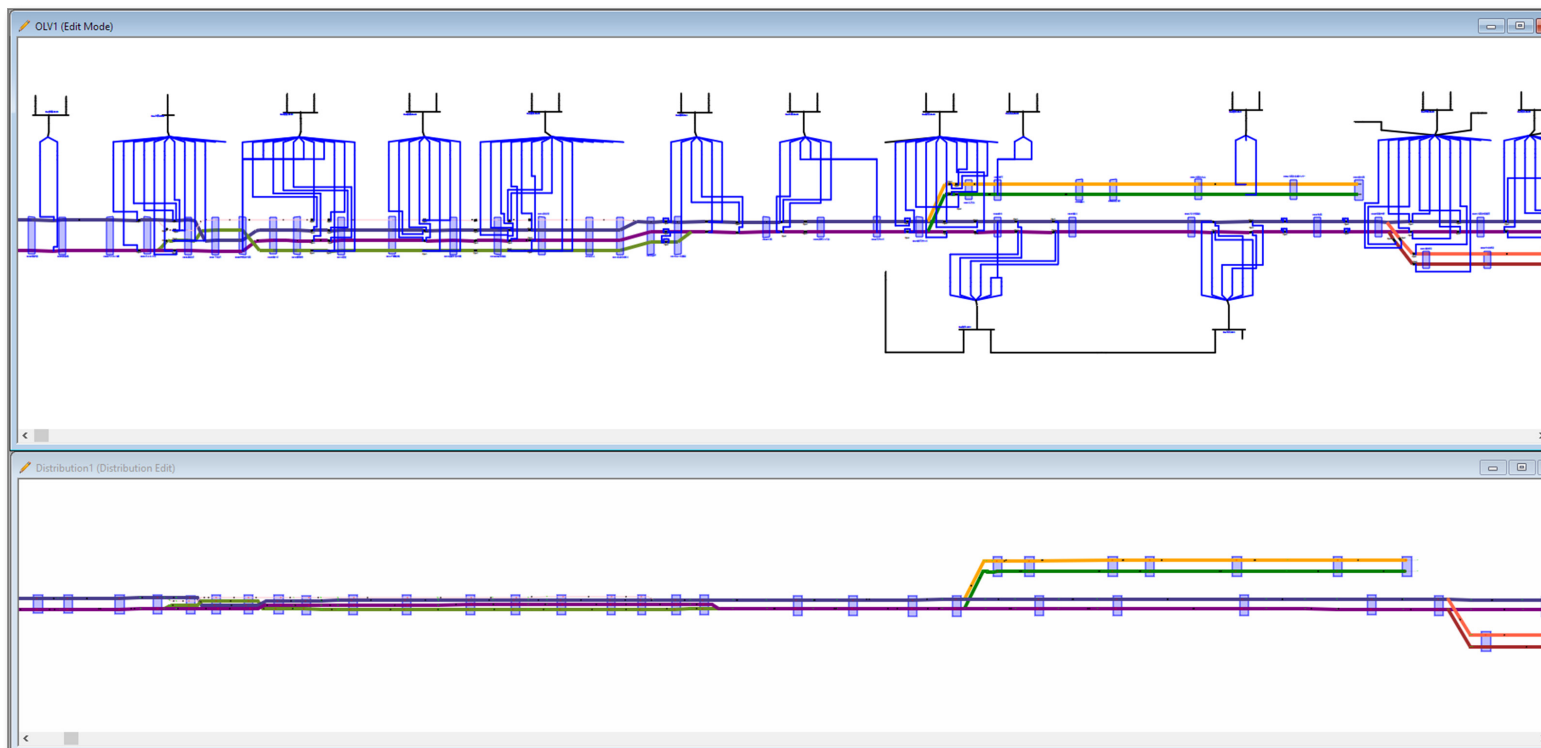

Traction SCADA & Power Management

Connect electrical design model with real-time analytics.



Multi-physics simulation of train mechanical energy & electrical demand in a single-Unified solution

A complete operation solution for continuous monitoring, predictive simulation, optimization, and automation of electrical power systems.

Model-Driven Enterprise Solution

A fully integrated enterprise power management solution that expands with your needs from modeling to operation.



Model-driven monitoring provides an intuitive real-time visualization and analysis platform via intelligent graphical user interfaces, one-line diagrams, geospatial views, and digital dashboards.

Visualization & Dashboards

SCADA HMI provides a modern graphical dashboard with electrical intelligence and situational awareness. Smart visualization views, combined with predictive analytics, enable the system dispatcher to effectively view and analyze key performance indicators.

Web & Mobile Views

Access data via mobile views and applications capable of connecting to multiple ETAP Real-Time Servers and Workstations. Monitor and analyze the system from anywhere using web-based HMIs.

Data Trending

User-friendly and flexible trending application that supports real-time as well as archived data trending.

Alarming & Notification

Embedded notification system to prioritize alarms and events via graphical and tabular views for early detection of problems before a critical failure takes place. Metered and non-metered alerts based on equipment rating and capability.

Event Logging

Data acquired from monitoring devices is recorded and logged to provide a complete history of sequence-of-events (SOE) tracking and playback.

SCADA Integrator

Enables quick creation of standardized and reusable templates, efficient system integration, and rapid deployment across the entire organization.

Intelligent Monitoring & Control

State Estimation & Load Allocation

State Estimation processes telemetry data such as power measurements to obtain an estimate of the magnitudes and phase angles of bus voltages including the non-observable portion of the system. Comparison of measured versus estimated values provide an online validation.

Energy Accounting

Detailed energy consumption and cost analysis reports based on user-definable energy tariffs, billings, and electrical power market exchange information.

Cybersecurity

Inscription, signing, authentication, and the use of X.509 certificates are at the core of eSCADA's communication architecture and implementation including user access management and active directory authentication with area-of-responsibility verification.

Native Communication Protocols

Connect and communicate with third-party hardware, DCS, or data collection systems regardless of manufacturer and models using built-in standard network protocols.

- IEC 61850 MMS - client & server
- IEC 61850 GOOSE - subscriber & publisher
- IEC 60870-5 - 101 / 102 / 103 / 104
- IEC 60870-6 / TASE.2 / ICCP - client & server
- Modbus RTU / TCP
- DNP3 - serial & TCP
- OLE for Process Control - OPC DA
- OPC Unified Architecture - OPC UA - client & server
- Common Information Model - CIM
- MultiSpeak
- DLMS
- IEC 62056
- Procome
- Profibus DP



Electrical SCADA Human Machine Interface templates

Customizable web-based interfaces & technology

PSMS™ Power Management System

A powerful solution to predict system behavior, anticipate outcomes, play back events, and recommend alternative actions based on a real-time digital twin.

- ✓ Accurate analysis with actual operating values
- ✓ Improve system planning & design
- ✓ Recognize & correct potential hidden problems
- ✓ Prevent system interruption
- ✓ Determine under-utilization of system resources
- ✓ Identify causes of operational problems
- ✓ Explore alternative actions & 'what if' scenarios
- ✓ Validate system settings

Predictive Simulation

Predictive analysis modules for evaluating actual system response to operator actions, simulation of 'what if' scenarios, and anticipation of outcomes using real-time and archived data.

Event Playback

Conduct root-cause analysis and effect investigations, replay scenarios to determine potential improvements to system operations, and explore alternative actions.

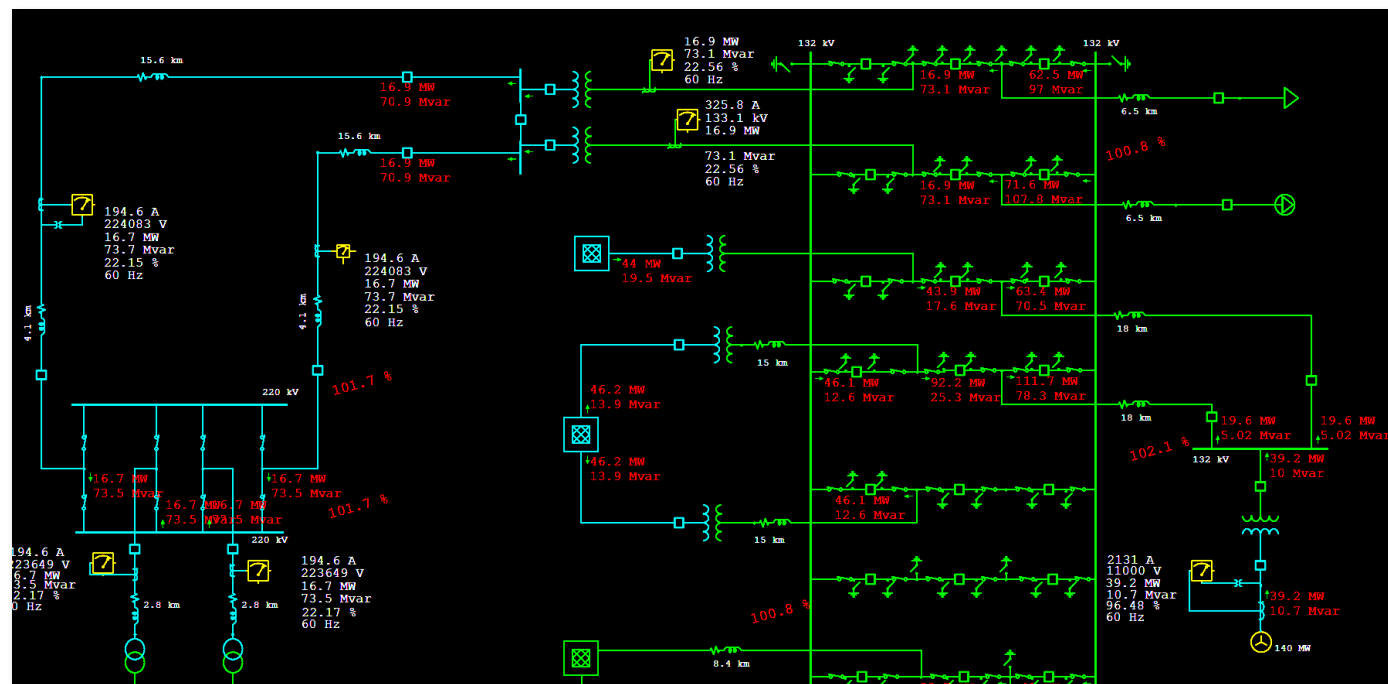

Predict system behavior & prevent inadvertent outages

eOTS™ Operator Training Simulator

Improve and augment operator training through real-world experiential learning and evaluate contingency response to steady-state and dynamic scenarios for applications such as PMS, EMS, GMS, load shedding, and load demand controls.

- ✓ Accelerate operator & engineering training
- ✓ Virtual test of operator & controller actions
- ✓ Simulate & track the sequence-of-operation
- ✓ Ad hoc & pre-defined evaluation scenarios
- ✓ Avoid inadvertent outages caused by human error
- ✓ Improve & develop operator competency
- ✓ Trainer-to-Trainees learning environment
- ✓ Software-in-the-Loop system simulation

Operator Training Simulator

A model-driven power system training simulator that mimics the sequence-of-operation scenarios using real-time data to perform and validate actions such as generator synchronization, load shedding, configuration switching, motor startup, and more.

Preventive Simulation

Preventive analytical modules provide automated alarms and warnings to the operator on possible events such as generator outages, contingencies, and suggest remedial actions.



etap SIL™ – Software-in-the-Loop technologies for dispatcher training & system commissioning

Generation Management System

Monitor, control, and optimize the performance of generation and the connected grid to meet network security, economic, operational, regulatory, and environmental requirements.

Automatic Generation Control - AGC

AGC multi-area supervisory control regulates generation levels in real-time to maintain system frequency and power exchanges with neighboring areas at scheduled values.

Reserve Management

Reserve Management continuously monitors system operating capacity and dynamically calculates the system generation versus load forecast balance to ensure protection against contingency losses.

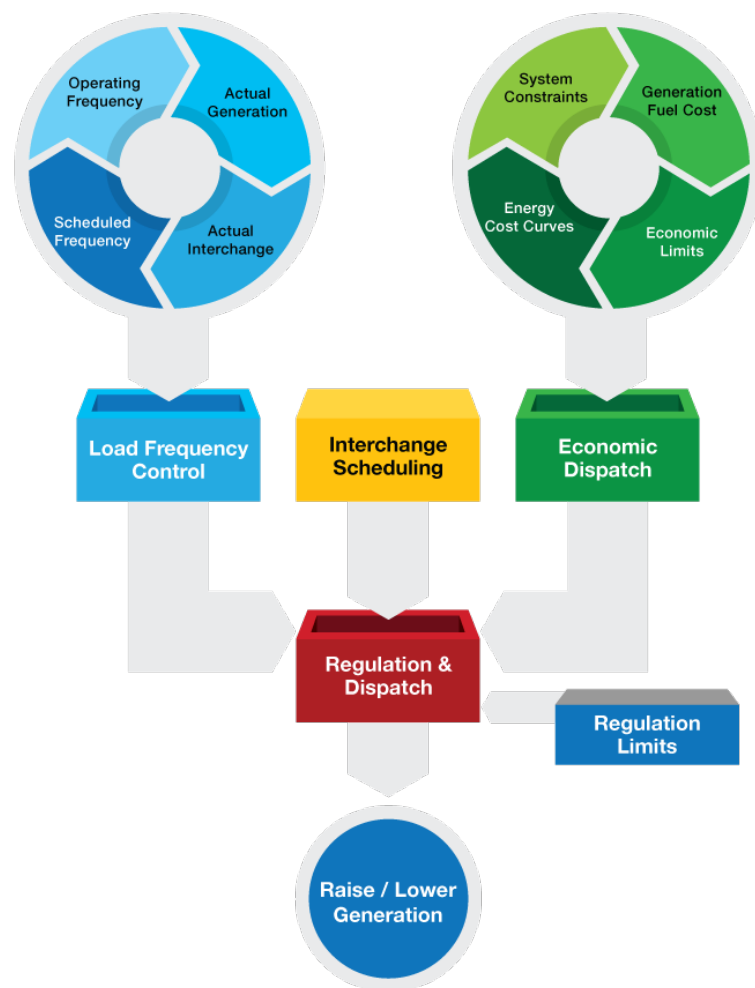

Unit Commitment

Find the least-cost dispatch of available generation resources to meet the electrical load based on constraints such as minimum stable operating levels, ramp rates, unit maintenance periods, scheduled and forced outage information.

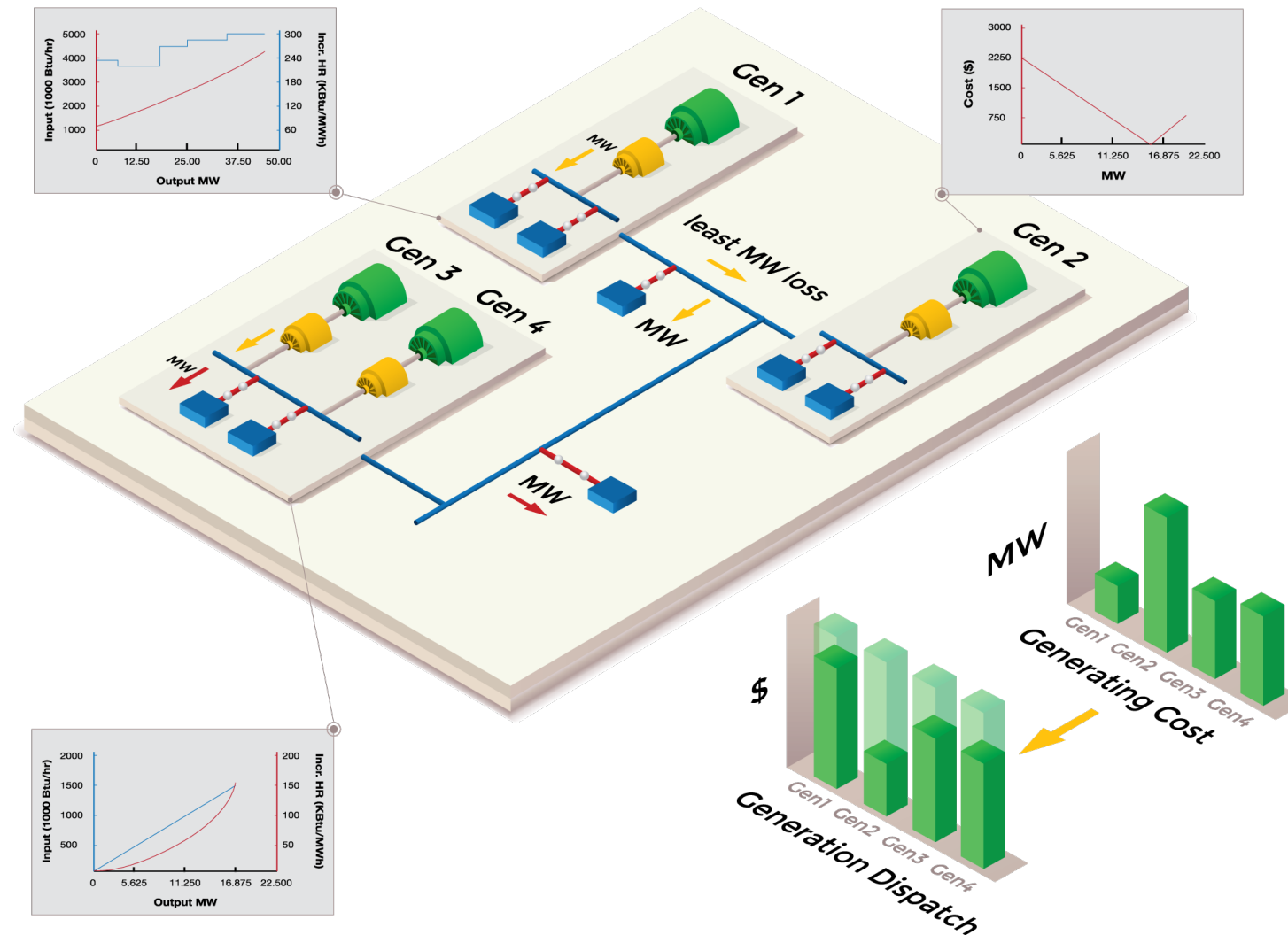

Optimize energy usage to reduce cost

Energy Management System

Energy Management System applications are designed to reduce energy consumption, increase electrical system reliability, improve equipment utilization, predict system performance, and optimize energy usage.

Economic Dispatch

Manage changing generation demand of a power system amongst controllable generator units to achieve optimal area economy, improve power exchange, and maximize security.

Network Security Analysis

Network Security Analysis is ideal for online security analysis, situational awareness support, operations planning, and system engineering studies.

Equipment Outage Scheduling

Schedule outages including generators, transmission lines, transformers, breakers, switches, loads, and compensation devices due to planned service interruptions, unavailability of components, or equipment capacity limitations.

Interchange Scheduling

Schedule energy transfer from one control area to another while considering wheeling, scheduling ancillary services, transaction management, and energy cost analysis and tracking.



Reduce energy consumption

Advanced Distribution Management System

An intelligent and robust collection of GIS-based distribution network applications integrated with mission-critical operational solutions to reliably and securely manage, control, visualize, and optimize small to vast distribution networks.

Intelligent Geospatial Diagram

A user-friendly environment for creating, visualizing and managing geospatial network databases with built-in capability for direct import of electrical data from a GIS database to dynamically create equivalent feeders while maintaining a complete geospatial view of the distribution system.

Distribution Network Applications

DNA is a powerful set of analytical modules that allows the prediction of unbalanced system behavior in response to operator actions and events using real-time and archived data.

Distribution State Estimation

Distribution State Estimation combined with Load Allocation provides intuitive, intelligent, and integrated real-time monitoring of unbalanced distribution systems, including estimation of unobservable subsystems, and calculation of technical and non-technical losses.

Switching Management

Switching Sequence / Work Order Management allows the dispatcher to build, simulate, and verify a complete switching program using a fully graphical user interface to execute approved switching programs in one step, while maintaining compliance with safety and security procedures.

Intelligent Integrated Comprehensive

Feeder Balancing & Loss Minimization

Utilized by planners and operators to minimize system real losses and reduce or eliminate abnormal operating conditions, ETAP ADMS automatically determines the optimal system configuration to achieve multiple user-specified objectives, and suggests locations for new tie-open points based on an advanced switching optimization algorithm.

Volt / Var Optimization & Control

VWOC monitors real-time voltages, watts, and vars from LTCs, regulators, capacitors, voltage sensors, and customer meters to optimize and control the desired power factors and voltage targets.

Load Forecasting

Predict and trend system loading based on algorithms that adaptively correlate multiple input variables, such as weather conditions, as part of an accurate and reliable load forecasting.

Fault Location, Isolation, Service Restoration

FLISR provides operator assistance by identifying probable locations of the fault in the network and recommends the fault isolation and switching actions to clear a fault. Switching plans to restore the supply for unaffected parts of the faulted feeder are presented to the operator for analysis and execution.

Outage Management System - OMS

OMS assists in the restoration of power by predicting failures of isolation devices and providing information on outage extent and number of customers impacted; interfaces to third-party applications for Crew Management, Storm Management, and Estimated Restoration Time.

Planned Outage & Optimization

A set of load curtailment and optimization applications to schedule and execute planned outages to improve system reliability and switching strategies.

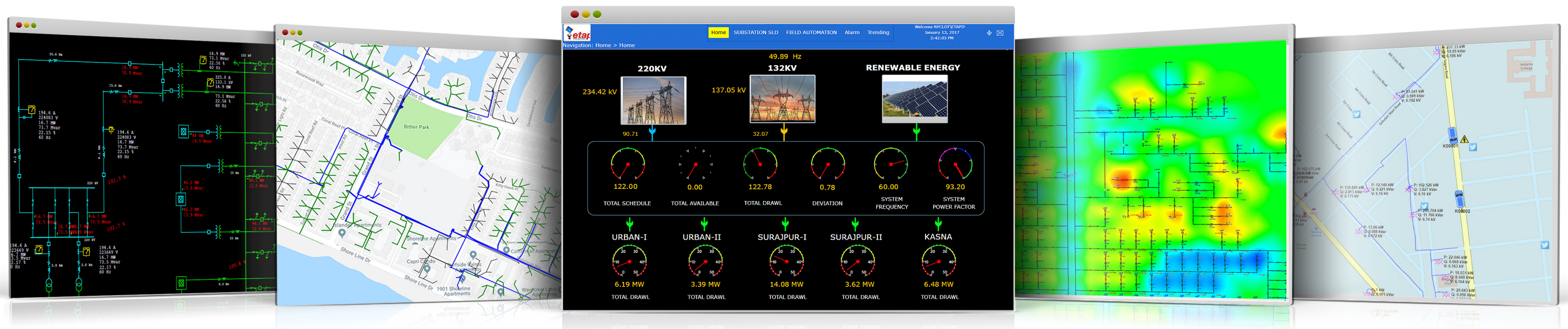

Visualize & analyze distribution systems

Geospatial, schematic & web views

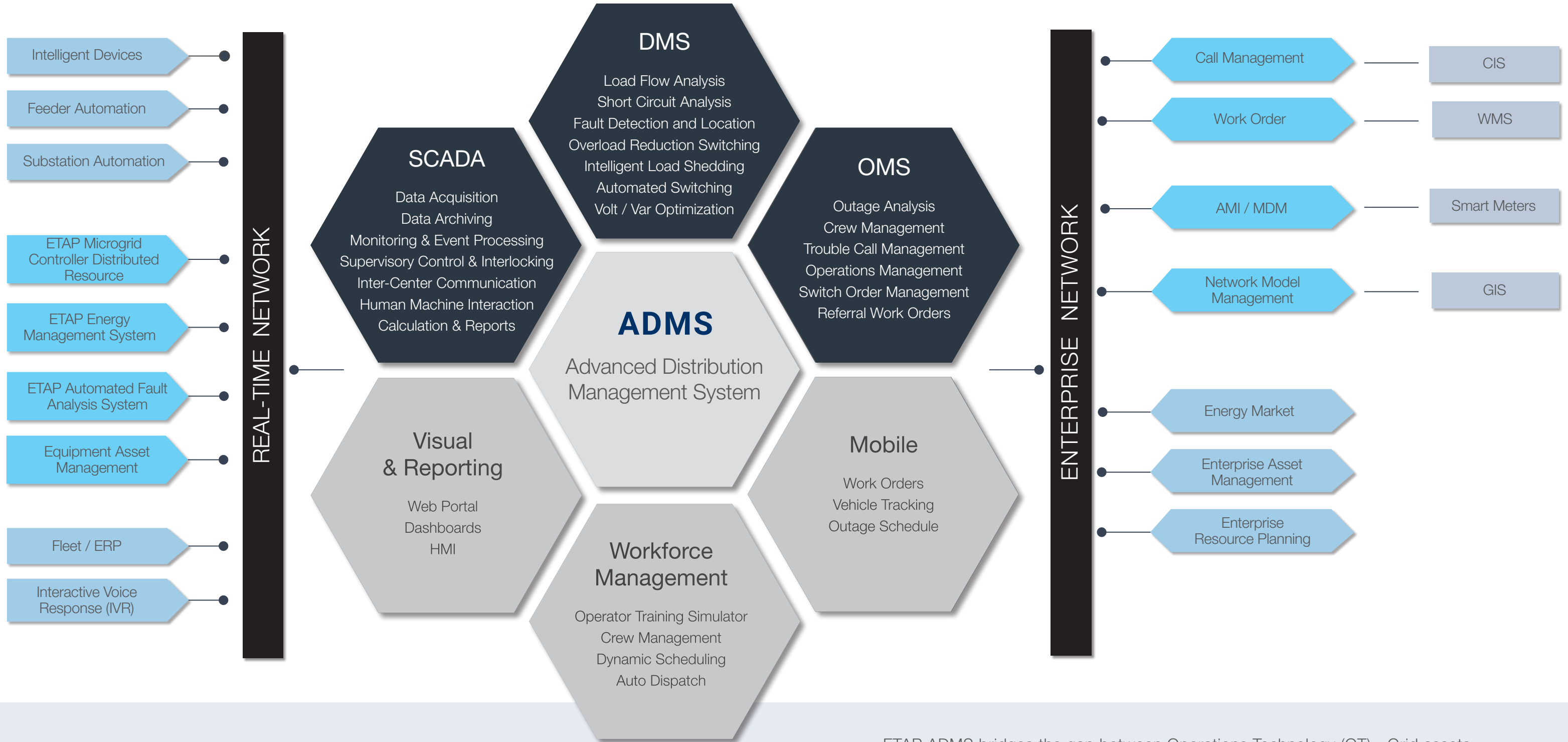

ETAP ADMS bridges the gap between Operations Technology (OT) - Grid assets, infrastructure and applications with Information Technology (IT) - Situational Intelligence for rapid and informed decision making.

iDLS™ Intelligent Distribution Load Shedding

iDLS offers an intelligent model-driven load curtailment system with optimization techniques to shed the minimum required distribution feeder loads based on reliability indices, quality of supply, and availability of distributed generation.

- ✓ Optimized reliability
- ✓ Optimal load preservation
- ✓ Demand side management
- ✓ Load shedding validation
- ✓ Rotating outages
- ✓ Load curtailment logging & auditing
- ✓ Time-of-Use load shifting
- ✓ Service restoration

Optimized Reliability

iDLS utilizes distribution customer's historical information, priority, and restoration time to determine the optimal combination of loads to shed. Load shedding combinations are selected such that customer satisfaction indices and reliability are not significantly impacted. Customer priority, number of previous outage incidents, and restoration times are considered in the optimal selection of feeders or loads to be curtailed.

Load Curtailment Logging & Auditing

All load shedding events, reasons for curtailment, protection alarms, devices and customers affected are logged. Contingency and its effects are available in a chronological table allowing planners and operators to assess and minimize load curtailment requirements to improve overall network reliability, quality of services, and security.

Load ID	Status	Reason	Time
Load1	Shed	Under Voltage	11/19/2019 10:00:00 AM
Load2	Shed	Under Voltage	11/19/2019 10:00:00 AM
Load3	Shed	Under Voltage	11/19/2019 10:00:00 AM
Load4	Shed	Under Voltage	11/19/2019 10:00:00 AM
Load5	Shed	Under Voltage	11/19/2019 10:00:00 AM
Load6	Shed	Under Voltage	11/19/2019 10:00:00 AM
Load7	Shed	Under Voltage	11/19/2019 10:00:00 AM
Load8	Shed	Under Voltage	11/19/2019 10:00:00 AM
Load9	Shed	Under Voltage	11/19/2019 10:00:00 AM
Load10	Shed	Under Voltage	11/19/2019 10:00:00 AM
Load11	Shed	Under Voltage	11/19/2019 10:00:00 AM
Load12	Shed	Under Voltage	11/19/2019 10:00:00 AM
Load13	Shed	Under Voltage	11/19/2019 10:00:00 AM
Load14	Shed	Under Voltage	11/19/2019 10:00:00 AM
Load15	Shed	Under Voltage	11/19/2019 10:00:00 AM
Load16	Shed	Under Voltage	11/19/2019 10:00:00 AM
Load17	Shed	Under Voltage	11/19/2019 10:00:00 AM
Load18	Shed	Under Voltage	11/19/2019 10:00:00 AM
Load19	Shed	Under Voltage	11/19/2019 10:00:00 AM
Load20	Shed	Under Voltage	11/19/2019 10:00:00 AM
Load21	Shed	Under Voltage	11/19/2019 10:00:00 AM
Load22	Shed	Under Voltage	11/19/2019 10:00:00 AM
Load23	Shed	Under Voltage	11/19/2019 10:00:00 AM
Load24	Shed	Under Voltage	11/19/2019 10:00:00 AM
Load25	Shed	Under Voltage	11/19/2019 10:00:00 AM

Rotating Outages

iDLS can be configured to automatically or manually initiate a controlled load curtailment based on load priority blocks, classification, time-of-day, peak demand, and more.

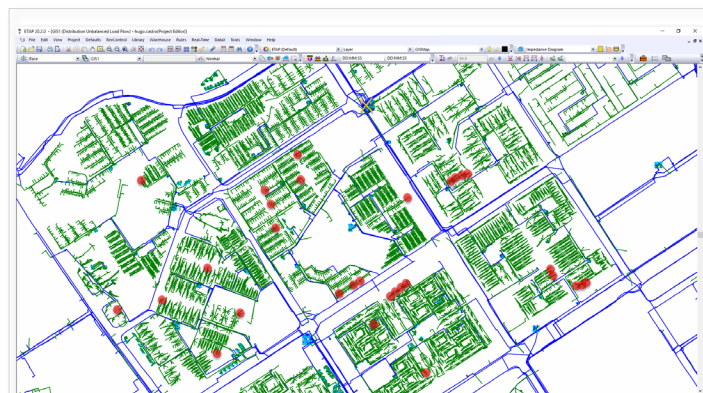

Protection

iDLS evaluates and determines the capacity of all system components and operating constraints in order to protect the network under steady-state and dynamic conditions.

- Transformer overloads
- Under voltage
- Under frequency
- System overload
- Power transfer limits

iLS™ Intelligent Load Shedding

iLS provides optimal, fast load shedding based on actual operating conditions of the system, including type and location of disturbances. iLS dynamically determines the best load shedding priority in a fraction of a second.

- ✓ Eliminate unnecessary load shedding
- ✓ Reduce downtime for critical loads
- ✓ Reduce spinning reserve requirements
- ✓ Reliable load preservation system
- ✓ Fast response to disturbances
- ✓ Integrate with SCADA systems
- ✓ Scalable, interoperable & redundant platform
- ✓ Accurate validation of shedding schemes

Load Preservation

iLS calculates the minimum required power to be shed for each subsystem and accordingly selects the optimal combination of loads that will satisfy these requirements.

Load Restoration

Orderly execute load restoration sequences after a load shedding event, based on operating conditions and rules, while maintaining system stability and reliability.

Load Shedding Validation

Quickly and easily evaluate, verify, and confirm load shedding requirements, decisions, and logic in real-time, using the integration of iLS Controllers and Transient Stability Analysis.

Trigger	Name	Substation	Split Reserve	Cost (\$)	Max Load	Min Load	Min Load	Min Load
UnderVoltage_1	UnderVoltage_1	1	0.000	0.000	0.000	0.000	0.000	0.000
UnderVoltage_2	UnderVoltage_2	1	0.000	0.000	0.000	0.000	0.000	0.000
UnderFrequency_1	UnderFrequency_1	1	0.000	0.000	0.000	0.000	0.000	0.000
UnderFrequency_2	UnderFrequency_2	1	0.000	0.000	0.000	0.000	0.000	0.000
System Overload	System Overload	1	0.000	0.000	0.000	0.000	0.000	0.000
Power Transfer	Power Transfer	1	0.000	0.000	0.000	0.000	0.000	0.000



μGrid™ Microgrid Management System

An integrated model-driven design software and control hardware solution to develop, simulate, optimize, test, and deploy microgrid controllers with inherent capabilities to fine-tune the logic for maximum system resiliency.

Controller Design & Logic Parameterization

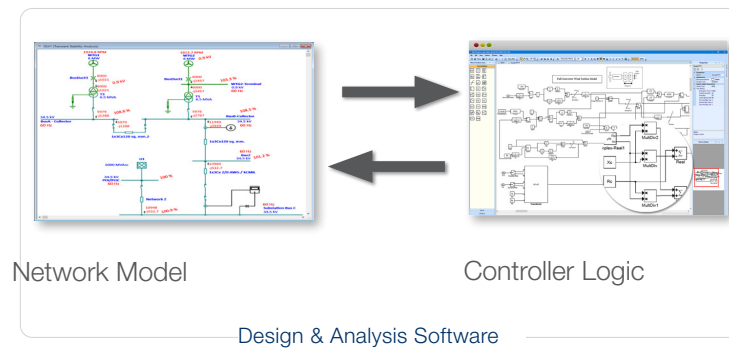

Deploy, Tune & Validate Logic

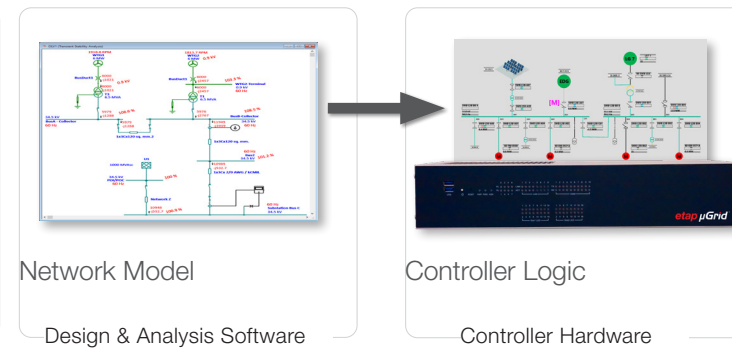

Controller logic is validated using ETAP Software-in-the-Loop (SIL) technology

Edge Control Solution for Microgrids

Model-Driven Microgrid

Deploy and validate hardware controller logic with SIL, steady-state or dynamic analysis. Utilize controller and electrical operations twins to optimize microgrid and hot-swap modified logic to meet performance standards.

Optimize, Tune & Hot-Swap Logic

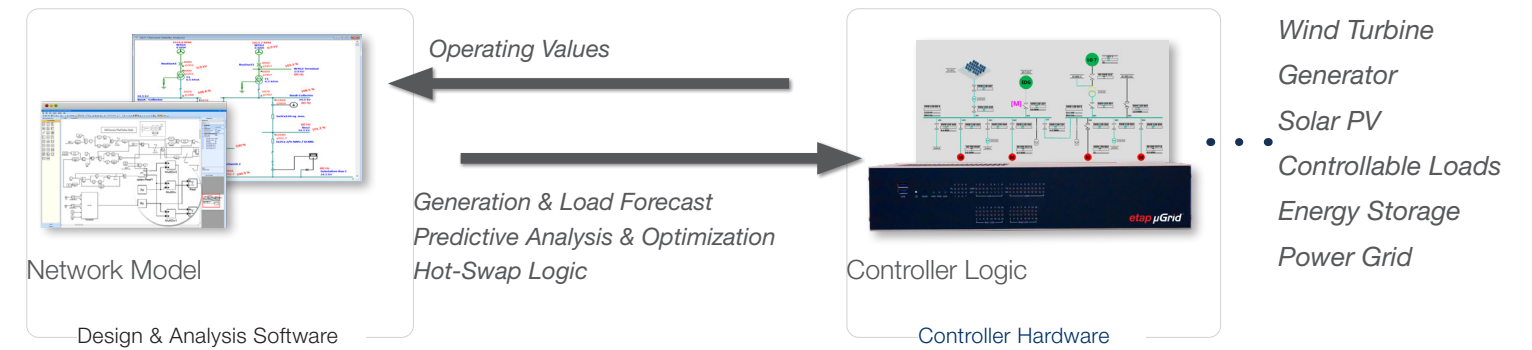

Controller Design Twin to Operations Twin

Generation Optimization

Real-time regulation of generation levels to maintain power exchanges with neighboring areas at scheduled values. Optimization algorithms consider system constraints and multiple objectives such as minimizing energy costs, renewable energy availability, fuel costs, and more.

Generation & Load Forecasting

Intelligent real-time situational awareness and forecast-driven predictive simulations techniques are used to determine reliable and accurate short-term loading and generation, especially from variable energy sources such as wind and solar.

Grid Power Interchange Control

Microgrid Controller regulates real and reactive power interchange between the microgrid and utility service, based on a programmable set point. Importing or exporting power levels are controlled by the system operator or utility.

Energy Storage Management

Microgrid Controller manages control strategies to improve the quality of power production and consumption through renewable energy generation-smoothing by regulating active and reactive power using batteries, Superconducting Magnetic Energy Storage (SMES), STATCOM, and other energy storage devices.

Black Start

Microgrid Controller is capable of manual black start operations to restore the microgrid from a de-energized state. As loads are brought back online, Microgrid Controller automatically adds and increases generation to meet the load demand.

Islanding Management

Proactive generation dispatch and switching control to regulate voltage and frequency for system preservation during and after an islanded condition.

Demand Side Management

Evaluate energy-reducing strategies to implement on-peak to off-peak load shifting and rate schedule changes to optimize energy usage and reduce cost.

Master Controller

Microgrid Master Controller integrates photovoltaic systems, generator sets, and energy storage systems to maximize usage of renewable energy sources and system reliability.

The master controller is a secure Linux-based hardware that may be configured remotely, including monitoring and parameterization.

Remote eSCADA Interface

Microgrid controller integrates with ETAP eSCADA to monitor, analyze, and provide KPIs for the complete microgrid.

- Renewable smoothing
- Generator transient assist
- Grid firming / grid stabilization
- Facility backup
- Grid forming
- Spinning reserve
- Time shifting of renewable energy
- Peak shaving



Grid Compliance System

Maximize yields and meet TSO stability & power quality requirements at POI with ETAP Grid Compliance solution, including model-driven eSCADA platform, ePPC™ Power Plant Controller, and eTESLA™ Dynamic System Monitoring Recorder.

- ✓ Ensure resiliency & reliability of power supply
- ✓ Conform to grid requirements
- ✓ Reduce risk throughout planning and operations
- ✓ Full dynamic control for enhanced stability
- ✓ Power conditioning & improved power quality
- ✓ Enhance reliability by utilizing dynamic models
- ✓ Meet investor expectations of energy yield
- ✓ Accurate forecast of yield & transfer capability
- ✓ Operation, maintenance & compliance auditing
- ✓ Greater transparency & investment security

Intelligent Design & Engineering

Perform automated steady-state and transient studies, design and simulate power plant controller logic to simulate optimal grid performance under all possible situations.

Performance Testing & Validation

Test and validate power plant controller logic with ETAP SIL technology to ensure smooth commissioning and approval procedure when connecting to the grid. Reduce downtime via direct deployment or hot-swap of logic to Power Plant Controller.

Design, Monitoring & Reporting

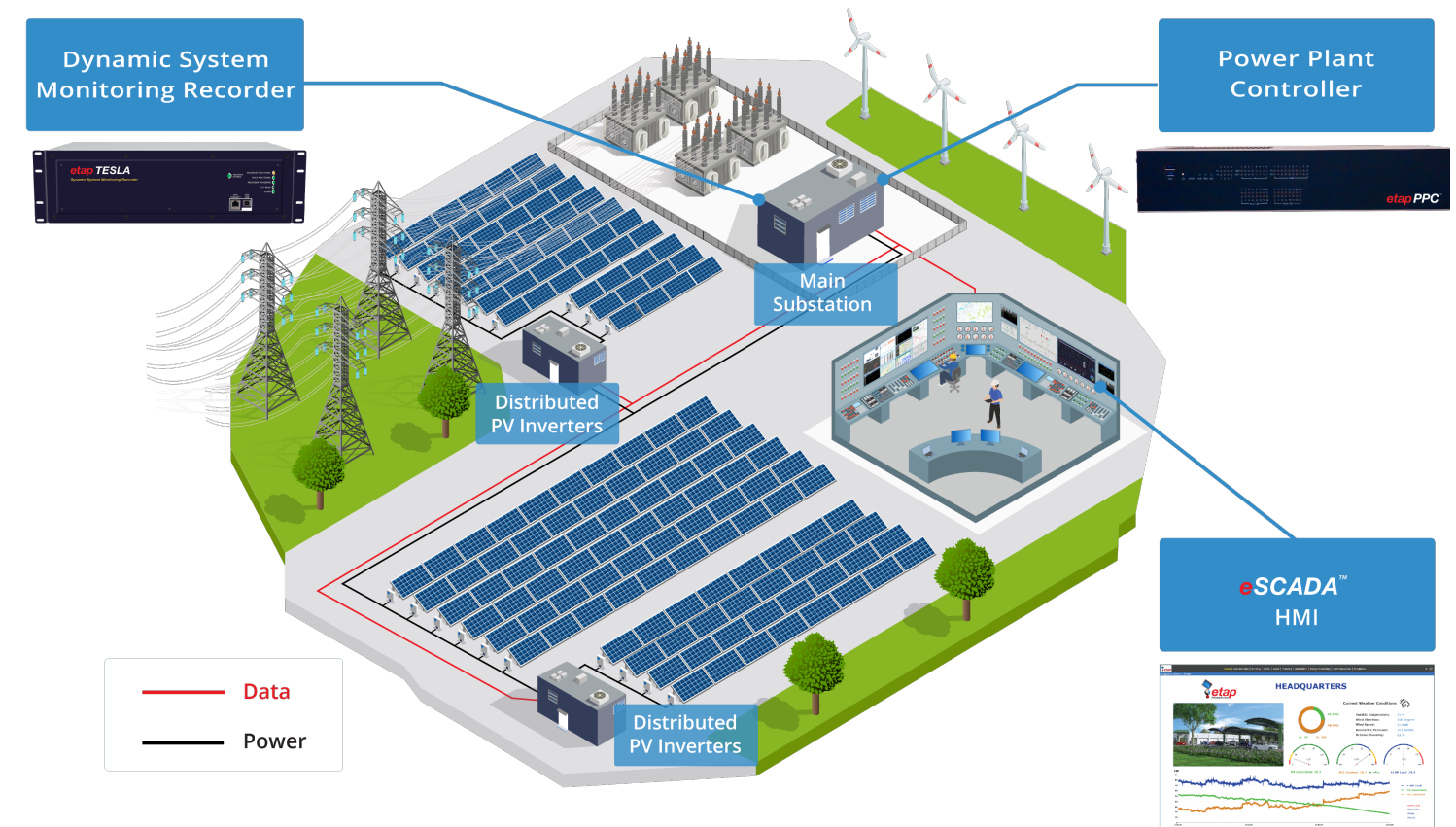

ePPC™ Power Plant Controller

Intelligent and secure controller hardware ensures compliance with local grid code and standards. ePPC leverages a model-driven electrical digital twin for visualization, predictive calculations, optimization and management of renewable power plants.

Integrated Plant Controller & SCADA

Monitor and gain insight into asset health and perform preventive maintenance based on present and anticipated conditions by combining PPC and SCADA with dedicated HMIs and predictive analysis applications.

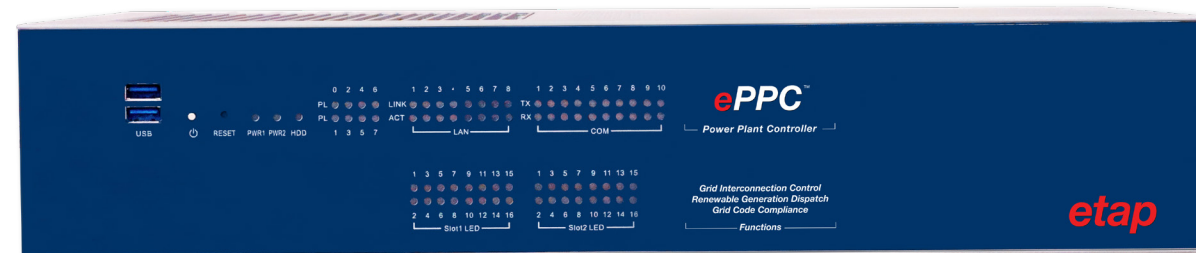

eTESLA™ Dynamic System Monitoring Recorder

Continuous monitoring of steady-state and dynamic plant response to tune the electrical model, identify generator / AVR / governor and control parameters, and confirm PPC response under actual operating conditions.

Grid Compliance Monitoring & Reporting

TESLA hardware and software solution performs assessment and continuous audit of actual operation versus expected response. System operating condition is compared with established grid code rules for compliance reporting and evaluation.

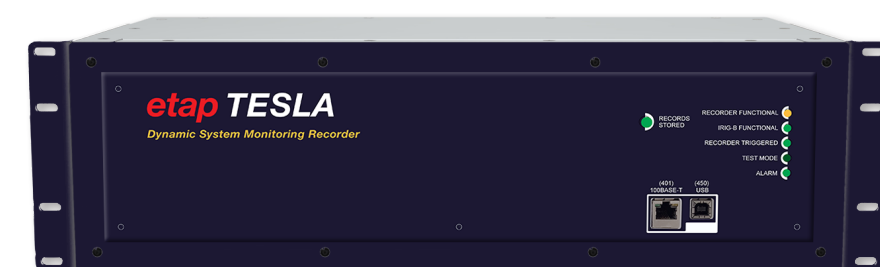

nanoGrid Energy Management System

etap nanoGrid EMS (nEMS) is a multi-site remote management solution, interfacing with IoT devices to monitor, automate, control, optimize, determine health indices, and generate optimal maintenance schedules while minimizing OPEX.

- ✓ Remote management of decentralized nanogrids
- ✓ Reduce power consumption with automated, intelligent controls
- ✓ Reduce maintenance & replacement service visits
- ✓ Extend equipment lifetime by maintaining stable environmental conditions
- ✓ Improve reliability & operation of backup power
- ✓ Minimize transportation & onsite fuel losses
- ✓ Consolidate data from multiple sites via vendor agnostic platform
- ✓ Immediate return-on-investment through easy configuration & quick deployment

Automatic Islanding Detection & Nanogrid Control

Effective operation and control are determined based on the priority of energy generation resources. Utilizing renewable energy resources first, followed by energy storage, ensuring effective energy management for a stable and reliable power system at the lowest cost possible.

Equipment Condition Monitoring & Health Estimation

nEMS is designed for quick time-to-market for preventive maintenance initiatives. Data is collected across multiple sites from similar devices to learn equipment behavior patterns and identify performance deterioration. nEMS applies machine learning and big data mining algorithms for predicting equipment health and schedule maintenance under degraded conditions.

IoT Aggregation & Integration Platform

The platform utilizes distributed architecture for open scalability by connecting multitudes of data acquisition devices, storage, processing, advanced analytics tools, visualization interfaces, and enterprise-level applications integrated in a unified multi-site solution.

Energy Accounting

Energy Accounting software provides energy usage analysis and cost allocation for individual generation units, areas, and the entire system. nEMS can track and create energy billing reports based on user-definable energy cost functions and energy tariffs.

nEMS Multi-Site Remote Management

Remote Multi-Site Monitoring & Data Analytics

Multiple sites are connected via a cloud-friendly, web-based, secure, platform with interoperability through standard protocols and leveraging scalable NoSQL databases.

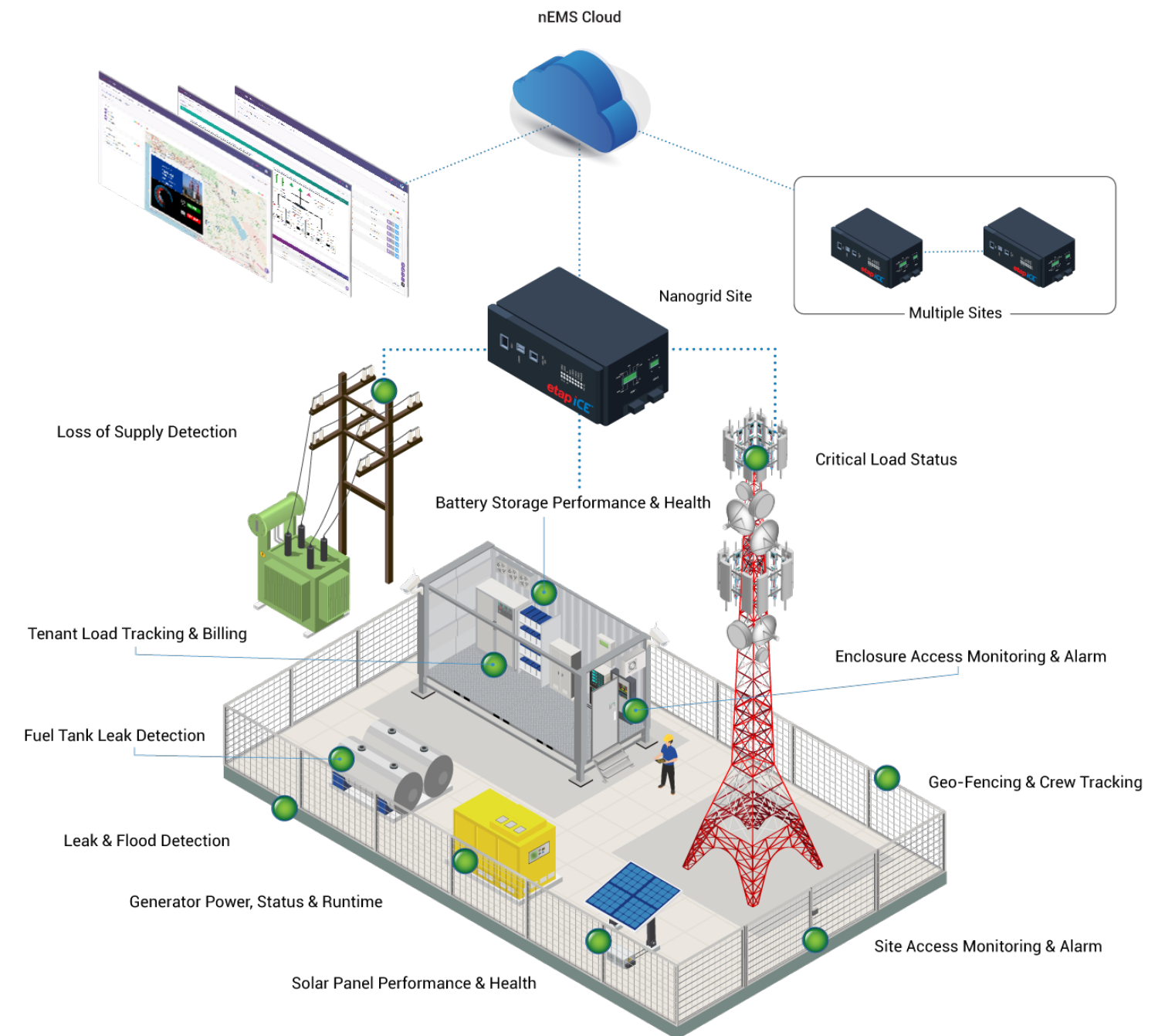

nEMS with etap iCE for Monitoring, Alarming & Automated Control

iSUB™ Substation Automation System

iSub intelligent Substation Automation System (SAS) provides protection, control, automation, monitoring, and communication applications as part of a comprehensive substation solution.

- ✓ Switching management system
- ✓ Flexible automation & built-in controls
- ✓ Load management system
- ✓ Sequence-of-event recorder
- ✓ Integration of protection systems
- ✓ Predictive & preventive maintenance

Switching Management

Switching Management allows the dispatcher to build, simulate, and verify a complete switching program using a fully graphical user interface. The approved switching programs can be executed in one step, while maintaining compliance with safety and security procedures.

The screenshot displays the iSUB software interface. On the left, a schematic diagram shows a substation layout with components labeled 'Line3', '795-54', '#1 Open', '#6 Ground', '#2 Open', and 'Open'. The main area features a 'Switching Orders' table with columns for SW O ID, Req Dept, Type of Request, Schedule Start, Duration, Status, Classification, Division, Voltage Level, SO Type, and Attachment. Below this is an 'Activity Logs' table. On the right, there are panels for 'Info', 'Review', 'SSM', 'Approve', 'Switch Plan Execution', and 'Post', along with a 'Sequence' configuration area and a 'Device Logic' table.

Substation Automation

Substation Automation utilizes intelligent analysis processes to dynamically manage, monitored data for substation levels and central system evaluation.

- Automatic voltage control
- Synchronism
- Tap position monitoring
- Load & bus transfer
- Load curtailment
- Capacitor control algorithm
- Substation maintenance mode
- Fault detection

Load Management

Load Management evaluates and implements energy-reducing strategies such as peak-load shifting, load-start inhibition, and shedding of non-critical loads to reduce energy cost.

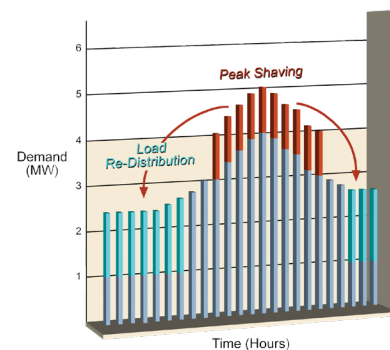

iCE™ Intelligent Control Enterprise

etap iCE™ Intelligent Control Enterprise hardware platform includes programmable Controllers and Remote Terminal Units integrated with ETAP applications for optimal performance, fast response, and cybersecurity.

- ✓ Modular & flexible design
- ✓ Cost effective & affordable
- ✓ Standardized with ETAP Real-Time applications
- ✓ Compliant with international standards
- ✓ High performance & availability
- ✓ Built-in redundancy

Data Acquisition Devices

- Remote Terminal Units for HV / MV facilities
- Substation data acquisition
- Communication gateway
- Grid compliance monitoring & recording

Intelligent Controllers

- Load shedding Controller
- Microgrid Controller
- Power Plant Controller
- Substation Automation Controller

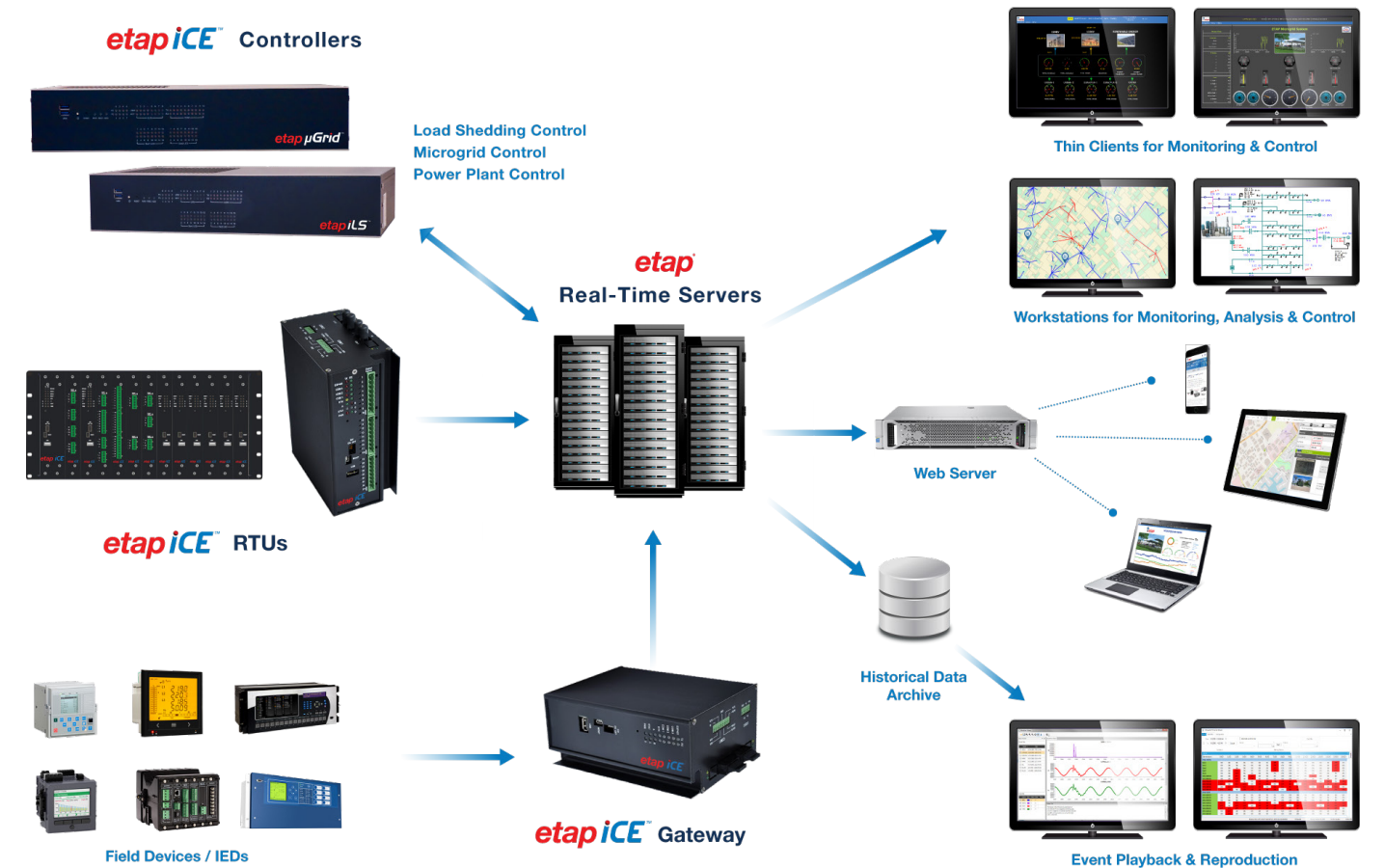

Support, Trainings & Conferences

ETAP is dedicated to overall customer satisfaction through unmatched technical support, software workshops, power system engineering trainings, and informative technical events across the globe.

Technical Support & HelpDesk

Highly trained and experienced support engineers are available to ETAP customers to answer any question about ETAP software. The ETAP online HelpDesk is available 24/7 to submit support tickets, download software, or browse through thousands of FAQs related to ETAP software.

Trainings, Workshops & Webinars

A wide range of hands-on ETAP workshops, on-site trainings, webinars, and customized classes are offered globally. Training courses are conducted by certified ETAP instructors with an extensive knowledge of the software and its applications. Continuing Education Units (CEU) are available for selected events.



Conferences & User Summits

ETAP frequently hosts global and regional conferences, technical summits and user group meetings. These informative and technical events cover ETAP presentations and user case studies featuring a broad range of electrical power systems applications and the latest ETAP solutions.

These events are established in various locations worldwide and provide the opportunity for customers to participate, share experiences, and network with industry peers.



Engineering Services & Quality Assurance

ETAP offers expert solutions services including engineering consulting, geospatial database mapping, data exchange & synchronization, integration & commissioning of ETAP Real-Time system, and more.

Analytical Engineering Services

Engineering services specialize in power system analysis, conceptual design, preliminary engineering, network planning, dynamic modeling & field-measured parameter tuning, dedicated research & development projects, and optimization studies to solve demanding and complex engineering problems.

ETAP Real-Time Integration

System integration services provide turnkey solutions to interface data acquisition systems and metering equipment to ETAP Real-Time Solution. The power and versatility of ETAP combined with the vast knowledge and experience of our global field services team guarantees a successful implementation of your system monitoring and automation project.

GIS Integration

Geo-linking services provide database mapping and synchronization of electrical equipment information between Geographic Information Systems into ETAP. The objective is to provide the necessary tools to integrate and manipulate GIS maps while working in ETAP.

Data Exchange & Conversion

ETAP DataX services can be employed for converting data files and the development of new data conversion programs / exchange tools based on customers' specific needs. ETAP engineering team and database specialists can perform database conversions, synchronization, and validation between original data files and ETAP's project database.

Quality Assurance Commitment

ETAP is Verified and Validated (V&V) against field results, real system measurements, established programs, and hand calculations to ensure its technical accuracy.

The compliance to Quality Assurance standards ensures ETAP's commitment to continuous improvement of its quality solutions covering all activities related to software development, testing, production, engineering services, and technical support.

- Mature QA program based on international standards
- V&V system performance & engineering libraries
- QA accredited technical support
- ISO certified system engineering & integration services

 10002889 UL REGISTERED FIRM DQS Inc. ETAP	ISO 9001:2015 ANAB ACCREDITED MANAGEMENT SYSTEMS CERTIFICATION BODY
U.S. Code of Federal Regulation:	ISO 9001
10 CFR Part 50, Appendix B	ASME NQA-1
10 CFR Part 21	IEEE 730.1
10 CFR Part 50.55	CAN / CSA-Q 396.1.2
ANSI / ASME N45.2	ANSI N45.2.2

Supporting a diverse range of business sectors

across the global energy landscape



etap.com

© 2020 ETAP / Operation Technology, Inc. All rights reserved. Certain names and/or logos used in this document may constitute trademarks, service marks, or trade names of Operation Technology, Inc. Other brand and product names are trademarks of their respective holders.

ETAP | 17 Goodyear | Irvine, CA 92618 | T 800.477.ETAP | T +1.949.900.1000 | info@etap.com

B52-POV-FEB2024