

IO-Link[®] Solutions



1. Allows seamless and simple device replacement
2. Standardizes and reduces wiring
3. Can replace analog
4. Connects to non-IO-Link devices
5. Increases data availability
6. Allows device configurations to be read and changed remotely
7. Permits advanced diagnostics
8. Enables IIoT connectivity



Learn More About the Advantages of IO-Link



DXMR110-8K System Diagram

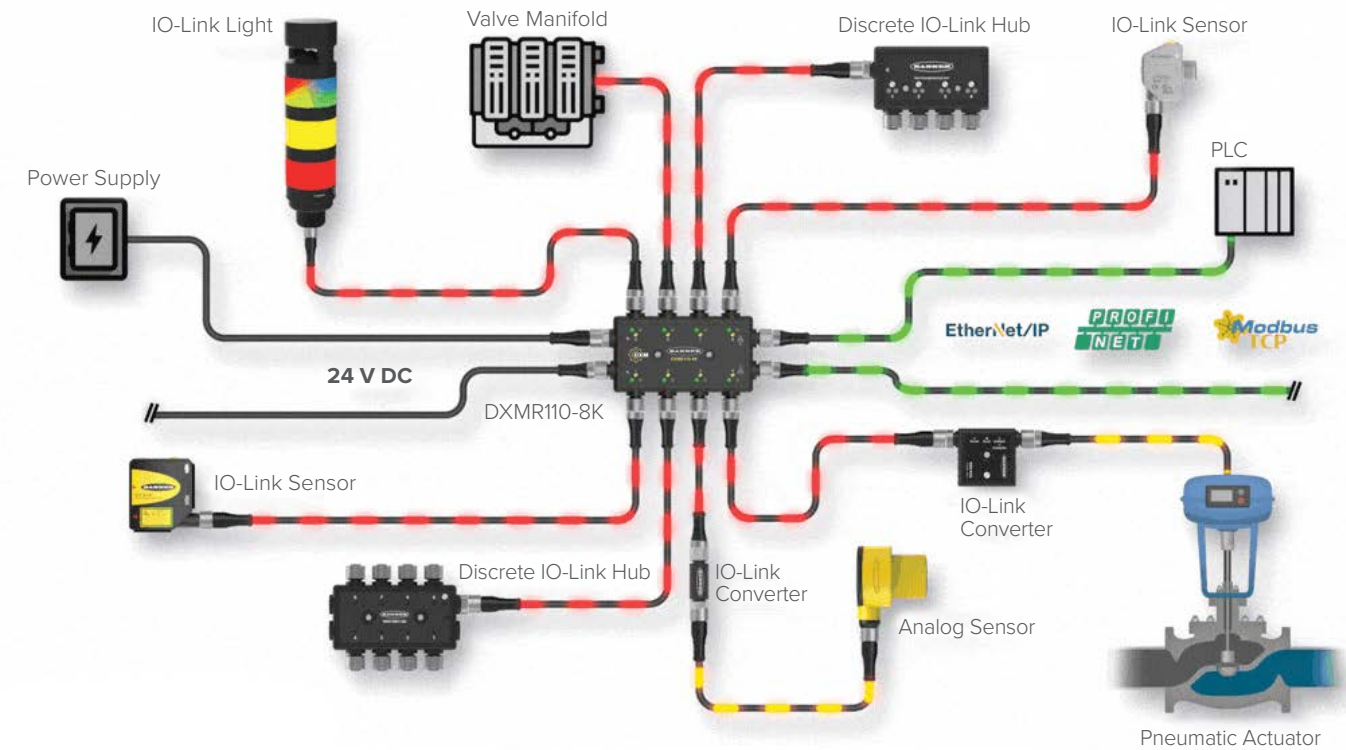

- Banner offers a wide selection of IO-Link sensors, lights, converters, hubs, and IO-Link masters
- Converters offer scalability for the future
- Online configuration software and AOs make IO-Link device connection easier
- Rugged IO-Link masters are the most compact in the industry
- Advanced programmability allows engineers to solve unique application challenges

Introduction to IO-Link

In recent years, IO-Link systems have become widespread within industrial automation. IO-Link is an open-standard serial communication protocol that allows for the bi-directional exchange of data from sensors and devices that are connected to a master. The IO-Link master can transmit this data over various networks, fieldbuses, or backplane buses, making the data accessible for immediate action or long-term analysis via an industrial information system, like a PLC, HMI, and others. Banner IO-Link products reduce wiring, increase data availability, enable remote configuration and monitoring, simplify device replacement, and provide extended diagnostics. Banner Engineering offers a variety of IO-Link products for industrial applications including sensors, lighting products, converters, hubs, and IO-Link masters.

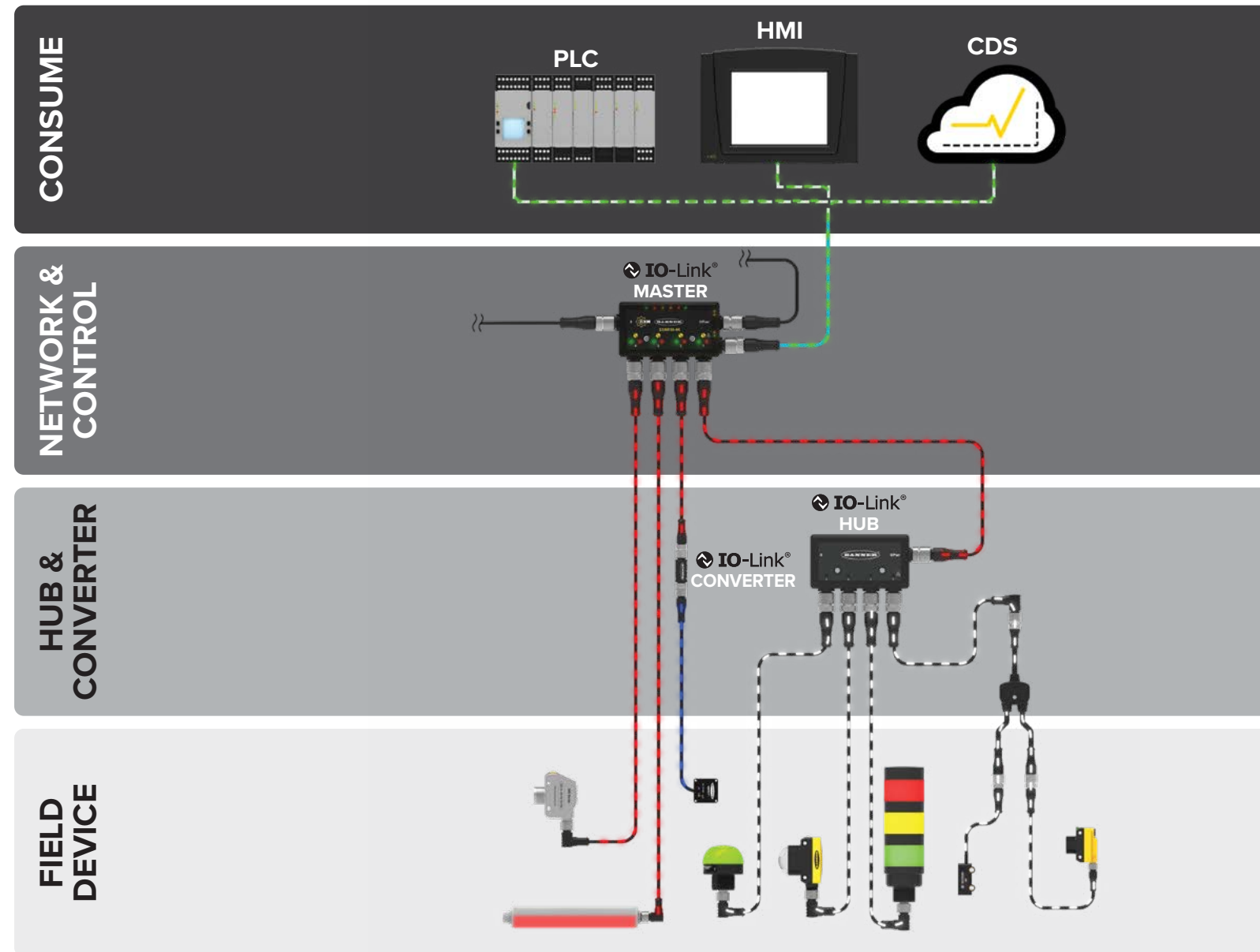

Capture Actionable Data

Banner is a leader in IO-Link solutions for industrial applications. We offer sensing and lighting products specifically designed to excel in IO-Link applications. Our IO-Link photoelectric sensors provide precise object detection for enhanced automation and control. Our fiber optic amplifiers offer seamless data exchange with exceptional accuracy. Our laser measurement sensors enable precise distance and position measurements in IO-Link applications for efficient and accurate process monitoring. With robust detection capabilities, our radar sensors ensure reliable, real-time object tracking in IO-Link networks, even in challenging environments. To enhance performance of IO-Link systems, Banner lighting products offer brilliant illumination, improving visibility and enabling better decision-making. Versatile designs allow for easy mounting and integration, simplifying installation and reducing downtime. And all Banner products are built to withstand harsh industrial environments, making them ideal for IO-Link applications.



Optimize Robotic End-of-Arm Tooling Applications

- Banner's compact and light weight IO-Link masters can help optimize machine designs and performance in robotic end-of-arm tooling applications
- Unique form factor with M12 ports on the sides allowing better cable routing and less cable bend radius issues

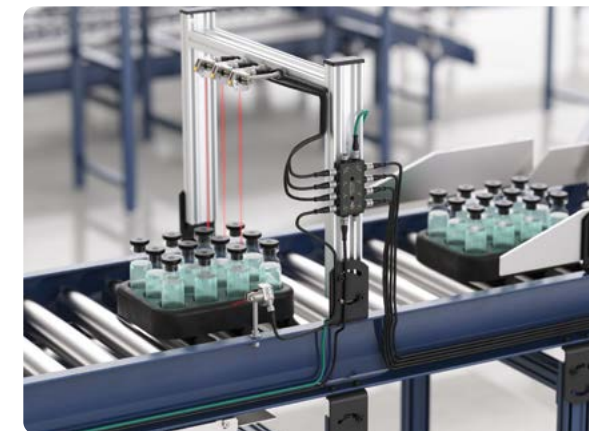
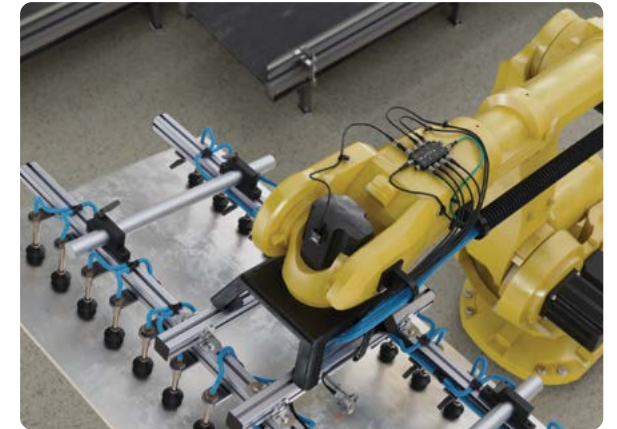

Object Verification on Bottling Line

- Banner's IO-Link Q4X laser distance sensor offers dual discrete outputs. IO-Link allows for remote device configuration, sensor backup and easier diagnostics.
- With the capability to detect height changes as small as 0.5 mm and distances up to 300 mm, the Q4X can solve distance-based applications regardless of target surface reflectivity, including black foam on black plastic, black rubber in front of metal, multicolor packaging and targets of all colors

Reduce Machine Costs, Simplify System Designs, and Reduce Installation Time

- Combinations of Banner IO-Link masters and IO-Link hubs allow the processing of up to 128 I/O signals
- Standardizing on IO-Link hubs enables users to reduce wiring to the PLC and standardize on M12 cables, which are cost effective and easy to install



Learn more at snapsignal.bannerengineering.com



QS18 All-Purpose Compact Sensors

- Includes rugged, sealed housing with protected circuitry
- Easily fits (or retrofits) almost any mounting situation
- Has less than 1 millisecond output response for excellent sensing repeatability
- Capable of ranges up to 20 m
- Offers mechanical and electronic adjustable field background suppression

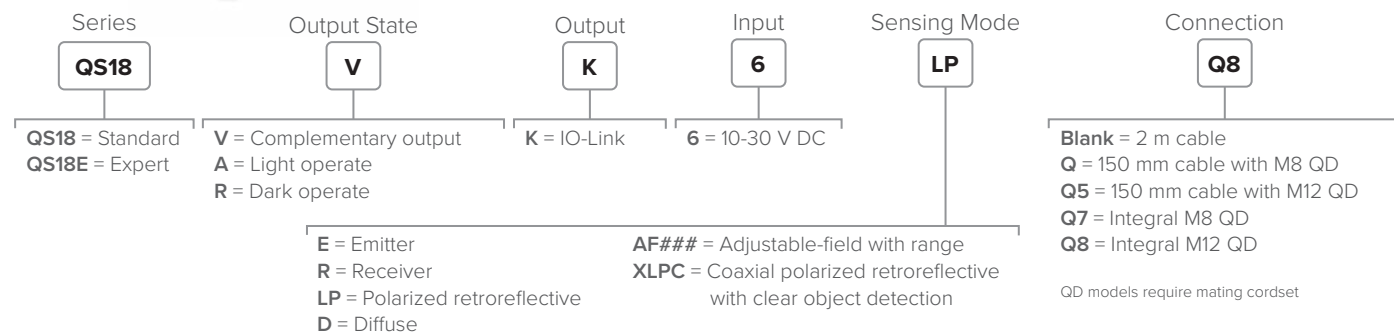

Q20 Compact Sealed Sensors

- Compact, rugged, sealed, overmolded plastic housing
- Standard 3 mm threaded mounting holes on 25.4 mm (1 in.) spacing

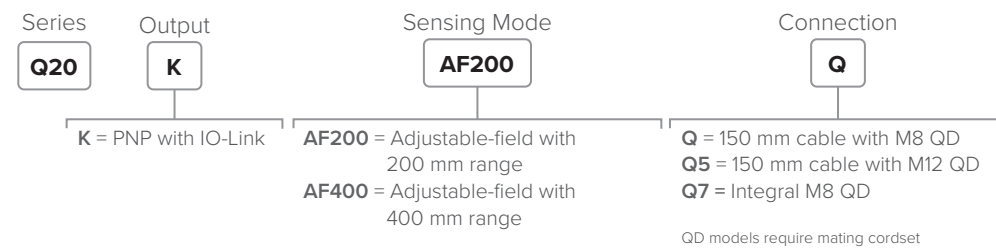

Q2X Laser Measurement Sensors

- Measure farther with the industry's longest sensing range for a sensor in a compact housing
- Sense the most challenging targets like dark or shiny poly bags with a powerful infrared laser with best-in-class excess gain
- Employ sensors in many applications by consolidating to one sensor model with an array of sensing modes, including background suppression, window mode, and dual model

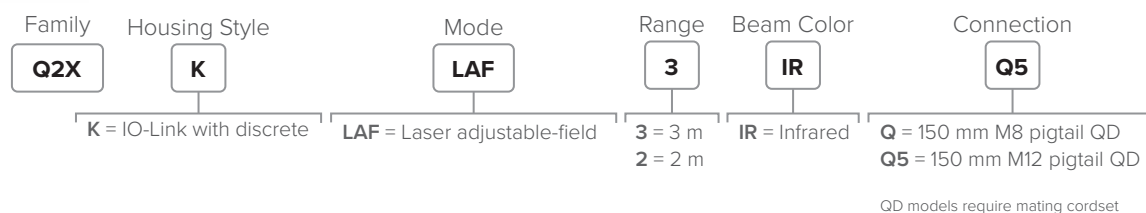

Q76E Wide Beam Retroreflective Sensors

- Visible red beam for simple alignment and bright LEDs for visual indication
- Up to four meter range for mounting flexibility
- Two sensitivity levels for detection of challenging targets such as shrink wrapped pallets, small objects and film or perforated packaging
- Easy set-up, adjustment and LO/DO selectable via single push button

Range	Input	Output	Cable	Models
0.4 mm to 4.0 m	10 to 30 V DC	1 PNP/NPN light operate with IO-Link; 1 PNP dark operate	200 mm PUR cable with a 4-pin M12 male quick disconnect	Q76E-KP-ZLVC-Q5



DF-G3 Long-Range Fiber Optic Amplifiers

- Easy-to-use DIN-rail-mountable fiber optic sensor
- Compact housing with dual digital displays and bright output LEDs for easy programming and status monitoring
- Available in high power models, ultra-fast models, and specialty models
- Compatible with a wide variety of fiber optic cables to fit into any application

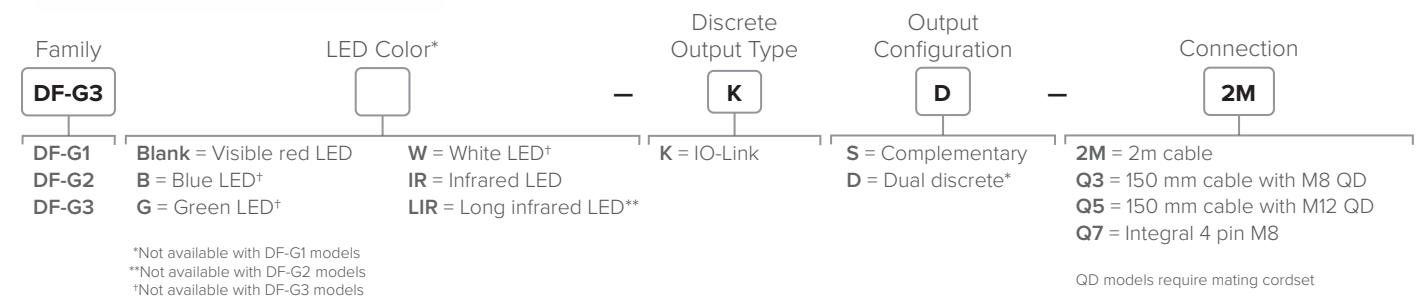

LTF Long-Range Laser Measurement Sensors

- Best in class combination of range, repeatability and accuracy enables reliable target detection and precise distance measurement
- Durable IP67 metal housing with 100G shock rating
- High ambient light immunity and stable performance across temperatures provides reliable performance in challenging environments





T30R Radar Sensors

- Reliable detection of high-dielectric targets (like metal or large amounts of water) and lower-dielectric materials (such as wood, rock, or organic material)
- Compact, IP67-rated housing for use in challenging environments (T30RW model features IP69K-rated housing)
- Crosstalk immunity, allowing for multiple sensors to be mounted in close proximity

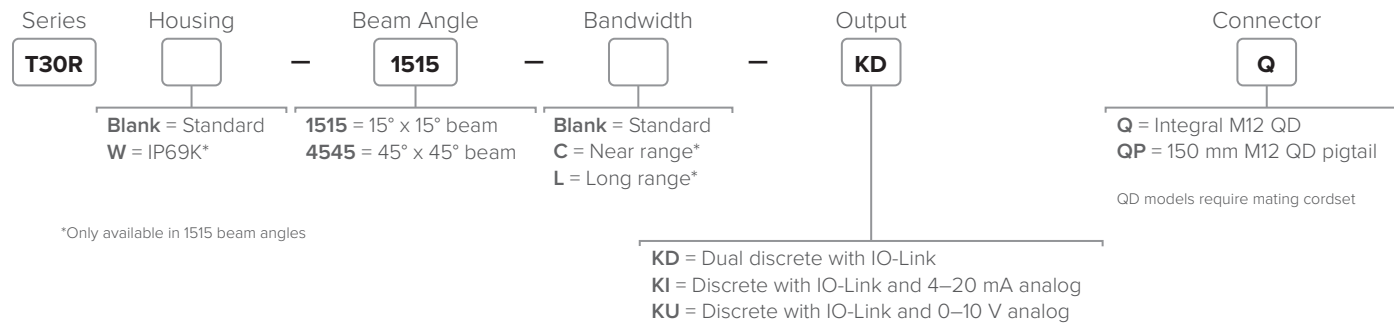

Q5X Laser Measurement Sensor

- Best price with performance mid-range sensing solution
- Highest excess gain for detecting the darkest targets at extreme angles
- Dual mode for contrast and clear object detection without a reflector
- Jam detection model alerts operators to production line jams, reducing or preventing downtime

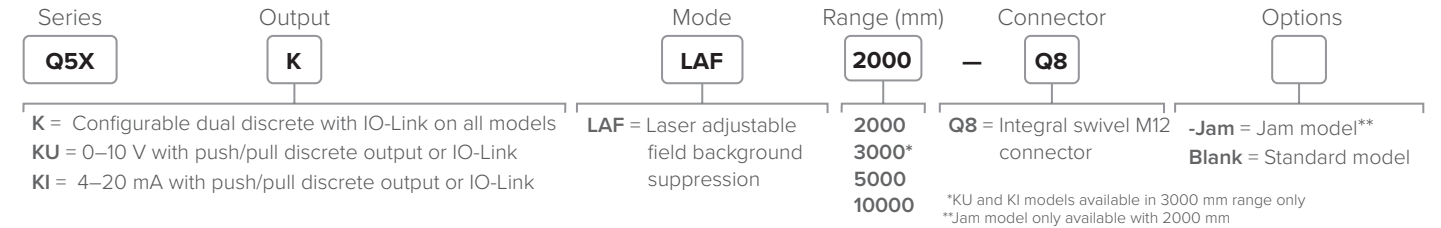

LE Precision Mid-Range Laser Measurement Sensors

- Highest-precision sensor for mid-range applications from 100 mm to 1 m
- Low-temperature effect for measurement stability in any environment
- Class 1 and Class 2 laser options

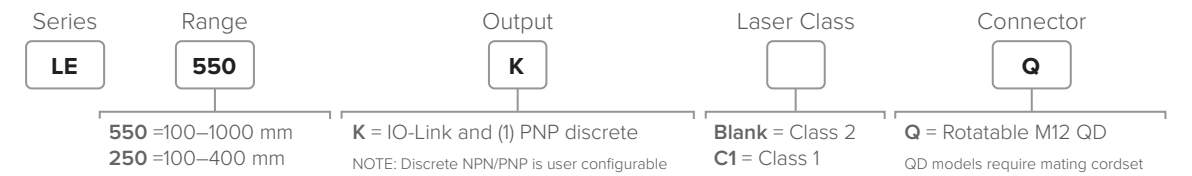

Q4X Rugged Laser Measurement Sensors

- Best price with performance short-range sensing solution
- Most compact, rugged IP69, Ecolab-certified, stainless-steel housing
- Dual mode for contrast and clear object detection without a reflector
- Flush mount or barrel mount housing options for versatility in mounting

Threaded-Barrel Q4XT



Flush-Mount Q4XF

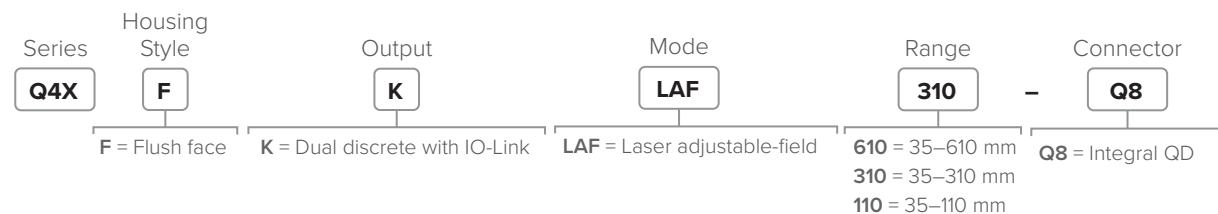

LM Compact Laser Measurement Sensors

- Short-range, high precision, even on shiny metals
- Smallest spot size for more measurements and fewer color-transition errors
- High excess gain for detecting the darkest targets
- Least affected by temperature changes, for measurement stability in any environment
- Small stainless-steel housing for longevity and durability

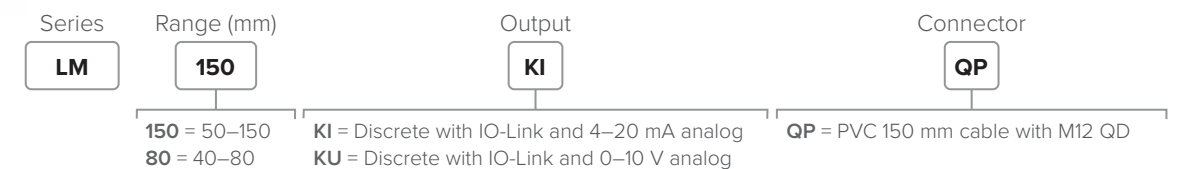



QCM50 High-Performance Color Sensors

- Reliable color detection across the entire range of the sensor
- Up to twelve colors can be detected with one sensor, reducing inventory costs and enabling faster changeover
- Anti-glare model is available to reliably detect reflective targets
- Intuitive configuration with integrated digital display and on-board buttons

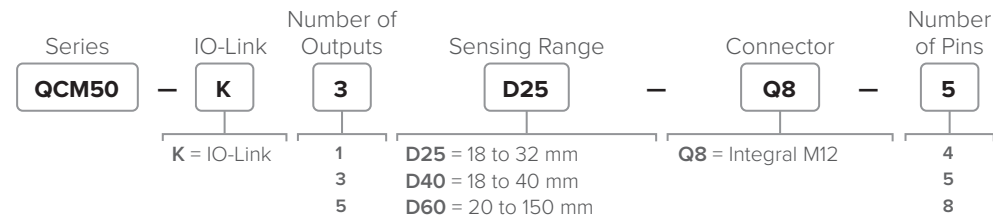

S15S Temperature and Humidity Sensor

- Temperature, humidity, and dewpoint monitoring with configurable discrete output thresholds or windows for high and low thresholds
- Ships with aluminum grill filter cap
- Optional stainless steel 10 µm sintered filter available separately
- Smart Sensor profiles available for process data modes in Fahrenheit, celsius, and floating point

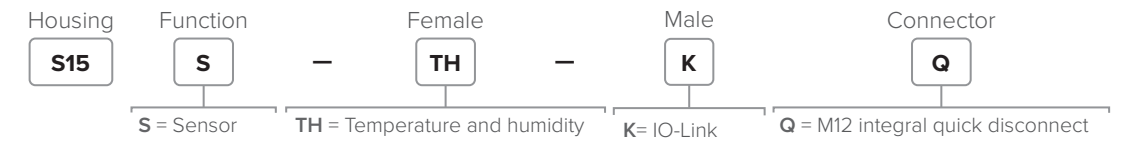

EZ-ARRAY Measuring Light Curtains

- Applications include edge and center-guiding, loop tension control, hole sizing, parts counting and on-the-fly product sizing and profiling
- Closely spaced infrared beams provide 5 mm resolution or 2.5 mm single edge resolution
- Controller functionality is built into the receiver, so basic setup requires no controller, software, or PC
- Configuration options include 14 measurement modes, three scanning methods, two analog and two discrete outputs, and a serial output

Array Length	Total Beams	Receiver Discrete Output	Receiver Analog Output	Emitter Models	Receiver Models
150 mm	30	PNP	Voltage (0-10 V)	EA5E150Q	EA5R150XK2Q
300 mm	60			EA5E300Q	EA5R300XK2Q
450 mm	90			EA5E450Q	EA5R450XK2Q
600 mm	120			EA5E600Q	EA5R600XK2Q
750 mm	150			EA5E750Q	EA5R750XK2Q
900 mm	180			EA5E900Q	EA5R900XK2Q
1050 mm	210			EA5E1050Q	EA5R1050XK2Q
1200 mm	240			EA5E1200Q	EA5R1200XK2Q
1500 mm	300			EA5E1500Q	EA5R1500XK2Q
1800 mm	360			EA5E1800Q	EA5R1800XK2Q
2100 mm	420			EA5E2100Q	EA5R2100XK2Q
2400 mm	480			EA5E2400Q	EA5R2400XK2Q

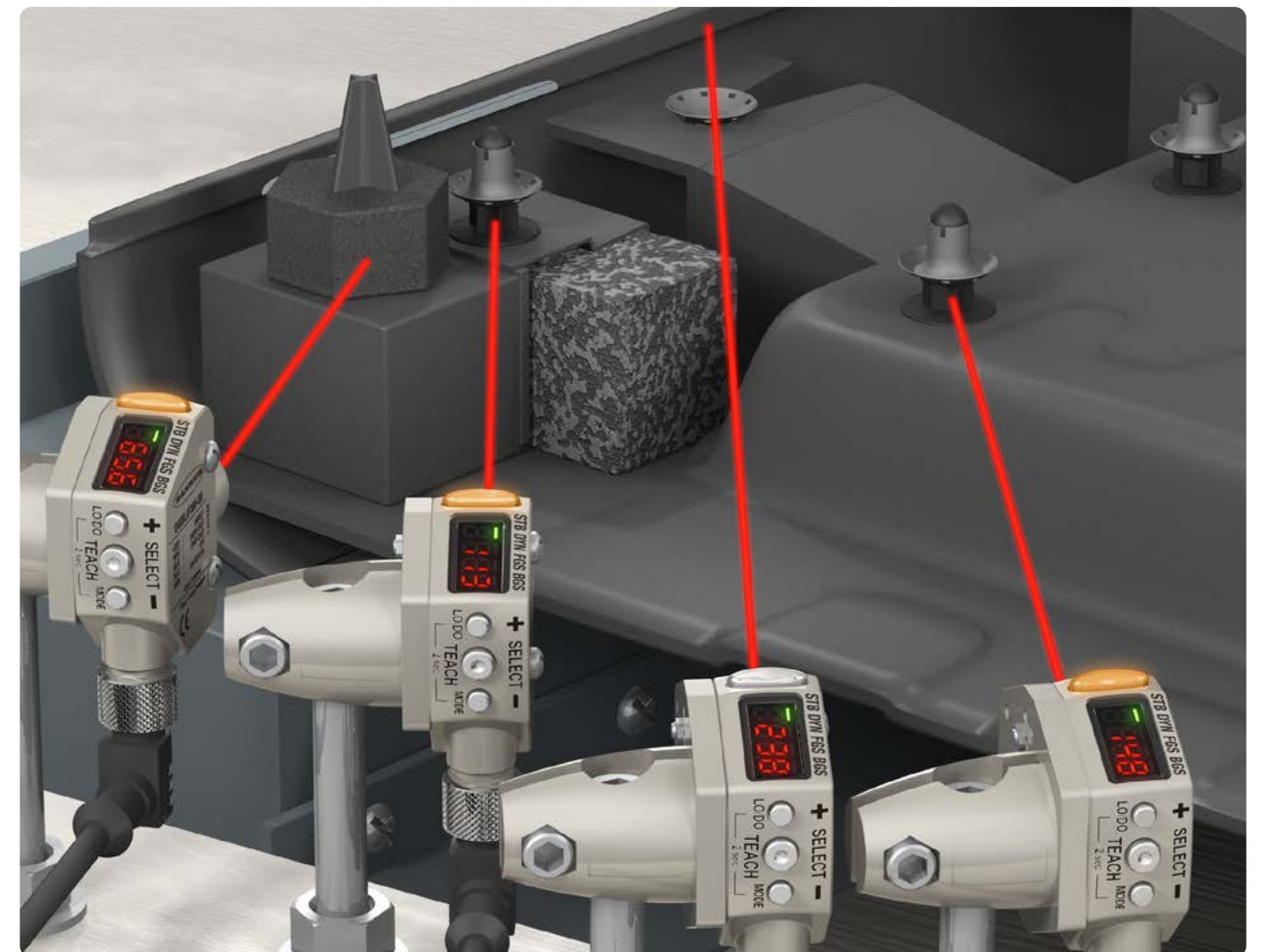



WLS15 Pro LED Strip Lights

- Provides operator guidance for assembly and manufacturing processes
- Configurable, dynamic indication in a slim, sealed LED strip light
- Nineteen color options plus animations and direct sensor interface give limitless options to convey status, resulting in clear communication

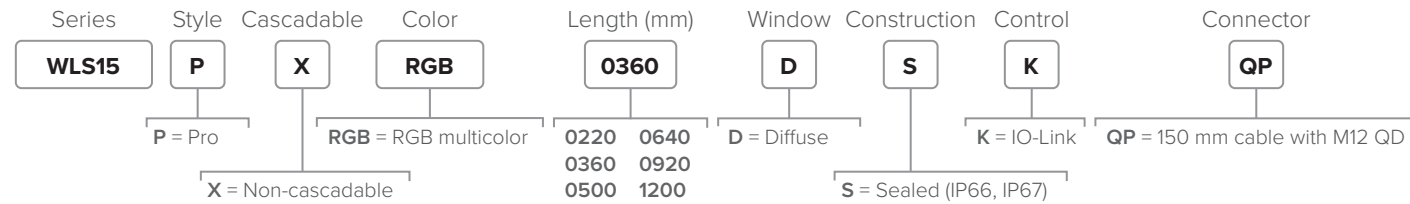

WLS27 Pro LED Strip Lights

- Programmable models with RGBW LEDs for use in indication, illumination, and inspection applications
- IO-Link helps reduce costs, increase process efficiency, and improves machine availability

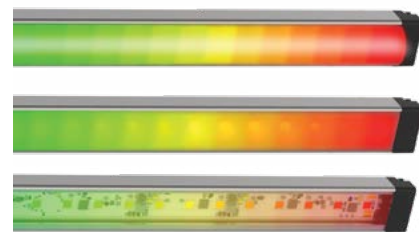
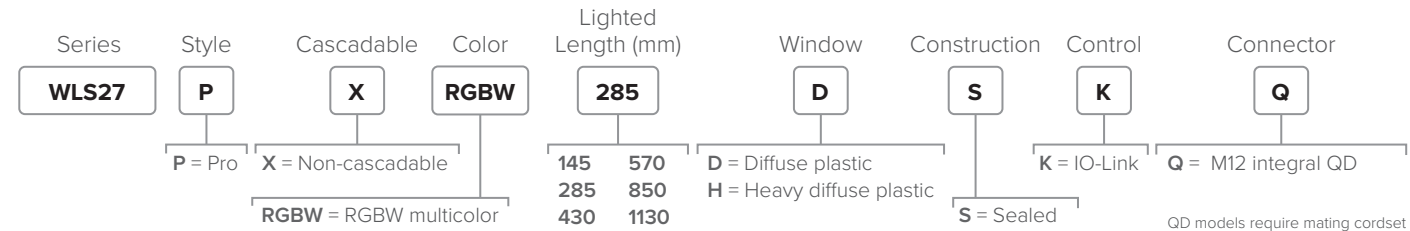

WLS28 Pro LED Strip Lights

- High quality illumination and indication from RGBW LEDs
- Six white color temperatures for comfort and compatibility
- Thirteen color options for varied indication and inspection uses
- IO-Link gives full access to individual LED control, color, flashing, intensity, and animation settings, as well as advanced operating modes for displaying distance, count, time, and position

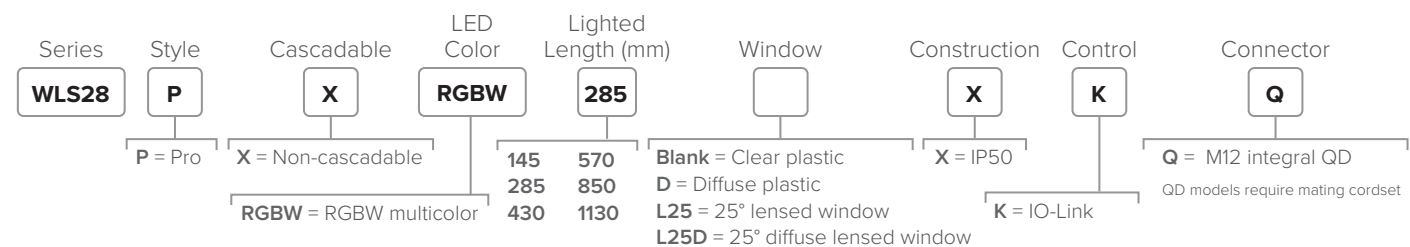

TL50 Pro Tower Lights

- Up to ten segments for advanced status signaling and high-resolution process details
- Advanced animations like level, timer, counter, and action mode provide dynamic visual response
- Parameter and process data options on IO-Link models enable fast and complete control of functionality

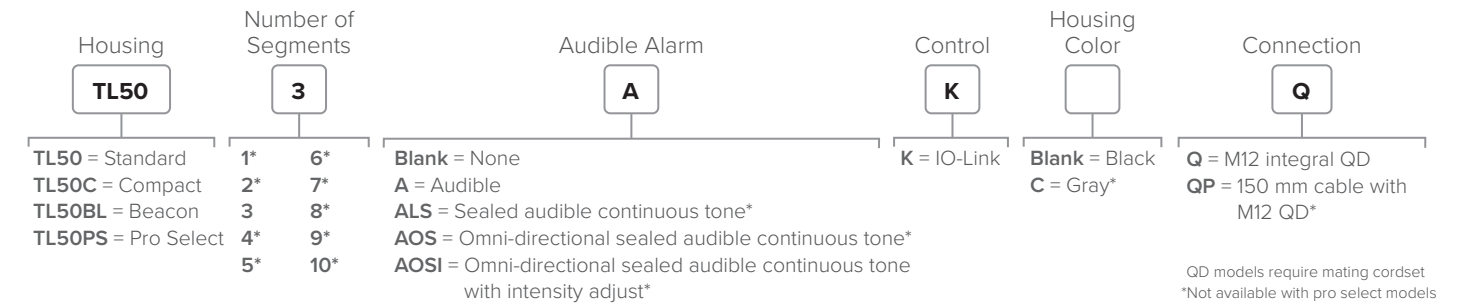

QD models require mating cordset
*Not available with pro select models



TL70 Pro Tower Lights

- Pro series tower lights provide classic segment control as well as advanced status indication that adds nuance to the visual factory
- Allows users to configure color, flashing, rotation, and light intensity
- Models with IO-Link communication enable almost limitless capacity for custom indication

Preassembled Pro Models with IO-Link

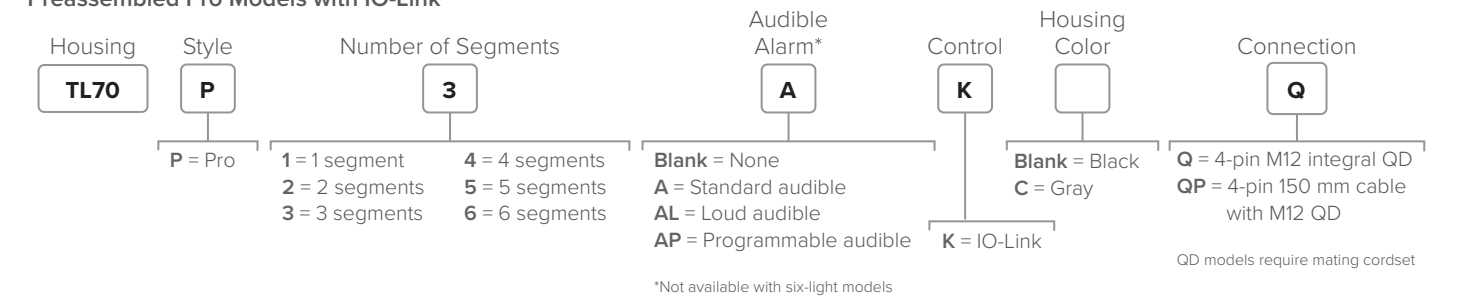

*Not available with six-light models



CL50 Pro Column Lights

- Rugged, versatile, and easy-to-install multicolor indicators
- Bright, easy-to-see operator guidance and indication of equipment status
- Customized indication possibilities, including color, flash patterns, and light intensity
- Audible models available with sealed, omni-directional audible element

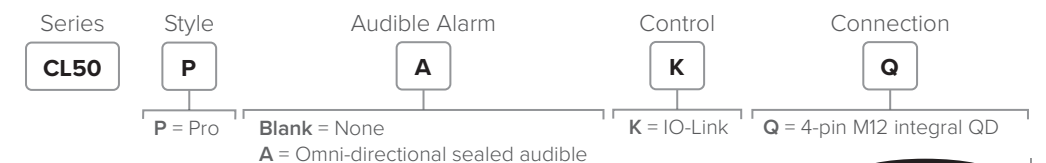



K30 Pro Indicators

- IO-Link models give full access to color, flashing, rotating, and dimming settings as well as advanced animations such as dynamic sequence mode and LED control
- Polycarbonate housing protects against impact and withstands high-pressure, high-temperature washdown to ensure reliable performance in challenging environments

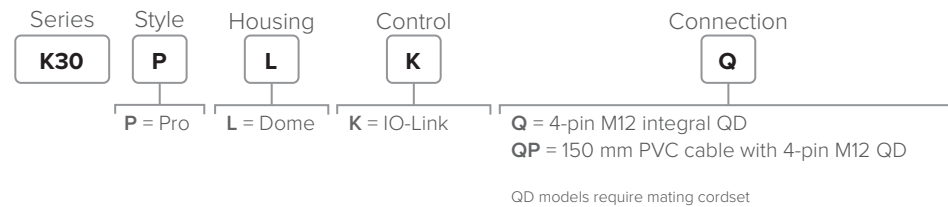

K50 Pro Beacon Indicators

- Bright indicator with individually visible LEDs
- Intense levels of light output for areas with high ambient light, including outdoor environments
- IO-Link control allows access to full color, flashing, and dimming controls as well as advanced animations for millions of color possibilities

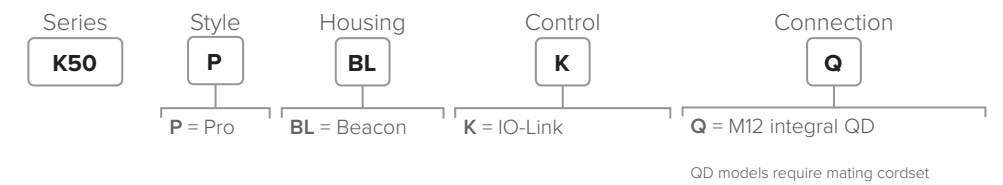

K50 Pro Indicators

- Bright, uniform indicator light
- Fourteen color options including: green, red, yellow, blue, white, cyan, magenta
- IO-Link models give full access to color, flashing, rotating, and dimming settings as well as advanced animations such as dynamic sequence mode and LED control

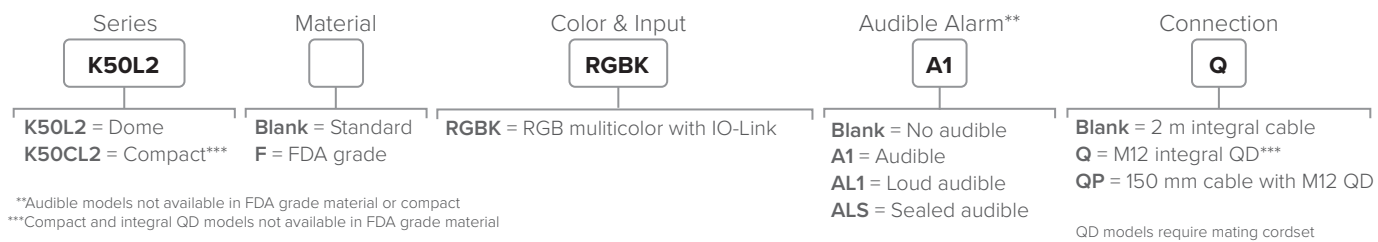

K50 Pro Touch with Display Indicators

- Four-digit, seven-segment LED display with two independent touch areas
- Clearly communicate status and receive feedback, improving throughput and productivity
- Ideal interface device for pick-to-light, condition monitoring, and general operator interaction in industrial environments

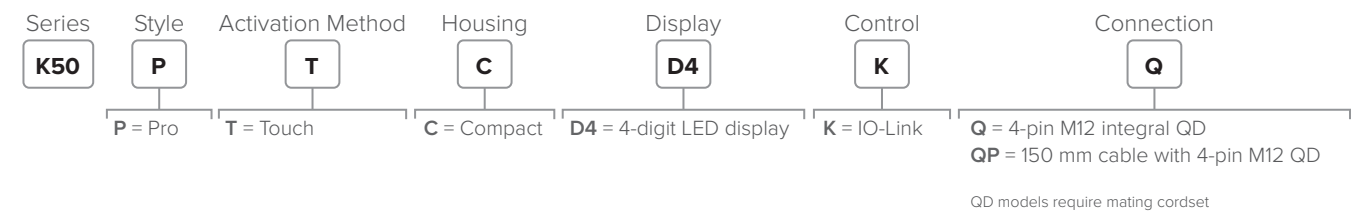



K50 Optical Touch Button Indicators

- Rugged, cost-effective, and easy-to-install solutions for error-proofing and parts-verification applications
- Illuminated dome provides easy-to-see job light status
- Up to fourteen standard colors in one device
- IO-Link models enable color and animation customization, managed dynamically by the master, plus individual LED control
- Sequence mode can be used to indicate level, takt time, and more

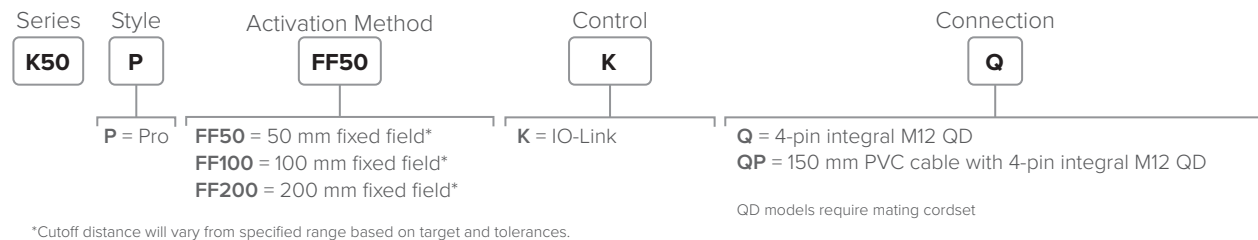

K90 Pro Indicators

- Large, bright, uniform indicator light
- Seven default colors in one device (green, red, yellow, blue, white, cyan, magenta)
- IO-Link models provide access to full color, flashing, and dimming controls as well as advanced animations for millions of color possibilities

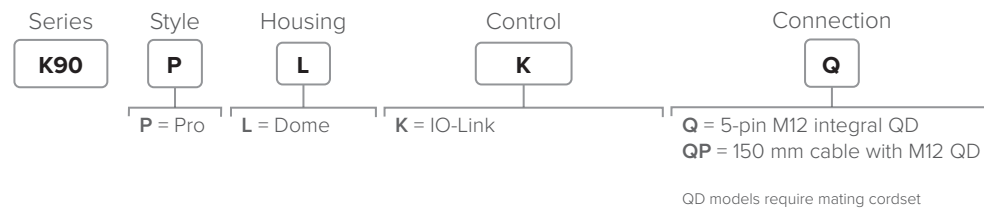

K30 Pro Touch Button Indicators

- Excellent immunity to false triggering by water spray, detergents, oils, and other foreign materials
- Up to fourteen colors in one device
- Devices are completely self-contained: No controller needed
- Ergonomically designed to eliminate hand, wrist, and arm stresses associated with repeated switch operation: No physical force required to operate

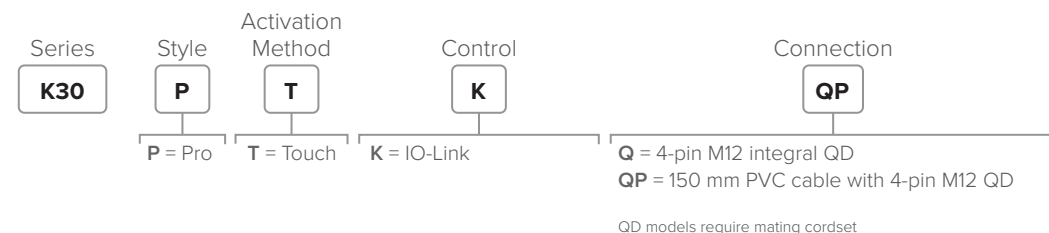

K50 Pro Touch Indicators

- Bright LED indicators combined with touch-activated switching capabilities
- Advanced touch technology allows for high immunity to water while still working with gloves
- Up to fourteen color variations in one device
- Mechanical button models available for traditional, tactile feedback
- Programmable using Banner's IO-Link system for customization of colors and animation

Pro Touch Models with IO-Link or PICK-IQ

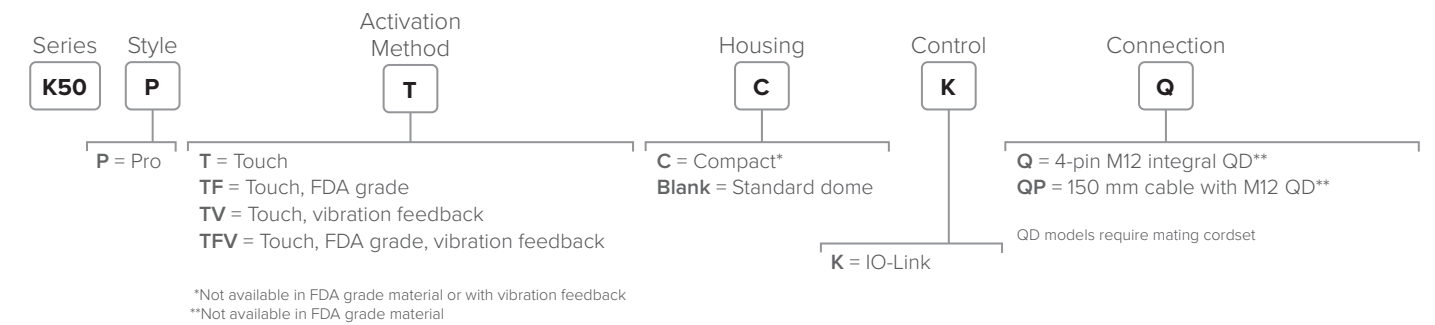

Pro Push Button Models with IO-Link

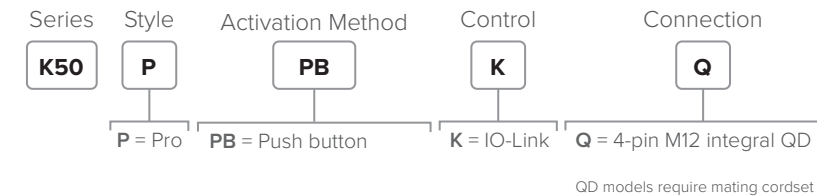

K50 Pro Touch with Audible Indicators

- Integral audible alarm has fourteen tones with customization and intensity control
- Excellent immunity to false triggering by water spray, detergents, oils, and other foreign materials
- Integral audible can be used as standalone indicator or as an input to touch conditions
- Can be actuated with bare hands or gloves
- Compact models available for lower profile applications
- IO-Link models give full access to color, flashing, rotating, and dimming settings as well as advanced animations such as dynamic sequence mode and LED control

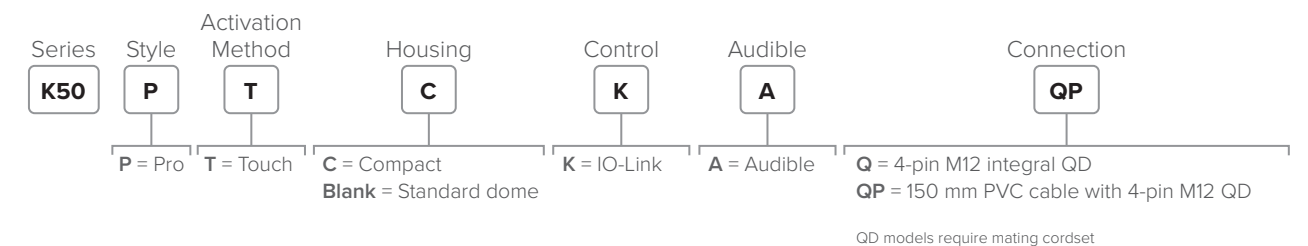

Connect Your Devices

IO-Link products typically incorporate M12 connectors, which are the industry standard for joining devices. IO-Link allows you to standardize on unshielded M12 connectivity which is readily available and cost effective. Any device that does not have an M12 connector can be easily converted using field-wireable M12 connectors.



Cable: PVC jacket, PUR (polyurethane) connector body, nickel-plated brass coupling nut
Conductors: 22 AWG or 24 AWG (open shield only) high-flex stranded, gold-plated contacts
Temperature: -40° to +90° C

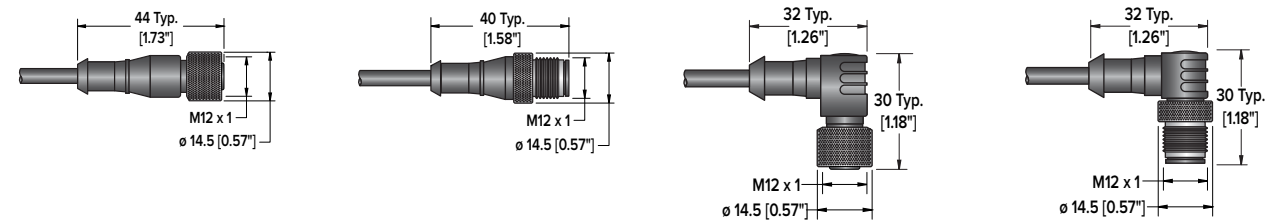

4-Pin M12 Cordsets (Voltage: 250 V DC/AC, Current: 4 A)

	Length	Straight	Right-Angle	Pinout
4-Pin Female QD to Flying Leads	1 m	MQDC-403	—	 Female 1 = Brown 2 = White 3 = Blue 4 = Black
	2 m	MQDC-406	MQDC-406RA	
	3 m	MQDC-410	—	
	5 m	MQDC-415	MQDC-415RA	
	9 m	MQDC-430	MQDC-430RA	
	15 m	MQDC-450	MQDC-450RA	
	18 m	MQDC-460	MQDC-460RA	
	21 m	MQDC-470	MQDC-470RA	
30 m	MQDC-4100	MQDC-4100RA	22 AWG	Cable ϕ – 5.2 mm

4-Pin Male QD to Flying Leads	2 m	MQDMC-406	MQDMC-406RA	 Male 1 = Brown 2 = White 3 = Blue 4 = Black	
	5 m	MQDMC-415	MQDMC-415RA		
	9 m	MQDMC-430	MQDMC-430RA		
				22 AWG	Cable ϕ – 5.2 mm

	Length	Straight/Straight (female/male)	Straight/Right-Angle (female/male)	Pinout
4-Pin Double-Ended	0.3 m	MQDEC-401SS	MQDEC-401SR	 Female 1 = Brown 2 = White 3 = Blue 4 = Black Male 1 = Brown 2 = White 3 = Blue 4 = Black
	0.6 m	MQDEC-402SS	—	
	0.9 m	MQDEC-403SS	MQDEC-403SR	
	1.8 m	MQDEC-406SS	MQDEC-406SR	
	3.0 m	MQDEC-410SS	—	
	3.6 m	MQDEC-412SS	MQDEC-412SR	
	4.5 m	MQDEC-415SS	MQDEC-415SR	
	6.1 m	MQDEC-420SS	MQDEC-420SR	
	9.2 m	MQDEC-430SS	MQDEC-430SR	
	15.2 m	MQDEC-450SS	MQDEC-450SR	

Note: Not all models are shown. Please contact Banner for other available double-ended styles.

5-Pin M12 Cordsets (Voltage: 60 V DC/AC, Current: 4 A)

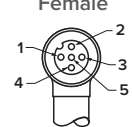
	Length	Straight	Right-Angle	Pinout
 5-Pin Female QD to Flying Leads	0.9 m	MQDC1-503	—	 Female 1 = Brown 2 = White 3 = Blue 4 = Black 5 = Gray 22 AWG Cable ø – 5.6 mm
	2 m	MQDC1-506	MQDC1-506RA	
	5 m	MQDC1-515	MQDC1-515RA	
	9 m	MQDC1-530	MQDC1-530RA	
	19 m	MQDC1-560	—	
30 m	MQDC1-5100	—	—	

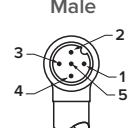
 5-Pin Male QD to Flying Leads	2 m	MQDMC-506	MQDMC-506RA	 Male 1 = Brown 2 = White 3 = Blue 4 = Black 5 = Gray 22 AWG Cable ø – 5.6 mm
	5 m	MQDMC-515	MQDMC-515RA	
	9 m	MQDMC-530	MQDMC-530RA	

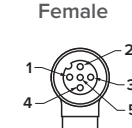
	Length	Straight/Straight (female/male)	Straight/Right-Angle	Pinout
 5-Pin Double-Ended	0.3 m	MQDEC-501SS	—	 Female 1 = Brown 2 = White 3 = Blue 4 = Black 5 = Gray 22 AWG Cable ø – 5.6 mm
	1 m	MQDEC-503SS	—	
	2 m	MQDEC-506SS	—	
	5 m	MQDEC-515SS	—	

Note: Not all models are shown. Please contact Banner for other available double-ended styles.

M12 Splitters

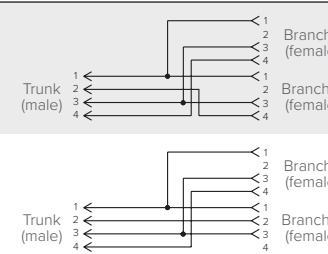

	Models	Cable Lengths		Wiring Diagrams
		Branches (Female)	Trunk (Male)	
4-Pin	S15YA4-M124-M124-0.2M	2 x 0.2 m	No Trunk	
	S15YA24-M124-M124-0.2M			

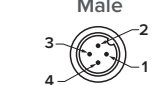
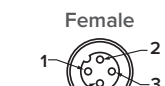

M12 Field Wireables

	Male/Female	Straight	Pinout
 4-Pin M12 Field Wireable	Male	BFW-M12M4-6X	 Male 1 = Brown 2 = White 3 = Blue 4 = Black
	Female	BFW-M12F4-6X	 Female 1 = Brown 2 = White 3 = Blue 4 = Black

 5-Pin M12 Field Wireable	Male	BFW-M12M5-6X	 Male 1 = Brown 2 = White 3 = Blue 4 = Black 5 = Gray
	Female	BFW-M12F5-6X	 Female 1 = Brown 2 = White 3 = Blue 4 = Black 5 = Gray

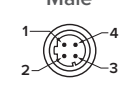
Ethernet Cordsets

	Length	Straight	Pinout
 4-Pin Male M12 to RJ45	2 m	STP-M12D-406	 RJ45 1 = White/orange 2 = Orange 3 = White/blue 6 = Blue
	5 m	STP-M12D-415	 Male 1 = White/orange 2 = White/blue 3 = Orange 4 = Blue
	9 m	STP-M12D-430	2 x 24 Pair AWG Cable ø – 6.2 mm UTP Stranded

 4-Pin Male M12 to 4-Pin Male M12	0.3 m	BCD-M12DM-M12DM-0.3M	 Male 1 = White/orange 2 = White/green 3 = Orange 4 = Green
	1 m	BCD-M12DM-M12DM-1M	2 x 24 Pair AWG Cable ø – 6.2 mm UTP Stranded

Accessories



LMBM12MAG
Attaches to M12 cordset end (magnetic)



BWA-M12CAB-MAG
Attaches to M12 cable (magnetic)



LMBM12SP
Attaches to M12 cordset end



ACC-CAP M12-10
Protective end cap



LMBS15MAG
Attaches to S15C (magnetic)



LMBS15SP
Attaches to S15C

Convert to a Unified Protocol

Legacy devices are common in most industrial settings. These devices have data outputs that include discrete NPN/PNP signals, 4–20 mA signals, 0–10 V signals, and many more types. You can incorporate all these disparate signals into your IO-Link system with Banner's extensive line of IO-Link converters and hubs. After the physical connections are made, the next step is to get all the devices speaking the same language. With Banner IO-Link products, all these signals can be quickly converted to a unified communications protocol. This enables facilities to build a flexible IO-Link network. Many of Banner's IO-Link converters are the size of an AA battery, are simply inserted inline via an M12 connector, and can begin converting signals the instant they're installed.



S15C Converter

Break free from protocol limitations with S15C in-line converters. S15C converters take various types of signals such as discrete, analog, and others and convert these signals to smart protocols like IO-Link. This makes it easy to incorporate existing legacy sensors into a standard protocol to enable process monitoring. S15C Converters are designed to connect directly to a sensor, indicator, or other device and begin operating immediately, fitting seamlessly into your factory applications.

- Previously incompatible devices can be connected to a smart system
- Compact form factor
- Rugged over-molded design meets IP65, IP67, and IP68 standards
- Simple M12 connection for easy installation wherever needed in the circuit

S15C Converter

Easily converts signals like 4–20 mA analog to IO-Link without any setup required

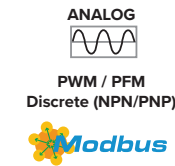

- I = 4–20 mA
- U = 0–10 V DC
- B21 = Discrete Input/Output
- MGN = Modbus
- MGP = Modbus GPS
- MVT = Modbus V/T Sensor
- MEZ = EZ-ARRAY
- MTH = Modbus T/H Sensor
- MUL = Modbus Ultrasonic Sensor

R45C IO-Link to Analog Out Converter

- Compact analog to IO-Link device converter outputs an analog value, voltage, or current, as presented by the IO-Link Master
- Rugged over-molded design meets IP65, IP67, and IP68 standards
- Connects directly to a sensor or anywhere in-line for ease of use

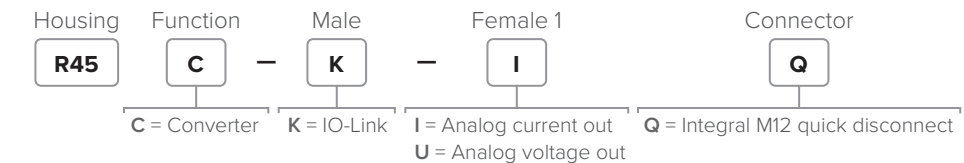



R45C IO-Link to Analog Input-Output Converter

- Compact IO-Link device to analog converter that outputs an analog value, voltage or current, as presented by the IO-Link Master
- The converter also connects to an analog source, voltage or current, and outputs the value to the IO-Link Master
- Rugged over-molded design meets IP65, IP67, and IP68 standards
- Connects directly to a sensor or anywhere in-line for ease of use

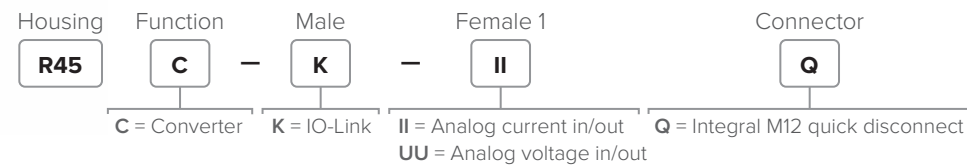

R45C IO-Link to Dual Analog Input-Output Converter

- Compact IO-Link device to analog converter that outputs an analog value, voltage or current, as presented by the IO-Link master
- The converter also connects to an analog source, voltage or current, and outputs the value to the IO-Link master and as a representative PFM output
- Rugged over-molded design meets IP65, IP67, and IP68 standards
- Connects directly to a sensor or anywhere in-line for ease of use

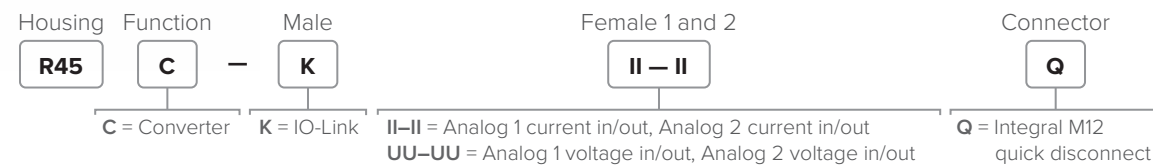

R130C Discrete IO-Link Hub

- Cost-efficiently integrate up to 16 devices into an IO-Link system
- Simplify wiring and installation with M12 QD cables
- Minimize the size of the control panel by locating I/O remotely on the machine, closer to sensors and other devices
- Provide power to lighting products and other devices that draw higher current with 4 amps shared across ports
- Streamline troubleshooting with I/O status LEDs viewable from top or side of device

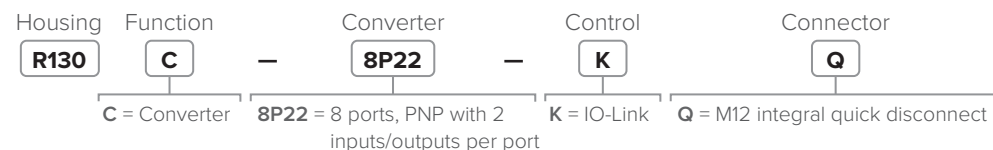

R90C Discrete IO-Link Hub

- Connect two discrete signals to each of the unique ports, providing access to monitoring and configuring those ports with an IO-Link Master
- Host mirroring is available where a selected port input/output discrete signal can be routed to Pin 2 (male) on the PLC/Host connection

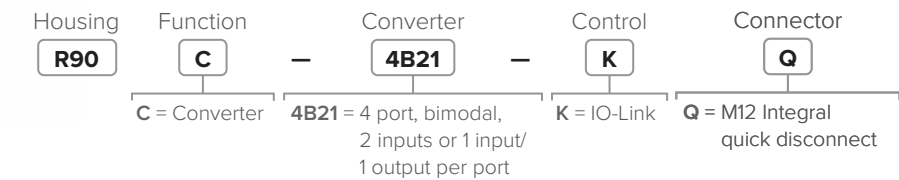

R95C Discrete IO-Link Hub

- Connect two discrete signals to each of the unique ports, providing access to monitoring and configuring those ports with an IO-Link Master
- Host mirroring is available where a selected port input/output discrete signal can be routed to Pin 2 (male) on the PLC/Host connection

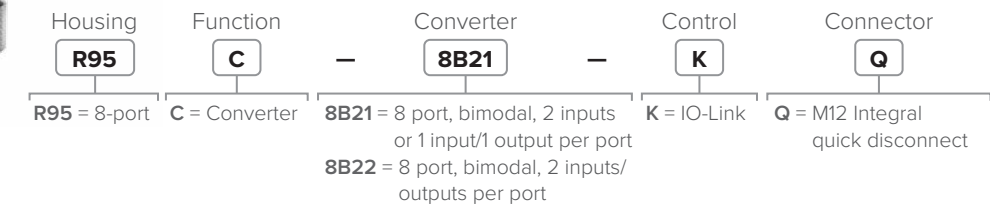

R95C Discrete and Analog Input-Output IO-Link Hub

- Compact IO-Link device converter with the ability to send 4 ports of discrete input and 4 ports of analog input data (voltage or current) to an IO-Link Master
- The IO-Link Master Process Data Output can also output discrete values and analog outputs (voltage or current) through any of the respective sets of 4 ports
- Rugged overmolded design meets IP65, IP67, and IP68

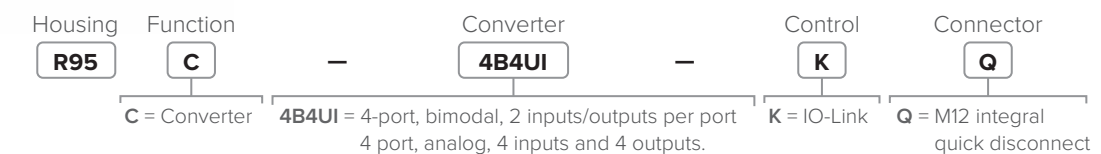

IO-Link® HUBS & CONVERTERS



R95C Analog Input to IO-Link Hub

- Compact analog to IO-Link device converter that receives an analog source and outputs the value to the IO-Link master
- R95C IO-Link hubs are a quick, easy, and economical way to integrate non-IO-Link devices into an IO-Link system
- Rugged over-molded design meets IP65, IP67, and IP68 standards
- Connects directly to a sensor or anywhere in-line for ease of use



Accessories



Integrate Analog Devices Into Your IO-Link System

Banner's R95C 8-port Analog Input IO-Link Hub simplifies adding analog devices to an IO-Link system. It takes up to eight analog signal inputs (either current or voltage) and consolidates them into one IO-Link data stream. The R95C reduces the need for shielded cabling, using simple 4-wire M12 cordsets and connections to save installation time and hardware costs, while eliminating the need for expensive PLC analog input cards.

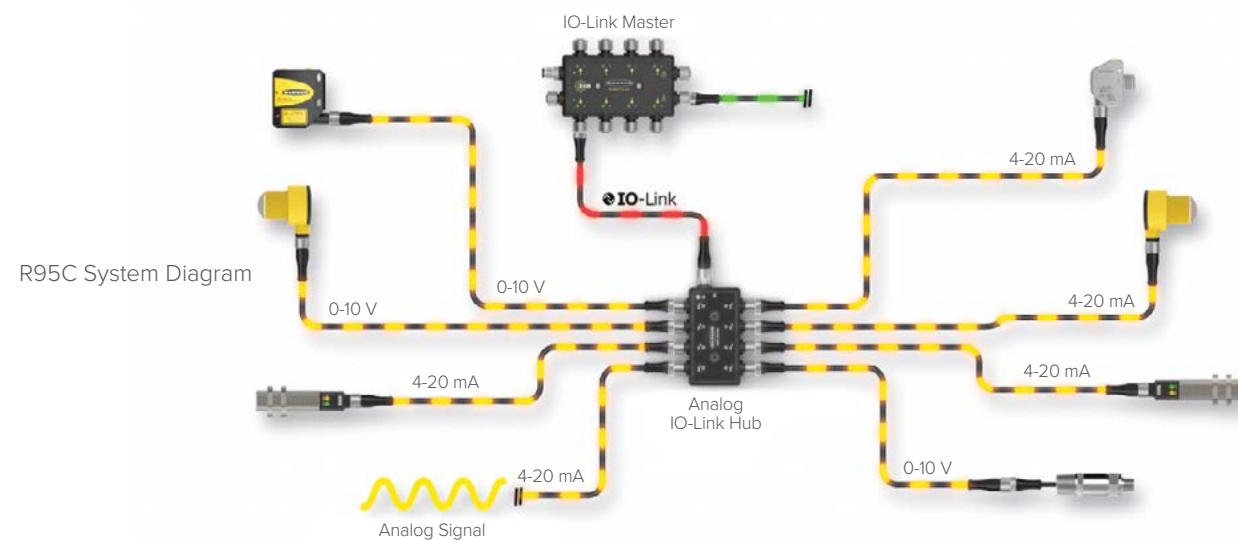

Build Your Network

Banner IO-Link masters serve as the gateway for the connection of IO-Link devices, including sensors, lighting products, IO-Link Hubs, and more. Banner IO-Link masters are the most compact in the industry and enable users to flexibly send IO-Link data where it needs to go, whether it's to a PLC, HMI, SCADA or cloud platform such as Banner CDS.



DXMR90-4K Multiprotocol IO-Link Master

The DXMR90-4K IO-Link Master houses a processor that receives signals from sensors and other connected devices through four dedicated IO-Link ports. As a centralized hub, the DXMR90 combines all these signals into one unified stream of insightful data, which can be exported via industrial Ethernet protocols. The controller also has advanced programmability via scriptbasic and action rules that allows facilities to use the IO-Link master as a controller in a standalone application, eliminating the need for a PLC. The DXMR90-4K IO-Link Master also has a Modbus RTU client port for expanding your connection possibilities.



Ethernet Connection	Master Connections	Other Connections	Models
One female M12 D-Code Ethernet connector	Four female M12 connections for IO-Link	One male M12 (Port 0) for incoming power and Modbus RS-485, one female M12 for daisy chaining Port 0 signals	DXMR90-4K

Connect More Devices with Ease

The DXMR90-4K allows for the connection and control of up to four IO-Link devices, replacing multiple traditionally expensive input cards. The DXMR90-4K can communicate with higher-level control systems via EtherNet/IP, Modbus/TCP, and PROFINET. This IO-Link master also has an additional serial port that allows for the connection of more devices for maximum flexibility.

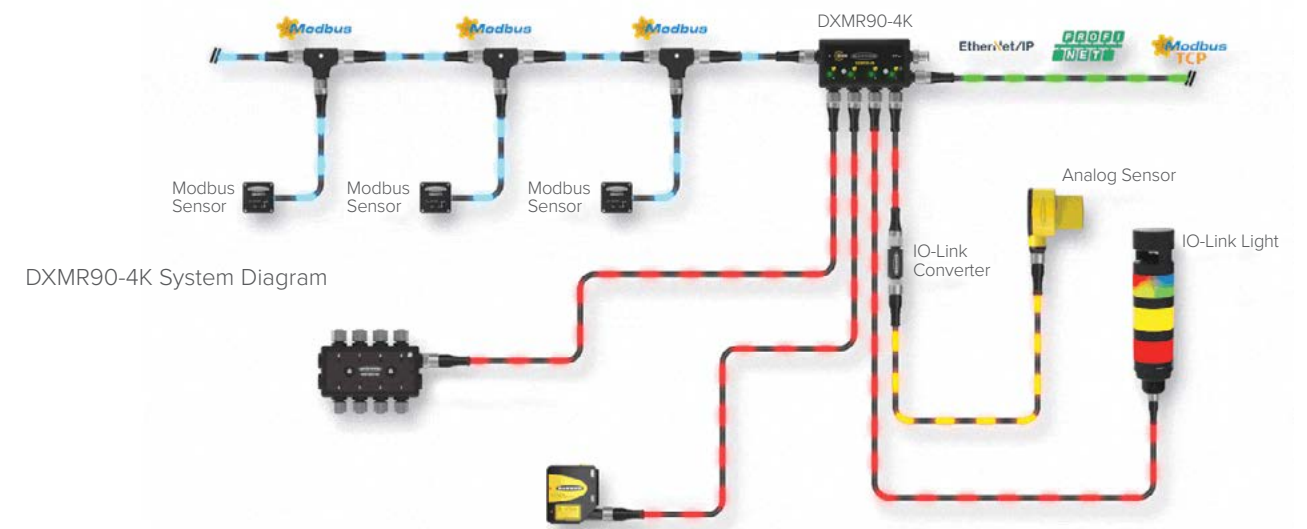

Accessories



SMBR90S Mounting Bracket (use multiples to stack)
SMBR90RA Mounting Bracket
SMBR90RADIN DIN Rail Mounting Bracket
SMBR90RAMAG Magnetic Mounting Bracket
PSW-24-1 Power Supply
STP-M12D-406 Ethernet Cordset



DXMR110-8K Multiprotocol IO-Link Master

- Local control or connectivity with automation protocols, including EtherNet/IP, Modbus/TCP, and PROFINET
- Logic processing and problem-solving capable of deploying solutions to process and control data from multiple devices
- IP67 housing simplifies installation in any location by eliminating the need for a control cabinet
- Consolidation of cable runs to minimize cabling and associated weight, especially in weight-critical applications such as robotics
- Flexible and customizable: Expanded internal logic controller with action rules and ScriptBasic programming

Ethernet Connection	IO-Link Master Connections	Other Connections	Models
Two female M12 D-Code Ethernet connectors for daisy chaining and communication to a higher-level control system	Eight female M12 connections for IO-Link	One male M12 for incoming power, one female M12 for daisy chaining power	DXMR110-8K

Streamline Your IO-Link Network

The compact DXMR110-8K allows for the connection and control of up to eight IO-Link devices, such as sensors, indicator lights, or IO-Link hubs, without the need for multiple traditionally expensive input cards. The DXMR110-8K can communicate with higher-level control systems via EtherNet/IP, Modbus/TCP, and PROFINET. The DXMR110-8K also has the ability to push IO-Link data to cloud platforms.

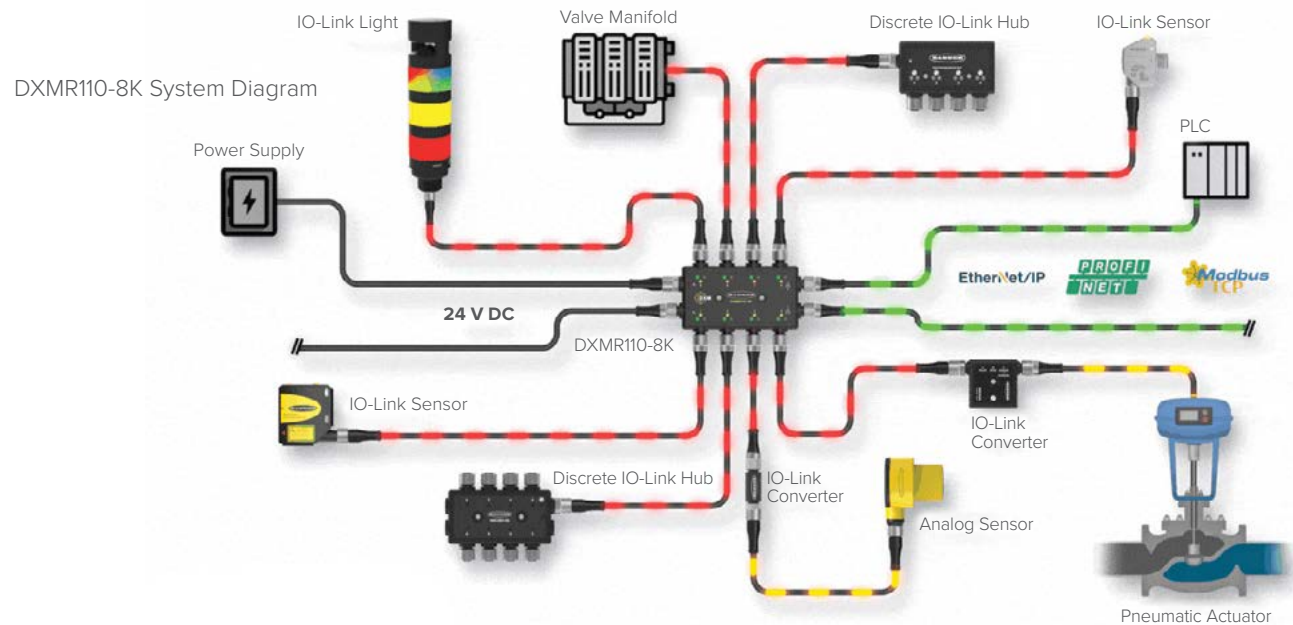

No IO-Link Device? No problem. Our expansive line of converters can adapt most industrial devices to IO-Link quickly, giving you the flexibility to build the system you need.



R45C IO-Link Master with Modbus RTU Interface

- Connects two IO-Link devices and provides access via Modbus RTU interface
- Rugged design: Easy installation with no assembly or individual wiring required
- 5-pin M12 male quick-disconnects
- Two 4-pin M12 female quick-disconnects
- Built-in indication for two IO-Link master ports
- Built-in indication for Modbus RTU connection status
- Rugged over-molded design meets IP65, IP67, and IP68 standards



R90C IO-Link Master with Modbus RTU Interface

The R90C 4-Port IO-Link Master connects to four IO-Link devices and provides access to IO-Link data and functionality via a Modbus RTU connection. Modbus registers allow for access to both IO-Link devices and their functions:

- Process Data In
- Process Data Out
- Connected device information
- ISDU data
- Discrete I/O configuration
- IO-Link events
- Data storage
- SIO mode

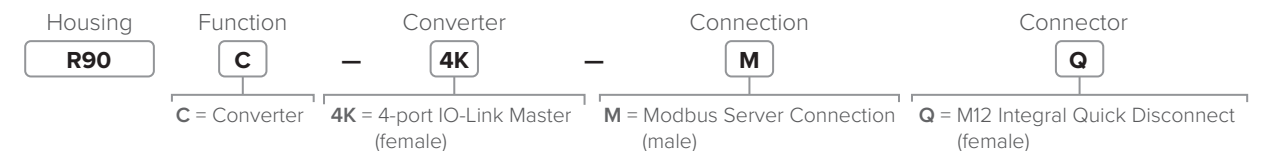

Consume Data to Optimize Productivity

IO-Link data is typically sent to a higher-level control system or a supervisory device. This can be a programmable logic controller (PLC), a distributed control system (DCS), a human-machine interface (HMI), a cloud dashboard such as Banner Cloud Data Services, or any other compatible device that can process and interpret the IO-Link data. The specific destination depends on the system architecture and the intended application of the IO-Link communication.



Monitor Your Equipment from Anywhere

The Cloud Data Services software is a web-based platform that allows users to access, store, protect, and export critical data collected by Banner Snap Signal solutions. The software complements the Snap Signal portfolio and provides customers with complete end-to-end IIoT solutions to solve the industrial market's most pressing problems.

Banner Cloud Data Services (CDS)

- The CDS platform is more than a dashboard. With analytics and visualization tools, the software delivers actionable insights that allow you to solve real challenges on the factory floor.
- Users can remotely access data anytime and anywhere using an internet-connected device. In addition, they can define parameters to control when to receive notifications via email or SMS message. On-demand visibility and real-time alerts allow remote monitoring and diagnosis of systems quickly.
- Predictive maintenance is a key capability of Banner's IIoT solutions. The CDS platform helps you use device data to predict machine maintenance requirements, which reduces unplanned downtime, increases mean time between failure (MTBF), and reduces maintenance costs.
- Data transmissions from your controller are secured via several layers of protection including a proprietary communication protocol and generic data transfer. In addition, data transmissions from the controller to the cloud are securely encrypted.

HMI, SCADA, PLC, or Other Monitoring Platforms

- IO-Link's unique open architecture allows you to send data where you need it.
- Banner's IO-Link masters support EtherNet/IP[®], Modbus/TCP, PROFINET, and Modbus RTU, so that data can be interfaced with industrial systems flexibly.



Visit bannercds.com for more information

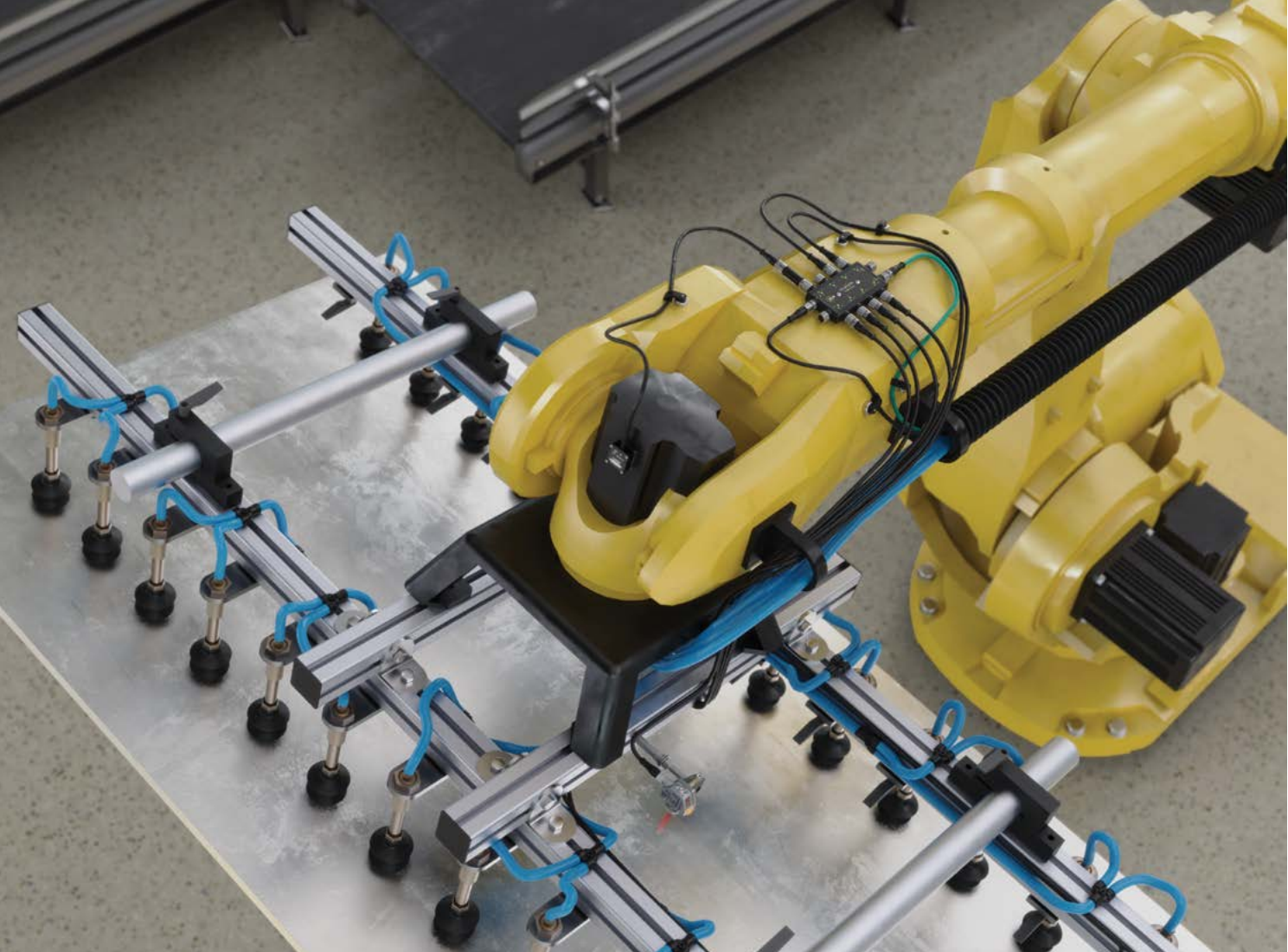

Smarter Automation. Better Solutions.

Banner Engineering designs and manufactures industrial automation products including sensors, smart IIoT and industrial wireless technologies, LED lights and indicators, measurement devices, machine safety equipment, as well as barcode scanners and machine vision. These solutions help make many of the things we use every day, from food and medicine to cars and electronics. A high-quality, reliable Banner product is installed somewhere around the world every two seconds. Headquartered in Minneapolis since 1966, Banner is an industry leader with more than 10,000 products, operations on five continents, and a world-wide team of more than 5,500 employees and partners. Our dedication to innovation and personable service makes Banner a trusted source of smart automation technologies to customers around the globe.

