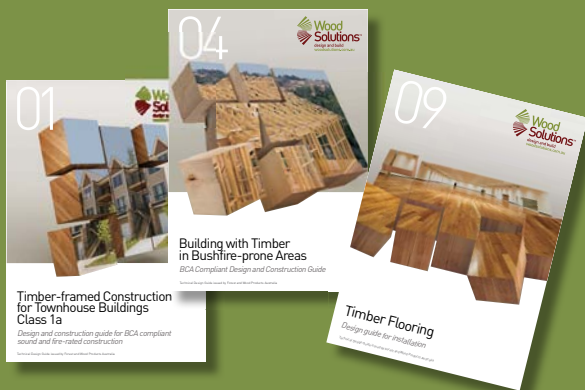


08



# Stairs, Balustrades and Handrails

*Class 1 Buildings - Construction*



## Technical Design Guides

A growing suite of information, technical and training resources created to support the use of wood in the design and construction of buildings.

Topics include:

- #01 Timber-framed Construction for Townhouse Buildings Class 1a
- #02 Timber-framed Construction for Multi-residential Buildings Class 2, 3 & 9c
- #03 Timber-framed Construction for Commercial Buildings Class 5, 6, 9a & 9b
- #04 Building with Timber in Bushfire-prone Areas
- #05 Timber service life design – Design Guide for Durability
- #06 Timber-framed Construction – Sacrificial Timber Construction Joint
- #07 Plywood Box Beam Construction for Detached Housing
- #08 Stairs, Balustrades and Handrails Class 1 Buildings – Construction
- #09 Timber Flooring – Design Guide for Installation
- #10 Timber Windows and Doors
- #11 Noise Transport Corridor Design Guide
- #12 Impact and Assessment of Moisture-affected, Timber-framed Construction
- #13 Finishing Timber Externally
- #14 Timber in Internal Design
- #15 Building with Timber for Thermal Performance
- #16 Massive Timber Construction Systems Cross-laminated Timber (CLT)

## Other WoodSolutions Publications

R-Values for Timber-framed Building Elements

**To view all current titles or for more information visit [woodsolutions.com.au](http://woodsolutions.com.au)**



WoodSolutions is an industry initiative designed to provide independent, non-proprietary information about timber and wood products to professionals and companies involved in building design and construction.

WoodSolutions is resourced by Forest and Wood Products Australia (FWPA). It is a collaborative effort between FWPA members and levy payers, supported by industry peak bodies and technical associations.

This work is supported by funding provided to FWPA by the Commonwealth Government.

ISBN 978-1-921763-16-8

### Prepared by:

Colin MacKenzie  
Timber Queensland Limited

First produced: April 2007

Revised: May 2012, October 2013

**© 2012 Forest and Wood Products Australia Limited. All rights reserved.**

These materials are published under the brand WoodSolutions by FWPA.

### IMPORTANT NOTICE

Whilst all care has been taken to ensure the accuracy of the information contained in this publication, Forest and Wood Products Australia Limited and WoodSolutions Australia and all persons associated with them (FWPA) as well as any other contributors make no representations or give any warranty regarding the use, suitability, validity, accuracy, completeness, currency or reliability of the information, including any opinion or advice, contained in this publication. To the maximum extent permitted by law, FWPA disclaims all warranties of any kind, whether express or implied, including but not limited to any warranty that the information is up-to-date, complete, true, legally compliant, accurate, non-misleading or suitable.

To the maximum extent permitted by law, FWPA excludes all liability in contract, tort (including negligence), or otherwise for any injury, loss or damage whatsoever (whether direct, indirect, special or consequential) arising out of or in connection with use or reliance on this publication (and any information, opinions or advice therein) and whether caused by any errors, defects, omissions or misrepresentations in this publication. Individual requirements may vary from those discussed in this publication and you are advised to check with State authorities to ensure building compliance as well as make your own professional assessment of the relevant applicable laws and Standards.

The work is copyright and protected under the terms of the Copyright Act 1968 (Cwth). All material may be reproduced in whole or in part, provided that it is not sold or used for commercial benefit and its source (Forest & Wood Products Australia Limited) is acknowledged and the above disclaimer is included. Reproduction or copying for other purposes, which is strictly reserved only for the owner or licensee of copyright under the Copyright Act, is prohibited without the prior written consent of FWPA.

WoodSolutions Australia is a registered business division of Forest and Wood Products Australia Limited.

# Table of Contents

<b>Introduction</b>	<b>5</b>
<b>1. Types of Stair Construction</b>	<b>6</b>
1.1 Straight Stairs . . . . .	7
1.2 Straight Stairs with Intermediate Landing . . . . .	7
1.3 Newel Stairs . . . . .	7
1.4 Open Newel Stair . . . . .	8
1.5 Dog-leg Stair . . . . .	8
1.6 Winders . . . . .	8
1.7 Geometrical Stairs . . . . .	9
<b>2. BCA Requirements</b>	<b>10</b>
2.1 General . . . . .	10
2.2 Stairs . . . . .	10
2.3 Balustrades and Handrails . . . . .	11
<b>3. Materials for External Stairs Without Riser Boards (Open Stairs)</b>	<b>13</b>
3.1 Timber Durability and Species . . . . .	13
3.2 Timber Grade . . . . .	15
3.3 Moisture Content . . . . .	15
3.4 Joint Priming . . . . .	15
3.5 Corrosion Protection of Fasteners . . . . .	15
3.6 Termite Protection . . . . .	16
3.7 Slip Resistance . . . . .	17
3.8 Sizes . . . . .	17
<b>4. Materials for Internal Stairs – With and Without Riser Boards (Open and Closed Stairs)</b>	<b>18</b>
4.1 Timber Durability and Species . . . . .	18
4.2 Timber Grade . . . . .	19
4.3 Moisture Content . . . . .	20
4.4 Termite Protection . . . . .	20
4.5 Slip Resistance . . . . .	20
4.6 Span Tables . . . . .	20
<b>5. Stair Construction Procedure</b>	<b>21</b>
5.1 Margin Template and Pitch Board . . . . .	21
5.2 Marking Out Strings . . . . .	23
5.3 Housing Strings . . . . .	26
5.4 String End Joints . . . . .	27
5.5 Step Bolts (Tie Bolts) . . . . .	29
5.6 Assembly . . . . .	30

<b>6. Balustrades and Handrails</b>	<b>31</b>
6.1 Loads . . . . .	.31
6.2 Materials . . . . .	.31
6.3 Member Sizes . . . . .	.32
6.4 Connections . . . . .	.35
<b>7. Weathering, Finishes and Maintenance</b>	<b>38</b>
7.1 External Stairs and Balustrades . . . . .	.38
7.2 Internal Stairs . . . . .	.38
<b>Appendices</b>	<b>40</b>
<b>Appendix A – Glossary</b>	<b>40</b>
A1 General . . . . .	.40
A2 Members in a Staircase . . . . .	.40
A3 Members in a Balustrade. . . . .	.41
A4 Construction Terms. . . . .	.41
<b>Appendix B – Stair Calculations</b>	<b>43</b>
B1 General . . . . .	.43
B2 Example 1 . . . . .	.44
B3 Example 2 . . . . .	.45
B4 Example 3 . . . . .	.46
B5 Headroom for Stairs . . . . .	.47
B6 Practical Method for Calculating Number of Rises and the Rise . . . . .	.49
B7 Quantity Calculations. . . . .	.49
<b>Appendix C – Total Rise Calculations – Sloping Ground</b>	<b>51</b>
C1 Determining Total Rise on Sloping Ground . . . . .	.51

# Introduction

*This guide covers stairs with straight flights, with or without risers for external and internal use and balustrades.*

**Staircase and balustrade work is considered to be a specialised section of carpentry and joinery. This document covers stairs with *straight flights, with or without risers for external and internal use and balustrades.***

Internal stairs are often prepared in a workshop making full use of available machines and equipment. Interior stairs may differ considerably in design, from simple straight flights, commonly used in domestic work, to more elaborate stairs constructed purposely as an attractive feature in public and commercial buildings and in elaborate homes.

Exterior stairs are commonly built from treated softwood and durable hardwoods while interior stairs are commonly built from joinery-quality timber cut and seasoned especially for stairs. The finish for exterior stairs is generally paint and interior stairs is often clear polish, lacquer, etc, therefore both material and workmanship should be of the very highest standard.

The construction procedure described here would be more or less general for all stairs of either conventional or contemporary construction.

At an early stage in the construction of a building having exterior and/or interior stairs, a decision will have to be made on the length of the stairs to determine the location of any foundations, concrete pads, etc, and the opening required in the floor to accommodate internal stairs and provide sufficient headroom. Also, before the timber for the stairs can be ordered, it will be necessary to know the length of the string, newels, landing trimmers, joists, etc, and the number of treads and risers required. Refer to Appendix B for the calculations needed to determine these facts.

## Scope

This guide is intended to be used by the building industry for the design, practices and construction of timber stairs, handrails and balustrades. Information with respect to both internal and external stairs is provided. Also, both open stairs (no risers) and closed stairs (with risers) are catered for. Recommendations are also provided on timber species selection, durability and finishing, etc, and example stair calculations are given in Appendix B and C.

## Disclaimer

The information, opinions, advice and recommendations contained in this publication have been prepared with due care. They are offered only for the purpose of providing useful information to assist those interested in technical matters associated with the specification and use of timber and timber products. Whilst every effort has been made to ensure that this publication is in accordance with current practices and technology, it is not intended as an exhaustive statement of all relevant data. As successful design and construction depends upon numerous factors outside the scope of this publication, the authors and publishers accept no responsibility for errors in, or omissions from, this publication, nor for specifications or work done or omitted in reliance on this publication.

## Regulatory Requirements

This publication focuses on traditional practices and current relevant Building Code of Australia (BCA) requirements. From time to time the BCA is amended and states may also vary requirements. Users of this Guide should make themselves aware of any changes or differences and should develop a full understanding of the resulting implications. Only on this basis should this Guide be used.

*Although national, some BCA provisions differ by state. It's vital to know key elements for your area.*

# 1

## Types of Stair Construction

The design and configuration of stairs can differ markedly depending upon space availability, functionality and desired appearance. This section describes different types of stair configurations and the various components of these.

The common type of stair construction is to house treads into stringers as shown in Figure 1.1. Flights may be constructed with 'open treads' without risers or 'closed treads' with riser boards.

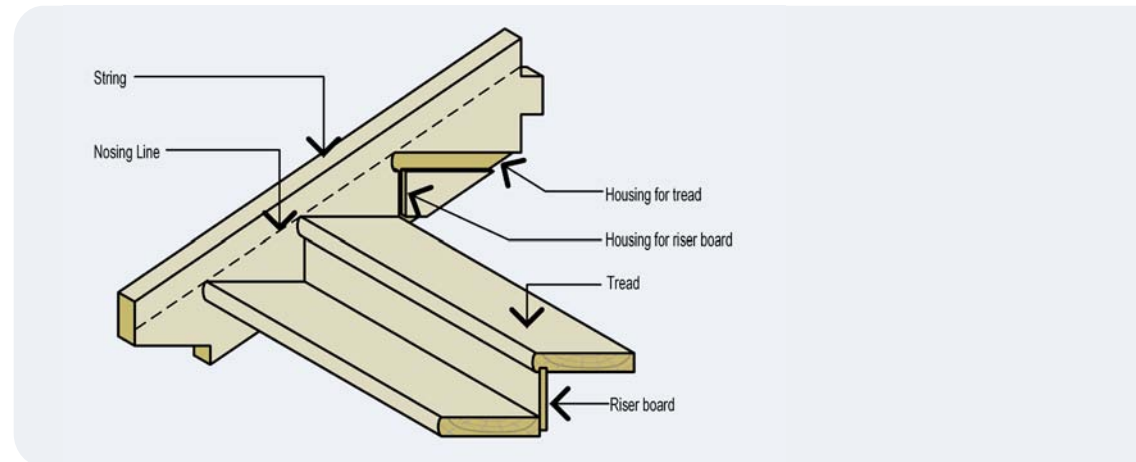


Figure 1.1: Common stair construction.



**Open tread stairs are recommended for external use.**

Closed tread stairs and open tread stairs are suitable for both external and internal use. However open tread stairs are recommended for external use because they give better air circulation allowing the timber to dry out more quickly and therefore improve durability. Metal angle brackets may also be used rather than housing in the treads.

As an alternative to timber, metal may be used for stringers. Metal strings are often used in external locations, but can also be used for internal stairs. They are available in some states with a 'stock' rise and going or can be ordered with a specific rise and going.

Depending on the application, flights can be configured in various ways. The following illustrates some of these.

## 1.1 Straight Stairs

A single flight of stairs having all treads parallel to one another. This form of stair, which is widely used for domestic construction, has no landing and may be enclosed between two walls or built against one wall and the other side open with newels and balustrade (Figure 1.2).

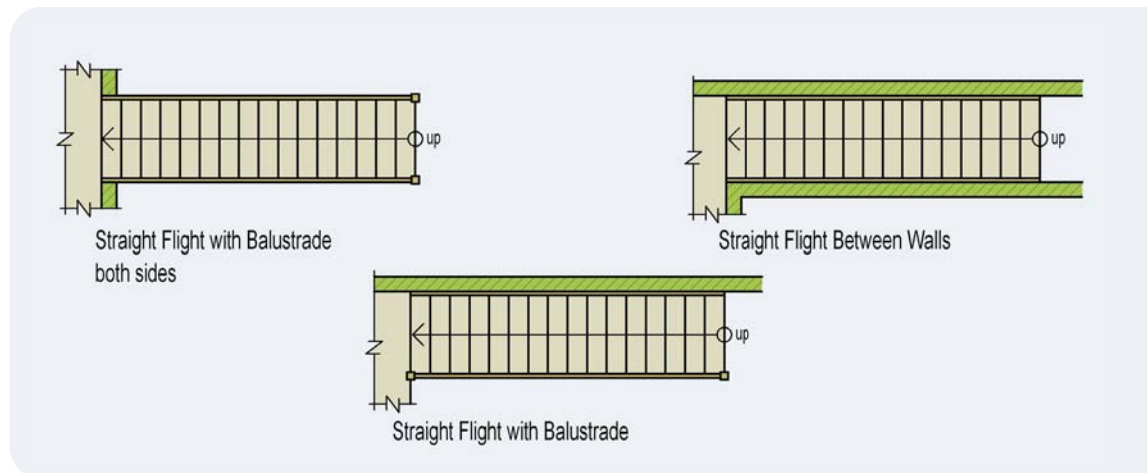


Figure 1.2: Straight stairs.

## 1.2 Straight Stairs with Intermediate Landing

Stairs having more than one flight rising in the same direction and all treads parallel (Figure 1.3).

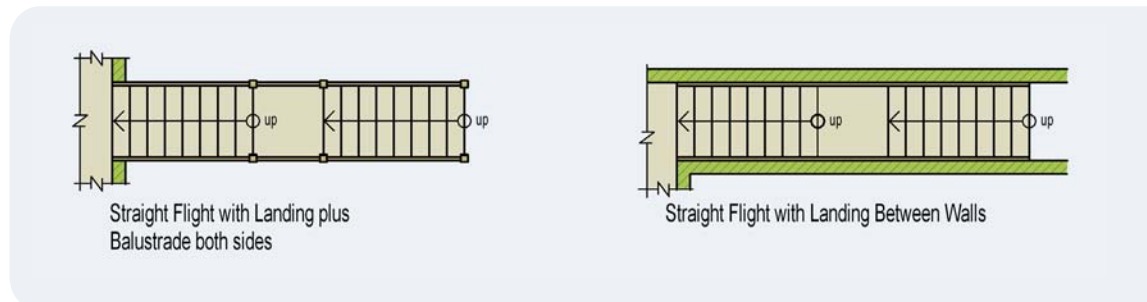


Figure 1.3: Straight stairs with landing.

## 1.3 Newel Stairs

All stairs which include newel posts in their construction are referred to as newel stairs. The newels support the handrails and/or balustrade and may also support the landings and strings. Figures 1.2 and 1.3 illustrate straight newel stairs. Figures 1.4, 1.5 and 1.6 show other forms of newel stairs.

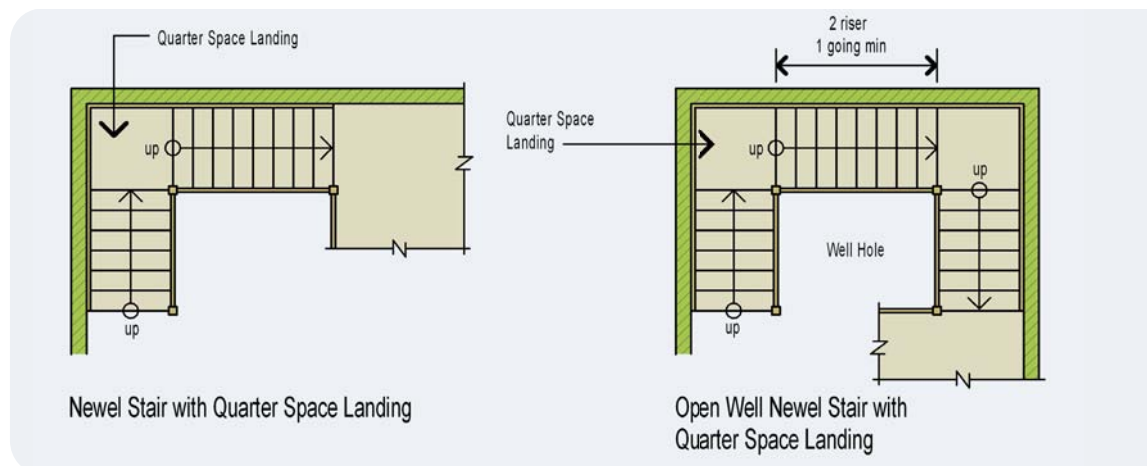


Figure 1.4: Newel stairs.

All stairs which include newel posts in their construction are referred to as newel stairs.

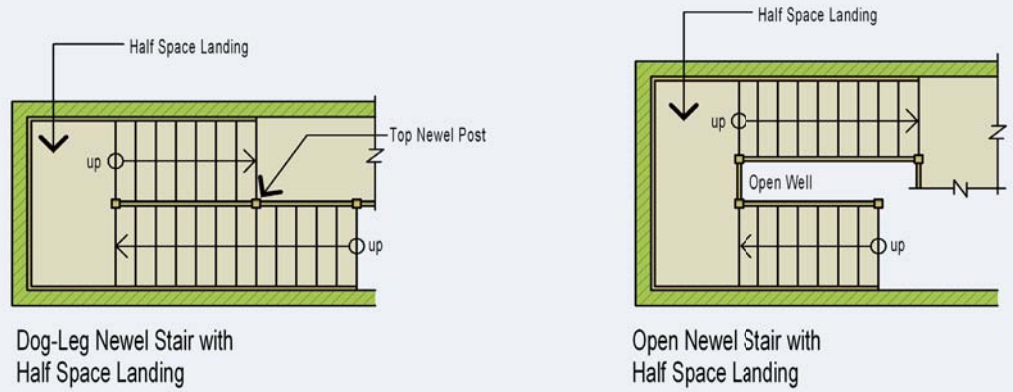


Figure 1.5: Dog-leg newel stairs.

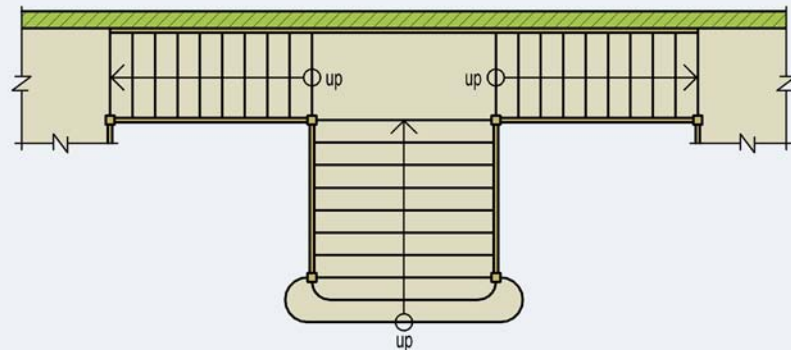


Figure 1.6: Newel stairs with wide landing.

#### 1.4 Open Newel Stair

An open newel stair is also referred to as an 'open well stair' or an 'open well newel stair'. This form of stair has two or more flights which return on each other forming a vertical space called the well (Figures 1.4 and 1.5).

#### 1.5 Dog-leg Stair

A newel stair having two flights built at 180° to each other from a half-space landing. The outer string of the upper flight is tenoned plumb above the outer string of the lower flight and both to a single common newel (Figure 1.5). This type of stair is not commonly used in housing.

#### 1.6 Winders

Triangular shaped treads used to gain height and in place of a quarter-space landing in a 90° turn stair. A maximum of three winders are fitted per 90° and the centre one is named a 'kite' winder because of its shape (Figure 1.7).

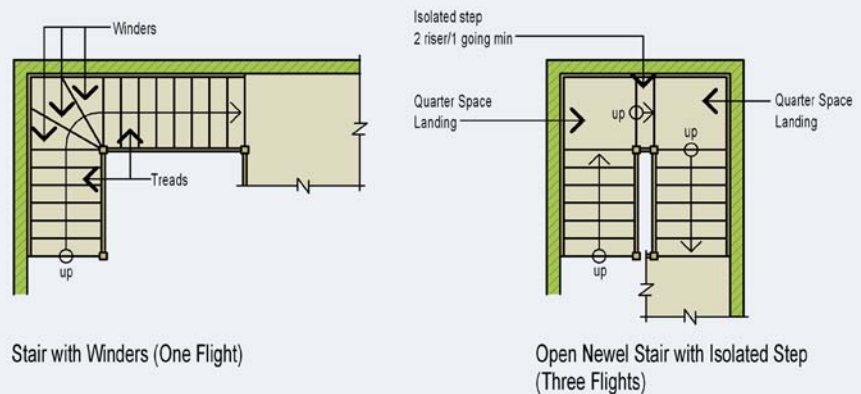
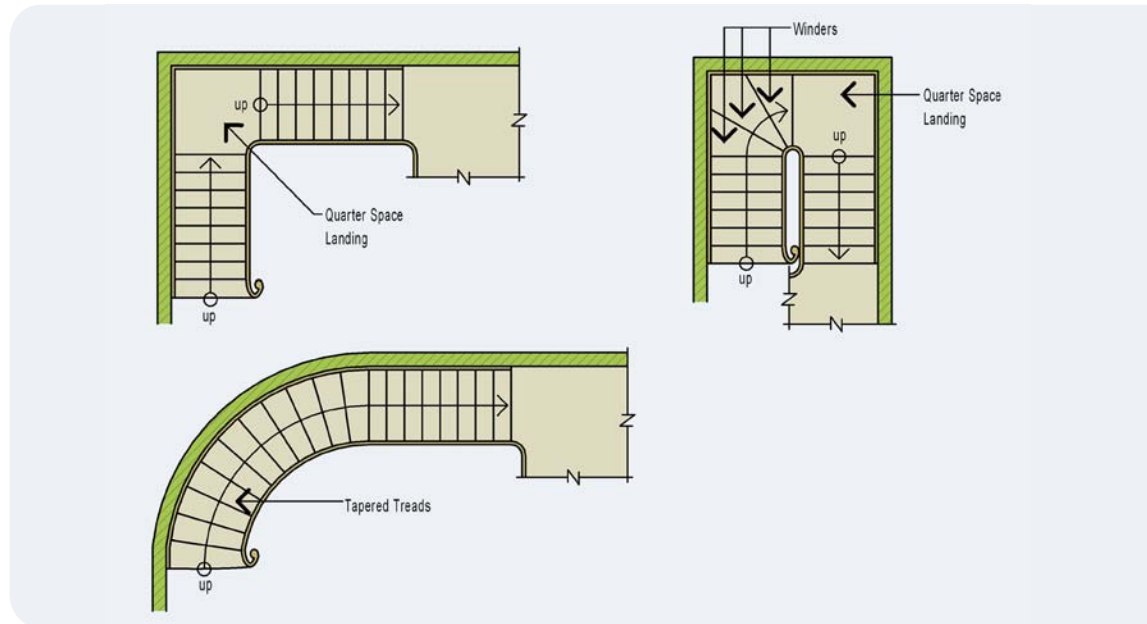


Figure 1.7: Stairs with winders or isolated step.



## 1.7 Geometrical Stairs

A stair which changes direction in plan without using newels. The strings and handrails are continuous from floor to floor, the curved portions being either cut from solid timber (saw kerfed), staved or laminated (Figure 1.8).



**Figure 1.8: Geometrical stairs.**

# 2

*Stairs, handrails and balustrades must be designed and constructed to comply with the loadings given in AS 1170 Part 1.*

*The BCA does not prescribe a minimum width for stairs.*

## BCA Requirements

The regulatory requirements for stairs and balustrades prescribed by the BCA are primarily concerned with addressing the safety issues associated with slips, trips and falls. The basic BCA requirements relating to stair and balustrade geometry, opening width, landing sizes, handrail heights, etc, need to be strictly followed to ensure regulatory compliance.

### 2.1 General

For all Classes of buildings, stairs, handrails and balustrades are required to comply with the Building Code of Australia (BCA). The BCA requirements include design and construction provisions for the various components including compliance with the loading provisions of AS 1170.1 'Structural design actions Part 1: Permanent, imposed and other actions'.

For stairs, handrails and balustrades, the BCA is primarily concerned with the safety of building users and occupants. Design and construction must therefore take into consideration both the strength and durability of materials and components as well as the 'geometric' constraints prescribed by the BCA. The following provides a brief summary of some of the BCA requirements. For full details refer to the BCA.

### 2.2 Stairs

A summary of the requirements of the BCA for straight flights of stairs is given below.

Each flight must have not more than 18 nor less than 2 risers.

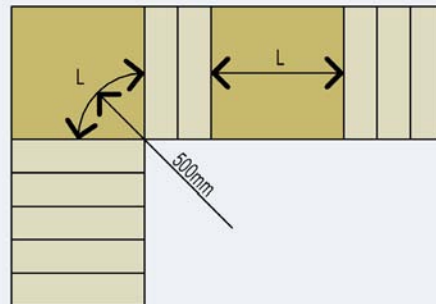
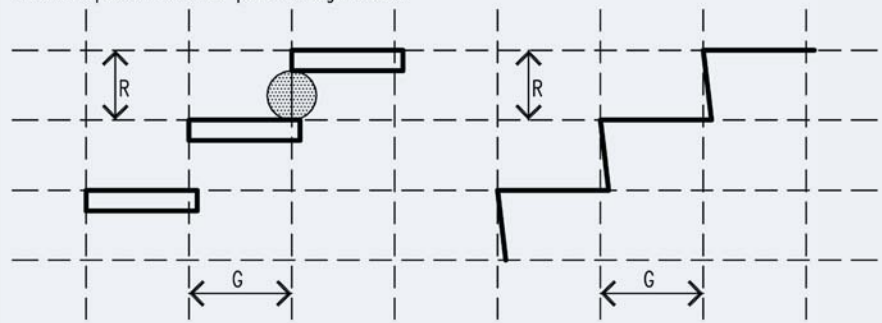
- The nominal dimension of goings and risers of a stair must be constant throughout each stair flight.
- The riser opening must not allow a 125 mm sphere to pass through between the treads.
- The going (G), riser (R) and slope relationship quantity ( $2R+G$ ) must be in accordance with Table 2.1.
- Landings must be not less than 750 mm long and where this involves a change in direction, the length is measured 500 mm from the inside edge of the landing (Appendix Figure A1).
- Landings must be provided where the sill of a threshold of a doorway opens on to a stair that provides a change in floor level or floor to ground level greater than 3 risers or 570 mm (Figure 2.2).

Note: The BCA does not prescribe a minimum width for stairs.

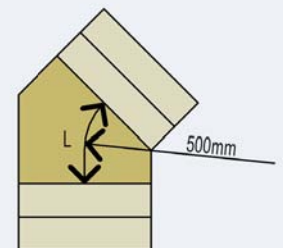
**Table 2.1: Riser and going dimensions.**

Stair Riser and Going Dimensions (mm)						
Stair Type	Riser(R) Going (G) (see following Figure)				Slope Relationship (2R+G)	
	Max	Min	Max	Min	Max	Min
Stairs (other than spiral)	190	115	355	240	700	550
Spiral	220	140	370	210	680	590

125mm sphere must not pass through treads.

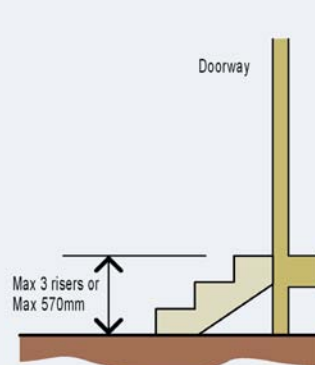


(i) Example A

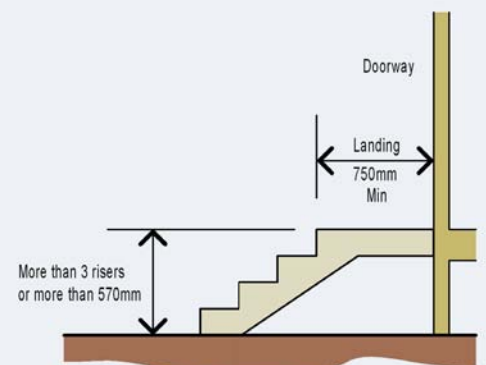


(ii) Example B

**Figure 2.1: Landing length.**



(i) Landing not required



(ii) Landing required

**Figure 2.2: Threshold landings.**

### 2.3 Balustrades and Handrails

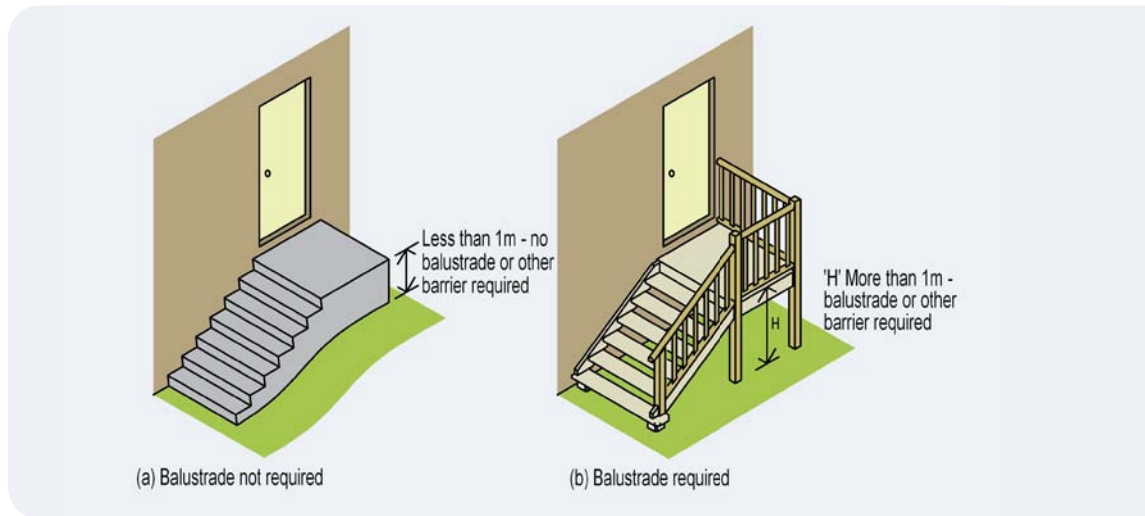
A continuous balustrade or other barrier must be provided along the side of any roof to which public access is provided, any stairway or ramp, any floor, corridor, hallway, balcony, verandah, mezzanine, access bridge or the like and along the side of any path of access to a building, if it is not bounded by a wall; and any level is more than 1 m above the surface beneath (Figure 2.3).

The height of a balustrade or other barrier must be not less than 1 m above the floor of any access path, balcony, landing, etc, and not be less than 865 mm above the nosings of the stair treads or the floor of a ramp (Figure 2.4).

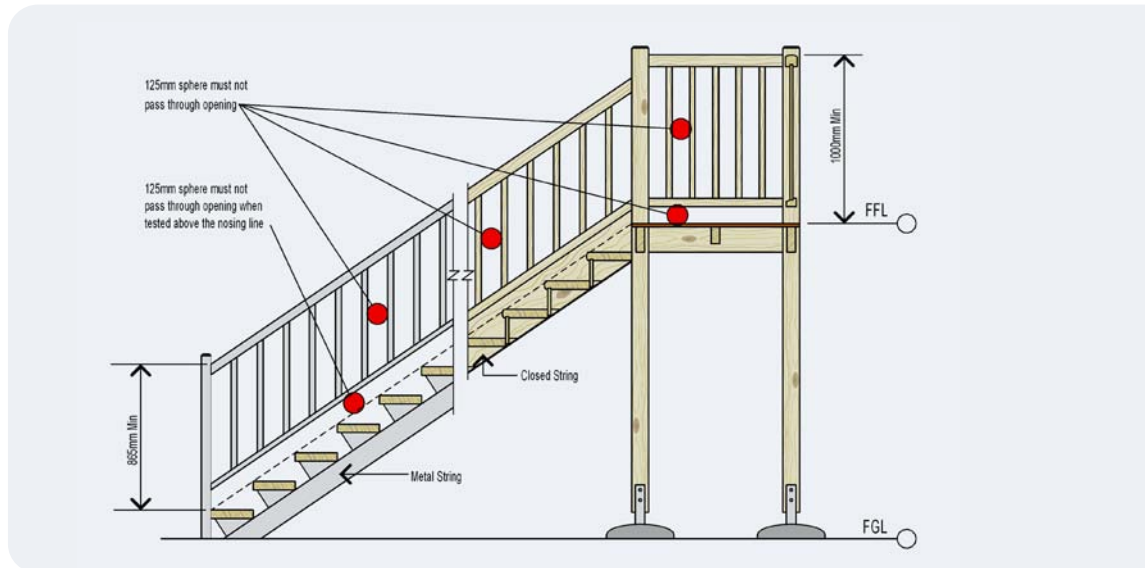
**Balustrades and handrails are required when stairs are not bounded by a wall and any level is more than 1 m above the surface beneath.**

Openings in balustrades (including decorative balustrades) or other barriers must be constructed so that any opening does not permit a 125 mm sphere to pass through it and for stairs, the space is tested above the nosing line (Figure 2.4).

For floors more than 4 m above the surface beneath, any horizontal elements within the balustrade or other barrier between 150 mm and 760 mm above the floor must not facilitate climbing.



**Figure 2.3: Balustrades – when required.**



**Figure 2.4: Minimum handrail height.**



# 3

## Materials for External Stairs Without Riser Boards (Open Stairs)

**The construction of stairs is very demanding and requires a high level of workmanship and accuracy. Open tread stairs are recommended for external use since housed risers will trap moisture and prevent good drainage and drying out. Housed treads can also trap moisture so pre-priming before assembly is highly recommended. As per the BCA requirements, the rise and going must be uniform throughout the flight, however for external stairs the bottom rise may vary slightly.**

### 3.1 Timber Durability and Species

In weather-exposed, above-ground applications or where subjected to other sources of moisture, stringers, treads, risers, handrails, posts, newels, balusters, and infill should be:

- (i) *Warm, humid tropical northern climates*: either Above Ground Durability Class 1 species with any sapwood present treated to H3 (or higher) or H3 (or higher) treated softwood such as Slash, Hoop or Radiata Pine. Preservative treatment to comply with AS 1604.
- (ii) *Temperate, cool southern climates*: either Above Ground Durability Class 2 or better species with any sapwood present treated to H3 (or higher) or H3 (or higher) treated softwood such as Slash, Hoop or Radiata Pine. Preservative treatment shall comply with AS 1604. Lower durability species can also be utilised although careful detailing of joints with application and maintenance of protective coatings (paints, stains) and/or installation of protective shielding (e.g. malthoid) on top of exposed timber edges needs to be utilised.

Suitable species are given in Table 3.1.

Note:

1. Meranti, Victorian Ash, Tasmanian Oak and Douglas Fir are not suitable for weather exposed structural applications.
2. For harsh climates timber with a sawn upper face provides greater long term weathering ability than a dressed surface. Step treads exposed to the weather should therefore be sawn all round or sized on two edges and one face (underside) only.
3. In Queensland, timber species used in structural applications including stairs and balustrades shall comply with 'Constructions Timbers in Queensland' as referenced by the Building Code of Australia.

**Table 3.1: Suitable species.**

Species	Availability	Posts in ground contact	Posts not in ground, stringers, treads, landing framing and decking
<b>Above Ground Durability Class 1</b>			
<b>Preservative Treated Pine (Caribbean Hoop, Radiata, Slash)</b>	All states	✓ H5 Treatment	✓ H3 Treatment
<b>Mixed Open Forest Hardwoods (Qld, Nth NSW)</b>	Qld, NSW	See Note 1	✓
<b>Blackbutt</b>	Qld, NSW	See Note 1	✓
<b>Cypress</b>	All eastern states	Sapwood Free	✓
<b>Gum Forest Red</b>	Qld	✓	✓
<b>Gum Grey</b>	Qld, NSW	✓	✓
<b>Gum River Red</b>	Vic, NSW	See Note 1	✓
<b>Gum Spotted</b>	Qld, NSW, Vic	See Note 1	✓
<b>Ironbark Red or Grey</b>	Qld, NSW, Vic	✓	✓
<b>Jarrah</b>	WA, SA, Vic	See Note 1	✓
<b>Kwila (Merbau)</b>	All states		✓
<b>Mahogany Red</b>	Qld, NSW	See Note 1	✓
<b>Mahogany White</b>	Qld, NSW	✓	✓
<b>Messmate Gympie</b>	Qld, NSW	✓	✓
<b>Tallowwood</b>	Qld, NSW	✓	✓
<b>Turpentine</b>	Qld, NSW	✓	✓
<b>Above Ground Durability Class 2</b>			
<b>Ash Silvertop</b>	Vic, NSW		✓
<b>Gum Southern Blue</b>	Vic, NSW		✓
<b>Gum Sydney Blue</b>	Vic, NSW		✓
<b>Gum Mountain Grey</b>	Vic, NSW		✓
<b>Jarrah</b>	WA, SA, Vic	See Note 1	✓
<b>Kapur</b>	All states		✓
<b>Karri</b>	WA, SA, Vic		✓
<b>Mahogany Southern</b>	Vic, NSW		✓
<b>Stringybark Blue-Leaved</b>	NSW		✓
<b>Stringybark Yellow</b>	Vic, NSW		✓

Notes:

1. These timbers should only be used for in-ground applications if they can be easily replaced if degrade occurs.
2. In Queensland, timber species used in structural applications including stairs, balustrades and handrails shall comply with 'Constructions Timbers in Queensland' as referenced by the Building Code of Australia.

Ensure timbers used for external stair construction have the required durability.

*Structural members should be free of any major strength reducing features.*

*Allowance should therefore be made for shrinkage in unseasoned stringers, treads and any associated newel posts, landing bearers and joists, etc.*

*Except in severe environments, hot dipped galvanised fasteners will afford the necessary protection from corrosion.*

### 3.2 Timber Grade

As stair stringers, treads and posts, etc, are structural members, they are required to be stress graded and should be free from any major strength-reducing features. In addition, timber for stair construction should also be straight grained and free from any imperfections that may detract from durability or serviceability performance requirements. Stringers, treads and posts should be in accordance with the following table.

**Table 3.2: Timber grade.**

Species	Australian Standard	Grade
Hardwood	AS 2082	Structural Grade 1, Appearance grade
Softwood (Caribbean, Radiata, Slash and imported softwood)	AS 2858	Structural Grade 1, Appearance grade
Hoop Pine	AS 2858	F8 Appearance grade
Cypress Pine	AS 2858	F7 Appearance grade

*Note: In addition, finger-jointed timber shall comply with AS 5068 – Timber – ‘Finger joints in structural products’ and laminated timber shall comply with AS 1328 – ‘Glued laminated structural timber’.*

### 3.3 Moisture Content

Traditionally, timber used for external stair construction is unseasoned. Depending on location and species, the amount of shrinkage occurring in unseasoned timber will vary. Generally, about 6% shrinkage (6 mm per 100 mm) should be expected for unseasoned open forest hardwoods. Allowance should therefore be made for shrinkage in unseasoned stringers, treads and any associated newel posts, landing bearers and joists, etc, and for the gaps that will develop between joints such as between stringer housings and treads.

External stair timbers exposed to the weather will reach Equilibrium Moisture Content (EMC) with their surroundings after a period of 9-18 months, depending upon prevailing weather, size and type of timber used.

For coastal Australia, stairs that are well ventilated should reach an EMC of approximately 16%. For stairs close to and over water, EMCs will normally be a little higher (18-21%) and for dry inland areas considerably lower (10-12%).

Note: If seasoned timber is used for external stairs coastal areas, consideration must be given to the expansion of the timber as the EMC rises from 12% up to about 16%, particularly at joints – such as where treads are housed into stringers – and may cause splitting.

### 3.4 Joint Priming

One coat of a water-repellent preservative or an oil-based primer is recommended to be applied to joints and housings, etc, prior to fabrication.

### 3.5 Corrosion Protection of Fasteners

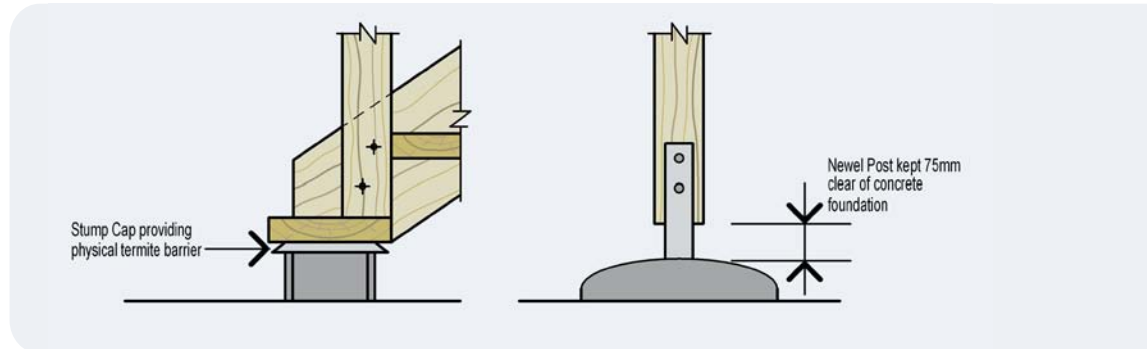
Having ensured that the maximum service life will be achieved in the timber component, it is equally important to match this with nails, screws, bolts and other metal connectors of equivalent service life. For most situations (up to and including close proximity to protected bays/mild marine) in exposed environments, hot dipped galvanised fasteners will afford the necessary protection from corrosion. The service life of hot dipped galvanised coatings will be proportional to their mass/area or thickness of galvanising and a minimum thickness of 42 microns is recommended for a service life of around 30 years. For more extreme corrosive environments or where other conditions dictate such as in contact with moist CCA/ACQ, etc, treated timber or in close proximity to swimming pools (within 600 mm of edge), guidance can be obtained from Table 3.3.

**Table 3.3: Selecting corrosive resistant fasteners.**

Application/Environment	Fastener Material	Remarks
<b>Chemical, industrial and marine surf beach or large bays</b>	Grade 316 stainless steel	Grade 304 stainless steel may require additional protective coatings such as epoxy paints.
<b>Splash zone close to pools</b>	Monel metal, silicon bronze and brass. Self drilling screws to be Class 4 finish.	Monel nails and screws available, usually used for boat building, are a good option close to pools. Silica bronze nails are good for acidic species such as western red cedar.
<b>Mild marine, industrial and other</b>	Hot dipped galvanised or mechanically plated, minimum thickness 42 microns. Self drilling screws to Class 3 finish.	Where hot dipped galvanised bolts, etc, are in contact with moist CCA/ACQ, etc, treated timber, additional protection using plastic sheaths, bituminous or epoxy paints is required.

### 3.6 Termite Protection

Physical and/or chemical barriers must be provided to protect the stairs and to ensure termites do not bypass protection systems to adjacent structures. Termite barriers must be designed so that they can be readily inspected and maintained.



**Figure 3.1: Typical termite protection methods.**





### 3.7 Slip Resistance

The BCA requires stair treads to have a slip resistant finish or an anti-skid strip near the nose of the tread. A number of proprietary 'paints' and 'strips' are available to satisfy this requirement.

### 3.8 Sizes

The sizes and spans for stringers and treads for external stairs shall be in accordance with Table 3.4 and 3.5.

**Table 3.4: Stair stringers (maximum stair width 1800 mm).**

Timber Type		Stringer – [Depth (mm) x Thickness (mm)] <sup>(1)</sup>				
Species/Group	Grade <sup>(2)</sup>	200x38	200x50	250x38	250x50	300x50
		Maximum Stringer Span (mm) <sup>(4)</sup>				
<b>Messmate, Spotted Gum, Blackbutt, Kwila, etc</b>	F27	2900	3200	3600	3900	4500
<b>Vic Ash, Tas Oak, Jarrah</b>	F22	2800	3100	3400	3700	4300
<b>Spotted Gum, Blackbutt, Ironbark, Kwila, etc</b>	F17 <sup>(3)</sup>	2600	3000	3300	3600	4200
<b>Douglas Fir (Nth American)</b>	F11	2400	2700	3000	3400	3900
<b>Radiata, Hoop, Slash, etc</b>	F8	2300	2600	2900	3200	3700
<b>H3 treated pine</b>	F5	1600	2200	2400	2800	3400

Notes:

1. The size of stringers given in the Table are nominal sizes. Design allowances have been made for dressing (depth 10 mm max, thickness 5 mm max). Allowance has also been made for trenching stringers to accommodate treads (10 mm max).
2. Timber grading should be in accordance with the appropriate Australian Standard for milled products (i.e. AS 2796 and AS 4785). The stress grades used for design in accordance with the loading requirements of the BCA are as indicated and can be determined for AS 2082 and AS 2858 as appropriate.
3. The F17 grade included in the Table is intended for unseasoned hardwood, to be used for external stairs only.
4. Stringer span is the centre line length of the stringer.

**Table 3.5: Stair treads (with open flights).**

Timber Type		Stair Width [Tread span] (mm)				
Species/Group	Grade <sup>(2)</sup>	750	1000	1200	1500	1800
		Minimum Thickness of Tread (mm) <sup>(1)</sup>				
<b>Messmate, Spotted Gum, Blackbutt, Kwila, etc</b>	F27	26	32	38	48	58
<b>Vic Ash, Tas Oak, Jarrah</b>	F22	28	34	40	50	60
<b>Spotted Gum, Kwila, Ironbark, etc</b>	F17 <sup>(3)</sup>	28	36	42	53	65
<b>Douglas Fir (Nth American)</b>	F11	31	40	46	58	70
<b>Radiata, Hoop, Slash, etc</b>	F8	32	42	50	62	73
<b>H3 treated pine</b>	F5	40	46	54	70	N/A

Notes:

1. The thicknesses in the Table are minimum design thicknesses and may not represent commercially available thicknesses.
2. Timber grading should be in accordance with the appropriate Australian Standard for milled products (ie AS 2796 and AS 4785). The stress grades used for design in accordance with the loading requirements of the BCA are as indicated and can be determined for AS 2082 and AS 2858 as appropriate.
3. The F17 grade included in the Table is intended for unseasoned hardwood, to be used for external stairs only.

Stringer span is the centre line length of the stringer

# 4

## Materials for Internal Stairs – With and Without Riser Boards (Open and Closed Stairs)

Interior staircase work is considered to be a specialised section of carpentry and joinery. Flights are often prepared in a workshop making full use of available machines and equipment. Interior stairs differ considerably in design, from simple straight flights, commonly used in domestic work, to more elaborate stairs constructed purposely as an attractive feature in public and commercial buildings and in elegant homes.

Many interior stairs are built from joinery quality timber cut and seasoned specially for stairs. The specified finish is often clear polish/polyurethane, etc, therefore both material and workmanship should be of the very highest standard.

### 4.1 Timber Durability and Species

For internal use, timber of any durability class is suitable, however hardness may need to be considered for uncovered treads.

The species chosen will generally determine the overall colour of the stairs. As a guide, Table 4.1 indicates the range of colours that may be expected. The sapwood of many hardwoods can be much lighter than adjacent heartwood and some treads, risers, strings, etc, may contain both light and dark colours.

Lyctid susceptible sapwood of some hardwood species e.g. Spotted Gum is required by some state legislation, including Queensland and New South Wales, to be preservative treated. Some treatments may impart a brown or green-grey tinge to sapwood, while boron preservative is non-colouring. LOSP treatment is also used. In this instance a H3 treatment may be used in lieu of H2 treatment to avoid the colour from dyes often used with H2 LOSP treatments.

Hardness indicates a species resistance to indentation and abrasion. Damage to timber stairs may occur due to heavy foot traffic and in particular 'stiletto-heel' type loading. The selection of a hard timber species ensures improved resistance to indentation and abrasion. Soft timber species, if used for step treads, can be expected to indent.

*Hardness may need to be considered for uncovered treads.*

*The selection of a hard timber species ensures improved resistance to indentation and abrasion.*

**Table 4.1: Species guide.**

Species	Availability	Colour	Hardness
<b>Australian Hardwood</b>			
Blackbutt	Qld, NSW	golden yellow to pale brown	very hard
Brushbox	Qld, NSW	mid brown even colour	hard
Forest Red Gum	Qld, NSW	dark brown or dark red brown	very hard
Ironbark	Qld, NSW, Vic	dark brown or dark red brown	very hard
Jarrah	WA, SA, Vic	dark red brown	hard
Karri	WA, SA	rich reddish-browns to pale pinks	hard
Manna/Ribbon Gum	Vic	pale straw pinks	moderately hard
Messmate	Vic	pale yellow to pale brown	moderately hard
New England Blackbutt	Qld, NSW	straw to pale brown	very hard
Rose Gum	Qld, NSW	straw pink to light red	hard
Southern Blue Gum	NSW	pale brown with some pink	hard
Spotted Gum	Qld, NSW	brown, dark brown, light sapwood	very hard
Stringybark	Qld, NSW, Vic	yellow brown with pink tinge	hard
Sydney Blue Gum	Qld, NSW	pink to dark red	hard
Tallowood	Qld, NSW	pale straw to light brown	hard
Tasmanian Oak	All states	pale straw to light brown, pink	moderately hard
Victorian Ash	All states	pale straw to light brown, pink	moderately hard
<b>Imported Hardwood</b>			
Kwila / Merbau	All states	dark brown	hard
Northern Box	Qld, NSW	mid brown even colour	hard
<b>Softwoods</b>			
Cypress	All Eastern states	straw sapwood, dark brown heartwood	moderately hard
Hoop Pine (Araucaria)	All states	straw	soft
Radiata	All states	white to straw	soft

## 4.2 Timber Grade

As stair stringers, treads and posts, etc. are structural members, they are required to be stress graded and should be free from any major strength-reducing features. In addition, timber for stair construction should also be seasoned, straight grained and free from any imperfections that may detract from serviceability performance requirements. For internal stairs, stringers, treads and posts should be in accordance with AS 2796, AS 4785 and the following:

**Table 4.2: Timber Grade**

Type	Australian Standard	Grade
Hardwood	AS 2082	Structural Grade 1, seasoned, Appearance grade
Softwood (Caribbean, Radiata, Slash and imported softwood)	AS 2858	Structural Grade 1, seasoned, Appearance grade
Hoop Pine	AS 2858	F7 seasoned, Appearance grade
Cypress Pine	AS 2858	F7 seasoned, Appearance grade

*Note: In addition, finger jointed timber shall comply with AS 5068 – Timber – ‘Finger joints in structural products’ and laminated timber shall comply with AS 1328 – ‘Glued laminated structural timber’.*

*All components of internal stairs should be seasoned.*

*Unless the staircase is in a permanently controlled environment, the timber will always move in response to changing environmental conditions.*

*For feature stairs, 30 mm is suggested as a minimum thickness for all treads, irrespective of stair width.*



### 4.3 Moisture Content

Unless otherwise specified, all components of internal stairs should be seasoned. Seasoned timber is usually supplied at an average moisture content between 11% and 13%. Where conditions are drier or in air-conditioned buildings, moisture content of timber may vary from 7% to 12%. In these situations the timber may need to be acclimatised on-site prior to fabrication.

Timber is a natural product that responds to changes in weather conditions. During periods of high humidity timber will absorb moisture from the air causing it to swell or increase in size. Conversely, during drier times when humidities are low, timber will shrink, reducing in size. Unless the staircase is in a permanently controlled environment, the timber will always move in response to changing environmental conditions. Gaps between treads and housings, treads and riser boards, etc, can be expected as the timber accommodates seasonal changes. Additional shrinkage to that normally expected may also occur when a staircase is exposed to heat sources such as fireplaces or sunlight through large doors or windows.

A small amount of noise can be expected from most timber stairs when walked on. Noises can occur from movement of treads in housings, treads against a riser board or from treads, risers, etc, moving on nails.

### 4.4 Termite Protection

Because termite protection of the house is required under the BCA in areas where termites are present, there is no specific requirement for individual termite protection of internal stairs unless the only method of termite protection for the house is the use of termite resistant material. In this case, termite resistant timber should be also chosen for the stairs. Refer to AS 3660.1.

### 4.5 Slip Resistance

The BCA performance requirements state that stair treads or near the nosing shall be slip resistant. A number of proprietary 'paints' and 'strips' are available to satisfy this requirement.

### 4.6 Span Tables

The sizes and spans for stringers for internal stairs with and without riser boards shall be the same as for external stairs (Table 3.4).

Note: For internal stringers and treads, seasoned timber only should be used.

The size of treads for internal stairs without riser boards shall be the same as for external stairs (Table 3.5).

The size of treads for internal stairs fully supported by riser boards should be a minimum of 19 mm thick for stairs up to 1000 mm wide and 30 mm for 1000-1800 mm wide.

Note: For feature stairs, 30 mm is suggested as a minimum thickness for all treads irrespective of stair width.

# 5

## Stair Construction Procedure

Before commencing the mark out for stairs, the calculations for going and rise can be determined (see Appendix B). From these, make a margin template and pitch board or set up a steel square with clamps ready to mark out strings.

### 5.1 Margin Template and Pitch Board

#### 5.1.1 Pitch Board

Using a piece of plywood, masonite (such as ply or masonite bracing) or similar, mark out and cut a pitch board using the going and rise calculated (Figure 5.1).

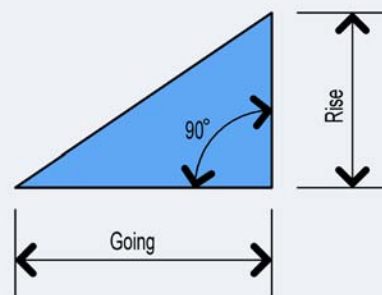


Figure 5.1: Pitch board.

#### 5.1.2 Margin Template

Before the margin template can be prepared, the width of the margin (X) must be known. The method of finding the margin width is as follows (Figure 5.2):

- Place the pitch board on the string, with the hypotenuse of the pitch board flush with the string edge.
- Use off-cut pieces of tread and riser board to draw into this trial position, the tread, and also riser and wedges if used.

Note: For stairs with riser boards, place the off-cut piece of tread upside down and align the front edge of the riser housing with the edge of the string as shown in Figure 5.2.

- Draw a line just below the tread (or wedges if used) and parallel to the string edge.
- The distance X is the width required for the margin template.

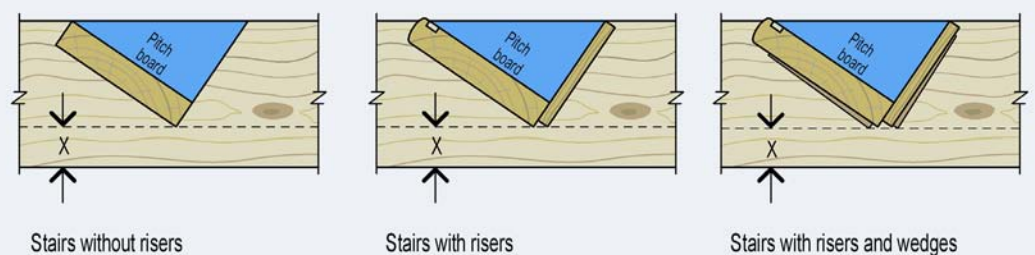
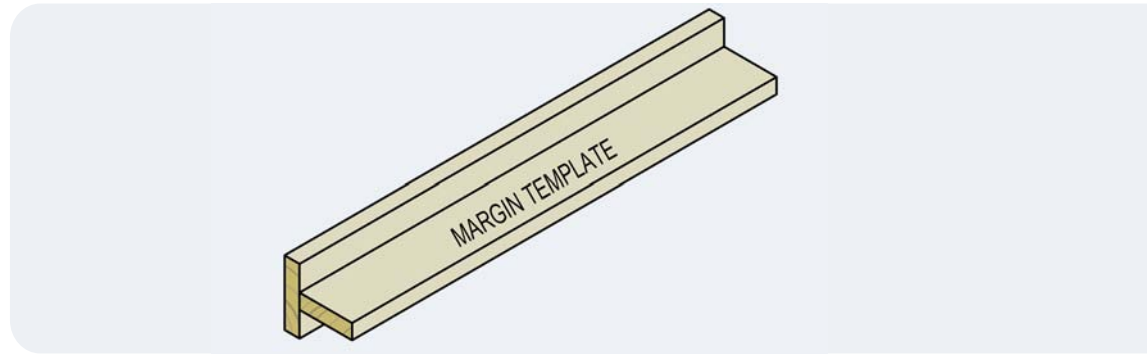


Figure 5.2: Determination of margin line.

A suitable margin template can now be constructed using off-cuts from mouldings (Figure 5.3).



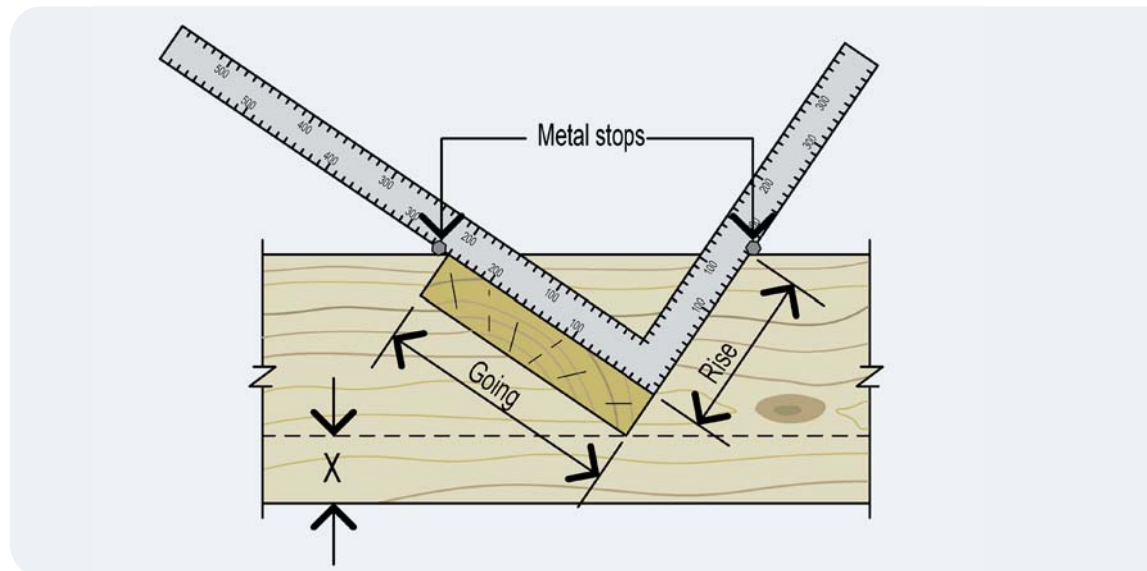
**Figure 5.3: Margin template.**

Note: This method may be followed to determine the width of timber required for strings.

### 5.1.3 Steel Square

Any large metal square such as a roofing square can be used as an alternative to a pitch board and margin template, but an understanding of the proceeding methods is necessary to be able to set the square up correctly.

Use the steel square and metal stops to find the margin line as per 5.1.2 and Figure 5.4.



**Figure 5.4: Using steel square to determine margin line.**



Reset metal stops on steel square incorporating margin line (Figure 5.5).

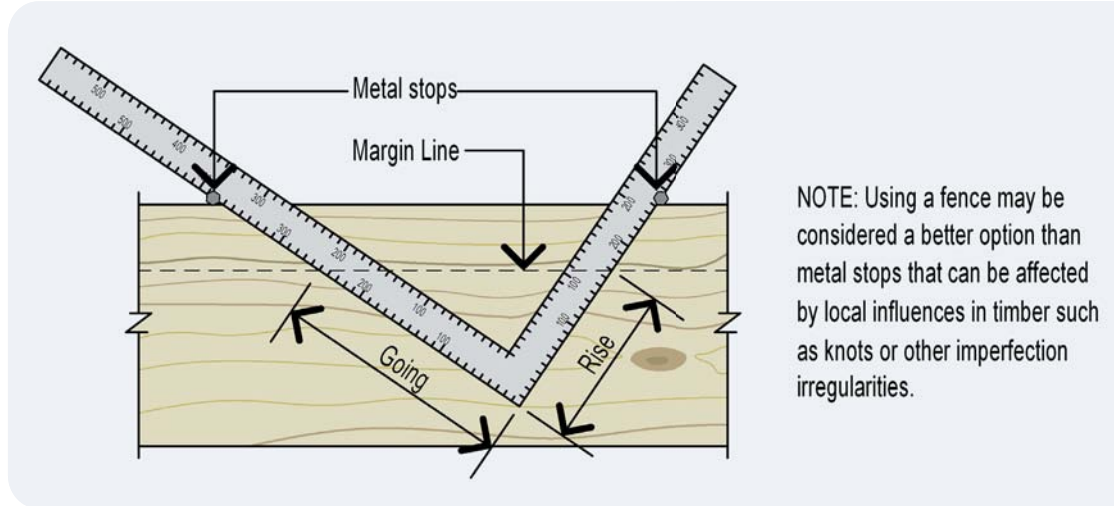


Figure 5.5: Using steel square as combined margin template and pitch board.

## 5.2 Marking Out Strings

*A good practice is to always mark out the same hand string first.*

When marking out stair strings a routine will prevent mistakes and the wasting of time. A good practice is to always mark out the same hand string first.

This practice should develop a clearer recognition of the correct positioning of members.

Note: The accepted practice of marking right hand or left hand string first varies from state to state and region to region. **The procedure below is based upon marking the left hand string first.**

### Step 1

The string handing is determined by looking up the flight or at the flight from the bottom. The string to the left is the left-hand string. The two strings in one flight are a pair; one left and one right-hand string.

### Step 2

Place strings in pairs on saw tools and mark inside face and top edges – consider the effect of any spring or bow. For short flights with one step bolt, place the hollow of the bow in and for longer flights with two step bolts place the hollow of the bow out. String edges should be rounded up (spring up) (Figure 5.6).

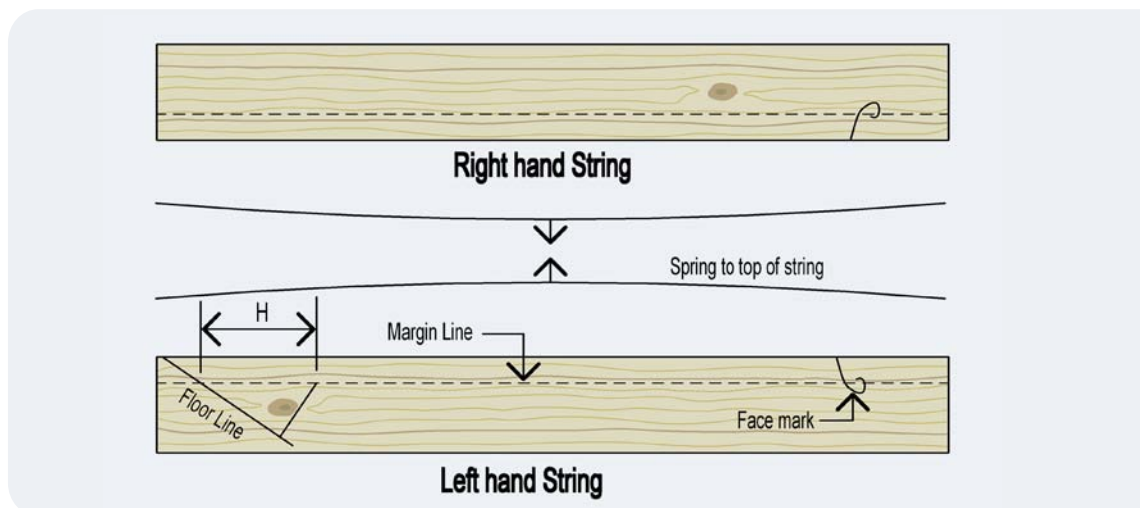


Figure 5.6: Pairing strings.

### Step 3

Having paired the strings by face and edge marking them, commence marking out the left-hand string. Draw the margin line with the margin template, then using the pitch board, start at the bottom of the flight and mark the position of the floor, the first rise and going (Figure 5.6).

Before continuing to mark the string, a pair of wing dividers set to distance 'H' in Figure 5.6 should be used to mark along the margin line, the number of remaining steps in the flight. This action will serve to equalise successive marking with the pitch board and avoid possible loss or gain.

### Step 4

After completing the marking of the first string, place both strings together as a pair and square the points on the margin line across from one to the other. This method will prevent length differences between the two strings (Figure 5.7 and Figure 5.8).

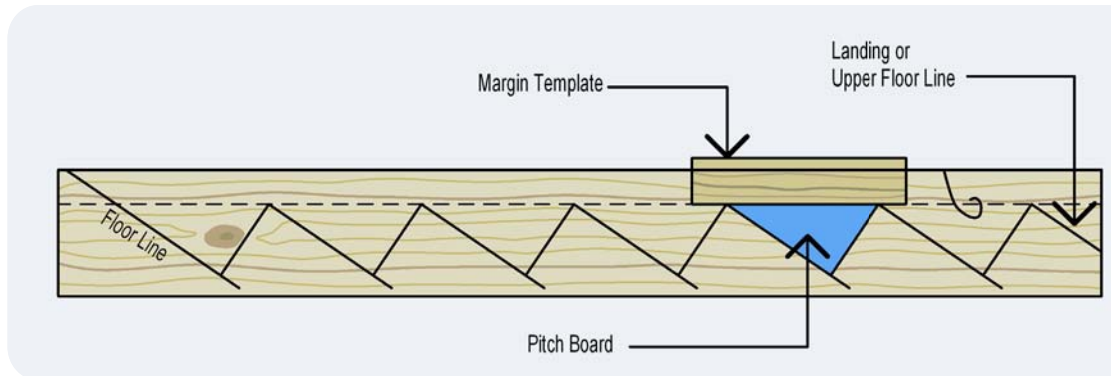
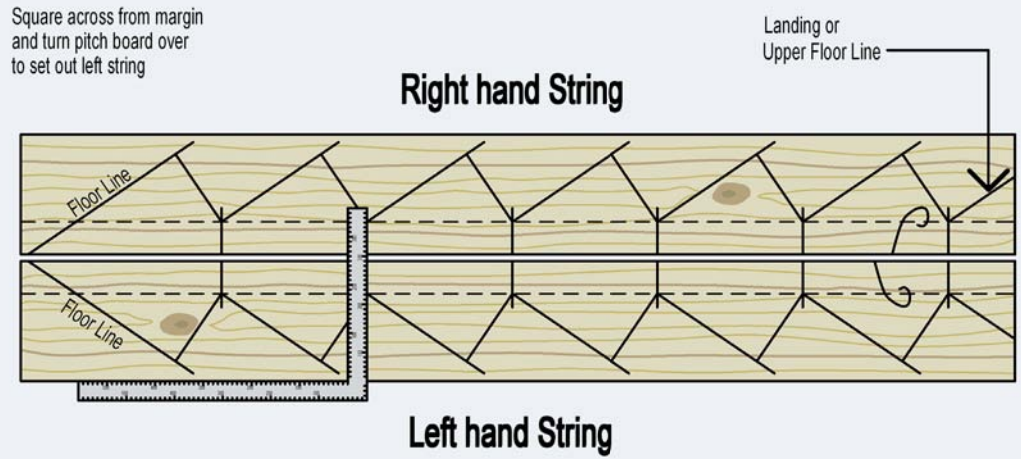


Figure 5.7: Marking out left string.





*Gauge depth = tread thickness minus housing depth.*

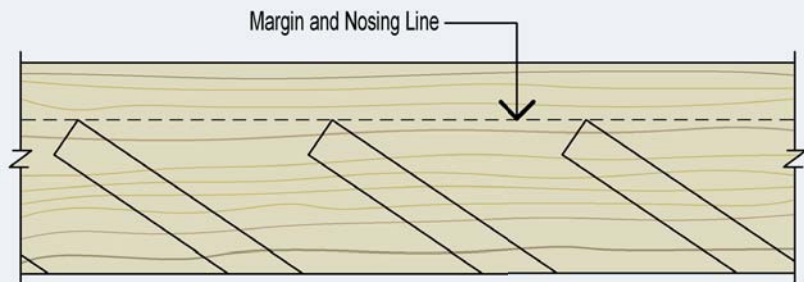


**Figure 5.8: Marking out right string.**

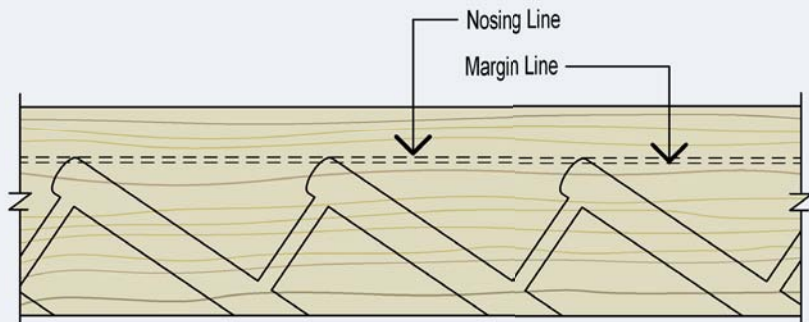
**Step 5**

When satisfied that the initial marking, as in Figure 5.8, is correct, proceed to complete the marking for the housings. Number each tread and riser. Select treads and risers (if used) in numerical order and scribe thickness and shape onto strings. Using a gauge, mark the housing depth (15 mm) onto the back edge of the string. Always gauge from the outside of the tread. This will account for any differences in thickness of the tread particularly when using unseasoned rough sawn timber.

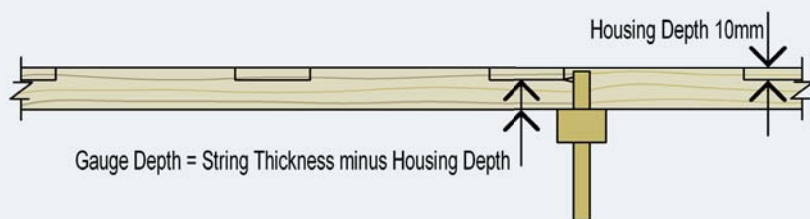
Note: Gauge depth = tread thickness minus housing depth (Figure 5.9).



Treads marked onto string for an open stair



Treads marked onto string for a closed flight



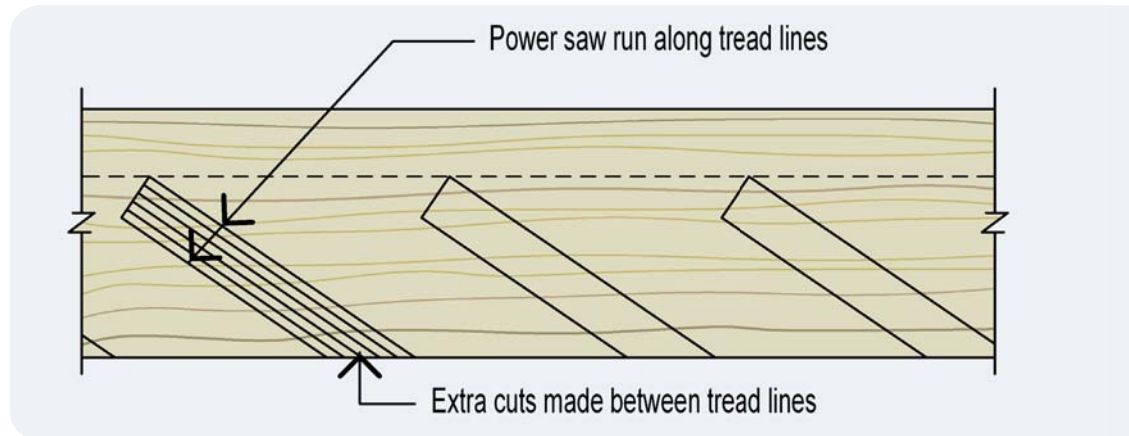
**Figure 5.9: String marked out for housings.**

### 5.3 Housing Strings

The actual housing out of the strings can be achieved by several different methods.

The simplest method, suitable for external stairs using rough sawn timber, is to use a power saw to cut along the lines marked for the treads.

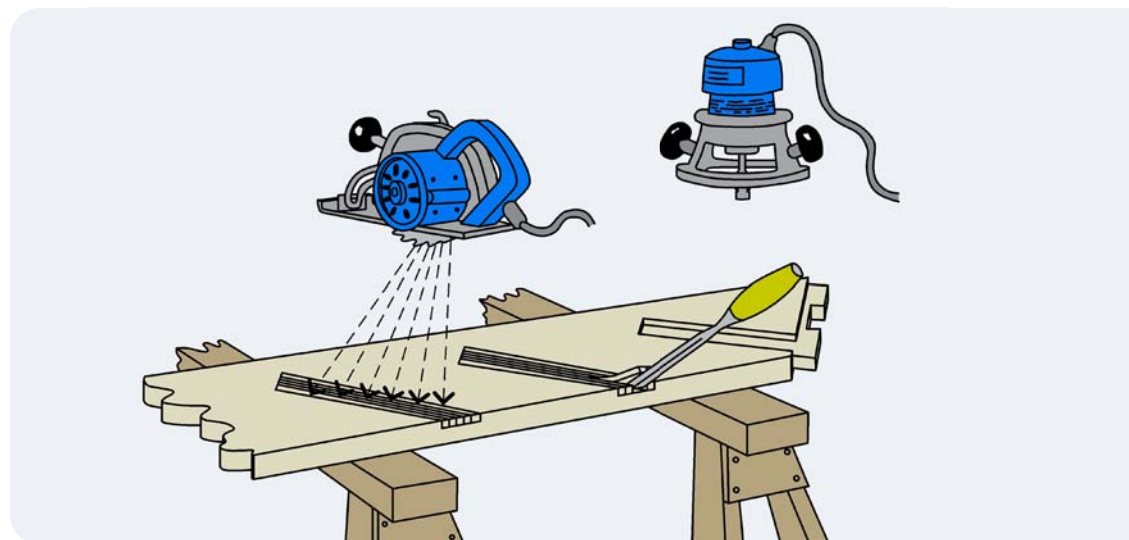
Set the depth of the saw to the housing depth, 15 mm. Run the saw a number of times between these cuts and then use a mallet/hammer and chisel to remove the remaining material (Figures 5.10 and 5.11).



**Figure 5.10: Housing strings.**



A router with a template guide fitted can be used and is possibly the best and neatest method for housing strings on site (Figure 5.11).



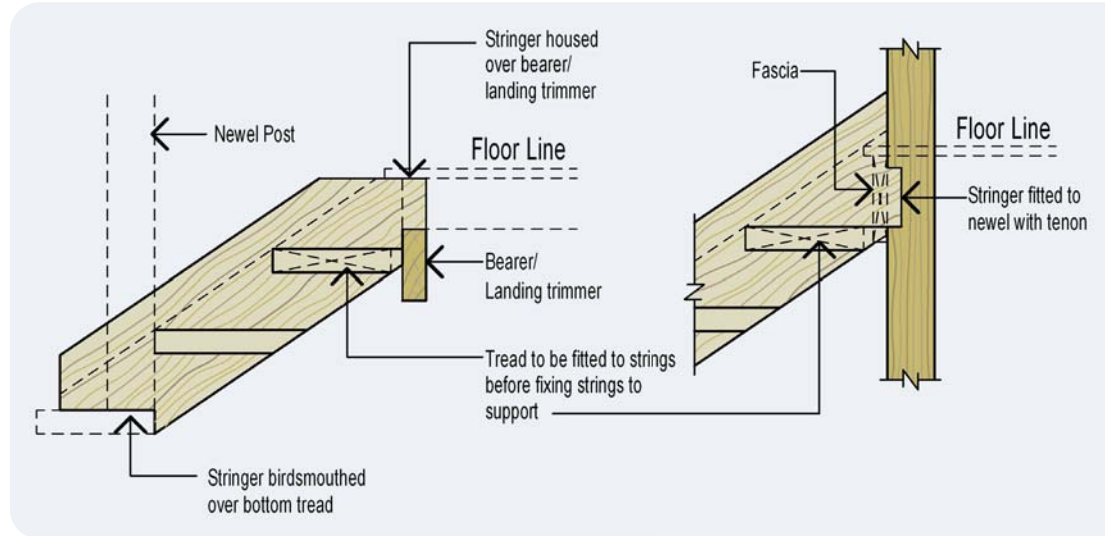
**Figure 5.11: Housing string practices.**

## 5.4 String End Joints

*The joint used will depend on the type of stair and the structure it is being attached to.*

The marking for the appropriate joints at the ends of the strings can now also be completed.

The joint used will depend on the type of stair and the structure to which it is being attached. For example, for a simple external flight the string is generally notched over the bearer (or landing plate) or tenoned into a newel post at the top and birdsmouthed over the bottom tread (Figure 5.12).

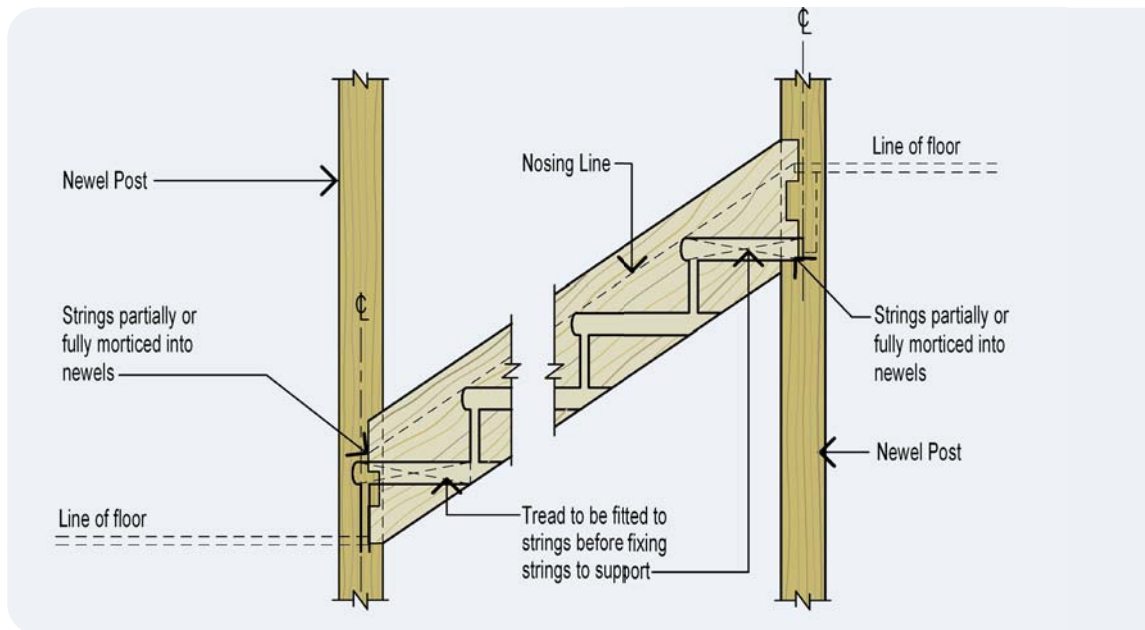


**Figure 5.12: Supporting stringers.**



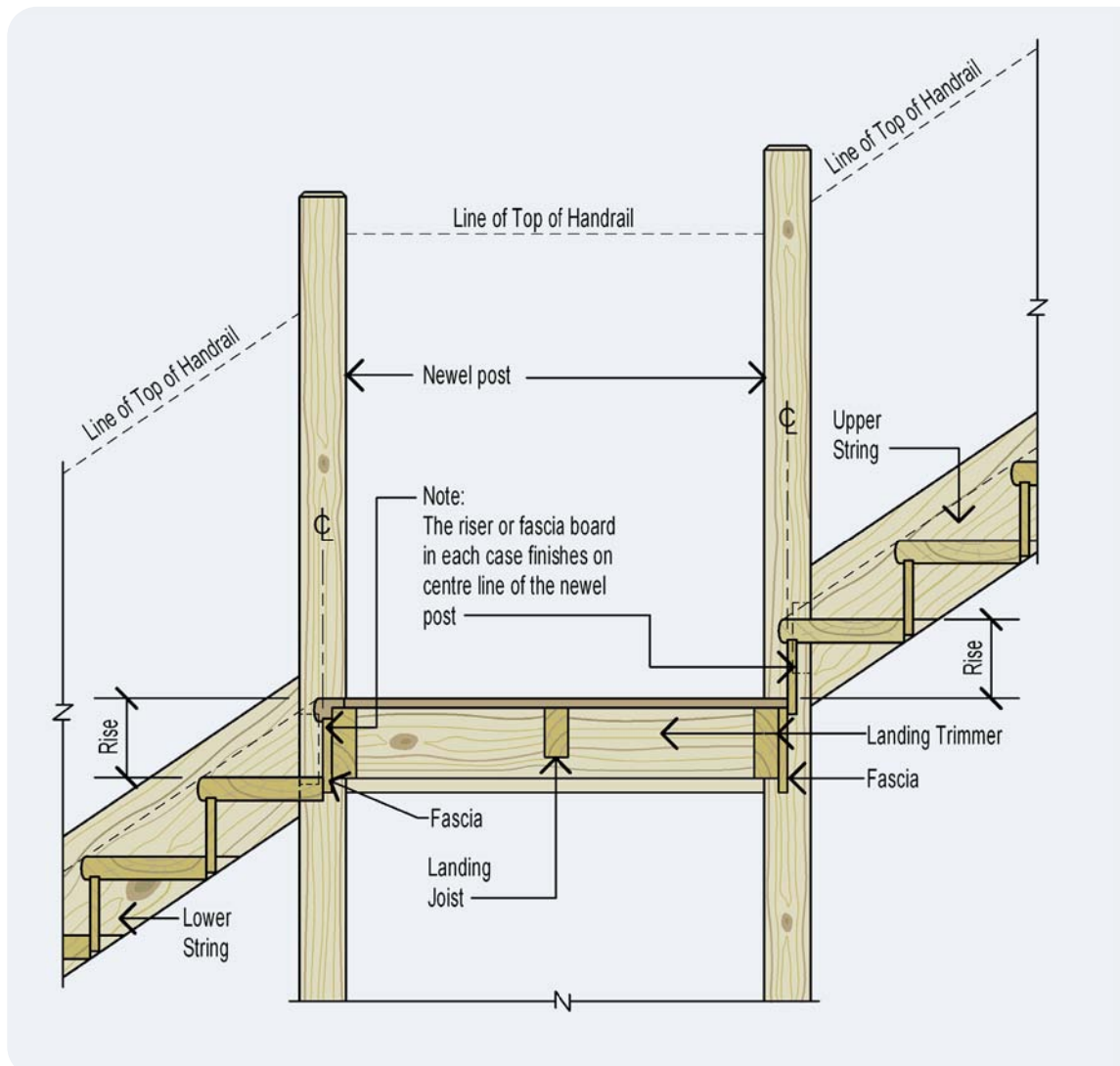
Where newel posts are used, tenons are cut on the end of the strings and the newels morticed to suit (Figures 5.13 and 5.14).

*Stringers lift and separate!*



**Figure 5.13: Tenons at ends of stringer.**

In some cases (usually internal stairs only) the faces of the first and last risers should be in the centre of the newel posts.



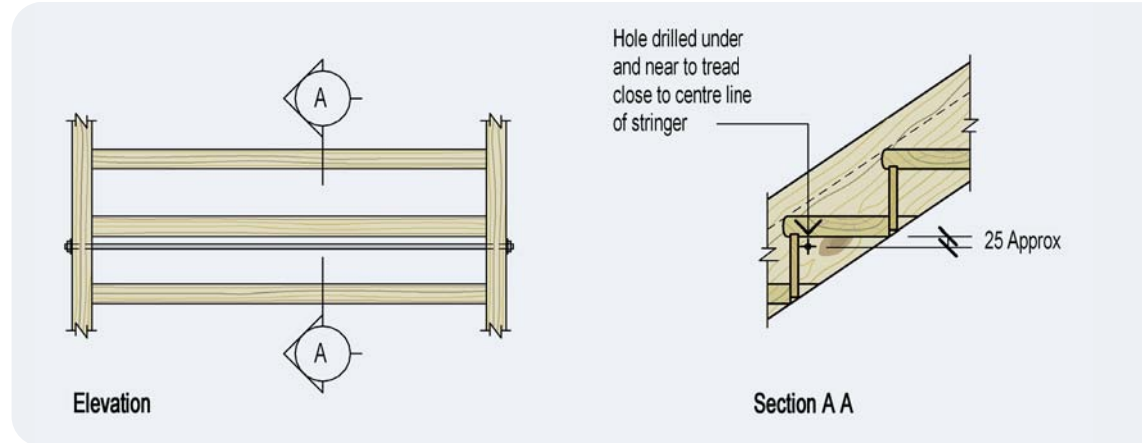
**Figure 5.14: Fixing strings to landing newels.**

*Unless the stairs fit between two walls, step bolts will be needed.*

Cut treads and risers to length and number from bottom to top – make allowance for extra length on bottom tread if specified – remove arrises (edges) as required. If risers are being used and the treads are not pre-grooved, groove the treads for risers.

### 5.5 Step Bolts (Tie Bolts)

Unless the stairs fit between two walls, step bolts will be needed. Bore the stringers to take 12 mm step bolts at a maximum of 1350 mm centres. Position them to coincide as closely as possible to the centre line of the stringer and underside of a tread, leaving a gap between the underside of the tread and the bolt (Figure 5.15).



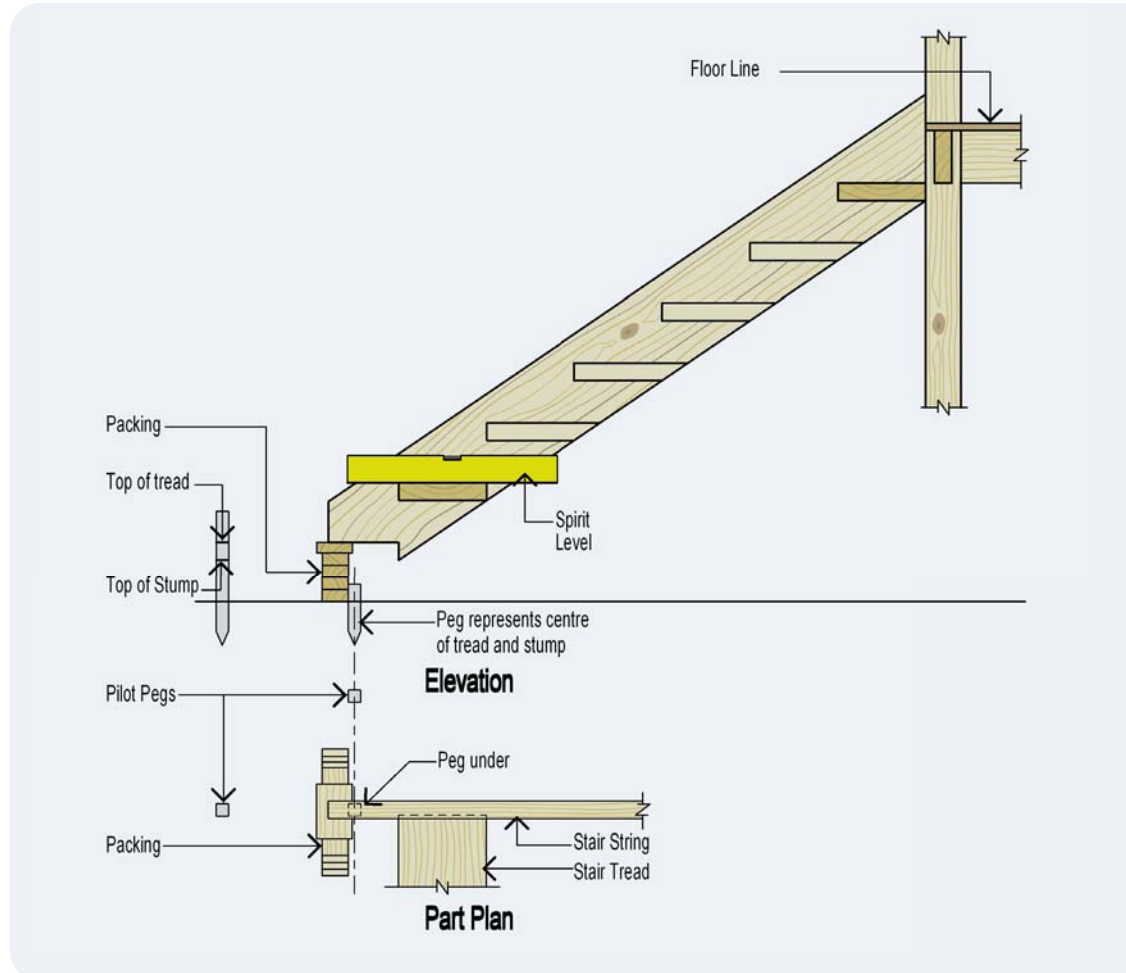
**Figure 5.15: Position of step bolt.**



## 5.6 Assembly

Before starting to assemble external stairs, prime paint or oil all joints and surfaces that will be concealed, enclosed or unable to be painted after assembly including the newels, bearer or joist where the stairs are to be fixed.

A practical way to find the position of the stumps under the bottom tread – rather than by calculation – is to take one of the cut strings, place it in position and then level the tread housings with a spirit level (Figure 5.16). Make any adjustments necessary by packing under the lower end of the string. Use pilot pegs to locate the centre and top of the stumps as shown in Figure 5.16.



**Figure 5.16: Finding position of stumps.**

Fit top and bottom (or second bottom) treads and, for flights with risers, the bottom riser only to strings and nail together. Nail together with three 100 x 4.5 mm nails per joint. Pre-drill if necessary. For external stairs, all nails used should be hot dipped galvanised.

Fit and loosely tighten step bolts if required.

Lift this partly assembled job into position fit the stringers to the newels, bearers or joists as required.

Fit the remainder of the treads and risers where used and nail with three nails per housing.

Tighten the step bolts.

Note: When using unseasoned timber it is good practice to temporarily nail treads and risers. After allowing as much time as possible for shrinkage to take place, withdraw the nails, close the joints then complete nailing and punching.

*When using unseasoned timber it is good practice to temporarily nail treads and risers. After allowing as much time as possible for shrinkage to take place, withdraw the nails, close the joints then complete nailing and punching.*

# 6

## Balustrades and Handrails

For all Classes of building, balustrades and handrails are required to comply with the Building Code of Australia (BCA). The BCA requirements include design and construction provisions for the various components including compliance with the loading provisions of AS 1170.1 'Structural design actions Part 1: Permanent, imposed and other actions'.

For balustrades and handrails, the BCA is primarily concerned with the safety of building users and occupants. Design and construction must therefore take into consideration both the strength and durability of materials and components as well as the 'geometric' constraints.

See Section 2 for guidance on BCA requirements, including those for where the floor surface is more than 4 m above the floor/ground below.



**Balustrades and railings must resist 0.9 kN inward, outward and downward load at any point.**

**Use Above Ground Durability Class 1 or H3 treated pine species for weather exposed applications.**

### 6.1 Loads

AS 1170.1 requires balustrades and railings together with members and connections which provide structural support to be able to resist the following factored limit state loads – 0.9 kN inward, outward and downward load at any point. It also requires balustrades and handrails to be able to resist a factored horizontal or vertical load of 0.53 kN/m for all areas within or servicing exclusively one dwelling including stairs and landings excluding external balconies, and 1.13 kN/m for external balconies in domestic and other residential buildings. Infill, including balusters, should be capable of resisting 0.75 kN in any direction.

### 6.2 Materials

#### 6.2.1 Durability

In **weather-exposed**, above-ground applications or where subjected to other sources of moisture, stringers, treads, risers, handrails, posts, newels, balusters and infill should be:

- (i) *Warm, humid tropical northern climates*: either Above Ground Durability Class 1 species with any sapwood present treated to H3 (or higher) or H3 (or higher) treated softwood such as Slash, Hoop or Radiata Pine. Preservative treatment shall comply with AS 1604.

(ii) *Temperate, cool southern climates*: either Above Ground Durability Class 2 or better species with any sapwood present treated to H3 (or higher) or H3 (or higher) treated softwood such as Slash, Hoop or Radiata Pine. Preservative treatment shall comply with AS 1604. Lower durability species can also be utilised although careful detailing of joints with application and maintenance of protective coatings (paints, stains) and/or installation of protective shielding (e.g. malthoid) on top of exposed timber edges needs to be utilised.

Suitable species are listed in Table 3.1.

Care should be taken to ensure that water is not trapped by end grain abutting horizontal surfaces (i.e. slope end grain cuts top and bottom of balusters and bottom rails where balusters abut, provide drainage holes, etc).

For **internal use**, timber of any durability class is suitable.

## 6.2.2 Timber Grade

The timber should be free from any major strength-reducing features, be straight grained and be in accordance with the following:

**Table 6.1: Timber grade.**

Type	Australian Standard	Description	Grade
<b>Hardwood (Including Meranti)</b>	AS 2796	Sawn and milled products	Clear or select grade
<b>Softwood (Including imported softwood)</b>	AS 1786	Joinery timber milled from Australian grown conifers	Clear grade

In addition, finger jointed timber shall comply with AS 5068 – Timber – ‘Finger joints in structural products’ and laminated timber shall comply with AS 1328 – ‘Glued laminated structural timber’.

*Notes:*

1. *Materials used in accordance with the following information must satisfy relevant Australian Standards and have the relevant minimum mechanical properties including the following:*

**Hardwood** – Stress Grade F22, (characteristic bending strength  $f'b = 65$  MPa, Modulus of elasticity  $E = 16,000$  MPa) and Joint Group JD2. Examples – Spotted Gum, Ironbark, Blackbutt, Kwila and Merbau.

**Meranti and Australian Softwood** – (characteristic bending strength  $f'b = 25$  MPa, Modulus of elasticity  $E = 9100$  MPa) and Joint Group JD4. Examples – Radiata, Hoop and Slash Pine and Meranti.

**Imported Softwood** – (characteristic bending strength  $f'b = 25$  MPa, Modulus of elasticity  $E = 6,900$  MPa) and Joint Group JD4. Examples – New Zealand Radiata Pine.

2. *Unless certified by the supplier to identify that it is ‘Australian Grown’ softwood, handrail (balustrades) spans shall be determined from the ‘Imported Softwood’ spans given in Table 6.2.*

## 6.3 Member Sizes

### 6.3.1 Handrails

Handrail sizes and spans shall be in accordance with Table 6.2.

### 6.3.2 Posts/Newel Posts

Posts and newel posts shall have a minimum stress grade of F5. Where supporting handrails/balustrades only, the minimum size of posts and newel posts shall be 80 x 80 mm (maximum post spacing 3600 mm and height of 2700 mm). Where supporting roof and or floor loads, refer to AS 1684 to determine minimum size, but shall be not less than 80 x 80 mm.

### 6.3.3 Infill/Balusters

The minimum size of infill/balusters should be as follows:

Hardwood – 19 x 19 mm or 21 mm diameter

Softwood – 19 x 42, 32 x 32 or 25 mm diameter.

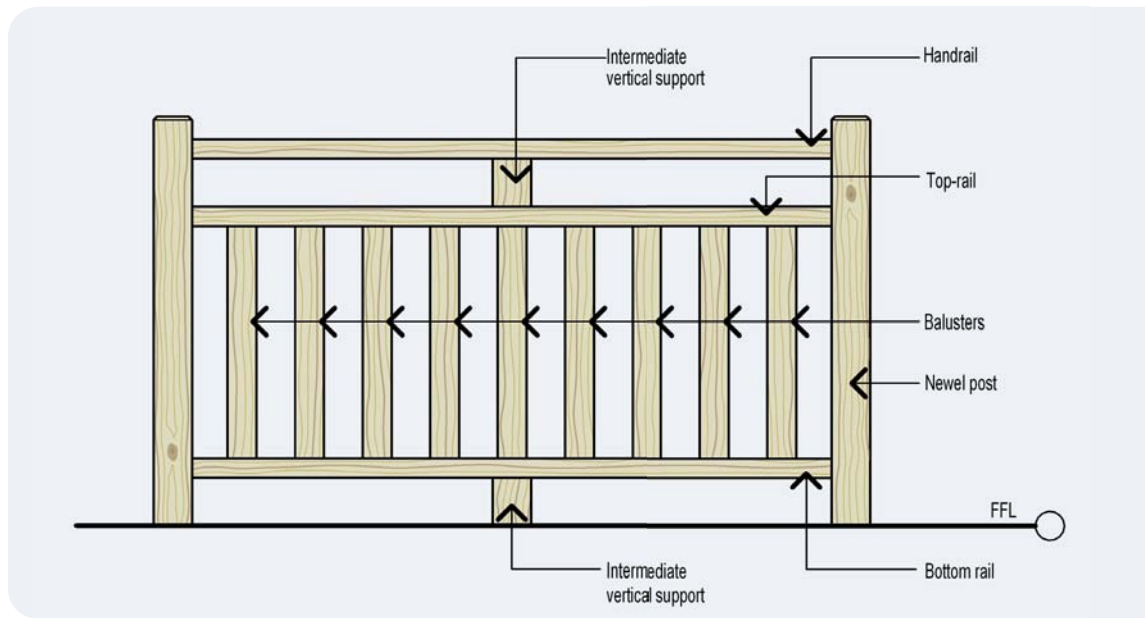


**Table 6.2: Handrail sizes.**

Timber	Size/Description (mm x mm)	Maximum span of Handrail (mm)			
		Within or exclusively servicing one Dwelling (excluding external balconies)		Other areas in Residential Buildings (including external balconies)	
<b>Hardwood</b>	65 x 65 (profiled)	3000	3000	3000	3000
	42 x 65 (profiled)	2200	2700	2200	2700
	42 x 85 (profiled)	2400	3400	2400	3400
	35 x 70	2100	3000	2100	3000
	35 x 90	2200	3600	2200	3600
	35 x 120	2400	3600	2400	3600
	45 x 70	2500	3200	2500	3200
	45 x 90	2700	3600	2700	3600
	45 x 120	2900	3600	2900	3600
	70 x 70	3500	3500	3500	3500
	70 x 90	3600	3600	3600	3600
<b>Meranti and Australian Grown Softwood</b>	65 x 65 (profiled)	2700	2700	2200	2200
	42 x 65 (profiled)	1400	2000	1400	1800
	42 x 85 (profiled)	1800	3000	1700	2400
	35 x 70	1200	2400	1200	2000
	35 x 90	1600	3200	1600	2500
	35 x 120	2100	3600	1800	3400
	45 x 70	2000	2800	1800	2200
	45 x 90	2400	3400	2000	2900
	45 x 120	2600	3600	2400	3600
	70 x 70	3200	3200	2800	2800
	70 x 90	3400	3600	3200	3600
<b>Softwood Imported or Unknown Origin</b>	65 x 65 (profiled)	2400	2400	2200	2200
	42 x 65 (profiled)	1400	2000	1400	1800
	42 x 85 (profiled)	1800	2700	1700	2400
	35 x 70	1200	2400	1200	2000
	35 x 90	1600	2900	1600	2500
	35 x 120	1900	3600	1800	3400
	45 x 70	2000	2600	1800	2200
	45 x 90	2200	3100	2000	2900
	45 x 120	2300	3600	2300	3600
	70 x 70	2900	2900	2800	2800
	70 x 90	3000	3400	3000	3400

**Notes:**

1. Handrails with no intermediate vertical supports may be used on flat or on edge (Figure 6.2).
2. Handrails with intermediate vertical supports shall be installed on flat with intermediate vertical supports spaced not greater than the allowable spans given for the same handrail with no intermediate vertical supports (Figure 6.2 and Note: For Type E connections refer to manufacturers' specifications).
3. Figure 6.4.
4. Where a top rail (minimum size 42 x 65) is within 150 mm of the main handrail and is rigidly fixed to it (using blocks, or balusters or dowels that pass through the mid rail and are fixed to the top rail) at least once at mid span, the allowable span of the handrail may be increased by 300 mm.
5. Handrail spans have been limited to 3600 mm maximum.
6. Profiled sections typically include bread loaf, ladies waist and colonial profiles.
7. There is no negative tolerance permitted on the breadth or depth dimensions (overall outside dimensions of profiled shapes) given in the above Table.



**Figure 6.1: Intermediate vertical support.**



**Figure 6.2: Handrails – on flat and on edge.**

## 6.4 Connections

### 6.4.1 Posts

Posts and newel posts should be connected to floor framing/stringers in accordance with Figure 6.3.

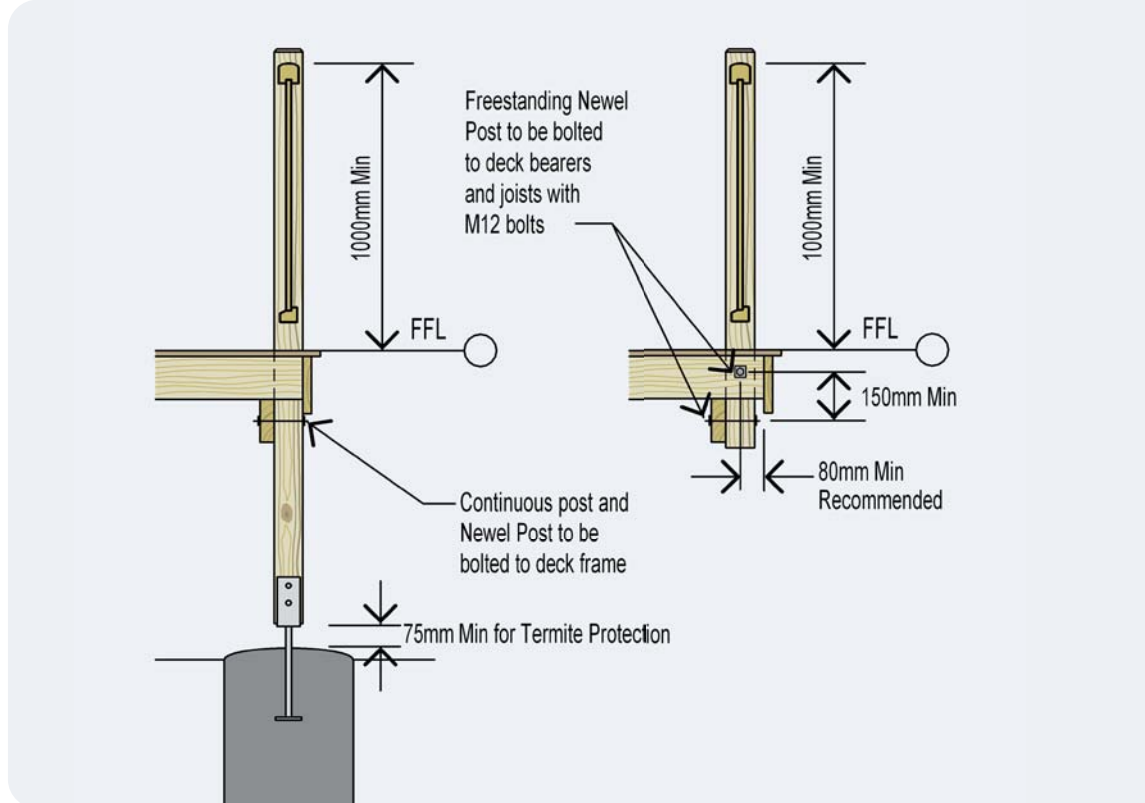


Figure 6.3 (a): Posts and newel posts.

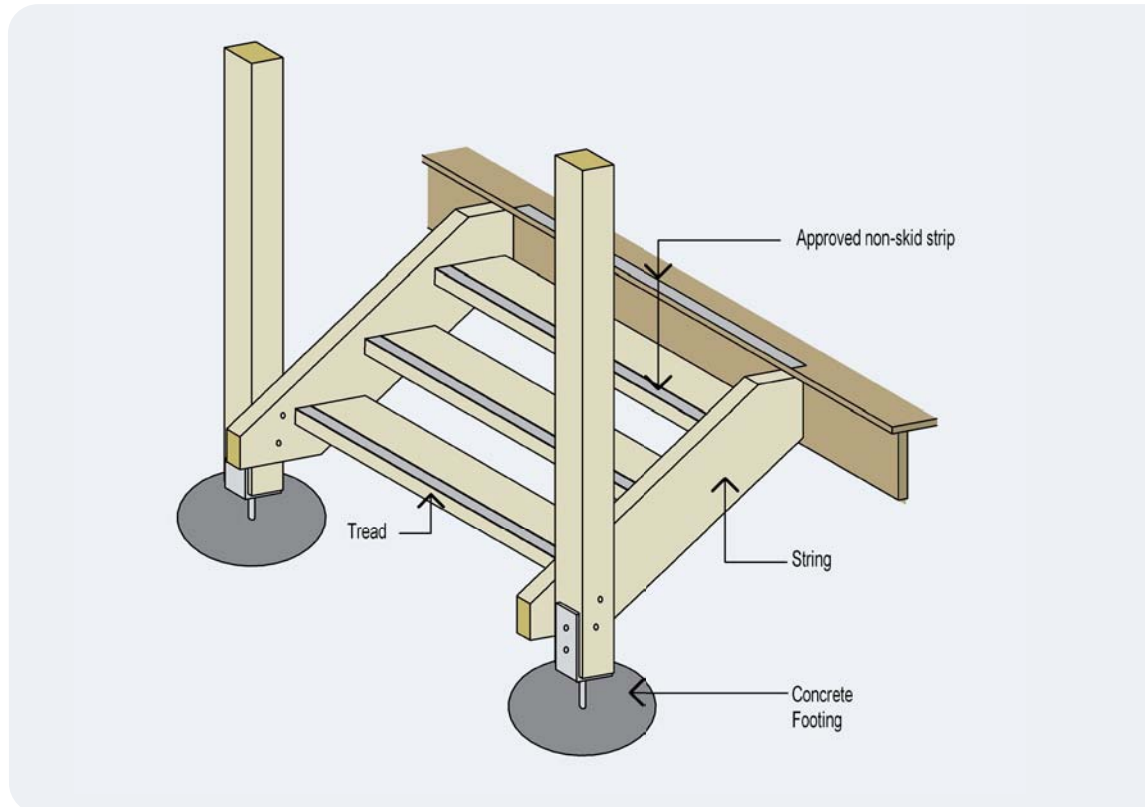


Figure 6.3(b)

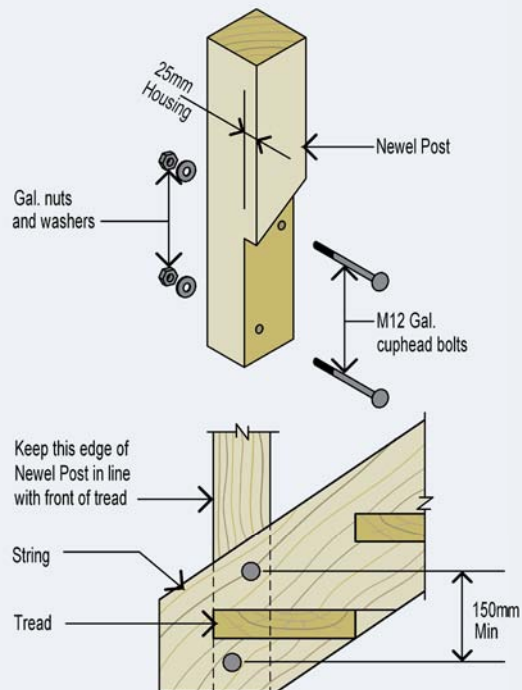


Figure 6.3(c)

### 6.4.2 Handrails

Table 6.3: Loads on handrails.

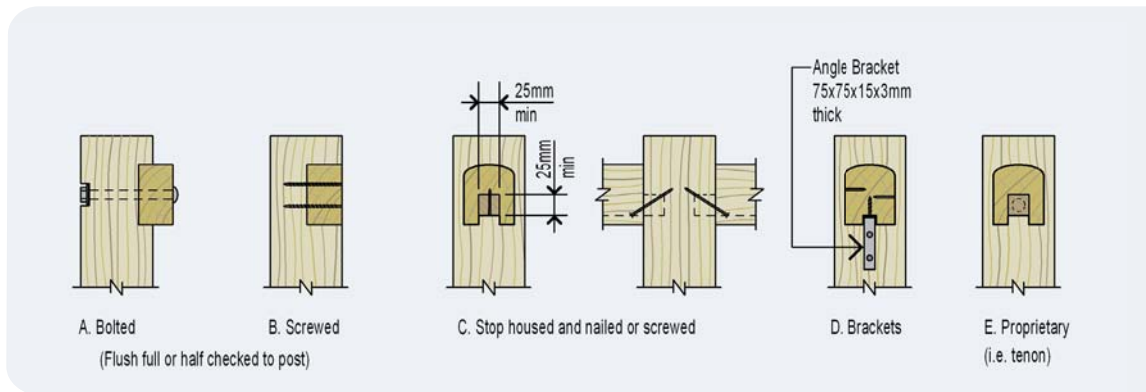
Span Type	Handrail Span (mm)	Handrail Connection Loads (kN)		Example Of Determining Handrail Connection
		Within or exclusively servicing one Dwelling (exc. external balconies)	Other Areas in Residential Buildings (inc. external balconies)	
Single Span	1800	0.90	1.0	<p>The shaded areas in Tables 6-3 and 6-4 provide a guide to the selection of an appropriate connection for a continuous span softwood handrail span of 2400 mm.</p> <p>Step 1. From Table 6-3 determine the load on the handrail = 2.7 kN</p> <p>Step 2 From Table 6.4 and Figure 6.4, determine a connection with the capacity to resist 2.7 kN.</p> <p>Step 3 Acceptable solutions determined from Table 6-4 are:-</p> <p>Type A connection, 1 M10 bolt or Type B connection, 2 No 10 screws or Type D connection, 2 No 10 screws per leg of bracket.</p>
	2100	0.90	1.2	
	2400	0.90	1.4	
	2700	0.90	1.5	
	3000	0.90	1.7	
	3300	0.99	1.9	
	3600	1.1	2.0	
Continuous Span	1800	1.1	2.0	
	2100	1.3	2.4	
	2400	1.4	2.7	
	2700	1.6	3.0	
	3000	1.8	3.4	
	3300	2.0	3.7	
	3600	2.2	4.1	

**Table 6.4: Capacity of handrail connections.**

Timber	Capacity of Connections (kN)											
	Type A			Type B			Type C				Type D	
	No. Bolts	Bolt Size (Cuphead)		No. Screws	Screw Size (Type 17)		Screws		Nails		2 / Screws per leg of bracket	
		M10	M12		No10	No14	2/ No10	2/ No14	2/3.15 dia	2/3.75 dia	No10	No14
<b>Hardwood (JD2)</b>	1	13	14	1	3.4	4.4	1.9	2.3	1.6	1.8	4.9	7.6
	2	26	28	2	6.8	8.8						
<b>Softwood and Meranti (JD4)</b>	1	8	9	1	2.0	2.6	1.1	1.3	0.9	1.0	2.8	4.3
	2	16	18	2	4.0	5.2						

**Notes:**

1. For Type A connections quantities are given for both face mounted handrails (worst case) and handrails flush full or half checked to post.
2. For Type B connections, minimum screw penetration into post is 38 mm and handrails flush full or half checked to post.
3. For Type C connections the minimum screw penetration into post is 40 mm and the minimum nail penetration into post is 38 mm.
4. Midrails and bottom rails shall be fixed with a minimum of 2/3.15 dia. skew nails.



**Figure 6.4: Handrail connections.**

*Note: For Type E connections refer to manufacturers' specifications.*

# 7

*Application and maintenance of finishes should not be considered as a substitute for ensuring that the inherent durability of the underlying timber is appropriate to the service life required.*

## Weathering, Finishes and Maintenance

**The long-term durability and visual appeal and aesthetics of both internal and external stairs and balustrades can be greatly enhanced by application and maintenance of suitable and appropriate finishes.**

### 7.1 External Stairs and Balustrades

Other than for aesthetic reasons, the main objective of applying and maintaining finishes (paints and stains) on timber used in external applications is to minimise the effects of weathering and therefore to maximise the service life of the timber. Exposure to sun and rain leads to wetting and drying and subsequent checking, splitting and distortion.

Application and maintenance of finishes should not be considered as a substitute for ensuring that the inherent durability (natural or by treatment) of the underlying timber is appropriate to the service life required for the applicable hazard level.

#### 7.1.1 Unprimed Timber

Nail holes should be stopped with an exterior grade wood filler. Dirt or any loose material should be removed prior to coating. All surfaces, ends and joints should be primed prior to assembly with a quality solvent-based alkyd primer or stain, in accordance with the manufacturers' recommendations.

Final top coats of exterior paint or stain should then be applied in accordance with the manufacturers' recommendations.

#### 7.1.2 Pre-primed LOSP Treated Timber

Pink pre-coated handrail and balustrade components should be sanded back and dusted off to remove any loose or powdery coatings prior to finishing. Nail holes should be stopped with an exterior grade wood filler.

All surfaces, ends and joints should be primed prior to assembly with a quality, solvent based alkyd primer. When the primer has dried in accordance with the manufacturers recommendations, apply two full coats of premium 100% acrylic exterior topcoat in accordance with manufacturers recommendations.

Dark coloured paints and stains should be avoided as they heat timber to elevated temperatures which cause greater loss of moisture and subsequent shrinkage and checking. Decay is also more active at higher temperatures.

### 7.2 Internal Stairs

The finish for interior stairs is often clear polish, lacquer, etc, therefore both material and workmanship should be of the very highest standard.

If clear finishes are to be used, extra care should be taken when marking out that pencil marks, etc, are kept light and do not leave an indentation in the timber.

Any nails should be punched a minimum of 3 mm below the surface of the boards. The punched nail holes can then be filled with either oil or non-oil based filler. Oil-based fillers may bleed oil into the timber and affect the colour of the wood surrounding the nail hole, or may not be compatible with various coating products.

The colour of the filler should be carefully selected to minimise any visual impact of the filler. Many of these products are sold in colours pre-matched to specific species. Generally all fillers are slightly darker and this allows for the boards to deepen in colour following finishing and UV exposure.

Generally all fillers are slightly darker and this allows for the boards to deepen in colour following finishing and UV exposure.

**Table 7.1: Clear finishes for stairs.**

Oil based Alkyds		Composite		Solvent based		Water based	
Tung oil	Linseed oil based varnishes	Oil modified Urethanes (OMU)	Urethane oil/alkyd 'Tung oil'	2 pack	Single pack	Polyurethane	
				Polyurethane	Polyurethane (moisture cured)	Acrylic	Single and two pack
Less wear resistant finish requiring more frequent maintenance				High wear resistant finish		Moderate to high wear resistant finishes	
6-24 hour drying by solvent evaporation				1-4 hour drying by chemical reaction		2-4 hour drying by evaporation and reaction	
Some tolerance to waxes				Not tolerant to waxes		Not tolerant to waxes	
Moderate to strong odour on application				Strong odour on application		Minimal odour on application	
Avoid inhalation and contact				Avoid inhalation and contact		Avoid inhaling cross-linkers and hardeners	
Matt to gloss levels				Matt to very high gloss levels		Matt to gloss levels	
Darkens with age				Darkens with age		Less darkening with age	
Generally ready for use 2-5 days from completion*				Generally ready for use 2-3 days from completion*		Generally ready for use 2 days from completion*	
*Varies with weather conditions and product. Full curing may take a longer time.							

# A

## Appendix A – Glossary

Refer to Figures A1 and A2 for illustrations of most terms.

### A1 General

**Stair, Stairs:** An assembly of steps or flights including all necessary landings, balustrades, etc, constructed for the easy, convenient and safe passage from one floor to another.

**Staircase:** Means the same as stair or stairs but includes that part of the building enclosing the stairs.

**Stairway:** Generally means the space provided for the stairs including the opening in the floor.

**Stairwell or well hole** (the opening in the upper floor for the stairs): The vertical space seen down between the outer strings of stairs having one or more return flights.

**Step:** A combination of a tread and riser. One unit in stairs.

**Flight:** That portion of stairs that has a continuous series of risers, including risers of winders, not interrupted by a landing or floor.

**Riser:** The height between consecutive treads (top of tread to top of next tread).

**Total rise** (Rise of flight, Rise of stair): The vertical measurement from the top of the first (lowest) floor or ground to the top of the last (highest) floor regardless of the number of flights in the stair.

**Going:** The horizontal dimension from the front to the back of a tread less any overhang from the next tread above (front of a riser line to front of the next riser line).

**Total going** (Going of flight, Going of stair): The horizontal distance measured in one direction over one or more flights, including intermediate landings, and taken from the front edge of the first or bottom tread in the lower flight to the front edge of the floor or landing at the top of the stairs. Again, if risers are fitted, the horizontal measurement from the face of the first or lowest riser to the face of the last or top riser in the stairs.

**Stair width:** The unobstructed width measurement between the inside face of the handrails, or the stringers if there are no handrails. (Note: The BCA does not prescribe a minimum width for stairs.)

### A2 Members in a Staircase

**String, stringers or string boards** (sides of the stair): The inclined members in a stair which usually act as a beam and which span from bottom to top of each flight and support the ends of the treads and risers.

**Treads:** The horizontal members in a flight on which the foot is placed when ascending or descending the flight.

**Step bolt (tie bolt):** A horizontal threaded rod commonly used to tie the stringers together in external open flight stairs.

**Riser boards:** The vertical boards fixed between successive treads. Their purpose is to close the openings between and help to support and stiffen the treads.

**Nosing:** The front edge of a tread that may or may not be projecting over the riser. It is usually rounded.

**Scotia:** A small moulding having a concave face. It may be fitted against the top face of the riser and under the nosing of some boxed stairs (rarely used these days).

**Newels:** The posts at the top and bottom of flights to which strings and balustrades are fixed. Newels may also support landings and form part of balustrades.

**Landing:** An area (floor or resting place) at the top or bottom of a flight or between two flights.



### A3 Members in a Balustrade

**Balustrade:** A coping or handrail with supporting balusters. An open balustrade comprises balusters, handrail, bottom rail or string capping. A solid balustrade may have panelling, glass or perspex instead of balusters.

**Balusters:** Vertical members which infill the space beneath and support the handrail.

**Handrail:** The support for the hands at the side of the stairs or landings/decks, etc.

**Bottom rail (string):** The lowest horizontal member in a balustrade that supports the balusters.

**Mid rail:** A rail parallel to and between a handrail and bottom rail or string.

**Handrail support:** A vertical piece of timber fixed between the string and handrail to strengthen the handrail and mid rail.

**String capping:** A timber member fixed to the top edge of the string to receive the balusters.

**False tenon:** A piece of hardwood inserted into a mortice in the newel post and a mortice or groove in the handrail and nailed in position. This type of joint allows easy assembly of rails to newel posts.

### A4 Construction Terms

**Going rod:** A rod on which is marked the going of each step, the going and the position of the landings i.e. the length of the flight.

**Height rod:** (storey rod) A rod on which is marked the rise of flights and the rise of each tread.

**Pitch board:** A triangular template, usually made of galvanised iron or plywood, one of its sides equal to the going, a side at right angles to the going equal to the riser. (A roof square plus fence would be an alternative).

**Margin line:** A line marked on the inside face of the string 38 to 50 mm parallel to the top edge. From this line the housings are usually positioned.

**Margin template:** A gauge used against the top edge of the string to mark the margin line. It is used in conjunction with the pitch board to mark out the locations of the treads and risers.

**Line of nosing or nosing line:** A line touching the front top edge of all the treads, landing and/or floor. It is a separate line to the margin line when the nosing of the tread projects in front of the face of the riser board.

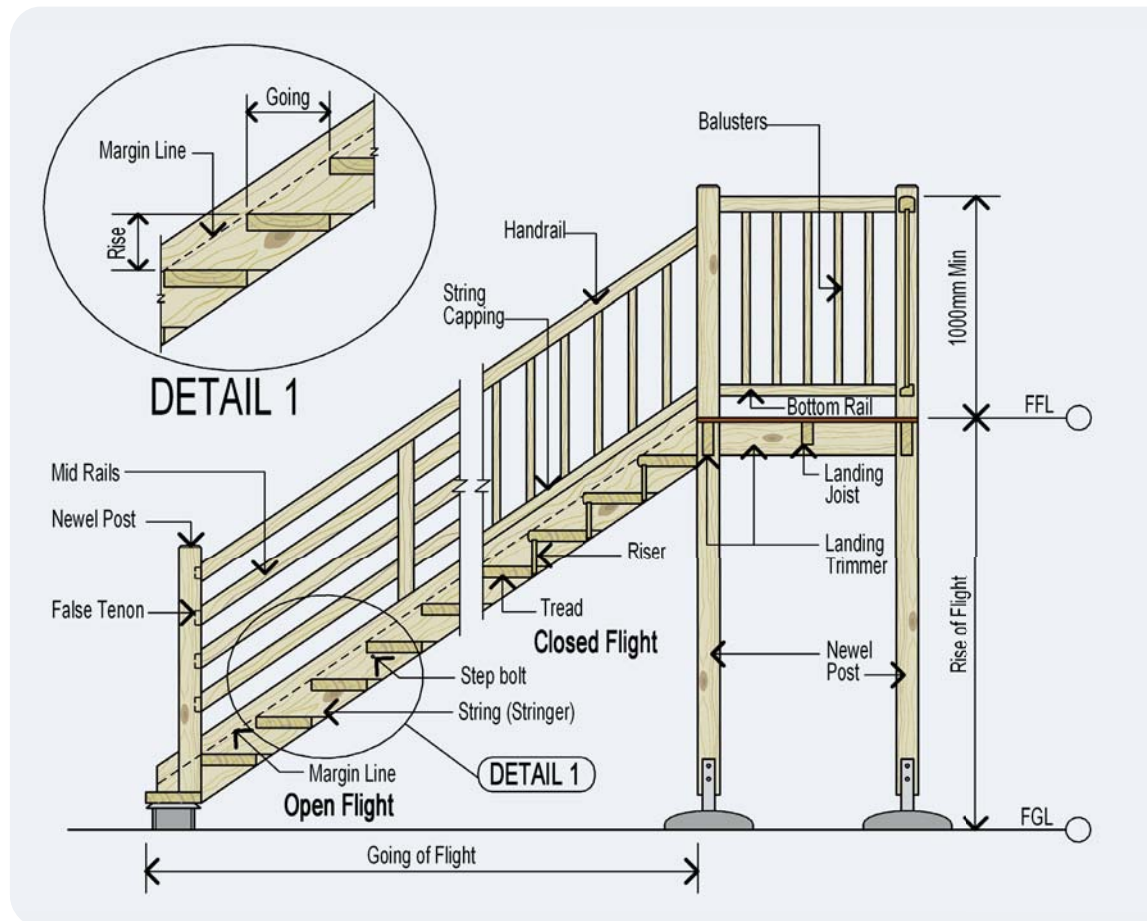
**Landing joist:** A beam that runs between landing trimmers to support the flooring or decking.

**Landing trimmer:** A beam at the front of a landing which supports the landing joists, newel posts and top of each flight.

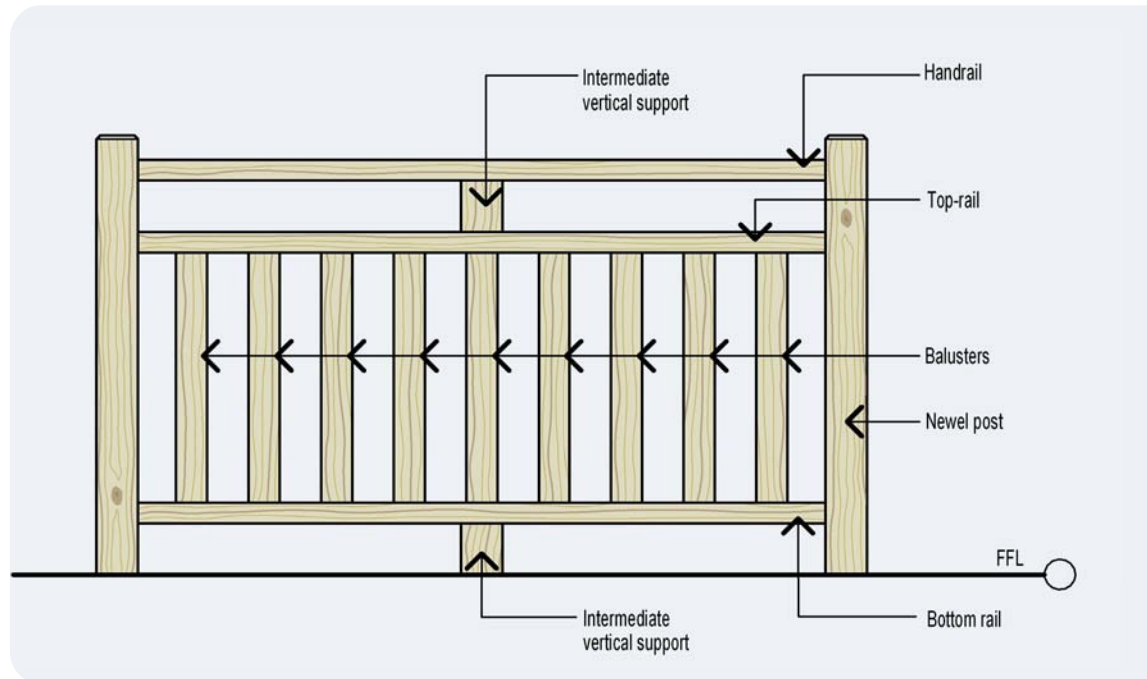
**Undercarriage or carriage piece:** An additional heavy timber support system fitted beneath wide stairs.

**Spandrel framing:** Vertical framing and panels which may infill the triangular space between the underside of the outer string and the floor.

**Stair soffit:** Plywood or plasterboard lining, etc, used to cover the underside of the stairs.



**Figure A1: Terminology – Stairs and landings.**



**Figure A2: Terminology – Balustrades and handrails.**

# B

## Appendix B – Stair Calculations

### B1 General

To obtain the facts required to be able to set out, order material and build stairs, some detailed measuring and calculating is necessary.

To suit the stock width of material available, stairs are usually built with a 240 to 250 mm going and a rise from 160 to 180 mm. See Section 2.

The rise can only be calculated from the total rise. The total rise should be measured with a tape from the lower floor level to the upper floor level. The total rise found may now be applied to a calculation (see B2).

To determine the total rise for external stairs where the ground is not level and either slopes toward or away from the building, refer to Appendix C.

The following problems are examples of how to find the unknown such as rise, going, number of rises and goings from the known facts, i.e. total rise and as in some cases the restricted space available for the total going of a stair as well as headroom.

## B2 Example 1

Straight flight of external stairs with the total rise = 2665 mm. The total going is unrestricted and the proposed treads will be 250 x 38 mm unseasoned hardwood.

### Calculate rise:

Divide the rise of the flight by a trial rise of 170 mm (for external stairs the rise is generally about 180 mm and for internal about 175 mm) to obtain the approximate number of rises.

$2665 \div 170 \text{ mm} = 15.67$ . This gives 15 risers at 170 mm and one at 115 mm. ( $2665 - (170 \times 15)$ )

Although it is allowable to have a different rise at the bottom of external stairs, this should be avoided where possible, so round off to the nearest whole number = 15.

Rise =  $(2665 \div 15) = 177 \text{ mm}$

Note: The result of the above calculation is 177.66 but we can round down up or down to the nearest whole number. If rounded down, the result is that the rise of the flight will be 10 mm less than the total rise of 2665. However, when the stairs are built to this and put in place, the treads will have a slight slope to the front, in this case just less than 1 mm per tread. This is acceptable and for external stairs can assist water to run off the treads.

### Calculate going:

The tread width is 250 mm so this can be our going. (Where an overhang on the tread is provided, the going will need to be adjusted accordingly.)

### Calculate total going:

There is always one less tread than the number of risers so the going of the flight will be:

$250 \text{ mm (the tread width)} \times 14 \text{ (15 risers - 1)} = 3500 \text{ mm}$ .

### Check results with BCA requirements:

**Rise:** 177 mm is within the range of 115 to 190 mm.

**Going:** 250 mm is within the range of 240 to 355 mm.

**Slope relationship:**  $177 \times 2 + 250$  (rise multiplied by 2 + the going) = 604 is within the range of 700 to 550 mm.

Another requirement of the BCA, that a 125 mm sphere must not pass through treads, should also be checked. The rise, 177 mm, less the tread thickness, 38 mm, must be less than 125 mm.

$177 - 38 = 137$ . This is more than 125 and so is not within the BCA requirement.

A cleat could be fixed under the tread above to close up the space to comply.

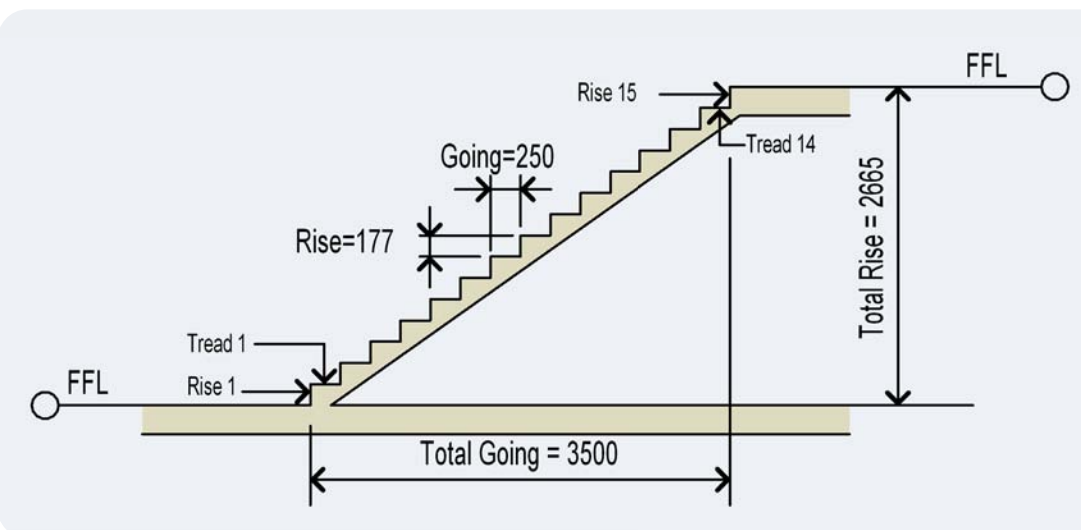


Figure B1

### B3 Example 2

An internal stair in a straight flight has a total rise of 2500 and the total going of the flight is 3200.

In this instance, we have a single flight with both the going and the rise of the flight given. The procedure is much the same as in the last problem.

#### Calculate rise:

Divide the rise of the flight by a trial rise of 170 mm to obtain the approximate number of rises:  $2500 \div 170 \text{ mm} = 14.70$ . This gives 14 risers at 170 mm and one at 120 mm.  $(2500 - (170 \times 14))$

It is not allowable to have a different rise at the bottom of internal stairs so round off to the nearest whole number = 14.

$$\text{Rise} = 2500 \div 14 = 178 \text{ mm}$$

Note: The result of the above calculation is 178.57 but we can round down to the nearest whole number. The result is that the rise of the flight will be 8 mm less than the total rise of 2500. However when the stairs are built to this and put in place, the treads will have a slight slope to the front, in this case about 0.5 mm per tread. This is acceptable. Where the slope to the front would exceed this, rounding up will be a better alternative as treads will then 'slope in' and be safer.

#### Calculate going:

In this example, the total going of the flight is 3200. Divide this by the number of treads (one less tread than the number of risers).

$$\text{Going} = 3200 \div 13 = 246 \text{ mm.}$$

#### Check results with BCA requirements:

**Rise:** 178 mm is within the range of 115 to 190 mm.

**Going:** 246 mm is within the range of 240 to 355 mm.

Number of treads is greater than 3 and less than 18.

**Slope relationship:**  $178 \times 2 + 246$  (rise multiplied by 2 + the going) = 602 is within the range of 700 to 550 mm.

The other BCA requirement, that a 125 mm sphere must not pass through treads, should also be checked. The rise, 178 mm, less the tread thickness, 38 mm, must be less than 125 mm.  $178 - 38 = 140$ . This is more than 125 and so is not within the BCA requirement. Add a cleat under the tread to close up the space.

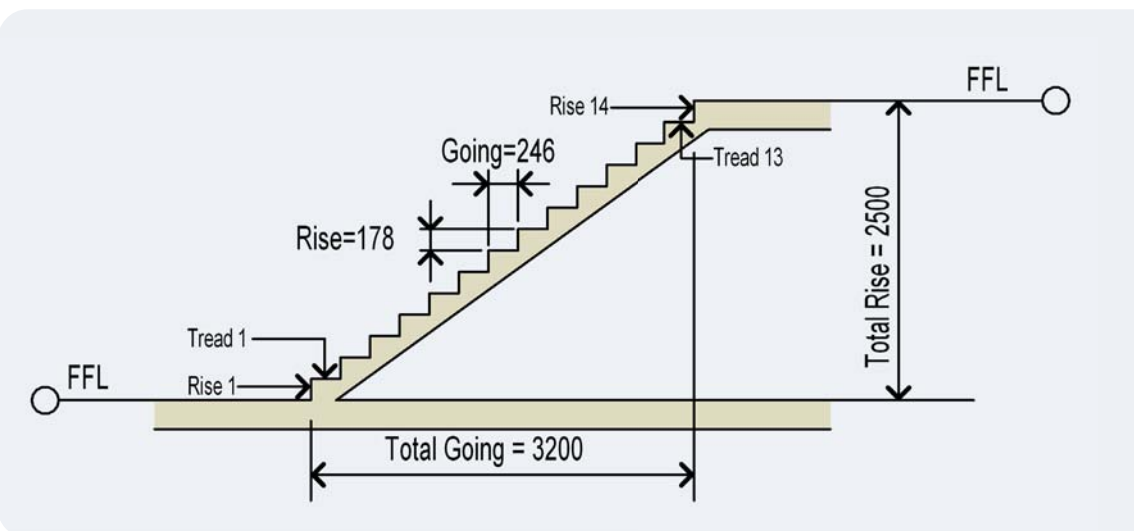


Figure B2

### B4 Example 3

Straight flight of external stairs with the total rise = 3600 mm. The total going is unrestricted and the proposed treads will be 250 x 50 mm unseasoned hardwood.

#### Calculate rise:

Divide the rise of the flight by a trial rise of 170 mm (170 is an average rise for stairs) to obtain the approximate number of rises.

$$3600 \div 170 \text{ mm} = 21.17 - \text{rounded off to the nearest whole number} = 21.$$

$$\text{Rise} = 3600 \div 21 = 171 \text{ mm (Rounded down as per the above examples)}$$

However, the number of risers exceeds that allowed by the BCA in a single flight (not more than 18) so a landing will need to be incorporated.

#### Calculate going:

The tread width is 250 mm so this can be our Going.

#### Calculate total going:

Flight 1 – 250 mm = 9 x 250 = 2250 mm plus Flight 2 – 250 mm = 10 x 250 = 2500 mm plus the landing width 900 mm = 5650 mm.

#### Check results with BCA requirements:

**Rise:** 171 mm is within the range of 115 to 190 mm.

**Going:** 250 mm is within the range of 240 to 355 mm

We have already established the number of treads is greater than 18 and a landing needs to be incorporated.

Slope Relationship:  $171 \times 2 + 250$  (rise multiplied by 2 + the going) = 592, within the range of 550 to 700 mm.

The other BCA requirement, that a 125 mm sphere must not pass through treads, should also be checked. The rise, 171 mm, less the tread thickness, 50 mm, must be less than 125 mm.  $171 - 50 = 121$ . This is less than 125 and so is within the BCA requirement.

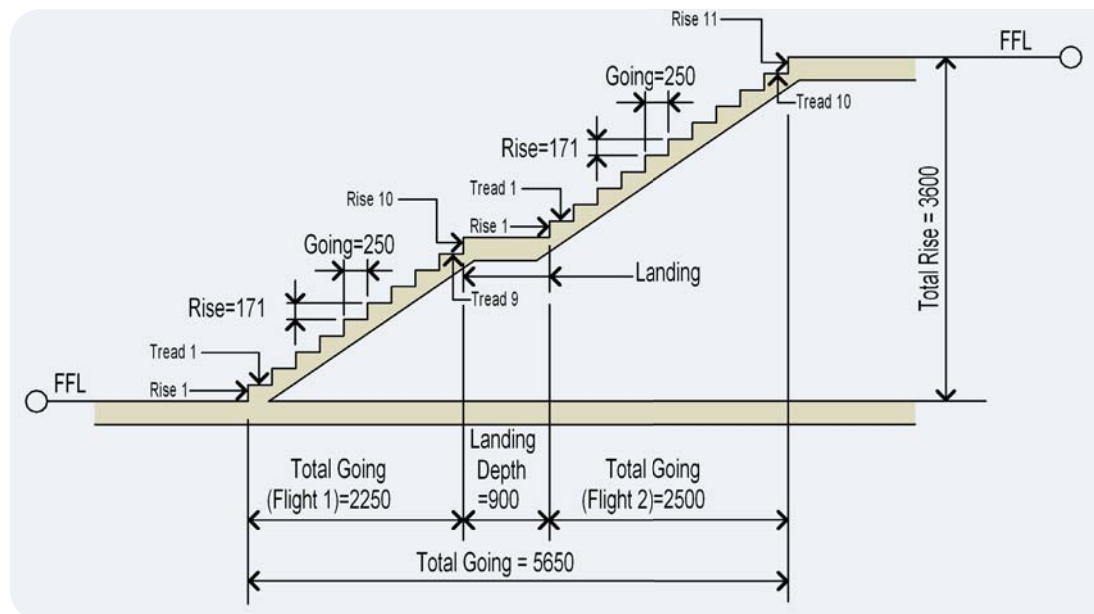


Figure B3

#### Slope relationship calculations:

The calculations to determine the slope relationship in the above examples worked out to be within the BCA requirement.

If the going plus twice the rise worked out to less than 550 this would indicate that the step was too small and the solution would be to leave out one step and do the calculation all over again.

If, on the other hand, the first trial rise and going caused the step to be too large (i.e. if the going plus twice the rise worked out to larger than 700) the solution would be to add another step.

## B5 Headroom for Stairs

The BCA minimum is 2000 mm, but 2100 mm is preferred.

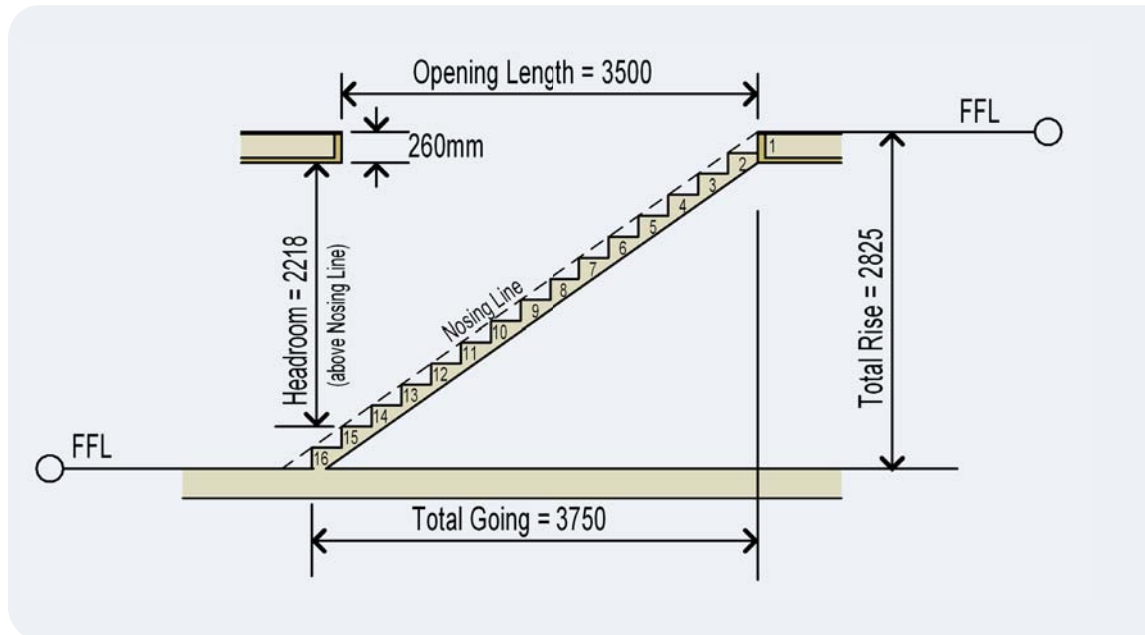
**Headroom or head way:** Provision should always be made for sufficient height so that the head of anyone will not strike against the edge of the landing or soffit above. This vertical height or space is called 'headroom' and it should not be less than 2000 mm. (The BCA minimum is 2000 mm, but 2100 mm is preferred).

The headroom in the stair shown in Figure B4 would be found by taking the number of risers contained within the opening of the floor (14), multiplying it by the rise and subtracting the depth of the floor. Note also that the length of the opening has the same number of treads (14) as there are risers in the headroom.

Assuming the stair in Figure B4 to have a rise of 177 mm and the depth of the floor 260 mm, the method of finding the headroom would be:

Rise x number of risers in the headroom portion of the stair minus the depth of the floor.

$$\begin{aligned}\text{Headroom} &= 177 \times 14 - 260 \\ &= 2478 - 260 \\ &= 2218 \text{ mm}\end{aligned}$$



**Figure B4**

For stairs in two flights, the method of finding the headroom is obtained by studying Figure B5. Note that the headroom is taken from the underside of the ceiling, at the corner of the trimmer, vertically down to the nosing line.

Count the risers from the top of the stairs down to the lower arrow point marking the headroom. There are 8 risers from the top of the stair to the top of the landing, and from the top of the landing to the top of the tread (indicated by the arrow point) there are 7 risers (one less than in the upper flight) making 15 in all.

Assuming a rise of 156 mm, take the height of these 15 risers:

$$156 \times 15 = 2340$$

Now subtract the thickness of the 225 mm upper floor:

$$= 2340 - 225 - \text{Headroom} = 2115 \text{ mm}$$

In other words, to find the headroom double the number of risers in the upper flight, subtract one, multiply by the rise then subtract the thickness of the upper floor (Figure B5). Apart from the flight shown in Figure B5, this applies to any flight with a landing including a straight stair, dog-leg flight, etc.

This may be written as a formula as:  $\text{Headroom} = R \times (U \times 2 - 1) - T$ , where:

R = rise

U = number of risers in upper flight

T = thickness of upper floor

The previous example can be calculated thus:

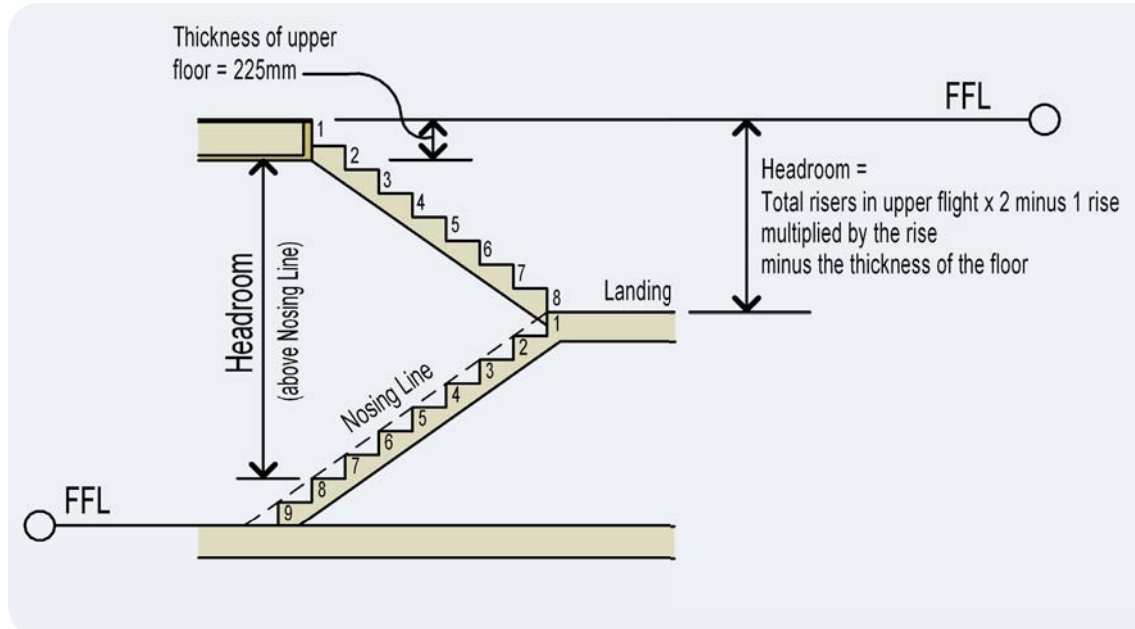
$$\text{Headroom} = R \times (U \times 2 - 1) - T$$

$$= 156 \times (8 \times 2 - 1) - 225$$

$$= 156 \times 15 - 225$$

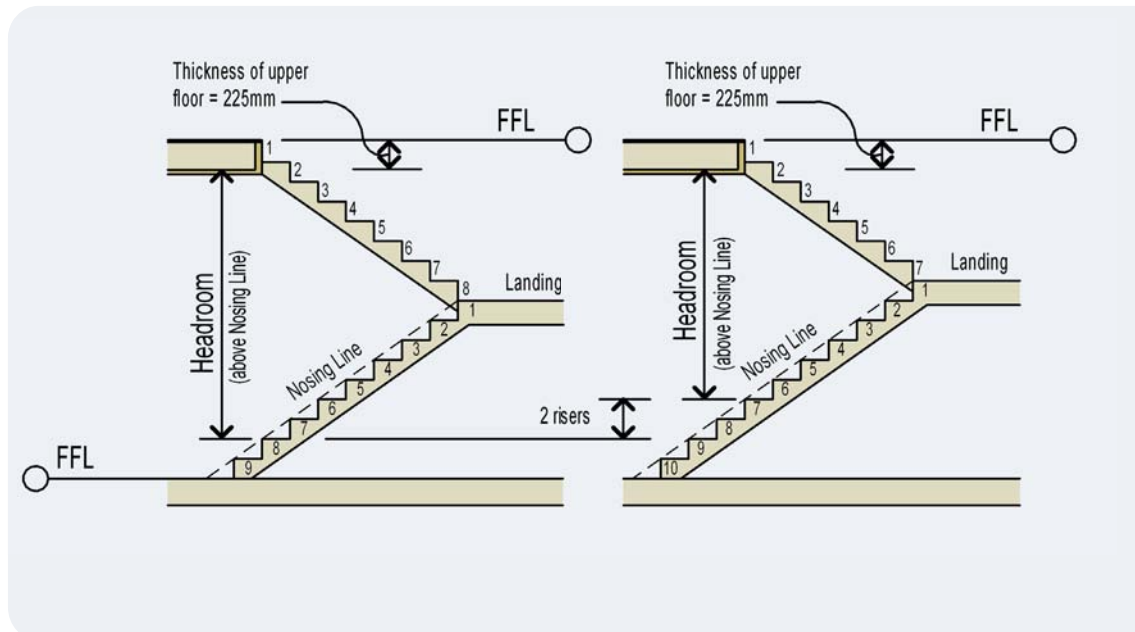
$$= 2340 - 225$$

$$= 2115$$



**Figure B5**

Note: A study of Figure B6 will show clearly the affect on headroom by taking one rise from the top flight and so adding one to the bottom flight; the result is a reduced headroom by two rises (e.g.  $2115 \text{ mm} - (156 \times 2) = \text{headroom of } 1803 \text{ mm}$  which would not be suitable).

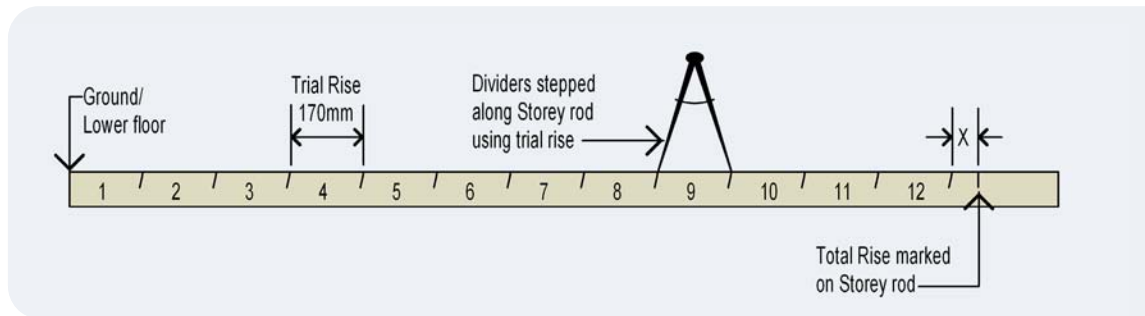


**Figure B6**



## B6 Practical Method for Calculating Number of Rises and the Rise

After marking the total rise onto a storey rod, a pair of carpenter's wing dividers should be set to a trial rise (165 to 170 mm) and then stepped along the storey rod to finish within the total rise. While doing this, the number of spaces should be counted and recorded (Figure B7).



**Figure B7**

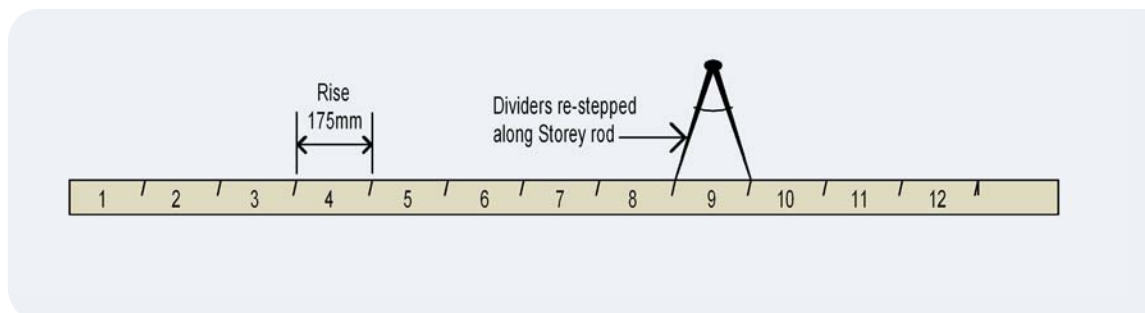
The distance between the last divider mark and the total rise mark on the storey rod (X) is now divided by the number of spaces counted and the result added to the first setting of the dividers.

$$\text{If } X = 60 \text{ mm then } 60 \div 12 = 5$$

$$\text{Trial rise } 170 \text{ mm} + 5 \text{ mm}$$

$$\text{Rise} = 175 \text{ mm}$$

Restep the dividers along the storey rod as a check, but now the last step should finish exactly on the total rise mark and the number of spaces or rises should be as before (Figure B8).



**Figure B8**

You should now have the number of rises and the exact rise and consequently the number of goings which is always one less than the number of rises. Remember that a landing is counted as a going so that when a landing is required in a stair there will be two flights and the number of treads in both flights will be two less than the total number of rises in the stair.

## B7 Quantity Calculations

### B7.1 String Length Required

This is normally determined by measurement from a full size set out of a section through the flight, showing the treatment of the string at both ends; however for ordering purposes, application of the rule 'number of treads in the flight x 300 mm + 500 mm' should provide sufficient material.

Note: The 500 mm allows for variations of treatment at top and bottom of the string.

Using Example 1 above:

$$\text{No. of treads in the flight} \times 300 \text{ mm} + 500 \text{ mm}$$

$$15 \times 300 \text{ mm} + 500 \text{ mm}$$

$$4500 \text{ mm} + 500 \text{ mm}$$

$$\text{String length} = 5000 \text{ mm}$$

Two strings of 5000 mm are required. (i.e. order 2 of 5.1 m)

### B7.2 Number of Treads

From the previous calculations in Examples 1, 2 and 3, the number of treads is known. The length of each tread will depend on the width of the stairs.

Using Example 1 above and width of flight = 900 mm:

No. of treads in the flight = 15  
Tread length = 900 mm  
15 treads @ 900 mm.

If these are ordered as 15 individual pieces, this does not allow very much margin for error or any end splits that may need to be cut off. Ordering 5 pieces 3000 mm long will allow a suitable amount without being uneconomical.

### B7.3 Tread Cutting Length

The cutting length of a tread will be the overall width of the stair minus twice the gauge depth (Figure B9).

Example:

Width of stair = 900 mm  
Housing depth = 15 mm  
String thickness = 50 mm

Tread cutting length =  $900 - (2 \times (50 - 15))$   
=  $900 - 70$   
= 830 mm



Figure B9: Tread cutting length.

# C

*These methods have generally been replaced by the use of laser levels, etc.*

## Appendix C – Total Rise Calculations – Sloping Ground

### C1 Determining Total Rise on Sloping Ground

The following guidance can be used to determine the total rise for external stairs where the ground is not level and either slopes toward or away from the building.

Note: These methods have generally been replaced by the use of laser levels, etc.

#### Method of finding the rise of stairs to sloping ground

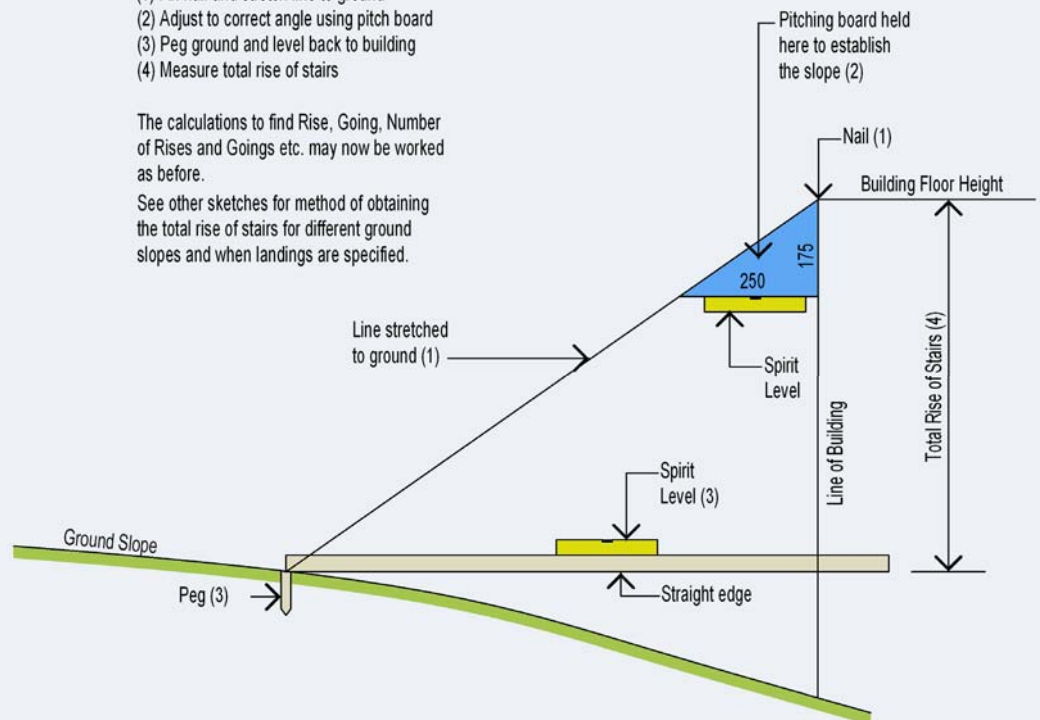
Note: Most external stairs are worked to a rise of 175mm and a going of 250mm

#### Procedure:

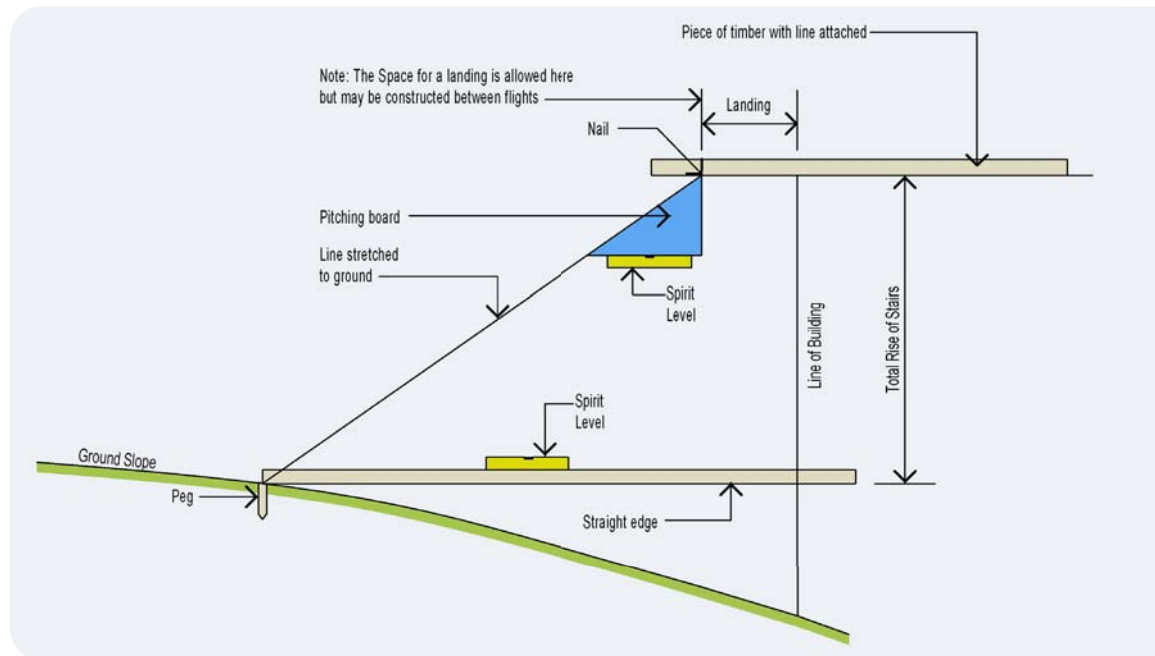
- (1) Fix nail and stretch line to ground
- (2) Adjust to correct angle using pitch board
- (3) Peg ground and level back to building
- (4) Measure total rise of stairs

The calculations to find Rise, Going, Number of Rises and Goings etc. may now be worked as before.

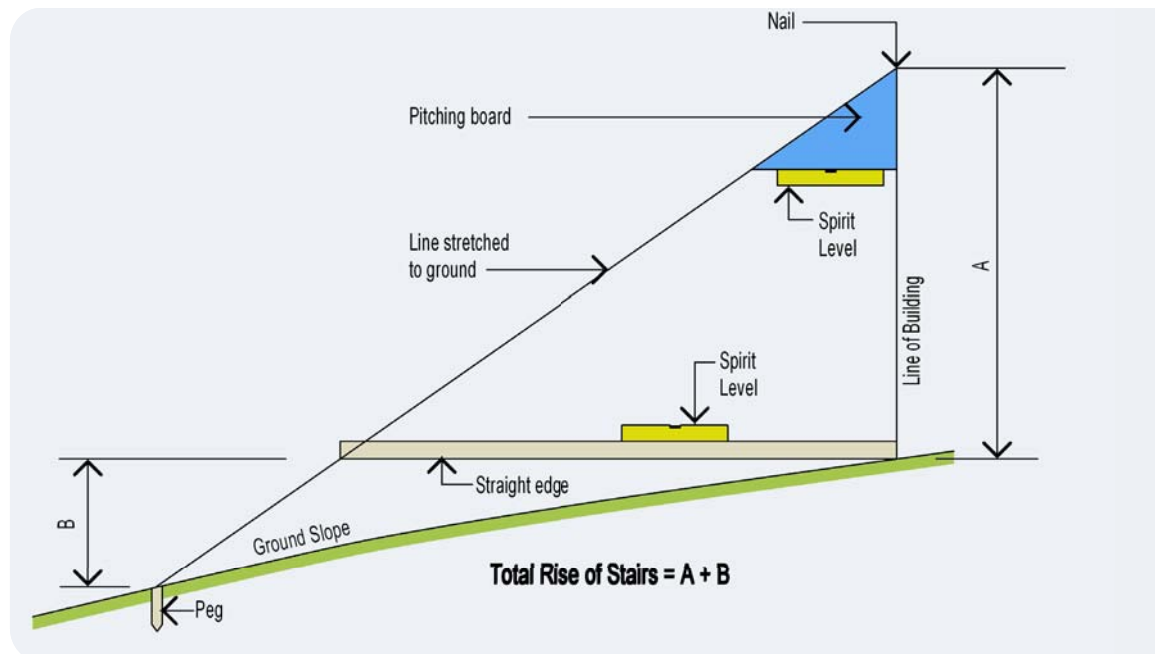
See other sketches for method of obtaining the total rise of stairs for different ground slopes and when landings are specified.



**Figure C1: Stairs without landing – Land sloping towards building.**

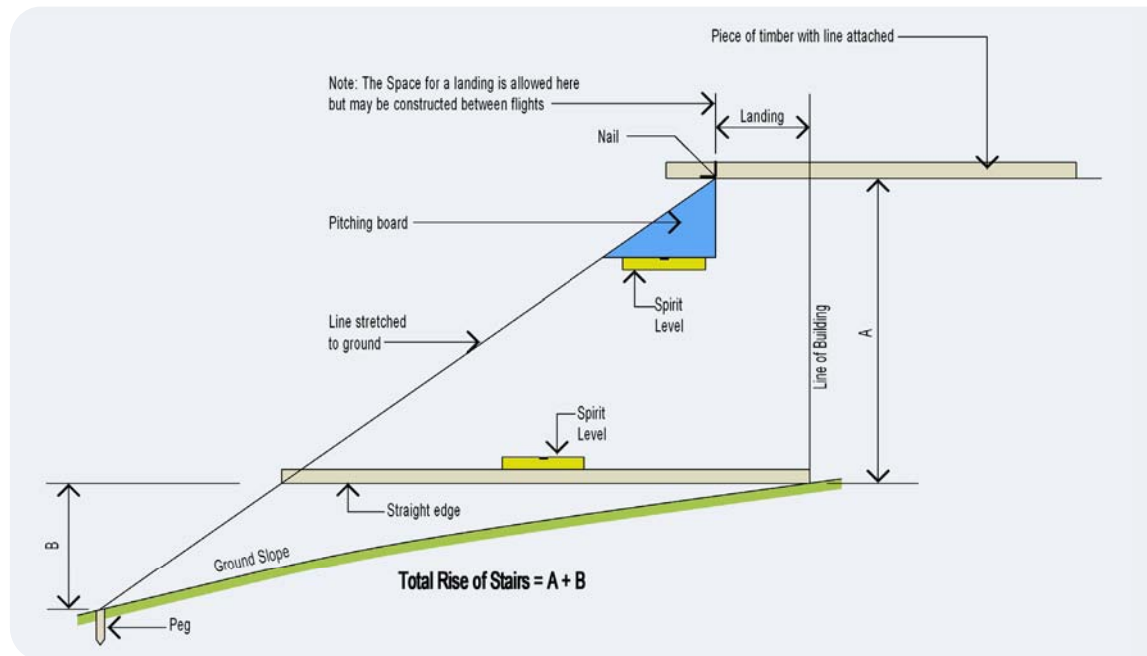


**Figure C2: Stairs with landing – Land sloping towards building.**



**Figure C3: Stairs without landing – Land sloping away from building.**

Note: this situation to be avoided wherever possible as it adds to the number of treads required.



**Figure C4: Stairs with landing – Land sloping away from building.**

Note: this situation to be avoided wherever possible as it adds to the number of treads required.





# WoodSolutions.com.au. The knowledge building website.

If you're looking to design or build a commercial, residential or industrial project - discover WoodSolutions, the website that's designed and constructed for you.

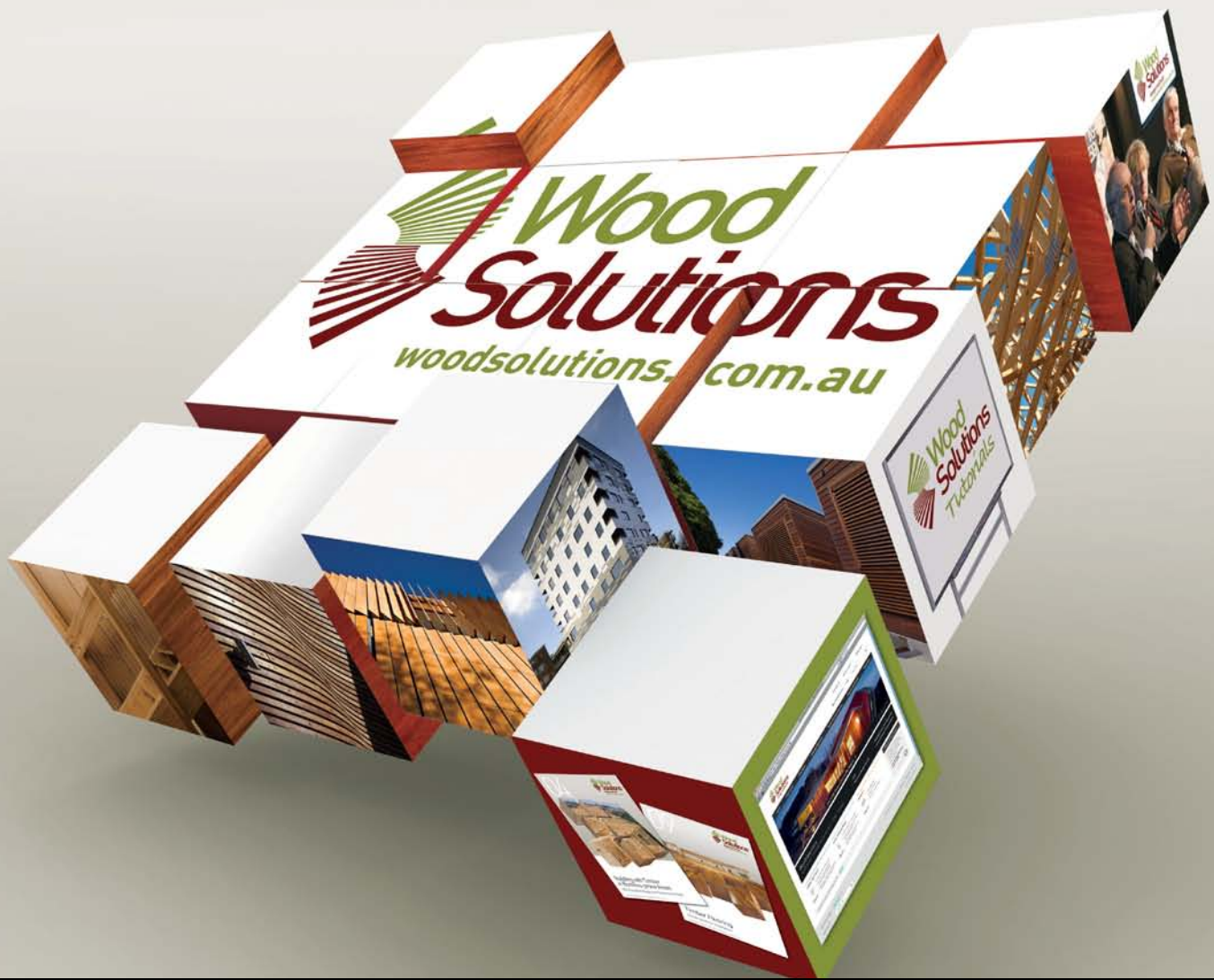
WoodSolutions is a world-leading initiative and a one stop source for a huge range of free, non-proprietary information, including:

- Technical Design Guides
- case studies
- workplace technical presentations
- conferences and seminars
- species information
- performance data
- fire information
- durability ratings
- fixings and finishes
- Standards and Codes, and much more.

Developed by the Australian forest and wood products industry, WoodSolutions contains information from industry bodies, manufacturers and suppliers.

Visit the WoodSolutions website today and build your knowledge.





# Discover more ways to build your knowledge of wood

If you need technical information or inspiration on designing and building with wood, you'll find WoodSolutions has the answers. From technical design and engineering advice to inspiring projects and CPD linked activities, WoodSolutions has a wide range of resources and professional seminars.

## **[www.woodsolutions.com.au](http://www.woodsolutions.com.au)**

Your central resource for news about all WoodSolutions activities and access to more than three thousand pages of online information and downloadable publications.

## **Technical Publications**

A suite of informative, technical and training guides and handbooks that support the use of wood in residential and commercial buildings.

## **WoodSolutions Tutorials**

A range of practical and inspirational topics to educate and inform design and construction professionals. These free, CPD related, presentations can be delivered at your workplace at a time that suits you.

## **Seminars and Events**

From one day seminars featuring presentations from leading international and Australian speakers to international tours of landmark wood projects, WoodSolutions offer a range of professional development activities.

## **What is WoodSolutions?**

Developed by the Australian forest and wood products industry for design and building professionals, WoodSolutions is a non-proprietary source of information from industry bodies, manufacturers and suppliers.

