

Ag 84A7
ch. 2

CONSTRUCTION GUIDES FOR EXPOSED WOOD DECKS

by
L. O. Anderson, T. B. Heebink,
and A. E. Oviatt

U. S. DEPT. OF AGRICULTURE
NATIONAL AGRICULTURAL LIBRARY
RECEIVED

OCT 5 1972

PROCUREMENT SECTION
CURRENT SERIAL RECORDS

ACKNOWLEDGEMENT

The authors wish to acknowledge the valued assistance of the organizations listed on page 5 of the report. Particular thanks are expressed to the technical staffs of the American Plywood Association and the Western Wood Products Association who helped develop Tables 2 through 6 and who reviewed the report in draft stage. Also, to staff members of the U. S. Forest Products Laboratory and the American Wood Preservers Institute for their helpful reviews of the draft.

Cover photo courtesy of Western Wood Products Association; figures 1, 2, 3 and 9 by photographer Charles R. Pearson; and figure 4 courtesy American Plywood Association.

ABSTRACT

Offers guides to the design, finishing, and treatment of outdoor wood decks to insure user satisfaction. Both good and poor construction details are amply illustrated for the benefit of architects, builders, and homeowners.

Keywords: Housing, construction materials, construction, forest products.

This booklet was originally issued by the Pacific Northwest Forest and Range Experiment Station, Portland, Oreg., as an unnumbered publication, October 1971.

CONSTRUCTION GUIDES FOR EXPOSED WOOD DECKS

by

L. O. Anderson, retired, formerly Research Engineer,
U. S. Forest Products Laboratory
T. B. Heebink, Research Engineer, Pacific Northwest
Forest and Range Experiment Station
and
A. E. Oviatt, Research Architect, Pacific Northwest
Forest and Range Experiment Station

July 1972

Agriculture Handbook No. 432

FOREST SERVICE, U. S. DEPARTMENT OF AGRICULTURE

For sale by the Superintendent of Documents, U.S. Government Printing Office
Washington, D.C. 20402 - Price 75 cents
Stock Number 0100-2577

TABLE OF CONTENTS

INTRODUCTION	1
Types of Decks	1
Low-level	1
Hillside	1
Rooftop	1
Planning a Deck	4
MATERIAL SELECTION	5
General	5
Lumber Species and Characteristics	5
Lumber sizes	6
Moisture content	6
Plywood Specifications	6
Decay Resistance of Wood	6
TREATMENTS, FINISHES, AND COVERINGS FOR DECKS	8
Preservative Treatments	8
Poles and posts	8
Lumber and timber for ground or water contact	8
Wood not in contact with ground	8
Plywood decks	9
Exterior Finishes for Wood	9
Natural finishes	9
Penetrating stains	9
Paint	9
Coverings and Coatings for Plywood Decks	9
DESIGN RECOMMENDATIONS	11
Framing Spans and Sizes	11
Post sizes	11
Beam spans	11
Joist spans	11
Deck board spans	11
Plywood decks	11
Fasteners	11
Wood screws	17
Lag screws	18
Bolts	18
Miscellaneous fastening methods	18
GENERAL RULES FOR DECK CONSTRUCTION	19
Guides for Fastener Use	19
Guides for Outdoor Wood Use	19

DECK CONSTRUCTION	21
Site Preparation	21
Grading and drainage	21
Weed and growth control	21
Footings	21
Footings for posts below grade	21
Footings for posts above grade	23
Post-to-Footing Anchorage	24
Poor design	24
Better design	28
Good design	28
Beam-to-Post Connection	28
Single beams	28
Double posts	34
Double or split beams	34
Small single beams	34
Beam-and-Joist-to-House Connections	34
Beams	34
Joists	34
Bracing	39
Types of bracing	42
Partial bracing	42
Fastening braces	42
Joist-to-Beam Connections	48
Joists bearing directly on the beams	50
Joists located between beams	50
Fastening Deck Boards	51
Fastening Plywood	54
Railing Posts	54
Deck Benches	56
High-deck benches	56
Low-deck benches	56
Railings	57
Horizontal railings	57
Rail fastenings	62
Cap rail connections	65
Miscellaneous rail connections	65
Stairways	67
Stair stringers	67
Tread and riser size	67
Tread support	67
Stair railings	73
REFERENCES	76
GLOSSARY	77

Figure 1. — Sheltered decks extend living areas.



Introduction

Outdoor living is becoming a way of life for the American family. Moderate seasons and climates stimulate special enthusiasm for outdoor living. Thus, there is a desire for the outdoor "living room," an area adjacent to the home for family enjoyment in pleasant weather.

This outdoor living area is often provided by a wood deck that adds spaciousness to a home at modest cost. A deck can expand or frame a view to increase a homeowner's enjoyment. It can serve as an adult entertainment center by night and a children's play area by day — being easily adapted to the activity or degree of formality desired (fig. 1).

Decks, which may offer the only means of providing outdoor living areas for steep hillside homes, have gained popularity for homes on level ground — as a way of adding charm, style, and livability. To achieve these gains, wood decks offer a variety of flexible, economical systems, and this publication suggests ways to insure the greatest satisfaction from such systems.

Types of Decks

Most of the decks considered here are low- or high-level decks with spaced floor boards and are attached to the house for access and partial support. There are, in addition, detached low-level decks and rooftop decks. The latter are simpler than others in some respects since they rely on the roof for primary support but do introduce a need to prevent leakage to the space below. Solid decks may be made of caulked planking or of plywood with a water-proof coating such as an elastomeric wearing surface.

Low-level wood decks may be chosen for their non-reflective and resilient qualities in preference to a paved patio (fig. 2). More frequently, the wood deck is chosen because of its design versatility and adaptability to varied use.

Low-level decks can be simply supported on concrete piers or short posts closely spaced, thereby simplifying the main horizontal structure. However, drainage can be a problem on low or level ground and provision to insure good drainage should be made before the deck is built. Good drainage not only keeps the ground firm to adequately support the deck but avoids dampness that could encourage decay in posts or sills.

Hillside decks were first in the line of residential decks — used as a means of creating outdoor living areas on steep sites (fig. 3). Despite their expense as compared with a level yard or patio, they add living area at much less cost than that of indoor space. Moreover, the outdoor setting adds a new dimension to the home and provides amenities that people prize.

The substructure of hillside decks is designed to provide solid support with a minimum number of members, especially if exposed to view from below. This may require a heavier deck structure and more substantial railings than are needed for low-level decks, but the general rules to insure satisfactory performance are the same.

Rooftop decks may cover a carport roof or a room of the house. One constructed over a carport may be relatively simple to build but may be difficult to handle aesthetically.

Where a rooftop provides the deck support, it may also serve as the floor, particularly if the deck is included in the initial construction. The roof must then be designed as a floor to support

Figure 2. — Low-level decks may feature simple construction.

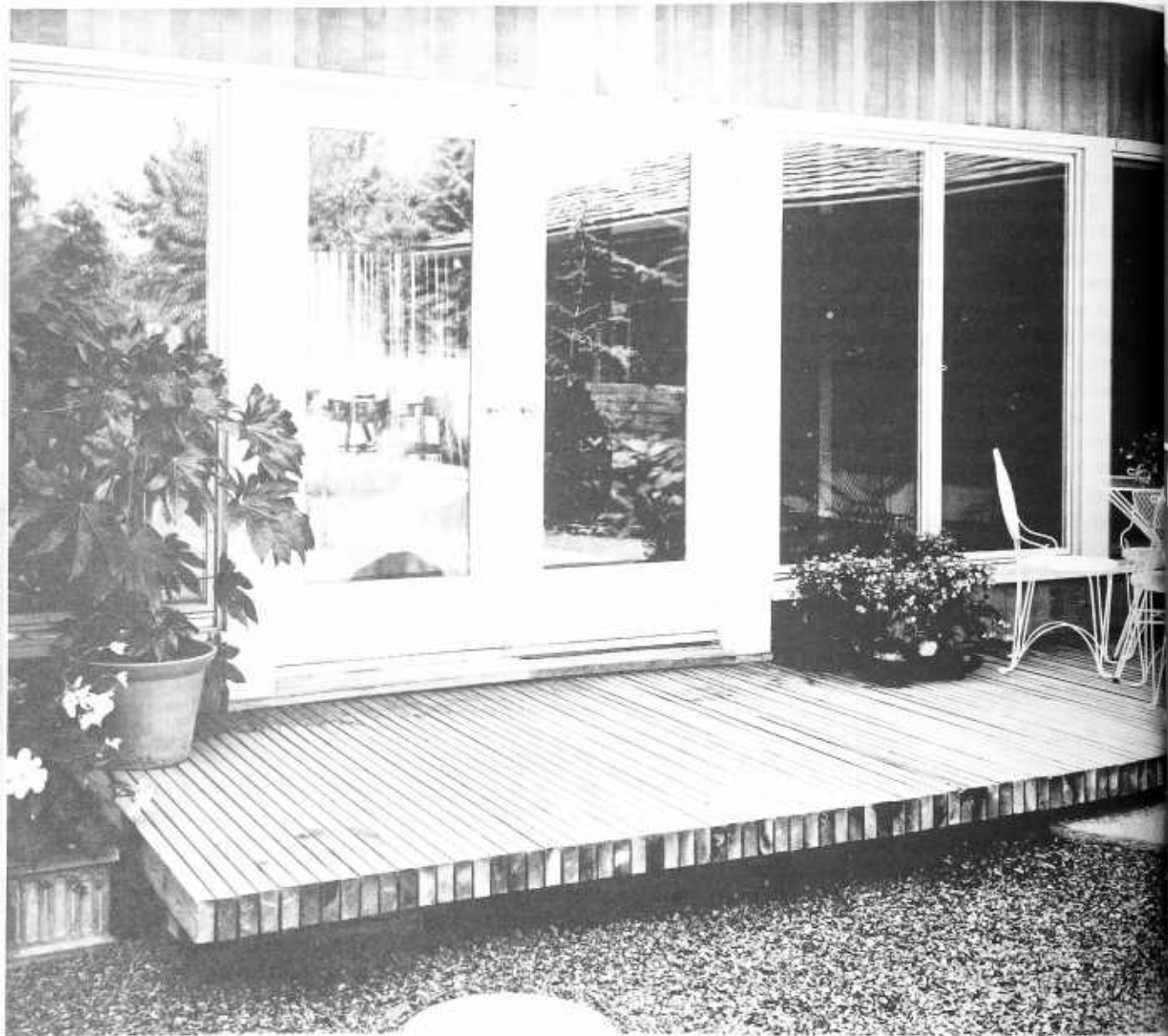
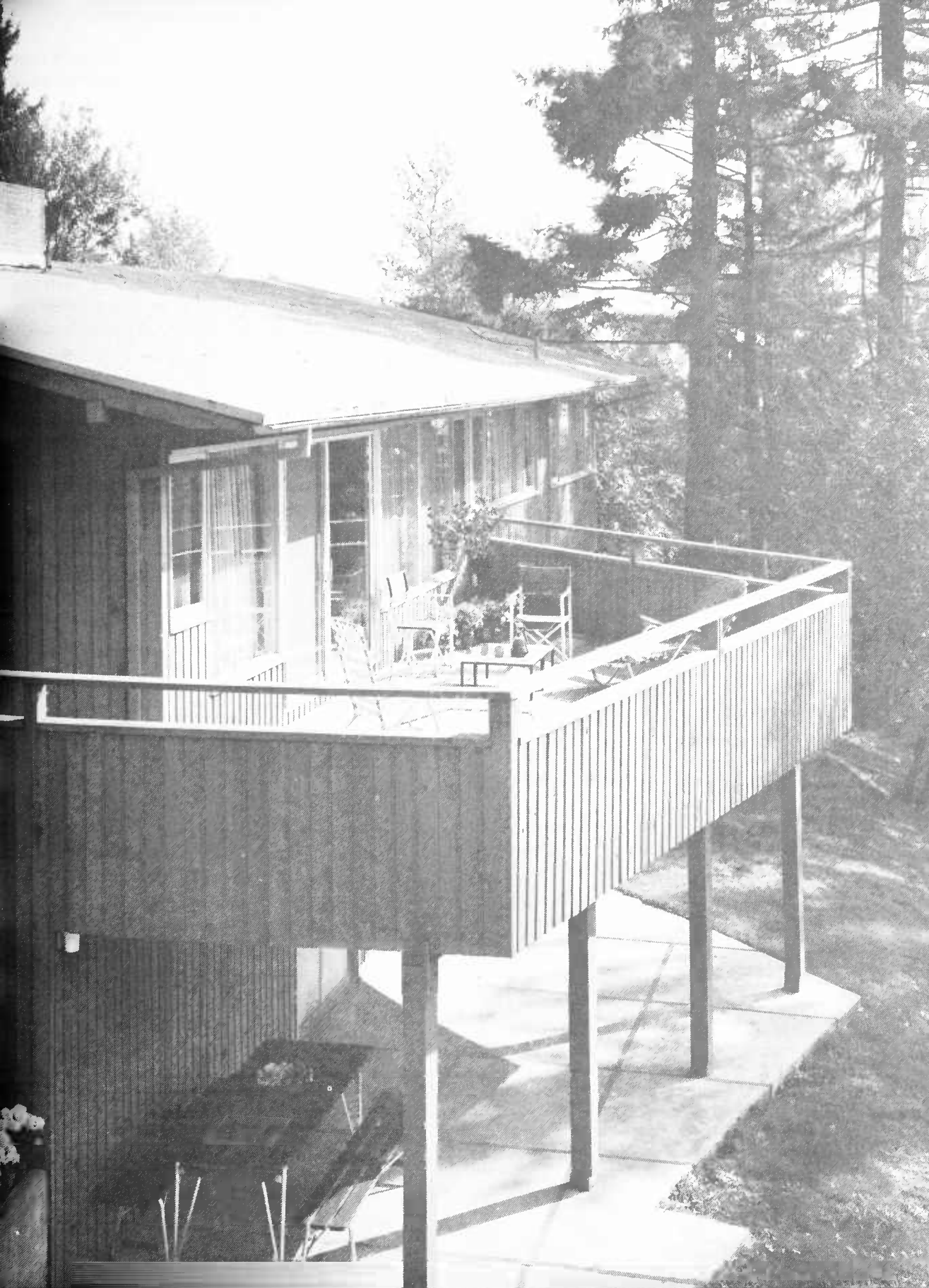

Figure 3. — High-level decks can improve privacy and out



the deck loads. If the deck is added to a completed house, it is more common to construct a separate deck floor over the roof.

Planning a Deck

A first step in planning a deck is to determine the requirements and limitations of the local building code. Limitations on height and width and required floor loads or railing resistance vary by locality and need to be checked before a deck is designed.

A choice between one large deck and two or more smaller decks may be influenced by code limitations, although the choice is more likely to be based on orientation, view, prevailing winds, steepness of the site, or anticipated desires of the owner.

Deciding deck location goes a long way toward determining the type of deck but leaves a wide choice in design. Where wood is selected as the deck material, there are many design con-

siderations that can contribute to deck durability and enhance the owner's enjoyment of this outdoor living area.

Planning a deck during the design of the house is certainly an advantage because it can then become an outdoor extension of the living or family room. It can also be designed as an outdoor portion of the dining room or kitchen with access through sliding doors or other openings. It is also desirable to take advantage of prevailing breezes with space for both sun and shade areas during the day. Sun shades can be used as a substitute for the natural shade provided by trees.

Providing a deck for an existing house is sometimes more difficult because the rooms may not be located to provide easy access to a deck. However, introduction of a new doorway in the house and a pleasant walkway to the deck area may provide a satisfactory solution to even the most difficult problem.

Table 1. — Broad classification of woods according to characteristics and properties¹

Kind of wood	Working and behavior characteristics							Strength properties			Freedom from pitch
	Hardness	Freedom from warping	Ease of working	Paint holding	Nail holding	Decay resistance of heartwood	Proportion of heartwood	Bending strength	Stiffness	Strength as a post	
Ash	A	B	C	C	A	C	C	A	A	A	A
Western red cedar	C	A	A	A	C	A	A	C	C	B	A
Cypress	B	B	B	A	B	A	B	B	B	B	A
Douglas-fir, larch	B	B	B-C	C	A	B	A	A	A	A	B
Gum	B	C	B	C	A	B	B	B	A	B	A
Hemlock, white fir ²	B-C	B	B	C	C	C	C	B	A	B	A
Soft pines ³	C	A	A	A	C	C	B	C	C	C	B
Southern pine	B	B	B	C	A	B	C	A	A	A	C
Poplar	C	A	B	A	B	C	B	B	B	B	A
Redwood	B	A	B	A	B	A	A	B	B	A	A
Spruce	C	A-B	B	B	B	C	C	B	B	B	A

¹A — among the woods relatively high in the particular respect listed; B — among woods intermediate in that respect; C — among woods relatively low in that respect. Letters do not refer to lumber grades.

²Includes west coast and eastern hemlocks.

³Includes the western and northeastern pines.

Material Selection

General

Although wood and wood products are the primary materials used in the construction of exposed decks, other materials such as fastenings and finishes are also important. Footings used to anchor the posts which support the deck proper are usually concrete. The proper combinations of all materials with good construction details will insure a deck which will provide years of pleasure.

In addition to the information contained in this manual and selected references, further data on the use of wood can be obtained from many wood trade associations, universities, and wood research laboratories, a few of which are included in the following list:

American Institute of Timber Construction
Englewood, Colorado 80110

American Plywood Association
Tacoma, Washington 98401

American Wood Preservers Bureau
Arlington, Virginia 22206

American Wood Preservers Institute
McLean, Virginia 22101

California Redwood Association
San Francisco, California 94111

National Forest Products Association
Washington, D. C. 20036

Southern Forest Products Association
Metairie, Louisiana 70002

U. S. Forest Products Laboratory
Madison, Wisconsin 53705

Western Wood Products Association
Portland, Oregon 97204

These organizations should always be considered as sources of specific information. However, it is the purpose of this manual to

provide general guides to the proper construction of outdoor wood decks and related units. Illustrations of "poor" as well as "good" practices will be included in many instances.

Lumber Species and Characteristics

Many lumber species will provide good service in a wood deck. However, some are more adequate for the purpose than others. To select lumber wisely, one must first single out the key requirements of the job. Then it is relatively easy to check the properties of the different wood to see which ones meet these requirements. For example, beams or joists require wood species that are high in bending strength or stiffness; wide boards in railings or fences may best be species that warp little; posts and similar members that are exposed to long wet periods should be heartwood of species with high decay resistance. Species information is included in Agriculture Information Bulletin No. 311, Selection and Use of Wood Products for Home and Farm Buildings (3). That bulletin lists major items of construction with usual requirements and the species which best combine these requirements. As an example:

DECKING AND OUTDOOR STEPPING

Usual requirements: High decay resistance, non-splintering, good stiffness, strength, wear resistance, and freedom from warping. Woods with heartwood that combine these requirements from a high to a good degree include — cypress, white oak, locust, Douglas-fir, western larch, redwood, cedar, and southern pine.

The classification of woods commonly used in the United States according to their characteristics is given in table 1. Follow the recommendations in this table in selecting wood for a specific use in the outdoor structure.

Plywood is a wood product adaptable for use in wood decks and is often recommended for solid deck coverings (fig. 4). A listing of the five species groups used in the manufacture of softwood plywood is included in U. S. Product Standard PS 1-66 (10). In general, those species of interest for decks are grouped as shown in tables 1, 2, and 3, except that western red cedar, sugar pine, eastern white pine, and Engelmann spruce are excluded from group 3 for plywood and placed in group 4.

Plywood is made in two types — Exterior and Interior. Only Exterior type is recommended where any surface or edge is permanently exposed to the weather. Interior type plywood, even when made with exterior glue and protected on the top surface, is not recommended for such exposures.

Lumber sizes. — The size of lumber is normally based on green sawn sizes. When the lumber has been dried and surfaced, the finish size (thickness and width) is somewhat less than the sawn size.

The following lumber sizes are those established by the American Lumber Standards Committee.

Nominal (inches)	Dry (inches)	Green (inches)
1	3/4	25/32
2	1-1/2	1-9/16
4	3-1/2	3-9/16
6	5-1/2	5-5/8
8	7-1/4	7-1/2
10	9-1/4	9-1/2
12	11-1/4	11-1/2

For example, a nominal 2 by 4 would have a surfaced dry size of 1½ by 3½ inches at a maximum moisture content of 19 percent.

Moisture content of wood during fabrication and assembly of a wood frame structure is important. Ideally, it should be about the same moisture content it reaches in service. If green or partially dried wood is used, wood members usually shrink, resulting in poorly fitting joints and loose fastenings after drying has occurred.

Although not as important for exterior use as for interior use, the moisture content of lumber used and exposed to exterior conditions should be considered. The average moisture content of wood exposed to the weather varies

with the season, but kiln dried or air dried lumber best fits the mid-range of moisture contents that wood reaches in use.

Plywood Specifications

For solid deck applications with direct exposure to the weather, plywood marked C-C Plugged Exterior, or Underlayment Exterior (C-C Plugged) may be specified. Higher grades, such as A-C or B-C Exterior, may also be used. These grades coated with a high performance wearing surface are commonly used for residential deck areas.

High Density Overlay (HDO) plywood having a hard, phenolic-resin impregnated fiber surface is often used for boat decks with a screened, skid-resistant finish specified. HDO may be painted with standard deck-type paints, if desired, but is usually used without further finish.

Medium Density Overlay (MDO) plywood having a softer resin-fiber overlay requires either a high-performance deck paint, or an elastomeric deck coating system, depending on the intended use.

For premium deck construction, Plyron (plywood with a tempered hardboard face) may be used in conjunction with an elastomeric deck coating.

Plywood specifications for decks are summarized in table 6.

Decay Resistance of Wood

Every material normally used in construction has its distinctive way of deteriorating under adverse conditions. With wood it is decay. Wood will never decay if kept continuously dry (at less than 20-percent moisture content). Because open decks and other outdoor components are exposed to wetting and drying conditions, good drainage, flashings, and similar protective measures are more important in decks than in structures fully protected by a roof.

To provide good performance of wood under exposed conditions, one or more of the following measures should be taken:

- (1) Use the heartwood of a decay-resistant species.
- (2) Use wood that has been given a good preservative treatment.

(3) Use details which do not trap moisture and which allow easy drainage. (A combination of (1) and (3), for example, is considered adequate, and (2) is satisfactory alone, but usually at increased cost if pressure treatment is used, or at the expense of increased maintenance if dip

or soak treatments are used. Detailing that allows quick drying is always desirable and will be emphasized here).

Frequently, it is cheaper and easier to use a good connection design than to use an inferior detail with a decay-resistant wood.

Figure 4. — Solid carpeted decks harmonize interior and exterior living areas.



Treatments, Finishes, and Coverings for Decks

Preservative Treatments

The best treatment of wood to assure long life under severe conditions is a pressure preservative treatment (9). However, most of the wood parts of a deck are exposed only to moderate conditions except at joints and connections. There are two general methods of preservative treatment of wood, (a) pressure processes applied commercially according to American Wood-Preservers' Association (AWPA) standards (2) which provide lasting protection; (b) non-pressure processes which normally penetrate the ends and a thin layer of the outer surfaces and require frequent maintenance. The non-pressure processes refer to treatments with water-repellent wood preservatives.

Two general types of preservatives are recommended for severe exterior conditions: (a) oils, such as creosote, or pentachlorophenol in oil or liquified gas carriers, and (b) non-leachable salts, such as the chromated copper arsenates or ammoniacal copper arsenite applied as water solutions. Both types are adequately described in the AWPA book of standards (2).

Poles and posts (severe conditions). — Treatment of poles and posts which are in contact with the soil should comply with the latest Federal specification TT-W-571i or with AWPA standards (2). Insist that the wood material you buy for these purposes has been treated according to these recommended practices.

Lumber and timber for ground or water contact (severe conditions). — Wood used under severe conditions such as ground contact may be pressure treated as recommended for poles and posts. However, if cleanliness or paintability is a factor, creosote or pentachloro-

phenol in heavy oil should not be used. AWPA standards for non-leachable water-borne preservatives and pentachlorophenol in light or volatile petroleum solvents should be selected (2).

Wood not in contact with ground. — Where preservative treatment is desirable because the more decay-resistant woods are not available, the use of a more easily applied, less expensive but less effective non-pressure treatment may be considered for joints, connections, and other critical areas. A pentachlorophenol solution with a water repellent is one of the more effective materials of this type. It is available at most lumber or paint dealers as a clear, water-repellent preservative which should perform in accordance with Federal specification TT-W-572. Sears, Roebuck & Company's "Wood Tox" is one of many products available.¹

These materials should be applied by soaking, dipping, or flooding so that end grain, machine cuts, and any existing checks in the wood are well penetrated. Dipping each end of all exterior framing material in water-repellent preservative is recommended, and this should be done after all cutting and drilling is completed. Drilled holes can be easily treated by squirting preservative from an oil can with a long spout. Dry wood absorbs more of these materials than partially dry wood and, consequently, is better protected.

¹Trade names are used only for the information and convenience of readers. Such use does not constitute endorsement by the U. S. Dept. of Agriculture of any product to the exclusion of others that may be suitable.

Plywood decks. — Preservative treatments for plywood decks are covered by the same standards as those for lumber and may be applied by pressure or superficial soaking or dipping. Several types of treatments perform well on plywood; but some deck applications require specific treatments, and the compatibility of the treatment with finish materials should always be checked.

Light, oil-borne preservatives and water-borne preservatives, such as those recommended for lumber, should be used when a clean, odorless, and paintable treatment is required. For maximum service from plywood decks, these preservatives should be pressure applied.

Exterior Finishes for Wood

Exterior finishes which might be considered for wood components exposed to the weather include natural finishes, penetrating stains, and paints. In general, natural finishes containing a water repellent and a preservative are preferred over paint for exposed flat surfaces. The natural finishes penetrate the wood and are easily renewed, but paint forms a surface film that may rupture under repeated wetting and drying. Exposed flat surfaces of decks, railings, and stairways are more vulnerable to paint film rupture than are vertical sidewall surfaces. Therefore, a completely satisfactory siding paint may not be suitable for a deck.

Natural finishes (lightly pigmented) are often used for exposed wood decks, railings, and stairways, not only because they can be easily renewed but because they enhance the natural color and grain of the wood. Such finishes can be obtained in many colors from a local paint dealer. Light colors are better for deck surfaces subject to traffic, as they show the least contrast in grain color as wear occurs and appearance is maintained longer.

One type of natural finish contains paraffin wax, zinc stearate, penta concentrate, linseed oil, mineral spirits, and tinting colors. Such finishes are manufactured by many leading producers of wood stains and are generally available from paint or lumber dealers. Formulas for several finishes of this type are also outlined in a report of the U. S. Forest Products Laboratory (7).

Penetrating stains (heavily pigmented) for rough and weathered wood may be used on the large sawn members such as beams and posts. These are similar to the natural finishes just described but contain less oil and more pigment. They are also produced by many companies.

Paint is one of the most widely used finishes for wood. When applied properly over a paintable surface with an initial water-repellent preservative treatment, followed by prime and finish coats, paint is a highly desirable finish for outdoor structures or as an accent color when used with natural finishes. Exposed flat surfaces with end or side joints are difficult to protect with a paint coating unless there is no shrinking or swelling of the wood to rupture the paint film. A crack in the paint film allows water to get beneath the film where it is hard to remove by drying. Retention of such moisture can result in eventual decay. Proper application methods and materials have been published by the U. S. Forest Products Laboratory (8).

Good painting practices include an initial application of water repellent preservative. After allowing two sunny days for drying of the preservative, a prime coat is applied. This can consist of a linseed oil-base paint with pigments that do not contain zinc oxide.

The finish coats can contain zinc oxide pigment and can be of the linseed oil, alkyd, or latex type. Two coats should be used for best results. A three-coat paint job with good-quality paint may last as long as 10 years, when the film is not ruptured by excessive shrinking or swelling of the wood.

Coverings and Coatings for Plywood Decks

Tough, skid-resistant, elastomeric coatings are available for plywood deck wearing surfaces. These coatings include liquid neoprene, neoprene/Hypalon, and silicone- or rubber-based materials. Plywood joints for these systems are usually sealed with a high performance caulk such as a silicone or Thiokol (silicone caulks require a primer). Joints may also be covered with a synthetic reinforcing tape, prior to application of the final surface coat, when an elastomeric coating system is used.

Silicone or Thiokol caulks are applied to 1/4-inch gaps between plywood panels over some type of filler or "backer" material — such as a foam rod. The caulk "bead" is normally about one-fourth inch in diameter. An alternate method is to bevel the panel edges first, then fill the joint with the caulk before the finish coating is applied.

For a premium quality joint, reinforcing tape is sometimes applied as a flashing over sealed joints. Reinforcing tape can also be used over cant strips at wall-to-deck corner areas and over unsealed plywood joints. For these applications, the tape flashing is embedded in a base coat of the elastomeric deck coating. Specific installation procedures and recommendations are readily available from manufacturers of the various deck coating systems and from the American Plywood Association. Their installation recommendations should be carefully followed.

Where plywood must be installed under wet conditions, the primer or first coat may be applied in the factory or under shelter at the

site prior to installation of the panels. In general, the first coat of coating systems for plywood should be applied to a dry, fresh wood surface. Where preservatives are used, the surface should be scraped or sanded to remove any residue produced by the preservative before the prime coat is applied. Finish coats of most systems require a dry clean surface, for best results.

If outdoor carpeting is to be used on plywood exposed to the weather, it is advisable to use pressure preservative treated plywood, with the underside well ventilated, for both low and elevated decks. Since carpeting is relatively new as an exterior surface material, specific information on its long-term performance when used on plywood under severe exposure is not available. Carpet may be readily applied to untreated plywood deck areas that are not subject to repeated wetting.

Canvas is sometimes used as a wearing surface on plywood. It should be installed with a waterproof adhesive, under dry conditions. A canvas surface well fused to the plywood may be painted with regular deck paints.

Design Recommendations

Framing Spans and Sizes

The allowable spans for decking, joists, and beams and the size of posts depend not only on the size, grade, and spacing of the members but also on the species. Species such as Douglas-fir, southern pine, and western larch allow greater spans than some of the less dense pines, cedars, and redwood, for example. Normally, deck members are designed for about the same load as the floors in a dwelling.

The arrangement of the structural members can vary somewhat because of orientation of the deck, position of the house, slope of the lot, etc. However, basically, the beams are supported by the posts (anchored to footings) which in turn support the floor joists (fig. 5). The deck boards are then fastened to the joists. When beams are spaced more closely together, the joists can be eliminated if the deck boards are thick enough to span between the beams. Railings are located around the perimeter of the deck if required for safety (low-level decks are often constructed without edge railings). When the deck is fastened to the house in some manner, the deck is normally rigid enough to eliminate the need for post bracing. In high free-standing decks, the use of post bracing is good practice.

Post sizes. — Common sizes for wood posts used in supporting beams and floor framing for wood decks are 4 by 4, 4 by 6, and 6 by 6 inches. The size of the post required is based on the span and spacing of the beams, the load, and the height of the post. Most decks are designed for a live load of 40 pounds per square foot with an additional allowance of 10 pounds per square foot for the weight of the material. The suggested sizes of posts required for various heights under several beam spans and spac-

ings are listed in table 2. Under normal conditions, the minimum dimension of the post should be the same as the beam width to simplify the method of fastening the two together. Thus a 4- by 8-inch (on edge) beam might use a 4- by 4-inch or a 4- by 6-inch post depending on the height, etc.

Beam spans. — The nominal sizes of beams for various spacings and spans are listed in table 3. These sizes are based on such species as Douglas-fir, southern pine, and western larch for one group, western hemlock and white fir for a second group, and the soft pines, cedars, spruces, and redwood for a third group. Lumber grade is No. 2 or Better.

Joist spans. — The approximate allowable spans for joists used in outdoor decks are listed in table 4 — both for the denser species of Group 1 and the less dense species of Groups 2 and 3. These spans are based on strength (40 pounds per square foot live load plus 10 pounds per square foot dead load) with deflection not exceeding 1/360 of span.

Deck board spans. — Deck boards are mainly used in 2-inch thickness and in widths of 3 and 4 inches. Because deck boards are spaced, spans are normally based on the width of each board as well as its thickness. (Roof decking, with tongue and groove edges and laid up tight, has greater allowable spans than spaced boards.) Decking can also be made of 2- by 3-inch or 2- by 4-inch members placed on edge, or of 1- by 4-inch boards. Deck boards are listed in table 5.

Plywood decks. — Spans for plywood decks are shown in table 6.

Fasteners

The strength and utility of any wood struc-

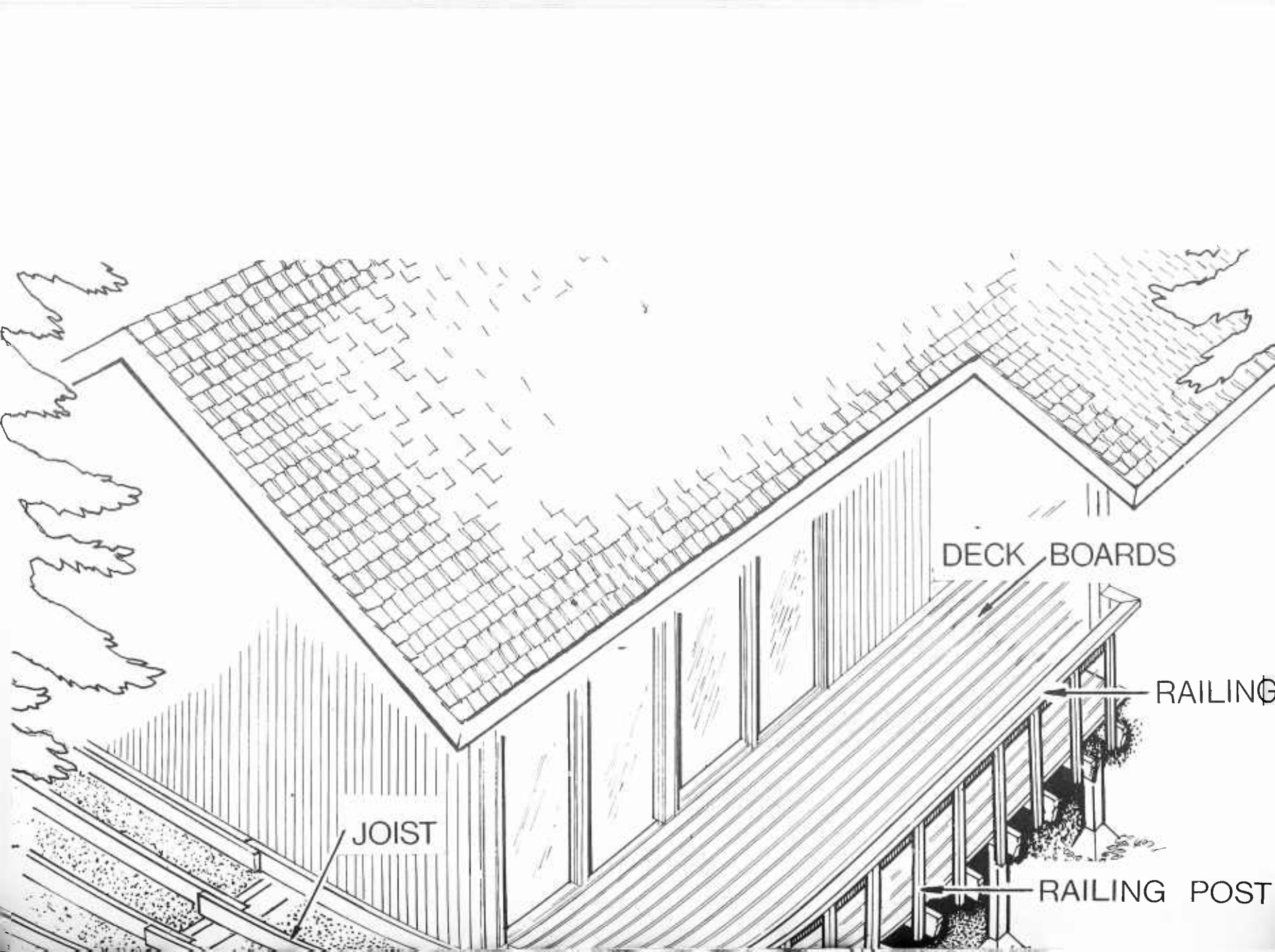

JOIST

DECK BOARDS

RAILING

RAILING POST

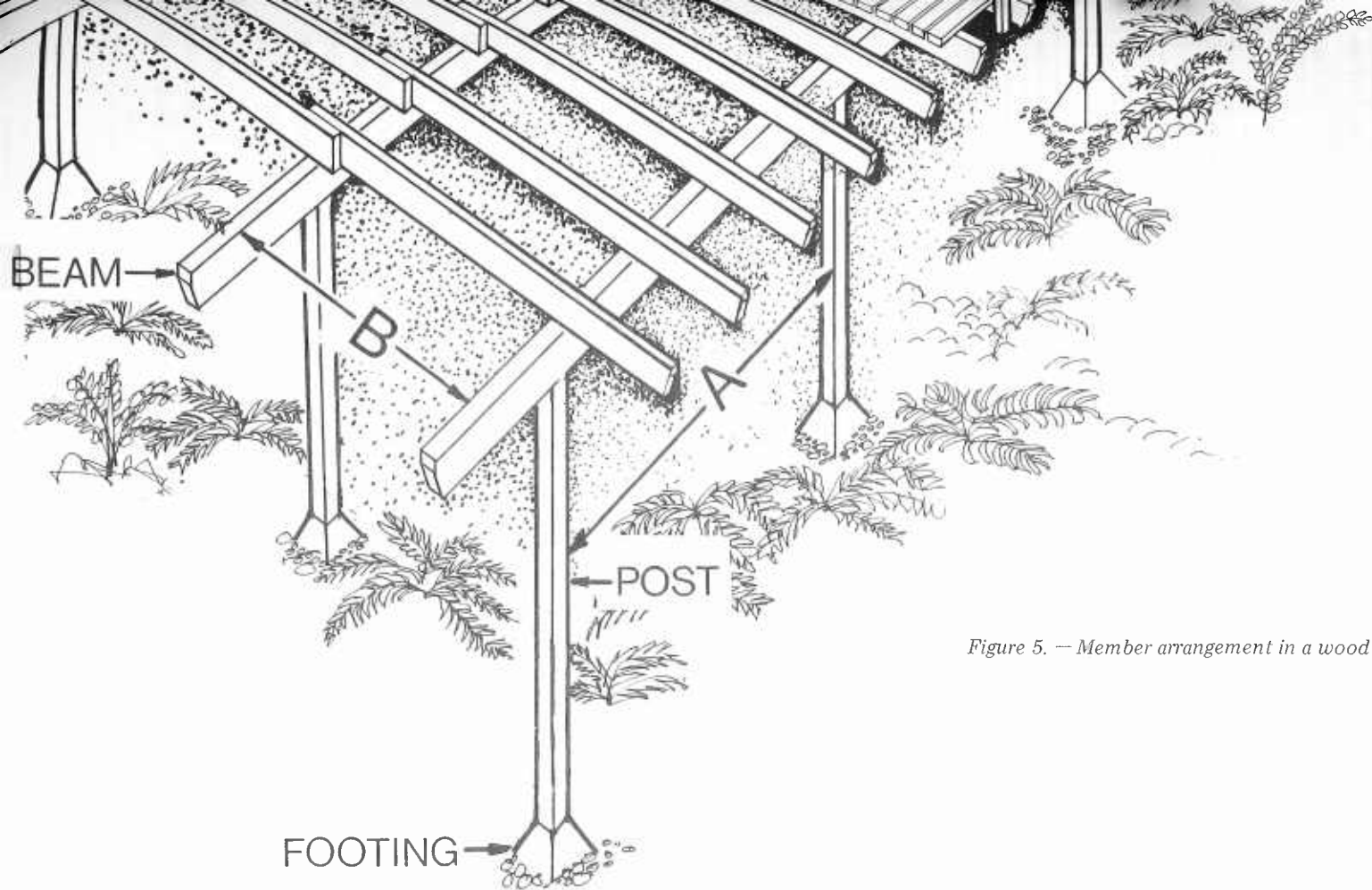

Figure 5. — Member arrangement in a wood deck.

Table 2. — Minimum post sizes (wood beam supports)¹

Species group ²	Post size (in.)	Load area ³ beam spacing x post spacing (sq. ft.)									
		36	48	60	72	84	96	108	120	132	144
1	4x4	Up to 12-ft. heights →				Up to 10-ft. heights →			Up to 8-ft. heights →		
	4x6					Up to 12-ft. heights →				Up to 10-ft. →	
	6x6									Up to 12-ft. →	
2	4x4	Up to 12-ft. →		Up to 10-ft. hts. →			Up to 8-ft. heights →				
	4x6			Up to 12-ft. hts. →			Up to 10-ft. heights →				
	6x6						Up to 12-ft. heights →				
3	4x4	Up to 12'	Up to 10' →		Up to 8-ft. hts. →			Up to 6-ft. heights →			
	4x6		Up to 12' →		Up to 10-ft. hts. →			Up to 8-ft. heights →			
	6x6				Up to 12-ft. heights →						

¹Based on 40 p.s.f. deck live load plus 10 p.s.f. dead load. Grade is Standard and Better for 4- x 4-inch posts and No. 1 and Better for larger sizes.

²Group 1 — Douglas-fir-larch and southern pine; Group 2 — Hem-fir and Douglas-fir south; Group 3 — Western pines and cedars, redwood, and spruces.

³Example: If the beam supports are spaced 8 feet, 6 inches, on center and the posts are 11 feet, 6 inches, on center, then the load area is 98. Use next larger area 108.

ture or component are in great measure dependent upon the fastenings used to hold the parts together. The most common wood fasteners are nails and spikes, followed by screws, lag screws, bolts, and metal connectors and straps of various shapes. An important factor for outdoor use of fasteners is the finish selected. Metal fasteners should be rust-proofed in some manner or made of rust-resistant metals. Galvanized and cadmium plated finishes are the most common. Aluminum, stainless steel, copper, brass, and other rust-proof fasteners are also satisfactory. The most successful for such species as redwood are hot-dip galvanized, aluminum, or stainless steel fasteners. These prevent staining of the wood under exposed conditions. A rusted nail, washer, or bolt head is not only unsightly but difficult to remove

and replace. They are often a factor in the loss of strength of the connection.

Among the nails, smooth shank nails often lose their holding power when exposed to wetting and drying cycles. The best assurance of a high retained withdrawal resistance is the use of a deformed shank nail or spike. The two general types most satisfactory are (a) the annular grooved (ring shank) and (b) the spirally grooved nail (fig. 6). The value of such a nail or spike is its capacity to retain withdrawal resistance even after repeated wetting and drying cycles. Such nails should be used for the construction of exposed units if screws, lag screws, or bolts are not used.

The following tabulation lists the sizes of common nails ordinarily used in construction of outdoor wood structures. (Note: Sinker and

Table 3. — Minimum beam sizes and spans¹

Species group ²	Beam size (in.)	Spacing between beams ³ (ft.)									
		4	5	6	7	8	9	10	11	12	
1	4x6	Up to 6-ft. spans									
	3x8	Up to 8-ft.		Up to 7'	Up to 6-ft. spans						
	4x8	Up to 10'	Up to 9'	Up to 8'	Up to 7-ft.		Up to 6-ft. spans				
	3x10	Up to 11'	Up to 10'	Up to 9'	Up to 8-ft.		Up to 7-ft.	Up to 6-ft.			
	4x10	Up to 12'	Up to 11'	Up to 10'	Up to 9-ft.		Up to 8-ft.	Up to 7-ft.			
	3x12		Up to 12'	Up to 11'	Up to 10'	Up to 9-ft.		Up to 8-ft. spans			
	4x12			Up to 12-ft.	Up to 11'	Up to 10-ft.	Up to 9-ft.				
	6x10				Up to 12'	Up to 11'	Up to 10-ft. spans				
	6x12					Up to 12-ft. spans					

2	4x6	Up to 6-ft.								
	3x8	Up to 7-ft.		Up to 6-ft.						
	4x8	Up to 9'	Up to 8'	Up to 7-ft.	Up to 6-ft.					
	3x10	Up to 10'	Up to 9'	Up to 8'	Up to 7-ft.		Up to 6-ft. spans			
	4x10	Up to 11'	Up to 10'	Up to 9'	Up to 8-ft.		Up to 7-ft. spans		Up to 6'	
	3x12	Up to 12'	Up to 11'	Up to 10'	Up to 9'	Up to 8-ft.	Up to 7-ft. spans			
	4x12		Up to 12'	Up to 11'	Up to 10-ft.		Up to 9-ft.	Up to 8-ft.		
	6x10			Up to 12'	Up to 11'	Up to 10-ft.		Up to 9-ft. spans		
	6x12				Up to 12-ft. spans			Up to 11-ft.	Up to 10'	

3	4x6	Up to 6'							
	3x8	Up to 7'	Up to 6'						
	4x8	Up to 8'	Up to 7'	Up to 6-ft.					
	3x10	Up to 9'	Up to 8'	Up to 7'	Up to 6-ft. spans				
	4x10	Up to 10'	Up to 9'	Up to 8-ft.		Up to 7-ft.	Up to 6-ft. spans		
	3x12	Up to 11'	Up to 10'	Up to 9'	Up to 8'	Up to 7-ft. spans		Up to 6-ft.	
	4x12	Up to 12'	Up to 11'	Up to 10'	Up to 9-ft.		Up to 8-ft.	Up to 7-ft.	
	6x10		Up to 12'	Up to 11'	Up to 10'	Up to 9-ft.		Up to 8-ft. spans	
	6x12			Up to 12-ft.		Up to 11-ft.		Up to 10-ft.	

¹ Beams are on edge. Spans are center to center distances between posts or supports. (Based on 40 p.s.f. deck live load plus 10 p.s.f. dead load. Grade is No. 2 or Better; No. 2, medium grain southern pine.)

² Group 1 — Douglas fir-larch and southern pine; Group 2 — Hem-fir and Douglas-fir south; Group 3 — Western pines and cedars, redwood, and spruces.

³ Example: If the beams are 9 feet, 8 inches apart and the species is Group 2, use the 10-ft. column; 3x10 up to 6-ft. spans, 4x10 or 3x12 up to 7-ft. spans, 4x12 or 6x10 up to 9-ft. spans, 6x12 up to 11-ft. spans.

Table 4. — Maximum allowable spans for deck joists¹

Species group ²	Joist size (inches)	Joist spacing (inches)		
		16	24	32
1	2x6	9'-9"	7'-11"	6'-2"
	2x8	12'-10"	10'-6"	8'-1"
	2x10	16'-5"	13'-4"	10'-4"
2	2x6	8'-7"	7'-0"	5'-8"
	2x8	11'-4"	9'-3"	7'-6"
	2x10	14'-6"	11'-10"	9'-6"
3	2x6	7'-9"	6'-2"	5'-0"
	2x8	10'-2"	8'-1"	6'-8"
	2x10	13'-0"	10'-4"	8'-6"

¹Joists are on edge. Spans are center to center distances between beams or supports. Based on 40 p.s.f. deck live loads plus 10 p.s.f. dead load. Grade is No. 2 or Better; No. 2 medium grain southern pine.

²Group 1 — Douglas-fir-larch and southern pine; Group 2 — Hem-fir and Douglas-fir south; Group 3 — Western pines and cedars, redwood, and spruces.

Table 5. — Maximum allowable spans for spaced deck boards¹

Species group ²	Maximum allowable span (inches) ³					
	Laid flat				Laid on edge	
	1 x 4	2 x 2	2 x 3	2 x 4	2 x 3	2 x 4
1	16	60	60	60	90	144
2	14	48	48	48	78	120
3	12	42	42	42	66	108

¹These spans are based on the assumption that more than one floor board carries normal loads. If concentrated loads are a rule, spans should be reduced accordingly.

²Group 1 — Douglas-fir-larch and southern pine; Group 2 — Hem-fir and Douglas-fir south; Group 3 — Western pines and cedars, redwood, and spruces.

³Based on Construction grade or Better (Select Structural, Appearance, No. 1 or No. 2).

Table 6. — Recommended grades, minimum thicknesses, and nailing details for various spans and species groups of plywood decking¹

Plywood species group ²	Panel thicknesses in inches ^{3 4}			
	For maximum spacings between supports (inches)			
	16	20	24	32 or 48
1	1/2	5/8	3/4	1-1/8
2 & 3	5/8	3/4	7/8	1-1/8
4	3/4	7/8	1	⁵

¹ Recommended thicknesses are based on Underlayment Exterior (C-C Plugged) grade. Higher grades, such as A-C or B-C Exterior, may be used. 19/32-inch plywood may be substituted for 5/8-inch and 23/32-inch for 3/4-inch.

² Plywood species groups are approximately the same but not identical to those shown for lumber in tables 2-5. Therefore, in selecting plywood, one should be guided by the group number stamped on the panel.

³ Edges of panels shall be T&G or supported by blocking.

⁴ Nailing details: Size — 6^d deformed shank nails, except 8^d for 7/8-inch or 1-1/8-inch plywood on spans 24 to 48 inches. Spacing — 6 inches along panel edges, 10 inches along intermediate supports (6 inches for 48-inch on center supports). Corrosion resistant nails are recommended where nail heads are to be exposed. Nails should be set 1/16 inch (1/8 inch for 1 1/8-inch plywood).

⁵ Not permitted.

cooler nails are one-eighth to one-fourth inch shorter.)

Nail size (penny)	Nail length (inches)
4	1-1/2
6	2
7	2-1/4
8	2-1/2
10	3
12	3-1/4
16	3-1/2
20	4
30	4-1/2
40	5
50	5-1/2
60	6

Usually classed as spikes

Wood screws may be used if cost is not a factor in areas where nails are normally specified. Wood screws retain their withdrawal resistance to a great extent under adverse conditions. They are also superior to nails when end-grain fastening must be used. Because of their larger diameter, screw length need not be as great as a deformed shank nail. The flathead screw is best for exposed surfaces because it does not extend beyond the surface (fig. 7), and the oval head protrudes less than the round head screw. This is an important factor in the construction of tables and benches. The use of a lead hole about three-fourths the diameter of the screw is good practice especially in the denser woods to prevent splitting. Screws should always be turned in their full length and not driven part way. The new variable speed

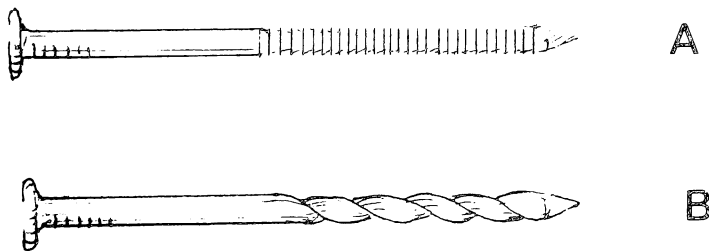

Figure 6. — Deformed shank nails. A — annular grooved (ring shank); B — spirally grooved.

drills (with a screwdriver) are excellent for applying screws.

Lag screws are commonly used to fasten a relatively thick, such as 2- by 6-inch, member to a thicker member (3-or-more-inch) where a through bolt cannot be used. Lead holes must be used, and the lag screw turned in its entire length. Use a large washer under the head. Lead holes for the threaded portion should be about two-thirds the diameter of the lag screw for the softer woods such as redwood or cedar, and three-fourths the diameter for the dense hardwoods and for such species as Douglas-fir. The lead hole for the unthreaded shank of the lag screw should be the same diameter as that of the lag screw.

Bolts are one of the most rigid fasteners in a simple form. They may be used for small connections such as railings-to-posts and for large members when combined with timber connectors. The two types of bolts most commonly used in light frame construction are the carriage bolt and the machine bolt (fig. 8). When obtainable, the step bolt is preferred over the carriage bolt because of its larger head diameter.

The carriage bolt is normally used without a washer under the head. A squared section at the bolt head resists turning as it is tightened. Washers should always be used under the head of the machine bolt and under the nut of both types. Bolt holes should be the exact diameter of the bolt. When a bolt-fastened member is loaded,

such as a beam to a post, the bearing strength of the wood under the bolt is important as well as the strength of the bolt. A larger diameter bolt or several smaller diameter bolts may be used when the softer woods are involved. Crushing of wood under the head of a carriage bolt or under the washer of any bolt should always be avoided. The use of larger washers and a washer under the carriage bolt head is advisable when the less dense wood species are used.

For connections involving specific design in large members with split ring and similar connectors, the 1966 Timber Construction Manual of the American Institute of Timber Construction (1) or the Forest Products Laboratory Wood Handbook (9) should be consulted.

Miscellaneous fastening methods in addition to the nail, screw, and bolt are also used for fastening wood members together, or to other materials. Although split ring connectors and similar fasteners are normally used for large beams or trusses, other connectors may be used to advantage in the construction of a wood deck. These include metal anchors for connecting posts to concrete footings; angle iron and special connectors for fastening posts to beams; joist hangers and metal strapping for fastening joists to beams; and others. While research has not advanced far enough as yet, the new mastic adhesives are showing promise for field assembly of certain wood members. Such materials used alone or with metal fasteners will likely result in longer-lived connections.

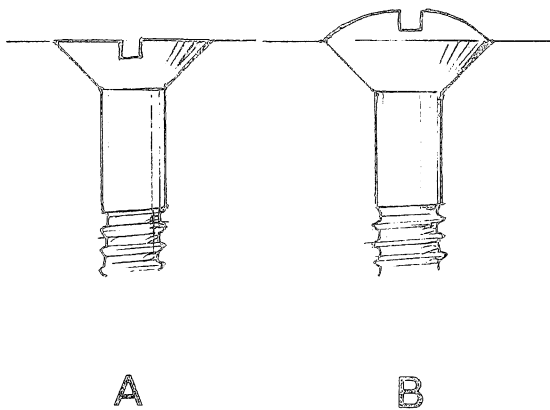

Figure 7. — Wood screws. A — flat head; B — oval head.

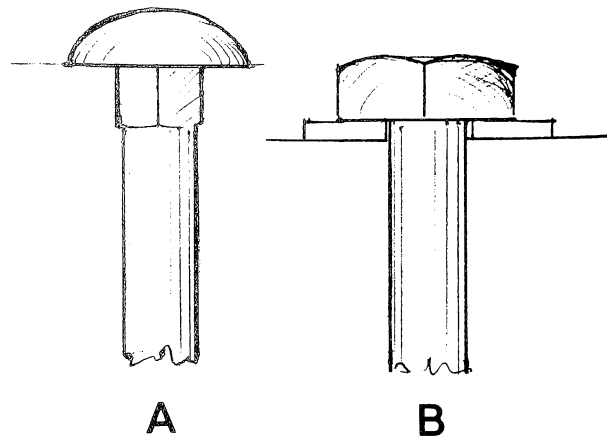

Figure 8. — Bolts. A — carriage; B — machine.

General Rules for Deck Construction

Our experience with exposed deck construction can be summarized in the following general guides for the use of wood and fasteners in outdoor decks.

Guides for Fastener Use

1. Use non-staining fasteners.
2. Always fasten a thinner member to a thicker member (unless clinched nails are used).
 - (a) A nail should be long enough to penetrate the receiving member a distance twice the thickness of the thinner member but not less than 1-1/2 inches (i.e., for a 3/4-inch board, the nail should penetrate the receiving member 1-1/2 inches. Use at least a 7-penny nail).
 - (b) A screw should be long enough to penetrate the receiving member at least the thickness of the thinner (outside) member but with not less than a 1-inch penetration (i.e., fastening a 3/4-inch member to a 2 by 4 would require a 1-3/4-inch-long screw).
3. To reduce splitting of boards when nailing —
 - (a) Blunt the nail point.
 - (b) Pre-drill (three-fourths of nail diameter).
 - (c) Use smaller diameter nails and a greater number.
 - (d) Use greater spacing between nails.
 - (e) Stagger nails in each row.
 - (f) Place nails no closer to edge than one-half of the board thickness and no closer to end than the board thickness.
 - (g) In wide boards (8 inches or more), do not place nails close to edge.
4. Use minimum of two nails per board — i.e., two nails for 4- and 6-inch widths and three nails for 8- and 10-inch widths.
5. Avoid end grain nailing. When unavoidable, use screws or side grain wood cleat adjacent to end grain member (as a post).
6. Lag screw use —
 - (a) Use a plain, flat washer under the head.
 - (b) Use lead hole and turn in full distance; do not overturn.
 - (c) Do not countersink (reduces wood section).
7. Bolt use —
 - (a) Use flat washers under nut and head of machine bolts and under nut of carriage bolt. In softer woods, use larger washer under carriage bolt heads.
 - (b) Holes to be exact size of bolt diameter.

Guides for Outdoor Wood Use

1. When a wide member is required, use edge grain boards, as they shrink, swell, and cup less than flat grain boards during moisture changes.
2. Do not use wood in direct contact with soil unless members are pressure treated.
3. Provide clearance of wood members (fences, posts, etc.) from plant growth and ground to minimize high moisture content. Bottoms of posts, when supported by piers for example, should be 6 inches above the grade.

4. Use forms of flat members which provide natural drainage (a sloped top of a cap rail, for example).
5. Use rectangular sections with width and thickness as nearly equal as possible, i.e.,

- 3 by 4 instead of 2 by 6.
6. Dip all ends and points of fabrication in a water-repellent preservative treatment prior to placement.

Figure 9. — Decks expand living areas on steep hillsides with little disturbance of the ground.



Deck Construction

Site Preparation

Grading and drainage. — Site preparation for construction of a wood deck is often less costly than that for a concrete terrace. When the site is steep, it is difficult to grade and to treat the backslopes in preparing a base for the concrete slab. In grading the site for a wood deck, one must normally consider only proper drainage, disturbing the natural terrain as little as possible. Grading should be enough to insure water runoff, usually just a minor leveling of the ground (fig. 9).

Often, absorption of the soil under an open deck with spaced boards will account for a good part of a moderate rainfall. If the deck also serves as a roof for a garage, carport, or living area below, drainage should be treated as a part of the house roof drainage, whether by gutters, downspouts, or drip and drain pockets at the ground level. In such cases, some form of drainage may be required to carry water away from the site and prevent erosion. This can usually be accomplished with drain tile laid in a shallow drainage ditch (fig. 10). Tile should be spaced and joints covered with a strip of asphalt felt before the trench is filled. The tile can lead to a dry well or to a drainage field beyond the site. Perforated cement or plastic tile is also available for this use.

Weed and growth control. — There may also be a need for control of weed growth beneath the deck. Without some control or deterrent, such growth can lead to high moisture content of wood members and subsequent decay hazards where decks are near the grade. Common methods for such control consist of (a) the application of a weed killer to the plants or (b) the use of a membrane such as 4- or 6-mil polyethylene or 30-pound asphalt saturated felt.

Such coverings should be placed just before the deck boards are laid. Stones, bricks, or other permanent means of anchoring the membranes in place should be used around the perimeter and in any interior surface variations which may be present. A few holes should be punched in the covering so that a good share of the rain will not run off and cause erosion.

Footings

Some type of footing is required to support the posts or poles which transfer the deck loads to the ground. In simplest form, the bottom of a treated pole and the friction of the earth around the pole provide this support. More commonly, however, some type of masonry, usually concrete, is used as a footing upon which the poles or posts rest. Several footing systems are normally used, some more preferred than others.

Footings for posts below grade. — Footings required for support of vertical members such as wood poles or posts must be designed to carry the load of the deck superstructure (11). In a simple form, the design includes the use of pressure-treated posts or poles embedded to a depth which provides sufficient bearing and rigidity (fig. 11). This may require a depth of 3 to 5 feet or more, depending on the exposed pole height and applied loads. This type is perhaps more commonly used for pole structures such as storage sheds or barns. In areas where frost is a problem, such as in the Northern States, an embedment depth of 4 feet is commonly a minimum. But a lesser depth may be adequate in warmer climates. Soil should be well-tamped around the pole.

Concrete footings below the surface are normally used for treated posts or poles. Two

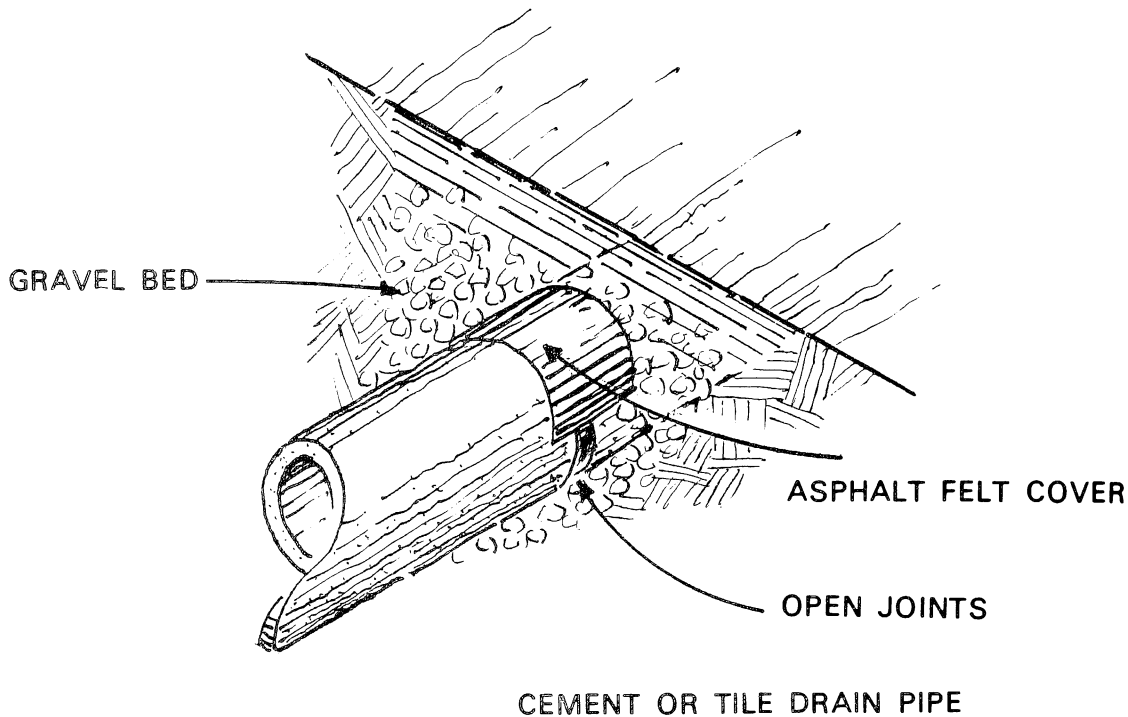

Figure 10. — Drain tile.

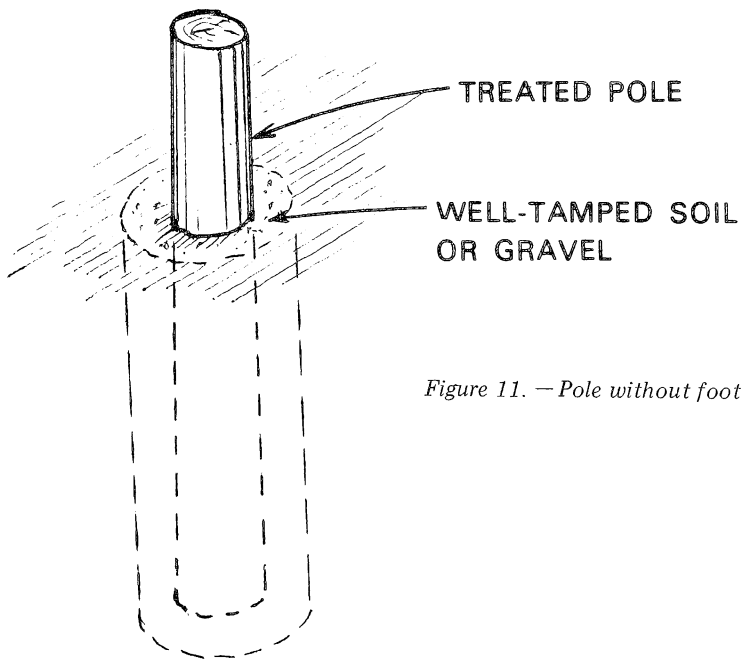

Figure 11. — Pole without footing.

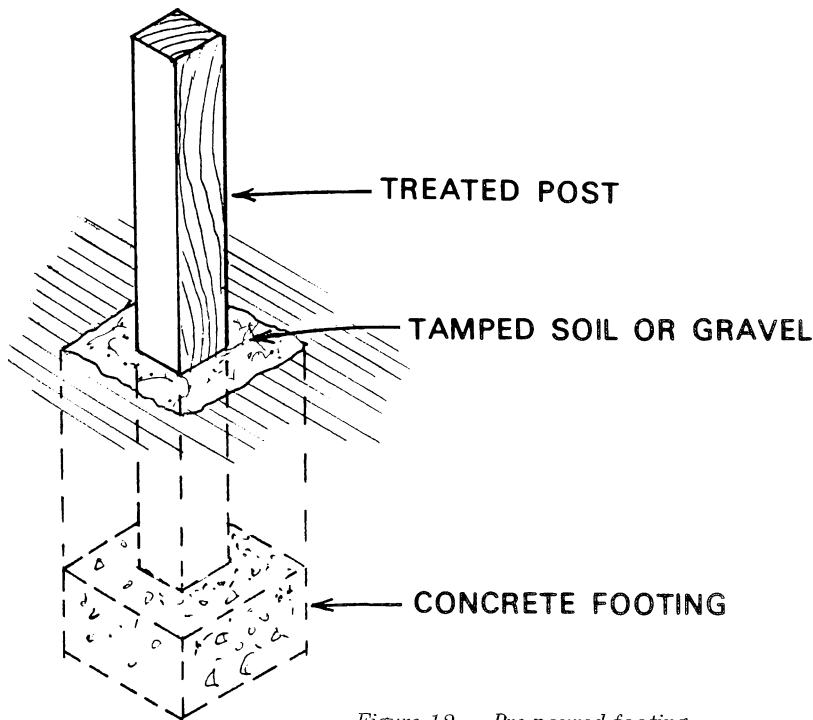

Figure 12. — Pre-poured footing.

such types may be used. The first consists of a pre-poured footing upon which the wood members rest (fig. 12). Embedment depth should be only enough to provide lateral resistance, usually 2 to 3 feet. The exception is in cold climates where frost may penetrate to a depth of 4 feet or more. Minimum size for concrete footings in normal soils should be 12 by 12 by 8 inches. Where spacing of the poles is over about 6 feet, 20 by 20 by 10 inches or larger sizes are preferred. However, soil capacities should be determined before design.

Another type of below-grade footing is the poured-in-place type shown in fig. 13. In such construction, the poles are pre-aligned, plumbed, and supported above the bottom of the excavated hole. Concrete is then poured below and around the butt end of the pole. A minimum thickness of 8 inches of concrete below the bottom of the pole is advisable. Soil may be added above the concrete when necessary for protection in cold weather. Such foot-

ings do not require tamped soil around the pole to provide lateral resistance. All poles or posts embedded in the soil should always be pressure treated for long life.

Footings for posts above grade. — Footings or footing extensions for posts which are entirely exposed above the grade are poured so the top is at least 6 inches above the surrounding soil. When the size of the footing is greater than the post size (which is normal), a pedestal-type extension is often used (fig. 14A). The bottom of the footing should be located below frost level which may require a long pier-type pedestal. A wood form can be used when pouring pedestal (fig. 14B). Made in this manner with extension on each side, it is easily demountable. The use of form nails (double-head) is also satisfactory. Bolts, angle irons, or other post anchorage should be placed when pouring, and anchor bolts or other bond bars should extend into the footing for positive anchorage against uplift.

Post-to-Footing Anchorage

The anchorage of supporting posts to footings with top surfaces above grade is important as they should not only resist lateral movement but also uplift stresses which can occur during periods of high winds. These anchorages should be designed for good drainage and freedom from contact of the end-grain of the wood with wet concrete. This is advisable to prevent decay or damage to the bottom of the wood post. It is also important that the post ends be given a dip treatment of water-repellent preservative. Un-

fortunately, such features are sometimes lacking in post anchorage. As recommended for nails, screws, bolts, and other fastenings, all metal anchors should be galvanized or treated in some manner to resist corrosion.

Poor design includes an embedded wood block as a fastening member with the post toenailed in place (fig. 15A). This is generally poor practice even when the block has been pressure treated, as moisture can accumulate in the post bottom.

Another poor practice is shown in fig. 15B.

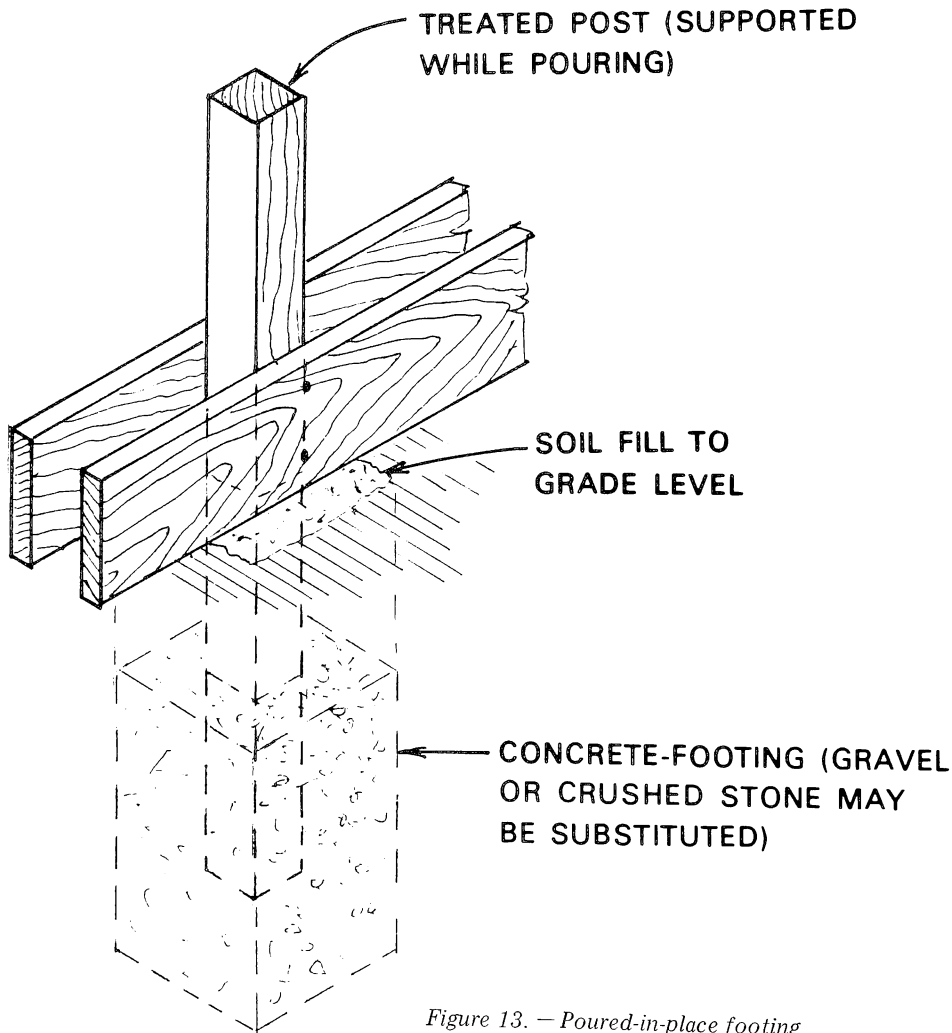
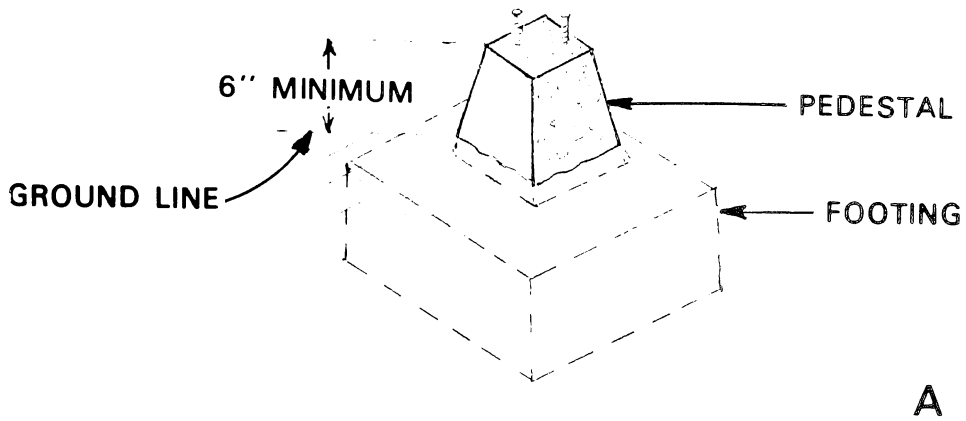
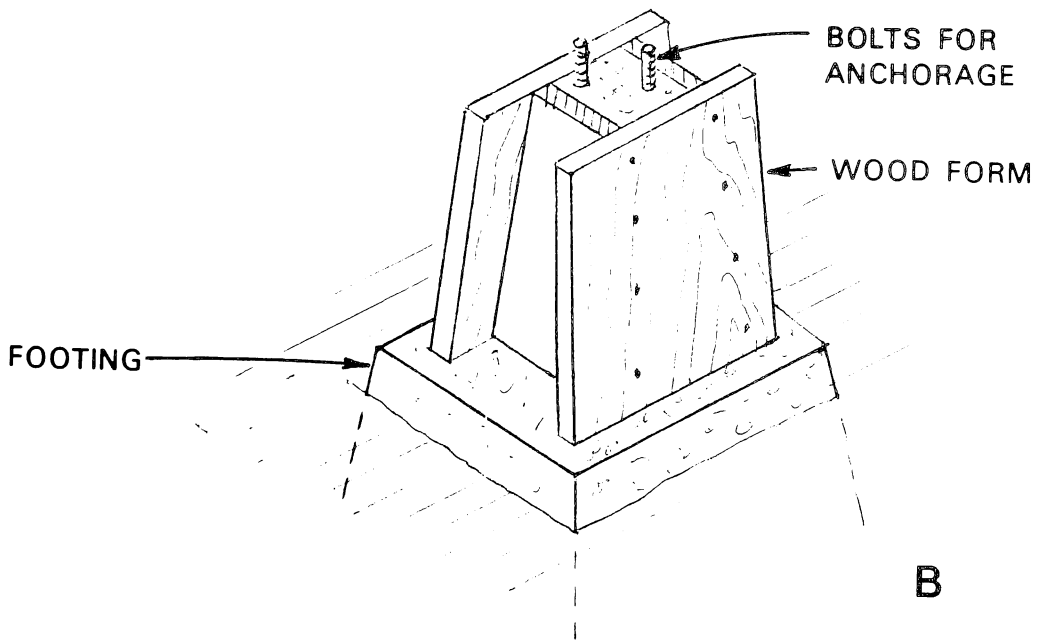

Figure 13. — Poured-in-place footing.



A



B

Figure 14. — Pedestal footing extension. A — pedestal for post; B — form used for pouring.

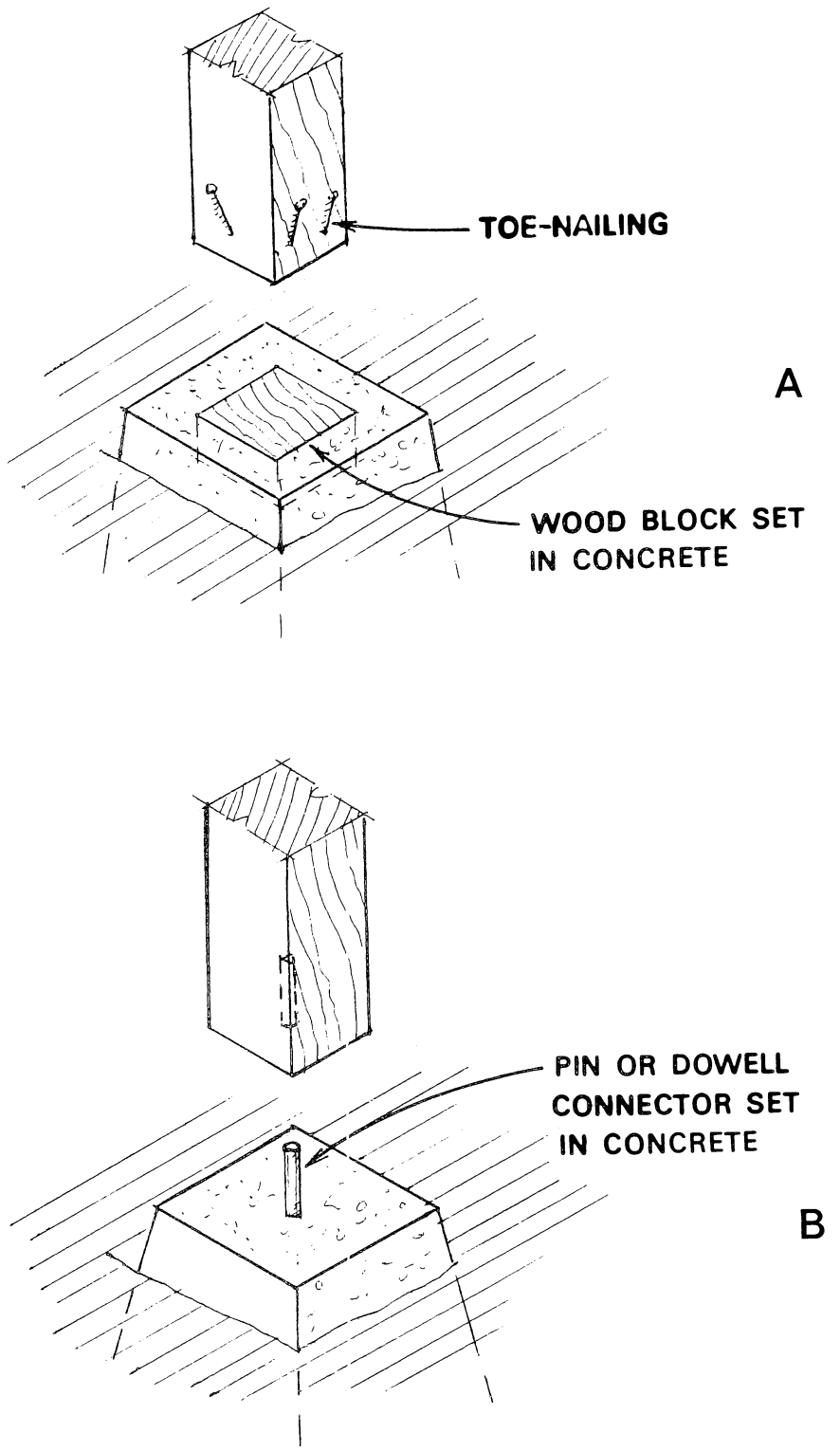

Figure 15. — Post-to-footing anchorage. A and B — poor practice.

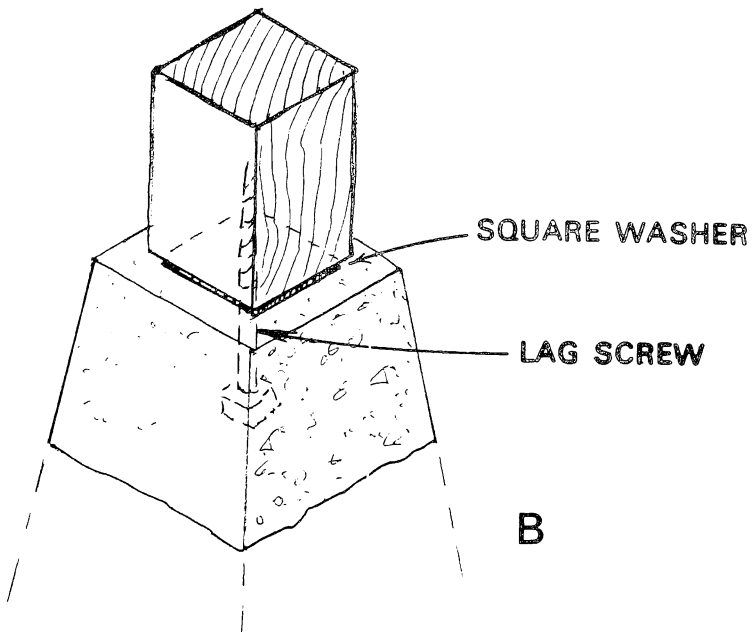
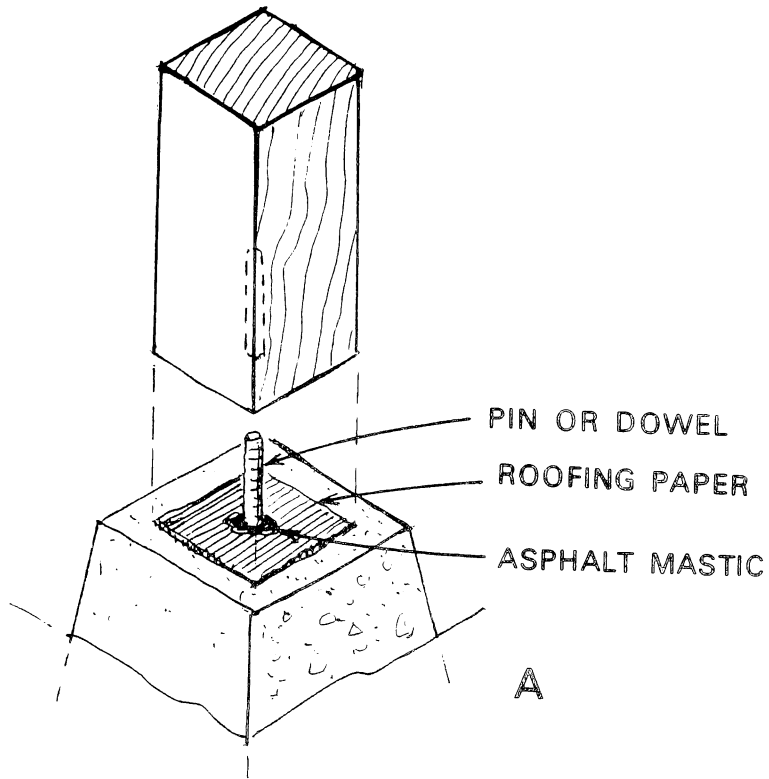

Figure 16. — Post-to-footing anchorage. A and B — improved practice.

The bottom of the post is in direct contact with the concrete footing which can result in moisture absorption. Although the pin anchor resists lateral movement, it has little uplift resistance.

Better design of fig. 16A is a slight improvement over fig. 15B as a heavy roofing paper and roofing mastic prevents the bottom of the post from absorbing moisture from the concrete footing.

A better system of anchoring small 4- by 4-inch posts is shown in fig. 16B. In such anchorage, a galvanized lag screw is turned into the bottom of the post with a large square washer (about 3- by 3- by 1/4-inch thick for a 4- by 4-inch post) placed for a bearing area. Post is then anchored into a grouted pre-drilled hole or supported in place while concrete is poured. The washer prevents direct contact with the concrete and prevents moisture wicking into the bottom of the post, and the lag screw head provides some uplift resistance.

Good design is an anchorage system for supporting small posts, beams, stair treads, and similar members, utilizing a small steel pipe (galvanized or painted) with a pipe flange at each end (fig. 17A). A welded plate or angle iron can be substituted for the pipe flange (fig. 17B). The pipe flange or plate-to-post connection should be made with large screws or lag screws. The flange can be fastened to the post bottom and turned in place after the concrete is poured (fig. 17A). When an angle iron is used, the entire assembly is poured in place. A good anchor for beams used in low decks is shown in fig. 17C.

Other post anchors can be obtained (or made up) for anchoring wood posts to a masonry base. Such anchors are normally used for solid 4- by 4-inch or larger posts. All are designed to provide lateral as well as uplift resistance. Some means such as a plate or supporting angle is provided to prevent contact of the post with the concrete, thus reducing the chances for decay. All holes drilled into posts for the purpose of anchorage should be flushed with a water-repellent preservative to provide protection. An oil can is a good method of applying such materials.

One type of anchor is shown in fig. 18. Post support is supplied by the anchor itself. This step-flange anchor is positioned while the con-

crete is being poured and should be located so that the bottom of the post is about 2 inches above the concrete.

Another type of anchor for solid posts consists of a heavy metal strap shaped in the form of a "U" with or without a bearing plate welded between (fig. 19). These anchors are placed as the concrete pier or slab is being poured. As shown in fig. 18, the post is held in place with bolts.

Fig. 20 illustrates one type of anchor that may be used with double posts. In this and similar cases, the anchor in the concrete is positioned during the pouring operation.

Beam-to-Post Connection

Beams are members to which the floor boards are directly fastened or which support a system of joists. Such beams must be fastened to the supporting posts. Beams may be single large or small members or consist of two smaller members fastened to each side of the posts. When a solid deck is to be constructed, the beams should be sloped at least 1 inch in 8 to 10 feet away from the house.

Single beams when 4 inches or wider usually bear on a post. When this system is used, the posts must be trimmed evenly so that the beam bears on all posts. Use a line level or other method to establish this alignment.

A simple but poor method of fastening a 4- by 4-inch post to a 4- by 8-inch beam, for example, is by toe-nailing (fig. 21A). This is poor practice and should be avoided. Splitting can occur which reduces the strength of the joint. It is also inadequate in resisting twisting of the beam.

A better system is by the use of a 1- by 4-inch lumber or plywood (Exterior grade) cleat located on two sides of the post (fig. 21B). Cleats are nailed to the beam and post with 7^d or 8^d deformed shank nails.

A good method of post-to-beam connection is by the use of a metal angle at each side (fig. 22A). A 3- by 3-inch angle or larger should be used so that fasteners can be turned in easily. Use lag screws to fasten them in place. A metal strap fastened to the beam and the post might also be used for single beams (fig. 22B). A 1/8- by 3-inch or larger strap, pre-formed to insure a good fit, will provide an adequate connection.

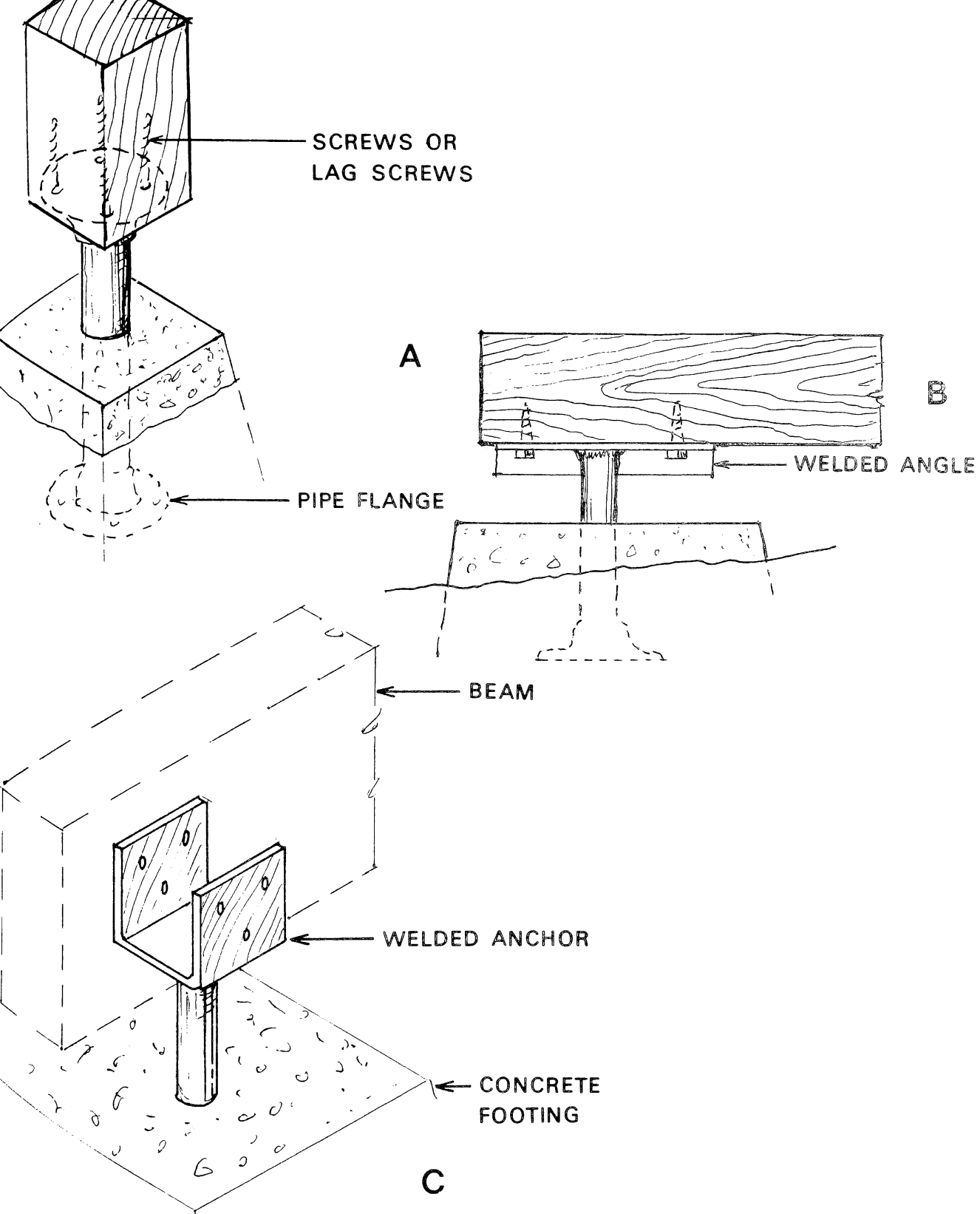

Figure 17. — Pipe and flange anchor. A — pipe flange; B — welded angle (low decks); C — saddle anchor for low decks.

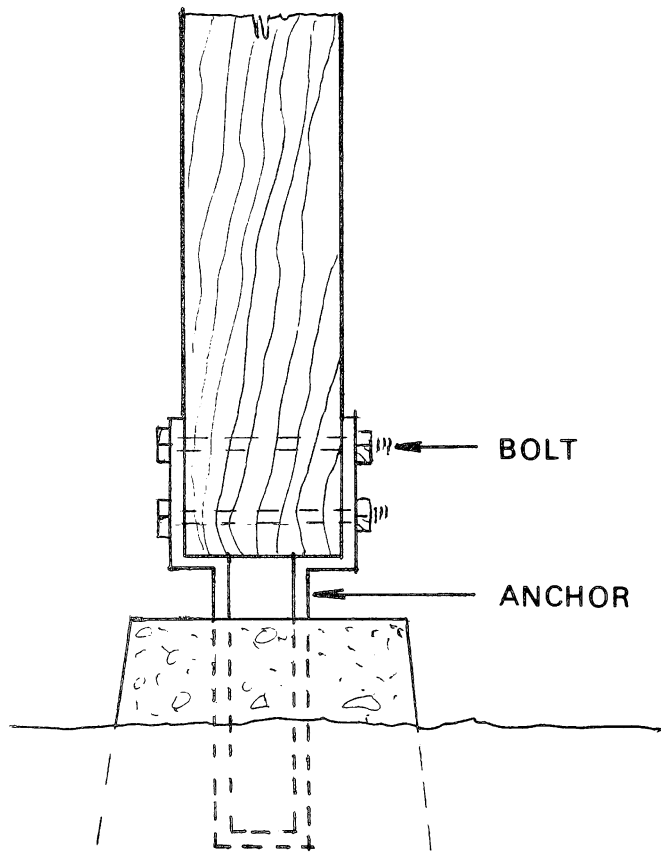

Figure 18. — Step-flange anchor.

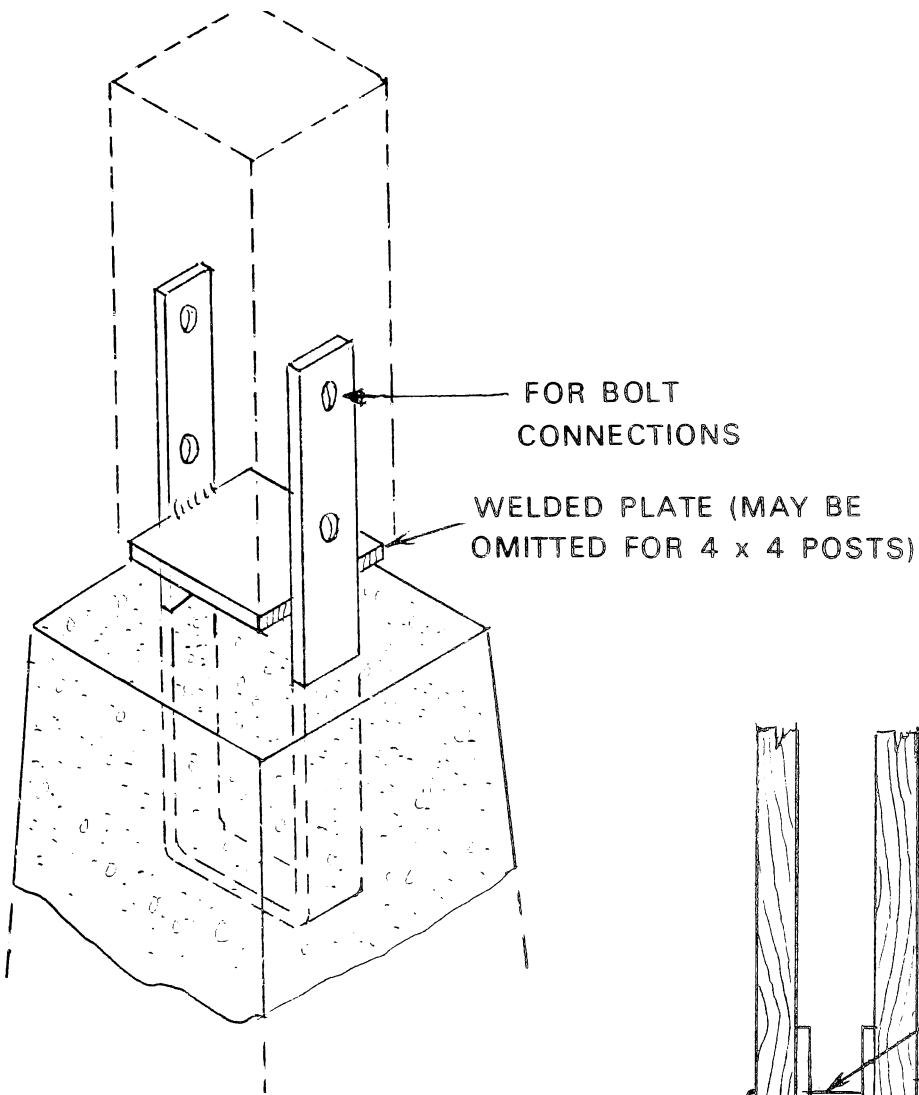

Figure 19. — Strap anchor.

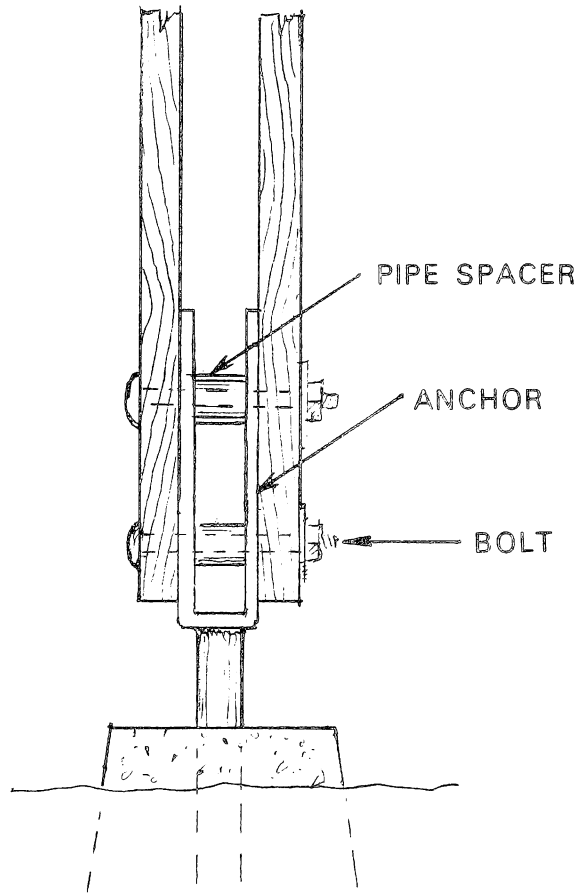

Figure 20. — Double post anchor (without bearing plate).

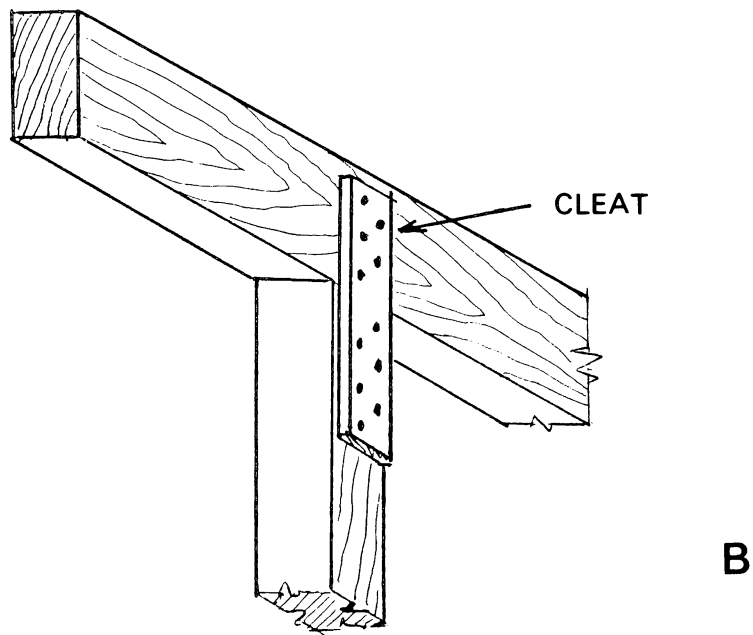
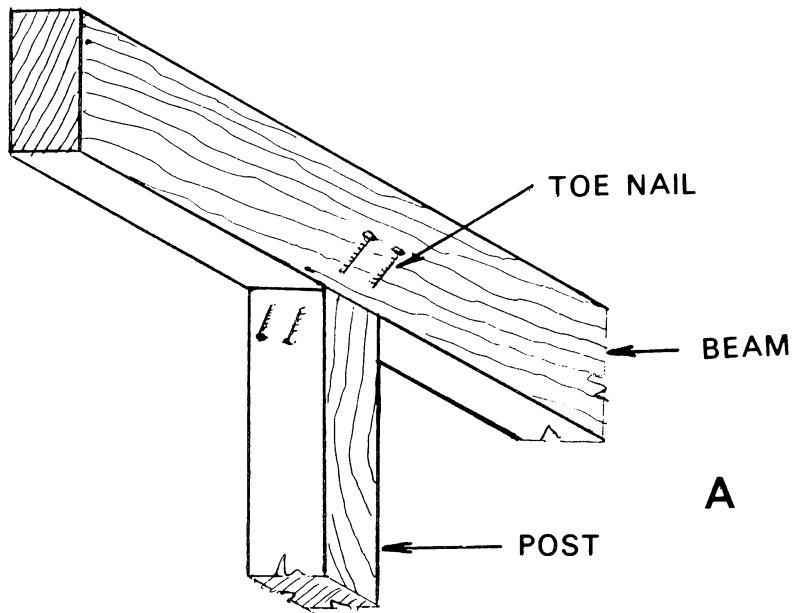

Figure 21.—Beam-to-post connection. A—*toe-nailing, a poor practice*; B—*better practice is to use cleat.*

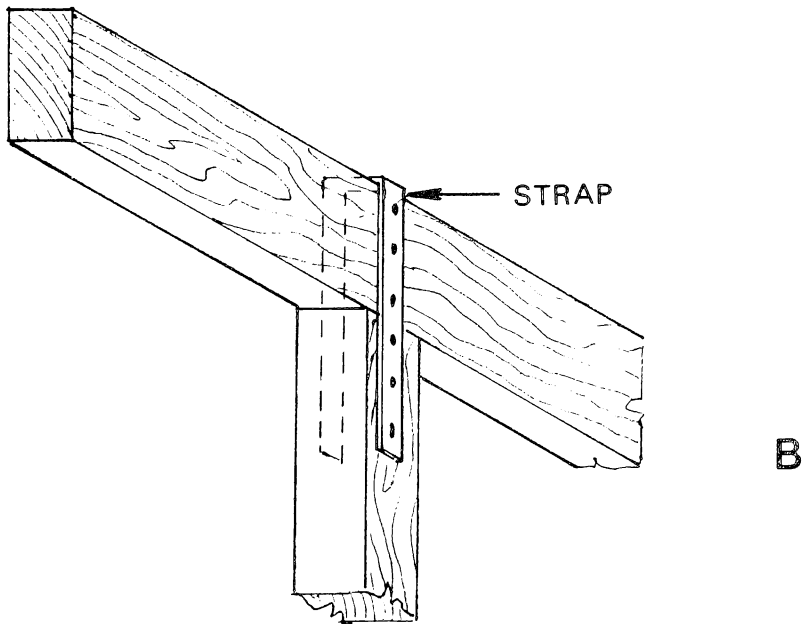
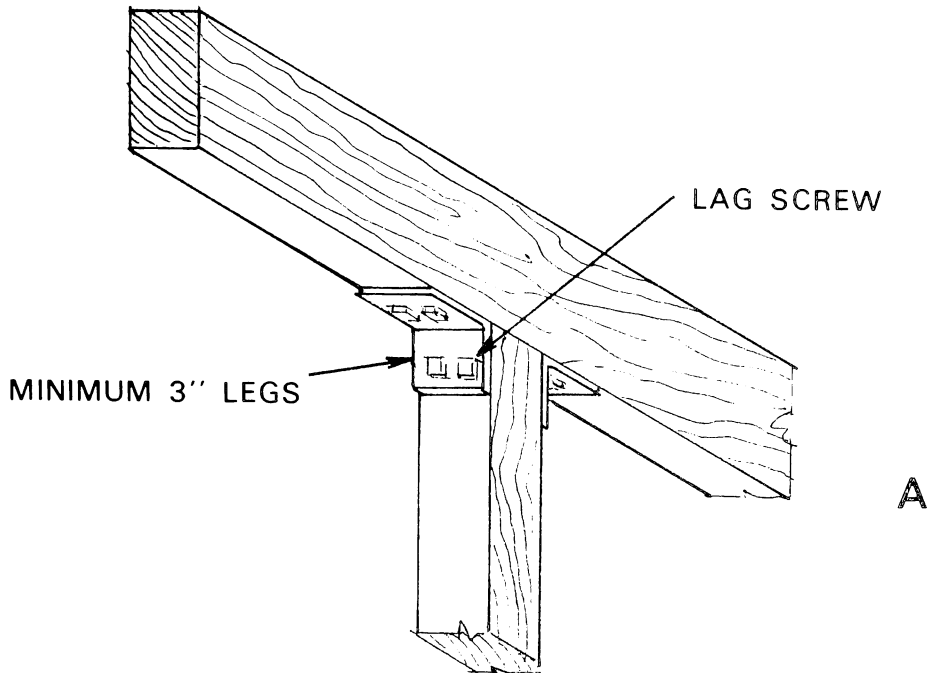

Figure 22. — Beam-to-post connection. Both A, angle iron, and B, strapping, are good methods.

Use 10^d deformed shank nails for the smaller members and 1/4-inch lag screws for larger members.

A good method of connection for smaller posts and beams consists of a sheet metal flange which is formed to provide fastening surfaces to both beam and post (fig. 23A). The flange is normally fastened with 8^d nails. To prevent splitting, nails should not be located too close to the end of the post. Upper edges of this connector can collect and retain moisture, but this weakness can be minimized somewhat by providing a small groove along the beam for the flange (fig. 23B).

When a double post is used, such as two 2- by 6-inch members, a single beam is usually placed between them. One method of terminating the post ends is shown in fig. 24A. This is not fully satisfactory as the end grain of the posts is exposed. Some protection can be had by placing asphalt felt or metal flashing over the joint. Fastening is done with bolts or lag screws. Another method of protection is by the use of cleats over the ends of the posts (fig. 24B).

Double or split beams are normally bolted to the top of the posts, one on each side (fig. 25A). As brought out previously, the load capacity of such a bolted joint depends on the bolt diameter, the number of bolts used, and the resistance of the wood under the bolts. Thus larger diameter bolts should be used to provide greater resistance for the less dense woods (i.e., 1/2-inch rather than 3/8-inch diameter). Notching the top of the beam as shown in fig. 25B provides greater load capacity. A piece of asphalt felt or a metal flashing over the joint will provide some protection for the post end.

Small single beams are occasionally used with larger dimension posts (i.e., 4- by 8-inch beam and 6- by 6-inch post). In such cases, one method of connection consists of bolting the beam directly to the supporting posts (fig. 26A). Some type of flashing should be used over the end of the post.

Another method of connecting smaller beams to larger posts is shown in fig. 26B. A short section of angle iron is used on each side of the post for anchorage and a wood cleat is

then placed to protect the exposed end grain of the larger post.

It is sometimes advantageous to use the post which supports the beam as a railing post. In such a design, the beam is bolted to the post which extends above the deck to support the railing members (fig. 26C).

Beam-and-Joist-to-House Connections

When the deck is adjacent to the house, some method of connecting beams or joists to the house is normally required. This may consist of supporting such members through (a) metal hangers, (b) wood ledgers or angle irons, or (c) utilizing the top of the masonry foundation or basement wall. It is usually good practice to design the deck so that the top of the deck boards are just under the sill of the door leading to the deck. This will provide protection from rains as well as easy access to the deck.

Beams. — One method of connecting the beam to the house consists of the use of metal beam hangers (fig. 27A). These may be fastened directly to a floor framing member such as a joist header or to a 2- by 8-inch or 2- by 10-inch member which has been bolted or lag-screwed to the house framing. Use 6-penny or longer nails or the short, large-diameter nails often furnished with commercial hangers for fastening. Hangers are available for all beams up to 6 by 14 inches in size. In new construction, beam pockets or spaces between floor framing headers can be provided for the deck beam support. Beams can also be secured to the house proper by bearing on ledgers which have been anchored to the floor framing or to the masonry wall with expansion shields and lag screws. The beam should be fastened to the ledger or to the house with a framing anchor or a small metal angle (fig. 27B).

Joists. — When joists of the deck are perpendicular to the side or end of the house, they are connected in much the same manner as beams except that fasteners are smaller. The use of a ledger lag-screwed to the house is shown in fig. 28A. Joists are toe-nailed to the ledger and the house (header or stringer joists) or fastened with small metal clips.

Joists can also be fastened by a 2- by 8-inch or 2- by 10-inch member (lag-screwed to the

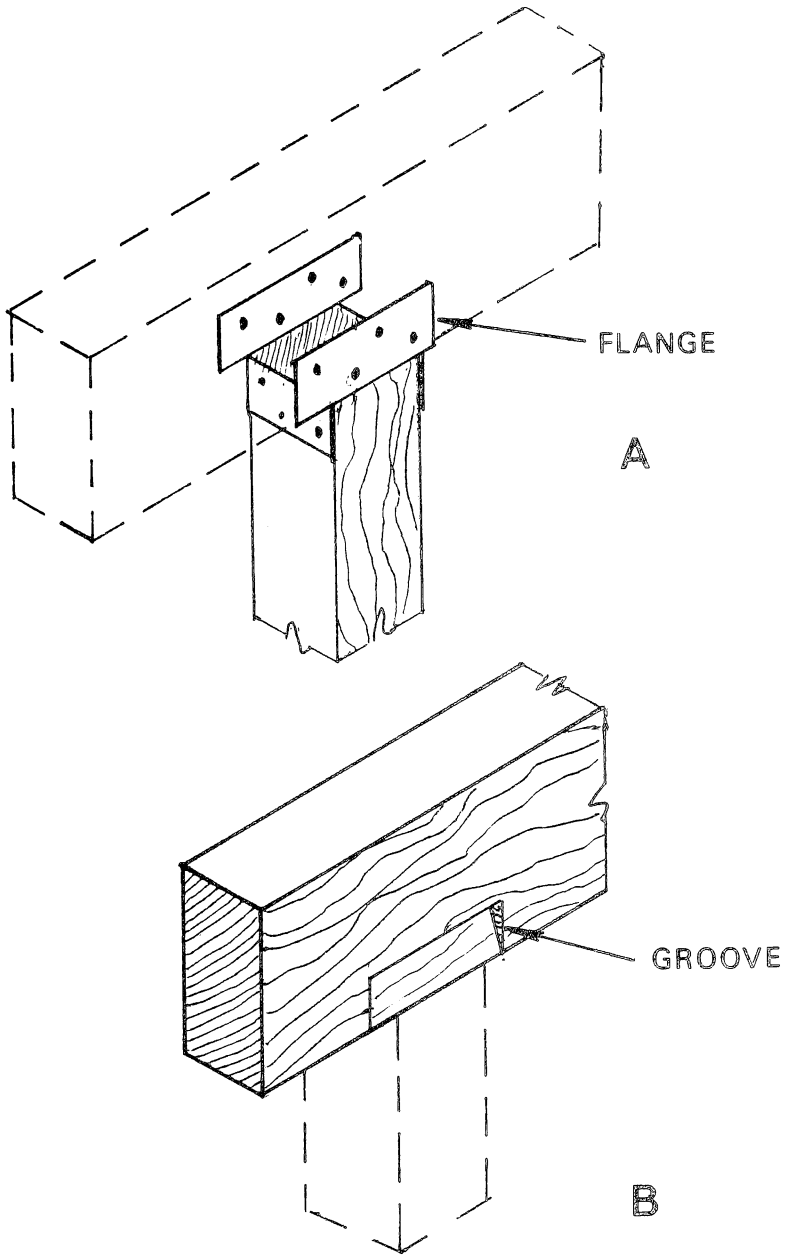

Figure 23. — Metal flange. A — flange in place; B — groove in beam.

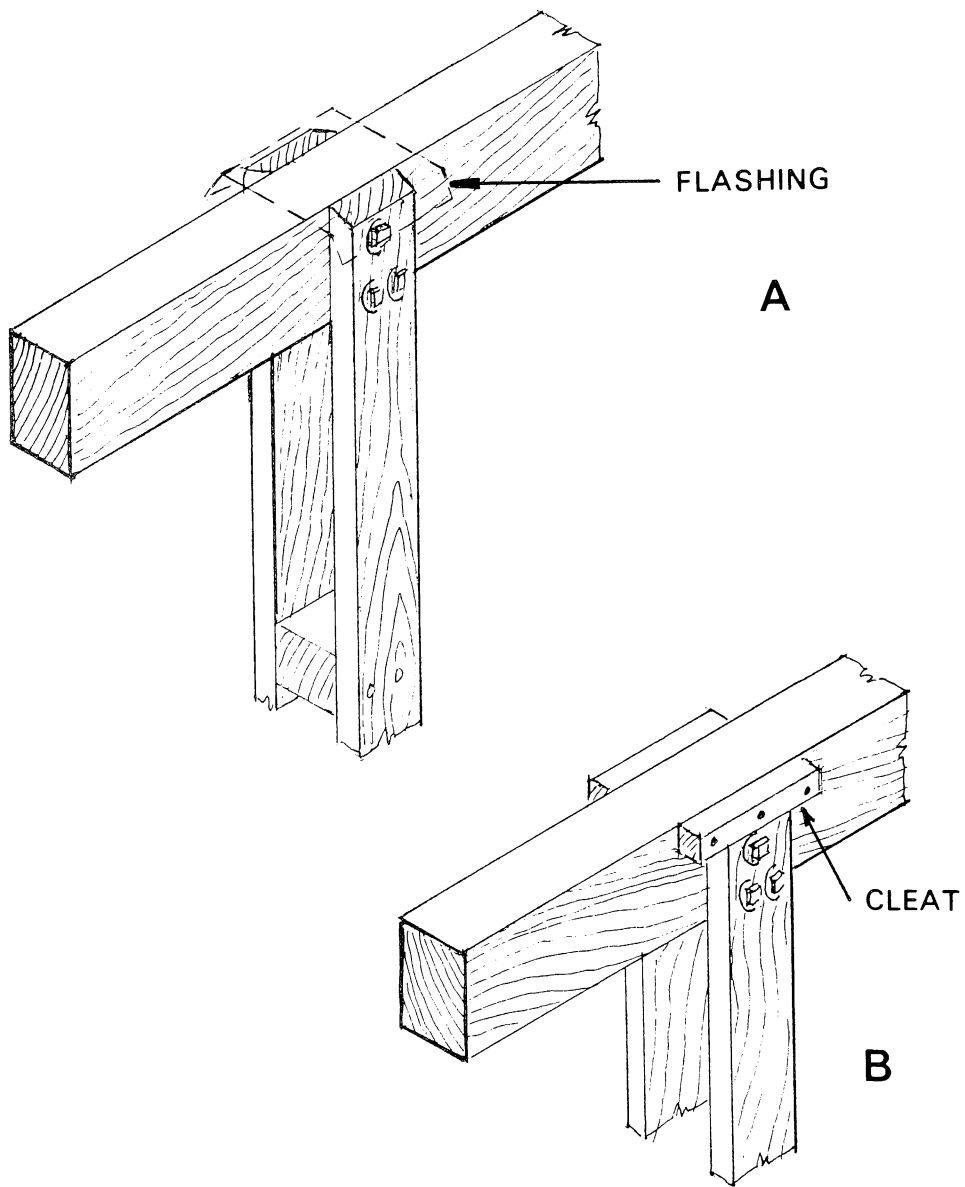

Figure 24. — Double post to beam. A — post connection with flashing; B — post connection with cleat.

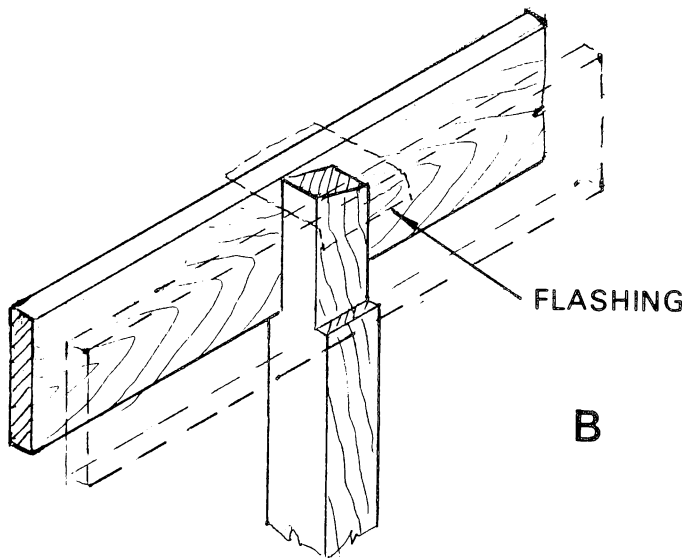
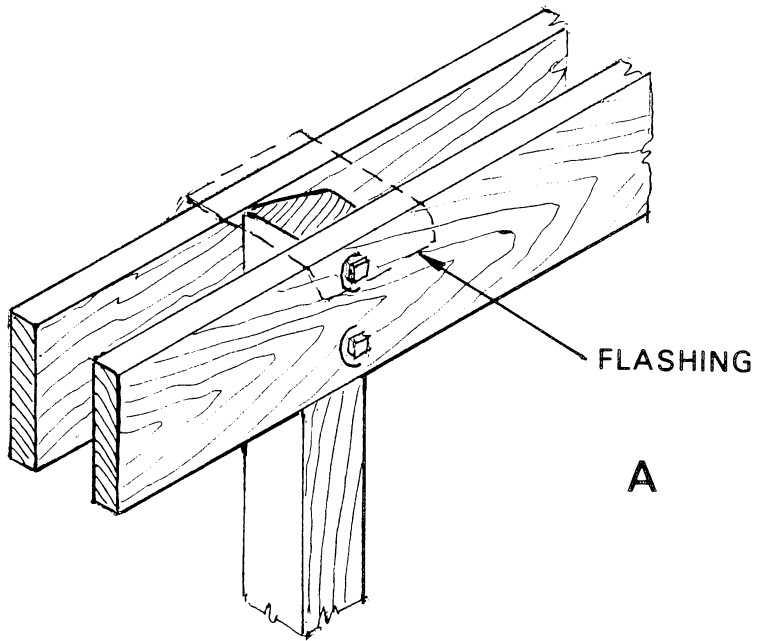

Figure 25. — Double beam to post. A — bolted joint with flashing; B — notched and bolted joint with flashing.

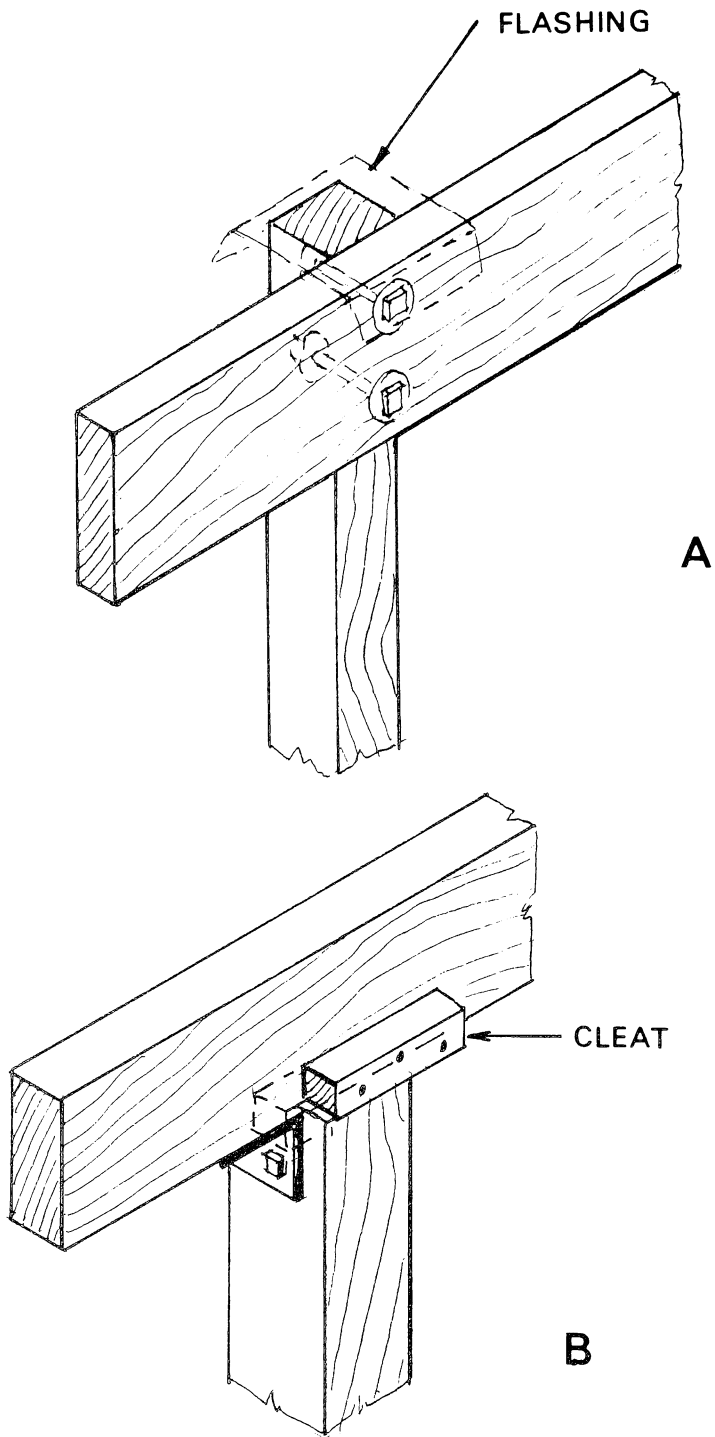
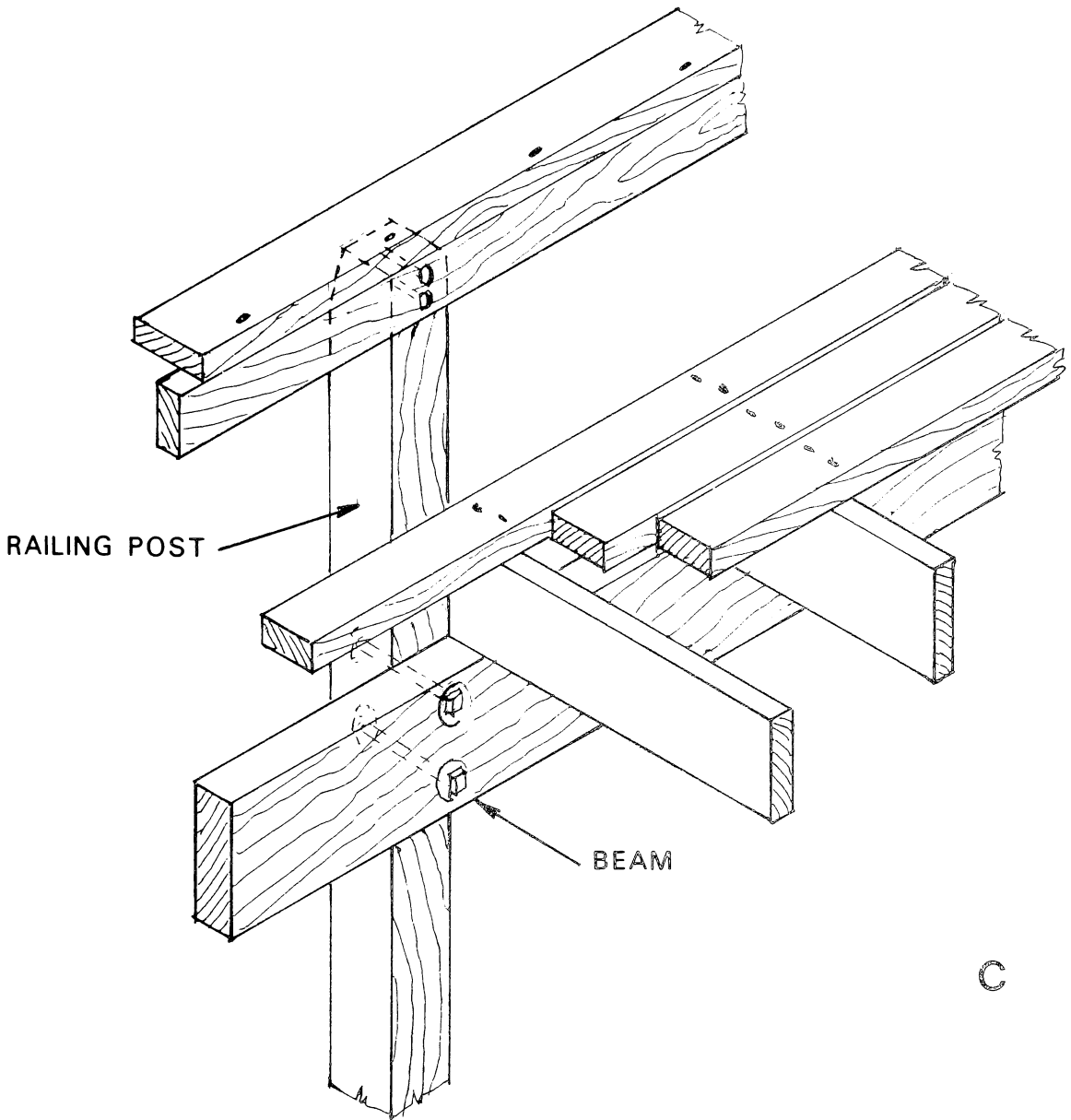

Figure 26. — Small beam to post. A — bolted connection; B — good connection for large post; C — extension of post for rail.



house) by means of joist hangers (fig. 28B). Six-penny nails or 1-1/4-inch galvanized roofing nails are used to fasten the hangers to the joist and to the header. When joists or beams are parallel to the house, no ledger or other fastening member is normally required (fig. 28C). If they are supported by beams, the beams, of course, are then connected to the house, as previously illustrated.

Bracing

On uneven sites or sloping lots, posts are often 5 or more feet in height. When the deck is free (not attached to the house), it is good practice to use bracing between posts to provide lateral resistance. Treated poles or posts embedded in the soil or in concrete footings usually have sufficient resistance to lateral forces,

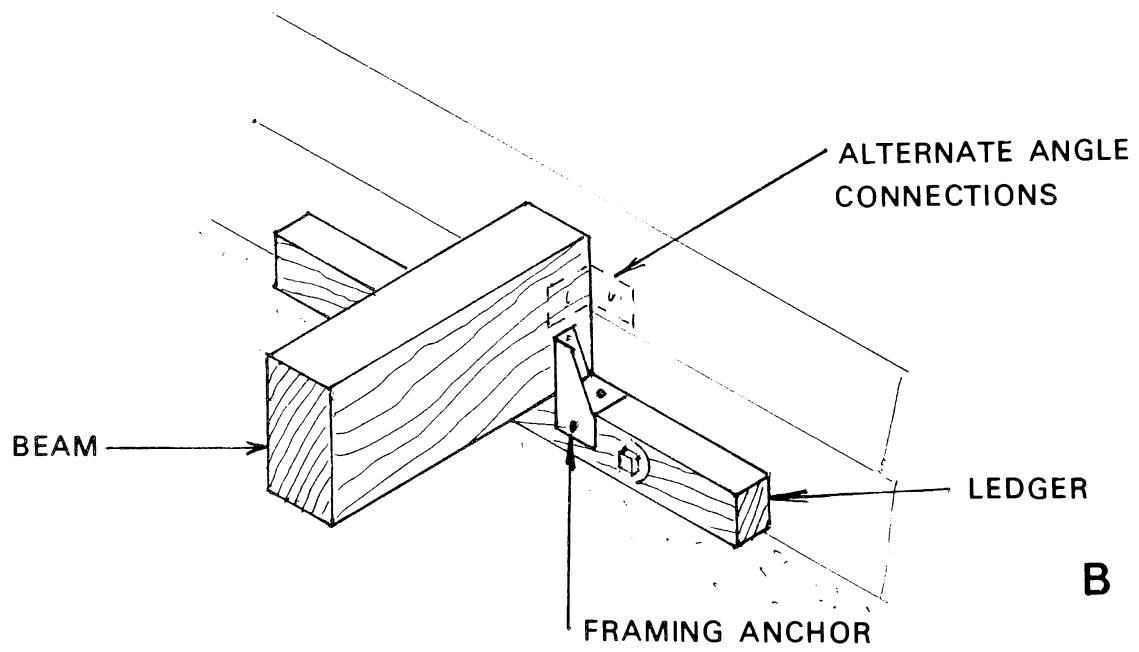
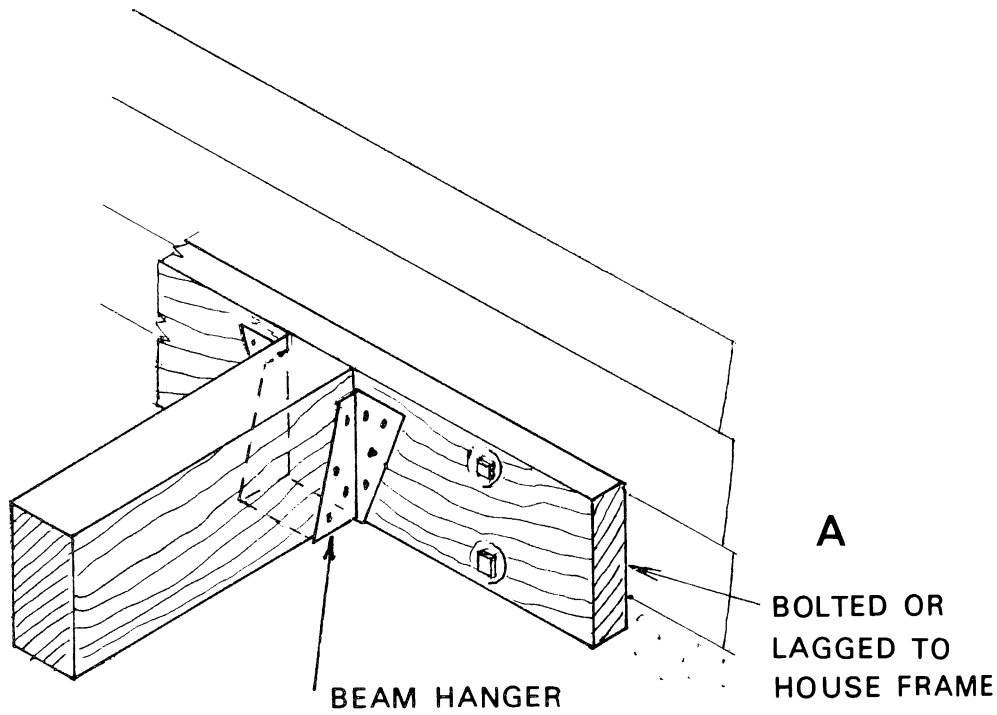

Figure 27. — Beam to house. A — beam hanger; B — ledger support.

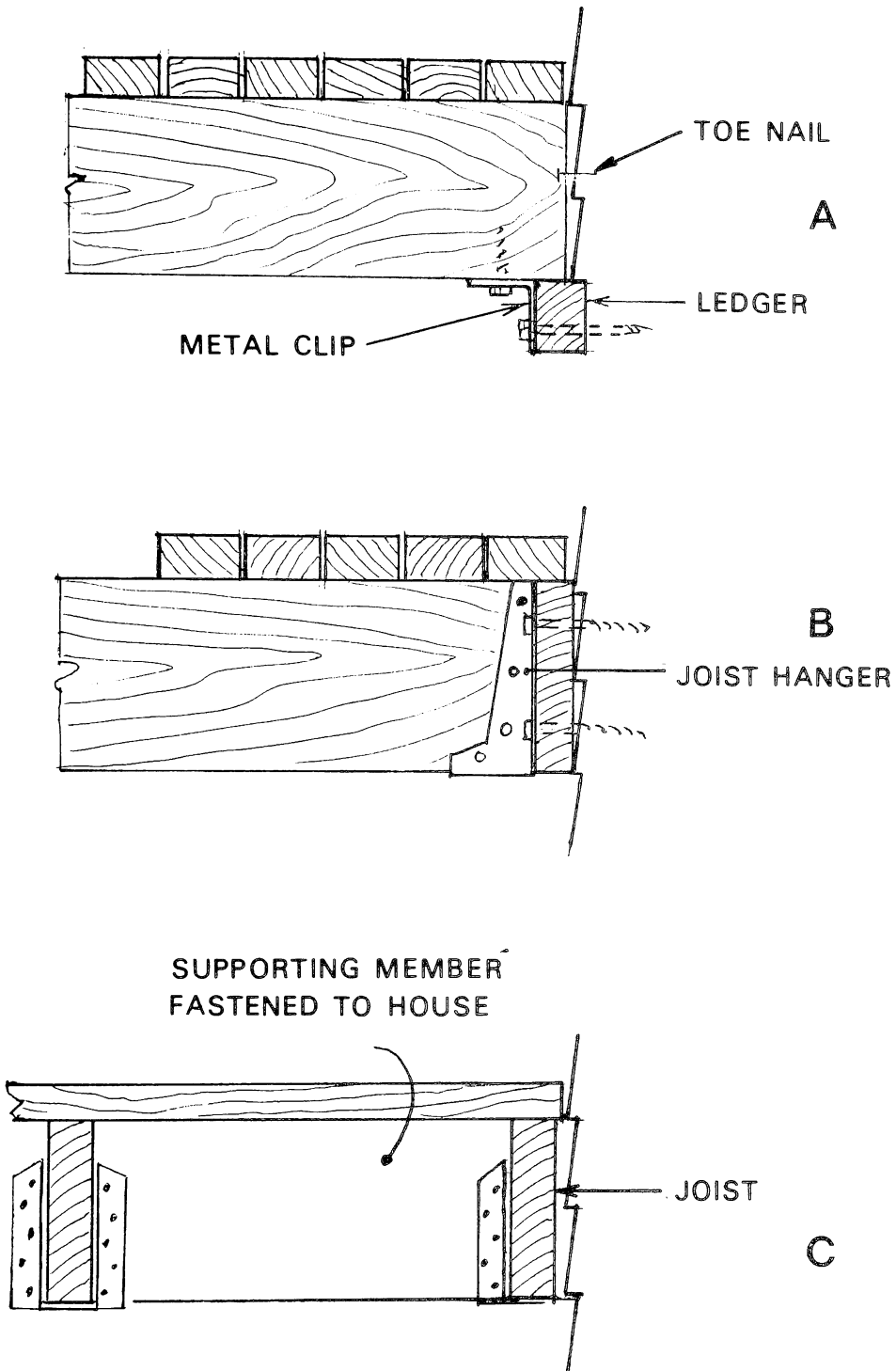

Figure 28. — Joist to house. A — ledger support; B — joist hangers; C — unconnected joists.

and such construction normally requires no additional bracing. However, when posts rest directly on concrete footings or pedestals, and unsupported heights are more than about 5 feet, some system of bracing should be used. Braces between adjacent posts serve the same purpose as bracing in the walls of a house.

Special bracing in the horizontal plane is normally not needed for residential decks of moderate area and height. Decks can be braced efficiently in the horizontal plane by installing galvanized steel strap diagonals just under the deck surface. These should be in pairs in the direction of both diagonals and securely fastened at both ends. An alternative is to use flat 2- by 4-inch or 2- by 6-inch members across one diagonal, securely nailed to the underside of the deck members. In the case of a very large, high deck, it is advisable to consult a design engineer for an adequate bracing procedure.

Types of bracing. — Bracing should be used on each side of a “free” deck to provide racking resistance in each direction. Single bracing (one member per bay) should consist of 2-inch dimension material. When brace length is no greater than 8 feet, 2- by 4-inch members can be used; 2- by 6-inch braces should be used when lengths are over 8 feet. Fastenings should normally consist of lag screws or bolts (with washers) to fasten 2-inch braces to the posts. See section, “Fasteners,” for proper fastener use.

One simple system of single bracing is known as the “W” brace which can be arranged as shown in fig. 29A. Braces are lag-screwed to the post and joined along the centerline. When desired and when space is available, braces can be placed on the inside of the posts.

Another single bracing method between posts is shown in fig. 29B. Braces are located from the base of one post to the top of the adjacent posts. Braces on the adjacent side of the deck should be placed in the opposite direction.

Another system of bracing used between posts is the “X” or cross brace (fig. 29C). When spans and heights of posts are quite great, a cross brace can be used at each bay. However, bracing at alternate bays is normally sufficient. A bolt may be used where the 2-inch braces cross to further stabilize the bay. One-inch

thick lumber bracing is not recommended as it is subject to mechanical damage such as splitting at the nails.

When posts are about 14 feet or more in height, which could occur on very steep slopes, two braces might be required to avoid the use of too long a brace. Such bracing can be arranged as shown in fig. 29D.

Partial bracing. — A plywood gusset brace, or one made of short lengths of nominal 2-inch lumber, can sometimes be used as a partial brace for moderate post heights of 5 to 7 feet. A plywood gusset on each side of a post can also serve as a means of connection between a post and beam (fig. 30A). Use 3/4-inch exterior-type plywood and fasten to the post and beam with two rows of 10^d nails. The top edge of the gusset should be protected by an edge or header member which extends over the plywood.

A partial brace made of 2- by 4-inch lumber can be secured to the beam and posts with lag screws or bolts as shown in fig. 30B. Some member of the deck, such as the deck boards or a parallel edge member, can overlap the upper ends to protect the end grain from moisture. When an overlap member is not available and the area is sufficient for two fasteners, a vertical cut can be used for the brace.

Fastening braces. — Brace-to-post connections should be made to minimize trapped moisture or exposed end grain yet provide good resistance to any racking stresses. The detail in fig. 31A has exposed end grain and should be avoided unless protected by an overlapping header or other member above. Fig. 31B shows a more acceptable cut. No end grain of the brace is exposed. Use two lag screws (or bolts) for 2- by 4-inch and 2- by 6-inch braces.

When two braces join at a post, such as occurs in a “W” brace, connection should be made on the centerline as shown in fig. 32A. A tight joint provides the resistance of all fasteners when one brace is in compression, but there is some hazard in trapped moisture. Fig. 32B shows a spaced joint which is preferred when constant exposure to moisture is a factor.

A flush brace may be used if desired from the standpoint of appearance (fig. 33). This type connection requires that a backing cleat be lagged or bolted to each side of the post. The braces are then fastened to the cleats as shown.

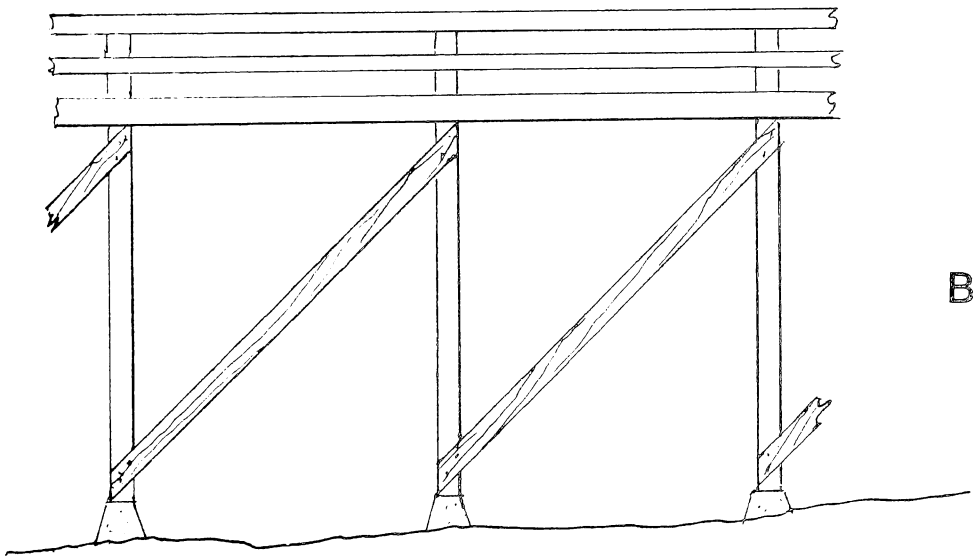
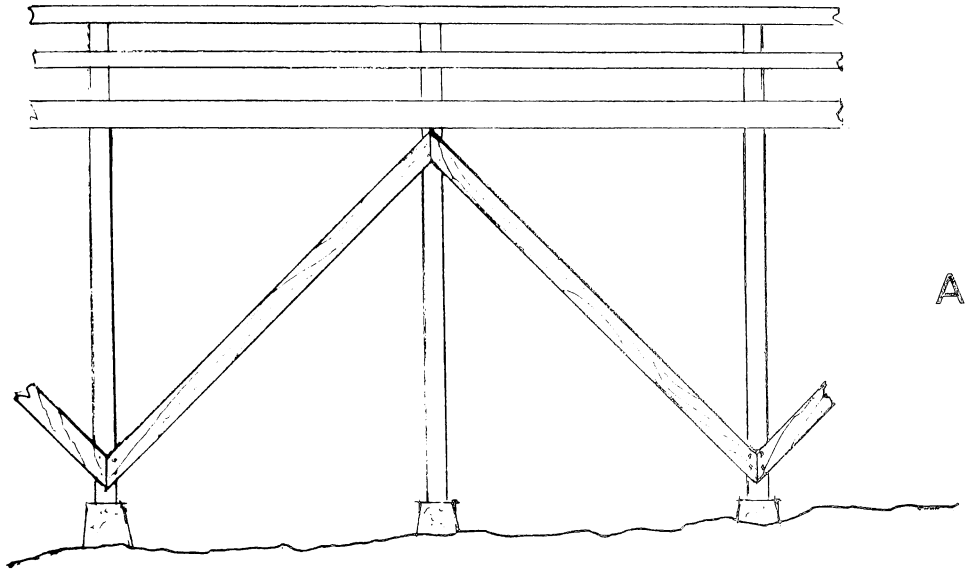

Figure 29. — Bracing. A — “W” brace; B — single direction brace.

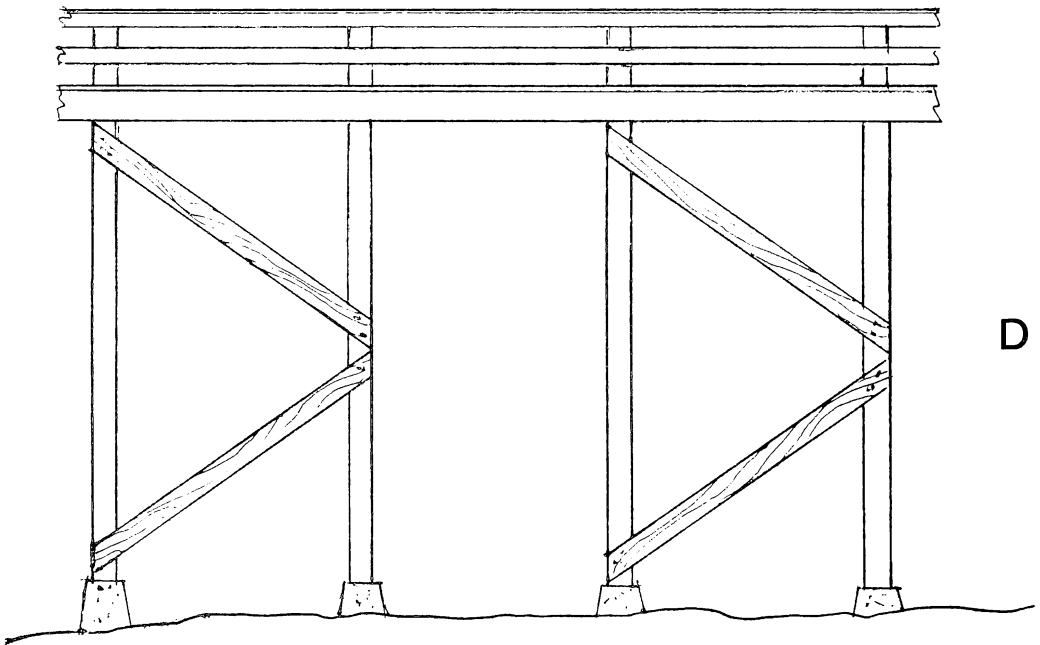
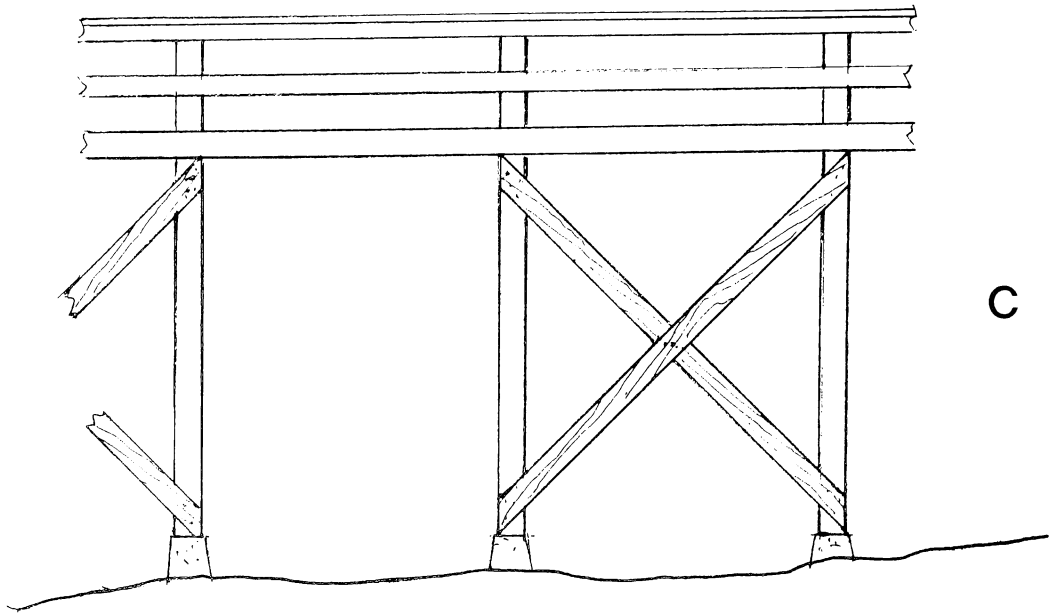

Figure 29. — Bracing (continued). C — cross brace; D — bracing for high posts.

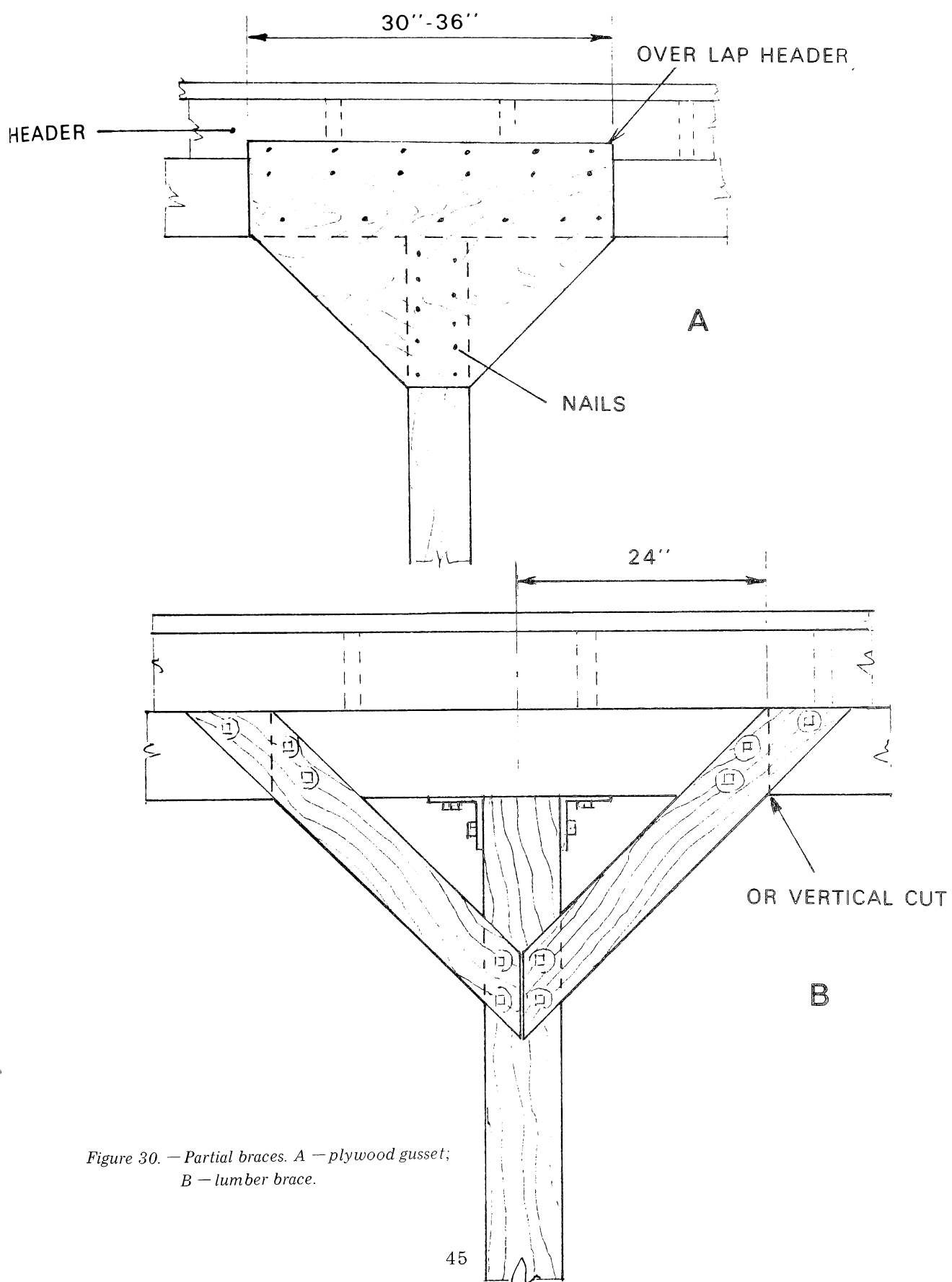

Figure 30. — Partial braces. A — plywood gusset; B — lumber brace.

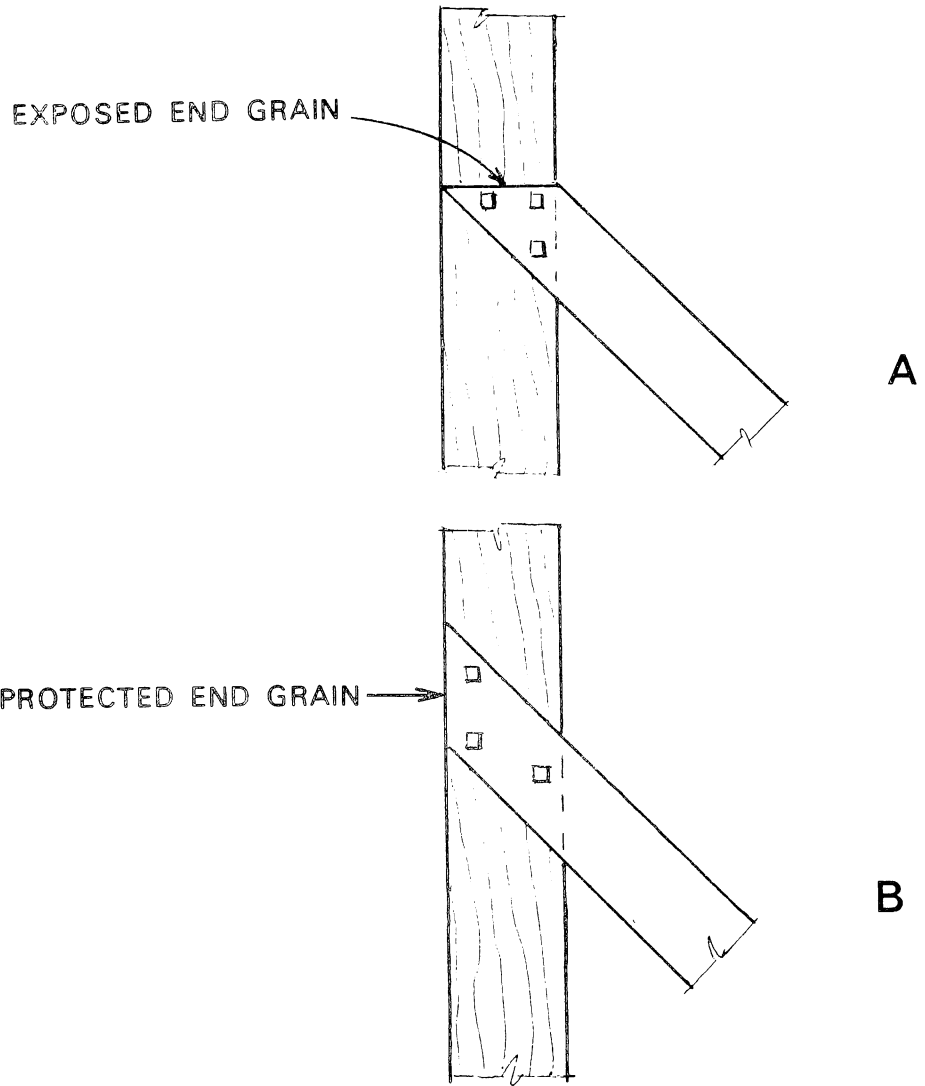

Figure 31. — Brace cuts. A — poor practice; B — better practice.

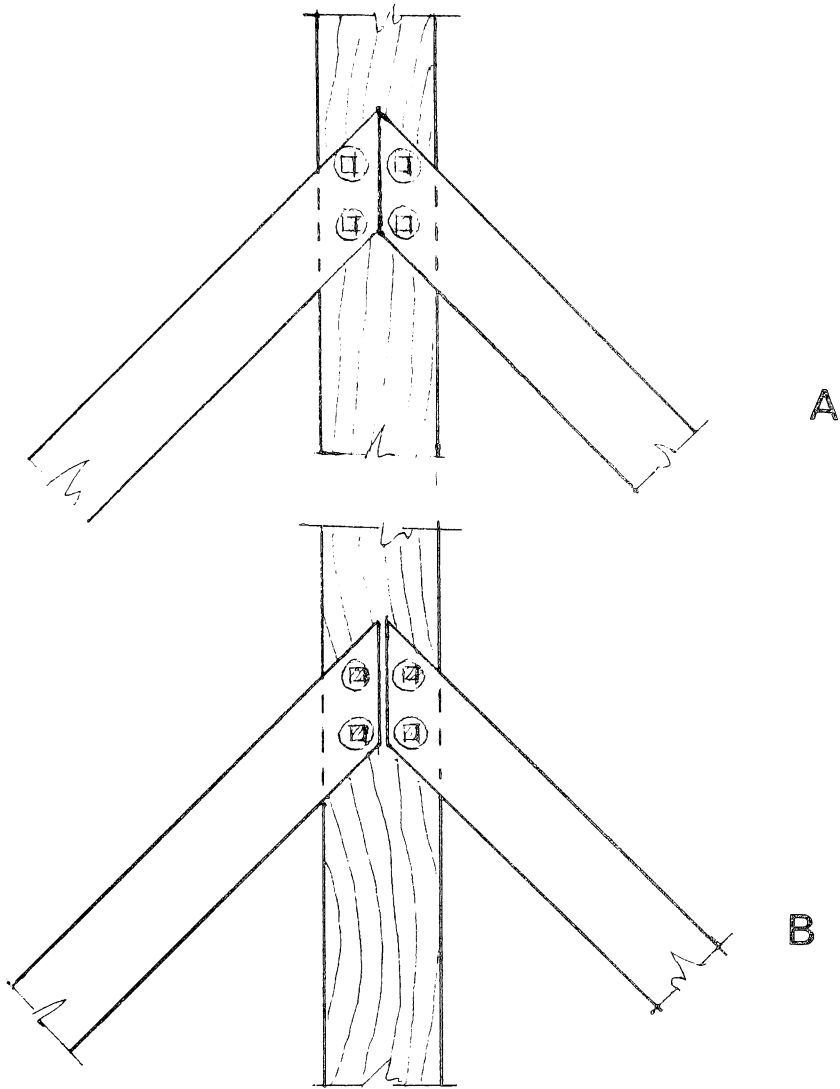

Figure 32. — Joint at post. A — tight joint; B — open joint (preferred).

The use of large, galvanized washers or other means of isolating the brace from the post will provide a smaller area for trapping moisture behind the brace (fig. 34). Such a spacer at each bolt or lag screw might be used when the less decay-resistant wood species are involved.

Joist-to-Beam Connections

When beams are spaced 2 to 5 feet apart and 2- by 4-inch Douglas-fir or similar deck boards

are used, there is no need to use joists to support the decking. The beams thus serve as both fastening and support members for the 2-inch deck boards. However, if the spans between beams are more than 3-1/2 to 5 feet apart, it is necessary to use joists between the beams or 2 by 3 or 2 by 4 on edge for decking (see table 4). To provide rigidity to the structure, the joists must be fastened to the beam in one of several ways.

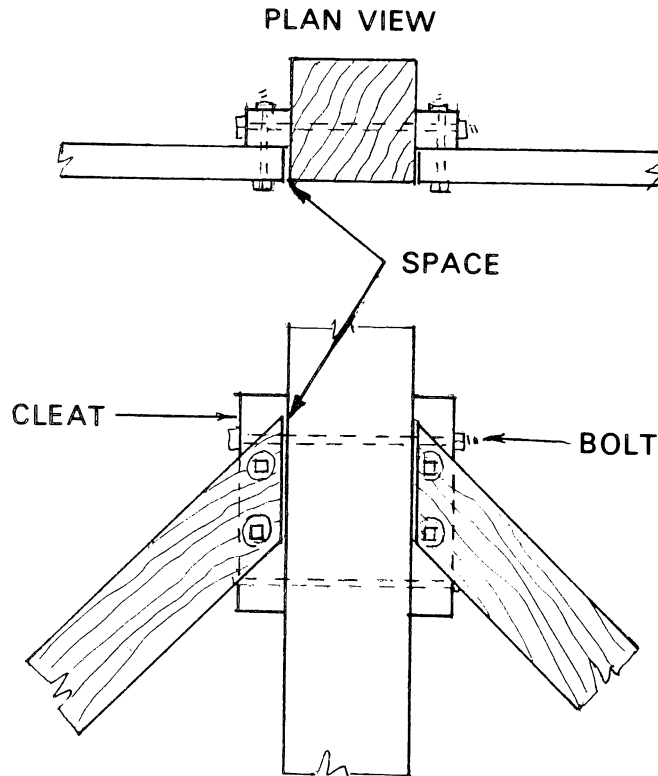

Figure 33. — Flush brace.

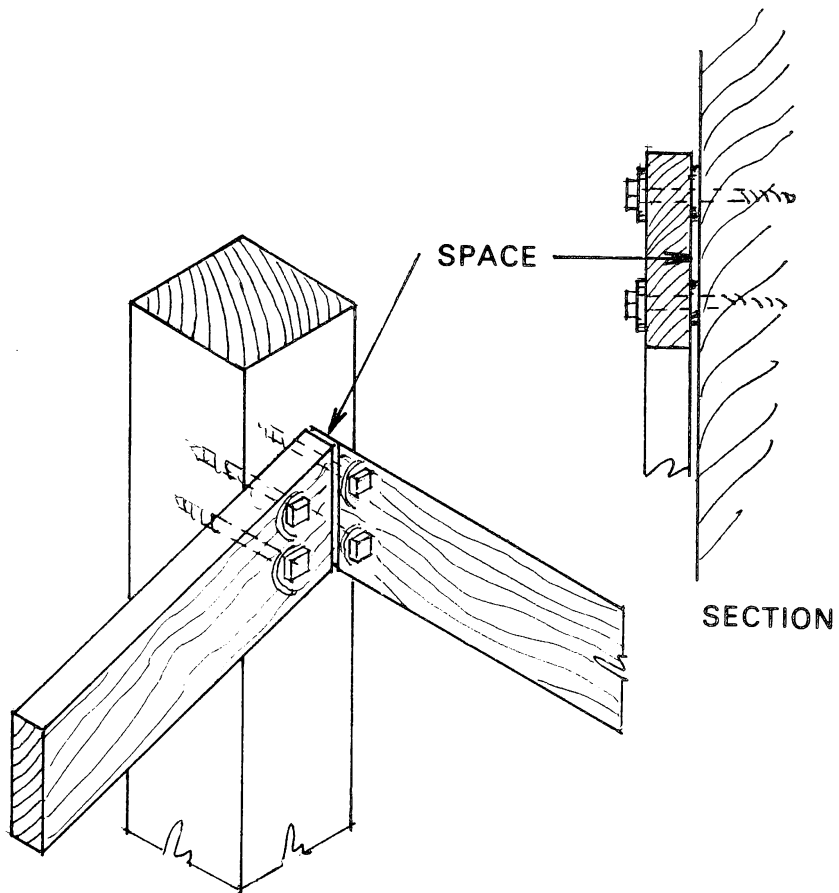

Figure 34. — Spaced brace.

Joists bearing directly on the beams may be toe-nailed to the beam with one or two nails on each side (fig. 35A). Use 10^d nails and avoid splitting. When uplift stresses are inclined to be great in high wind areas, supplementary metal strapping might be used in addition to the toenailing (fig. 35B). Use 24- to 26-ga. galvanized strapping and nail with 1-inch galvanized roofing nails. When a header is used at the joist ends, nail the header into the end of each joist (fig.

35C). Have the header overhang the beam by one-half inch to provide a good drip edge.

Joists located between beams and flush with their tops may be connected in two manners. One utilizes a 2- by 3-inch or 2- by 4-inch ledger which is spiked to the beam. Joists are cut between beams and toe-nailed to the beams at each end (fig. 36A). The joint can be improved by the use of small metal clips.

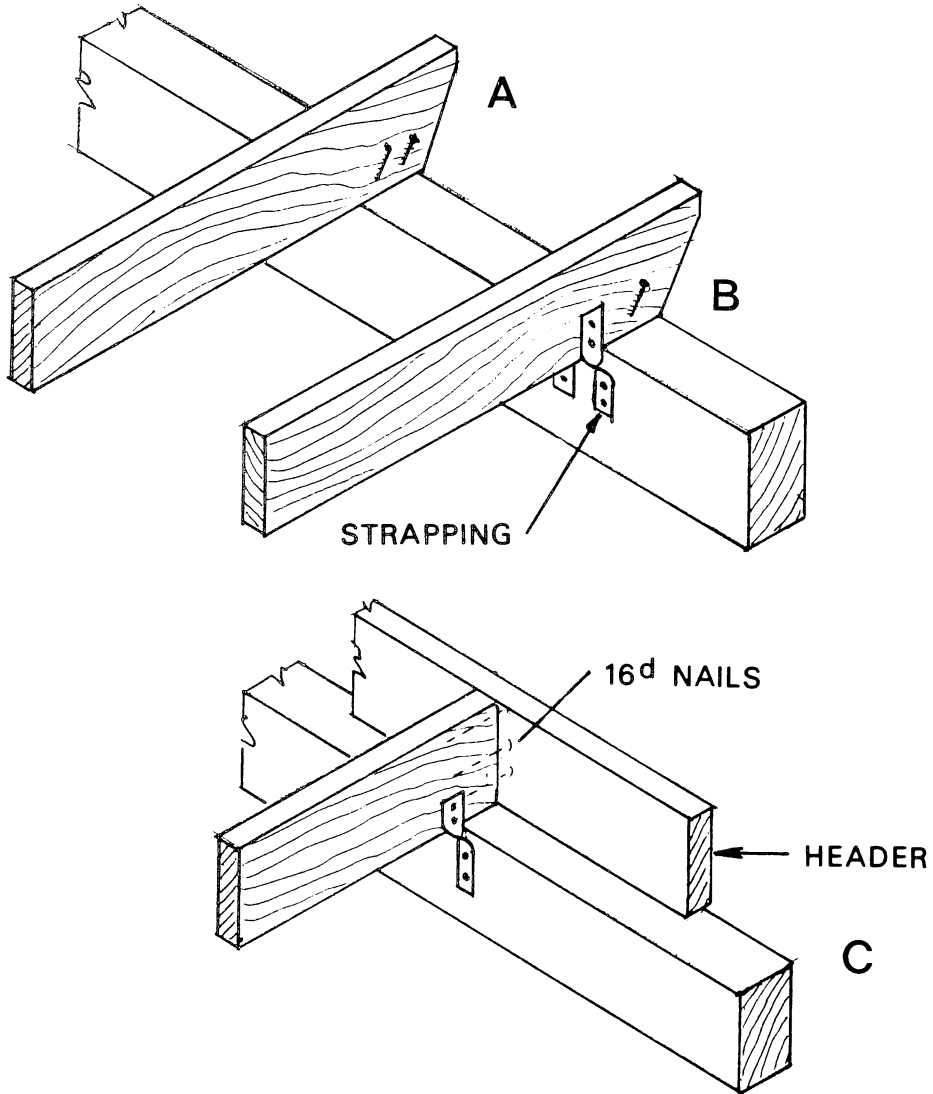

Figure 35. — Joist-to-beam connection. A — toe nail; B — strapping; C — connection with header.

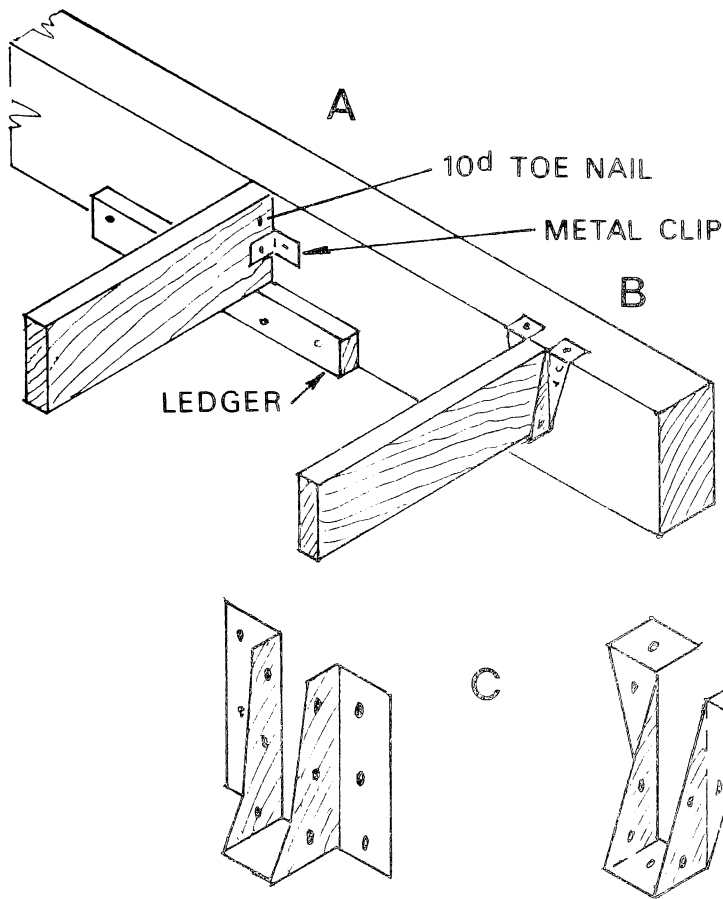

Figure 36. — Joists between beams. A — ledger support; B — joist hanger support; C — joist hangers.

Another method utilizes a metal joist hanger (fig. 36B). The hanger is first nailed to the end of the joist with 1- to 1-1/4-inch galvanized roofing nails and then to the beam. Several types of joist hangers are available (fig. 36C).

Fastening Deck Boards

Deck boards are fastened to floor joists or to beams through their face with nails or screws. Screws are more costly to use than nails from the standpoint of material and labor but have greater resistance to loosening or withdrawal than the nail. A good compromise between the common smooth shank nail and the screw is the deformed shank nail (see "Fasteners"). These

nails retain their withdrawal resistance even under repeated wetting and drying cycles. Both nails and screws should be set flush or just below the surface of the deck board.

Some good rules in fastening deck boards to the joists or beams are as follows:

1. Number of fasteners per deck board — use two fasteners for nominal 2- by 3-inch and 2- by 4-inch decking laid flat (fig. 37A). For 2 by 3's or 2 by 4's on edge, use one fastener per joist (fig. 37B).
2. Size of fasteners — Nails (deformed shank, galvanized, aluminum, etc.):

Nominal 2-inch thick deck boards —
12^d

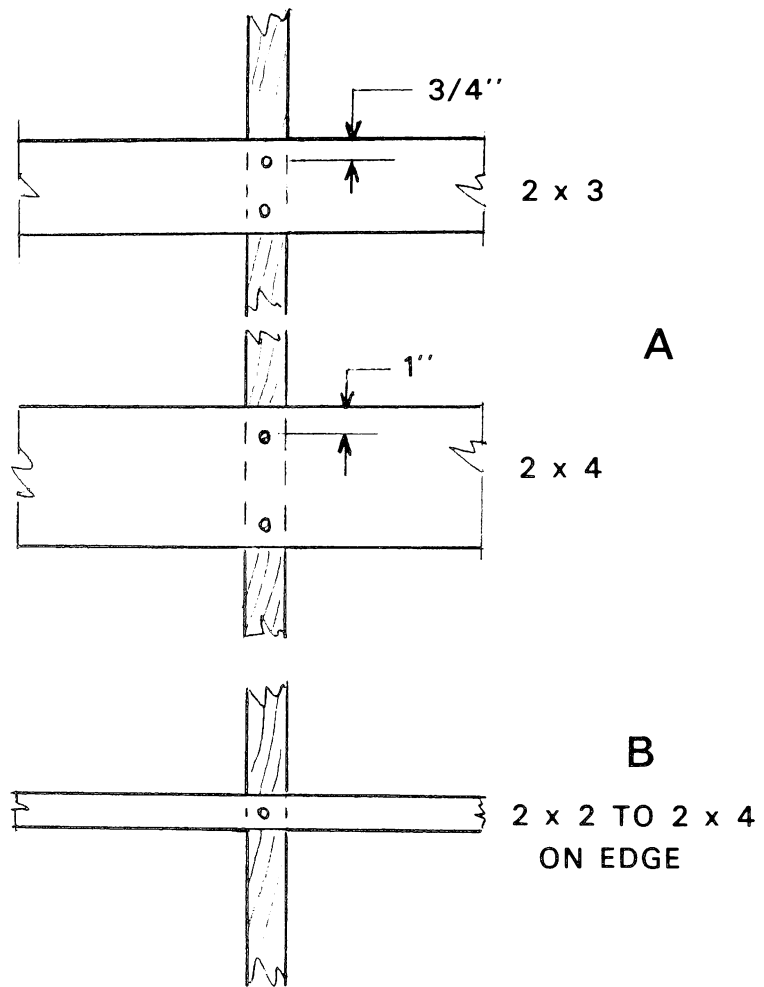

Figure 37. — Fastening deck boards. A — flat deck boards; B — deck boards on edge.

Nominal 2- by 3-inch deck boards
on edge — 5 inch

Nominal 2- by 4-inch deck board
(nailing not recommended)

Screws (flat or oval head, rust proof):

Nominal 2-inch thick deck boards —
3 inch

Nominal 2- by 3-inch deck boards
on edge — 4-1/2 inch

Nominal 2- by 4-inch deck boards
on edge — 5 inch.

3. Spacing — space all deck boards (flat or vertical) one-eighth to one-fourth inch apart (use 8^d or 10^d nail for 1/8-inch spacing).

4. End joints (butt joints) — end joints of flat deck boards should be made over the center of the joist or beam (fig. 38A). In flat grain boards, always place with the bark side up (fig. 38B). When the upper face gets wet, it crowns slightly and water drains off more easily. End joints of any deck boards on edge should be made over a spaced double joist (fig. 39A), a 4-inch or wider single beam, or a nominal 2-inch joist with nailing cleats on each side (fig. 39B).

When deck boards are used on edge, spacers between runs will aid in maintaining uniform spacing and can be made to effect lateral sup-

port between runs by using lateral nailing at the spacers. Spacers as shown in fig. 39C are recommended between supports when spans exceed 4 feet and should be placed so that no distance between supports or spacers exceeds 4 feet. An elastomeric construction adhesive or pentagrease on both faces of each spacer prevents water retention in the joints.

Always dip ends of deck boards in water-repellent preservative before installing.

Always pre-drill ends of 2- by 3-inch or 2- by 4-inch (flat) deck boards of the denser species, or when there is a tendency to split. Pre-drill when screws are used for fastening. Pre-drill all fastening points of 2- by 3-inch or 2- by 4-inch deck boards placed on edge.

To provide longer useful life for decks made of low to moderate decay-resistant species, use one or more of the following precautions:

- (1) Use spaced double joists or beams and place end joints between (fig. 40).
- (2) Lay a strip of building felt saturated with a wood preservative over the beam or joist before installing deck boards.
- (3) Apply an elastomeric glue to the beam or joist edge before installing the deck boards.
- (4) Treat end joints of deck boards made over a support with yearly applications of a water-repellent preservative. (A plunger-type oil can will work well.)

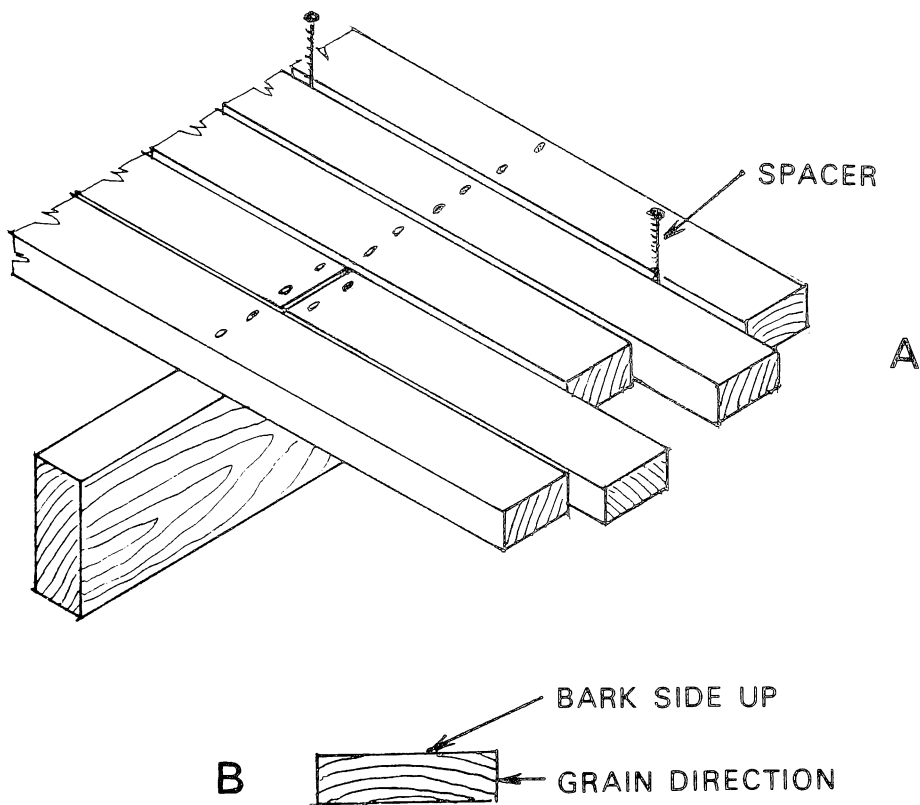

Figure 38. — Fastening flat deck boards. A — spacing between boards; B — grain orientation for flat grain boards.

Fastening Plywood

Plywood panels should generally be installed with a minimum 1/16-inch space between edge and end joints, using the support spacing and nailing schedule indicated in table 6. When caulking is used, a joint space of at least one-fourth inch is usually required.

To avoid unnecessary moisture absorption by the plywood, seal all panel edges with an exterior primer or an aluminum paint formulated for wood. The panel edge sealant can be most conveniently applied prior to installation, while the plywood is still in stacks. Build some slope into the deck area to provide for adequate

drainage. A minimum slope of 1 inch in 8 to 10 feet should be provided when installing the joists or beams.

Provide ventilation for the underside of the deck areas in all cases. For low-level decks, this can be done by leaving the space between the joists open at the ends and by excavating material away from the support joists and beams. For high-level decks over enclosed areas, holes can be drilled in the blocking between joists.

Railing Posts

Low-level decks located just above the grade normally require no railings. However, if the site is sloped, some type of protective railing or

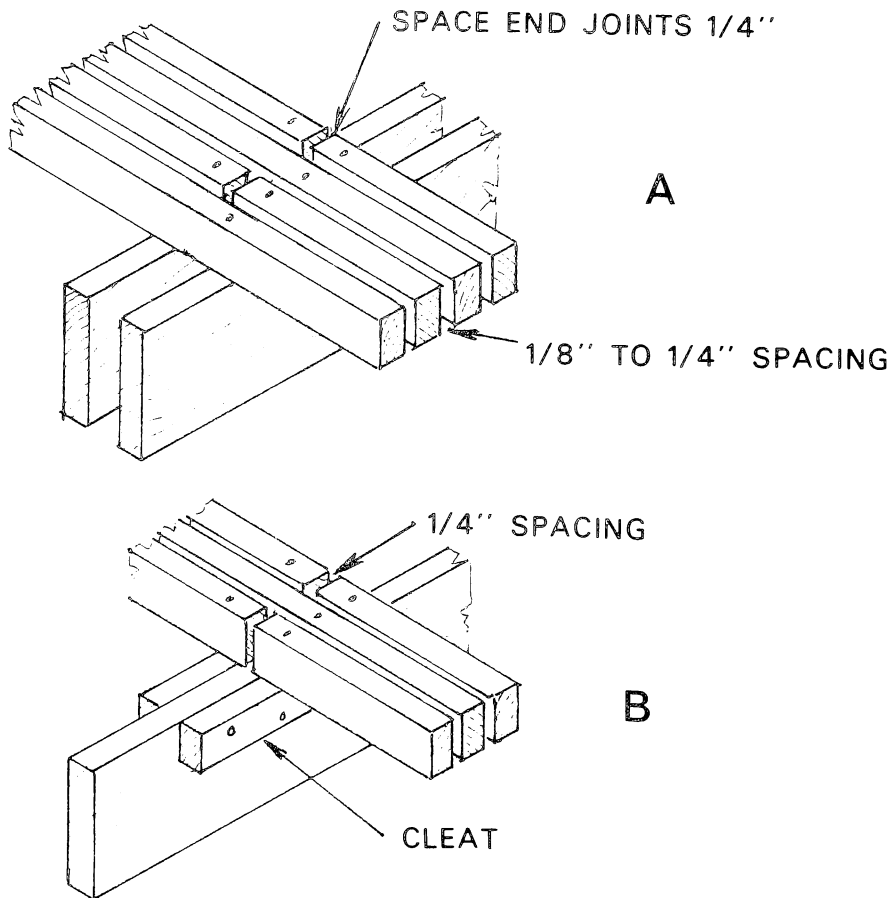
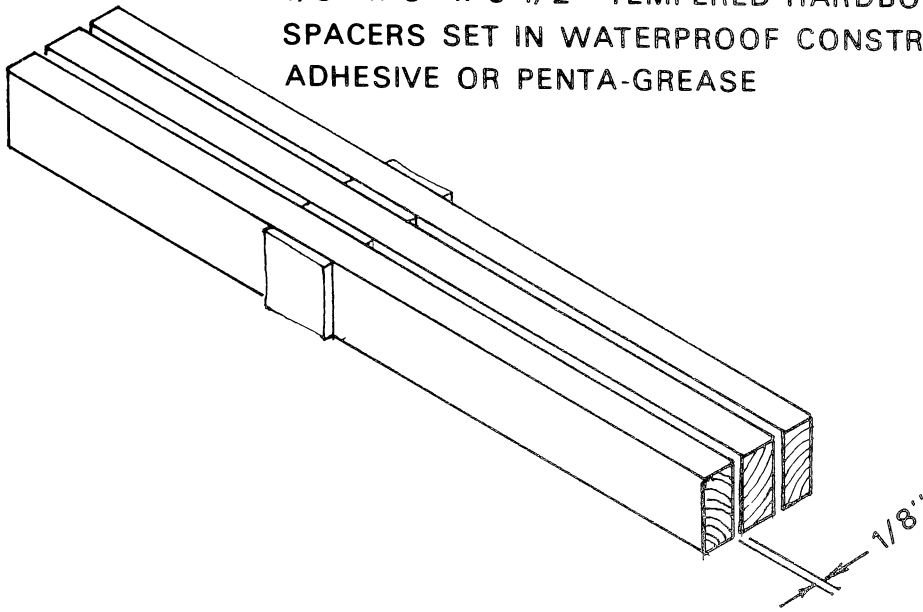

Figure 39. — Fastening "on edge" deck boards. A — installing over double joist or beam; B — installing over single joist or beam; C — spacers for 2x4 decking on edge.

1/8" x 3" x 3-1/2" TEMPERED HARDBOARD
 SPACERS SET IN WATERPROOF CONSTRUCTION
 ADHESIVE OR PENTA-GREASE



C

8d NAILS STAGGERED

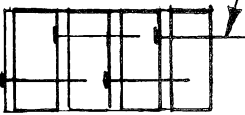

SECTION SHOWING NAILING

system of balusters might be needed, because of the height of the deck.

The key members of a railing are the posts. Posts must be large enough and well fastened to provide strength to the railing. Some type of vertical member such as the post can also serve as a part of a bench or similar edge structure of the deck. Railings should be designed for a lateral load of at least 20 pounds per lineal foot. Thus, posts must be rigid and spaced properly to resist such loads.

One method of providing posts for the deck railing is by the extension of the posts which support the beams (fig. 41). When single or double beams are fastened in this manner, the posts can extend above the deck floor and serve for fastening the railing and other horizontal

members. Railing heights may vary between 30 and 40 inches, or higher when a bench or wind screen is involved. Posts should be spaced no more than 6 feet apart for a 2 by 4 horizontal top rail and 8 feet apart when a 2 by 6 or larger rail is used.

When supporting posts cannot be extended above the deck, a joist or beam may be available to which the posts can be secured. Posts can then be arranged as shown in fig. 42A. Such posts can be made from 2 by 6's for spans less than 4 feet, from 4 by 4's or 2 by 8's for 4- to 6-foot spans, and from 4 by 6's or 3 by 8's for 6- to 8-foot spans. Each post should be bolted to the edge beam with two 3/8-inch or larger bolts determined by the size of the post. This system can also be used when the railing consists of a

number of small baluster-type posts (fig. 42B). When such posts are made of 2- by 2- or 2- by 3-inch members and spaced 12 to 16 inches apart, the top fastener into the beam should be a 1/4- or 3/8-inch bolt or lag screw. The bottom fastener can then be a 12^d or larger deformed shank nail. Pre-drill when necessary to prevent splitting. Wider spacings or larger size posts require two bolts. A 1/8-inch to 1/4-inch space should be allowed between the ends of floor boards and posts.

The ends of beams or joists along the edge of the deck can also be used to fasten the railing posts. One such fastening system is shown in fig. 43. Single or double (one on each side) posts are bolted to the ends of the joists or beams. Space the bolts as far apart as practical for better lateral resistance.

The practice of mounting posts on a deck board should be avoided. Not only is the railing structurally weak, but the bottom of the post has end grain contact with a flat surface. This could induce high moisture content and possible decay.

Deck Benches

High-deck benches. — At times there is an advantage in using a bench along the edge of a high deck, combining utility with protection. One such design is shown in fig. 44. The vertical back supporting members (bench posts), spaced no more than 6 feet apart, are bolted to the beams. They can also be fastened to extensions of the floor joists. When beams are more than 6 feet apart, the bench post can be fastened to an edge joist in much the same manner as railing posts. The backs and seat supports should be spaced no more than 6 feet apart when nominal 2-inch plank seats are used.

Low-deck benches. — Benches can also be used along the edge of low decks. These can be simple plank seats which serve as a back drop for the deck. Such bench seats require vertical members fastened to the joists or beams with cross cleats (fig. 45). For nominal 2-inch plank seats, vertical supports should be bolted to a joist or beam and be spaced no more than 6 feet apart. A single wide support (2 by 10) (fig.

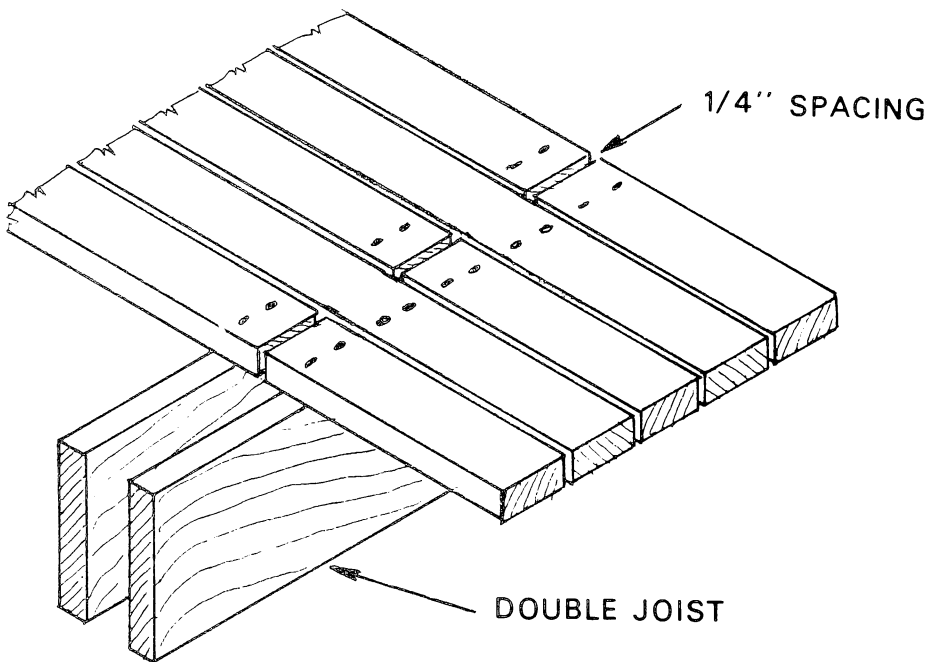

Figure 40. — End joints of decking over double joist.

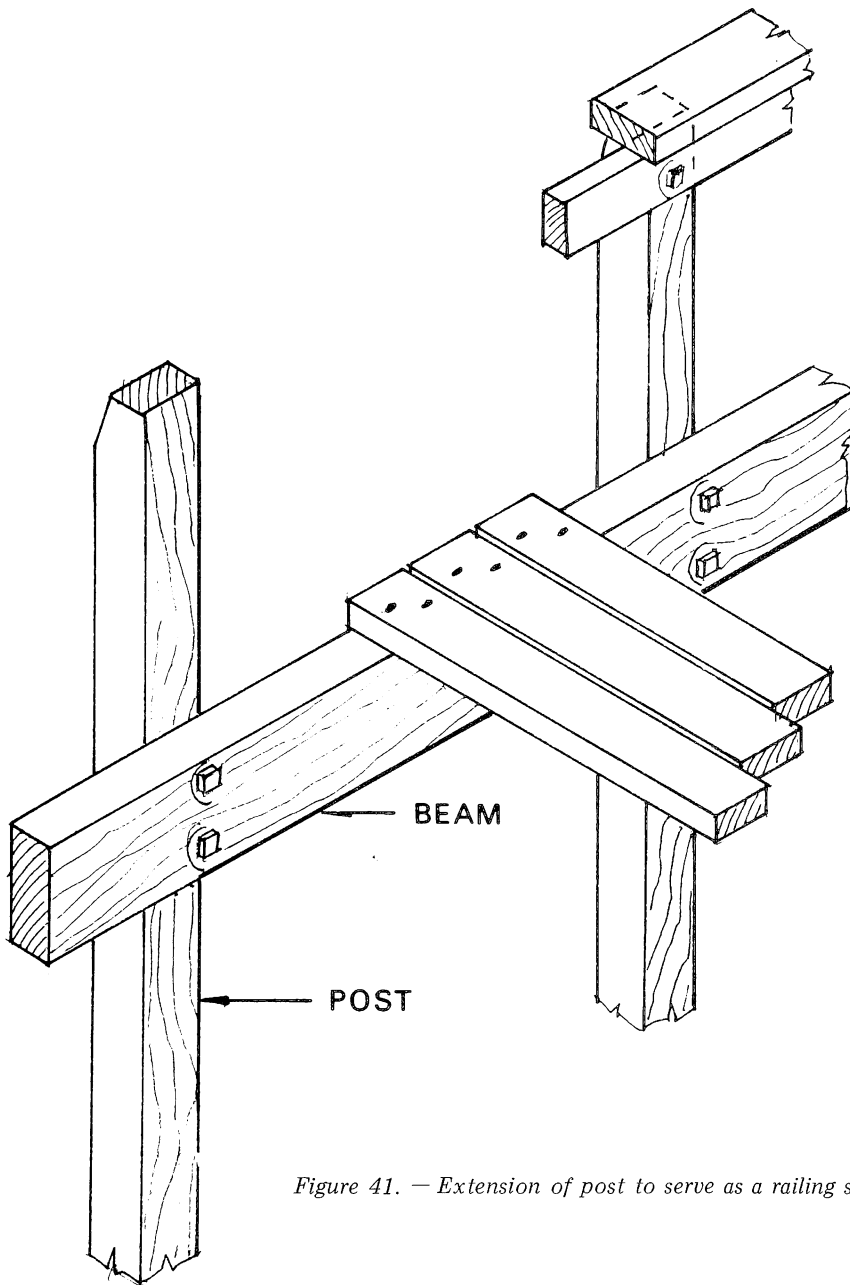

Figure 41. — Extension of post to serve as a railing support.

45A) or double (two 2 by 4's) supports (fig. 45B) can be used. Cleats should be at least 2 by 3 inches in size.

Such member arrangements can also be used as a step between two decks with elevation differences of 12 to 16 inches. Many other bench arrangements are possible; but spans, fastenings, and elimination of end grain exposure should always be considered.

Railings

Horizontal railings. — The top horizontal members of a railing should be arranged to protect the end grain of vertical members such as posts or balusters. A poorly designed railing detail is shown in fig. 46. Such details should be avoided, as the end grain of the baluster-type posts is exposed. Fig. 47 is an improvement,

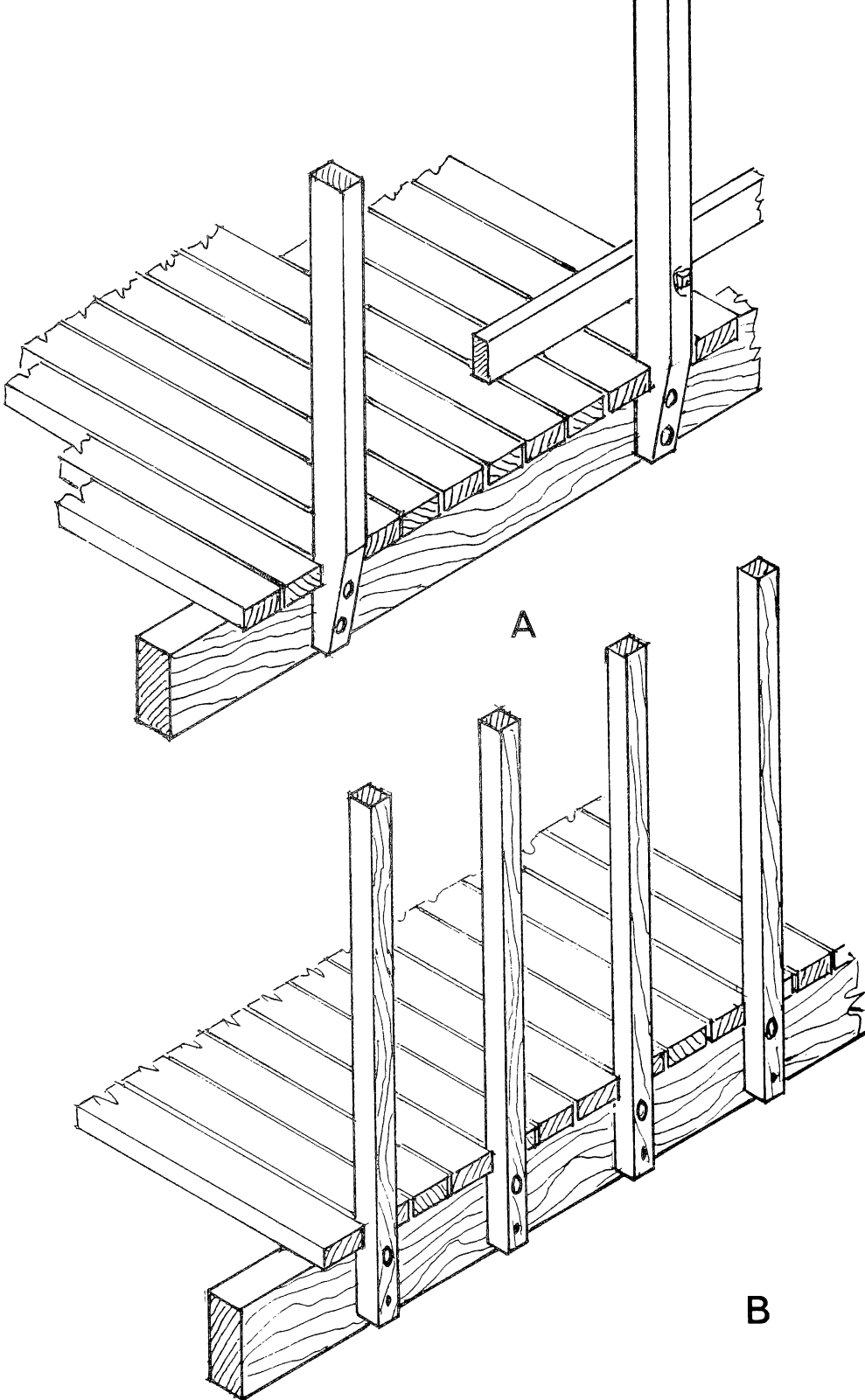

Figure 42. — Railing posts fastened to edge of deck member. A — spaced posts (4 feet and over); B — baluster-type posts.

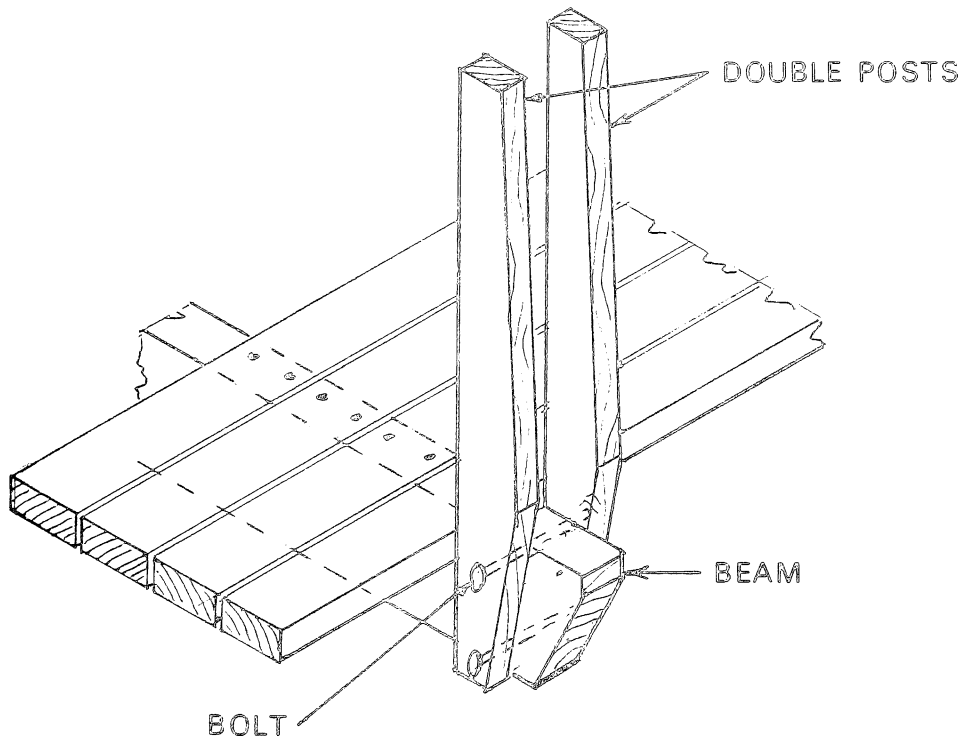

Figure 43. — Double railing posts at beam or joist ends.

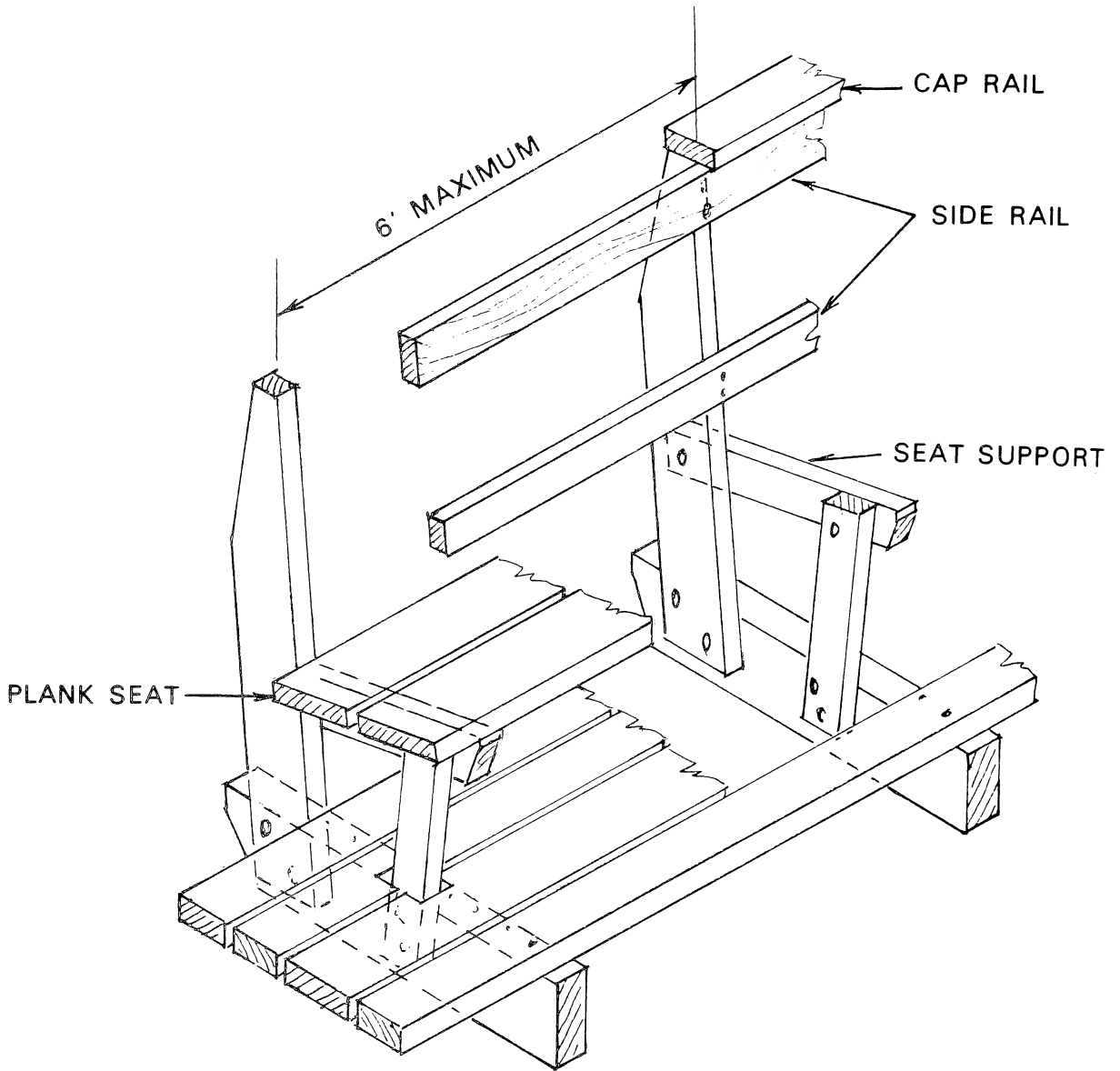

Figure 44. — Deck bench.

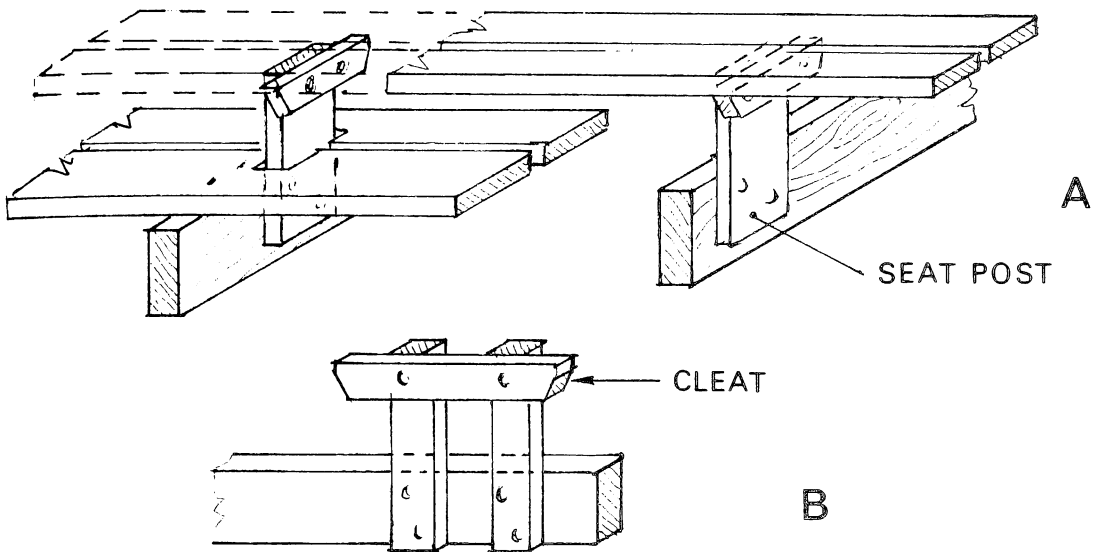

Figure 45. — Bench seats. A — single support and cross cleat; B — double support.

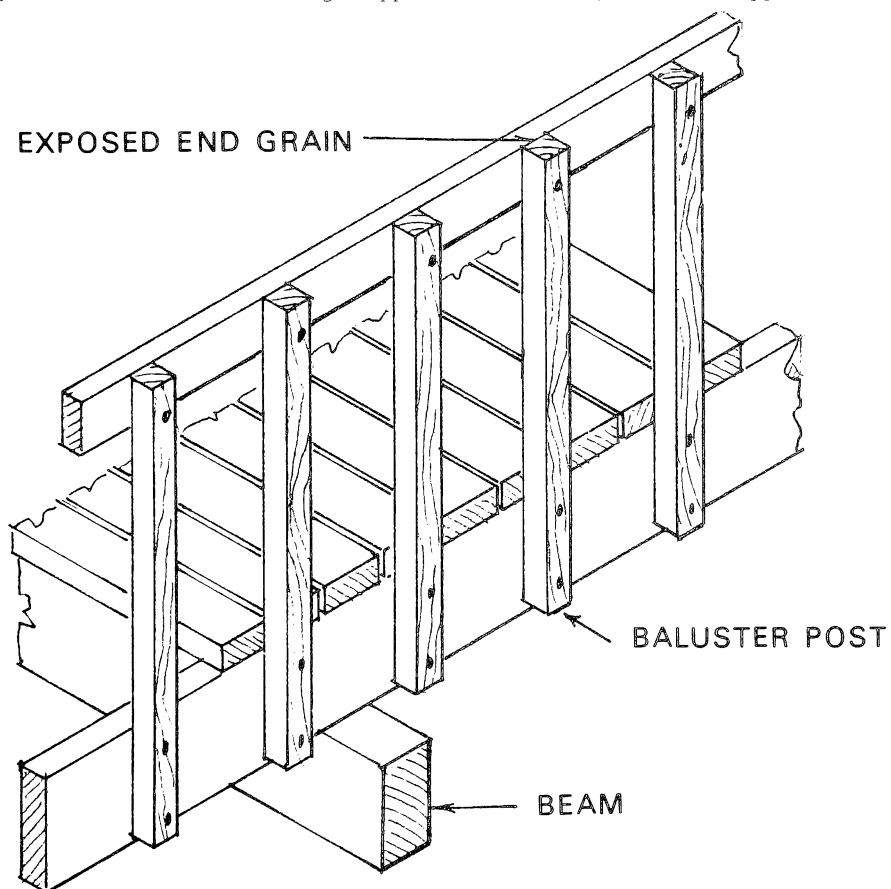

Figure 46. — Poorly designed railing detail.

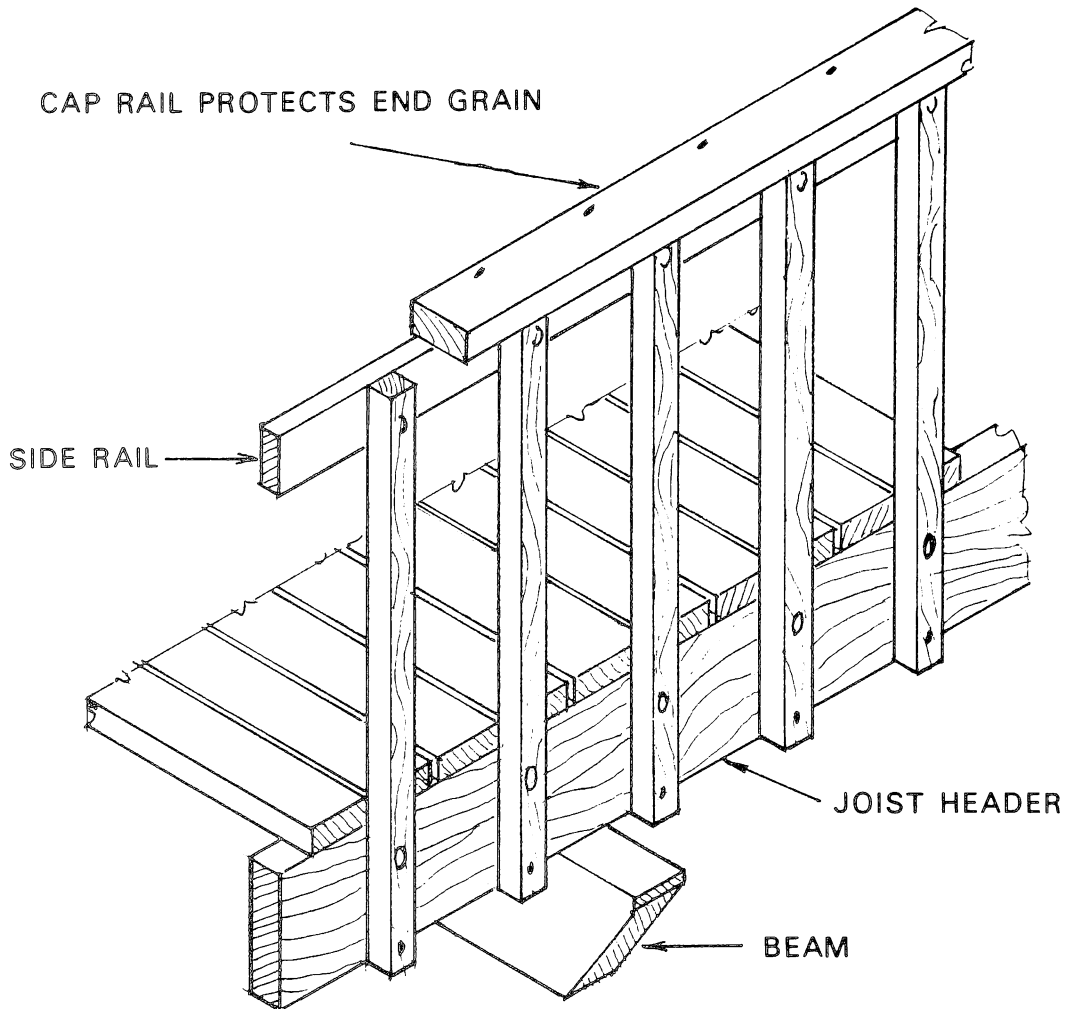

Figure 47. — Good railing detail.

as the end grain of the balusters is protected by the cap rail.

The upper side rail, which is usually a 2- by 4-inch or wider member, should be fastened to the posts with a lag screw or bolt at each crossing. The cap rail then can be nailed to the edge of the top rail with 12^d deformed shank nails spaced 12 to 16 inches apart.

When railing posts are spaced more than about 2 feet apart, additional horizontal members may be required as a protective barrier (fig. 48). These side rails should be nominal 2- by 4-inch members when posts are spaced no more

than 4 feet apart. Use 2 by 6's when posts are spaced over 4 feet apart.

Rail fastenings. — When the upper side rail is bolted to the post (fig. 48), the remaining rails can be nailed to the posts. Use two 12^d deformed shank nails at each post and splice side rails and all horizontal members at the centerline of a post. Posts must be more than 2 inches in thickness to provide an adequate fastening area at each side of the center splice.

A superior rail termination consists of the use of a double post (fig. 49). Horizontal members are spaced about 1 inch apart, which al-

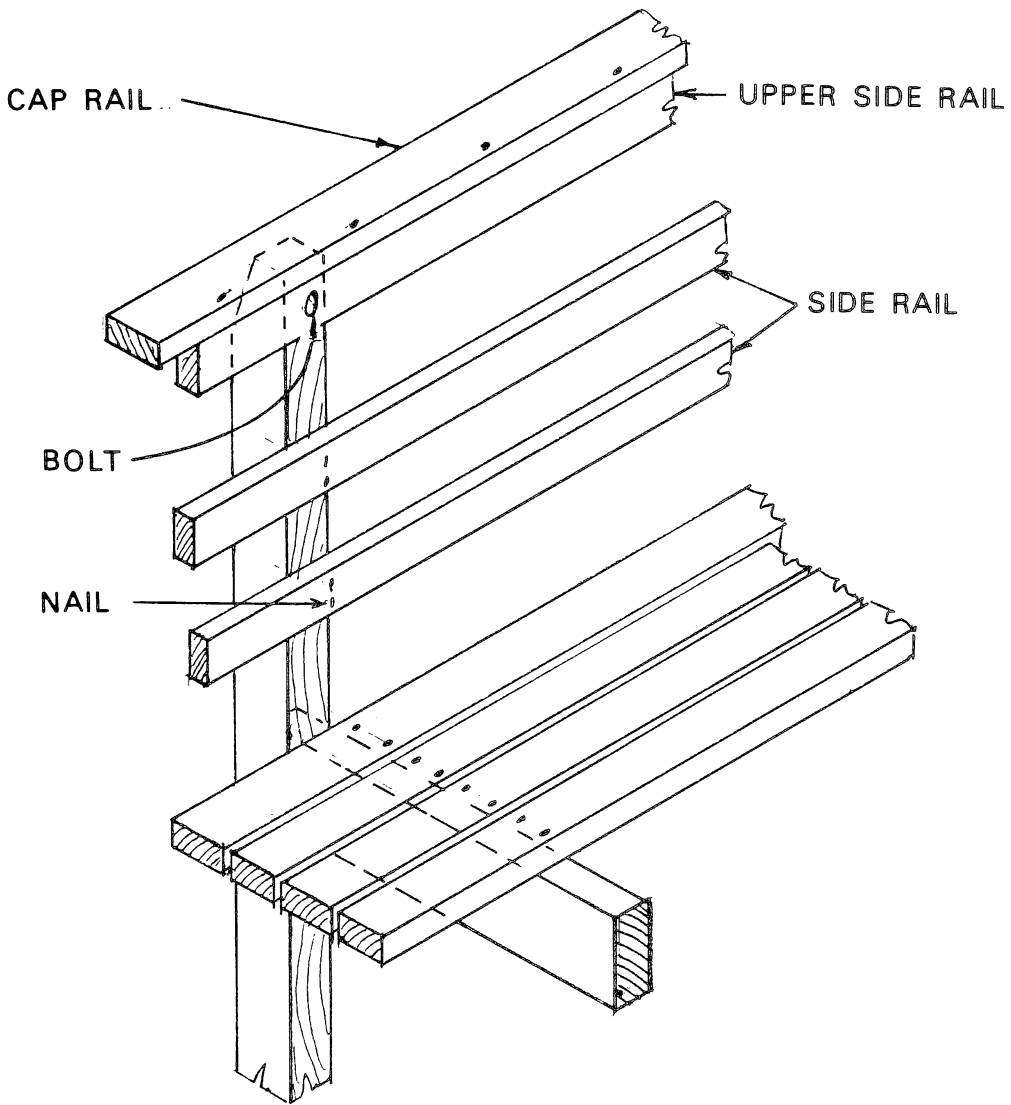

Figure 48. — Side rails for deck railing.

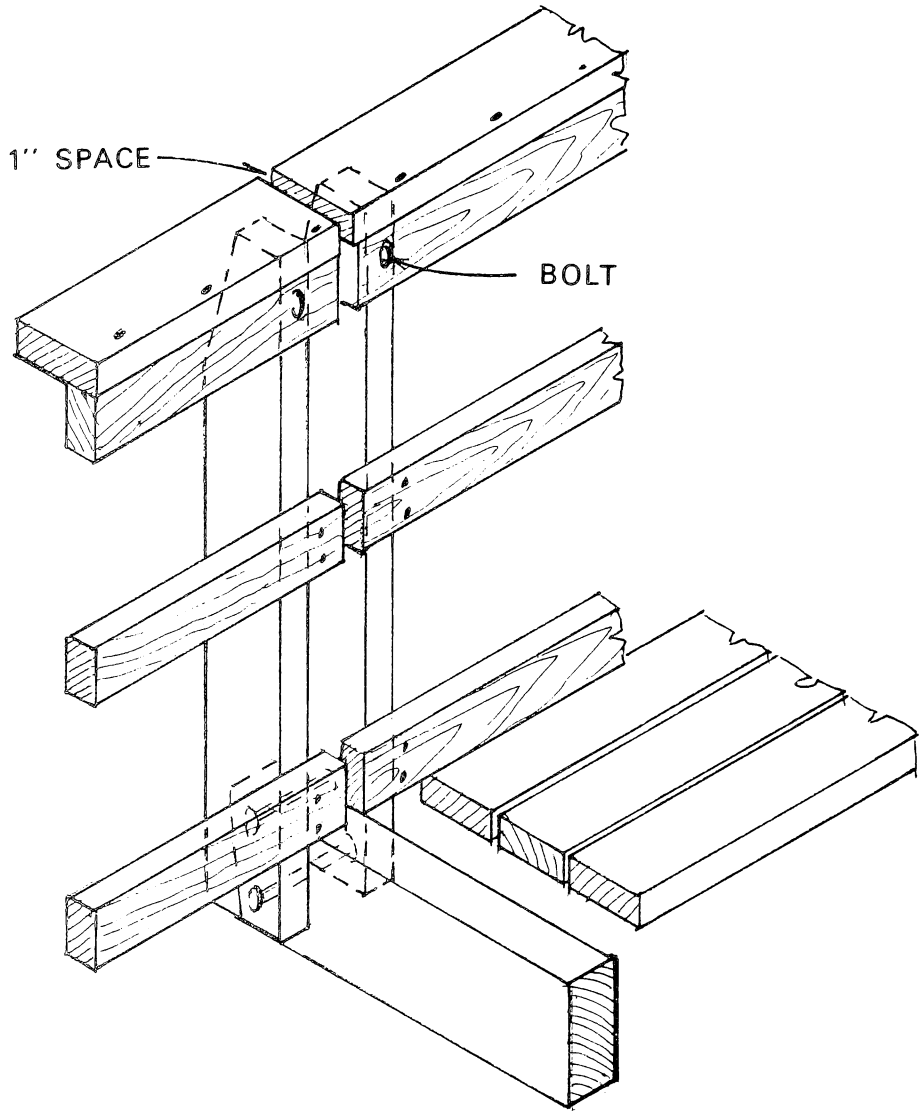

Figure 49. — Spaced rail joints — good practice.

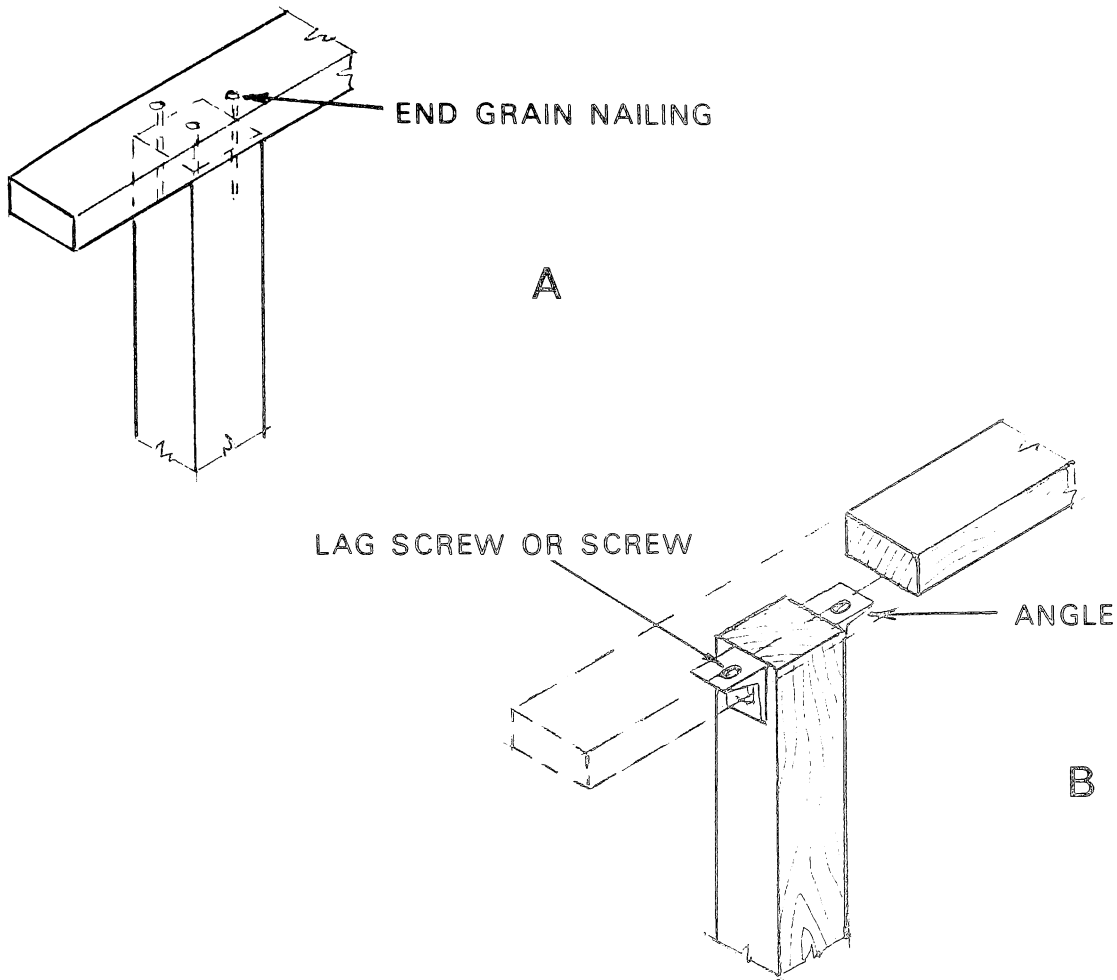

Figure 50. — Fastening cap rail to post. A — nailed (end grain), a poor practice; B — angle iron connection, a good practice.

lows ends of members to dry quickly after rains. As in all wood deck members, the ends should always be dipped in water-repellent preservative before assembly.

Cap rail connections. — A good method of fastening cap rail to the post has been shown in the previous section and in fig. 47. In some designs, however, the cap rail without additional members may be specified. An unsatisfactory method of connecting a cap rail to the post is by nailing (fig. 50A). End grain nailing is not recommended in such connections. A better method is shown in fig. 50B. Short lengths of galvanized angle irons are fastened to the post with lag screws or bolts. The cap rail is then fastened with short (1-1/2 - inch) lag

screws. Although this is certainly not as simple as nailing, it provides an excellent joint and fastenings are not exposed to the weather.

Miscellaneous rail connections. — There may be occasions in the construction of a railing of a deck to use members between the posts rather than lapping the posts. This might be in construction of an adjoining wind screen or mid-height railings between posts. Such connections might also be adaptable to fences where horizontal members are located between posts. The connection to the post is the important one, as it must be rigid as well as minimize areas where moisture could be trapped. Dado cuts for a 2-inch rail are shown in figs. 51A and 51B. Although these are reasonably good struc-

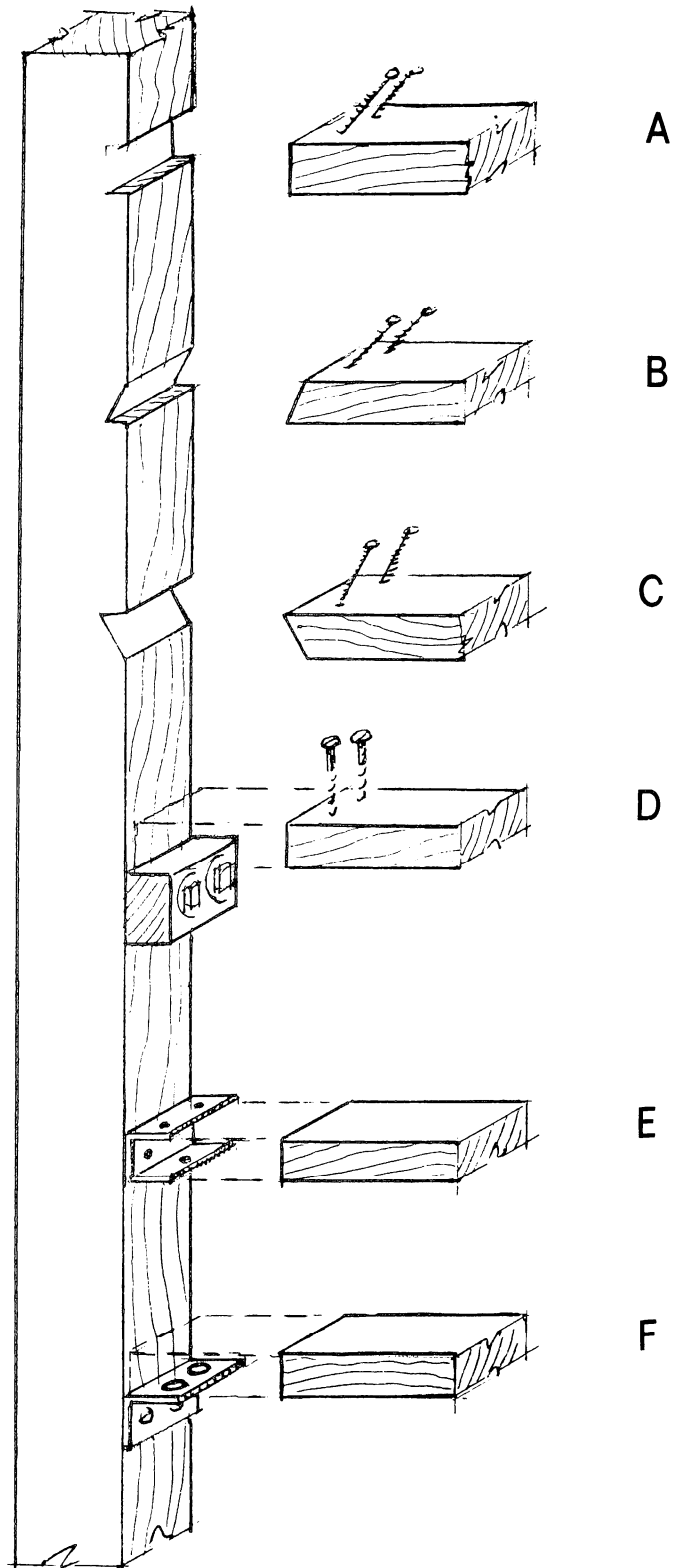

Figure 51. — Rail-to-post connections.
 A-C — dado cuts (not recommended);
 D — wood block support;
 E — metal connector;
 F — angle iron.

turally, moisture could be retained at the end grain of the bottom cut. Fig. 51C shows the notch reversed. This will not retain moisture as much as the previous cuts, but the member must be cut precisely to provide a rigid joint. A wood block lag screwed to the side of the post serves as a good fastening area for the rail (fig. 51D). This is a good connection when the rail is spaced slightly away from the post. The rail should be fastened to the block with screws.

A commercial-type bracket is shown in fig. 51E. This connector can also be used to advantage for 1-inch members used in a fence or a wind screen. Another good method utilizes a small angle iron lagged to the post (fig. 51F). The rail is then fastened to the angle with lag screws from below.

Stairways

There is often a need for a stairway as an access to a deck or for use between decks with different levels. Exterior stairs are much the same as stairs within a house, except that details which avoid trapped moisture or exposed end grain of the members should be used.

Research has indicated that for woods with moderate to low decay resistance, a three-minute dip in a water repellent preservative for all members at least tripled the average service life of exterior stairways and their parts (12). Use of all-heartwood of decay-resistant species or of pressure-treated wood will insure even longer life.

Stair stringers. — A basic stair consists of stair stringer (sometimes called stair carriage) and treads. Additional parts include balusters and side cap rails and, on occasion, risers. The supporting members of a stair are the stringers. Stringers are used in pairs spaced no more than 3 feet apart. They are usually made of 2- by 10-inch or 2- by 12-inch members. Stringers must be well secured to the framing of the deck. They are normally supported by a ledger or by the extension of a joist or beam. A 2- by 3-inch or 2- by 4-inch ledger nailed to the bottom of an edge framing member with 12^d nails supports the notched stringer (fig. 52A). Toenailing or small metal clips are used to secure the carriage in place. Stair stringers can also be bolted to the ends of joists or beams when they are spaced no more than about 3 feet apart (fig.

52B). Use at least two 1/2-inch galvanized bolts to fasten the stringer to the beam or joist.

The bottom of the stair stringers should be anchored to a solid base and be isolated from any moisture source. Two systems frequently used consist of metal angles anchored to a concrete base (figs. 53A and 53B). The angles should be thick enough to raise the stringer off the concrete, which should also be sloped for drainage. They might also be fastened to a treated wood member anchored in the concrete or in the ground.

Tread and riser size. — The relation of the tread width ("run") to the riser height is important in determining the number of steps required. For ease of ascent, the rise of each step in inches times the width of the tread in inches should equal 72 to 75 (fig. 54A). Thus, if the riser is 8 inches (considered maximum for stairs), the tread would be 9 inches. Or if the riser is 7-1/2 inches, the tread should be about 10 inches. Thus, the number of risers and treads can be found when the total height of the stair is known. Divide total rise in inches by 7-1/2 (each riser) and select the nearest whole number. Thus, if the total rise is 100 inches, the number of risers would be 13 and the total run, about 120 inches (fig. 54B).

Tread support. — Stair treads can be supported by dadoes cut into the stringer (fig. 55A). Stringers can also be notched to form supports for the tread and riser (fig. 55B). However, both methods introduce end grain exposure and possible trapped moisture and should be avoided for exposed stairs, especially when untreated, low decay-resistant species are used.

A better method of tread support consists of 2- by 4-inch ledgers or cleats bolted to the stair stringers and extended to form supports for the plank treads (fig. 56A). The ledgers can be sloped back slightly so that rain will drain off the treads. Ledgers might also be beveled slightly to minimize tread contact. Nail 2- by 10-inch or 2- by 12-inch treads to the ledgers with three 12^d deformed shank nails at each stringer. Rust-proof wood screws 3 inches in length can also be used. Always place plank treads with bark side up to prevent cupping and retention of rain water. Treads can also be made of two 2- by 6-inch planks, but the span must be limited to 42 inches for the less-dense woods (fig. 56B).

Another method of fastening the stair cleats

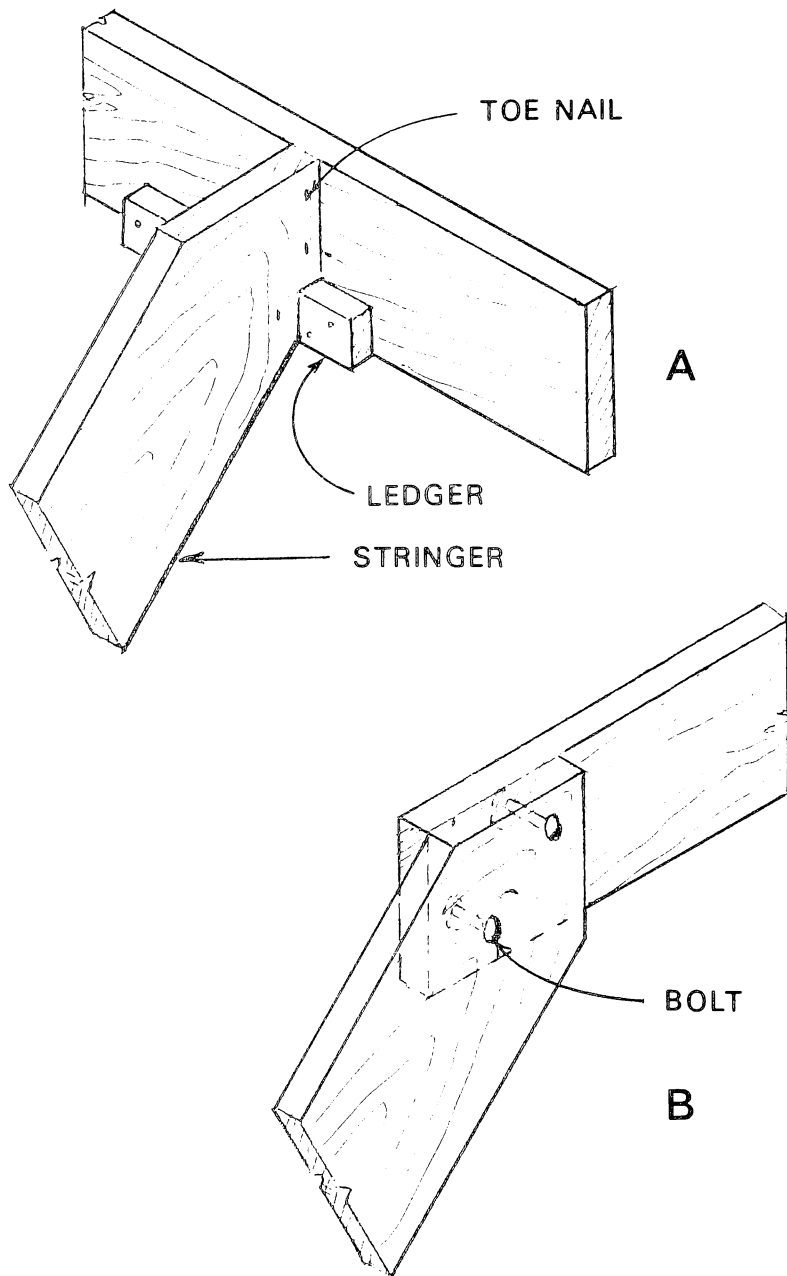

Figure 52. — Stair stringer supports. A — ledger; B — bolt.

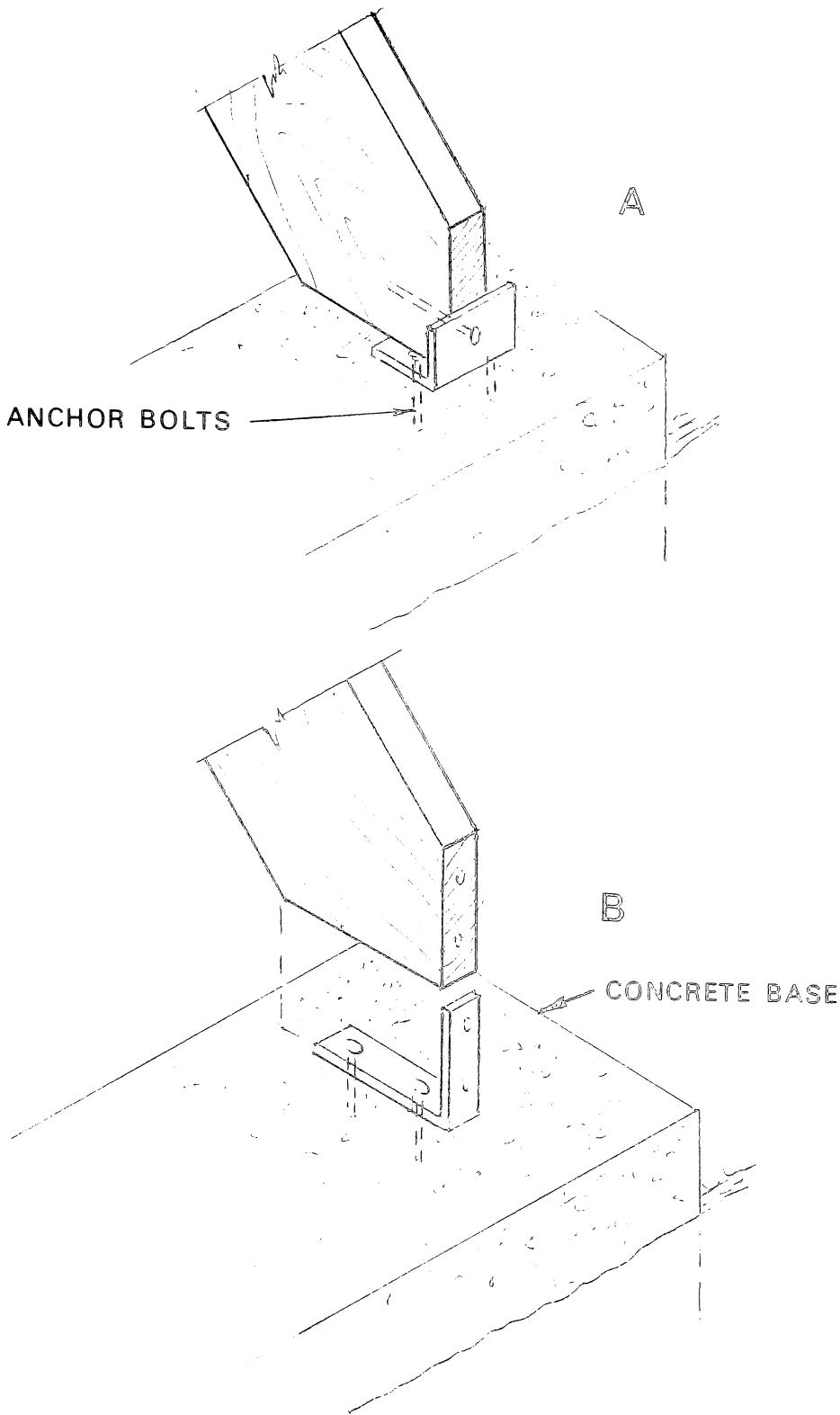

Figure 53. — Fastening the bottom of stair stringer. A and B — angle iron anchors.

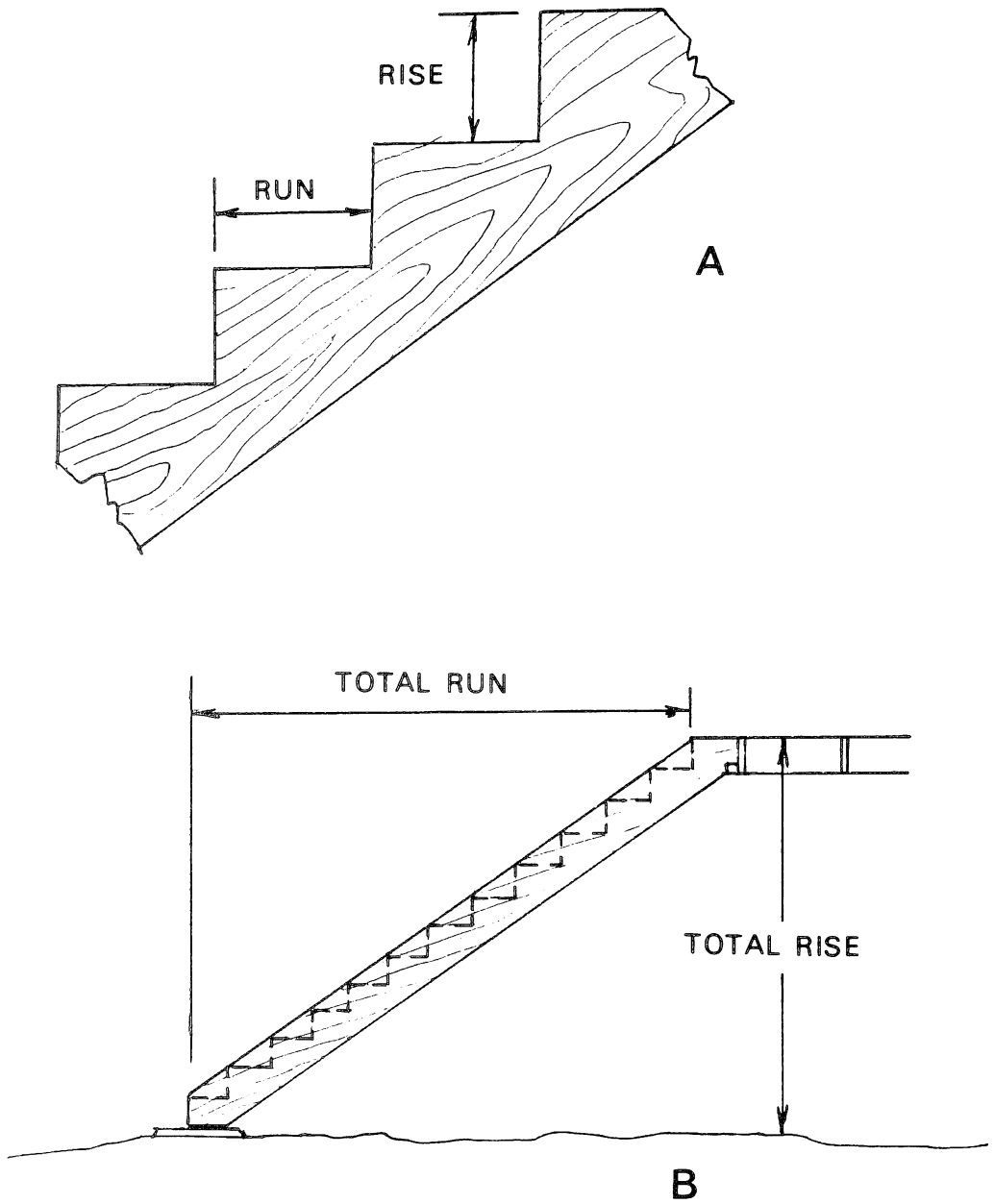

Figure 54. — Riser-to-tread relationship. A — individual step. B — total rise and run.

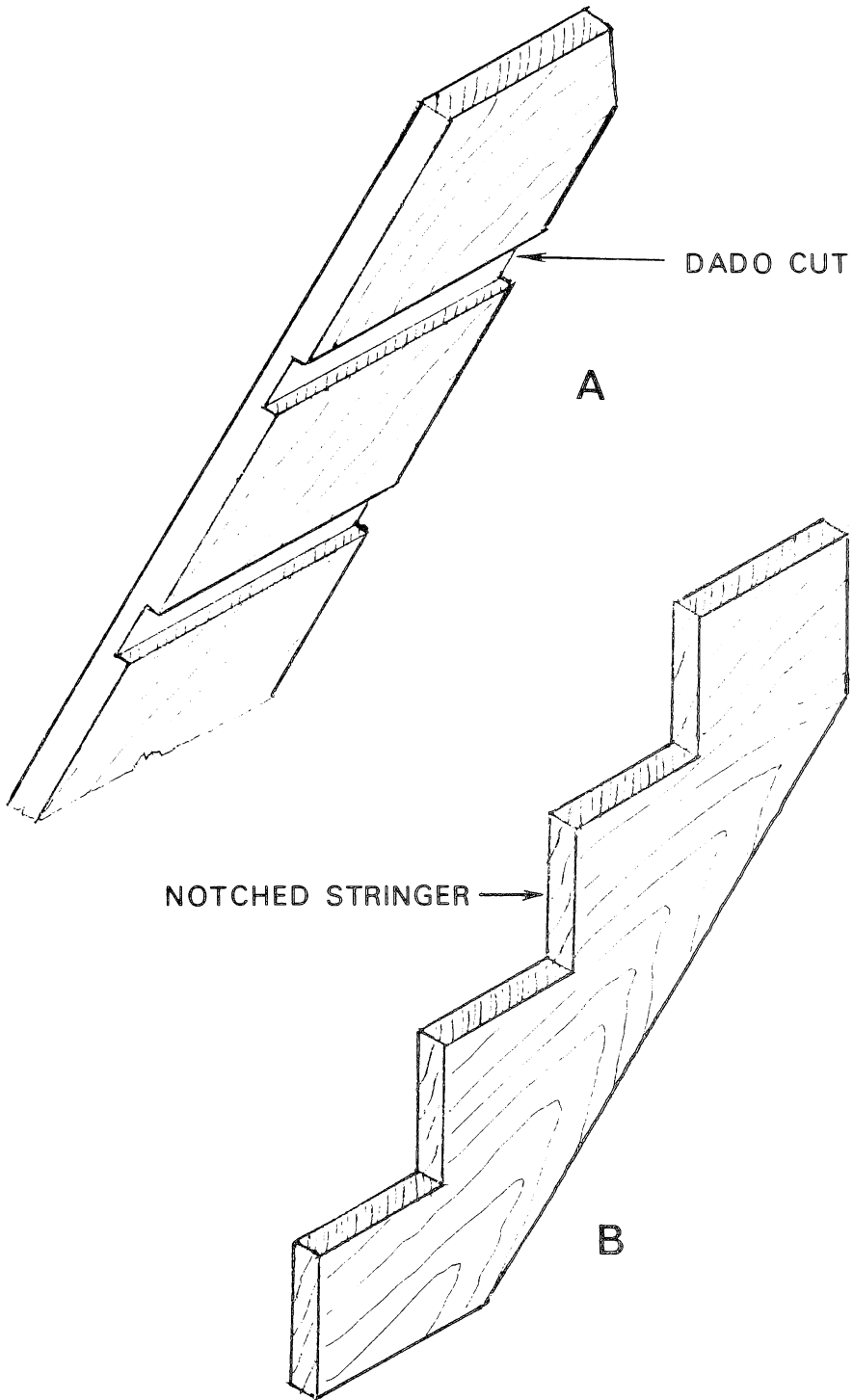

Figure 55. — Tread supports (not recommended). A — dadoed stringer (poor practice); B — notched (better practice).

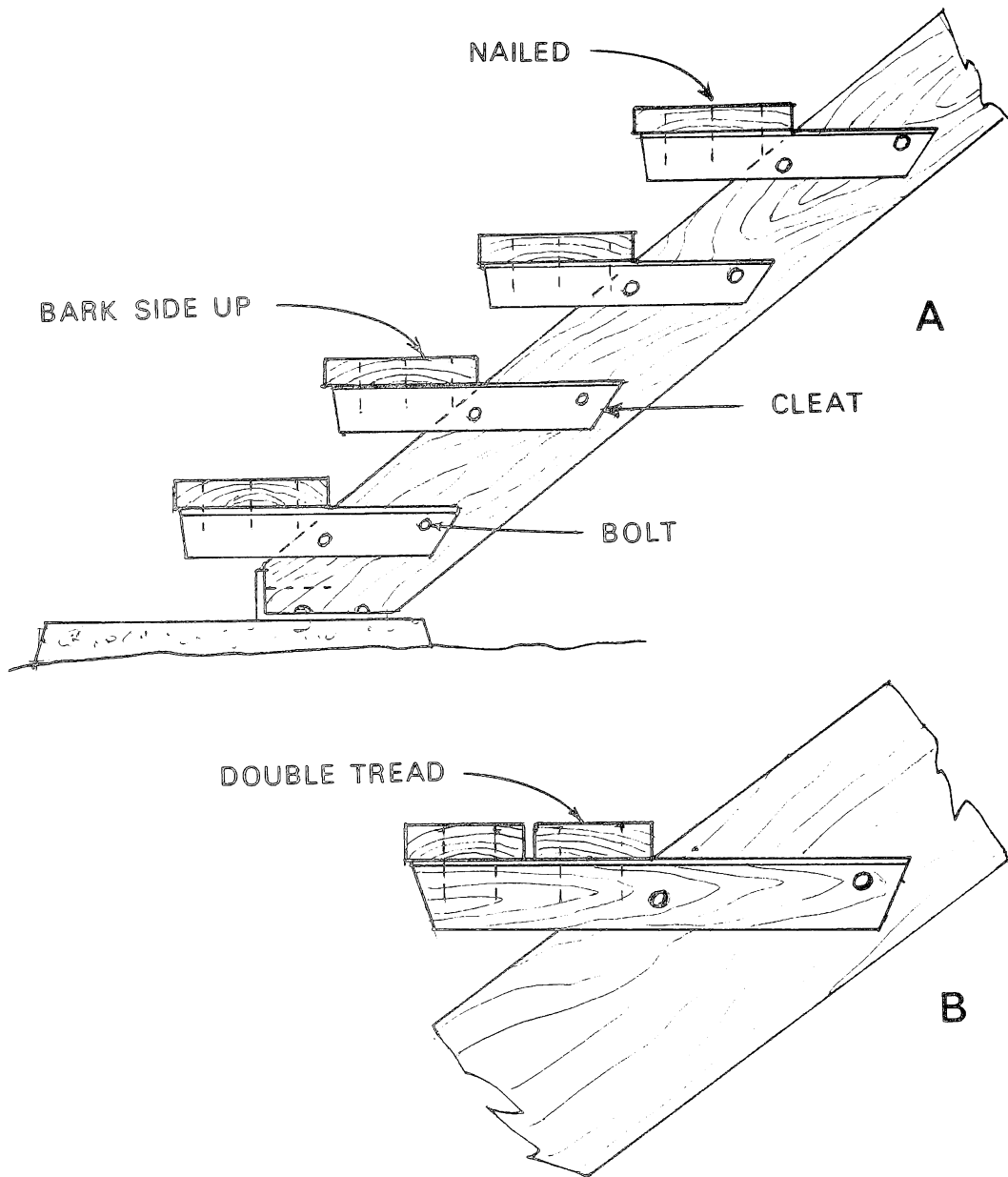

Figure 56. — Stairways with cleat support. A — extended cleat with single tread (good practice); B — double tread (better practice); C — nailed cleat (poor practice).

is by nailing them directly to the stair stringers (fig. 56C). Use 2- by 3-inch or 2-by 4-inch cleats and fasten with three or four 12^d deformed shank nails. Treads are then nailed to the cleats in a normal manner. This method is not as resistant to exposure as the extended cleat shown in fig. 56A, because there are more areas for trapped moisture. However, with the use of a decay-resistant species and water-repellent preservative treatment, good service should result.

Stair railings. — On moderate to full height stairs with one or both sides unprotected, some type of railing is advisable. Railings for stairs are constructed much the same as railings for the deck. In fact, from the standpoint of appearance, they should have the same design. Railings normally consist of posts fastened to stair stringers and supplementary members such as top and intermediate rails.

One method similar to a deck rail uses widely spaced posts and protective railings (fig. 57). Posts are 2- by 4-inch members when spacing is no more than 3 feet and 3- by 4-inch or 2- by

6-inch members for spacings from 3 to 6 feet. Longitudinal cap rails, top and intermediate, are normally 2- by 4-inch or wider members. Assembly should be with bolts or lag screws. The cap rail can be nailed to the top rail with 12^d deformed shank nails spaced 12 to 16 inches apart.

The design shown in fig. 58 has closely spaced posts which serve as balusters. Each should be bolted to the stringer and to a top rail. The cap rail which also protects the baluster ends can then be nailed to the adjoining rail.

A single cap railing can also be used for such stairs, but it is advisable to fasten it to the posts with metal clips or angles to eliminate unreliable end-grain fastening.

Many other variations of post and rail combination can be used. All designs should consider safety and utility as well as a pleasing appearance. A well-designed deck, railing, and stairway combination with care in details will provide years of pleasure with little maintenance.

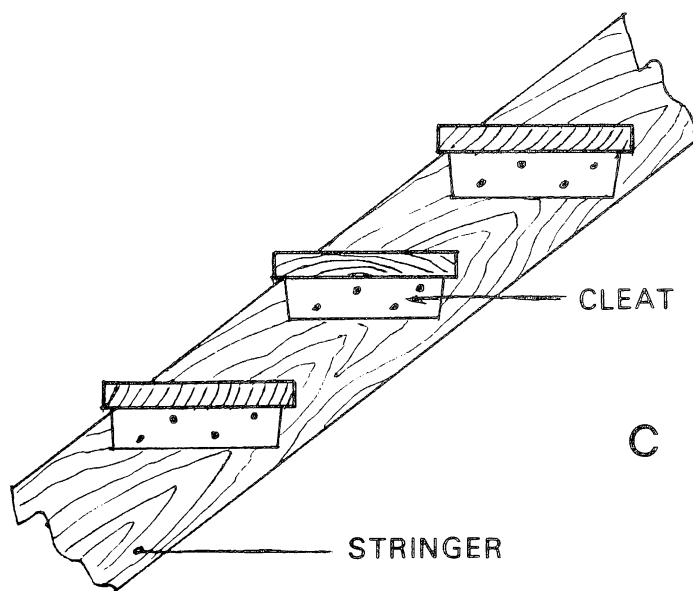

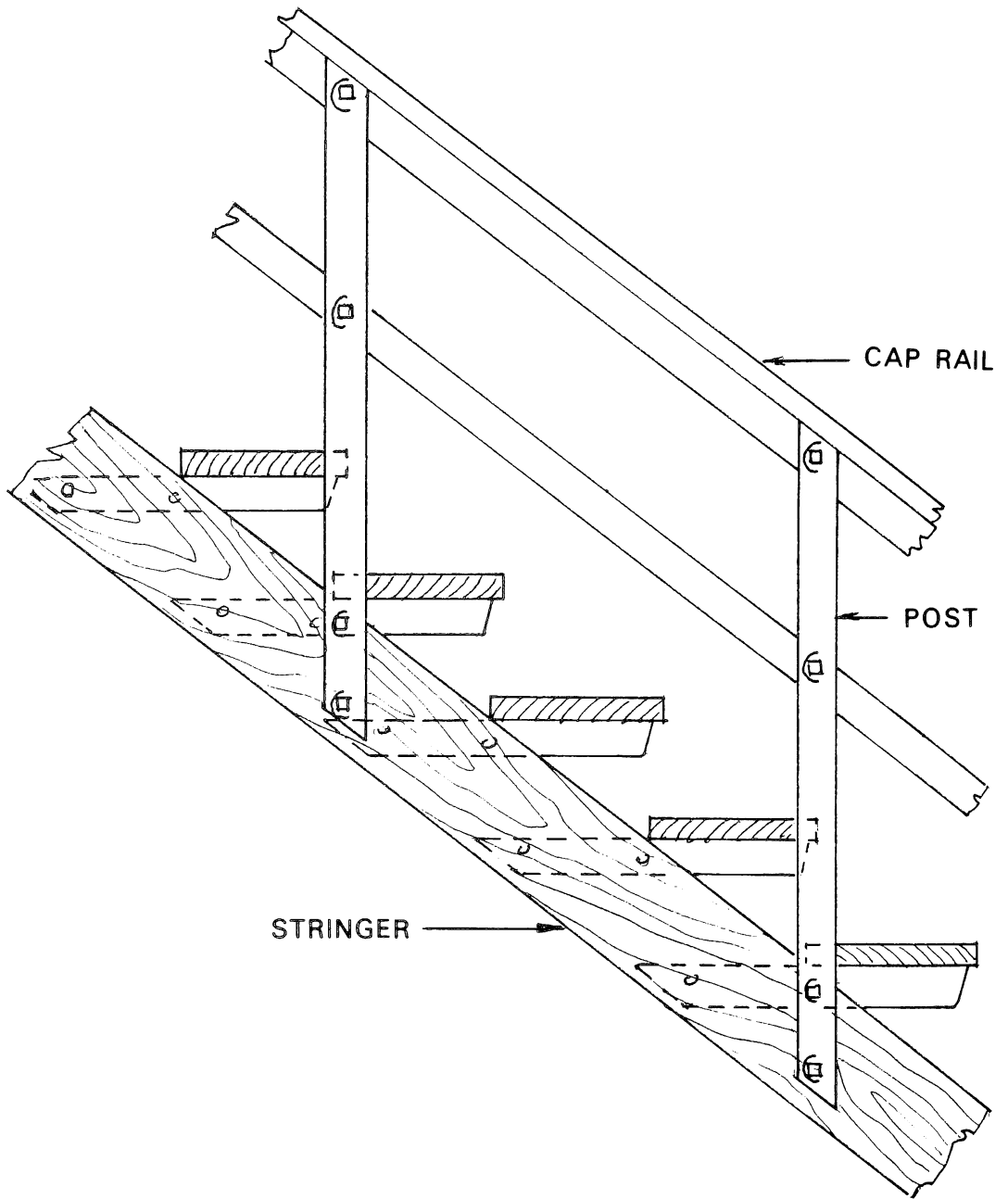

Figure 57. — Widely spaced stair posts.

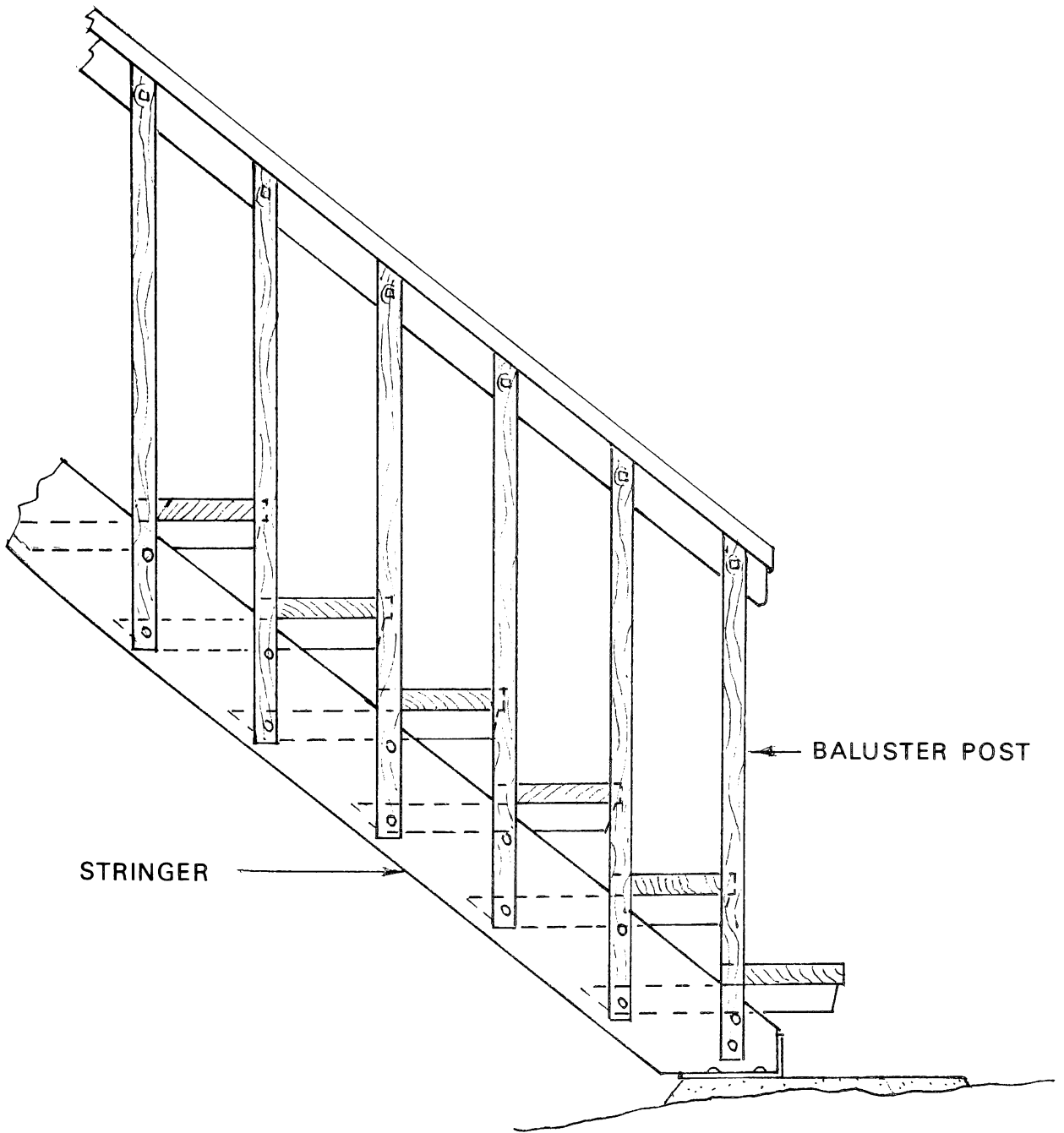

Figure 58. — Baluster-type stair posts.

References

- (1) American Institute of Timber Construction. 1966. Timber construction manual. Englewood, Colo. 80110.
- (2) American Wood-Preservers' Association. AWP standards. (Revised as needed.) Washington, D. C. 20005.
- (3) Anderson, L. O. 1967. Selection and use of wood products for home and farm building. Agriculture Information Bulletin No. 311. U. S. Government Printing Office, Washington, D. C. 20402.
- (4) California Redwood Association. 1971. Redwood decks. San Francisco, Calif. 94111.
- (5) Lane Book Co. 1963. How to build decks for outdoor living. Menlo Park, Calif. 94025.
- (6) Southern Forest Products Association. n.d. Decks . . . Patios . . . Fences. Technical Bulletin No. 14. Metairie, La. 70002.
- (7) U. S. Department of Agriculture. 1970. Forest Products Laboratory natural finish. Research Note FPL-046. Forest Products Laboratory, Forest Service, Madison, Wis. 53705.
- (8) _____ 1966. Wood finishing: painting outside wood surfaces. Research Note FPL-0123. Forest Products Laboratory, Forest Service, Madison, Wis. 53705.
- (9) _____ 1955. Wood handbook. Agriculture Handbook No. 72. U. S. Government Printing Office, Washington, D. C. 20402.
- (10) U. S. Department of Commerce. 1966. U. S. Product Standard PS 1-66 for softwood plywood. National Bureau of Standards, Washington, D. C. 20230. Also available from American Plywood Association, Tacoma, Wash. 98401.
- (11) U. S. Department of Housing & Urban Development. 1967. FHA pole house construction. Washington, D. C. 20402.
- (12) Verrall, Arthur F. 1966. Building decay associated with rain seepage. U. S. Department of Agriculture, Forest Service, Technical Bulletin 1356, U. S. Government Printing Office, Washington, D. C. 20402.
- (13) Western Wood Products Association. n.d. Western wood decks. Portland, Oregon 97204.

Glossary

acrylic resin — a thermoplastic resin used in latex coatings (see latex paint).

air-dried — dried by exposure to air, usually in a yard, without artificial heat.

alkyd resin — one of a large group of synthetic resins used in making latex paints.

baluster — small vertical member in a railing, between a top rail and a stair tread or bottom rail.

bending strength — the resistance of a member when loaded like a beam.

butt joint — the junction where the ends of two members meet in a square-cut joint.

cant strip — a piece of lumber triangular in cross section, used at the junction of a flat deck and a wall to avoid a sharp bend and possible cracking of the covering which is applied over it.

caulk — to make a seam watertight by filling it with a waterproofing compound.

countersink — to set the head of a nail or screw at or below the surface.

creosote — a distillate of coal tar produced by high temperature carbonization of bituminous coal; it consists principally of liquid and solid aromatic hydrocarbons; used as a wood preservative.

dado cuts — rectangular grooves in a board or plank.

dead load — load imposed by the weight of the materials that make up the structure.

decay — the decomposition of wood or other substance by fungi.

elastomeric — having elastic, rubber-like properties.

flashing — sheet metal or other material used in construction to protect from water seepage.

grouted — filled with a mortar thin enough to fill the spaces in the concrete or ground around the object being set.

gusset plate — a flat wood, plywood, or similar type member used to provide a connection at intersection of wood members.

header — a beam placed perpendicular to joists and to which joists are nailed in framing.

heartwood — older wood from the central portion of the tree. As this wood ceases to participate in the life process of the tree, it undergoes chemical changes that often impart a resistance to decay and a darkening in color.

kiln-dried — dried in a kiln with the use of artificial heat.

lag screws — large screws with heads designed to be turned with a wrench.

latex paint — a coating in which the vehicle is a water emulsion of rubber or synthetic resin.

ledger — a strip of lumber nailed along the side of a girder or wall, on which joists rest.

liquified gas — a carrier of wood preservatives, this is a hydrocarbon that is a gas at atmospheric pressure but one that can be liquified at moderate pressures (similar to propane).

live load — load superimposed on the structure by occupancy, furniture, snow, etc.

moisture content — the amount of water contained in wood, expressed as a percentage of the weight of the oven-dry wood.

neoprene — a synthetic rubber characterized by superior resistance to oils, gasoline, and sunlight.

non-leachable — not dissolved and removed by the action of rain or other water.

pentachlorophenol (penta) — a chlorinated phenol, usually in petroleum oil, used as a wood preservative.

penta grease — a penta-petroleum emulsion system suspended in water by the use of emulsifiers and dispersing agents.

Plugged Exterior — a grade of plywood used

for subfloor underlayment. The knot holes in the face plys are plugged and the surface is touch-sanded.

primer or prime coat — the first coat in a paint job that consists of two or more coats. The primer may have special properties that provide an improved base for the finish coat.

racking resistance — a resistance to forces in the plane of a structure that tend to force it out of shape.

silicone — one of a large group of polymerized organic siloxanes that are available as resins, coatings, sealants, etc., with excellent water-proofing characteristics.

stiffness — resistance to deformation by loads that cause bending stresses.

superstructure — the structural part of the deck above the posts or supports.

T&G — tongue and grooved joining of ends or edges.

Underlayment Exterior — see Plugged Exterior.

water-repellent preservative — a liquid designed to penetrate into wood and impart water repellency and a moderate preservative protection. It is usually applied by dipping.