

THE STEEL SQUARE AND ITS USES

A COMPLETE, UP-TO-DATE ENCYCLOPEDIA ON THE PRACTICAL USES OF THE STEEL SQUARE, SHOWING HOW IT CAN BE USED BY THE CARPENTER IN HIS DAILY WORK, TOGETHER WITH A DETAILED DISCUSSION OF THE VARIOUS DEVICES NOW ON THE MARKET WHICH AIM TO SIMPLIFY THE WORK WHICH CAN BE DONE WITH THIS WONDERFUL TOOL

IN TWO VOLUMES

EDITED UNDER THE SUPERVISION OF

WILLIAM A. RADFORD

EDITOR-IN-CHIEF OF THE "AMERICAN CARPENTER AND BUILDER," PRESIDENT OF "THE RADFORD ARCHITECTURAL CO.," AND THE BEST AUTHORITY IN THE COUNTRY ON ALL THINGS PERTAINING TO THE BUILDING TRADE

ASSISTED BY

ALFRED W. WOODS

ASSOCIATE EDITOR OF THE "AMERICAN CARPENTER AND BUILDER," INVENTOR OF "WOODS' KEY TO THE STEEL SQUARE," AND THE RECOGNIZED "WORLD'S GREATEST EXPERT WITH THE STEEL SQUARE."

AND

WILLIAM REUTHER

EDITOR OF THE "AMERICAN CARPENTER AND BUILDER," AND ONE OF THE MOST THOROUGH AND PRACTICAL WRITERS ON MODERN BUILDING METHODS.

VOLUME I.

NEW YORK
PUBLIC
LIBRARY

INDUSTRIAL PUBLICATION CO.
19 THOMAS STREET, NEW YORK

THE NEW YORK
PUBLIC LIBRARY
ASTOR, LENOX AND
TILDEN FOUNDATIONS.

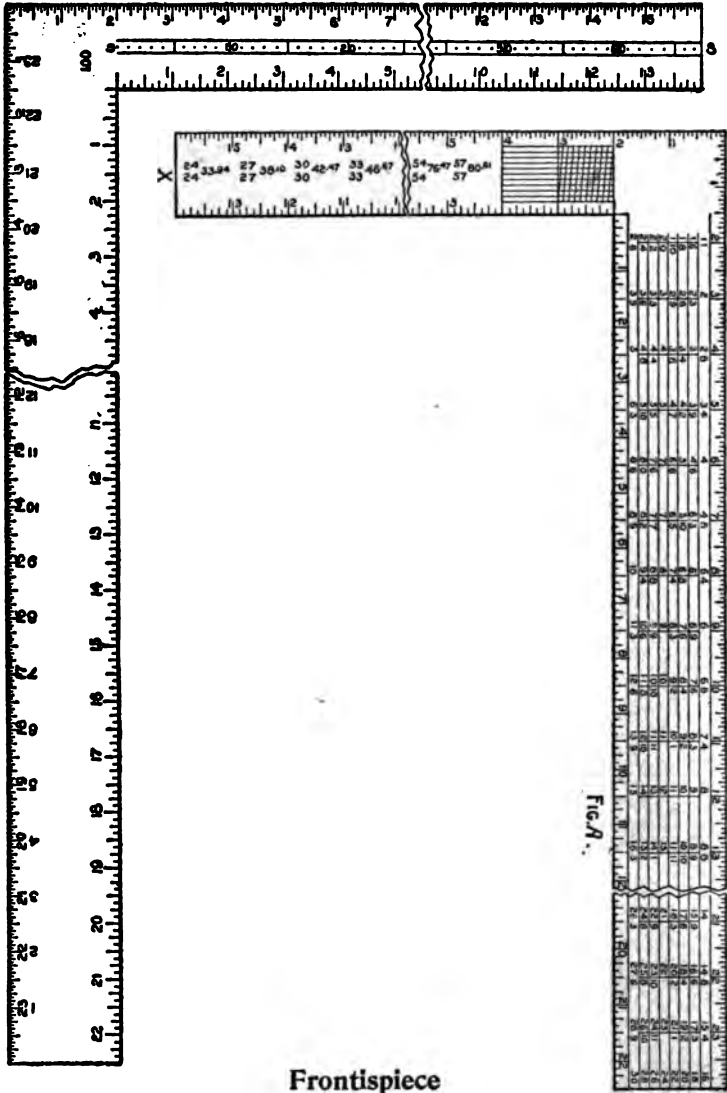

THE NEW YORK
PUBLIC LIBRARY
412410
ASTOR, LENOX AND
TILDEN FOUNDATIONS.
R 1907 L

COPYRIGHT, 1907
BY
WILLIAM A. RADFORD
CHICAGO

WILLIAM A. RADFORD
CHICAGO
1907

CONTENTS

PART I—Preliminary

What is Needed to Excel—Open Ways to Knowledge—The Finished Workman—Uses of the Steel Square 13

PART II—Historical and Descriptive

Square Used by Earliest Builders—Description of the Steel Square—How to Test the Square—Uses of the Figures, Lines and Scales—The Diagonal Scale—Board, Plank, and Scantling Measure—Brace Rule—Octagonal Scale 19

PART III—The Adjustable Fence

A Necessary Appendage—Application of the Fence—Formation of a Brace 33

PART IV—Roof Framing

Rafters—Laying Out a Rafter—Pitches and Fractions—How to Get the Bevels—Roof Pitches Explained—Reversed Pitches—Irregular, Uneven or Unequal Pitches—Projecting Cornices—To Find the Length of Rafters Where the Rises in the Roof are of Different Height—The Pitch of the Tower Roof—Hip Rafters—Length of Hip Rafters—How to Get the Inches and Fractions—Valley Rafters for Gables—Curved Hip Rafters—Common Rafters—To Find the Length and Cut of Rafters—The Measurement Line of Hips and Valleys—An Unequal Pitch—To Find the Length of the Jacks 40

PART V—Hip Roof Framing

A Formula in Figures—Side Cut of the Hip—Beveling of Hip Rafter—To Cut Bed Moulds—The Principles to be Determined in a Hip Roof—To Find the Backing of a Hip Rafter—How to Find the Shoulder of Purlins—How to Pierce a Circular Roof With a Saddle Roof—Illustration of Roof Pitches—Reckoning by Degrees—Decimal Equivalents—Framing by Degrees—How to Find the Length of the Rafters to a Given Scale, Also the Bevels That Give the Cuts—Octagonal Roofs—Lengths and Bevels of Hips and Jacks—To Obtain Length of Various Rafters for Any Width of Building—Different Kinds of Jacks Described—Hexagonal Roofs—To Timber Hexagonal Roofs..... 79

PART VI—Hoppers and Hopper Bevels

Laying Out Hopper Bevels with a Square—The Various Classes of Hoppers—Methods of Finding the Bevels and Width of Sides and Ends of a Square Hopper—Rule for Finding the Bevels for the Butt Joint of the Hopper—Cuts and Bevels for Flaring Hopper—Angles and Bevels for Hopper Work—Miter—Methods of Finding the Miter—Trusses—Tower for Windmill, etc. 116

PART VII—Stair Building

How to Determine the Height and Run—Illustrations of the Pitch Board—Open Strings—Risers and Treads—Housed or Closed Stairs—Other Methods of Making a Stair String—Connecting and Affixing Strings—Balusters—Brackets—Finish of Wall String at Foot of Stairs—Finish of Wall String at Top of Stairs—Open String at Foot of Stairs. 153

PART VIII — Combination Squares

Universal Square—Hight's Union Combination Square—Ideal Bevel
Try-Square—Topp's Framing Tool 181

PART IX — Key to Steel Square

The Rafter Table — Lengths and Cuts for One-third Pitch — Side
Cut of Jack — Side Cut of Octagon Jack — Side Cut of Hip
or Valley — Table of Tangents — To Find Miter for any
Regular Polygon — To Draw a Five-Pointed Star — To
Frame Timbers at any Degree of Pitch — The Curve for an
Octagon Hip — To Find Shape of Jack — To Find Backing
for a Curved Hip 187

PART X — Possibilities of the Steel Square

Polygon Family Circle — Laying out a Circular Frame — Framing
to Any Degree — Ornamental Figures in Miter Work —
Arrangement of the Triangle — Application of Degrees —
Drawing a Heptagon — Tangents and Co-Tangents — Degree
Line of Triangle and Hexagon — Laying Off Degrees with
Compasses — Foundation of Miters — Fractional Value of
Decimals 209

PREFACE

The purpose of the present work is to supply the need for a complete treatise on the modern Steel Square, that wonder-working tool, a superior knowledge of which has enabled the American artisan to surpass his fellow workman of all other countries in the attainment of the highest standard of skill.

Many able articles on the uses and possibilities of the Steel Square have from time to time appeared in the leading mechanical and building journals of the country, and some of the more interesting and instructive of them have been republished in book form, together with much additional valuable information, specially prepared by the able authors and compilers of the books.

But this, it is believed, is the first attempt at supplying the demand for a complete and systematic treatise on the subject. The fundamental principles of the square are herein given in plain language, with explanatory illustrations, and so methodically arranged that every workman who makes use of the square can have easy access to such knowledge of its use as he may at any time require.

The aim has been to make the work not merely an instructive treatise, but a practical aid to those

who may have occasion to solve any problem within the possibilities of the Steel Square.

The application of the rules given for finding the lengths and bevels of boards and timbers, and for the various uses of roof framing, hopper work and stair building, is made so plain by means of simple language and graphic illustrations, as to enable the workman of average capacity to grasp the meaning at a glance.

The text is methodically arranged in progressive chapters, a full list of the contents of each chapter being given at its head. All the valuable helps and hints, and the rules and examples contained in the work, are placed under appropriate sub-headings, with index commencement words printed in bold-faced type, so that the eye of the reader can catch the particular information wanted at once.

Original illustrative diagrams, to the number of over two hundred, are contained in the work, including many full-page illustrations, communicating information in a manner as clear and distinct as it is interesting and instructive.

The collection of miscellaneous rules and examples given in Volume II, illustrating uses of the square, is the most complete ever made. To make the rules of practical utility, one example under each rule is worked out, each distinct operation in the process being clearly shown by means of an illustrative diagram. Great care has been taken to secure absolute accuracy, and to plainly exhibit the practical application of

the principles of the square to the actual everyday problems of the carpenter and builder. It is hoped and earnestly believed, that in this treatise, the aspiring young artisan will find a helpful textbook of instruction, and the practical workman an up-to-date ready reference guide to the skillful use of the American artisan's most helpful constructive instrument — the modern Steel Square.

The department of Questions and Answers in Volume II is one of the most useful, interesting and instructive parts of this work. In this part numerous questions, which have been sent the editors by practical carpenters all over the country, have been fully answered. They are questions which come up in your work every day, and the solutions of these practical problems here given will prove a valuable aid to you.

WILLIAM A. RADFORD,
Chicago, Ill.

The Steel Square

And Its Uses

Part I

PRELIMINARY

What is Needed to Excel—Open Ways to Knowledge—The
Finished Workman—Uses of the Steel Square

THERE is nothing of more importance to a young man who is learning the business of house-joinery and carpentry, than that he should make himself thoroughly conversant with the capabilities of the tools he employs. It may be that in some cases under the rules shown in this work the result can be obtained much more readily with other aids than the square; but the progressive mechanic will not rest satisfied with one method of performing operations when others are within his reach.

In the hand of the intelligent mechanic the square becomes a simple calculating machine of the most wonderful capacity, and by it he solves problems of the kinds continually arising in mechanical work, which by the ordinary methods are more difficult to perform.

What Is Needed to Excel.—The great improvement which the arts and manufactures have attained within the last fifty years, renders it essential that every person engaged therein should use his utmost exertions to obtain perfect knowledge of the trade he professes to follow. It is not enough, nowadays, for a person to have attained the character of a good workman; that phrase implies that quantum of excellence, which consists in working correctly and neatly, under the directions of others. The workman of to-day, to excel, must understand the principles of his trade, and be able to apply them correctly in practice. Such a one has a decided advantage over his fellow-workman; and if besides his superior knowledge he possesses a steady manner, and industrious habits, his efforts cannot fail of being rewarded.

It is no sin not to know much, though it is a great one not to know all we can, and put it all to good use. Yet, how few mechanics there are who will know all they can. Men apply for employment daily who claim to be finished mechanics and profess to be conversant with all the ins and outs of their craft, and who are noways backward in demanding the highest wages going, who, when tested, are found wanting in knowledge of the simplest formulas of their trade. They may, perhaps, be able to perform a good job of work after it is laid out for them by a more competent hand, they may have a partial knowledge of the uses and application of their tools; but, generally,

their knowledge ends here. Yet some of these men have worked at this trade or that for a third of a century, and are to all appearances, satisfied with the little they learned when they were apprentices. True, mechanical knowledge was not always so easily obtained as at present, for nearly all works on the constructive arts were written by professional architects, engineers, and designers, and however unexceptionable in other respects, they were generally couched in such language, technical and mathematical, as to be wholly unintelligible to the majority of workmen; and instead of acting as aids to the ordinary inquirer, they enveloped in mystery the simplest solutions of everyday problems, discouraging nine-tenths of the workmen on the very threshold of inquiry, and causing them to abandon further efforts to master the intricacies of their respective trades.

Open Ways to Knowledge.—Of late years a number of books have been published, in which the authors and compilers have made commendable efforts to simplify matters pertaining to the arts of carpentry and joinery, and the mechanic of today has not the difficulties of his predecessors to contend with. The workman of old could excuse his ignorance of the higher branches of his trade, by saying that he had no means of acquiring a knowledge of them. Books were beyond his reach, and trade secrets were guarded so jealously, that only a limited few were allowed to know them, and unless he was made of better stuff than

his fellow-workmen, he was forced to plod on in the same groove all his days.

Not so with the mechanic of today; if he is not well up in the minutiae of his trade, he has but himself to blame, for although there is no royal road to knowledge, there are hundreds of open ways to obtain it; and the young mechanic who does not avail himself of one or other of these ways to enrich his mind, must lack energy, or be altogether indifferent about his trade, and may be put down as one who will never make a workman.

The Finished Workman.—It has been thought that it would not be out of place to preface this work on the Steel Square, with the foregoing remarks, in the hope that they may stimulate the young mechanic, and urge him forward to conquer what at best are only imaginary difficulties. A willing heart and a clear head will most assuredly win honorable distinction in any trade, if they are only properly used. Indeed, during an experience of many years in the employment and superintendence of mechanics of every grade, from the green "wood-haggler" to the finished and accomplished workman, we have invariably discovered that the finished workman was the result of persistent study and application, and not, as is popularly supposed, a natural or spontaneous production. It is true that some men possess greater natural mechanical abilities than others, and consequently a greater aptitude in grasping the principles that underlie the construc-

tive arts; but as a rule, such men are not reliable; they may be expert, equal to any mechanical emergency and quick at mastering details, but they are seldom thorough, and never reliable where long-sustained efforts are required.

• The mechanic who reaches a fair degree of perfection by experience, study and application, is the man who rises to the surface, and whose steadiness and trustworthiness force themselves on the notice of employers and superintendents. We have said this in order to give encouragement to those young mechanics who find it uphill work to master the intricacies of the various arts they are engaged in, for they may rest assured that in the end work and application will be sure to win; and we are certain that a thorough study of the Steel Square and its capabilities will do more than anything else to aid the young workman in mastering many of the mechanical difficulties that will confront him from time to time in his daily occupation.

Uses of the Steel Square.—It must not be supposed that the work here presented exhausts the subject. The enterprising mechanic will find opportunity for using the square in the solution of many problems that will crop up during his daily work, and the principles herein laid down will aid very much towards correct solutions. In framing roofs, bridges, trestle-work, and constructions of timber, the Steel Square is a necessity to the American carpenter; but only a few of the more intelligent workmen ever use it for

other purposes than to make measurements, lay off the mortices and tenons, and square over the various joints. Now, in framing bevel work of any description, the square may be used with great advantage and profit. Posts, girts, braces, and struts of every imaginable kind may be laid out by this wonderful instrument, if the operator will only study the plans with the view of making use of his square for obtaining the various bevels, lengths and cuts required to complete the work in hand. Tapering structures—the most difficult the framer meets with—do not contain a single bevel or length that cannot be found by the square when properly applied, and it is this fact we wish to impress on our readers, for it would be impossible in this work, to give every possible application of the square to work of this kind. We have therefore, only given such examples as will enable any one to apply some one of them to any work in hand.

Doubtless, in the early ages of mankind, when solid structures became a necessity, the want of an instrument similar to a square must have been felt at every “turn and corner,” and there can be no question about one having been used—rude and imperfect perhaps—in erecting the first square or rectangular building that was ever built on this earth.

Part II

HISTORICAL AND DESCRIPTIVE

Square Used by Earliest Builders—Description of the Steel Square—How to Test the Square—Uses of the Figures, Lines and Scales—The Diagonal Scale—Board, Plank, and Scantling Measure—Brace Rule—Octagonal Scale

Square Used by the Earliest Builders.—The Greeks, who were an inventive people, and who were apt to ascribe to themselves more credit than was really their due, in the way of inventions and discoveries, lay claim to be the inventors of the instrument. Pliny says that Theodorus, a Greek of Samos, invented the square and level. Theodorus was an artist of some note, but it is evident that the square and level, in some form or other, were used long before his time, even in his own country, for some of the finest temples in Athens and other Grecian cities, had been built long before his time; and the Pyramids of Egypt were hoary with age when he was in swaddling cloths. Indeed, the "square," as a constructive tool, must of necessity have found a place in the "kit" of the earliest builders. Evidences of its presence have been found in the ruins of pre-historic nations, and are abundant in the remains of ancient Petra, Ninevah, Babylon, Etruria, and India. South American ruins of great antiquity in Brazil, Peru, and other places, show that the

unknown races that once inhabited the South American Continent, were familiar with many of the uses of the square. Egypt, however, that cradle of all the arts, furnishes us with the most numerous, and, perhaps, the most ancient evidences of the use of the square; paintings and inscriptions on the rock-cut tombs, the temples, and other works, showing its use and application, are plentiful. In one instance, a whole "kit" of tools was found in a tomb at Thebes, which consisted of mallets, hammers, bronze nails, small tools, drills, hatchets, adzes, squares, chisels, etc.; one bronze saw and one adze have the name of Thothmes III, of the 18th dynasty stamped on their blades, showing that they were made nearly 3,500 years ago. The constructive and decorative arts at that time were in their zenith in Egypt, and must have taken at least 1,000 years to reach that stage. Consequently, the square must have been used by the workmen of that country, at least, four thousand years ago.

The British Museum contains many tools of pre-historic origin, and the square is not the least of them. Herculaneum and Pompeii contribute evidences of the importance of this useful tool. On some of the paintings recently discovered in those cities, the different artisans can be seen at work in their own workshops, with their work benches, saw-horses, tools, and surroundings, much about the same as we would find a small carpenter shop of today, where all the work is done by hand; the only difference being a change

in the form of the tools, which, in some instances, had been better left as these old workmen devised them.

It can make no difference, however, to the modern workman, as to when or where the square was first used; suffice to know, that at present, we have squares immensely superior to anything known to the ancients, and it may be added, that so perfect has the machinery for the manufacture of steel squares become, that a defective tool is now the exception. Of course this relates to the products of manufacturers of repute, and not to the cheap squares, or to those said to be first class, that were made ten or fifteen years ago. The tool we recommend in this book is the best made, both as to quality of material, accuracy of workmanship, and amount of useful matter on its faces.

Description of the Square.—In the foregoing sketch we have given a few hints as to the kind of square to buy; in many cases, however, this book will find its way into the hands of mechanics and others, who have old and favorite squares in their chests or workshops, and who will not care to dispose of a “well tried friend” for the purpose of filling its place with another simply because we have recommended it. To these workmen we would say we do not advise a change provided the old square is true, and the inches and subdivisions are properly and accurately defined. We wish it distinctly understood that old squares, if true, and marked with inches and sub-divisions

of inches, will perform nearly every solution presented in this book.

The lines and figures formed on the squares of different make, sometimes vary, both as to their position on the square, and their mode of application, but a thorough understanding of the application of the scales and lines shown on any first-class tool, will enable the student to comprehend the use of the lines and figures exhibited on other first-class squares.

To insure good results, it is necessary to be careful in the selection of the tool.

The blade of the square should be 24 inches long, and two inches wide, and the tongue from 14 to 18 inches long and $1\frac{1}{2}$ inches wide. The tongue should be exactly at right angles with the blade, or in other words the "square" should be perfectly square.

How to Test the Square.—To test this question, get a board, about 12 or 14 inches wide, and four feet long, dress it on one side, and true up one edge as near straight as it is possible to make it. Lay the board on the bench, with the dressed side up, and the trued edge toward you, then apply the square, with the blade to the left, and mark across the prepared board with a pen-knife blade, pressing close up to the edge of the tongue, and then reverse the square, and move it until the tongue is close up to the knife mark; if you find that the edge of the tongue and the mark coincide, it is a proof that the tool is correct enough for your purposes.

This, of course, relates to the inside edge of the blade, and the outside edge of the tongue. If these edges should not be straight or should not prove perfectly true, they should be filed or ground until they are straight or true. The outside edge of the blade should also be "trued" up to make it exactly parallel with the inside edge, if such is required. The same process should be gone through on the tongue. As a rule, squares made by firms of repute are perfect, and require no adjusting; nevertheless, it is well to make a critical examination before purchasing.

Use of the Figures, Lines, and Scales.—The next thing to be considered is the use of the figures, lines, and scales, as exhibited on the square. It is supposed that the ordinary divisions and sub-divisions of the inch, into halves, quarters, eighths, and sixteenths are understood by the student; and that he also understands how to use that part of the square that is sub-divided into twelfths of an inch. This being conceded, we now proceed to describe the various rules as shown on all good squares; but before proceeding further, it may not be out of place to state, that on the tool recommended in this book, one edge is subdivided into thirty-seconds of an inch.

This fine sub-division will be found very useful, particularly so when used as a scale to measure drawings made in half, quarter, one-eighth, or one-sixteenth of an inch to the foot.

The Diagonal Scale.—In Fig. 1 we show a diagram of the diagonal scale enlarged and lettered for this occasion; and we may here state that the workman will find no difficulty in adapting the diagrams and what follows to the scale as depicted on his own square.

From the numerous inquiries we have had we are led to believe that the diagonal scale, of which the accompanying figure is a diagram, is not so well understood or appreciated as it ought

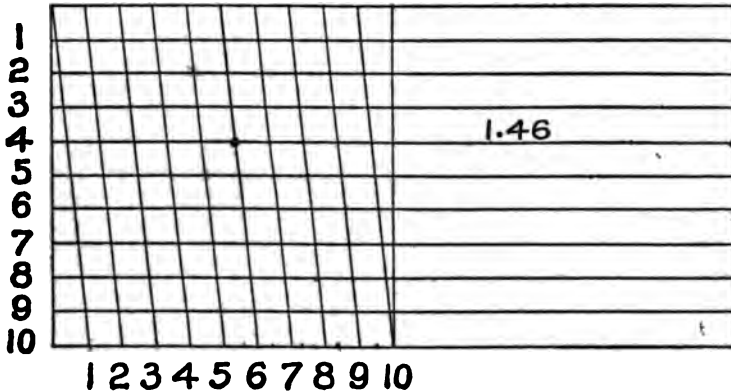

FIG. 1

to be, which is certainly to be regretted. This scale is for minute measurements, and when a thorough knowledge of its properties is understood, it is not a very difficult operation to so employ it that the 100th part of an inch may be obtained, and for practical workman this is minute enough, though to the advanced scientist this would be a trifling operation, when such minute

measurements are used as the 5000th part of an inch.

In actual practice the scale is never used to find the smaller measurements, but it may sometimes happen that the workman may want to measure a plan or take a distance on a map very accurately, then a fine subdivision will be found useful.

In order to give the reader a fair understanding of the principles on which this scale is founded, we illustrate its construction and the manner in which it is used, and in doing so, for convenience sake, quote from an excellent authority on the subject: "Let us draw a diagram Fig. 2, say three times the size of the first division of the scale as shown on the square. Imagine the short distance from A to B to represent ten inches; it will be evident to any one that to divide that short space into ten equal parts would simply confuse the whole diagram; but if we adopt another plan and divide into ten equal parts its length, as shown, and then draw a diagonal line from B to C, we have the distance AB divided into ten parts.

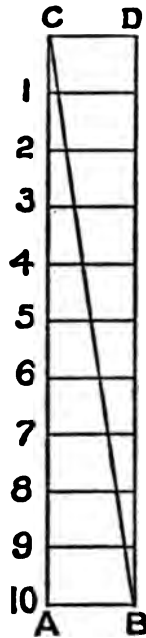

FIG. 2

The numbers shown in the diagram indicate the fractional parts of the line A B, and if we take our compasses and place one leg on the line A C, at number 5, and the other leg where the diagonal

line cuts the line 5, that distance will be found to be just one-half of the distance between A and B. There is a difference of one-tenth of the whole distance between A B, at every point where the diagonal cuts the cross lines. Or in other words, where the diagonal crosses the horizontal lines, the point of juncture is one inch nearer to the line A C, than the next point lower down.

This is the principle on which the diagonal scale is based, and it will be seen that any fraction of a foot or an inch may be so divided by diagonals that the most minute subdivisions may be obtained.

The measurements, of course, are always taken along the horizontal lines, and measured from the perpendicular to the diagonal.

With a thorough knowledge of the foregoing, it will be easy to understand that the perpendicular is not necessarily limited. It may be made twice or four times the length, and divided into twice or four times the number of parts which would render the diagram to make reading of 200ths and 400ths respectively.

If twelfths of an inch or foot are wanted, all that is required is to divide the height into twelve parts instead of ten, draw the diagonal and the twelfths are there.

In using this scale let us examine it in Fig. 1, and we will see that the other divisions are in inches, so to apply the rule we proceed as follows: For instance, we want one inch and forty-six one-hundredths, place one leg of the compasses on.

the one inch mark and the other leg where the diagonal cuts the line at 4, on the sixth division up. This gives the length required.

The foregoing description and explanation apply to the diagonal scale, as well as to the scale on a steel square, and generally accompanies a case of drawing instruments.

It may be well to state here that some new squares recently placed on the market, claim special features in the way of rafter tables, etc., but their scope in this direction is limited and cannot contain the general information that may be obtained from the Standard Steel Square as herein described.

Board, Plank and Scantling Measure.—Perhaps, with the single exception of the common inch divisions on the square, no set of figures on the instrument will be found more useful to the active workman than that known as the board rule. A thorough knowledge of its use may be obtained by ten minutes study, and, when once obtained, is always at hand and ready for use.

The following explanations are deemed sufficiently clear to give the reader a full knowledge of the workings of the rule. If we examine the Fig. A, in the Frontispiece, we will find under the figure 12, on the outer edge of the blade, where the length of the boards, plank, or scantling to be measured, is given, and the answer in feet and inches is found under the inches in width that the board, etc., measures. For example, take a board nine feet long and five inches wide;

to measure a piece of timber 25 feet long, 10 by 14 inches in size. For the length we will take 12 and 13 feet. For the width we will take 10 inches, and multiply the result by 14. By the rule a board 12 feet long and 10 inches wide contains 10 feet, and one 13 feet long and 10 inches wide, 10 feet 10 inches. Therefore, a board 25 feet long and 10 inches wide must contain 20 feet and 10 inches. In the timber, above described, however, we have what is equivalent to 14 such boards, and therefore we multiply the result by 14, which gives 291 feet and 8 inches, the board measure.

Fig. 3 shows the method now in use for board measure. This shows the correct contents in feet and inches. It is a portion of the blade of the square, as shown in the Frontispiece.

Brace Rule.—The “brace rule” is always placed on the tongue of the square, as shown in the central space at x in Fig. A, Frontispiece.

This rule is easily understood; the figures on the left of the line represent the “run” or the length of the two sides of a right angle, while the figures on the right represent the exact length of the third side of a right-angled triangle, in inches, tenths, and hundredths. Or, to explain it in another way, the equal numbers placed one above the other, may be considered as representing the sides of the square, and the third number to the right the length of the diagonal of that square. Thus the exact length of a brace from point to point having a run of 33 inches on a

post and a run of the same on a girt, is 46.67 inches. The brace rule varies somewhat in the matter of the runs expressed in different squares. Some squares give a few brace lengths of which the runs upon the post and beam are unequal.

Octagonal Scale.—The “octagonal scale,” as shown on the central division of the upper portion of blade, is on the opposite side of the square to the “brace rule,” and runs along the center of the tongue as at S S in Frontispiece. Its use is as follows: Suppose a stick of timber ten inches square. Make a center line, which will be five inches from each edge; set a pair of compasses, putting one leg on any of the main divisions shown on the square in this scale, and the other leg on the tenth subdivision. This division, pricked off from the center line on the timber on each side, will give the points for the gauge-lines. Gauge from the corners both ways, and the lines for making the timber octagonal in its section are obtained. Always take the same number of spaces on your compasses as the timber is inches square from the center line. Thus, if a stick is twelve inches square, take twelve spaces on the compasses; if only six inches square, take six spaces on the compasses, etc. The rule always to be observed is as follows: Set off from each side of the center line upon each face as many spaces by the octagon scale as the timber is inches square. For larger timbers than the number of divisions in the scale, the measurements by it may be doubled, or trebled, as the case may be.

The diagram, Fig. 4, shows the application of the rule applied to the end of a stick of timber or on a plane surface. Let B C D E, be the square equal to six inches on a side. Draw the center lines, B C, and D E, then with the dividers

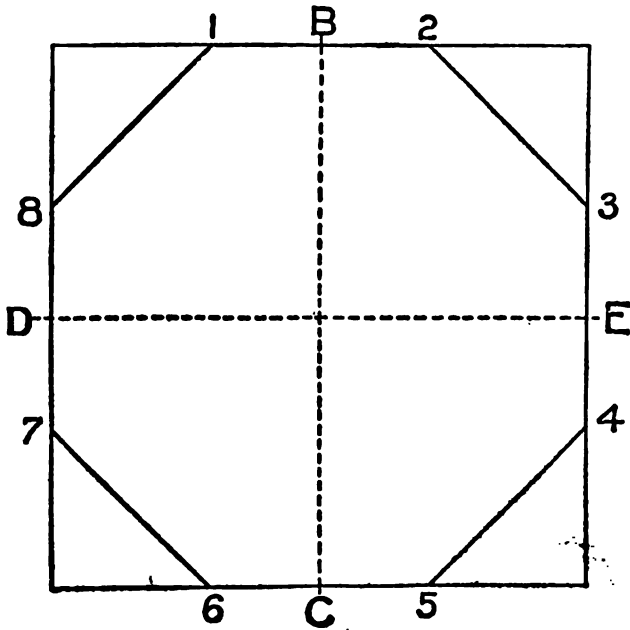

FIG. 4

take from the scale six parts, and lay off this distance from the center of each; as B1, B2, E3 and E4, C5 and C6, D7 and D8. Draw lines from 1 to 8, 2 to 3, 4 to 5, 6 to 7, and the octagon figure is complete.

A rule for laying off octagons is figured on nearly all carpenter's two-foot rules, marked off

from the inner edges of the rule; one set of figures is denoted by the letter E, another set is denoted by the letter M. The set marked E measures the distance from the edge of the square to the points indicated in the diagram, by the figures 1, 2, 3, 4, etc. The set marked M is used for finding the points 1, 2, 3, 4, etc., by measuring from the middle or center lines, B, E, C, D.

We have now fully described all the lines, figures, and scales that are usually found on the better class of squares now in use; but we may as well remark here that there are squares in use of an inferior grade, that are somewhat differently figured. These tools, however, are such as cannot be recommended for the purposes of the scientific carpenter or joiner.



Part III

THE ADJUSTABLE FENCE

A Necessary Appendage—Application of the Fence—Formation of a Brace

A Necessary Appendage to the steel square in solving mechanical problems, is what we call, for want of a better name, an adjustable fence. This is made out of a piece of hardwood 2 inches wide, and 2 feet 10 inches long (being cut so that it will pack in a tool chest), and $1\frac{1}{8}$ inches thick; run a gauge line down the center of both edges; this done, run a saw kerf cutting down these gauge lines at least one foot from each end, leaving about ten inches of solid wood in



FIG. 5

the center of fence. We now take our square and insert the blade in the saw kerf at one end of the fence, and the tongue in the kerf, at the other, the fence forming the third side of a right-angled triangle, the blade and the tongue of the square forming the other two sides. A fence may be made to do pretty fair service, if the saw kerf is all cut from one end as shown in Fig. 5. The next step will be to make provision for hold-

ing the fence tight on the square; this is best done by putting a No. 10, $1\frac{1}{2}$ -inch screw in each end of the fence, close up to the blade and tongue; having done this, we are ready to proceed to business.

Application of the Fence.—The fence being made as desired, in either of the methods mentioned, and adjusted to the square, work can be commenced forthwith.

The first attempt will be to make a pattern for a brace, for a four-foot "run." Take a piece

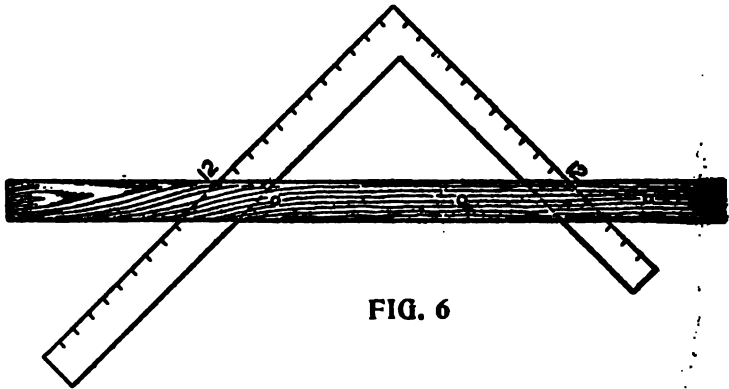

of stuff already prepared, six feet long, four inches wide and a half-inch thick.

Take the square as arranged at Fig. 6, and place it on the prepared stuff as shown in Fig. 7. Adjust the square so that the twelve-inch line coincide exactly with the gauge line 0, 0, 0, 0. Hold the square firmly in the position now obtained, and slide the fence up the tongue and blade until it fits snugly against the jointed

edge of the prepared stuff, screw the fence tight on the square, and be sure that the 12-inch marks on both the blade and the tongue are in exact position over the gauge-line.

We are now ready to lay out the pattern. Slide the square to the extreme left, as shown on the dotted lines at X, mark with a knife on the outside edges of the square, cutting the gauge-



FIG. 7

line. Slide the square to the right until the 12-inch mark on the tongue stands over the knife mark on the gauge line; mark the right hand side of the square, cutting the gauge line as before, repeat the process four times, marking the extreme ends to cut off, and we have the length of the brace and the bevels.

Square over, at each end from the gauge line, and we have the toe of the brace. The lines, S, S, shown at the ends of the pattern, represent the tenons that are to be left on the braces. This pattern is now complete; to make it handy for use, however, nail a strip 2 inches wide on its edge, to answer for a fence and the pattern can then be used either side up.

Formation of a Brace.—The cut in Fig. 8, shows the brace in position, on a reduced scale.

The principle on which the square works in the formation of a brace can easily be understood from this cut, as the dotted lines show the posi-

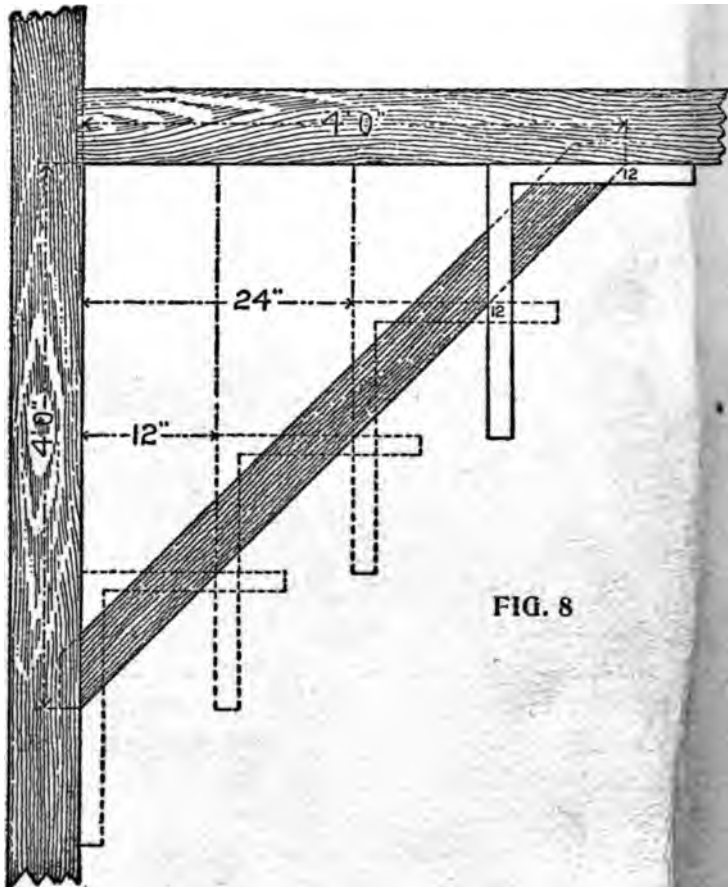

FIG. 8

tion the square was in when the pattern was laid out.

It may be necessary to state that the "square," as now arranged, will lay out a brace pattern

for any length, if the angle is right and the runs equal. Should the brace be of great length, however, additional care must be taken in the adjustment of the square, for should there be any departure from truth, that departure will be repeated every time the square is moved, and where it would not affect a short run, it might seriously affect a long one.

To lay out a pattern for a brace where the run on the beam is three feet, and the run down the post four, proceed as follows: Prepare a

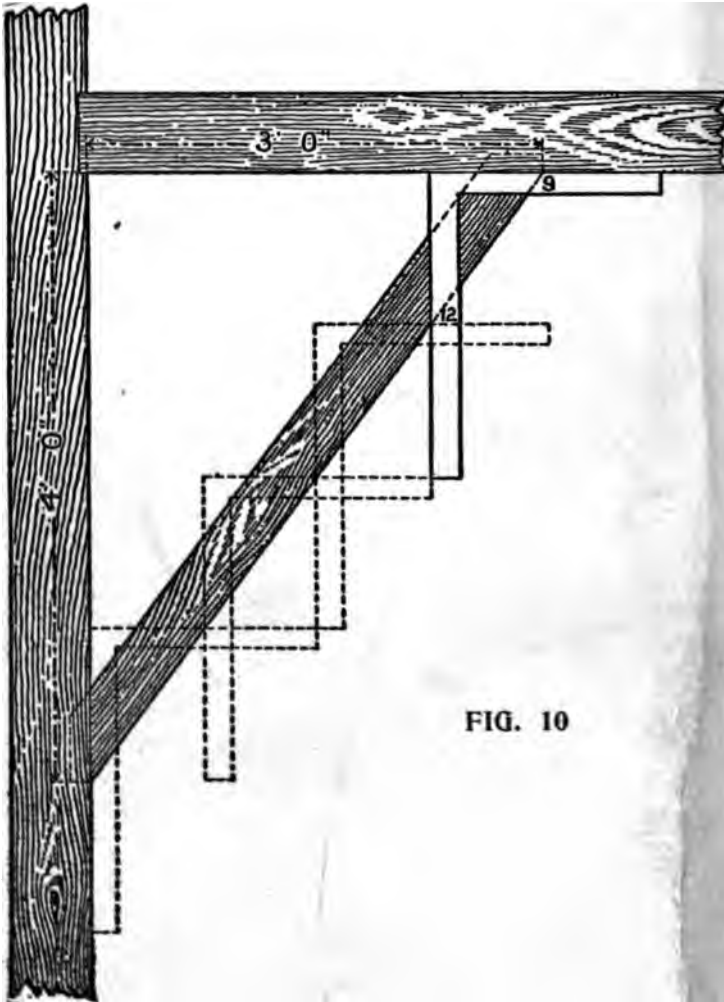

FIG. 9

piece of stuff, same as the one operated on for a four-foot run; joint and gauge it. Lay the square on the left-hand side, keep the 12-inch mark on the tongue, over the gauge line, place the nine-inch mark on the blade, on the gauge line, so that the gauge line forms the third side of the right-angled triangle, the other sides of which are nine and twelve inches respectively.

Now proceed as on the former occasion, and as shown in Fig. 9, taking care to mark the bevels at the extreme ends. The dotted lines show the positions of the square, as the pattern is being laid out.

Fig. 10 shows the brace in position, the dotted lines show where the square was placed on the



pattern. It is well to thoroughly understand the method of obtaining the lengths and bevels of

irregular braces. A little study will soon enable any person to make all kinds of braces.

If we want a brace with a two-foot run, and a four-foot run, it must be evident that, as two is the half of four, so on the square take 12 inches on the tongue, and six inches on the blade, apply four times, and we have the length, and the bevels of a brace for this run.

For a three by four-foot run, take 12 inches on the tongue, and 9 inches on the blade, and apply four times, because, as 3 feet is $\frac{3}{4}$ of four feet, so 9 inches is $\frac{3}{4}$ of 12 inches.

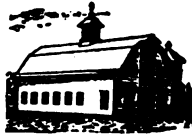

Part IV .

ROOF FRAMING

Rafters—Laying Out a Rafter—Pitches and Fractions—How to Get the Bevels—Roof Pitches Explained—Reversed Pitches—Irregular, Uneven or Unequal Pitches—Projecting Cornices—To Find the Length of Rafters Where the Rises in the Roof are of Different Height—The Pitch of the Tower Roof—Hip Rafters—Length of Hip Rafters—How to Get the Inches and Fractions—Valley Rafters for Gables—Curved Hip Rafters—Common Rafters—To Find the Length and Cut of Rafters—The Measurement Line of Hips and Valleys—An Unequal Pitch—To Find the Length of the Jacks

Rafters.—Fig. 11 shows a plan of a roof, having twenty-six feet of span. The span of a roof is the distance over the wall plates measuring from A to A, as shown in Fig. 11. It is also

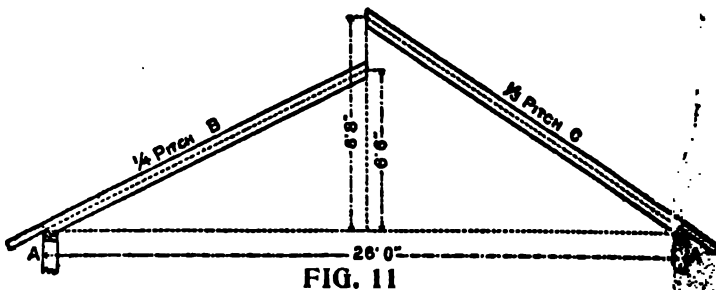

the extent of an arch between its abutments.

There are two rafters shown in position in Fig. 11. The one on the left is at an inclination of quarter pitch, and marked B, and the one on

the right, marked C, has an inclination of one-third pitch. These angles or inclinations rather, are called quarter and third pitch, respectively, because the height from level of wall plates to ridge of roof is one-quarter or one-third the width of building, as the case may be.

In Fig. 12, the rafter B is shown drawn to a larger scale; you will notice that this rafter is for quarter pitch, and for convenience, it is supposed to consist of a piece of stuff 2 inches by 6 inches

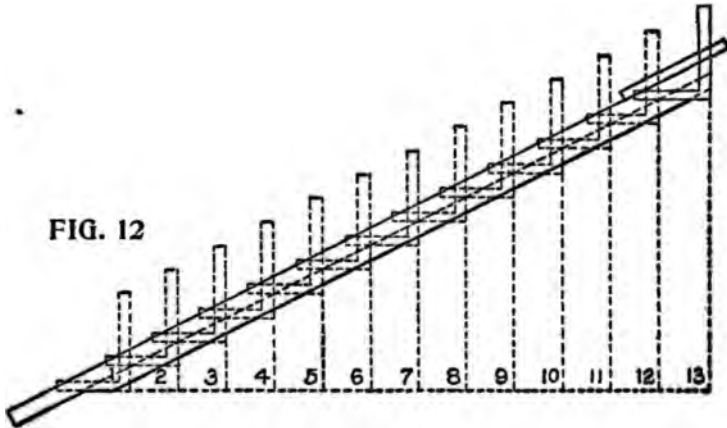

by 17 feet. That portion of the rafter that projects over the wall of the building, and forms the eave, is any width desired. The length of the projecting piece in this case is one foot—it may be more or less to suit the eave, but the line must continue from end to end of the rafter, as shown on the plan, and we will call this line our working line.

Laying out a Rafter.—We are now ready to lay out this rafter, and will proceed as follows:

We adjust the fence on the square the same as for braces, press the fence firmly against the top edge of rafter, and place the figure 12 inches on the left hand side, and the figure 6 inches on the right-hand side, directly over the working line, as shown on the plan. Be very exact about getting the figures on the line, for the quality of the work depends much on this; when you are satisfied that you are right, screw your fence tight to the square. Commence on No. 1 on the left, and mark off on the working line; then slide your square to No. 2, repeating the marking and continue the process until you have measured off thirteen spaces, the same as shown by the dotted lines in the drawing. The last line on the right-hand side will be the plumb cut of the rafter, and the exact length required, which will be found to be 14 feet $6\frac{1}{2}$ inches plus the projection given the eave. It will be noticed that the square has been applied to the timber thirteen times.

The reason for this is, that the building is twenty-six feet wide, the half of which is thirteen feet, the distance that one rafter is expected to reach, so, if the building was thirty feet wide, we should be obliged to apply the square fifteen times instead of thirteen. We may take it for granted, then, that in all cases where this method is employed to obtain the lengths and bevels, or cuts of rafters, we must apply the square half as many times as there are feet in the width of the building being covered. If the building

to be covered is one-third pitch, all to be done is to take 12 inches on one side of the square and 8 inches on the other and operate as for quarter pitch.

We shall frequently meet with roofs much more acute than the ones shown, but it will be easy to see how they can be managed. For instance, where the rafters are at right-angles to each other, apply the square the same as for braces of equal runs, that is to say, keep the 12 mark on the blade, and the 12 mark on the tongue, on the working line. When the roof is more acute, or "steeper" than a right-angle, take a greater figure than twelve on one side of the square, and twelve on the other.

Whenever a drawing of a roof is to be followed, we can soon find out how to employ the square,

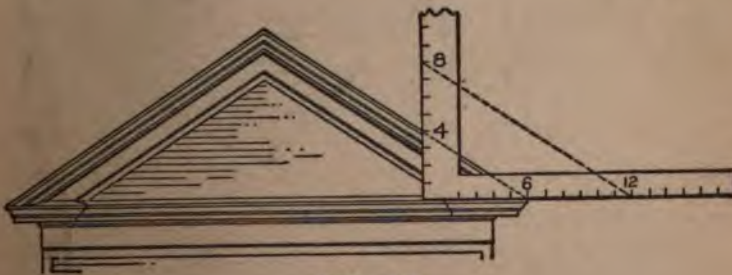

FIG. 13

by laying it on the drawing, as shown in Fig. 13. Of course, something depends on the scale to which the drawing is made. If any of the ordinary fractions of an inch are used, the intelligent workman will have no difficulty in discovering

what figures to make use of to get the "cuts" and lengths desired.

Pitches and Fractions.—Sometimes there may be a fraction of a foot in this division; when such

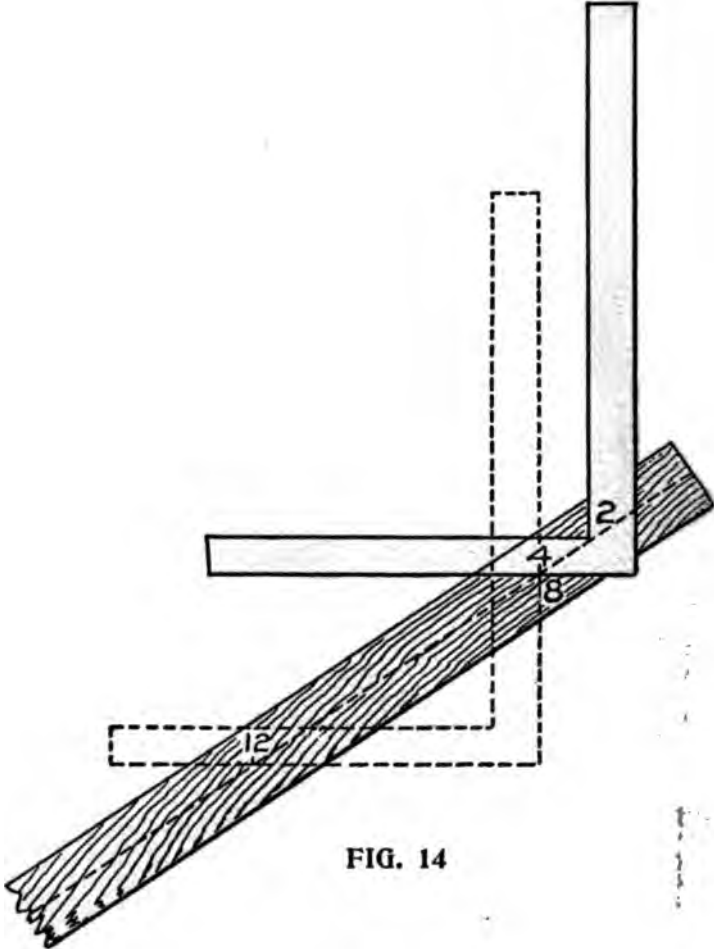

FIG. 14

is the case, it can be dealt with as follows: Suppose there is a fraction of a foot in the span, say $\frac{3}{8}$

inches, the half of which would be 4 inches, or one-third of a foot; then if the roof is quarter pitch, all to be done is to place the square, with the 4-inch mark on the tongue, and the 2-inch mark on the blade, on the center line of the rafter, and the distance between these points is the extra length required, and the line down the blade

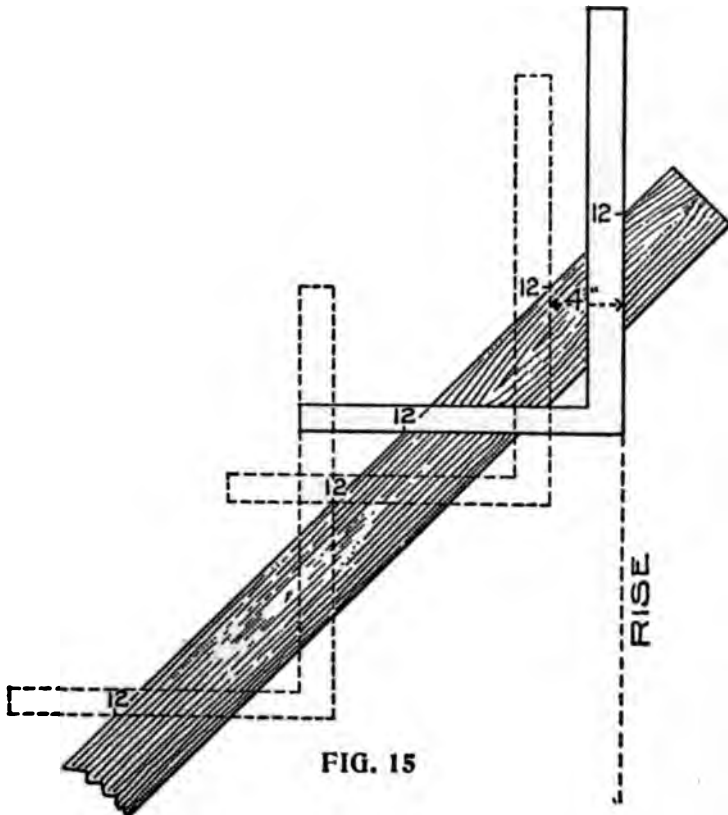

FIG. 15

is the bevel at the point of the rafter. In Fig. 14, is shown an application of this method, or the

correct result may be obtained by measuring at right-angles from the last application of the square as shown in Fig. 15. All other pitches and fractions can be treated in this manner without overtaxing the ingenuity of the workman.

How to Get the Bevels.—Fig. 16 shows how

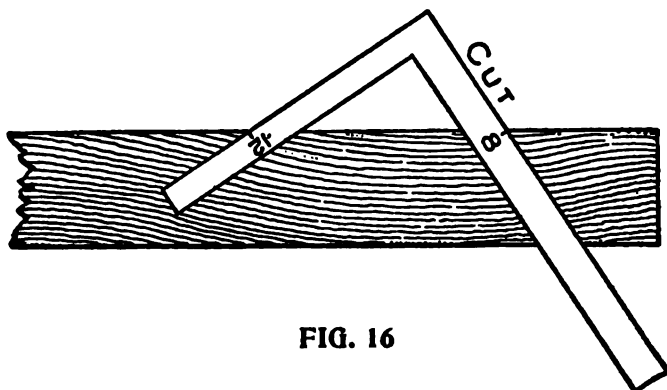

FIG. 16

to get the bevels on the top end of vertical boarding, at the gable ends, suitable for the third pitch at Fig. 11.

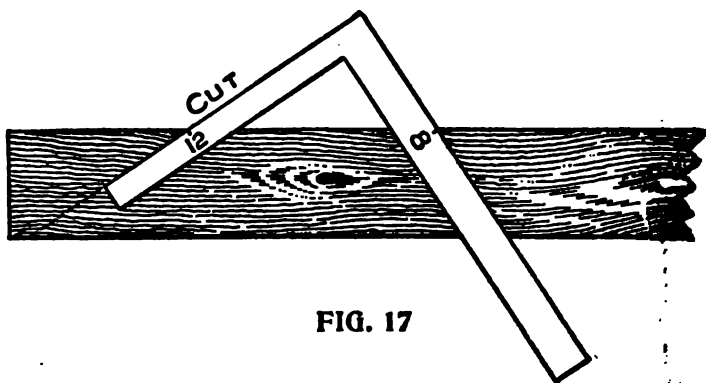

FIG. 17

In Fig. 17 is shown a method for finding the

bevel for horizontal boarding, collar ties, etc. Both of the above are for the one-third pitch.

Roof Pitches Explained.—Inasmuch as roof pitches are not as well understood as they should

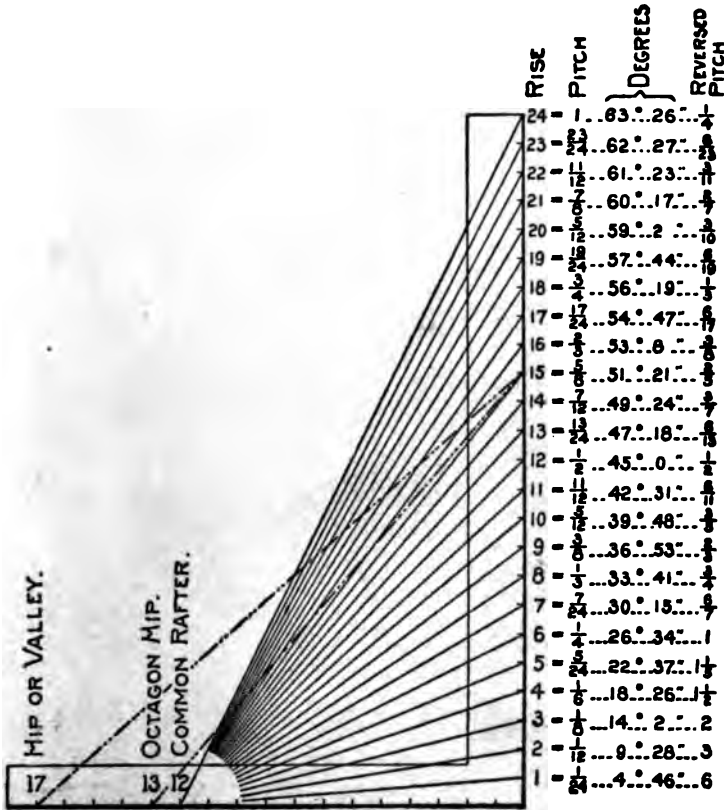

FIG. 18

be, we have thought best at this point to quote from an article, by A. W. Woods, recently published in a trade paper, which will help the student to more fully grasp the subject. In discussing

“pitch” he says: The word “pitch” has reference to the rise given the common rafter in proportion to the span. Therefore by letting 12 on the tongue represent the run of the common rafter the figures on the blade will then represent the rise in proportion to its length (the blade), as 6 being one-fourth of 24 represents the quarter-pitch, 8 represents the one-third pitch, 12 the one-half pitch, etc. See illustration. Fig. 18. For full illustration of roof pitches see Fig. 49A.

For the corresponding hip or valley for the octagon or square cornered building substitute 13 and 17 on the tongue, respectively. However, neither is absolutely correct, but near enough for practical purposes.

The lengths taken diagonally from 12, 13, and 17 on tongue to the figures designating the rise on the blade represent the lengths of the above rafters for a one-foot run. The diagonal lines in the illustration from those figures to 15 on the blade represent five-eighths pitch. Only three of the lengths out of seventy-two are without fractions and they are for the common rafters, as follows: 12 to 5=13 inches, 12 to 9=15 inches and 12 to 16=20 inches. It is on the latter that the rule 6, 8, and 10, so generally used for squaring frame work, is founded. Of course, any of the other angles could be used for this purpose, but the above being without fractions are easy numbers to remember.

The length of the common rafter doubles its run or has a length equal its span when it

has a rise of 60 degrees, which taken on the square is 20.784 inches rise to the foot. The same is true of the octagon hip when it has a rise of a fraction less than 23 inches, and that for the common hip at nearly $29\frac{1}{2}$ inches rise to the foot.

Reversed Pitches.—In the illustration the reversed pitches are also given, that is by letting the blade represent the run and the tongue the rise. The length of the diagonal lines in that case becomes the length of the rafter for a one-foot rise to the inches in run taken on the blade.

The reader will notice that several of these pitches are transposed and are found in the first column, as follows: The 1 pitch is the same as the $\frac{1}{4}$ pitch when reversed. The $\frac{3}{4}$ same as $\frac{1}{3}$; the $\frac{2}{3}$ same as $\frac{3}{2}$; the $\frac{1}{2}$ remains the same or unchanged. The low pitches in the first column become very steep when reversed; thus, the $\frac{1}{12}$ pitch becomes 6 pitches or a rise of 12 feet to a one-foot run. The $\frac{1}{12}$ pitch is equal to a rise of 6 feet to a 1-foot run, etc.

For the corresponding lengths of the hip or valley for the reversed pitches add one-twelfth and five-twelfths to the run of the common rafter for the octagon and right-angled corner respectively. In our illustration we also give the degree of pitch for common rafter. To find the same for reversed pitches, it is only necessary to subtract the degrees here given from 90 degrees.

In the following Mr. Woods gives explanations and diagrams for finding the lengths of rafters where the rises in the roof are of different heights.

Irregular, Uneven, or Unequal Pitches, are simply different pitches in the same roof. When they are the same on all sides and the building is square, the hips or valleys run in from the corners at an angle of 45 degrees, regardless of the rise of the roof; but should one side be steeper than the adjoining side, or the gables be of different pitch from the main roof, then the hips or valleys depart from the 45-degree angle.

Fig. 19 shows a roof plan with the one-third

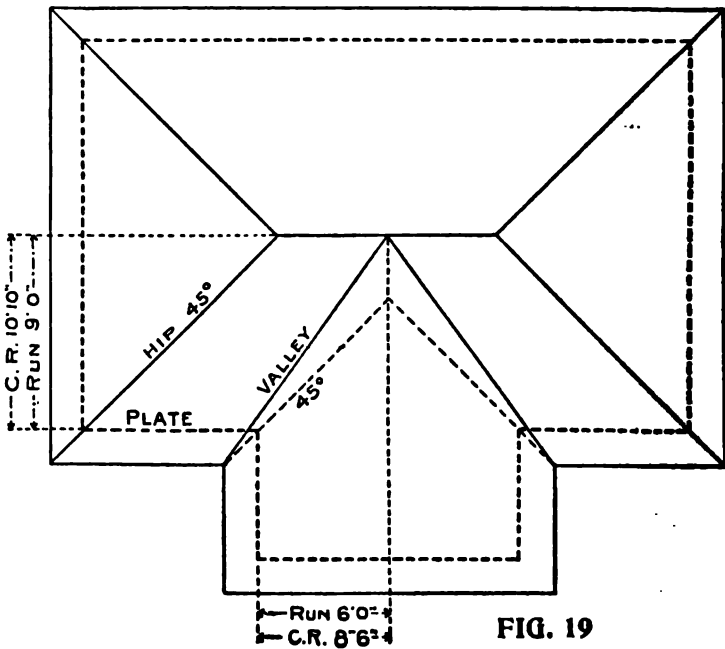

pitch on the main part, with a half-pitch gable. The seat and down cuts of the jack and common

rafters remain the same as in the even pitch roof, except the top cut of the jack.

We will not take up space to explain this cut at length, but will give that obtained by the

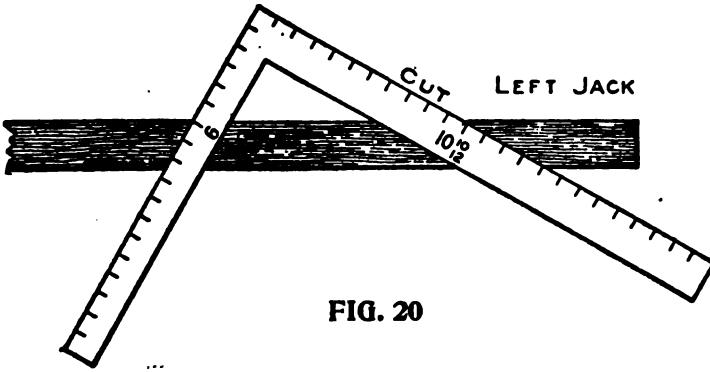

FIG. 20

square as follows: Take to scale the length of the left common rafter on the blade, and the

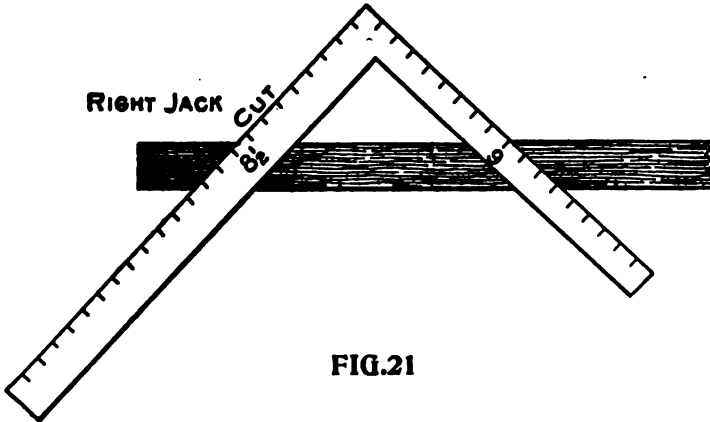

FIG. 21

run of the right common rafter on the tongue. Blade gives the cut of the left jack. Vice versa

Thus, if the cornice be 18 inches wide, the rise of the half pitch is 18 inches, and that of the one-third pitch is 12 inches, a difference of six inches. Therefore the proper height of the plate above that of the lower pitch is six inches.

To Find the Length of Rafters Where the Rises in the Roof are of Different Height; for example, we will suppose the main gable, Fig. 22, to be 24 feet wide with a 14-foot rise, and the side gable to be 16 feet wide with a 10-foot 8-inch rise. In a case of this kind it is better to let one of the valleys extend on up to the ridge board of the main gable and let the other valley rest against it (the long valley). But how to locate them on the square is the main question. 1st. Place the squares as shown. On square No. 1 lay off the run and rise of the wide gables, and the same for the narrow gable on square No. 2.

2d. By connecting the run and the rise, as shown by the diagonal line on each of the squares will be the length of the common rafter.

3d. Square out from the tongue as shown, till they intersect at A, which will be the runs of the gables or of the common rafters.

4th. Set compasses at B, and open to equal the rise of the narrow gable and swing to the blade of No. 1, and square in to the common rafter, thence run an imaginary line parallel to the blade, and where it intersects the tongue establishes the point where the ridge of the narrow gable or dies intersects on main roof and which point we will call C.

5th. A line drawn from A to C represents the run of the short valley and by extending the line on to the blade of No. 1 establishes point D, from which to B, represents the run of the long valley, and these lengths taken on the tongues as shown, and connected with their respective rises, will be their lengths.

6th. The lengths of the jacks are found as shown from E to F, which we trust is clear enough without further explanation.

The cuts and bevels are all contained in this diagram.

The Pitch of the Tower Roof may be obtained along with all the bevel lines by the proper use of the steel square, as shown in Fig. 23, which illustrates some unusual pitches. It is evident that if the run of 1 foot is 12 inches, the span must be double that or 24 inches; therefore the rise must be that proportion of the

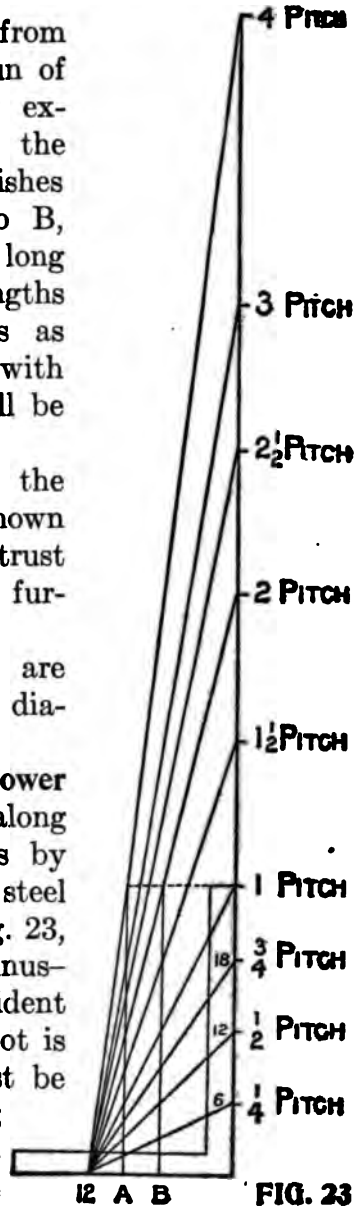
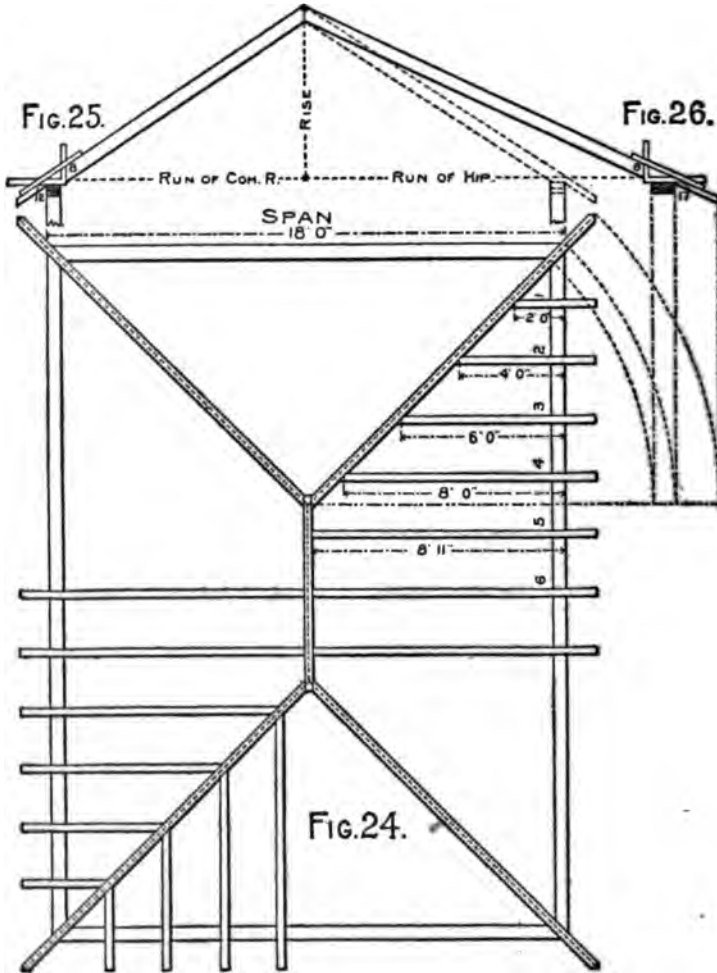

FIG. 23

span. Then the first inch in rise is one-twenty-fourth, the second one-twelfth, the third one-eighth, etc. The twenty-fourth inch rise being equal the span, it is therefore one pitch. As the rise continues above this point, it is simply a repetition of the above with a 1 prefixed, thus: The twenty-fifth inch rise being one and one-twenty-fourth pitch, etc.; but we are now beyond the limits of the full scale as applied to the square, so we must reduce the scale. By letting the vertical line B represent the blade we will have reduced the scale one-half. The pitches would center at 6 on the tongue instead of 12, as in the full scale. We must now use the half inches above 12 on the blade for each rise of one inch till we reach the twenty-fourth inch, which will be equal to two pitches or 48-inch rise to the foot. For steeper pitches it is necessary to again change the scale. If we let the blade rest at A the pitches will center at 3 on the tongue (making the scale $\frac{1}{4}$ size), and by letting the $\frac{1}{4}$ inches above 12 on the blade represent the full inches in rise will give the cuts, etc., from the forty-eighth inch rise to the ninety-sixth inch rise to the foot, or 4 pitches.

Hip Rafters.—Fig. 24, represents the plan of a roof as furnished by an architect. Fig. 25 shows the square set to the pitch of the common rafter, while Fig. 26 shows the same for the hip rafter. The squares as set give plumb and level cuts. Fig. 24 is the rafter plan of the house 18 by 24 feet; the rafters are laid off on the level, and

measure nine feet from center of ridge to outside of wall; there should be a rafter pattern with a plumb cut at one end, and a foot cut at the other,



gotten out as previously shown. (Fig. 25, 26). When the rafter foot is marked, place 12 on the

long blade of the square to the wall line, as in Fig. 25, and mark across the rafter at the outside of the short blade, and slide the square up the rafter and place the 12 of the long blade to the mark last made and mark outside the short blade as before, repeat the application until nine feet are measured off, and then the length of the rafter is correct; remember to mark off one-half the thickness of ridge-piece, which is done by measuring at right-angles back from the plumb cut. The rafters are laid off on part of plan to show the appearance of the rafters in a roof of this kind, but for working purposes the rafters 1, 2, 3, 4, 5, and 6, with one hip rafter, are all that are required.

Length of Hip Rafters—How to Get the Inches and Fractions.—Fig. 26A shows how to get the length of a hip rafter for a half pitch roof for a building 17 feet 7 inches wide, making 8 feet 9½ inches in the run. For the 8 feet in the run 17 and 12 are taken eight times on the square. The reason 17 is used is because it is the practical length of the diagonal of a one-foot square, and 12 is used because it represents the half pitch to a one-foot run, as shown in Fig. 26A. Therefore these figures taken on the steel square eight times will give the length for the eight feet in the run, and for the nine and one-half inches proceed in the same way taking the diagonal of nine and one-half inches, which is thirteen and one-half, and a line drawn from 13½ parallel with the one from 17 to 12, and the point of intersection on the blade

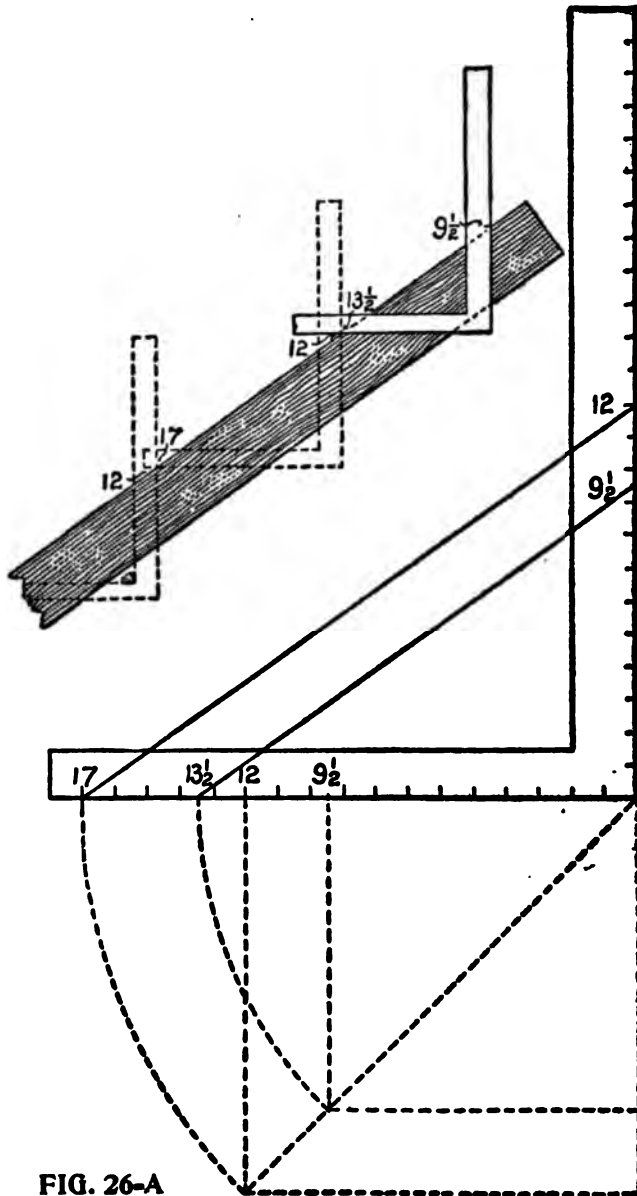

will be the figures to use for the last application of the steel square to obtain the length for the extra nine and one-half inches in the run. In the case of the half pitch, the rise being equal to the run, the figures on the blade are the same as those in the run. This should not be allowed to confuse, as it does not occur in any other pitch.

Valley Rafter for Gable.—To get the length of a valley rafter for a gable of half pitch to fit over another of three-eighths pitch, first lay off the pitches 12 to 12 and 12 to 9, as shown in Fig. 26B. Now assuming that the run for the half pitch is six feet six inches and that for the three-eighths pitch is fourteen feet, we lay off these lengths on the run as shown at A B and A B'. Square up from B and B' to the respective pitches intersecting at C and C'. Then A C will be the length per one inch scale for the common rafter for the half pitch, and A C' will be the same for the three-eighths pitch. Now for the length of the valley, square over from C' to D and drop to E on the run, and this transferred to A E' represents the end, and A B' the side of a plan whose diagonal A F will represent the run for the long valley to catch the ridge of the main gable, and this transferred to F' and erect the rise F' G, and draw the line A G which will be the length of the long valley, and by squaring over from B C intersecting A G at J. Thus A J will be the length for the short valley and its run will be A J. The point at H is at the intersection of the ridge of the half pitch with the main roof. J G represents

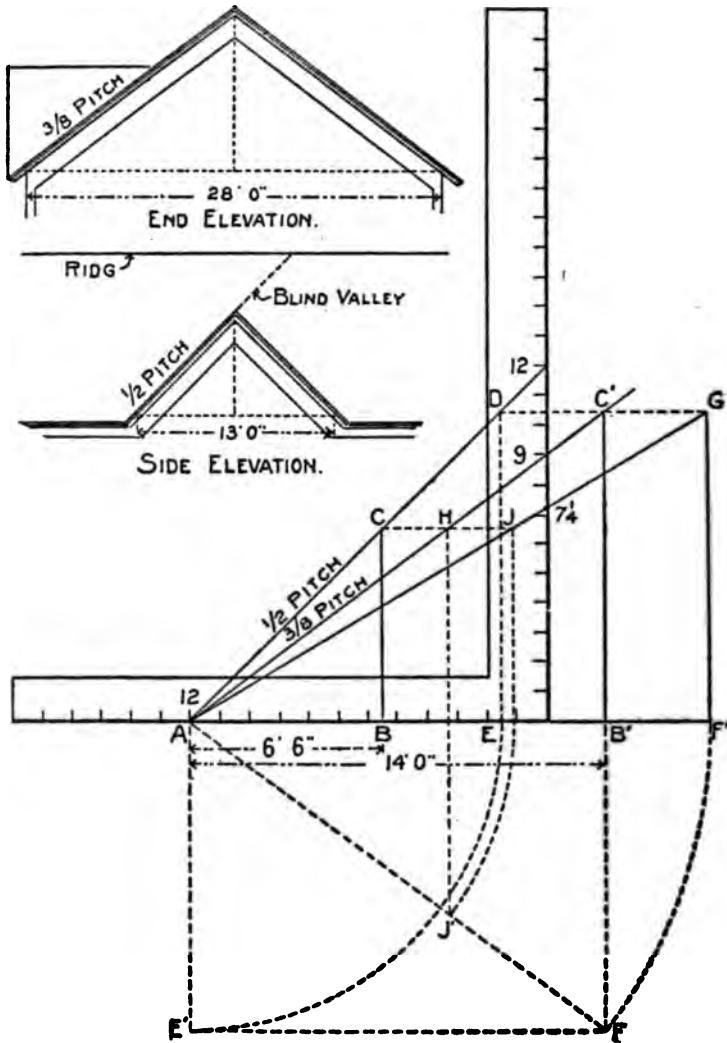

FIG 26 B

that part of the long valley commonly called blind valley. Where the roofs of different pitches

are of the same height it is quite an easy matter to arrive at the length of the valley, as their runs

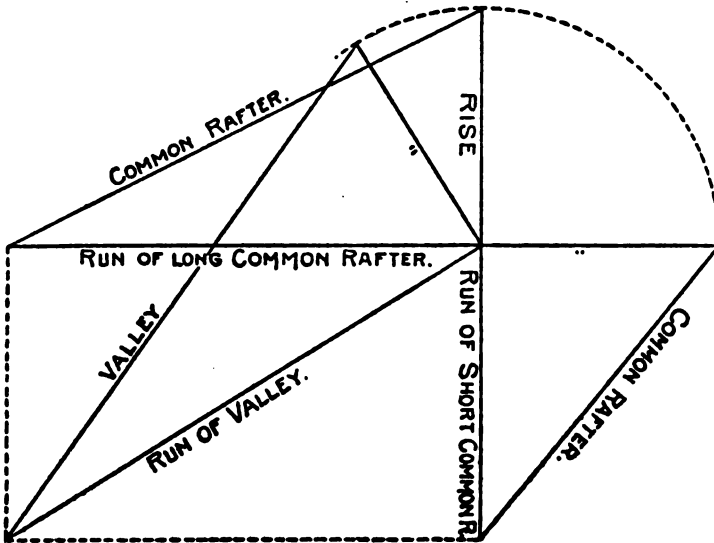

FIG. 26 C

form the sides of the plan as shown in Fig. 26C, which needs no further explanation.

Curved Hip Rafters.—Fig. 27 shows how a curved hip-rafter may be obtained. The rafter shown in this instance is ogee in shape, but it makes no difference what shape the common rafter may be, the proper shape and length of hip may be obtained by this method. It will be noticed that one side of the example shown is wider than the other; this is to show that the rule will work correctly where the sides are unequal in width, as well as where they are equal.

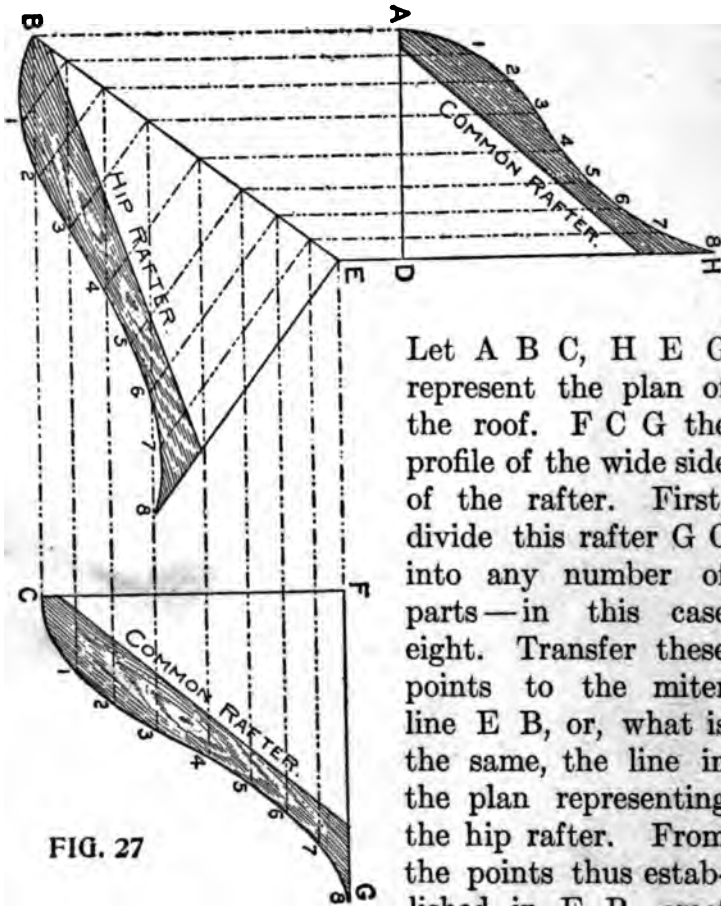

FIG. 27

Let A B C, H E G represent the plan of the roof. F C G the profile of the wide side of the rafter. First, divide this rafter G C into any number of parts—in this case eight. Transfer these points to the miter line E B, or, what is the same, the line in the plan representing the hip rafter. From the points thus established in E B, erect

perpendiculars indefinitely. With the dividers take the distance from the points in the line F C, measuring to the points in the profile G C, and set the same off on corresponding lines, measuring from E B, thus establishing the points 1, 2, 3, etc.; then a line traced through these points will be the required hip rafter.

Common Rafters.—For the common rafter on the narrow side, continue the lines from E B parallel with the lines of the plan H E and A B. Draw A D at right angles to these lines. With the dividers as before, measuring from F C to the points in G C, set off corresponding distances from A D, thus establishing the points shown between A and H. A line traced through the points thus obtained will be the line of the rafter on the narrow side. This is supposed to be the return roof of a veranda, but is only shown as an example, for it is not customary to build verandas nowadays with an ogee roof, but with a rafter having a depression or cove in it. For accuracy it would be as well to make nearly twice the number of divisions shown from 1 to 8, as are there represented.

In speaking further of roof-framing and particularly of framing of hip and valley roofs, Mr. Woods says: Much has been said and can be said on the subject, but it is my aim to say as little and do as much as I can to make the subject clear. Every carpenter knows that the run and rise of the rafter taken on the square will give the seat and plumb cuts, but inasmuch as buildings are not all of the same width, it requires a different set of figures for each run, and as it requires an extra calculation to find the run of the hip or valley, it is better to use the full scale for a one-foot run of the common rafter, which answers for any run.

To Find the Length and Cut of Rafters.—Referring to Fig. 28, we show a square bounded by

28

THE SQUARE

FIG. 28. THE SIDES OF WHICH ARE 12 INCHES.
 FIG. 29. THE SIDES OF WHICH ARE 12 INCHES.

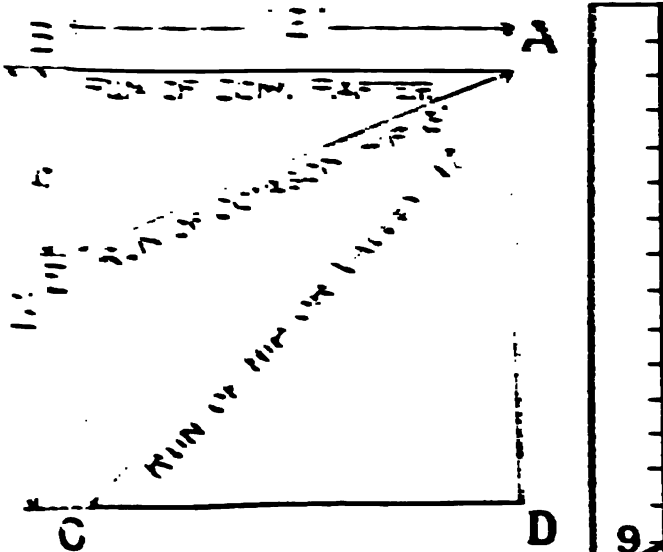

FIG. 28

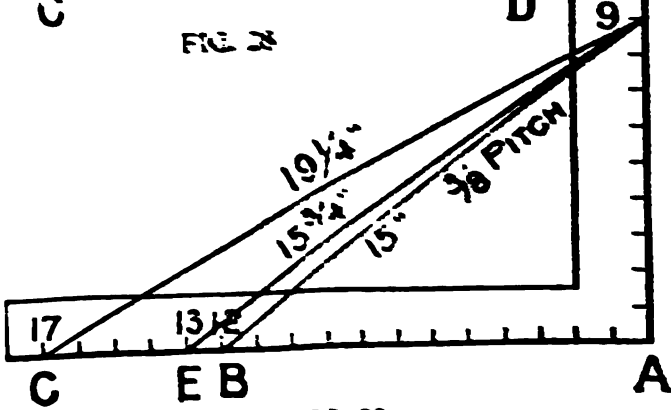

FIG. 29

from B. B-A represents the run of the common rafter. E-A represents the run of the octagon hip or valley, and C-A the same for the common

hip or valley, their lengths being 12, 13, and 17 respectively. Now since 12, 13, and 17 are fixed

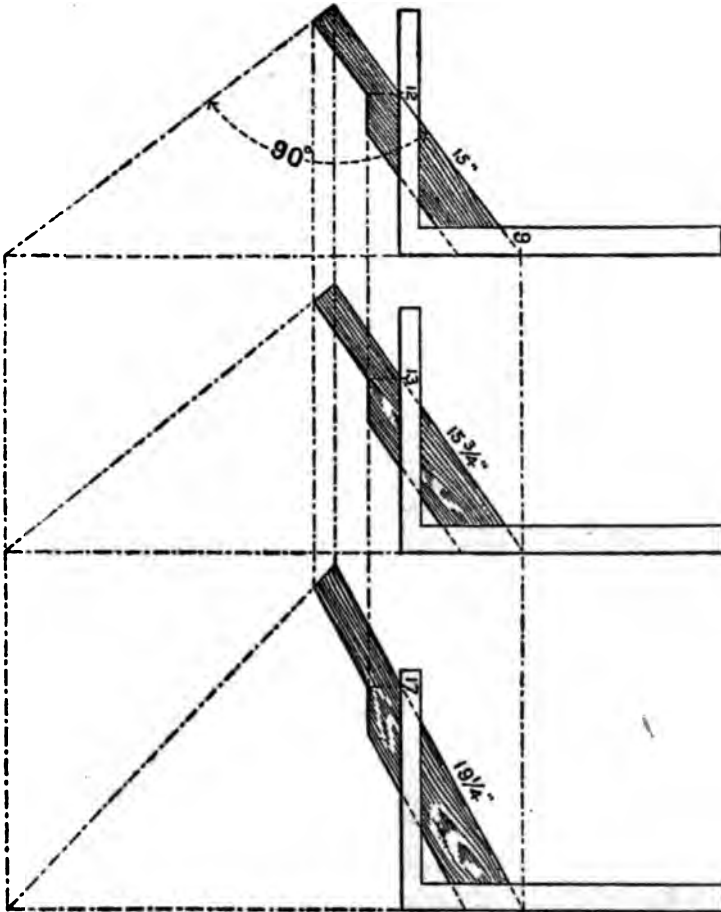

FIG. 30

numbers, we take them on the tongue of the square, as shown in Fig. 29. Now suppose we want to find the lengths and cuts of the rafters

for the $\frac{3}{4}$ pitch. We take 9 on the blade. Why? Because the run being 12 inches, the span must be two times 12, which equals 24, and since the pitch is reckoned by the span, we find that $\frac{3}{4}$ of 24 is 9, which represents the rise to the foot run.

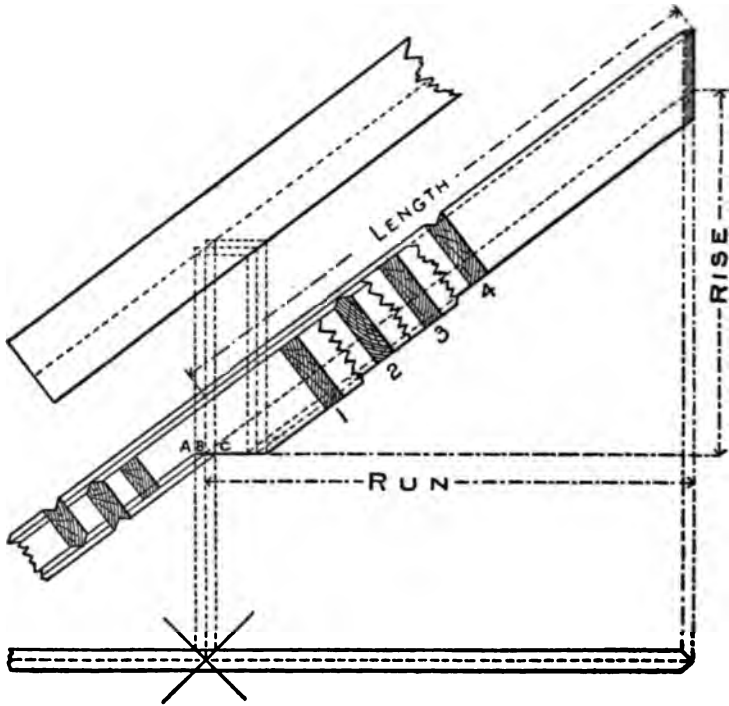

FIG. 31

Then 12 and 9 give the seat and plumb cuts for the common rafter, 13 and 9 for the octagon hip or valley, and 17 and 9 give the same for the common hip or valley. In Fig. 30 we show each separately.

The Measurement Line of Hips and Valleys is a line along the center of its back, and just where to place the square on the side of the rafter so as to make the cuts and length come right at that point is a question that taxes the skill of most carpenters, especially so when the rafters are so backed. In Fig. 31, we have tried to make the above points clear.

First, we show the plan of the rafter. The cross lines on same represent an external corner for the hip and valley respectively. Above the plan is shown the elevation. The sections 1, 2, 3, 4, represent the position of the rafters under the following conditions: No. 1 hip when not backed, No. 2 hip when backed, No. 3 valley when not backed, No. 4 valley when backed. By tracing the bottom line of each section down to the line C-A which is parallel to the seat cut and is regulated by the height given the upper edge of the common rafter above the corner of the plate as at A-B, will show how deep the notching should be for each rafter. No. 1 cuts into the right hand vertical line from the plan, which would make it stand at the right height above the plate, but in order to make the seat cut clear the corner of plate, it is necessary to cut into the center line above the plan. No. 2 cuts into the same points as No. 1, but owing to its being backed, the seat cut drops accordingly. No. 3 cuts into the center vertical line, and in order to clear the edges of the plate must cut out at the sides to the left vertical line. No. 4 cuts in the same as

the latter, but as much lower than No. 3 as No. 2 is below No. 1.

The outer vertical lines from the plan represent the width of the rafter. Therefore if the rafter be two inches thick, would be one inch apart, and this amount set off along the seat line (or a line parallel with it) will give the gauge point on the side of the rafter. To make this clearer refer to Fig. 30; 17 and 9 gives the cuts. Now leaving the square rest as it is, measure back from 17 one-half the thickness of the rafter, and this will be the gauge line point from which to remove the wood back to the center line of hip, and the measurement from the edge of the rafter taken vertically down to the gauge point set off on the plumb cut regulates how far apart the parallel lines of the seat cuts will be under the above conditions. This rule applies to any roof so long as the pitches are regular.

Proceed in like manner for the octagon hip, the variation, however, is five-twelfths or practically one-half of the above results for the square cornered building.

In Fig. 32 is shown the plan of a hip and common rafter in place, also an elevation of same with the hip swung parallel to the common rafter, A C and A B being their respective lengths. This figure also illustrates the relative pitch of one to the other but when set in their respective places on the building are of the same plane.

Fig. 33 illustrates side cut of the jack, 12 on

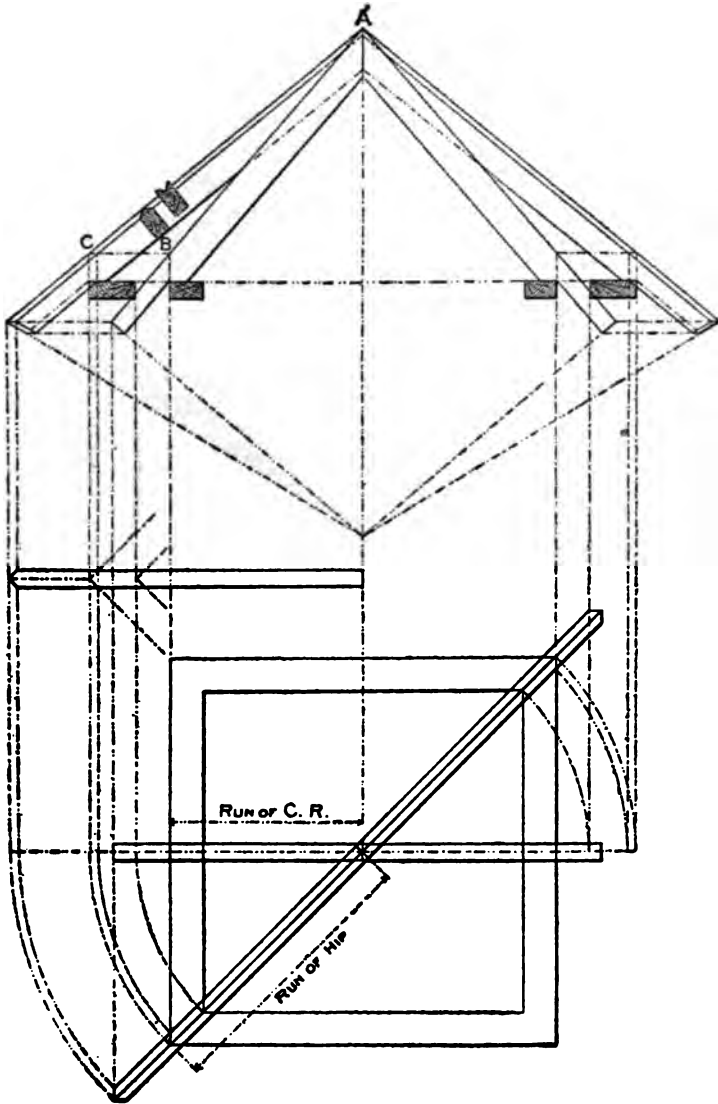

FIG. 32

the tongue, and 15 (length of the common rafter) on the blade.

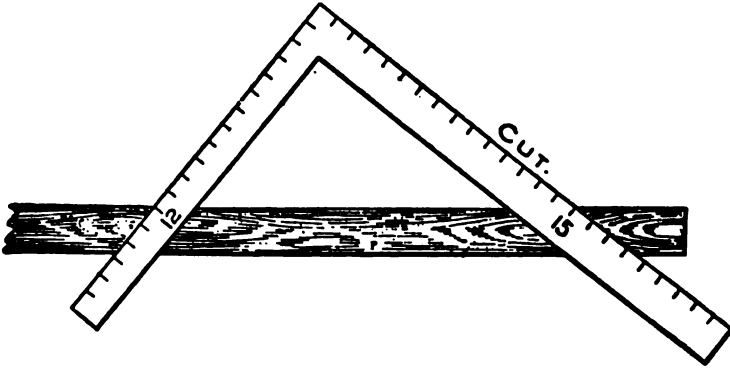

FIG. 33

Fig. 34 illustrates side cut of the octagon jack, 5 on the tongue and 15 on the blade.

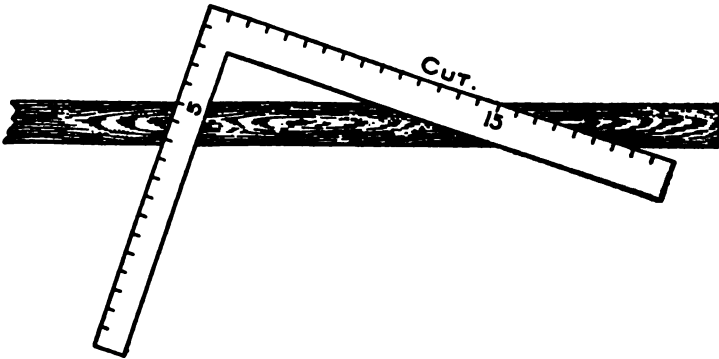

FIG. 34

Fig. 35 illustrates the side cut of the hip or valley, 17 on tongue, $19\frac{1}{4}$ (length of the hip) on the blade. The blade giving the cut in each case.

The latter, however, is for the unbacked rafter. If it has been previously backed, then apply the square with the above figures on the lower edge at bottom of the plumb cut, or apply the

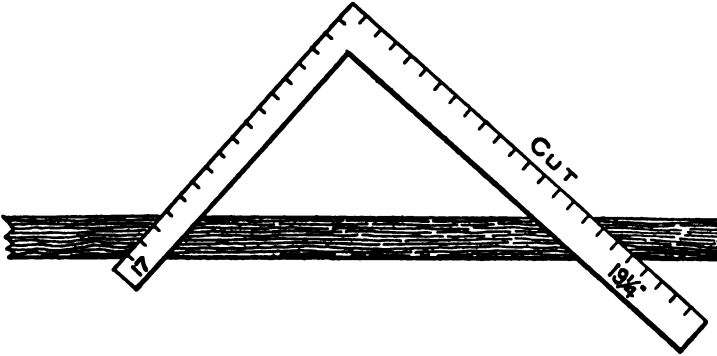

FIG. 35

square as for the jack, Fig. 33, to the backing line, which will give the same result as 17 and $19\frac{1}{4}$.

It is quite clear that when a workman cuts a common rafter he is also cutting a timber that would answer for a hip for a building of less span having the same rise, only taking some adjustment of the top bevel to fit against the ridge. This is quite plain, and if we refer to Fig. 36 we find that the common rafter for a 1-foot run becomes a hip for an $8\frac{1}{2}$ inch run, and that a hip for a 1-foot run of the building becomes a common rafter for a 17-inch run. Therefore, the rule that applies to the common rafter also applies to the hip rafter, i. e., the run and rise taken on the square will give the seat and plumb cuts. The run and length of the rafter taken

on the square will give the side cuts, or taking the scale for a 1-foot run, Fig. 36, it is 12 on the tongue and the rise on the blade for the common rafter, and 17 on the tongue and rise on the blade

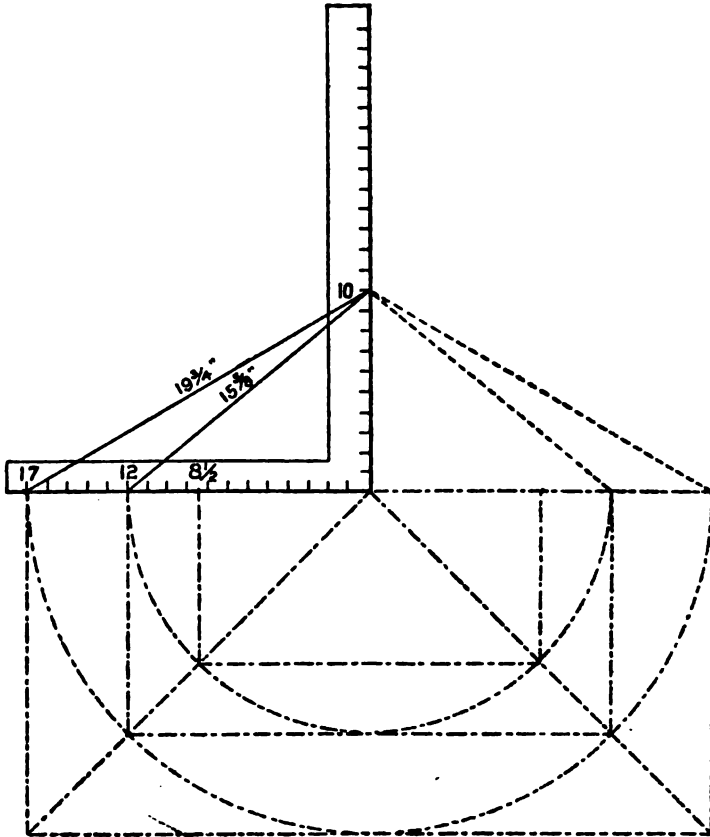

FIG. 36

for the hip. The tongue giving the seat cut and the blade the plumb cut. For the side cuts we take 12 on the tongue and 15 and five-eighths

inches on the blade, and the blade will give the side cut of the jack. Take 17 on the tongue and the length of the hip, $19\frac{1}{4}$ inches on the blade, and the blade will give the side cut of the hip. It would also be the side cut of the corresponding jack if it be a common rafter. Seventeen is used for a foot run of the hip rafter because the diagonal of a 12-inch square is practically 17 inches.

If we were to use 12 on the tongue for a foot run of the hip the rise to the foot would necessarily be less than 10 inches. In Fig. 37 we show what the difference is in the rise to the foot.

From 12 to 12 is the length of the run of the hip, and this, taken on a continued line of the run of the common rafter, and an equal rise of the common rafter, set off as at A, and a line from this to 12 on the tongue passes at $7\frac{1}{2}$ and one-

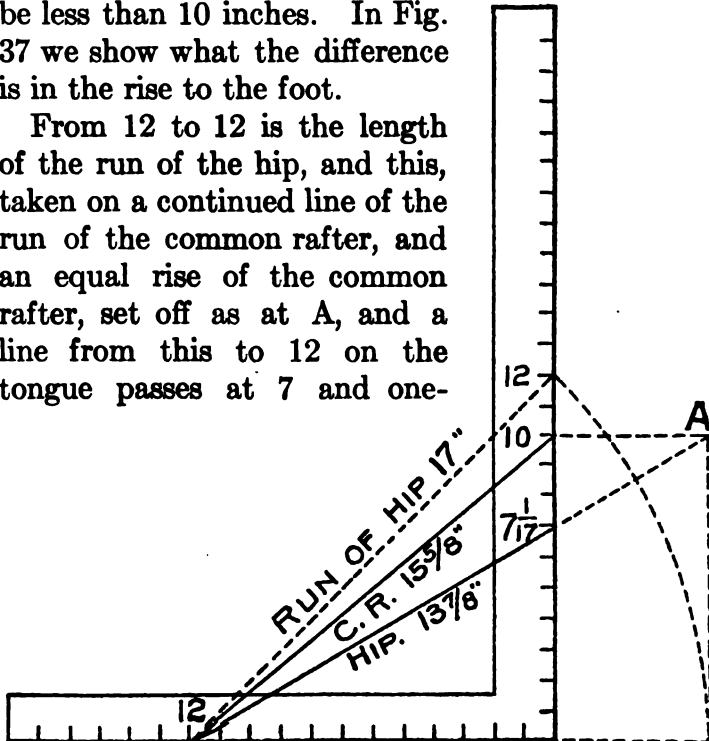

FIG. 37

seventeenth inches on the blade, because the common rafter having a rise of 10 inches to one foot, for one inch it would have ten-twelfths of an inch, while the hip would only have ten-seventeenths of an inch to one inch and for 12 inches it would be 12 times ten-seventeenths, equals 120 seventeenths, or 7 and one-seventeenth inches. Therefore the figures given in the second part of illustration would give the same cuts as those in the first, but the latter necessitates a calculation that ends in fractions—fractions not given on the square—and for that reason 17 is generally used for a foot run for the hips and valleys.

An Unequal Pitch.—In the matter of roofing over unequal pitches when there is no ridge and when all hips meet, the building being longer than it is wide, the backing of hips and their lengths and bevels would be a very easy matter if a drawing of the whole thing were made, but, to obtain these by the use of the square alone, is somewhat more difficult. Let us assume the building to be 18 feet wide and 28 feet long, and having a rise of 9 feet, then, by referring to Fig. 38, we show to one-inch scale the length, run, rise, seat, and plumb cuts for the hip and common rafters as follows: The run of the long way of the building is 14, and 9 for the narrow way, which we take on the blade and tongue respectively, as shown on square No. 1, and to this apply square No. 2, as shown. A D equals the run of the hip. A E equals the rise and E D

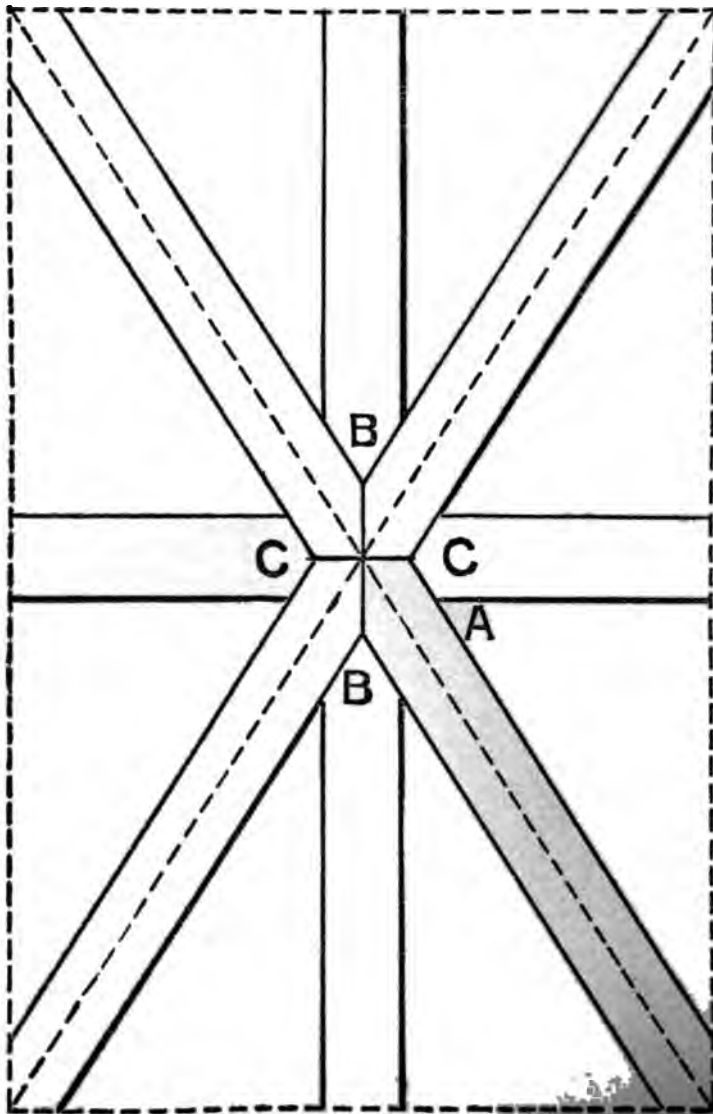

FIG. 39

sary that the common rafters must cut back so as to fit in the angle formed by the hips. The proper deduction for this is shown in Fig. 40 by

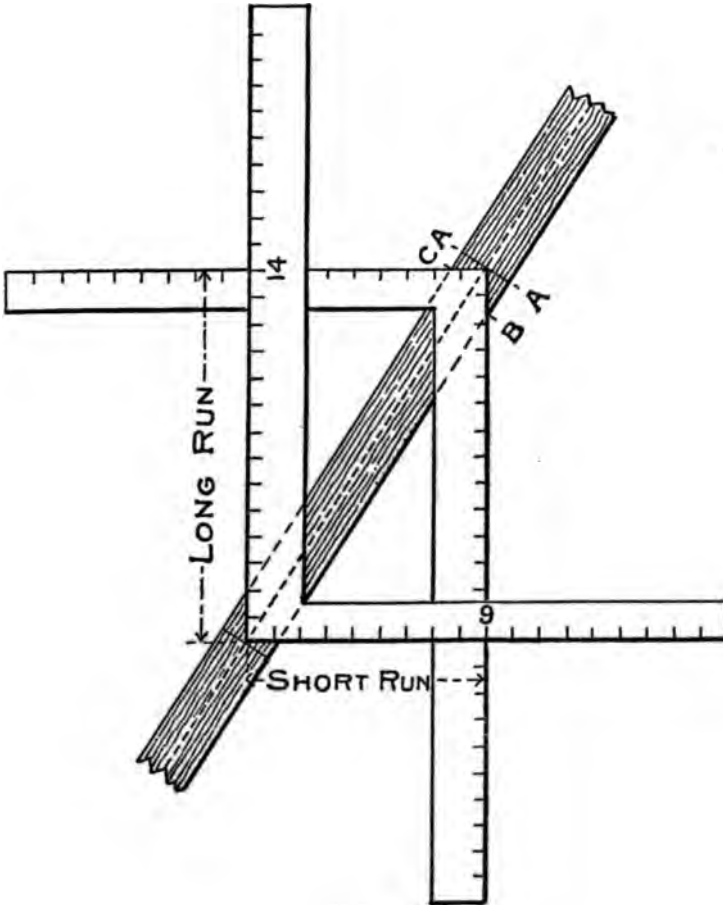

FIG. 40

placing two squares on the back of the rafter, with the heel or corner of the squares resting on the center line. The distance from the corner

of the square to B measured square back (at right angles) from the plumb bevel, as shown in Fig. 38, will locate the point of the long common rafter at B in Fig. 39. Proceed in like manner for the short common rafter, taking the distance from the corner to C, and for the side cuts, take 14 on the tongue and the length of the short common rafter C E on the blade—the blade will give the cut at A C in Fig. 39. The reader will observe that this angle is the same as that for the side of the jack. Proceed in like manner for the long common rafter side, using 9 on the tongue and B E on the blade. These same figures will give the side cuts of the hip, provided hip has been previously backed. Taking the last for example, the reader will observe that 9 on the tongue and B E on the blade, the square would lay on the plane of the backing and the blade giving the cut along the line BB in Fig. 39, or these cuts may be found by measuring square back from a plumb bevel at points A and A, Fig. 40, the distance A C and A B, which will give the proper plumb cut at the sides and intersecting the line A A at the center. These same distances, A C and A B, but transferred to opposite sides, set off on the seat cut or a parallel with it, will give the gauge points on the side of the hip for the backing.

To Find the Length of the Jacks.—The lengths of the jacks may be found by dividing the length of the common rafter by the number of the spacings for the jacks; the quotient will be the common difference.

Part V

HIP ROOF FRAMING

A Formula in Figures—Side Cut of the Hip—Beveling of Hip Rafter—To Cut Bed Moulds—The Principles to be Determined in a Hip Roof—To Find the Backing of a Hip Rafter—How to Find the Shoulder of Purlins—How to Pierce a Circular Roof With a Saddle Roof—Illustration of Roof Pitches—Reckoning by Degrees—Decimal Equivalents—Framing by Degrees—How to Find the Length of the Rafters to a Given Scale, Also the Bevels That Give the Cuts—Octagonal Roofs—Lengths and Bevels of Hips and Jacks—To Obtain Length of Various Rafters for Any Width of Building—Different Kinds of Jacks Described—Hexagonal Roofs—To Timber Hexagonal Roofs

A Formula in Figures.—We first lay off common rafter, which has been previously explained; but deeming it necessary to give a formula in figures to avoid making a plan, we take one-third pitch. This pitch is one-third the width of building, to point of rafter from wall plate or base. For example, always use 8, which is one-third of 24, on tongues for altitude; 12, one-half the width of 24, on blade for base. This cuts common rafter. Next is the hip-rafter. It must be understood that the diagonal of 12 and 12 is 17 in framing, and the hip is the diagonal of a square added to the rise of roof; therefore we take 8 on tongue and 17 on blade; run the same number of times as common rafter, these figures

the side cut of the rafter. To find the length of the rafter, divide the number of rafters by the number of jacks. Suppose we have five jacks, then the number of common rafters is 12 feet and the length of the rafter would be 17 feet shorter. First cut the rafter 17 feet, then 1 foot, and so on. The length of the side cut is for the run of common rafters and the same is for the common rafters. To find the length of the rafter, take half the width of building in square and length of common rafters in square, make good cut, or the same result may be found by taking the diagonal of the run, which is 12-17, then take 17 on a square, 12-17 in square, make good cut.

Side Cut of the Hip.—In connection with the hip there must be another cut considered, called the side cut of the hip, though the angle

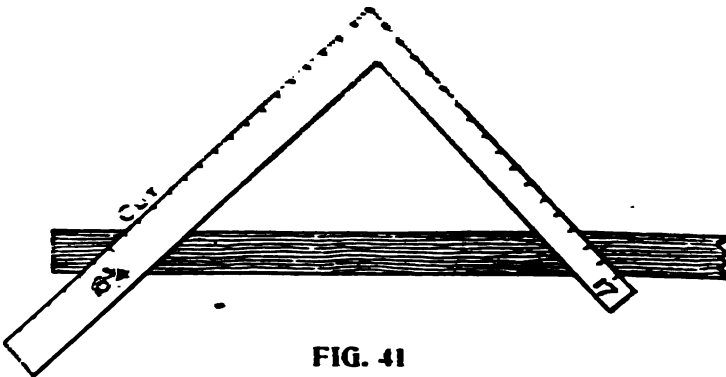

FIG. 41

to obtain this cut is across the top or back of the rafter. Were there no slope to the roof, this angle where it meets the ridge pole would be an

angle of 45 degrees, but when a slope is given this angle becomes more acute. The rule is, take the length of the hip on the blade and its run on the tongue, the blade gives the cut or take 17 on the tongue and $18\frac{1}{2}$ on the blade, blade gives the cut as shown in Fig. 41.

Beveling of Hip Rafter.—The hip-rafter should be beveled so as to be in plane of the common rafter; height of hip on tongue, length of hip on

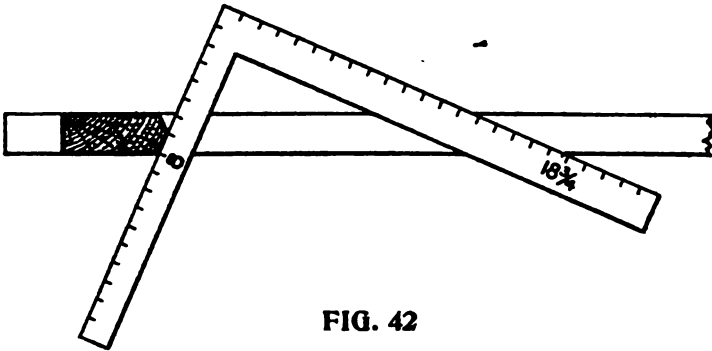

FIG. 42

blade; tongue gives bevel, or we take 8 on tongue, $18\frac{1}{2}$ on blade; tongue gives bevel, as shown in Fig. 42. These figures will cover all cuts in putting on cornice and sheathing.

To Cut Bed Moulds For Gable to fit under cornice; take half the width of the building on tongue, length of common rafter on blade; blade gives cut; machine mouldings will not member, but this gives a solid joint; and to member properly it is necessary to make the mouldings by hand, the diagonal plumb cut differences.

To Cut Planceer, to Run Up Valley: Take

height of the common rafter on tongue, length of rafter on blade; tongue gives the miter cut. The side cut takes the length of common rafter on blade, and run on tongue; tongue gives cut.

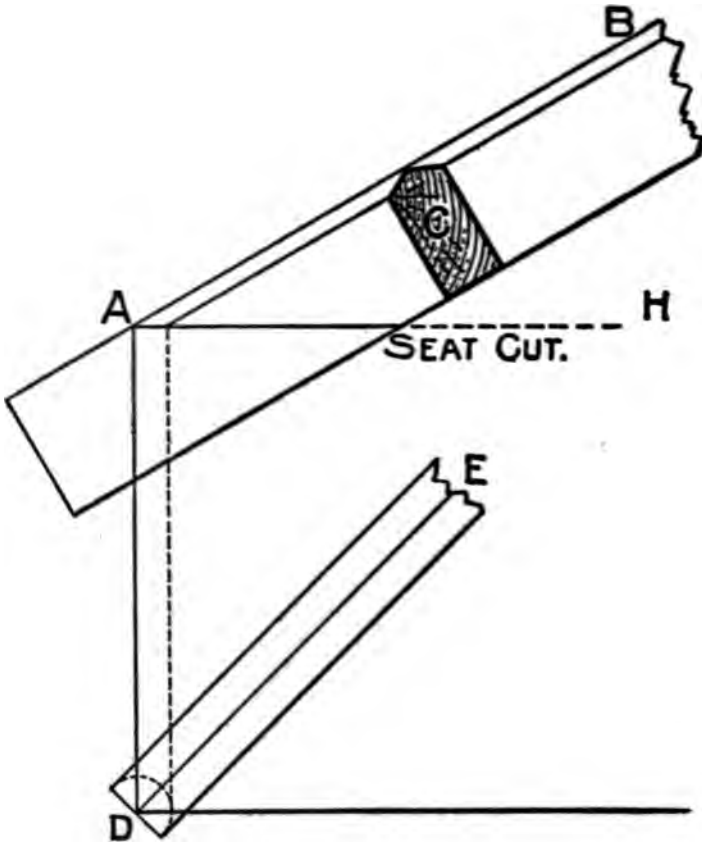

FIG. 43

These figures give the cuts regardless of width of building.

Fig. 43 applies to backing of hips where the

corner is at right angles and the pitches are the same. At the angle D will be seen the intersection of the sides of the angle rafter with the sides of the plan.

With one point of the compasses at D, describe the curve from the line as shown. Tangential to the curve draw the dotted line, cutting AH, then draw a line parallel to A B, the pitch of the hip. The bevel will be found at C, which is a section of the hip-rafter.

The Principles to Be Determined in a Hip Roof are eight, namely:

- 1st. Span or width of building to be roofed.
- 2d. Run of the building, which is $\frac{1}{2}$ the span.
- 3d. The rise given the common rafter.
- 4th. The angle that the common rafter makes with the level of the plate; that is, the pitch of the roof.
- 5th. The length of the common rafter.
- 6th. The angle that the hip-rafter makes with the adjoining sides of the roof.
- 7th. The length of the hip-rafters.
- 8th. The distance from the corner of the building to the center line of the first jack, that is, the common difference.

The 1st, 2d and 3d being given, the others may be found, as will be shown by the following illustration.

To Find the Backing of a Hip Rafter when the plan is right-angled, we proceed as shown in Fig. 44. Let Bb, bC be the common rafters, AD the width of the roof, and aB equal to one-

half the width. Bisect BC in a , and join Aa , $D a$. From a set off ac , ad equal to the height of the roof ab , and join Ad , Dc ; then Ad , Dc are the length of the hip-rafters. To find the backing:

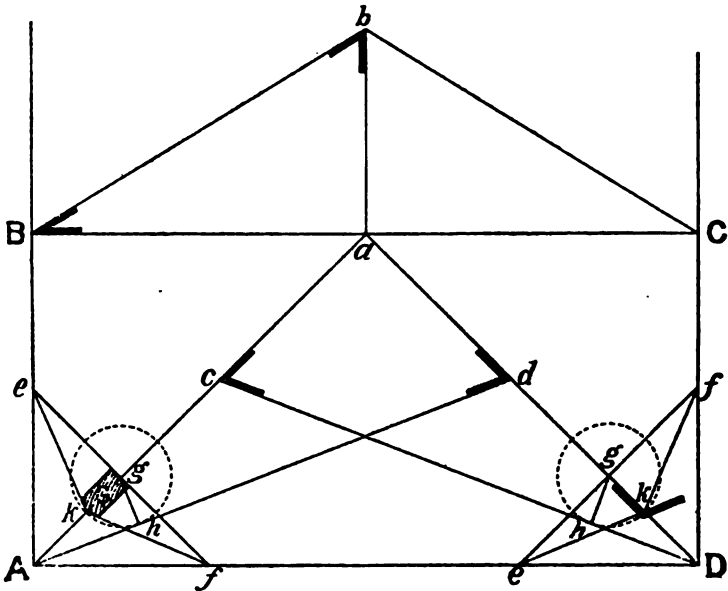

FIG. 44

From any point h in Ad , draw the perpendicular hg , cutting Aa in g ; and through g draw perpendicular to Aa the lines ef , cutting AB , AD in e and f . Make gk equal to gh , and join ke , kf ; the angle ekf is the angle of the backing of the hip-rafter G .

Fig. 45 shows the method of obtaining the backing of the hip where the plan is not right angled.

Bisect AD in a, and from a describe the semi-circle AbD; draw ab parallel to the sides AB, DC, and join Ab, Db, for the seat of the hip-rafters. From b set off on bA, bD the lengths bd, be, equal to the height of the roof bj, and join Ae, Dd, for the lengths of the hip-rafters. To find the backing of the rafter: In Ae, take any point

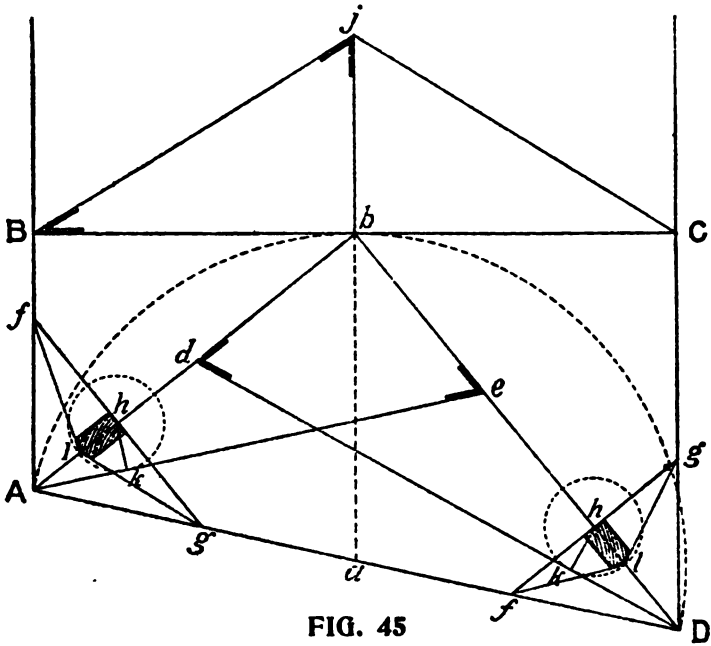

FIG. 45

k, and draw kh perpendicular to Ae. Through h draw fhg perpendicular to Ab, meeting AB, AD, in f and g. Make l equal to hk, and join fl, gl; then flg is the backing of the hip.

How to Find the Shoulder of Purlins.—Fig. 46 shows how to find the shoulder of purlins:

First, where the purlin has one of its faecs in the plane of the roof, as at E. From c as a

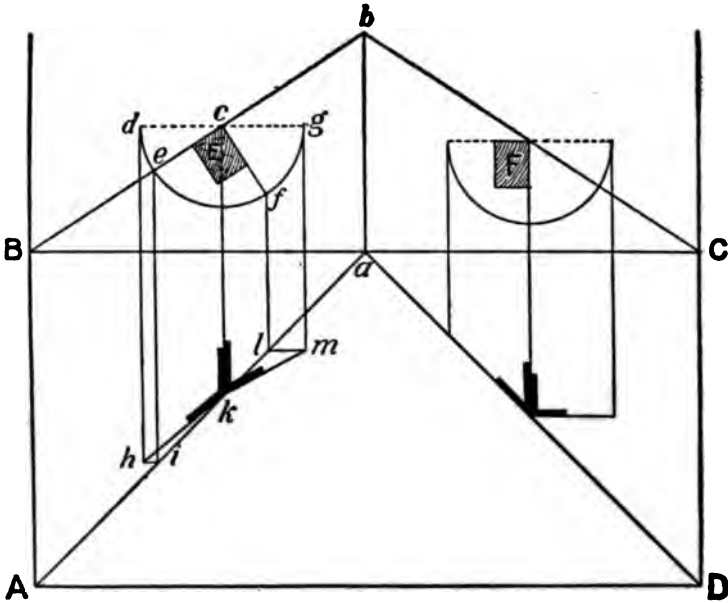

FIG. 46

center, with any radius, describe the arc dg ; and from the opposite extremities of the diameter, draw dh , gm perpendicular to BC . From e and f , where the upper adjacent sides of the purlin produced cut the curve, draw ei , fi parallel to dh , gm ; also draw ck parallel to dh . From l and i draw lm and ih parallel to BC , and join kh , km . Then ckm is the down bevel of the purlin, and ckh is its side bevel.

When the purlin has two of its sides parallel

to the horizon. This simple case is worked out at F. It requires no explanation.

When the sides of the purlin make various angles with the horizon. Fig. 47 shows the ap-

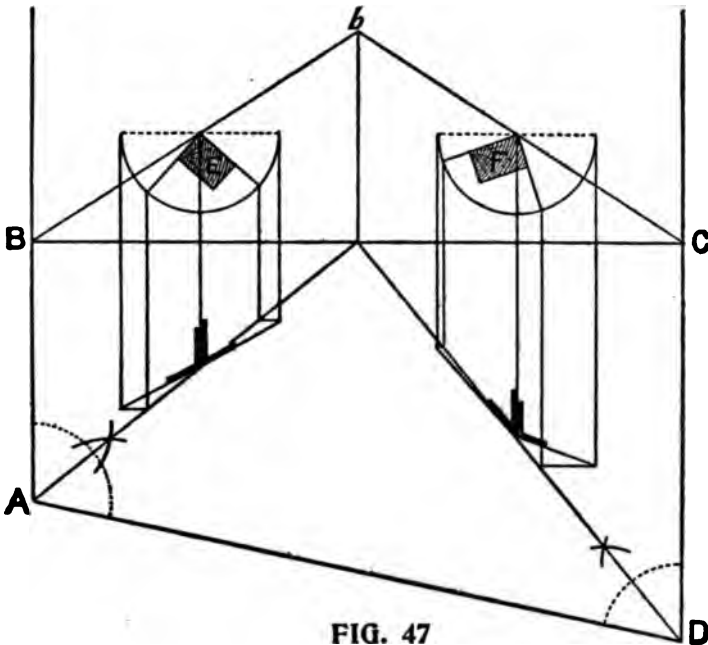

FIG. 47

plication of the method described in Fig. 46 to these cases. See also Fig. 49.

How to Pierce a Circular Roof With a Saddle Roof.—It sometimes happens, particularly in railroad buildings, that the carpenter is called upon to pierce a circular or conical roof with a saddle roof, and to accomplish this economically is often the result of much labor and perplexity if a correct method is not at hand.

triangle KLM, and will give the seat and the length and pitch of the common rafter of the smaller roof B. Divide the lines of the seats in both figures, Dc, KM, into the same number of equal parts; and through the points of division in E, from G as a center, describe the curves ca, 2g, 1f, and through those in B, draw the lines 3f, 4g, Ma, parallel to the sides of the roof, and intersecting the curves in fga. Through these points trace the curves Cfga, Afga, which will give the lines of intersection of the two roofs. Then to find the valley rafters, join Ca, Aa; and on a erect the lines ab, ab perpendicular to Ca and Aa, and make them respectively equal to ML; then Cb, Ab is the length of the valley rafter.

In Fig. 49 is shown another method of finding the bevels of the purlins at the hip or valley.

Let ABC be the eaves of roof, DF and FE the ridges, BF the valley or plan, HE the rise and BE the pitch of roof. Mark the purlin IJK to a large scale—full size if possible—and draw IL, JM, and KN all parallel to EF; make SO equal to JK; draw OP, and draw NP parallel to DF; join MP; and the bevel SMP will apply on the side of purlin. Make RS equal to JI; draw LR; and the bevel SMR will apply on top of purlin.

Illustration of Roof Pitches.—Mr. Woods' illustration in Fig. 49a, contains a whole volume in roof framing. His explanation of the figure is as follows:

In this illustration we show a line for every

inch on the blade; or, in other words, for each inch in rise to one foot of run. Twelve on the

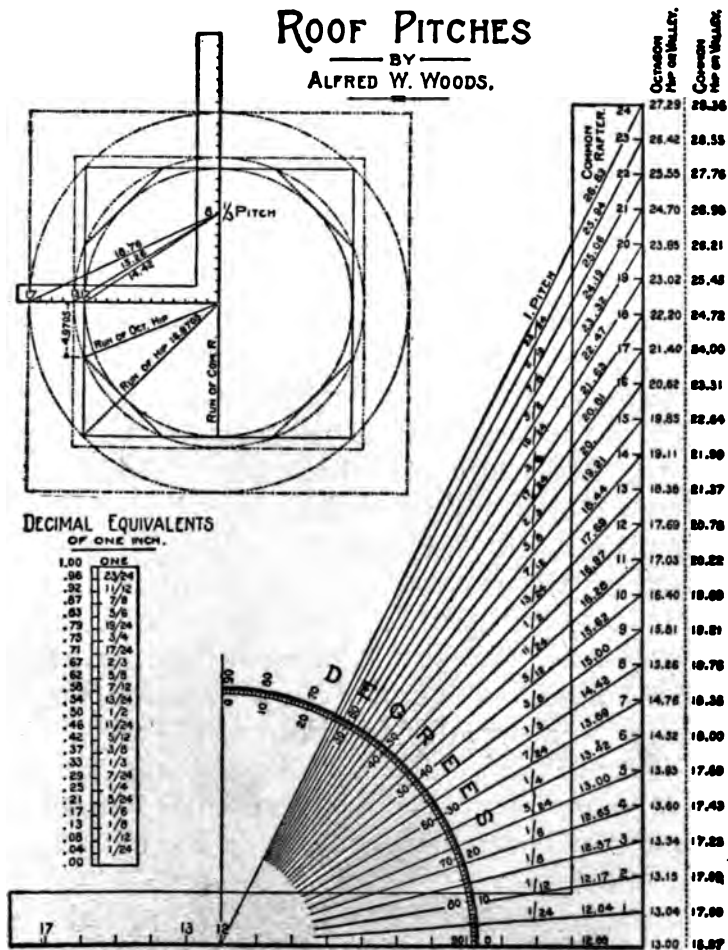

FIG. 49 A

tongue represents unity, because 12 inches is one foot; and since the run is 12 inches, the span

must be double the run, or 24 inches, which is the length of the blade of the square. Then the first inch in rise on the blade must be that proportion to its own length, and produces one-twenty-fourth pitch, the second inch, one-twelfth pitch, the third one-eighth pitch, and continue to the twenty-fourth inch, when it becomes full. The twenty-fifth inch rise would therefore be one and one-twenty-fourth pitch, which is simply a repetition of the above pitches with a one prefixed till it gets up to 48 inches, when it takes on another pitch and represents two pitches, and continues on and on, getting fuller and fuller, but would never stand straight up, because the run remains the same.

The fractional pitch lines for the common rafter are shown for each inch in rise up to the full pitch, and their lengths are expressed in decimal figures to the one-hundredth part of an inch, while to the right of the blade the same is expressed for the corresponding octagon and for the common hip or valley for a square-cornered building, which are reckoned from 13 and 17 on the tongue respectively. However, neither is absolutely correct, though near enough as far as the cuts are concerned. The greater deviation being in the hip for the square-cornered building. It lacks .0295 of being 17 inches and represents the run of the hip to a 12-inch run of the common rafter. Its true length being 16.9705 inches, this is the length from which we have reckoned for the lengths of the hips instead of 17, as is the

usual custom. This may seem a trifling difference, and so it is in a short run and low pitches; but suppose it is for iron construction. To begin with, the shortage of each foot in run with the common rafter is .0295 of an inch; added to this the gain it would have in the pitch, which would be .015 of an inch by the time it got up to the full pitch for the common rafter; and this added to the .0295 to start with would be a difference of .0445 of an inch to the foot in run with the common rafter. Now suppose the run to be 18 feet; $18 \times .0445 = .8+$, or 19-24 of an inch difference; or, if no account was made of the gain in pitch, the .0295 of an inch in the run would amount to over half an inch in the length of the hip alone. This is a common error and while it is not much and probably would never be noticed in wood construction, it is well to know this discrepancy and guard against it when the occasion demands, and for that reason we give the correct amounts. The shortage in the octagon is not so pronounced. Instead of it being in the run, it is the tangent that is lacking the same amount, it being 4.9705 instead of 5 inches. This coming as it does cannot affect the length of the rafter nearly so much as in the above.

We explain this shortage better by referring to that part of the illustration in Fig. 49a showing the plan of a combination square and octagon frame with the heel of the steel square resting at the center. From this it will be seen that the two outer circles catch the corners of the frame

and containing intersecting the tongue at 13 and 17 and opposite the degrees to use on that member of the steel square, but the true length of the run is the hyp. of 21.6715 and that for the tangent of the altitude is 16.755.

Reasoning by Degrees.—Angles are formed by the divisions of the circle, called degrees, of which a complete 360, and these parts are again divided into 60 parts, called minutes, and these parts are again divided into 60 parts, called seconds. From this it will be seen that there are many fractional parts, and it used for the purpose which result in fractions in the lineal measurements of the rise given the roof. Only the 45 degree is without a fraction on the blade of the square when using 12 on the tongue. Besides, there is no way of arriving at the measurement of same without a problem of no small means in trigonometry, or the use of a protractor to arrive at the desired angle from which to take the measurements by scale.

In looking up the subject we fail to find pitch as applied to the roof defined in any of the encyclopedias other than by the degrees given the incline of the roof. Therefore, it is more than probable, to avoid these troublesome fractions, custom has settled on taking a proportion of the span for the rise. Thus, knowing the measurements of two of the factors (run and rise), the third (pitch) is easily arrived at by scale and from their measurements, the various angles for the cuts may be obtained with the steel square with-

out the knowledge of the degrees entering into the problem.

Table of Decimal Equivalents.—In connection with this illustration we also give in Fig. 49a, a table of decimal equivalents to the one-twenty-fourth part of an inch for convenience in finding their value in common fractions.

Framing by Degrees.—The following is copied from an article by Mr. Woods published in a trade paper and will be found useful in this line of work.

In some sections of the country with many framers, the rise is reckoned by the degree instead of a rise in proportion to the span. The rules in the application of the square for the cuts and bevels remaining the same, but in degree framing it requires a trigonometric formula, or a protractor, to determine the rise. In the absence of the protractor one may be temporarily devised as shown in Fig. 50, as follows:

Lay off an angle of 90 degrees, which may be done by marking from the heel of the square along both the blade and tongue. The square, we will say, being in the position of No. 1, and with the angle as center lay off a quarter circle, the radius of which may be any size desired, the larger the more accurate will be the result.

Now reverse the square, as shown by the square No. 2, and with the 12-inch mark on the tongue resting at the heel or angle of square No. 1. A line from 12 to 12 will bisect the quarter circle at an angle of 45 degrees. Now with a pair of spacers divide the arcs thus formed into nine

spaces which will make the divisions five degrees each, and by finding these spaces into five

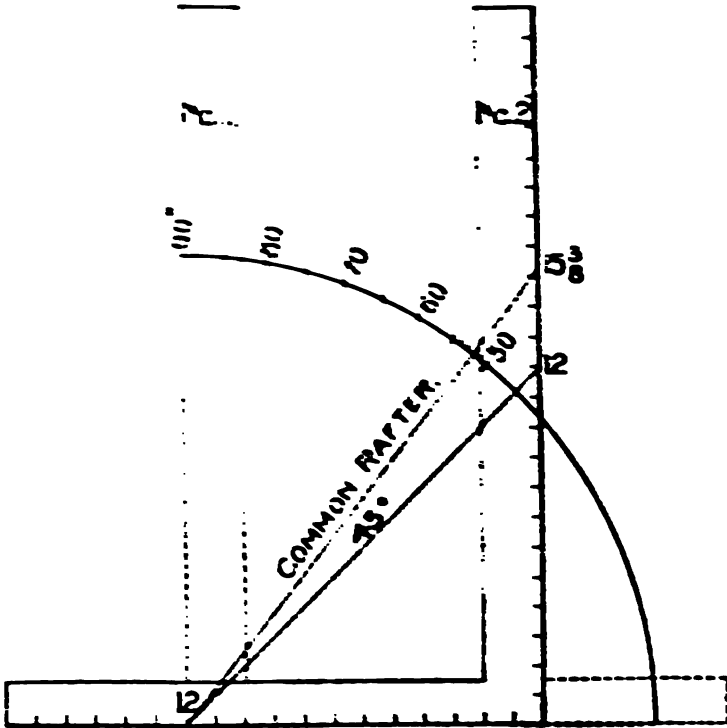

FIG. 50

equal parts will give the division of the degrees. However, it is only necessary to divide that section containing the desired degree. If it be 52 degrees then we divide the space above 50 degrees, as shown, and a line from 12 on the tongue and passing at 52 degrees will intersect the blade at 15½ inches and represent the rise per foot in the run.

By the ~~construction~~ ~~the~~ ~~use~~ ~~of~~ ~~the~~ ~~com-~~
~~pass~~ ~~and~~ ~~the~~ ~~rule~~ ~~is~~ ~~to~~ ~~draw~~ ~~an~~ ~~arc~~
~~with~~ ~~its~~ ~~center~~ ~~at~~ ~~the~~ ~~point~~ ~~B~~ ~~for~~ ~~the~~ ~~radius~~ ~~BC~~
~~the~~ ~~arc~~ ~~will~~ ~~cut~~ ~~the~~ ~~line~~ ~~DE~~ ~~at~~ ~~the~~ ~~point~~ ~~F~~
~~the~~ ~~length~~ ~~of~~ ~~the~~ ~~line~~ ~~BF~~ ~~is~~ ~~the~~ ~~height~~ ~~of~~ ~~the~~
~~hip~~ ~~and~~ ~~is~~ ~~equal~~ ~~to~~ ~~the~~ ~~height~~ ~~of~~ ~~the~~ ~~hip~~
~~the~~ ~~line~~ ~~BF~~ ~~is~~ ~~at~~ ~~an~~ ~~angle~~ ~~of~~ ~~45~~ ~~degrees~~
~~with~~ ~~the~~ ~~vertical~~ ~~side~~ ~~of~~ ~~the~~ ~~roof~~
~~and~~ ~~is~~ ~~equal~~ ~~to~~ ~~the~~ ~~length~~ ~~of~~ ~~the~~ ~~line~~ ~~DB~~. ~~DC~~
~~is~~ ~~equal~~ ~~to~~ ~~the~~ ~~height~~ ~~of~~ ~~the~~ ~~hip~~ ~~and~~ ~~is~~ ~~equal~~ ~~to~~ ~~FE~~.
~~the~~ ~~levels~~ ~~for~~ ~~the~~ ~~rafters~~ ~~are~~ ~~found~~ ~~by~~ ~~drawing~~ ~~the~~ ~~line~~ ~~AC~~ ~~on~~
~~the~~ ~~plan~~ ~~of~~ ~~the~~ ~~roof~~.

By the ~~construction~~ ~~the~~ ~~use~~ ~~of~~ ~~the~~ ~~line~~ ~~jack~~ ~~from~~
~~the~~ ~~center~~ ~~of~~ ~~the~~ ~~arc~~ ~~BF~~ ~~is~~ ~~drawn~~ ~~up~~ ~~to~~ ~~AC~~ ~~as~~ ~~shown~~.
~~the~~ ~~point~~ ~~where~~ ~~the~~ ~~line~~ ~~BF~~ ~~intersects~~ ~~the~~ ~~line~~ ~~AC~~
~~is~~ ~~the~~ ~~common~~ ~~height~~ ~~of~~ ~~the~~ ~~rafters~~ ~~and~~ ~~is~~ ~~the~~ ~~height~~ ~~of~~ ~~the~~ ~~jack~~. ~~The~~ ~~seat~~
~~and~~ ~~the~~ ~~height~~ ~~of~~ ~~the~~ ~~rafters~~ ~~is~~ ~~found~~ ~~as~~ ~~for~~ ~~the~~ ~~com-~~
~~mon~~ ~~height~~ ~~of~~ ~~the~~ ~~rafters~~ ~~is~~ ~~found~~ ~~is~~ ~~drawn~~ ~~across~~
~~the~~ ~~plan~~ ~~of~~ ~~the~~ ~~roof~~ ~~to~~ ~~be~~ ~~the~~ ~~height~~ ~~of~~ ~~the~~ ~~hip~~.
~~the~~ ~~height~~ ~~of~~ ~~the~~ ~~rafters~~ ~~is~~ ~~found~~ ~~by~~ ~~drawing~~ ~~the~~ ~~line~~ ~~FE~~,
~~as~~ ~~shown~~ ~~in~~ ~~the~~ ~~diagram~~.

It will be seen that BF equals AC , and may, therefore, be taken for the length of the jack.

For the backing of the hip, lay off one-half of the hip's thickness from D on line DB west end will give the gauge line or the amount to remove to a center line at top of the hip.

Octagonal Roofs—Fig. 52 represents an octagonal roof. In its construction the suggestions following, on octagons, must be referred to.

To find the side of an octagon when the side of the square is given. Multiply the side of the

square by 4.97 and divide by 12. The quotient is the side of the inscribed octagon.

To continue with an octagon roof; the length of hips is found as usual from rise and run, the run being half the diagonal of the octagon. Cut

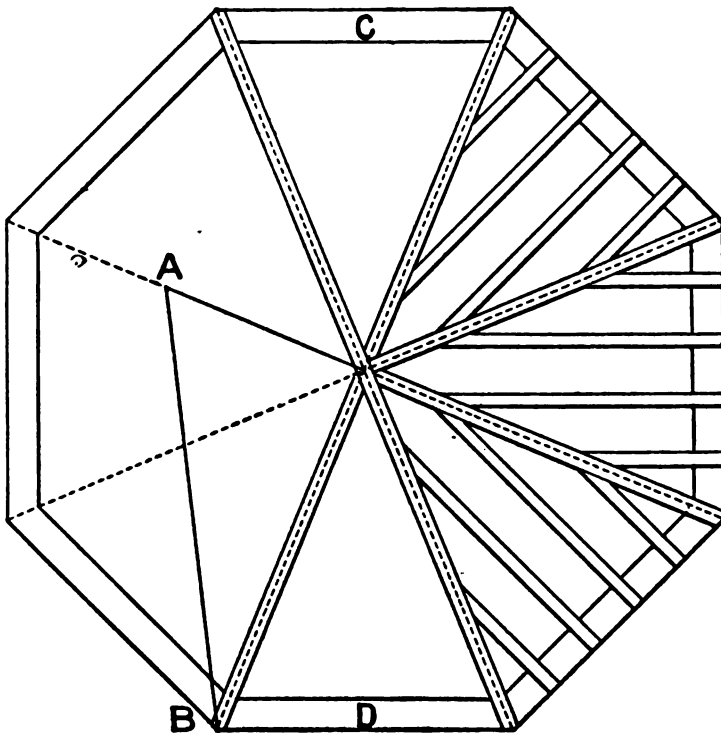

FIG. 52

the first pair full length to butt against each other; the next pair are to be set up at right angles to these, and each is to be cut shorter than the first pair by half the thickness of first

412410

pair, measured square back from the down bevel. The third and fourth pairs are to be cut shorter than the first by half the diagonal of a square whose side is the thickness of the first rafters. If the thickness of the first pair is 2 inches, then the third and fourth pairs are shortened by 1 and 5-12, as 2 and 10-12 is the diagonal of a square whose side is 2.

The first and second pairs have no side bevels; the side bevels of the third and fourth run back on both sides from the middle of the rafter. Find this bevel by taking the original length of rafter on blade and its run on the tongue, when the blade shows the cut. The backing of the hips obtain by taking 5-12 of the rise on the tongue and the length of hip on blade, the latter giving the bevel; for the side of an octagon is 5-12 its square width.

Half the square width is the run of the middle jack rafter, from which and its rise we get its length. From the length deduct the same amount as from the third and fourth pairs of hips. If there are to be two jacks between the middle one and the corner, we divide the length of side into three parts, also the rise, whence are obtained as before the distance of rafters apart, and the rise of the shortest jack. Divide half the square width of octagon by three to find the run of shortest jack. Just as the square is laid on to find the length of a jack, it gives the down and lower end bevels; while the side bevel is obtained by taking length of middle jack

on blade and half one side of the octagon on the tongue; the blade giving the cut.

Lengths and Bevels of Hips and Jacks.—The following illustrations and reading matter are from Mr. Woods' pen and are largely self-explanatory. They show the lengths and bevels of hips and jacks for an octagonal tower roof. The seat and plumb cuts are found in the usual way of taking the proportion of the run and rise on the tongue and blade but there must be an additional or diagonal cut across the back of the jack to fit against the hip, as shown in Fig. 53 by the dotted lines at A-B. These lines are always vertical and the same distance apart regardless of the pitch

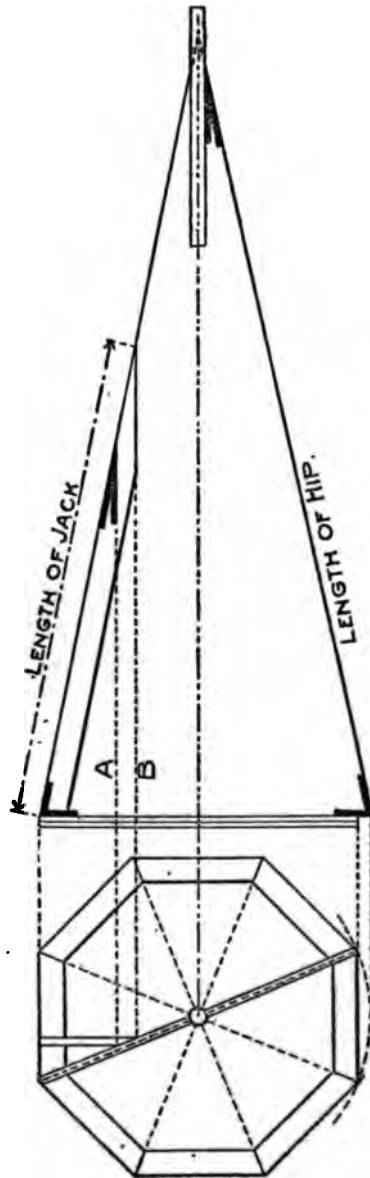

FIG. 53

half one
 stagon on
 he blade
 t.

nd Bevels

Jacks.—

g illustra-
 ding mat-
 Mr. Woods'
 are largely
 tory. They
 lengths and
 hips and
 n octagonal

The seat
 o cuts are
 the usual
 ng the pro-
 he run and
 e tongue
 but there

addition-
 onal cut
 back of
 fit against
 shown in
 he dotted
 B. These
 ways ver-
 the same
 part re-
 the pitch

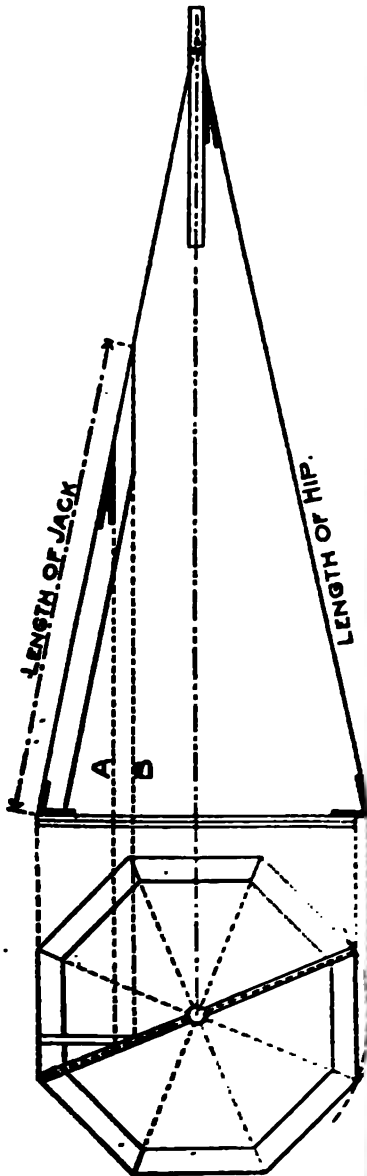

FIG. 53

given. A diagonal line from A to B across the back of the jack determines the angle.

Fig. 54 illustrates this point. If there were

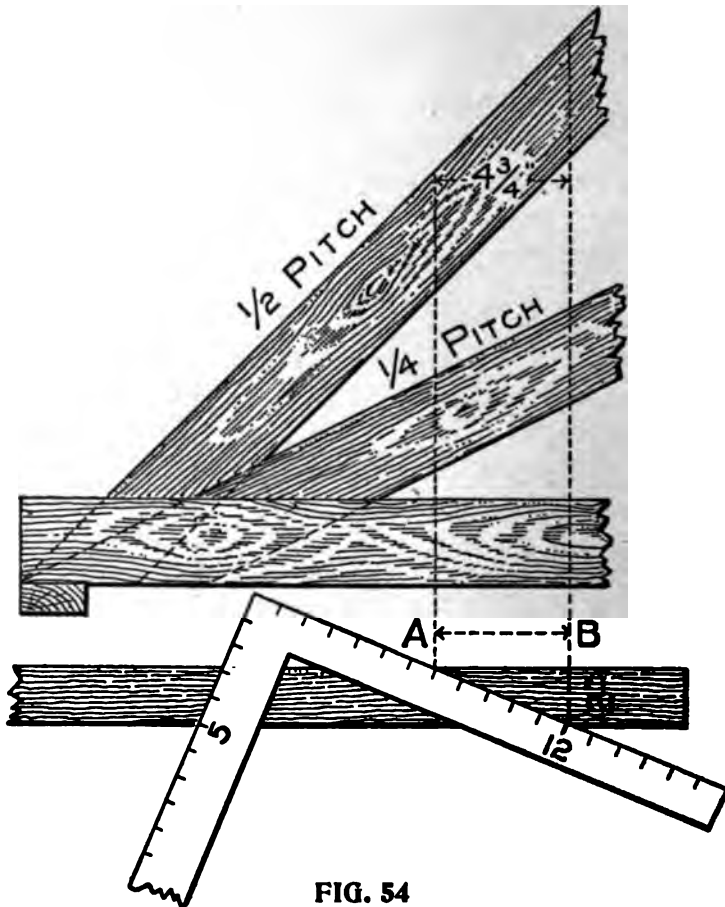

FIG. 54

no pitch at all then 5 and 12 would give the cut. These figures also give the starting lines A and B, which, since the rafters are of the same thick-

ness, will remain at right angles the same distance apart. Thus, if the rafter be 2 inches thick, the lines A and B will be $4\frac{1}{2}$ inches apart.

The jack cut may also be found as follows: Take 5 on the tongue and the length of the common rafter for one foot run on the blade, the blade giving the cut. Thus it will be seen that when the principles of roof framing are understood it is not necessary to lay out an

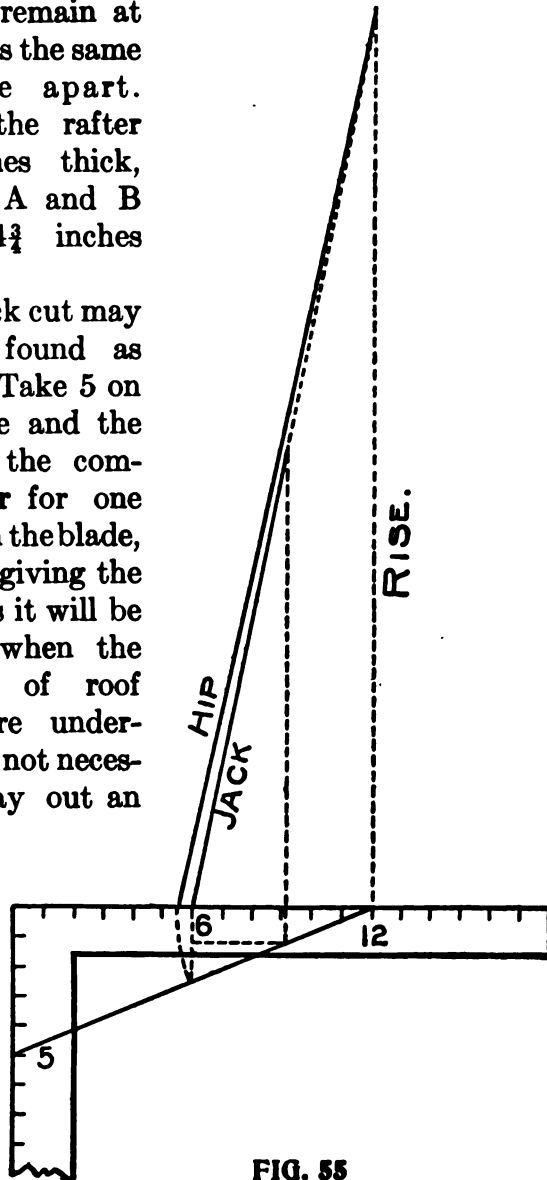

FIG. 55

elaborate diagram. A simple line drawing like that shown in Fig. 55 illustrates all that is contained in Fig. 53.

In the plan shown in Fig. 53 it will be seen that the hips do not come to a common center within themselves, but instead are resting against a center piece which may be a finial or flag pole, and in that case furnishes an excellent bracing for same, but when this is used the lengths of the hip must be shorter. The best way to obtain this is to find the full length of the hip and lay off the plumb cut and from this at right angles measure off one half the thickness of the pole, which will give the proper point of the plumb cut. When this pole is omitted the common way is to let one pair of the hips butt against each other as shown in Fig. 56. The runs are reckoned from the outer edge of the plates to the center, as GO for the common rafter and OF for the hip, but since all of the rafters do not run to the center there must necessarily be a deduction from the runs, as given above.

In the plan it will be seen that only one set of the hips (No. 1), meet at the center. Set No.2 lacks the thickness of No. 1 of coming together, or an amount equal to OA taken from the run of each rafter. The next two sets, No. 3, are of the same length, and the deduction for this is equal to OB plus BC to obtain the plumb cut for the side bevel. The run of the common rafter, No. 4, being GO the deduction from which is

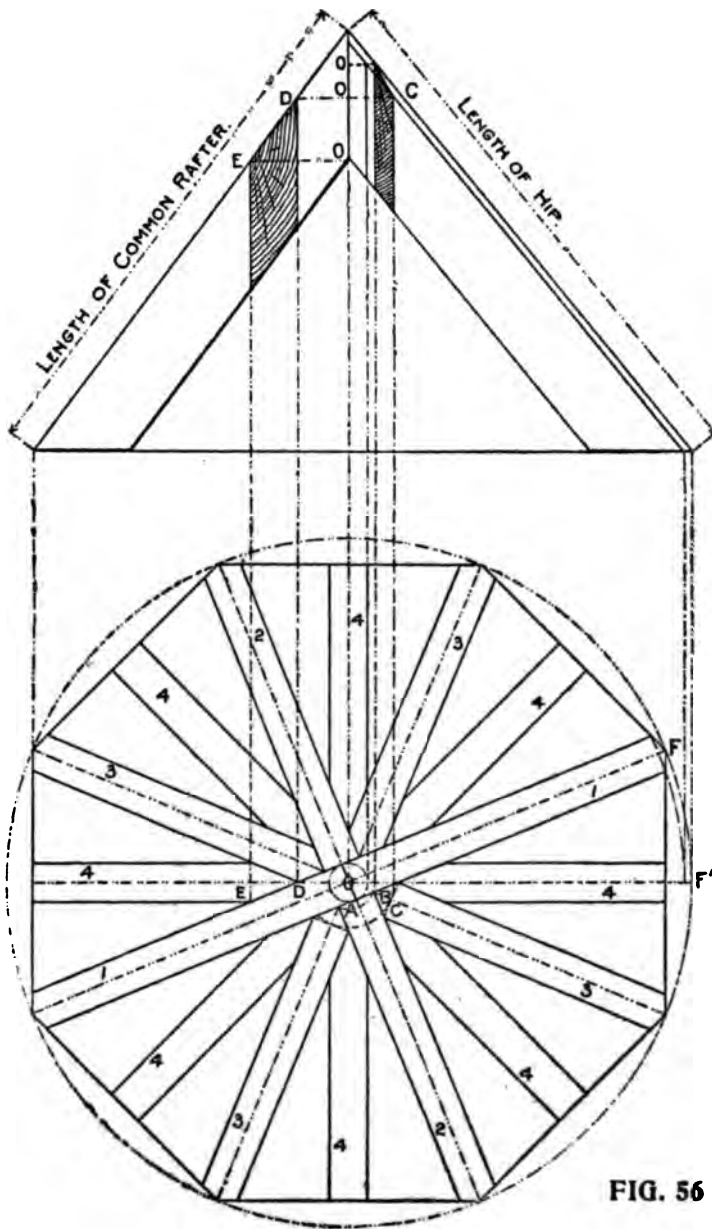

FIG. 56

equal to DO plus ED to obtain the plumb cut for the side level.

Now, referring to the elevation, the above reference letters are used for like measurements, showing the proper deductions to be made to obtain the lengths for the different rafters by simply squaring back the above amounts from the plumb cut for the full length rafter.

The run and rise taken on the square regulate the seat and plumb cuts, but the above deductions remain the same for any pitched roof.

To Obtain Length of Various Rafters for Any Width of Building.—In Fig. 49a, we gave an illustration showing the comparison of the runs of the octagon hip and for a hip resting on a square cornered building, to that for a one-foot run of the common rafter.

Now since these lengths taken diagonally from 12, 13 and 17 on the tongue to the figures designating the rise on the blade represent the lengths of the rafters for a one-foot run, it is an easy matter to find the lengths for any run by simply multiplying the lengths given by the number of feet and fraction of a foot in the run, and point off as many figures in the product as there are decimal figures in the solution and reduce to feet and inches. The finding of the length for a fractional part of a foot in the run may be avoided by finding the length only for the number of feet as described above and lay off a plumb cut, then from this measure square out the amount of the fraction, which will be the

point for the proper plumb cut. Or the calculation in figures for the whole length may be avoided by running the square as shown in Fig. 56a. In this is shown a rafter with a 6-foot 6-inch run and a 9-inch rise, or $\frac{3}{8}$ pitch. Apply the steel square six times as shown, then measuring

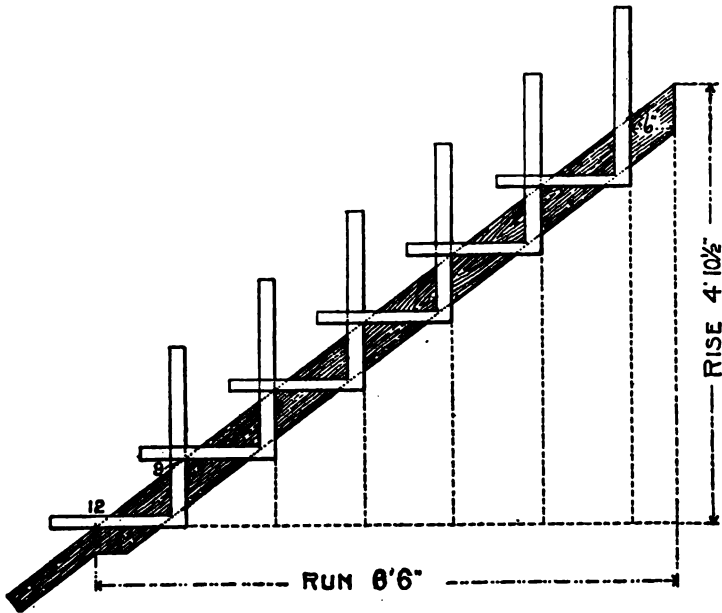

FIG. 56A

six inches square out from the last application of the steel square, will give the point for the plumb cut. Proceed in like manner for the corresponding hips, using the figures 13 and 17 on the tongue respectively for the octagon and common hip or valley, but instead of measuring six inches square out as for the common rafter, it

must be to the ratio of 13 and 17, as 6 is to 12 inches.

Therefore in this example, it would be $6\frac{1}{2}$ inches for the octagon hip and $8\frac{1}{2}$ inches for the hip, or valley, for the square cornered building.

In Fig. 56b are shown these proportions in connection with the steel square. The run of the hip for a square cornered building rests at 45° from that of the common rafter and that for the octagon hip at $22\frac{1}{2}^\circ$ degrees. So then, we let the tongue of the square represent the run for the common rafter, and by laying off the diagonal lines to 5 and 12 (the figures that represent the degrees) on the blade, and by squaring up six inches to the right of the starting point (12 on the tongue) it will be seen the diagonal lines are cut at the center of their lengths.

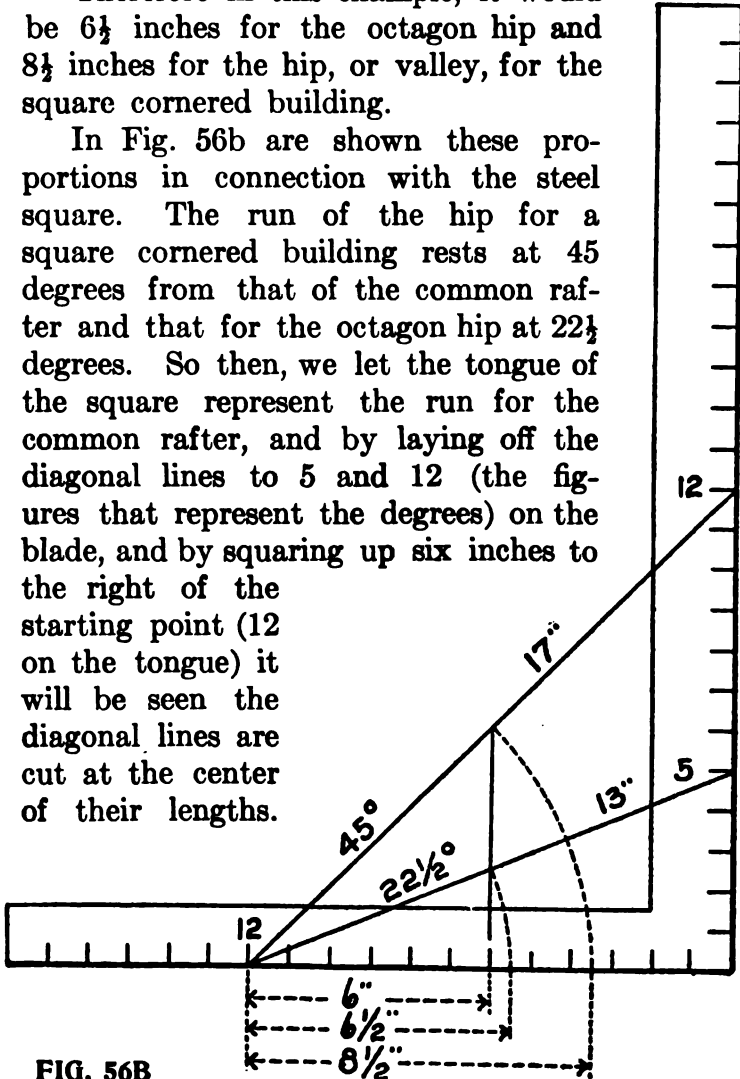

FIG. 56B

Therefore, one-half of their lengths represents the amount to square out to correspond with a six-inch run of the common rafter.

This proportion exists at any point that may represent the fraction of a foot in the run. If the fraction be one inch, the scale is then reduced to one-twelfth of the full size, and these lengths are simply read as twelfths inches, instead of inches.

Great care should be exercised in making measurements as shown in Fig. 56a, as it is a very easy matter to get off a little each movement of the square, and for that reason it is better to multiply the decimal lengths given in Fig. 49a.

For example we will find the length of the rafter shown in Fig. 56a. By referring to the table in Fig. 49a, we find the length for the common rafter to be 15 inches. Then $15 \times 6\frac{1}{2} (6.5) = 97.5$ inches, or 8 feet $1\frac{1}{2}$ inches. For the corresponding octagon hip, the length is 15.81 inches. Then $15.81 \times 6.5 = 102.765$ inches, or 8 feet $6\frac{3}{4}$ inches. Bear in mind that the 102 is inches and that 12 goes into 102 eight times and six over, making 8 feet 6 inches, and the .765 is only a fractional part of an inch and is equal to only a little over three-quarters of an inch. See table of equivalents in Fig. 49a. For the corresponding common hip or valley, the length is 19.21 inches. Then $19.21 \times 6.5 = 124.865$ inches, or 10 feet $4\frac{7}{8}$ inches. While the lengths, 15, 15.81 and 19.21, given above, represent the rafters for one-foot run, they may also represent the length of the

rafters for one-inch run, as before mentioned, and in that case the lengths given above would be so many twelfths of an inch and the decimal fractions would only be fractions of a twelfth of an inch. Thus, to find the lengths of the hip for a 7-inch run, would be $19.21 \times 7 = 134.47$ twelfths inches, equal to 11 2-12 inches. The .47 is discarded because it is less than one-half of a twelfth of an inch. This also applies to finding the common difference in the length of jacks. Since a jack is simply a part of a common rafter, it is only necessary to multiply the length of the common rafter (15) by the number of inches in the spacing and divide by 12, will give the answer. Thus—if the jacks be placed 16 inches on centers $15 \times 16 = 240 \div 12 = 20$ inches, will be the length of the first jack or the common difference for a roof with a 9-inch rise. As this example is without fractions, we will give another, taking that for the 8-inch rise or 1-3 pitch. In this, the length of the common rafter is 14.42. Then $14.42 \times 16 = 230.72 \div 12 = 19$ 2-12 inches, and is the answer. To find the common difference for the octagon jack for the above pitch, proceed in like manner, but multiply 14.42 by 2.4 and the product by the spacing and divide by 12 will give the answer. Thus $14.42 \times 2.4 = 34.608 \times 16 = 553.728 \div 12 = 46$ 1-12 inches. The decimal fractions in the two last examples are discarded for the same reason as before described. These lengths are calculated to a center line at the ridge and at the center of the back of the hip or valley.

Therefore, reductions should be made from the lengths here calculated by squaring back from the plumb cut one-half the thickness of the ridge board, which will give the point for the proper cut for the common rafters and jacks that fit against same. For the jacks that fit against a hip or valley for a square cornered building, deduct one-half the diagonal thickness of the hip it rests against, by measuring square back from the plumb cut. Rafters are usually about $1\frac{3}{4}$ inches thick, and the proper reduction in that case would be practically $1\frac{1}{4}$ inches. However, the jacks will fit just as well though they will be one-half of their thickness out of their regular spacing, or if the measurement line is taken on the long side of the jack, then they will be of the proper length without any reduction.

Different Kinds of Jacks Described.—There are several kinds of jacks and while we are at this point it might be well to describe them. They are known by the position they occupy as follows: A jack with the upper end resting against a hip is called a hip jack. A jack with the upper end against the ridge board and the lower end against the valley is called a valley jack.

A jack cut in between a hip and a valley is called a hip and valley jack, or more generally known as a cripple jack. The latter in many cases is a very appropriate name, however, we prefer to call them by the former name.

In Fig. 56c is shown a plan of these jacks.

The measurement line is at the center of the back in each case and shows all of them to be for the same length of run, the dotted lines showing the amount of the reduction to be made to fit to their proper place. In this, it will be seen that the cut across the back of the jacks (commonly called side cut) is at an angle of 45 degrees

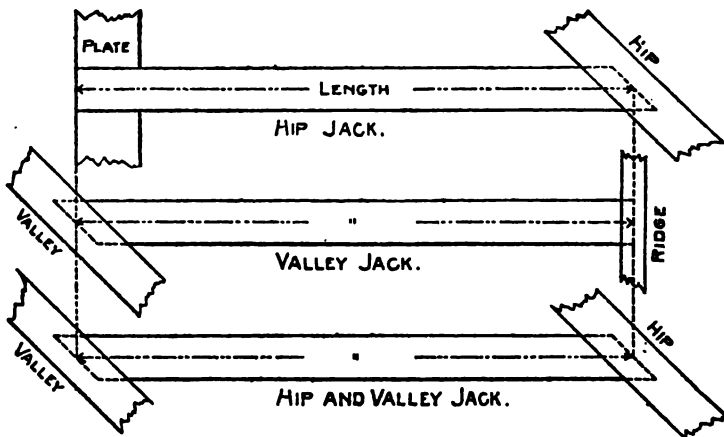

FIG. 56C

and this remains so regardless of the pitch given the roof. Therefore, the side cut of a jack, in one sense of the word, is a miter just the same as for a square-cornered frame. To prove this, after the side cut has been made for any pitch, cut off the peak end of the rafter on a line parallel with the seat cut and it will be seen that the angle is at 45 degrees, just the same as shown in the plan.

Hexagonal Roofs.—Take 6 and fifteen-sixteenths on the tongue and 12 inches on the blade,

and apply as shown in Fig. 57, and it will give the miter.

The side of a hexagon equals the radius of the circumscribing circle. The square width is

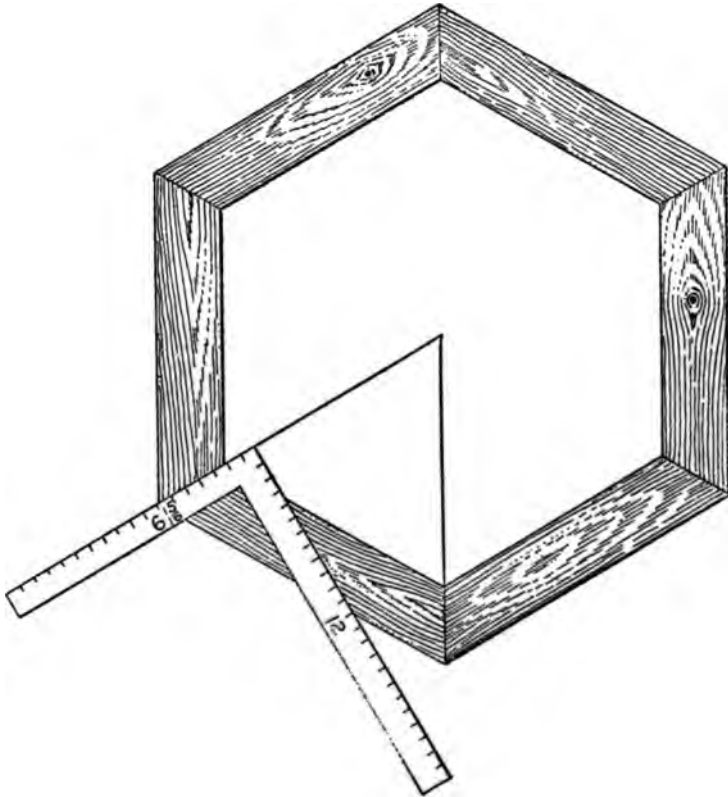

FIG. 57

determined from two parallel sides; a diagonal of the figure, is a line from opposite angles. The first pair of hips are set up as in an octagonal roof. The second and third pairs have a side bevel. To

find this, take half the side of the hexagon on the tongue and half the square width added to the gain of the hip-rafter in running that distance, on the blade. The tongue gives the cut. Strike the bevel across the rafter. Now, the second and third pairs are to be measured back

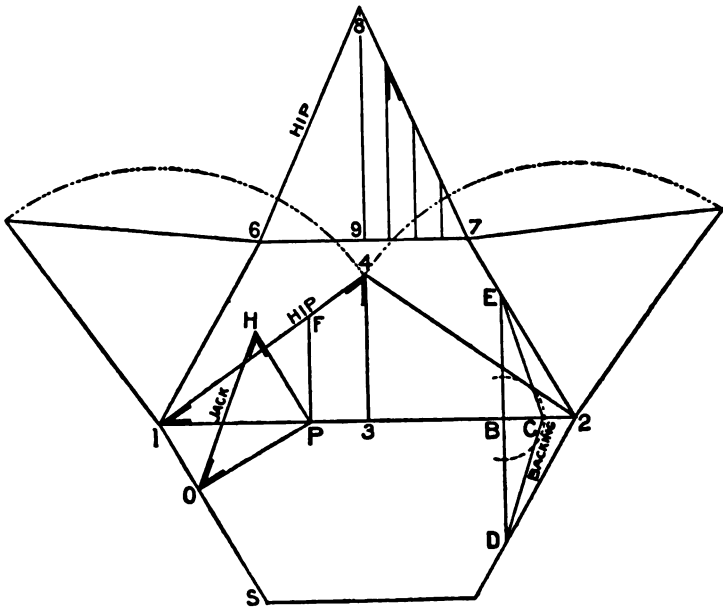

FIG. 58

shorter than the first pair, on their middle lines, just half the length of this bevel. The third pair has the bevel cut on both sides from the center. The backing of the hips is found by taking 7-12 the rise of roof on tongue and the length of hip on blade; the latter gives the cut. The side of the hexagon is 7-12 its square

width, or apothegm. The lengths and bevels of the jack-rafters are found as in octagonal roofs.

To Timber a Hexagon Roof.—On the line 1-2, Fig. 58, is the seat of the hips, 3-4 will be the rise. On the line 1-S say at O, draw a line at right angles touching the line 1-2 at P which is the seat of a jack rafter. From O-P at right angles draw P-H equal to P-F, and connect OH: this gives the length, seat and plumb cut of jack rafter. From 6-7 draw the line 8-9 indefinitely; set the compasses to 1-4, which is the length of the hip, and this length at 6 intersect 9-8 at 8, repeat from 7, which is the covering for one side of the roof, the intermediate lines being the lengths of jack rafters and bevels for side cut. On the line 1-2, say at B, take B for a center, touching the line 4-2, for radius, describe the arc BC; through B, at right angles to 1-2, draw the line DE, and from C to E and C to D will be found the bevels for backing the hips.



Part VI

HOPPERS AND HOPPER BEVELS

Laying Out Hopper Bevels with a Square—The Various Classes of Hoppers—Methods of Finding the Bevels and Width of Sides and Ends of a Square Hopper—Rule for Finding the Bevels for the Butt Joint of the Hopper—Cuts and Bevels for Flaring Hopper—Angles and Bevels for Hopper Work—Mitters—Methods of Finding the Miter—Trusses—Tower for Windmill, etc.

Laying Out Hopper Bevels With the Square.
—The subject of hopper bevels is one that is not generally understood among workmen. We have known good mechanics who could frame complicated hip and valley roofs but when it came to laying out hopper bevels with the square, they were, so to speak, at sea. Yet the same principle involved in the framing of a hip-roof applies to a hopper—that is, a hip-roof inverted is a hopper. The roof boards that fit in the valley over the hip form the hopper joint. However, there are many ways of arriving at the cuts, and we will here present the views of various writers on the subject; many have been published before, but we give them here because the progressive mechanic is not a “one way man,” but wants to know the different ways of obtaining the same result, from which he can select the way that best suits his purpose. The following illustra-

tions in Figs. 59 to 64 represent the various classes of hoppers.

Fig. 59 represents a cottage, the roof of which is an inverted hopper.

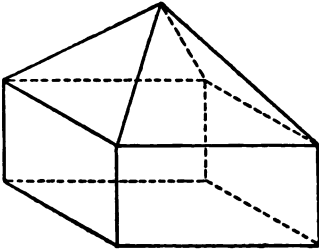

FIG. 59

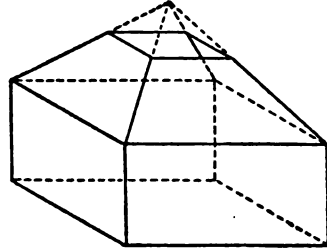

FIG. 60

Fig. 60 represents the same, showing the roof part only, with the apex taken off, which may be the bottom of the hopper.

Fig. 61 represents the hopper in its natural position.

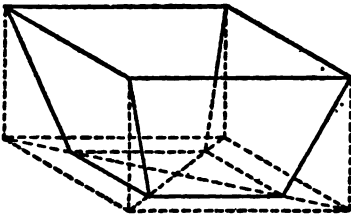

FIG. 61

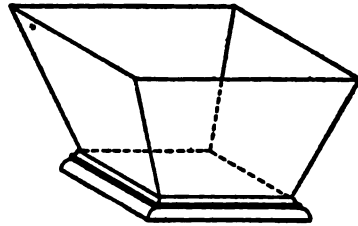

FIG. 62

Fig. 62 represents a rectangular hopper with projecting bottom piece, and Figs. 63 and 64 represent the same for the triangular and hexagonal hoppers.

The following method of finding the bevels and width of sides and ends of a square hopper is from Mr. Connell.

In Fig. 65 the large square represents the upper edges of the hopper and the small one the lower edges or base. The width of the sides and ends is found in this way: Take the run ab on the tongue, and the perpendicular height ad on the blade. It is thus found in the same manner as the end of a brace. To find the cut for a butt

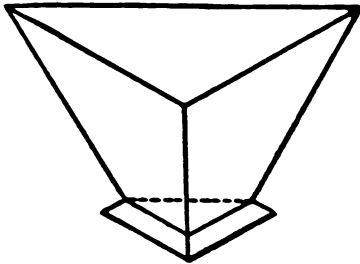

FIG. 63

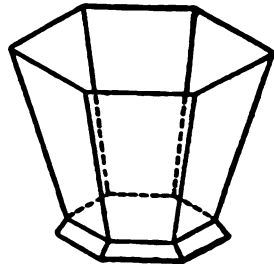

FIG. 64

joint, take the width of side on blade and half the length of the base on tongue; the latter gives the cut. For a miter joint take width of side on the blade and perpendicular height on tongue; the latter gives the cut.

For the cut across the sides of the boards, take the run ab on the tongue, and the width of side on blade; the tongue gives the cut. In case of butt joints the inside corners of the sides and ends are longer than the outside, so if a hopper is to be of a certain size, the lengths of ends and sides are to be measured on the inside

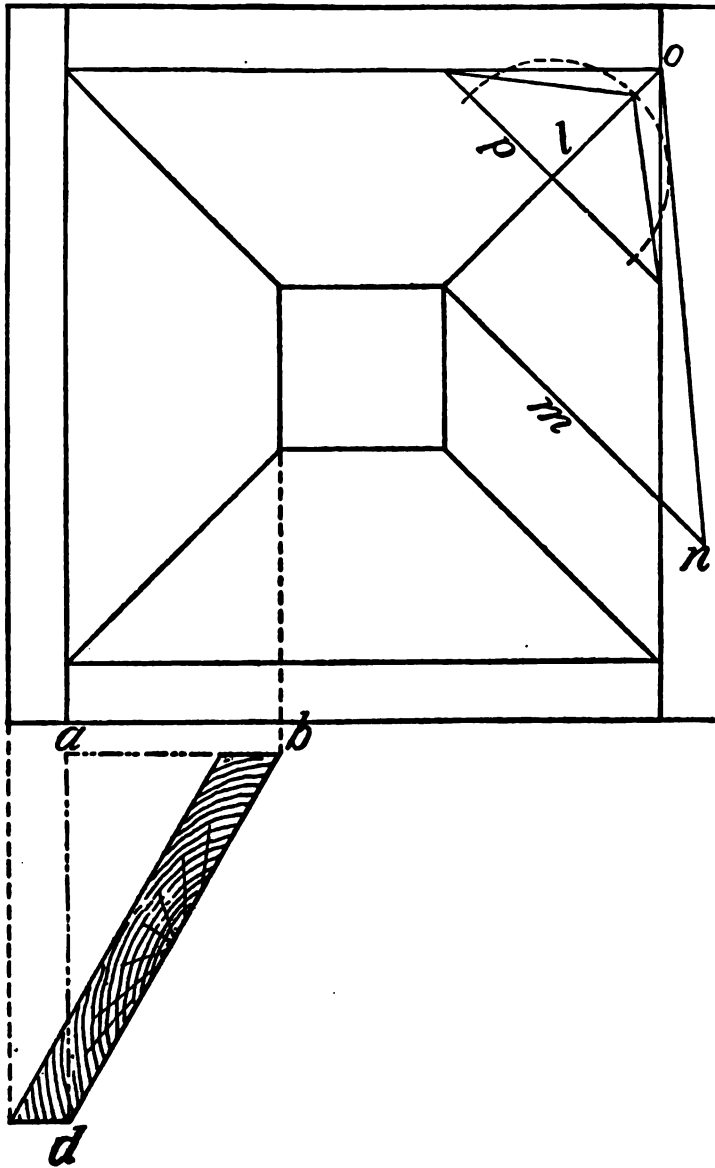

FIG. 65

edge of each piece, and the bevels struck across the edges to these marks. Of course if the hopper is to be square, the thickness of the sides must be taken from the ends.

If the top and bottom edges are to be horizontal, the bevel is thus found: Take the perpendicular height of hoppers on the blade and the run on the tongue, the latter gives the miter cut, in other words it is the 45 degree angle.

In large hoppers, pieces are put down along the corners to strengthen them. The length, and the bevel to fit the corner are thus found: Suppose the top of hopper is 8 feet, and the bottom 18 inches square. Find the diagonals of each, subtract the one from the other, and half the remainder is the run for the corner piece. From the length of this run, L , and the rise, ad , we find the length of the corner piece. To find the bevel or backing, take on the blade the length of the corner piece and on the tongue the rise; the latter gives the bevel. Another method is to draw the line, L , to represent the seat of the corner piece, set off square with this the line m , of the same length as the rise, ad . Then draw $n-o$, which is the length of the corner piece. To find the backing, draw a line, p , anywhere across L , strike a circle tangent to $n-o$. From the point of intersection of the circle with L , draw lines to the extremities of p . The angle made by these lines is the bevel or backing. From this it can be readily seen that the principles involved

are the same as those for finding the length and backing of the hip rafter.

Another method generally employed for finding the bevels of hoppers is to bevel the top and bottom edges of the sides and ends to the angle they are to stand at, then to lay a bevel set to a miter, or angle of 45 degrees, on the beveled edge, and that will lay off a miter joint, while a try-square will lay off a butt joint; otherwise an angle of 45 degrees will miter only those boxes with sides which are vertical and square with each other.

When a hopper has the sides and ends of different widths, that is, when sides and ends stand at different angles, both having the same rise, find the cuts for each from its respective rise, run and width.

In the preceding it has been shown how the bevels and lines for hoppers may be obtained by the aid of the square, and it is now proposed to show how the same results may be obtained by a system of lines. This method, in many shapes and forms, has been used from time immemorial by workmen, more particularly by carriage makers to obtain the bevels of splayed seats; the present way of expressing it is, however, comparatively recent. If we make A1, Fig. 66, represent the elevation of our hopper, and B1 a portion of the plan, we proceed as follows: Lay off NS, which is the bevel of one side, and NSPO the section of one end.

Place one foot of the dividers at N, and with

NS as radius describe the arc SU, intersecting the line NU in the point U. At S erect the perpendicular ST, and draw the line UT at right angles to NU. Connect N and T; then the triangle MNT is the end bevel required. The line NT is

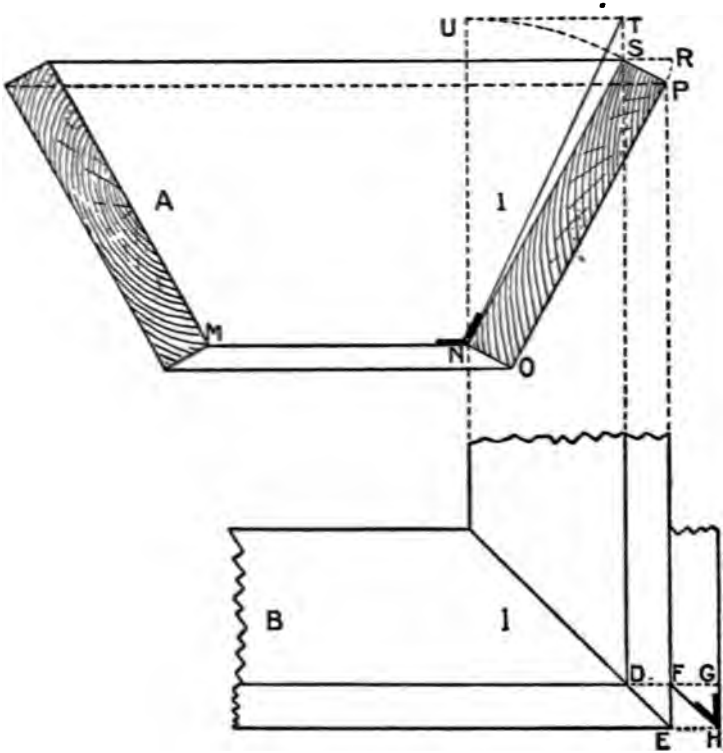

FIG. 66

the hypotenuse of a right-angled triangle, of which NU may be taken for the perpendicular and UT for the base. To find the miter of which DE is the plan, project S and P, as indicated in the plan by full lines. With SP as radius and

the inside edge is required to be than the outside. In the plan draw TV parallel to SX, making the distance between the two lines equal to CF of the elevation, or, equal to the thickness of one side. From the point L in the elevation drop the line LW, producing it until it cuts the miter line NO, as shown at W. From W, at right angles to LW, erect a perpendicular WV, meeting the line TV in the point V. Connect V and U; then TVU will be the angle sought. This bevel may be found at once by laying off the thickness of the side from the line EM, as shown by NP

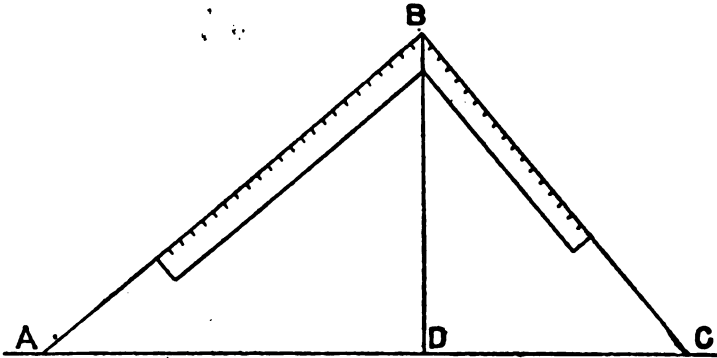

FIG. 68

in the elevation, and applying the bevel as shown. This course does away with the plan entirely, provided both sides have the same inclination.

There are several other ways by which the same results may be obtained, and some of these will no doubt occur to the reader when laying out the lines as shown here.

In Fig. 68 is shown another method for finding

the bevels for a square or rectangular hopper. Let AB always be the guiding line, and the one from which all the others take their positions, making that line equal in length the width of the side of the intended hopper.

To find bevel to cut across face of board: Take AB on blade and AD on tongue; bevel of tongue is the line required.

To find miter: Take AB on blade and BD on tongue, line of tongue is bevel sought.

For butt joint: Take BC on blade and AD on tongue, and line of tongue gives bevel required.

Cuts and Bevels for Flaring Hopper.—In order to make this department complete, we herewith give a method by which the cuts or bevels may be obtained for a flaring hopper having only three sides. In other words, Fig. 69 gives bevels for a box whose top and bottom form two unequal equilateral triangles: Make the triangle CEF, then from the middle point of EF let fall the perpendicular BD, then draw AB parallel and equal to CD, also AC parallel and equal to BD, thus forming the rectangle A, B, C, D. Now draw CH to the same inclination from CD, that a side of the box when finished will show from the perpendicular line; then draw LD perpendicular to CH, and, with C as a center and a radius CL, make an intersection at I, and connect I and A, and at A is the bevel for the miter at the ends. Again with D for a center and a radius DL, make an intersection at K, and connect K

and B; and at B is the bevel for the down or cross cut.

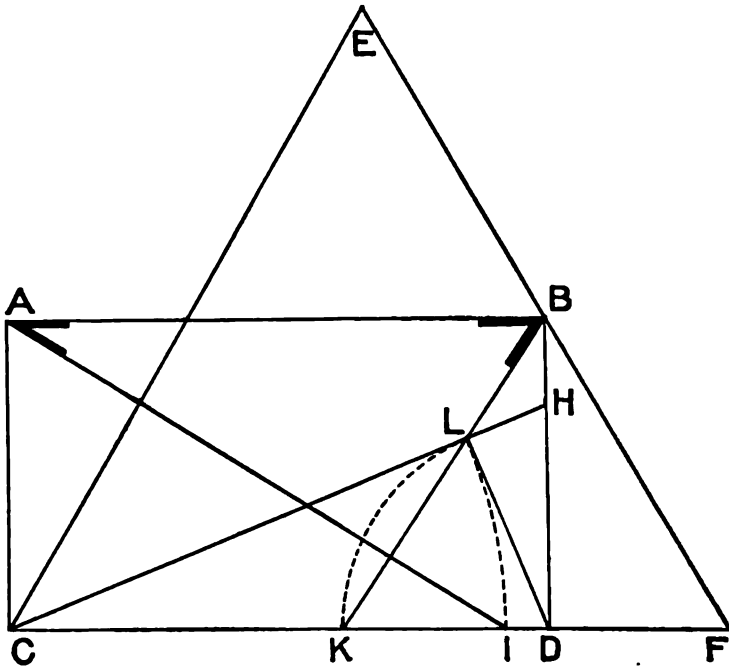

FIG. 69

To Find the Bevels Required to Miter Together the Flared Sides of a Hexagonal Hopper.—In Fig. 70, let NE be in the plane of the bottom of the hopper, and EJ the inclination of the sides; continue GD to B indefinitely; through J draw JO parallel to QD; through O draw AC at right angles to JO; make EM equal EJ; through M draw LC parallel to QD; make FH equal FJ; draw HA parallel to QD; through F draw FB

applied to other figures, such as pentagons, octagons, or other similar hoppers, where the flares are equal.

Angles and Bevels for Hopper Work.—Sometimes the student may get in a little maze when working out the angles and bevels for hopper work, as the operation is often perplexing, and like the rules for stair-building, which will come a little later, requires patience and steadiness. There is no reason, however, because of these matters appearing difficult at first, that they should not be thoroughly understood by any ordinary workman, after two or three trials.

The following is from an article by Mr. A. W. Woods, published in a trade paper a short time ago:

Hopper Cuts are similar to the cuts required for fitting boards in or over a valley or hip roof; consequently the figures on the square that give the cuts for the roof boards must give the cut for a hopper of the same pitch.

Fig. 71 shows a hopper in different views, as follows: Beginning at the top is the top view of the hopper. As far as this part is concerned all hoppers are alike, as there is nothing in this to distinguish the pitch. Next is the sectional or side view. In this is shown the thickness of the boards and the flare or pitch, which in this is the three-quarters pitch. Next is shown the four sides in the collapsible or ready to be put together, followed with the top view of the edge of the board.

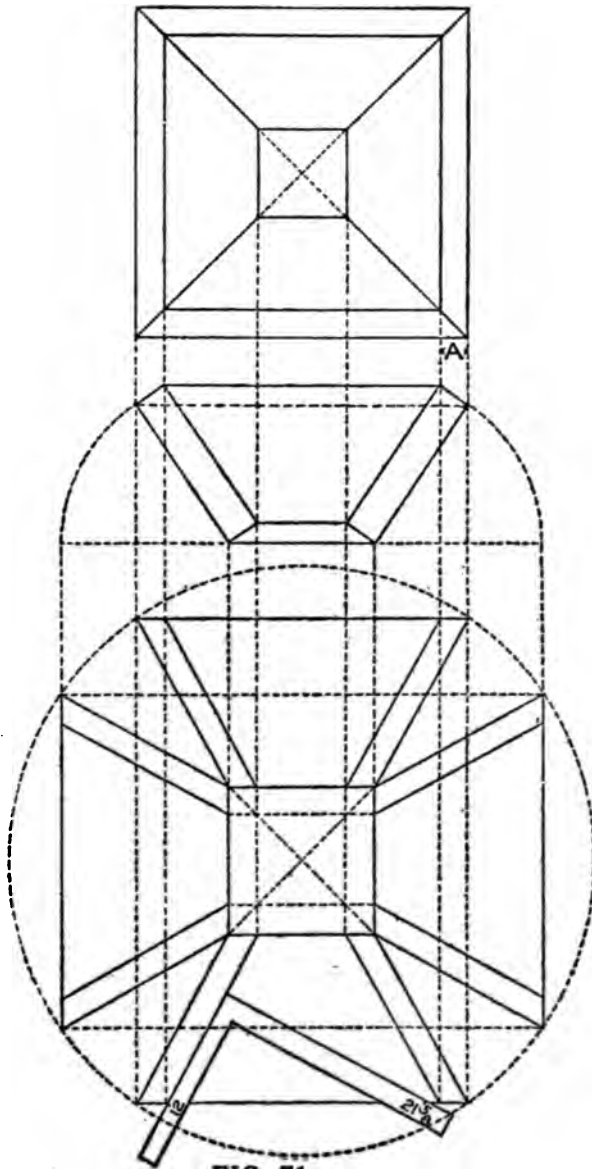

FIG. 71

Of course it is not necessary to lay out all of this diagram, or any of it for that matter; it is done by way of illustration. See the application of the square, which, in this case, is 12 and 21 and five-eighths. But why use these numbers? Because the flare given is the three-quarters pitch or 12 and 18 on the square, and the hypotenuse of these numbers is 21 and five-eighths, the tongue giving the side bevel. When working full scale it is always 12 on the tongue.

Miters.—For the miter bevel, the top edges should be first beveled so as to be level when in position. The miter would be at an angle

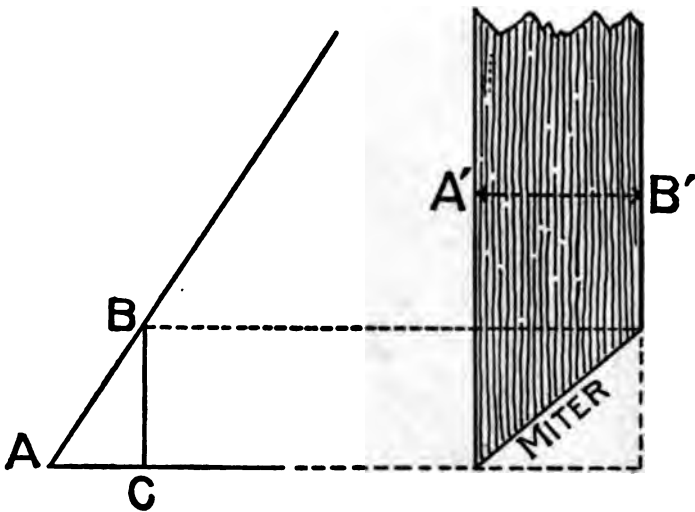

FIG. 72

of 45 degrees, and any of the equal numbers on the square gives this cut; but if the edges are to be left square with the sides, as shown, the above

will not work. To accomplish this, however, it may be obtained as shown in diagram at A, by setting off $\frac{1}{2}$ the thickness along the edge of the board, or as shown in Fig. 72 as follows: Lay off the base and the desired pitch, and on the latter measure the thickness of the board as at AB. From B draw a plumb line to base. BC is the width apart; the side bevels should be along the edge of the board.

In case of large hoppers to be built to suit some particular place, or regardless of pitch, it

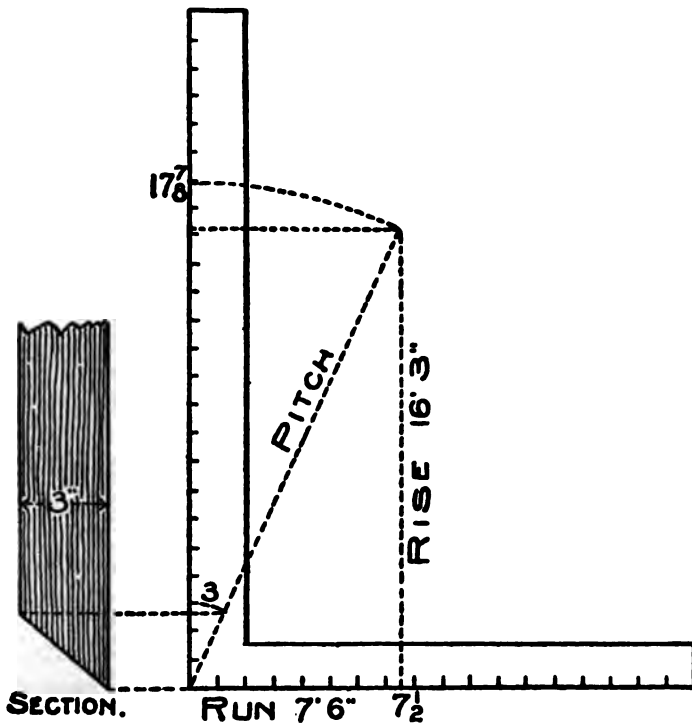

FIG. 73

is better to use the one-inch scale as illustrated in Fig. 73. For example, let 7 feet 6 inches be the run and 16 feet and 3 inches be the rise. Take $7\frac{1}{2}$ on the tongue and 17 and seven-eighths on the blade; the tongue gives the cut across the face of the board. Take 17 and seven-eighths on the tongue and 16 and three-twelfths on the blade and the tongue gives the cut across the edge of the board to form the miter, or it may be found by diagram as shown in the section.

Methods of Finding the Miter.—Great as the steel square may be in the hands of the learned mechanic, it is only secondary to the compasses. It simply steps in as an aid in defining what has already been determined by the compasses and their divisions called degrees. Therefore, we cannot pass the compasses by and the part they play without giving them due credit.

It will be our aim as far as possible to illustrate the part each instrument plays, thereby helping the student to more readily grasp the subject.

The old time masters, who set the recognized standard in architectural proportion, based their calculations upon the diameter of the circle and its divisions. Miters are governed by the divisions of the circumference of the circle, and not alone by the figures on the square. Therefore, to unlock the great fund of information contained in the arms of the square, it must be done by degrees. There are 360 contained in the circumference of the circle, and any of the regular polygonal miters can be readily found by dividing 360 by the num-

ber of sides in the polygon, and the quotient will be the angle that the miters stand with each other, but in order to obtain the angle with the steel square it is only necessary to take one-half of the degrees contained in the circle, or 180, and this divided by the number of sides in the polygon will give the degrees to use on the square. The reader will notice that we use 12 on the tongue for all miters; the reason we do this is because

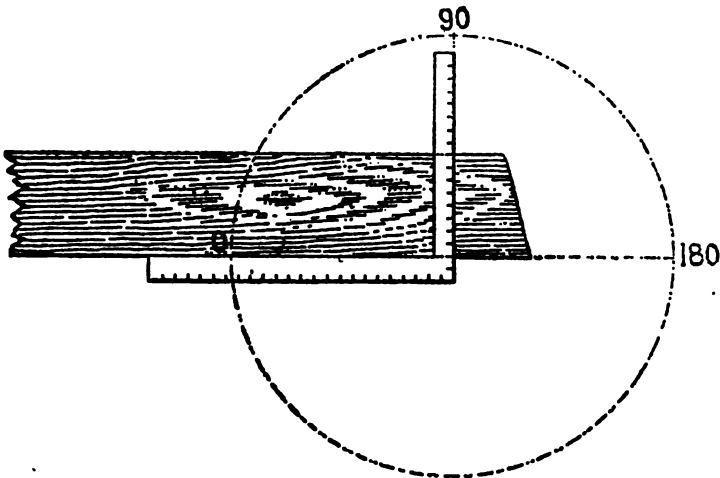

FIG. 73A

12 represents unity. It may represent one inch, one foot, one yard, or any other scale of measurement.

The casual observer sees nothing in the square beyond a simple measuring tool, or for squaring off the end of a board, which is the simplest of all the movements of the square. Yet as simple

as it is, it is governed by the degrees, as will be shown in referring to Fig. 73a.

In all cases a straight line, which may be the edge of a timber, represents one side of an angle from which the other side of the desired angle is reckoned, and in reality represents 180 degrees. Now, since the arms of the square set at an angle of 90 degrees with each other, just that much will it take from 180 degrees having the angle stand at 90 degrees as shown.

In Fig. 73b is shown the simplest of all miters, and it is used more than all others. The knowing

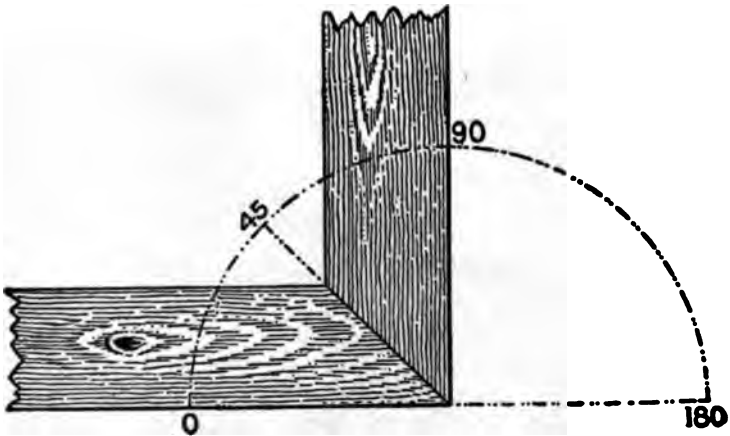

FIG. 73B

ones give the definition of the word miter as, "Joining two timbers at an angle of 45 degrees," without reference to any other angle. This is contrary to general belief and we see no reason why it does not apply equally as well to any other angle, and will treat them as such, but dividing

them into two classes, of regular and irregular miters. The former applies to polygonal corners, where the line of juncture is midway between

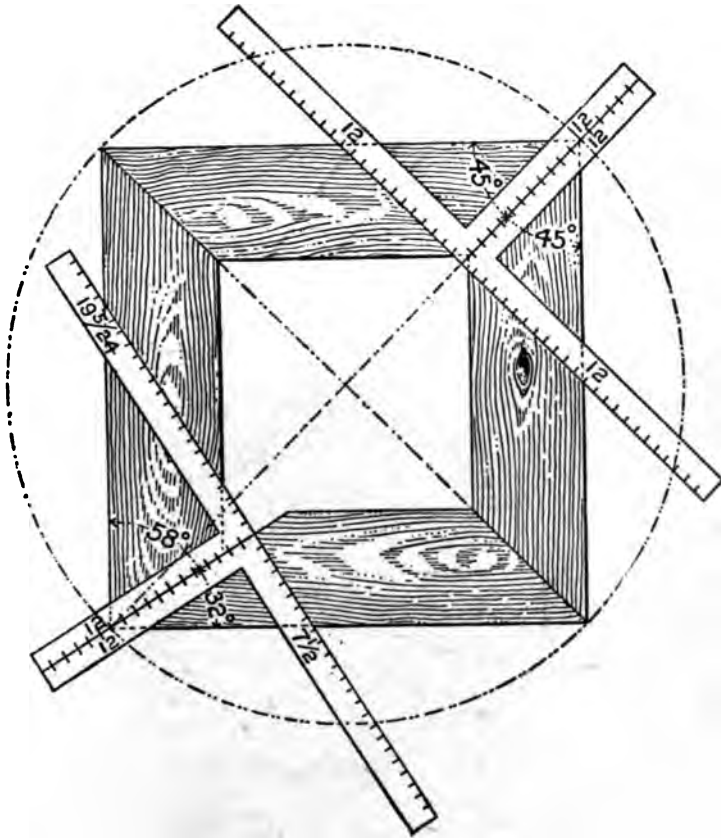

FIG. 73C

the outer edge of the timbers, as shown in Fig. 73b, and the latter to corners where the line of juncture does not rest midway between the outer

edge of the timbers, as shown in the lower left hand corner in Fig. 73c.

In this illustration we show both the regular and irregular miters for a square cornered frame, though it could be any polygonal corner. In this it will be seen that the regular miter is at 12 and 12 on the squares, and at 45 and 45 degrees from the edge of the timbers. In the irregular, the angle is at 58 and 32 degrees from the edge of the timbers, and on one of the squares it is at 12 and 19 5-24, and 12 and 7 1/2 on the other, but either of the squares gives the same result as far as the miter is concerned.

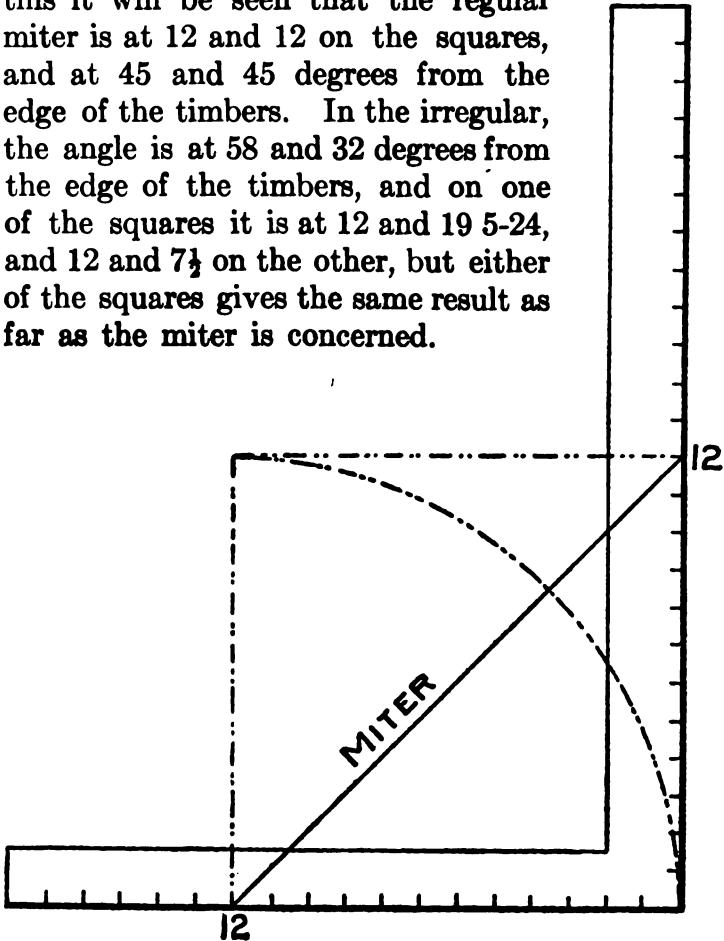

FIG. 74

The following is another article by Mr. Woods on bevels and hopper cuts generally, which owing to its excellency, we have thought worthy of

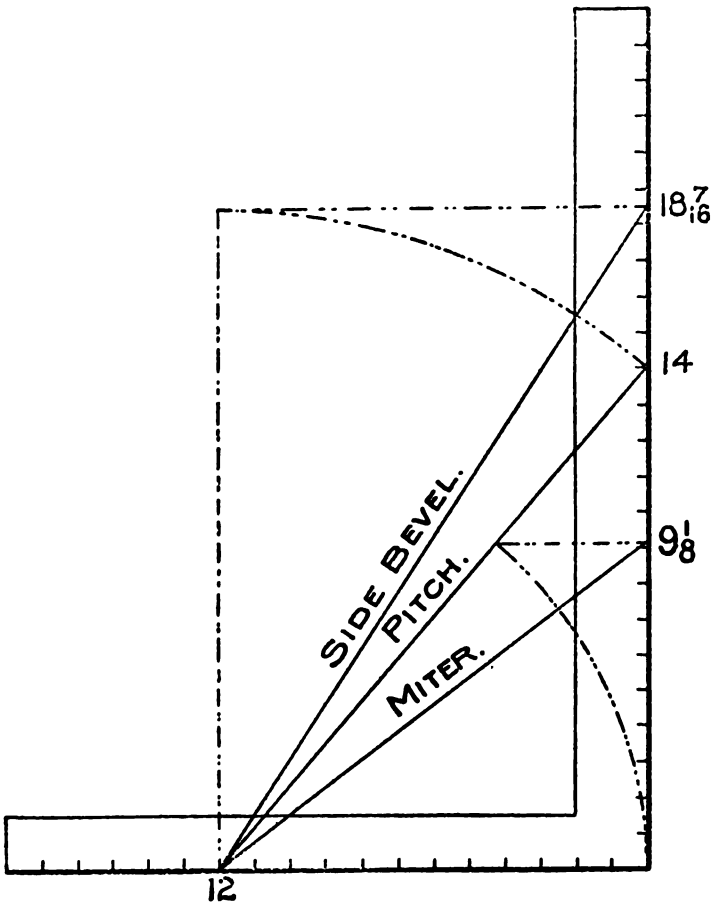

FIG. 75

a place in this work. The author starts out by saying: If there was no given pitch, then the sides would be vertical. Now with 12 on the

tongue as center, draw arc of same radius from the heel to a point directly above and square over the blade; 12 and 12 will give the miter, Fig. 74. Simple enough, but do you know that this simple rule applies when there is a pitch given? At the point where the arc intersects the pitch taken on the blade will give the miter, the blade giving the cut. See Fig. 75. For the side bevel across the board, transfer the length of the pitch to the blade, the tongue giving the cut. These figures also give the side cut of the jacks for a roof of same pitch. The blade in this case giving the cut.

Now we will give another method of finding the miter. In all roofs and hoppers there is an unseen pitch which we will call co-pitch. Assuming that the edges of our board are square the co-pitch would stand at an angle of 90 degrees with the given pitch. See Fig. 76.

The rule given in Fig. 75 for the side bevel will apply to the miter, but instead of using the length of the given pitch substitute that of the co-pitch, and by referring to Fig. 76 we find this to be $15\frac{3}{4}$ inches on the blade. Now for proof, see Fig. 77. Twelve and $9\frac{1}{2}$ first method, and 12 and $15\frac{3}{4}$ second method. The blade giving the cut in the former, and the tongue in the latter.

In Fig. 78 is shown all that is contained in the other figures, besides showing another pitch. It is an extension of the co-pitch to a point of the given pitch. This we will call complement

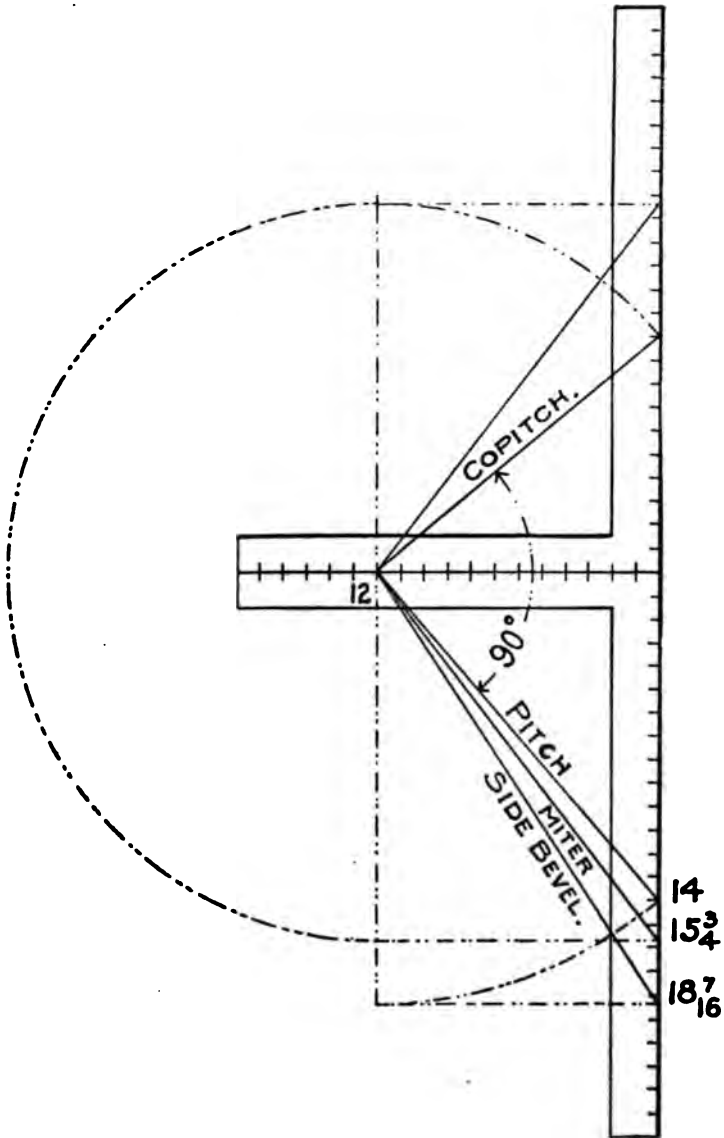

FIG. 76

In Fig. 79 is shown a diagram for a hopper of one-half pitch. In this all of the pitches are of equal length, therefore 12 and 16 and thirty-one-thirty-seconds will give all of the cuts; the

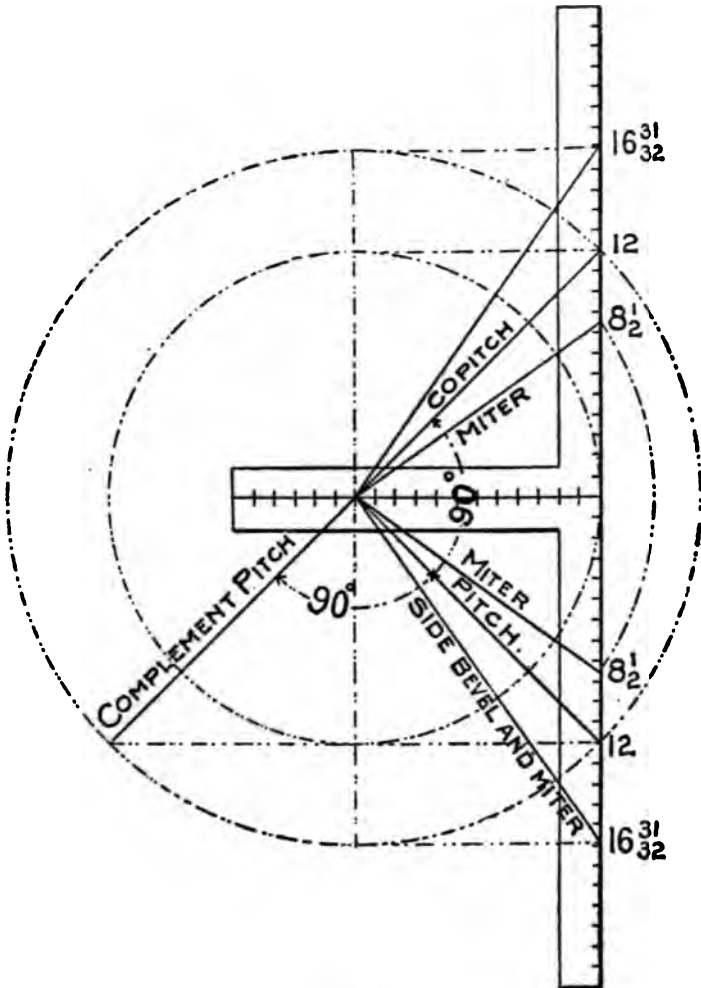

FIG. 79

tongue giving the cuts in each case. Fig. 80 and 81 are simply fillers and self-explanatory.

From the foregoing it will be seen that the standard of measurement is 12 on the tongue

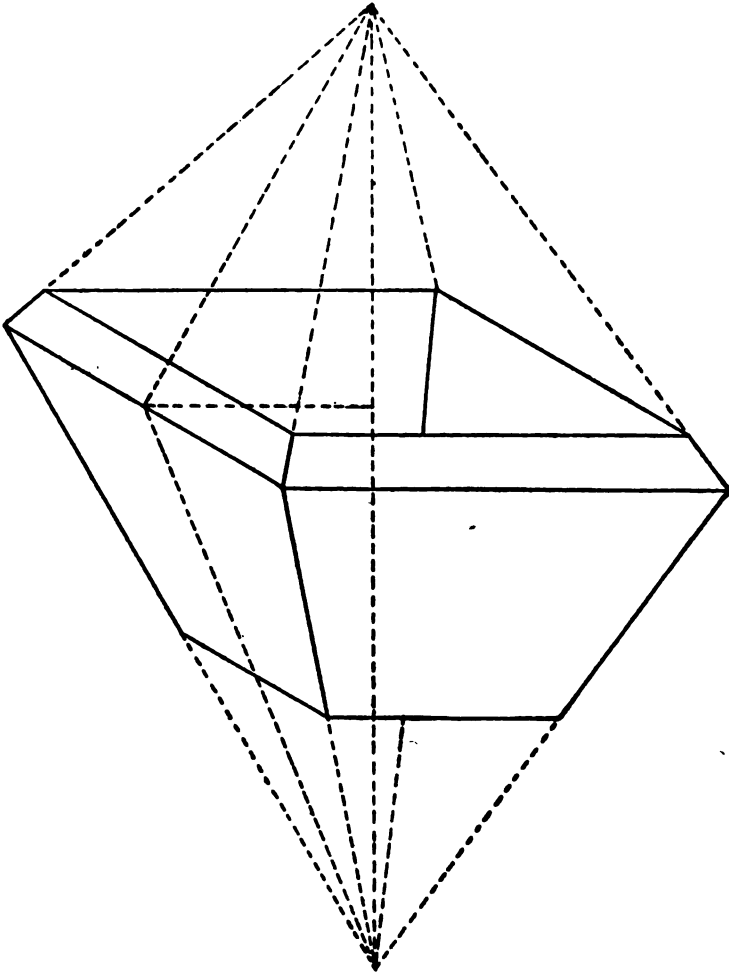

FIG. 80

of the square, and this applies to any run or flare given the hopper. The preceding illustrations apply only to the square cornered hopper, but the rule therein used applies to any regular polygonal hopper. For example we will take the pentagon or five sided hopper, and in this we will show two methods of obtaining the miter bevel.

First method is shown in Fig. 82. We wish to make a hopper two-thirds pitch or 16-inch



FIG. 81

rise to the foot in run; 12 and 16 give the hypotenuse or pitch and is 20 inches in length. Next we take 8 and 17-24 on the blade because that is the tangent for the pentagon just the same as 12 is for the square figure. Then with 8 and 17-24 for radius describe an arc from 12 cutting the pitch line as shown; thence carry this point to the blade as at A; 12 on the tongue and A on the blade will give the miter across the edge of the board; the latter giving the cut. 8 and 17-24

In this illustration we show two squares with their tongues together. The side cut is found the same as in the former figure, but in this another pitch is shown and which we will call the co-pitch. This pitch stands at 90 degrees from the given pitch of the hopper, provided the timber is square edged or at right angles with the side (though it may be at any angle). The rule is: Take the length of the co-pitch on the blade and 8 and 17-24 on the tongue and the latter will give the miter. This rule applies to any polygonal hopper. The figures to use on the tongue are always 12 and those that give the miter for a polygonal frame.

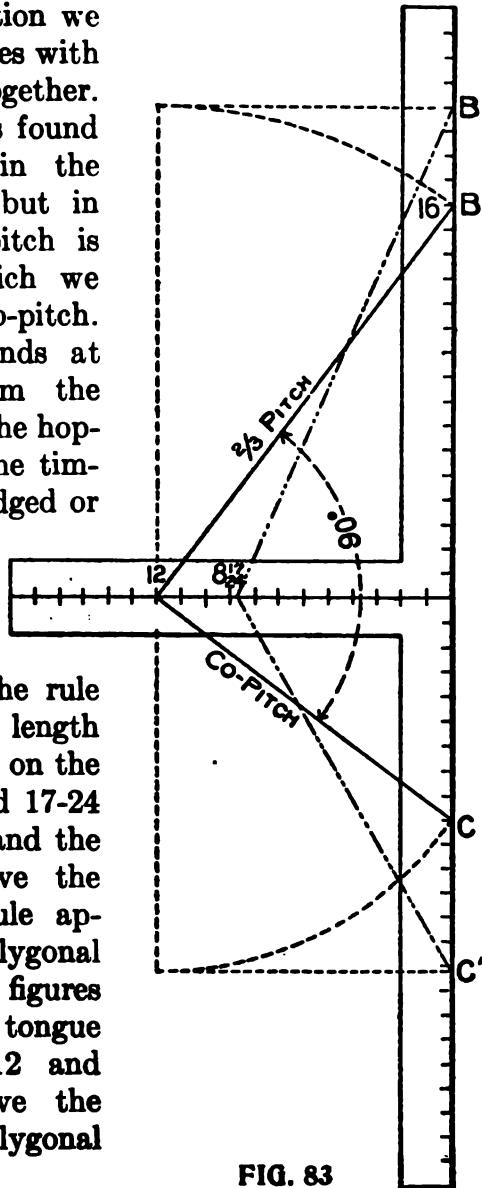

FIG. 83

In the case of a square hopper the tangent is equal the run (12) and for that reason only one set of figures on the tongue is used.

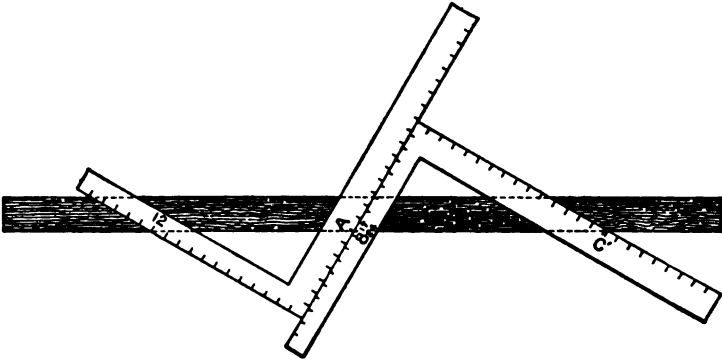

FIG. 84

In Fig. 84 is shown a proof of the two methods. The blade giving the cut in the former and the tongue in the latter.

Trusses.—In taking up the subject of trusses it is not our intention to enter into the subject further than the application of the Steel Square in obtaining the cuts and bevels. The rules for finding the cuts and bevels for common rafters and braces will apply to truss work in general.

In Fig. 85, A is the straining beam, B the brace, T the tie beam. Generally the brace has about one-third the length of tie beam for a run. From the rise and run find the length and lower end bevel of the brace. After marking the lower end bevel on the stick, add to it just what is cut out of the tie beam. The bevel of the upper end

of the brace where it butts against the straining beam is found in the following manner: Take the length of the brace, or a proportional part, and mark it on the edge of a board; take half the rise of the brace on the tongue, lay it to one of these marks on the board, and move the blade

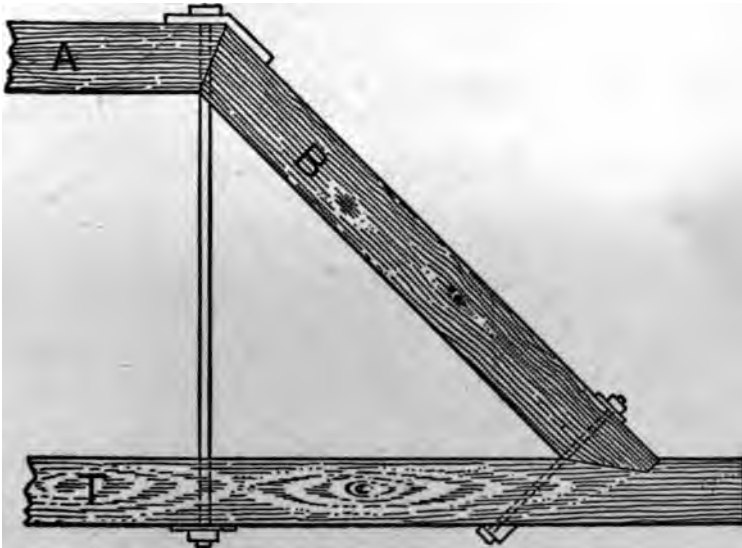

FIG. 85

until it touches the other mark on the board. A line drawn along the tongue gives the bevel for both brace and straining beam. The angle made between brace and straining beam is thus bisected: Lay off the measurements from the outsides of the timbers. Put a bolt where shown, with a washer under the head to fit the angle of straining beam and brace.

Fig. 86 represents the cross braces between the straining and tie beams. If the braces butt together as shown in the upper left hand corner of figure, the length and cuts are simply those for a common rafter having the same run and

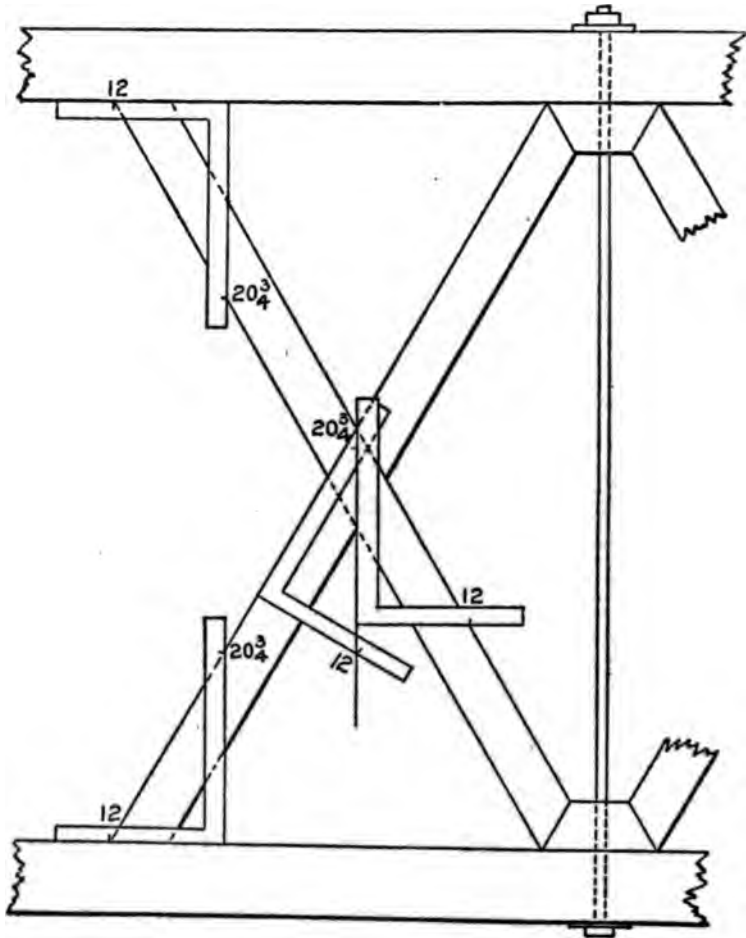

FIG. 86

rise. Usually a block of hard wood is used for the ends of the braces to rest against, as shown at the upper right hand corner, and in that case the angle may be found as for the brace against the beam.

These braces are sometimes halved at the center to allow the sides of the braces to be flush with each other. The angle of cut is found by applying the square with the figures that give the plumb cut of a rafter of same pitch; and to this without change of figures apply a second square as shown; this will give the proper angle across the brace from which to remove the wood.

Tower for Windmill, etc.—In connection with trusses we show in Fig. 87 a tower suitable for a windmill or for other similar purposes. The posts incline two inches to the foot—that is, two inches from the plumb line to every foot in the length of the post, and this incline is both ways. The length of post and bevels at the foot and top of posts may be found by applying the square as shown at R—that is, 24 inches on the blade and 4 inches on the tongue or 2 inches on the tongue and 12 inches on the blade, which is the same thing, so far as the bevels are concerned. These same figures also answer for the ends of the joists, S-S. We show in Fig. 88 the manner in which the bevels at the foot of the posts are marked. The dotted lines show the bevels on all sides, for, as the post leans two ways, the post must be beveled two ways. This, of course, will present itself to the workman as

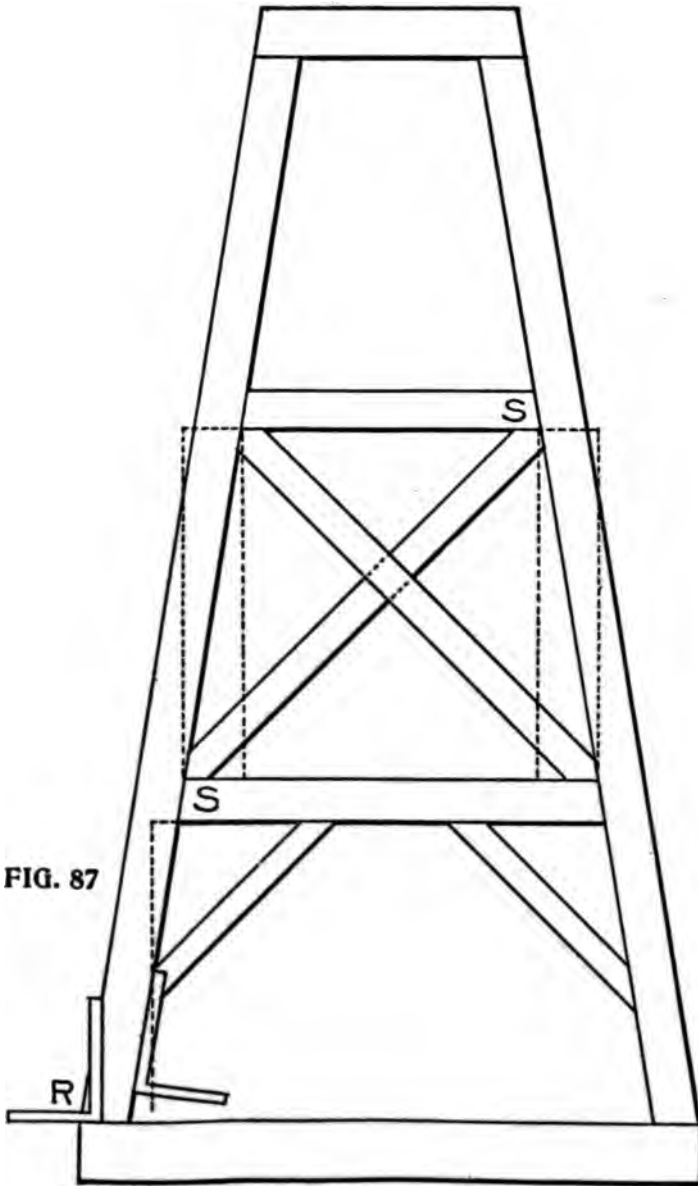

FIG. 87

he proceeds. Let us suppose the foot of the post to have no tenon, but it is intended to rest flat-footed on the sills. This being the case, it gives us an opportunity of getting the backing of the post, for, like a hip rafter—which it is—it requires to be backed, if it is intended to be enclosed or boarded, and we will suppose it is so intended. From an examination of Fig. 89 we can see how

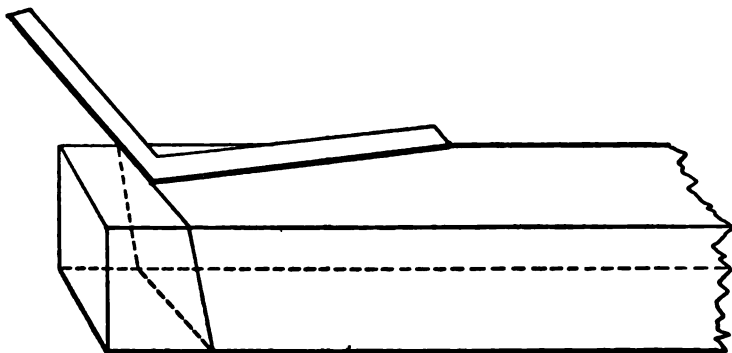

FIG. 88

the backing of the post may be obtained by using the square and applying it on the foot after it has been cut. The overwood at E is to be removed. In order to make the ends of the braces and cross pieces cut square against the corner posts, the latter should also be backed on the inside angle as well as on the outside, otherwise there would be little angle across the top of these braces to contend with, not much it is true, but enough to leave an open joint unless these pieces are cut to the angle. It will be noticed that the square is placed on the angles O and P, with

its heel at E. The distance from E to P is the same as from E to O. The overwood shown in this is somewhat exaggerated purposely, to give a clear idea of the requirements. The braces shown in this sketch will give the student an opportunity to figure. The lengths and bevels

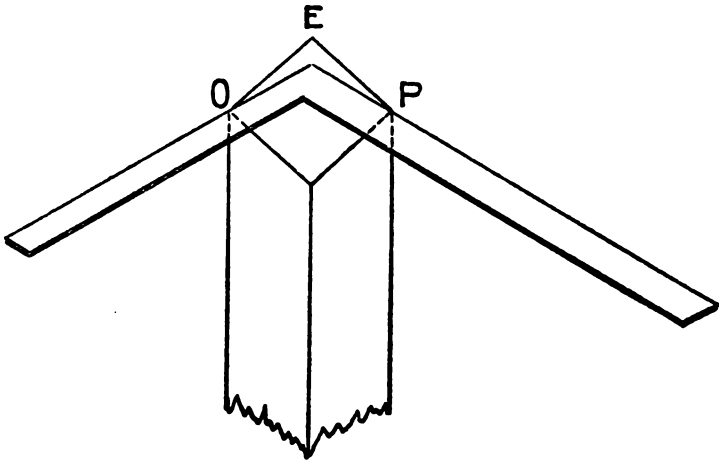

FIG. 89

may be obtained either by using the square or by taking them from a drawing, or by calculation.

We may observe at this point, that the posts in this structure are simply like the hips in a very steep roof or spire, and in a measure may be treated as such, but it will be seen that while the posts rest in the same position as the hip in the roof, its sides do not rest parallel with the plate as they do in the case of the tower.

Part VII

STAIR BUILDING

How to Determine the Height and Run—Illustrations of the Pitch-Board—Open Strings—Risers and Treads—Housed or Closed Stairs—Other Methods of Making a Stair String—Connecting and Affixing Strings—Balusters—Brackets—Finish of Wall String at Foot of Stairs—Finish of Wall String at Top of Stairs—Open String at Foot of Stairs

Although an entire volume can be devoted to the structure and kinds of stairs we will only dwell upon them so far as the Steel Square is concerned in obtaining the run and rise.

How to Determine the Height and Run.—In laying out stairs with the square, it is necessary to first determine the height from the top of the floor from which the stairs start, to the floor on which they are to land; also the run or distance of their horizontal stretch. This is found by dividing the height into the number of rises desired in the stairway. This usually results in fractions of an inch to each rise and somewhat complicates the work. However, the fractions may be avoided by the use of the story pole by spacing it off with a pair of compasses into the number of risers desired in the stairs. This being done the rest is comparatively easy, because the run or horizontal stretch is not usually limited as to exact space as in the case of the rise of the

stairs, and as there is always one less tread than there are risers its length is determined by the width given the treads. Thus if there are 14 risers in the stairs there would be 13 treads. If the treads be 9 inches wide the run would be 9 times 13 or 117 inches, which is 9 feet and 9 inches as shown in Fig. 90. From this it will be seen that the run and rise of the individual step is taken on the Steel Square as shown in the illustration, and determines the shape of the pitch-board.

The way to make a pitchboard is by the use of a steel square, which, of course, every carpenter



FIG. 91

in this country is supposed to possess. Fig. 91 shows a part of a stair string with the square laid on, showing its application in cutting out a pitch-board. As the square is placed it shows 10 inches for the tread and 7 inches for the rise.

To cut a pitch-board, after the tread and rise have been determined, proceed as follows: Take

a piece of thin, clear stuff, and lay the square on the face edge, as shown in the figure, and mark out the pitch-board with a sharp knife; then cut out with a fine saw and dress to knife marks, nail a piece on the largest edge of the pitch-board for a fence, and it is ready for use.

Illustrations of the Pitch-board.—The next thing to be considered is what is the manner of

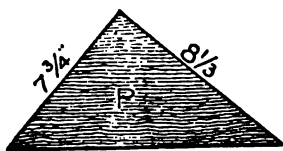

FIG. 92

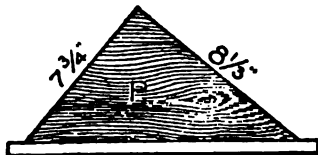

FIG. 93

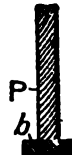

FIG. 94

using the pitch-board? Before showing its use, however, we wish the learner to have a thorough conception of what the pitch-board is, and with that object we show and explain the following illustrations. Fig. 92 shows the pitch-board pure and simple; it may be an inch thick, or if of hard wood, may be from a quarter to a half an inch thick.

Fig. 93 shows the pitch-board after the gauge or fence is nailed on. This fence or gauge may be about one and one-half inches wide, and from $\frac{3}{8}$ to $\frac{1}{2}$ of an inch thick. Fig. 94 shows a sectional view of the pitch-board with the fence nailed on as at bp, which shows the edge of the board.

Manner of Using the Board.—Fig. 95 shows the manner of applying the board. R,R,R,R, is

the string, and the line A shows the jointed or straight edge of the string. The pitch-board, p, is shown in position, the line $8\frac{1}{2}$ represents the step or tread, and the line $7\frac{3}{4}$ shows the line of the riser. These two lines are of course at right angles, or as the carpenter would say, "they are square." This string shows five complete cuts for treads, and six complete cuts for risers. The bottom of the string at W is cut off at the line of the floor on which it is supposed to



FIG. 95

rest. The line C is the line of the first riser. This riser is narrower than any of the other risers, because the thickness of the first tread is always taken off it; thus, if the tread is $1\frac{1}{2}$ inches thick, the riser in this case would only require to be $6\frac{1}{4}$ inches wide, as $6\frac{1}{4}$ and $1\frac{1}{2}$ inches together make $7\frac{3}{4}$ inches. Another thing to be considered is the string, which must be cut so that the line at W will be only $6\frac{1}{4}$ inches from the line at $8\frac{1}{2}$, and it must be parallel with it. The first riser and tread having been satisfactorily dealt with, the rest may be easily marked off by simply sliding the pitch-board along the line A until the line $8\frac{1}{2}$ on the pitch-board strikes the line $7\frac{3}{4}$ on the

string, when another tread and another riser are marked off in the same manner.

Open Strings.—Fig. 96 shows a portion of the stairs in position. S, S, shows the strings, which in this case are cut square; that is, the part of the string to which the riser is joined is cut square across, and the “butt” or end wood of the riser is seen. In this case, also, the end of the tread is cut square off and flush with the string and riser. Both strings in this instance are open strings.

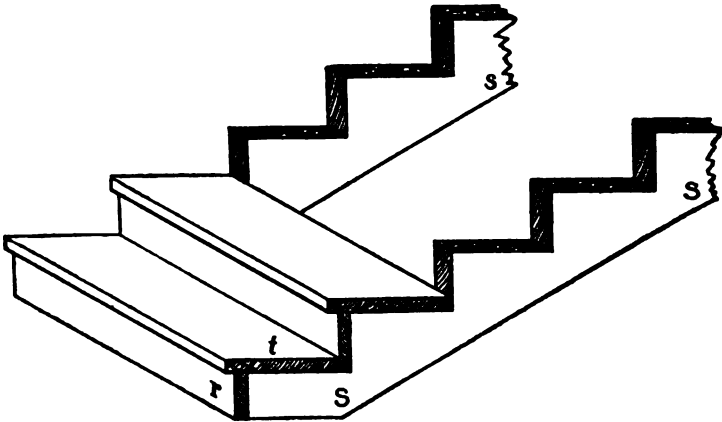

FIG. 96

Usually in stairs of this kind, the ends of the treads are rounded off similar to the front of the tread, and the ends project over the strings the same distance that the front edge projects over the riser. If a moulding or “cove” is used under the nosing in front, it should be carried round on the string to the back edge of the tread, and cut off square, for in this case the back edge of the

tread will be square. The riser is shown at R, and it will be noticed that it runs down behind the tread on the back edge, and is either nailed or screwed to the tread.

Risers and Treads.—Fig. 97 shows the customary way of putting risers and treads together.

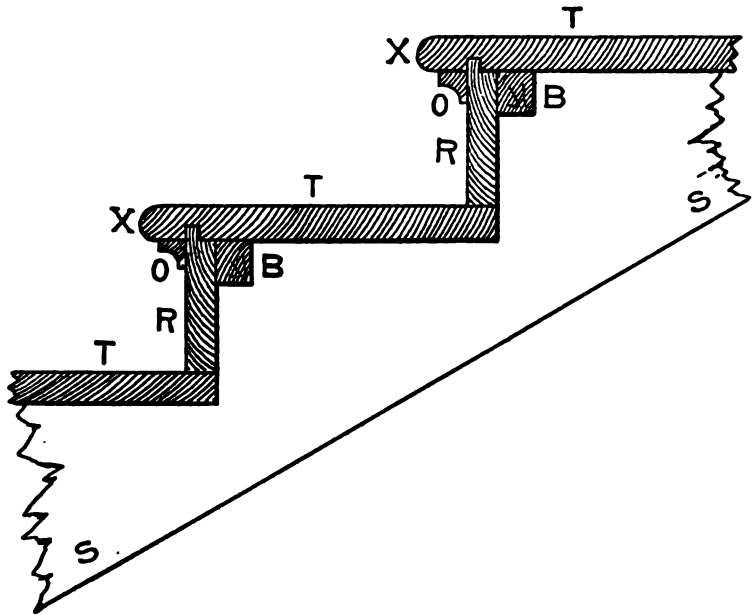

FIG. 97

T, T shows the treads, R, R the risers, S, S the string; O, O the cove moulding under the nosing X, X. B, B shows the blocks that hold the tread and risers together. These blocks should be from four to six inches long, and made of very dry wood. Their section may be from one to two inches square. On a tread three feet long,

three of these blocks should be used at about equal distances apart, putting the two outside ones about six inches from the strings. They are glued in the angle.

It will be noticed that the riser has a lip on the upper edge, which enters into a groove in the tread. This lip is generally about $\frac{3}{8}$ inches

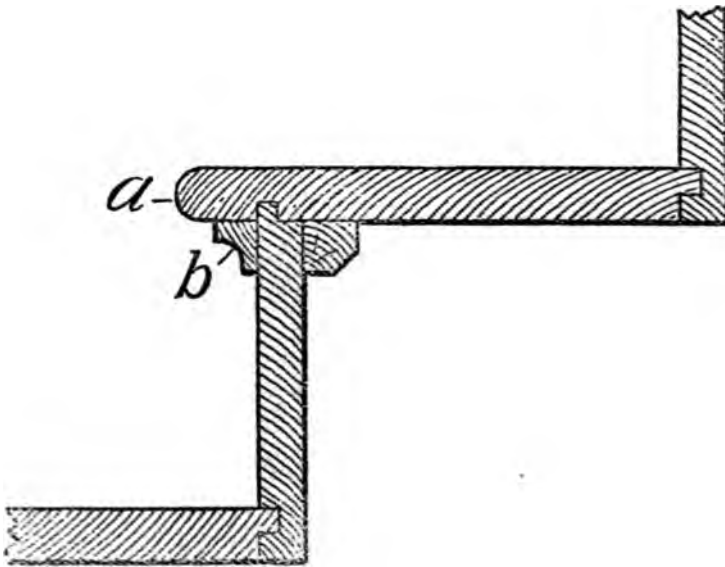

FIG. 98

long, and may be $\frac{3}{8}$ or $\frac{1}{2}$ of an inch in thickness. Care must be taken in getting out the risers, that they are not made too narrow, as allowance must be made for the lip. If the riser is a little too wide it will do no harm, as the overwidth may hang down below the tread; but it must be made the exact width where it rests on the string.

The treads must be made the exact width required before they are grooved or the nosing worked on the outer edge. The lip or tongue on the riser should fit snug in the groove and bottom. By following these last instructions, and seeing that the blocks are well glued in, a good solid job will be the result.

In Fig. 98 a scheme for the construction of the tread and riser is shown. The tread has a lip worked on it at the back edge, which enters a groove ploughed in the riser. The riser also has a lip left on the upper edge, which goes into a groove made in the tread similar to the method shown in Fig. 97.

The cove is shown at b, and the angle block is also represented. This makes a very solid step when well put together, and, where the steps are to be of the better kind, this method of constructing the step may be adopted with advantage. This method is a favorite one with stair builders, and has proved to be a substantial one, though it costs a little more than the ordinary method.

Housed or Closed Strings.—Fig. 99 represents a housed or closed string. In this the risers and treads are let into the strings from the back side.

Gauge lightly a line from the upper edge of the string, the distance intended to stand above the treads as shown in the dotted line. On this line apply the pitch-board, as explained on previous pages. In laying out housed strings, it is as well to take the fence off the pitch-board, as it can be handled better without it, as the long

side will have to be kept close to the gauge line, to insure good work. The top lines for treads and the face lines for risers, are the lines that define the step, and cannot be changed; but the back line of the riser and the lower line of the tread should be made to run so that the housing or

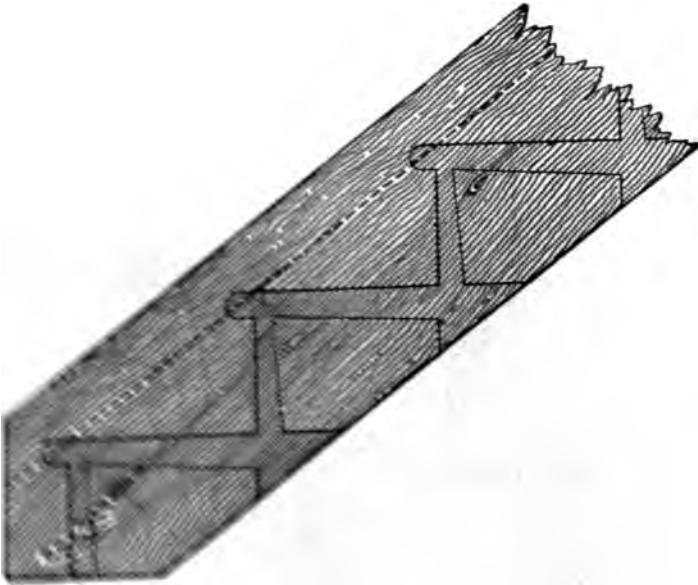

FIG. 99

groove will be wider at the under side of the string than at the junction of the riser and tread at the housing, where the grooves will be the same width as the riser and tread are in thickness separately. The housing projects over the riser, as will be seen, and to mark this portion out, it is usual to make

a template or pattern for the purpose. Indeed, it is best to make a template to lay out the whole housing of the tread, and in shape as the shaded part shown in the illustration.

The reason the grooves are left wider at the back edge of tread is so that a wedge can be driven between the tread and the lower edge of the groove,

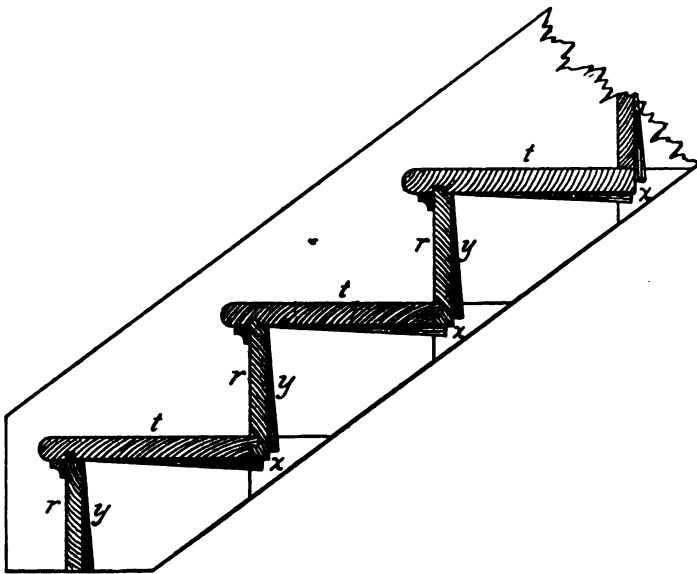

FIG. 100

to force the top side of the tread close to the upper edge of the groove, thus making a tight joint and insuring strength and rigidity to the whole structure. The risers are also wedged into place, as is shown in Fig. 100. After the treads and risers are laid out on the string, a sharp pointed knife blade should be used to mark the lines for the

face of the riser and top of the tread, then a fine tenon saw should be used to saw down to the exact depth. This will not be difficult to perform when the hole forming the nosing recess has been bored to the proper depth. A gauge line should be made on the back edge of the string to indicate the depth of the housing. Care should be taken in removing the wood from the grooves, that too much is not taken or the grooves made too deep. A gauge for trying the depth may be made out of a piece of hard wood, say about four inches long and three inches wide, by about one-half inch in thickness. Make a tenon on the center of one end, about three-quarters of an inch in width, and cut the shoulders back sufficiently to admit the tenon being long enough to touch the bottom of the groove or housing, when the shoulders rest on the face of the string.

In Fig. 100 we show a sectional elevation through the steps. The treads, *t, t*, and the risers, *r, r*, are shown in position. These are secured, as will be seen, by means of the wedges, *x, x*, and *y, y*, which are well covered with glue before they are inserted and driven home. Stairs made after this manner are strong and perfectly solid under foot.

Other Methods of Making a Stair String.—We have now shown you the way to make an open string and how to make a housed string. There are several other methods of making a stair string than those shown already; one way is to form two tenons on the end of the tread, which fit

into mortises cut through the string. This method makes a very strong stair if the string is wide enough to allow for the loss of strength caused by making the mortises.

In Fig. 101 several ways of forming an open string are shown. Different methods of uniting the risers and treads are shown. They may be

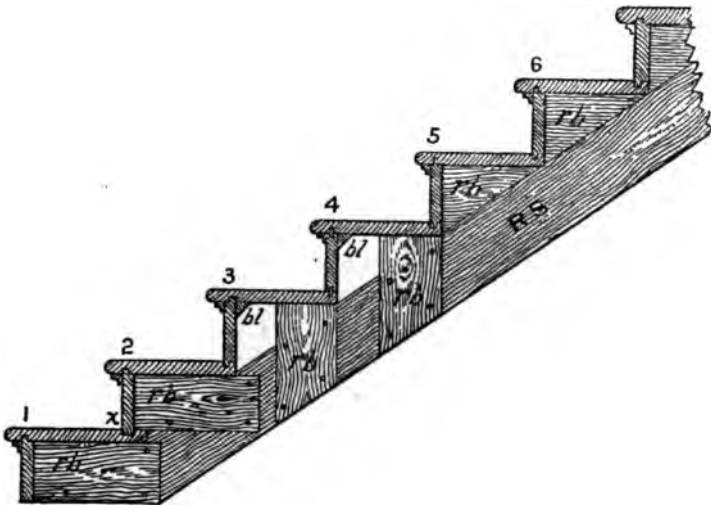

FIG. 101

grooved and tongued, as in steps 5 and 6, or feathered as in step 4, or rabbeted as as step 3; in every case the joint should be glued and blocked. Sometimes the riser is housed into the tread as at X. The tread is also sometimes tongued into the riser, but this is not good construction, and should be avoided. R, S, show a rough string or scantling, having pieces, r, b, steps 2, 3 and 4, nailed or screwed onto it to support the treads.

Triangular pieces may be nailed on the top edge of the scantling to support the treads, as shown at steps 5 and 6. A rough string, corresponding to the open string, may be used in place of any of the foregoing methods. The under edge of all rough strings should be made to coincide with the lower edge of the furring or cleat, nailed on the inside lower edge of the outside cut string, and so arranged that the lathing will nail on the furring, the rough strings, and the lower edge of the wall string.

Connecting and Affixing Strings.—We have now described several methods of dealing with strings, but there still are several other things connected with strings, both housed and open, that will be necessary to explain before one can proceed to put up a fair flight of stairs. The connection of the wall string to the base of the lower and upper floors, and the manner of affixing the outer or cut string to the upper joist and to the newel are matters that must not be overlooked, and we intend to show how these things are accomplished. We will proceed now to describe the method of finishing the tread and riser at the end of the step that rests on the outer string.

Fig. 102 gives two views of a portion of a better-class stair, a stair with cut and mitered string, or open string stair. In referring to the plan W S, shows the wall string; RS the rough string placed there to give the structure strength; and OS the outer or cut string. At a, a the ends of the risers are shown, and it will be noticed that

they are mitered against the vertical or riser line of the string, thus preventing the end wood of the riser from being seen. The other end of the riser is in the housing in the wall string. The

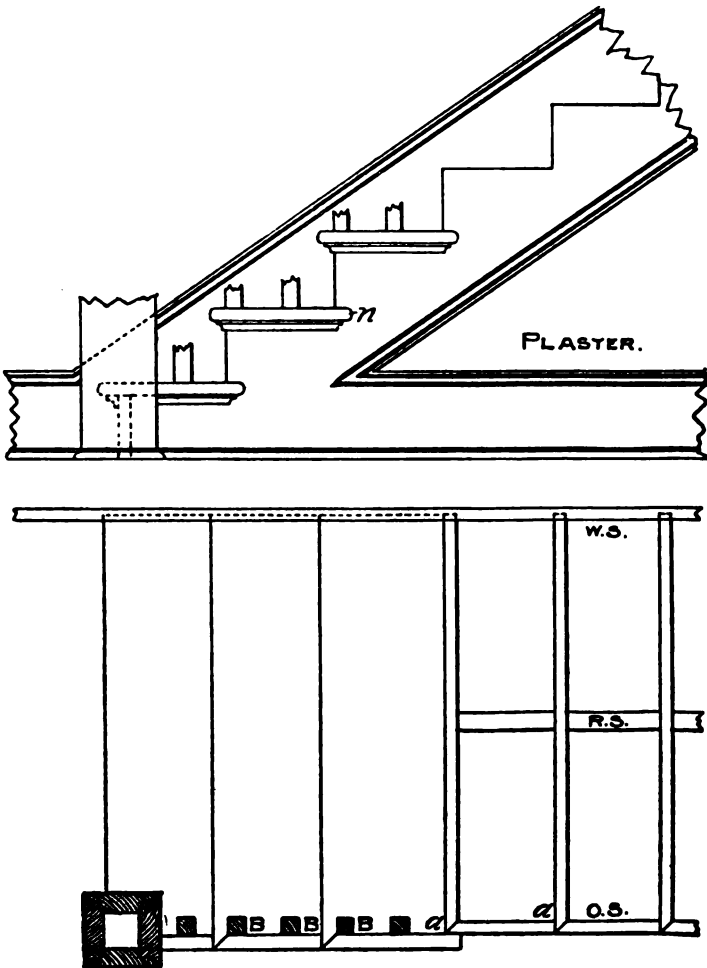

FIG. 102

Finish of Wall String at Foot of Stairs.—Fig. 104 shows the manner in which a wall string is finished at the foot of the stairs. S shows the string, with a moulding wrought on the upper edge. This moulding may be a simple ogee, or may consist of a number of members, or may be left plain; the edge of the string may be left quite plain; this will be regulated in a great meas-

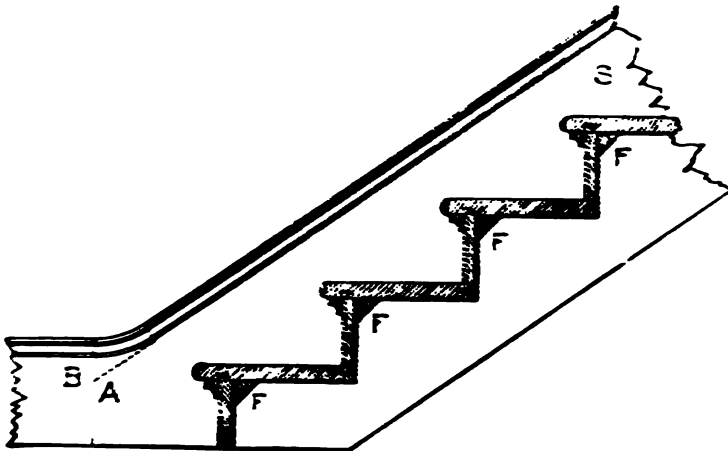

FIG. 104

ure by the style of finish in the hall, or wherever the stairs are placed. B shows a portion of the baseboard, the top edge of which has the same finish as the top edge of the string. B and A together show the junction of the string and base. The dotted line shows when a piece of stuff has been glued onto the string to make it wide enough at the junction to get the ease-off or curve. F,

F shows the blocks glued in the angle of the steps to make them firm and solid.

Finish of Wall String at Top of Stairs.—Fig. 105 shows the manner in which the wall string S is finished at the top of the stairs. It will be noticed that the moulding is worked round the ease-off at A to suit the width of the base at B. The string is cut over the floor horizontally

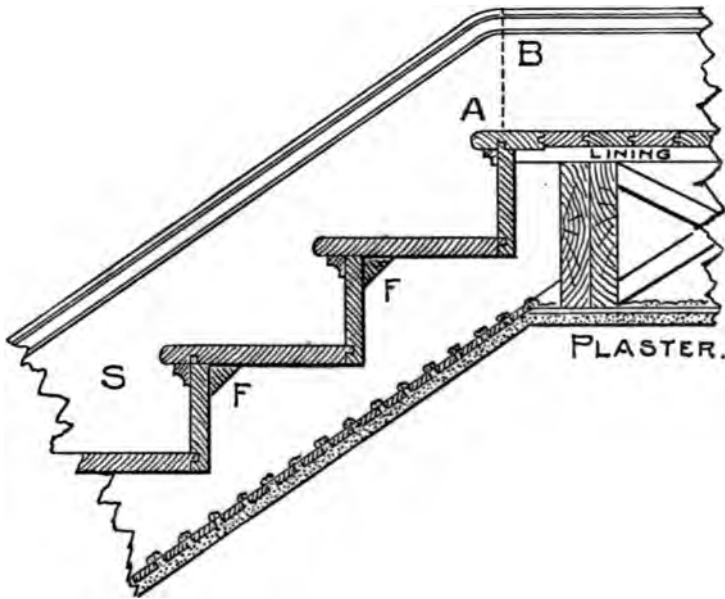

FIG. 105

and vertically or plumb against the joists. The plaster line under the stairs and on the ceiling is also shown.

Open String at Foot of Stairs.—Fig. 106 shows the cut or open string at the foot of the stairs, and

the manner of dealing with it at its juncture with the newel post K. The point of the string should be mortised into the newel two, three or four inches, as shown by the dotted lines, and the mortise made in the newel should be made near the center, so that the center of the baluster will be directly opposite the central line of the newel post. The proper way to manage this is to meas-

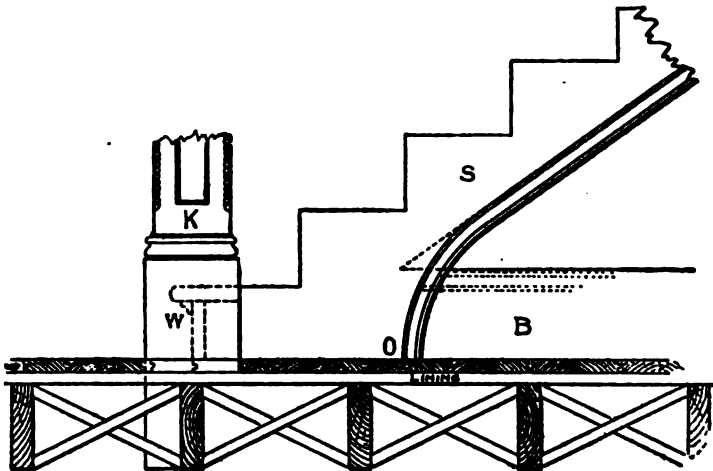

FIG. 106

ure the central line of the baluster on the tread, and then make this line correspond with the central line of the newel post. By a careful attendance to this matter, much trouble will be avoided where a turned cap is used to receive the lower part of the rail. The lower riser, in a stair of this kind, will be something shorter than the ones that follow it, as it must be cut between the

newel and the wall string. A portion of the tread, as well as the riser, will also butt against the newel, as shown at W. If there is no spandril or wall under the open string, it may run down to the floor, as shown at O. The piece O is glued onto the string, and the moulding is worked on the curve.

If there is a wall under the string S, then the base B, shown by the dotted lines, will finish against the strings, and it should have a moulding stuck on its upper edge the same as the one on the lower edge of the string, if any, and this moulding should miter into the one on the string. When there is a base, the piece O is dispensed with.

The square of the newel should run down by the side of a joist, as shown, and be firmly secured to it by iron knees or other suitable devices. If the joist runs the other way, try and get the newel post against it, if possible, either by furring out the joist or cutting a portion off the thickness of the newel. The solidity of a stair, and the firmness of the rail, depend very much on the rigidity of the newel post.

Fig. 107 shows how the cut string is finished at the top of the stairs. This illustration requires no explanation after the foregoing has been examined.

So far we have dealt with those stairs having a bevel at the bottom only; however, there are many modifications of straight and return stairs, that have either two, four or six newels. When

any of those conditions arise, the treatment of strings at their finishing points will necessarily be somewhat different than that described, but the general principles, as shown and explained,

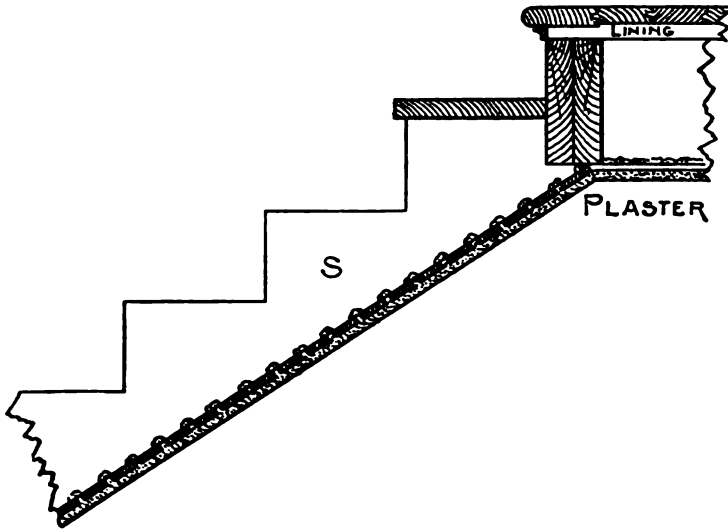

FIG. 107

will hold good. As this work is only intended to cover the simpler class of stair building, we will not enter into the more complicated phase of the work.

Miter Boxes.—One of the most troublesome things the carpenter meets with is the cutting of a spring moulding when the horizontal portion has to miter with a gable or raking moulding. Undoubtedly the best way to make good work of these mouldings is to use a miter-box. To do this make the down cuts B, B (Fig. 108) the

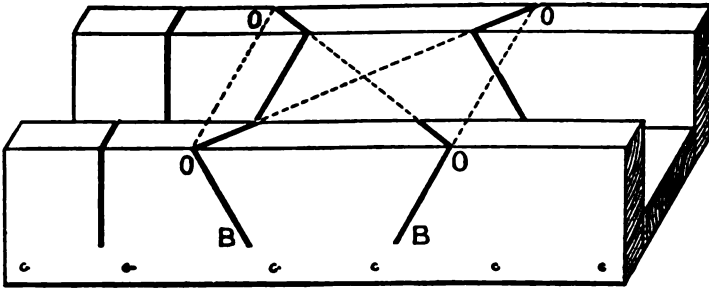

FIG. 108

same pitch as the plumb cut on the rake. The over cuts O, O, O, O, should be obtained as follows: Suppose the roof to be a quarter pitch—though the rule works for any pitch when followed as here laid out—we set up one foot of the rafter, as at Fig. 109, raising it up 6 inches, which gives it an

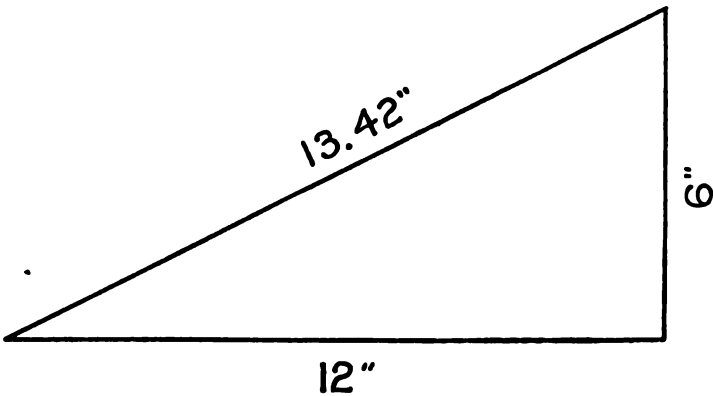

FIG. 109

inclination of quarter pitch; then the diagonal will be nearly $13\frac{1}{2}$ inches. Now draw a right-angled triangle whose two sides forming the

right angle, measure respectively 12 and $13\frac{1}{2}$ inches as shown in Fig. 110.

The lines A and B show the top of the miter box with the lines marked on. The side

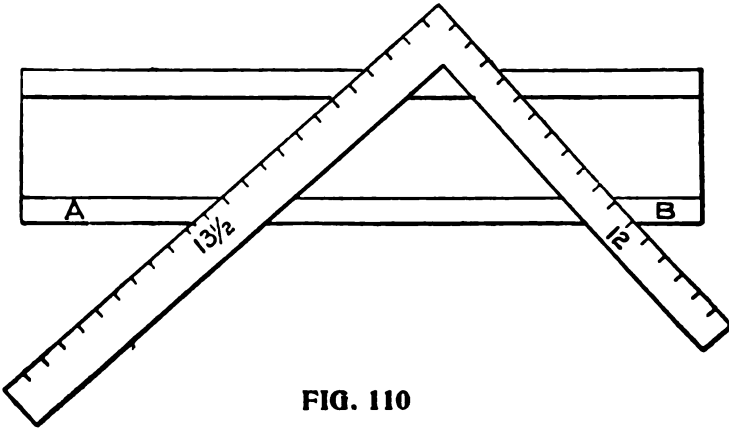

FIG. 110

marked $13\frac{1}{2}$ inches is the side to mark from; this must be borne in mind, and it must be remembered that this bevel must be used for both cuts, the 12-inch side not being used at all.

Another excellent method for obtaining the section of a raking mould that will intersect a given horizontal moulding, is given below, also the manner of finding the cuts for a miter box for same. The principles on which the method is based being, first, that similar points on the rake and horizontal parts of a cornice are equally distant from vertical planes represented by the walls of a building; and, second, that such similar points are equally distant from the plane of the roof. Representing the wall faces of a building

by the line DB (Fig. 111), and a section of the horizontal cornice by DBabcdef, Bab being the angle of the roof pitch; draw lines aa'', cc'', ff'', parallel to DB and intersecting the line ka'', which is drawn at right angles to DB through

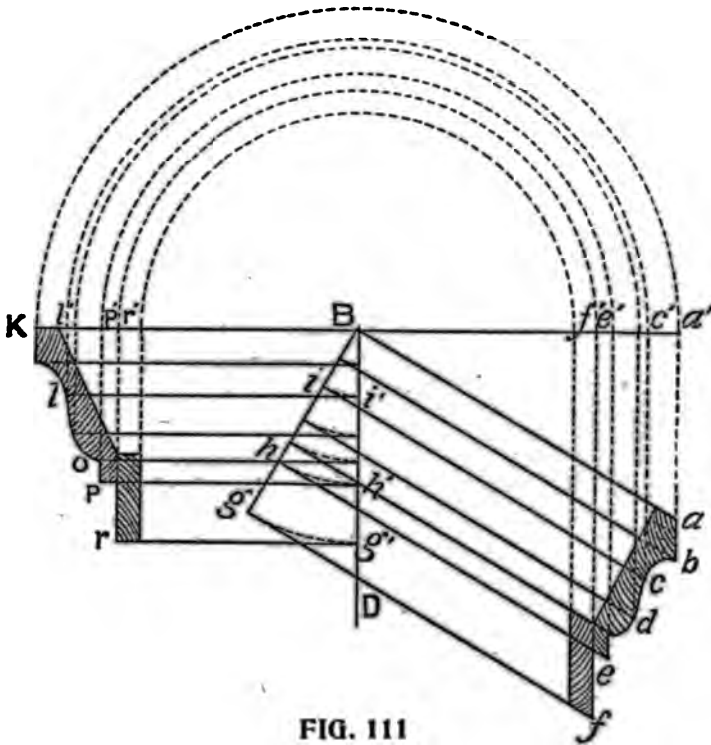

FIG. 111

the point B; then, with B as a centre, describe the arcs a''k, c''l, etc., intersecting the same line ka'' on the opposite side of DB; after which extend lines from the points r''l''k, parallel to DB. This gives the point k at the same distance

from DB as the points a and a'' , and the line l'' at the same distance as cc'' . The rest of the same group of parallel lines are found to be similarly situated with respect to DB.

From Descriptive Geometry we have the principle, that if we have given two intersecting lines contained in a plane, we know the position of that plane: hence we may represent the plane of a roof by the line Ba and Bk (Figs. 111 and 112): and since it will be most convenient to measure the distances required in a direction

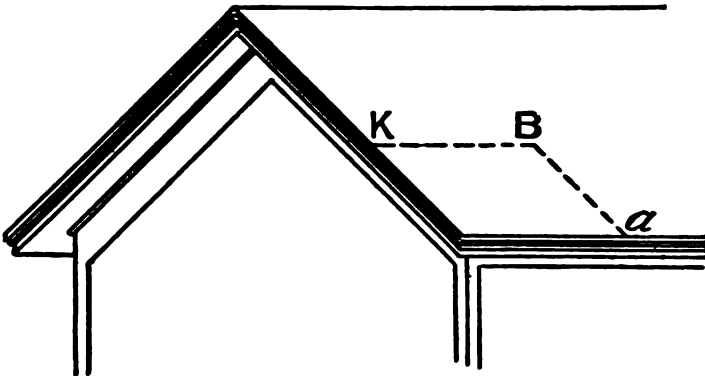

FIG. 112

perpendicular to that plane, in following out the principle draw lines from the points cef , etc., parallel to Ba and intersecting the line Bg, which is made perpendicular to Ba. This gives us on Bg the perpendicular distance of the points cef , etc., from the line Ba. From the intersections of these lines with Bg, and with B as a center, describe arcs intersecting the line DB at i'' , h'' ,

g'' , etc.; from these intersections with DB draw lines $i''l$, $h''p$, $g''r$, etc., parallel to Bk, until they intersect the first group of lines drawn from the same point on the horizontal section which will give the similar point of the rake section. Taking the point l, for example, we have, as before proved, l at the same distance from DB as c, and i being at the same distance from Ba as c, Bi being equal to Bi'' , and Bi'' equal to l'' , l'' is equal to Bi'' , and consequently, l is the same distance from Bk as c is from Ba, which is in accordance with principle already shown. The intersection of each set of lines being found and

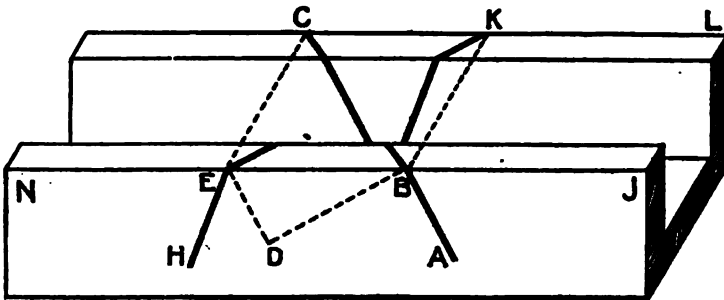

FIG. 113

marked by a point, the contour of the moulding may be sketched in, and the rake moulding, of which the section is thus found, will intersect the given horizontal moulding, if proper care has been taken in executing the diagram.

Fig. 113 shows how to find the miter cut for the rake moulding, the cut for the horizontal one being the same as for any ordinary moulding.

Take an ordinary plain miter box, *NJL*, and draw the line *AB*, making the angle *ABJ* equal to the pitch angle of the roof. Draw *BD* perpendicular to *AB*, and extend lines from *B* and *E* square across the box to *K* and *C*; join *BC* and *EK*. *ABC* will be the miter cut for two of the rake angles; *HEK* will be the cut for the other two angles, the angle *HEN* being equal to the angle *ABJ*. In mitering, both horizontal and rake moulding, that part of the moulding which is vertical when in its place on the cornice, must be placed against the side of the box.



Part VIII

COMBINATION SQUARES

Universal Square—Hight's Union Combination Square—Ideal Bevel
Try-Square—Topp's Framing Tool

The ordinary Steel Square, fully treated of in the first part of this work, is, as has been clearly demonstrated, a constructive tool of wonderful possibilities in the hands of the skillful workman. The labor-saving tables and scales stamped upon the blade and tongue, as we have seen, furnish the workman with an ever-ready solution to almost any problem that may arise in roof framing or in laying out hoppers and hopper bevels.

But modern requirements have demanded even a more effective tool than this. Success in the builder's art to-day depends not so much upon the skill of the artisan as upon the superior quality of the tools he works with. Ingenious inventors, availing themselves of this fact, have placed at the disposal of American workmen certain improved forms of the Steel Square, with various time and labor-saving devices attached. These perfected tools are commonly known as "Combination Squares." Some of them do more than furnish the workman with a constructive tool of the highest excellence, seeming literally to give him brains and an in-

creased number of hands, correspondingly enhancing the quality and quantity of his work.

Every workman, therefore, who uses the Steel



FIG. 113A

Square, should be informed as to the latest types of these time and labor-saving tools. Descriptions of the more important of them, together

with the inventors' directions for their use, are here given.

Universal Square.—This tool is shown in Fig. 113a. It is a combination square for the use of carpenters and other mechanics, and can be used as a try-square, bevel square, pitch-cut square, hip and valley-cut square, and miter square. To operate, you simply reverse it from side to side.



FOR SALE BY
THE RADFORD ARCHITECTURAL CO.
185 JACKSON BOULEVARD
CHICAGO, ILL.

FIG. 113B

It marks $\frac{1}{8}'$ on one side, and $\frac{1}{4}'$ on the other. It takes the place of many tools, and is always ready for any use, there being nothing to adjust or change about it.

Hight's Union Combination Square.—This is the name given to the tool illustrated in Fig. 113b. All the combinations of this tool are available at

the same time. The notches in the edge of the slot in the blade are $\frac{1}{8}$ of an inch apart, and are to enable it to be conveniently used as a gauge. To use the bevel, loosen the clamping bolt, draw the protractor out to the angle required, and clamp in place. Set the protractor by the scale marked on the circular segment. This scale is marked to indicate the angle expressed in inches rise for twelve inches base, when set on the figure 6, in the first series. The angle is one which will give rise of six inches in twelve, or the angle for the bottom of rafter $\frac{1}{4}$ pitch. Set on the 6 in the second series and you have the angle for the top of the rafter for the same pitch. So with all the figures in the first two series. The first series is from 1 to 12, the second from 12 to 1. The third series is for convenience, when it is not convenient to turn the tool over to get reverse angle. The circular segment is laid off in degrees on the lower side, which will readily show you the figures on a square with 12 required to cut any desired number of degrees. The notch in the end of the protractor will enable the tool to be used for a gauge to get in corners, guaging for setting hinges and beveling edges, etc.

Ideal Bevel Try-Square.—This tool, shown in Fig. 113c, is a combination of a bevel and a try-square. The inventor of the tool claims that by using it a carpenter can accomplish more than ordinarily in laying off work. (1) He can mark the square and bevel cut with one continuous stroke of pencil without having to change square.

(2) It is easy to change the bevel blade to any angle, as the slot in the bevel blade will allow shifting so it will always come to corner of square blade. (3) By setting bevel at right angle to

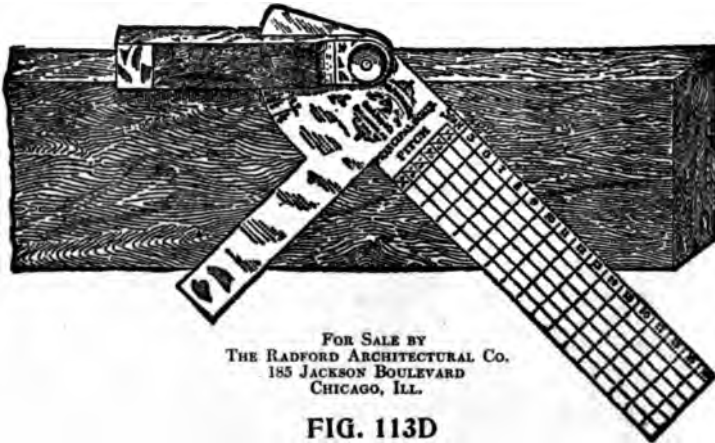

FIG. 113C

Try Square blade, both marks can be obtained without changing the position of square. (4) For beveling a board on edge, swing bevel blade over

to back of handle, which gives a straight surface on handle. (5) When bevel blade is not needed, close same in handle, and you then have a regular Try Square. (6) The Try Square blade is graded in eighths, and the figures are stamped very plain. All parts, it is claimed, are made of the best steel, except the handle, which is of a composition metal that will not rust.

Topp's Framing Tool.—Is a very ingenious combination square, consisting of a T square, a try



square, and a bevel square. It gives all the cuts for different pitches on all kinds of rafters, and the lengths of same, for any plan. Fig. 113d shows the manner in which this tool is used when marking out rafters.

Part IX

KEY TO STEEL SQUARE

The Rafter Table—Lengths and Cuts for One-third Pitch—Side Cut of Jack—Side Cut of Octagon Jack—Side Cut of Hip or Valley—Table of Tangents—To Find Miter for any Regular Polygon—To Draw a Five-Pointed Star—To Frame Timbers at any Degree of Pitch—The Curve for an Octagon Hip—To Find Shape of Jack—To Find Backing for a Curved Hip

The Subject of Degrees and the part they play in Carpentry and Joinery has been overlooked by the woodworkers in general. Every carpenter should understand the divisions of the circle called degrees and the relation they have to the steel square. When this is understood, it is just as easy to frame a roof for any kind of angled building, giving all of the cuts and bevels, as it is for the square cornered building. The same rule applies to all without the aid of any other instrument than the common steel square. How to apply the Steel Square is well explained in the little device recently placed on the market and known as the "Key to the Steel Square," by A. W. Woods, of which the following pages are a brief description.

The above title is the name given to a new framing device, and is meeting with popular favor among carpenters and builders throughout the

country. It is of celluloid, three inches in diameter, on either side of which is pivoted at the center a disk, one side giving the lengths and cuts for the common rafter, having a rise from 1 to 24 inches to the foot, also the corresponding lengths, cuts, and bevels for the octagon hip or valley, and for the hip or valley resting on the right angled corner, while on the other side is given the seat and plumb cuts for rafters and braces having a rise from 1 degree to 90 degrees. It also gives the length of sides and miter cuts for all regular polygons, or the framing of timbers at any degree, and shows how to apply the steel square to obtain the cuts.

The Rafter Table.—Fig. 114 illustrates the side containing the rafter table; it is divided into twenty-four sections, radiating to a common center. These sections represent from 1 to 24 inches rise to the foot in run. The first figures represent the rise, and the three following sets of decimal numbers represent the lengths in inches of the common rafter, octagonal hip and the common hip or valley rafter respectively. The heavy-faced fractional numbers designate the pitch or proportion of the rise of the roof to a foot run, while just beneath the fractional numbers is given the same value in decimal fractions to the one-hundredth part of an inch. The latter is placed here for convenience in finding the near equivalent in common fractions for the decimal part of an inch.

The Revolving Disk contains the title and

abbreviated instructions. By turning the disk until the slot rests opposite the pitch desired, only the lengths and cuts for that pitch will be exposed, thereby preventing errors.

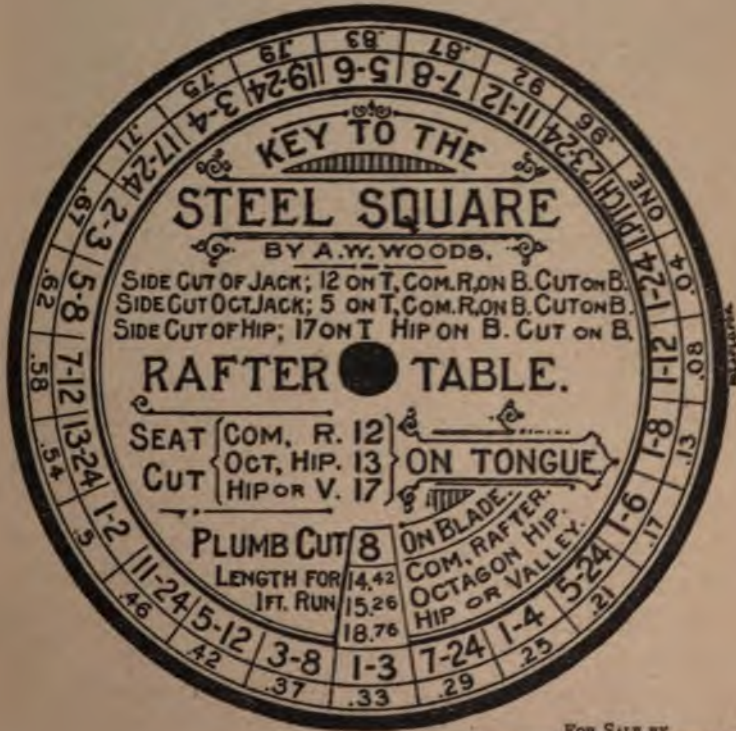

FIG. 114

FOR SALE BY
THE RADFORD ARCHITECTURAL CO.
185 JACKSON BOULEVARD
CHICAGO, ILL.

Example: To Find the Lengths and Cuts For the One-Third Pitch.—Operation. Turn the disk until the slot is opposite one-third and you have, as shown in Fig. 114: 12 on the tongue and 8 on the blade. The tongue will give the seat cut

and the blade the plumb cut for the common rafter.

For the Corresponding Octagon Hip and the Common Hip or Valley substitute 13 and 17 on the tongue respectively, the tongue always giving the seat cut and the blade the plumb cut. The lengths of the rafters for a one-foot run are found to be 14.42, 15.26, and 18.79 for the common rafter, octagon hip and common hip or valley, respectively. Having the lengths given for one foot in run, it is an easy matter to find the lengths of the rafters for any run in either feet or inches by multiplying the lengths here given by the number of feet or fractions of a foot in the run, and point off as many places in the product as there are decimal figures used in the solution, and reduce to feet and inches. Fractional figures may be avoided in the run by dropping them and finding the length only for the number of feet, and then from the plumb cut measure square out the amount of the fraction, which will give the point for the proper plumb cut.

To Find the Common Difference in the Length of Jacks multiply the length of the common rafter (14.42) by the number of inches in the spacing, and divide by 12. Thus, if the jacks be placed 16 inches on centers, $14.42 \times 16 = 230.72$; divide by 12 = 19 and two-twelfths inches.

To Find the Common Difference for the Octagon Jack multiply 14.42 by 2.4, and the product by the spacing, and divide by 12. Thus: $14.42 \times 2.4 =$

$34.608 \times 16 = 553.728$ divide by $12 = 46$ and one-twelfth inches.

For the Side Cut of the Jack.—Take 12 on the tongue and 14.42 (14 and five-twelfths) on the blade. The blade will give the desired cut.

For the Side Cut of the Octagon Jack.—Take 5 on the tongue (because 5 is practically equal to the side of an octagon when the diameter is one foot) and 14 and five-twelfths on the blade, the blade giving the cut.

The figures that give the side cut of the jacks in either of the above cases will also give the cut across the face of the roof boards to fit in the valley or over the hip. The tongue gives the cut.

For the Side Cut of the Hip or Valley.—Take 17 on the tongue and 18.79 (18 and 19-24) on the blade, the blade giving the cut. Backing of the hip. Take 8 on the tongue and 18.79 on the blade. The tongue will give the required bevel. A quicker way, however, is to set off $\frac{1}{2}$ the thickness of the hip along the line of the seat cut (or a line parallel with it), which will give the gauge point from which to remove the wood to the center of the back of the hip. The backing for the octagon hip is practically one-half of that for a hip resting on a square corner.

Table of Tangents.—Fig. 114a represents the table of tangents.

The figures in the two circles represent the degree. Those in the inner circle represent the tangents, and those in the outer represent the

CONSTRUCTION OF THE STEEL SQUARE

THE STEEL SQUARE IS A TOOL USED IN THE
 TRADE AND CONSTRUCTION OF THE SQUARE THE SQUARE



FIG. 114A FOR SALE BY
 THE RANDOLPH ARCHITECTURAL CO.
 155 JACKSON BOULEVARD
 CHICAGO, ILL.

gives the cut up to 45 degrees, then it reverses to the tongue from 45 degrees to 90 degrees.

Example: To Frame a Roof With 30 Degrees Pitch. Operations: Turn the slot till it rests opposite 30 degrees and you have, as shown in Fig. 114b:

Common Rafter.—Take 12 on the tongue and 6.93 (6 and 11-12) on the blade.

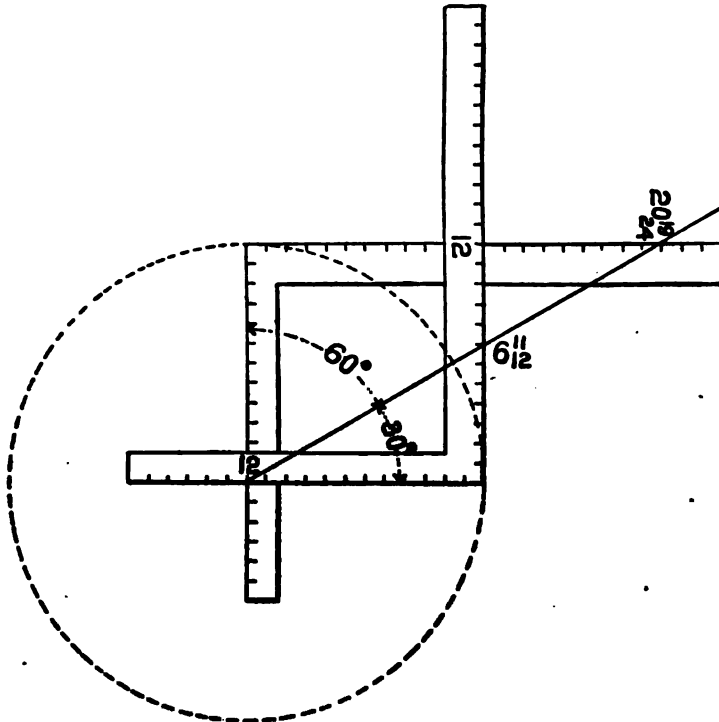

FIG. 114 B

Octagon Hip.—Take 13 on the tongue and 6 and 11-12 on the blade.

Hip or Valley.—Take 17 on the tongue and 6 and 11-12 on the blade. The tongue in either of the above cases gives the seat cut and the blade the plumb cut.

Side Cut of Jack.—Take 12 on the tongue and the diagonal length from 12 to 6 and 11-12 taken

on the blade. The blade will give the cut. Side cut of octagon jack. Take 5 on the tongue and proceed as for the common jack

Side Cut of Hip or Valley.—Take 17 on the

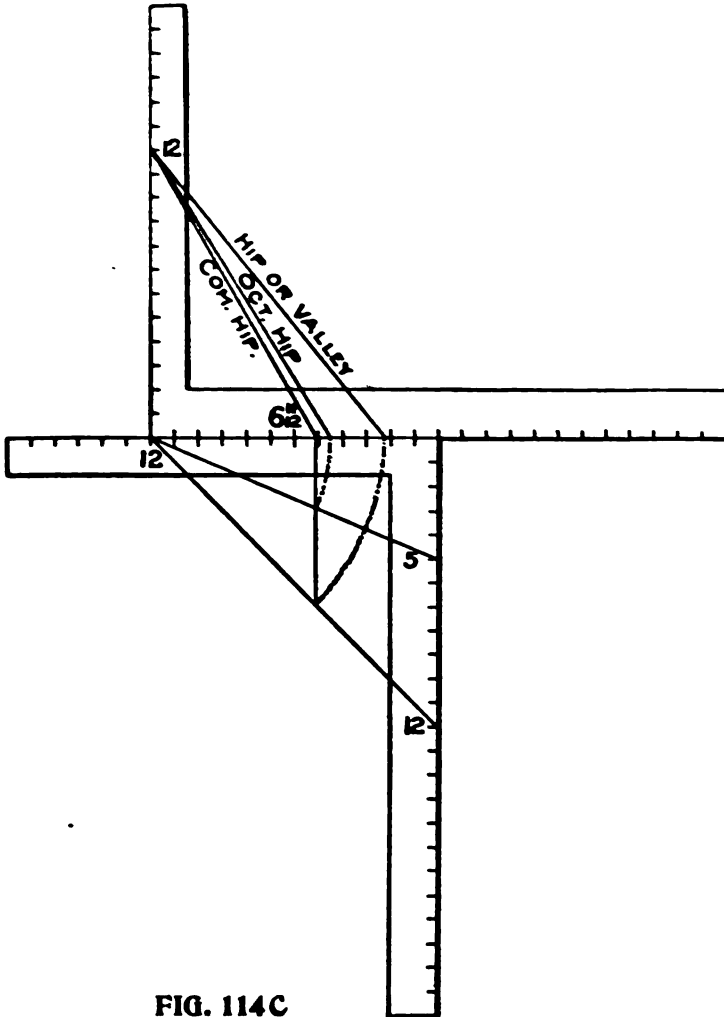

FIG. 114C

tongue and the length from 17 to 6 and 11-12 taken on the blade. The blade will give the cut. If the roof be 60 degrees pitch proceed the same as for the 30 degrees pitch (using the same figures), but the cuts are reversed on the square. However, this only applies to the seat and plumb cuts of the common rafter. The same may be

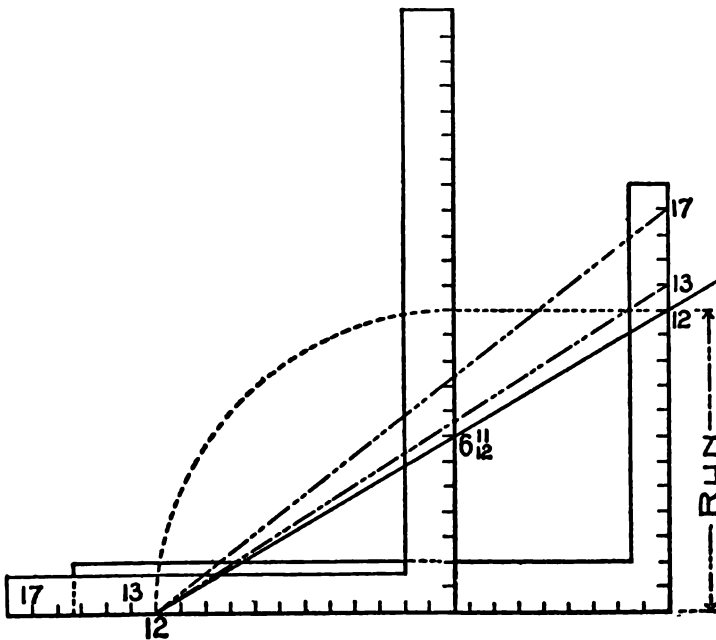

FIG. 114 D

obtained for the hips, as shown in Fig. 114c, but the lengths of the rafters are not so readily obtained as before because what was the run is now the rise. To get the lengths by scale it is necessary to extend the pitch lines till the base

THE

WATER SQUARE

IF ONE OF THE COMMON SIDES MEASURE 12 INCHES, AS SHOWN IN FIG. 115.

TO FIND THE WIDTH FOR ANY REGULAR POLYGON.—
Divide 121 by the number of sides of the polygon.

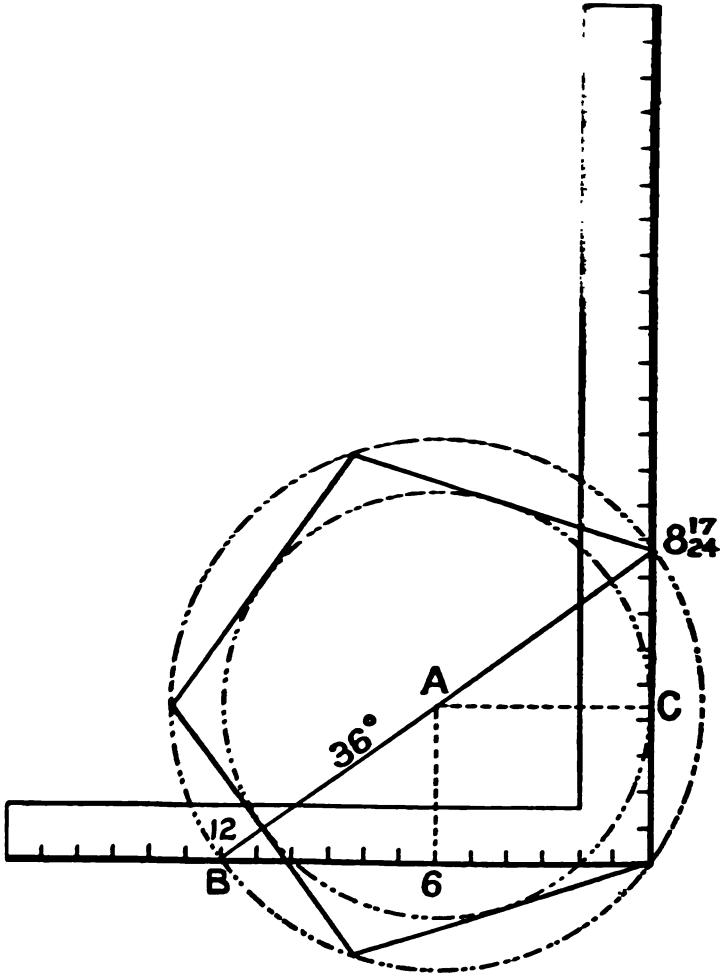

FIG. 115

The quotient will be the degree of the miter. **Example:** Find the miter for a pentagon. 180 degrees divided by 5=36 degrees. Turn the slot to 36 degrees and we have 8.72 (8 and seventeen-twenty-fourths). Take 12 on the tongue and 8 and 17-24 on the blade, the blade giving the miter. The figures on the blade also give the length of the sides of the pentagon when the inscribed diameter is one foot. By squaring up from 6 on the tongue as shown will locate the center at A. A-C is the radius for the inscribed diameter, and A-B the same for the circumscribed diameter.

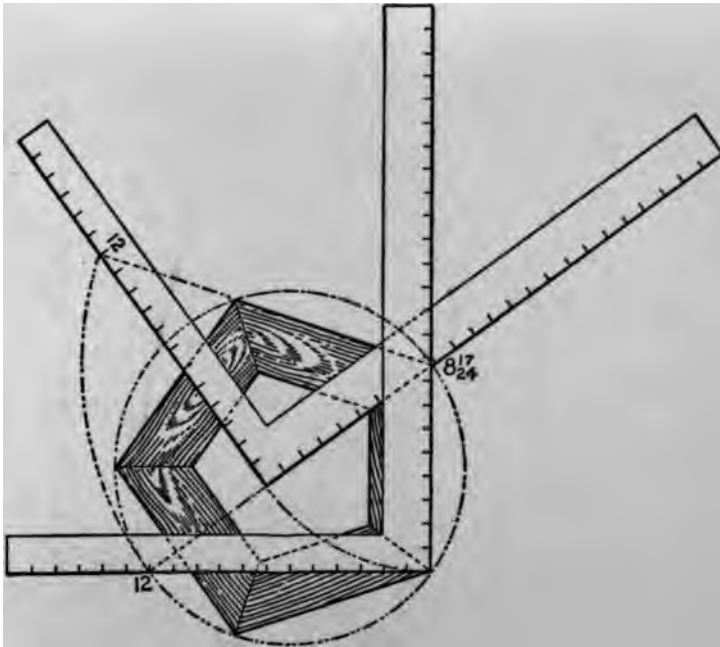

FIG. 115A

If we let 8 and 17-24 act as a pivot as shown in Fig. 115 and swing the blade till it rests along the 36 degree line, it will show as in Fig. 115a. The 12 on the tongue will rest in line with one of the sides of the pentagon and the blade will rest along the line of the miter, thus proving that the latter gives the cut. The figures 8 and 17-24 also represent the length of one of the sides when the inscribed diameter is one foot.

Polygons of any size may be drawn as shown in Fig. 115b. However, it is better to multiply

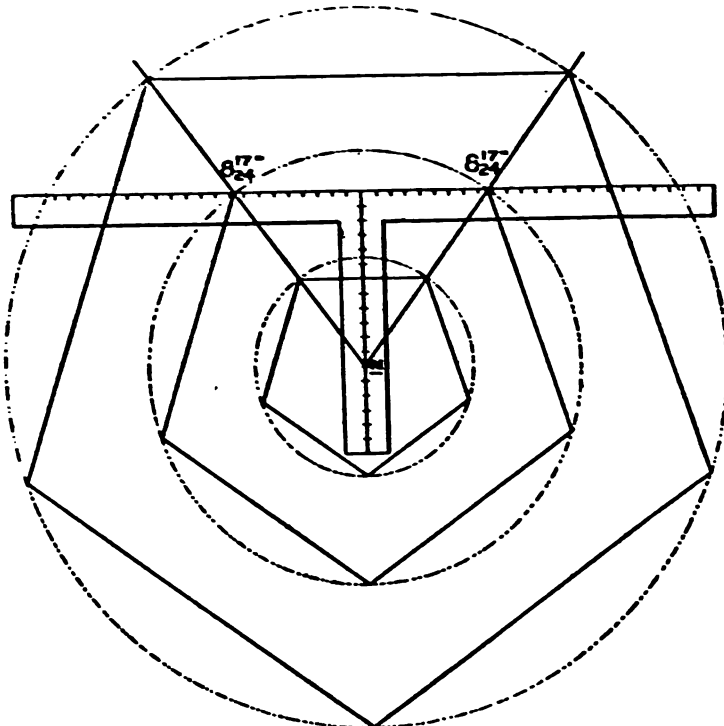

FIG. 115B

the desired diameter by the decimal number given and reduce to feet and inches as follows: Suppose we wish to make a pentagon frame ten feet inscribed diameter, $10 \times 8.72 = 87.20$ inches, or

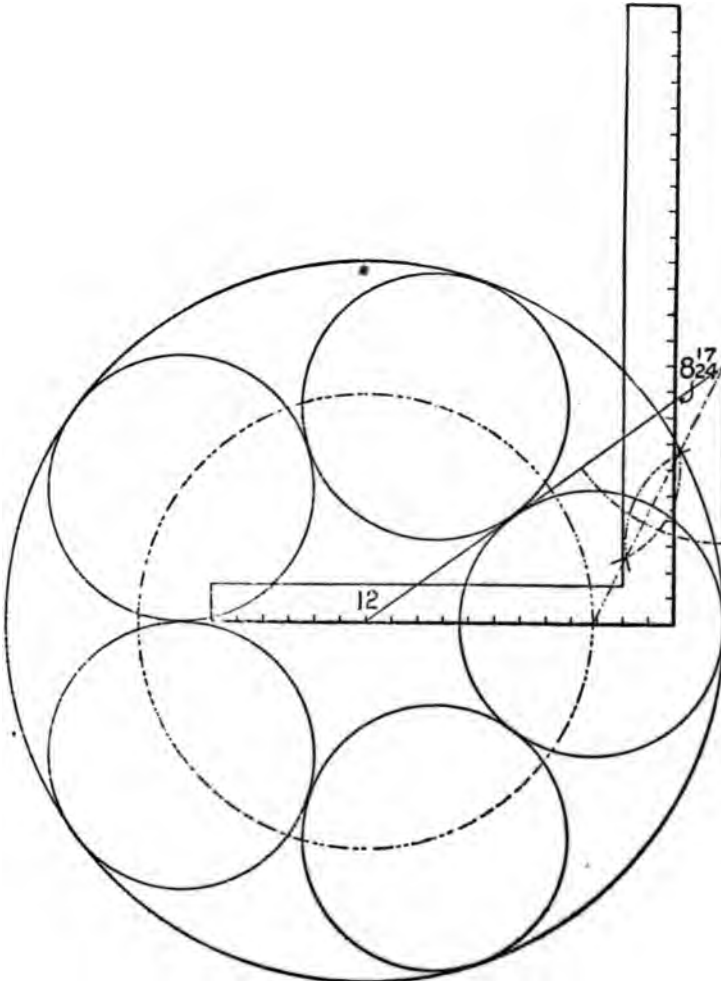

FIG. 115C

7 feet 3 and 5-24 inches will be the length of the sides. If we wish to put five circles inside of a large circle it may be done as shown in Fig. 115c. The given circle may be of any size and the figures used on the steel square are the same as those used in the preceding illustrations. From this it will be seen that it is the degree line that governs the layout of the diagram. If we wish to put four circles inside of a given circle then the degree

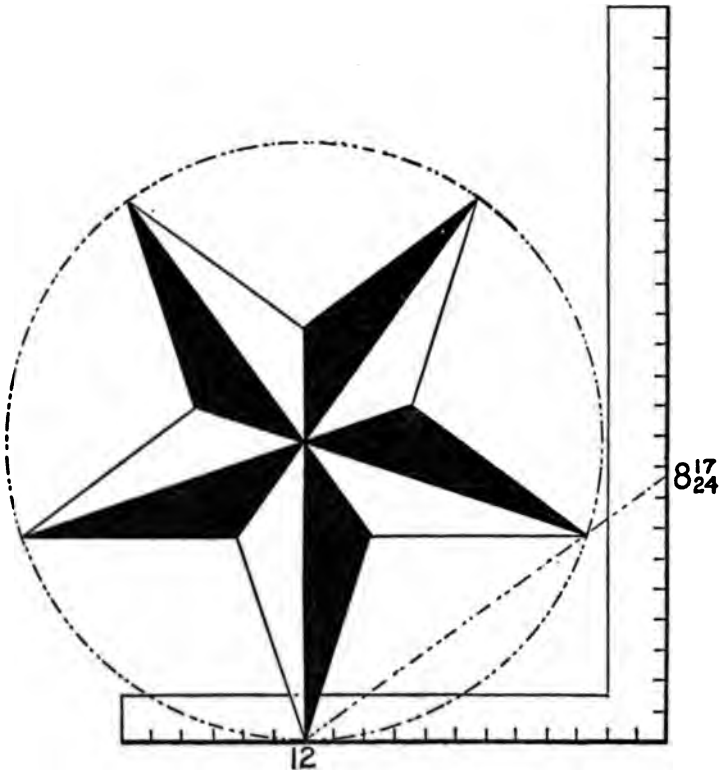

FIG. 116

line would rest at 45 degrees and intersect the blade at 12; or if we wish six circles, the degree line would rest at 30 degrees and the intersection on the blade would be at 6 and 11-12 inches.

If we wish to draw a five pointed star it may be done as shown in Fig. 116, and may be of any size

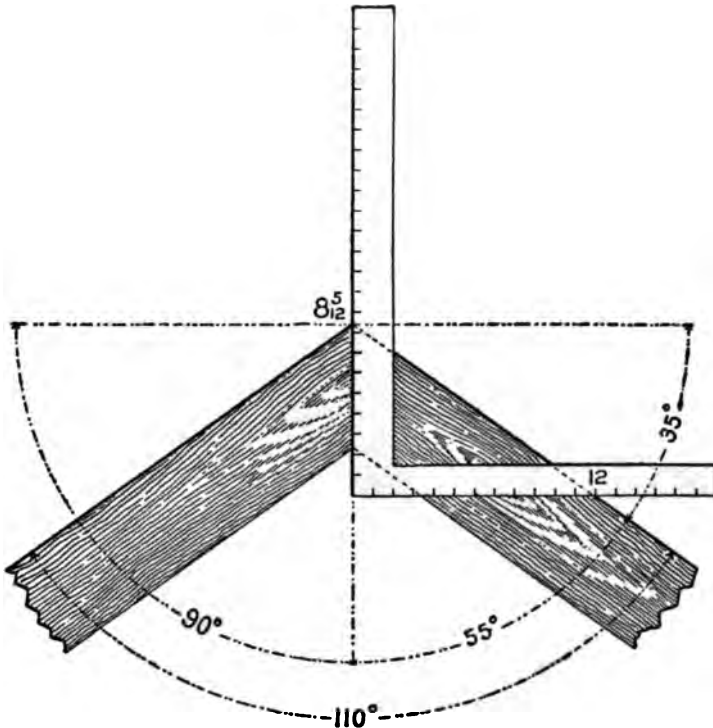

FIG. 116 A

desired by setting off the radius at a point directly above 12 on the tongue, and where the circumference cuts the degree line as from 12 to A will be the proper spacing of the points of the star on the circumference.

To Frame Timbers at Any Degree of Pitch.—Frame two pieces at an angle of 110 degrees. It is evident that the miter should stand at half way between the angle, or at 55 degrees; and 55 degrees from 90 degrees leaves 35 degrees, and we find the tangent for 35 degrees is 8.4 (=8 and 5-12). Therefore, 12 on the tongue and 8 5-12

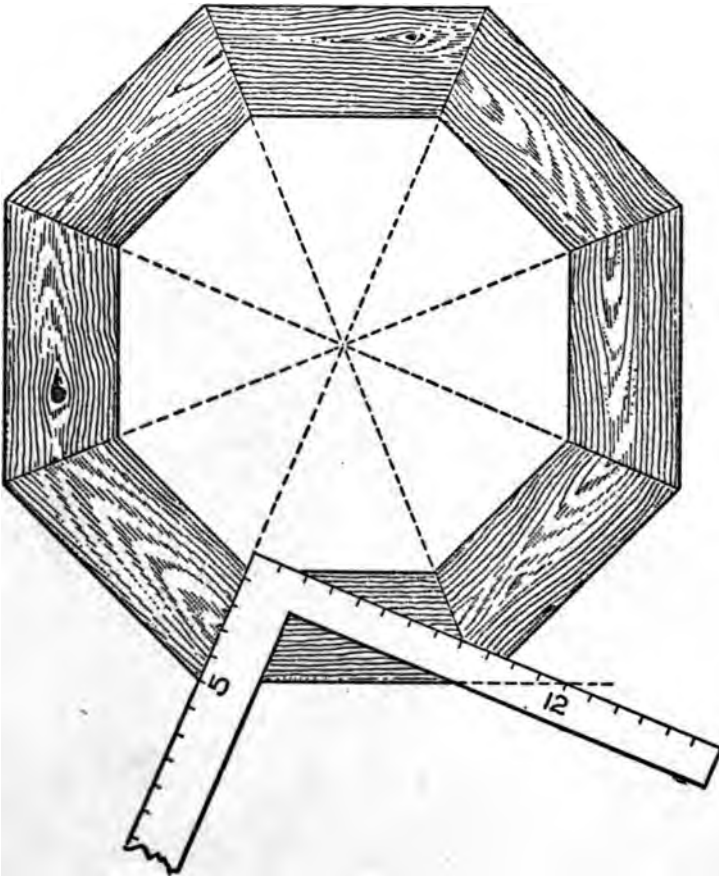

FIG. 116 B

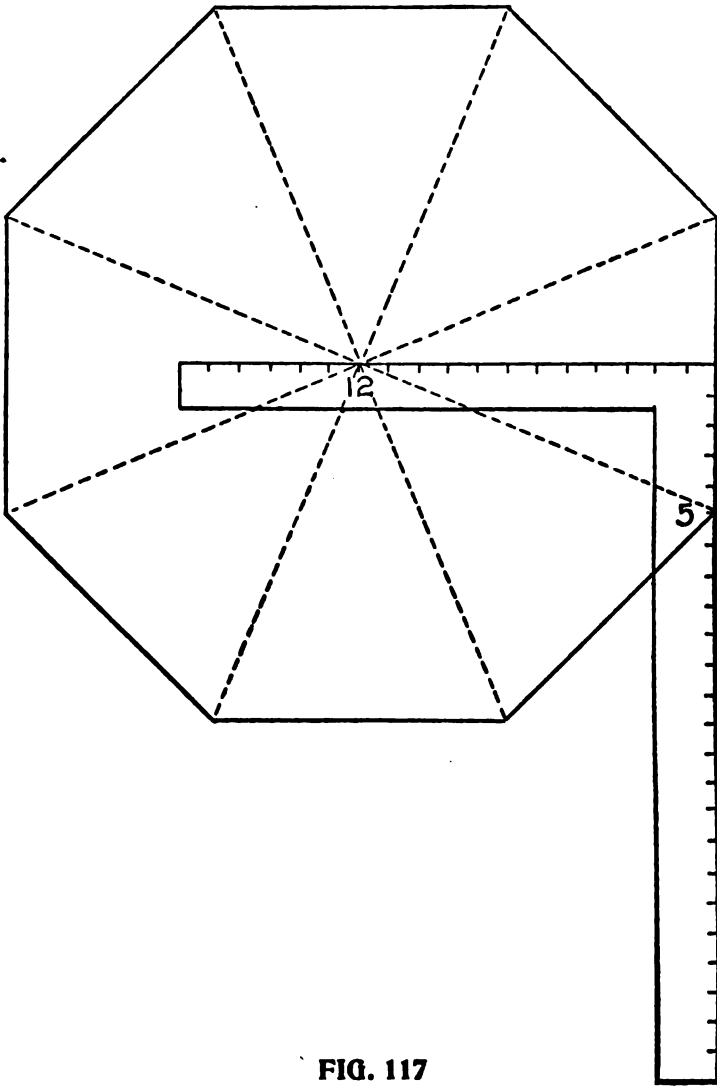

FIG. 117

on the blade will give the miter, the blade giving the cut, as shown in Fig. 116a.

Though it may seem that some of these problems are of but little value on account of the small demand for their use, yet to know how to correctly handle the simpler forms is to know them all. It is true that the carpenter is not often called upon to frame polygonal roofs other than for the square or octagon shape, yet to be able to do so makes him a more finished and competent workman.

The Octagon for an Example.—

With this in view we will take the octagon for an example; we have found that 12 and 5 taken on the tongue and blade of the square give the miter as shown in Fig. 116 B. These figures also form the angle that the hip rests with the common rafter as shown in Fig. 117. They also form the basis for all of the cuts. We also find for the true octagon

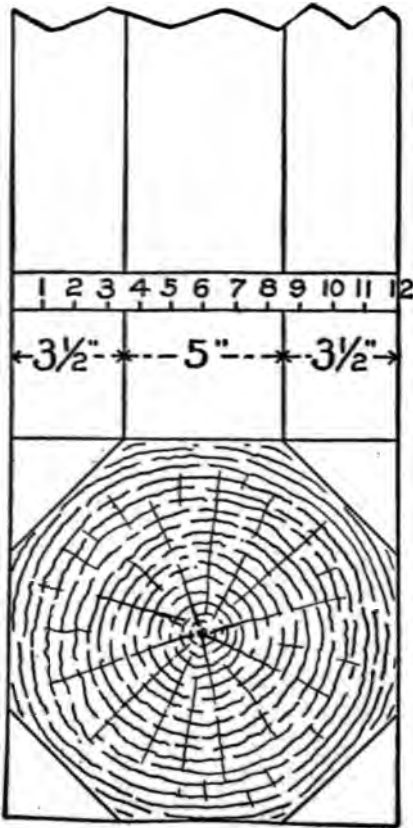

FIG. 117 A

the run of the hip diverges from the tongue 5 inches in a one foot run. Hence the side of an octagon one foot in diameter must be 5 inches at shown in Fig. 117A, or five-twelfths of its diameter. This proportion always exists whether it be inches, feet or yards. Thus the side of an octagon one inch in diameter would be five-twelfths of an inch. A 6-inch diameter would be $6 \times 5 - 12 = 30 - 12$ or $2\frac{1}{2}$ inches, as shown in Fig. 117b.

Again from 12 to 5 measures 13 inches, a gain of one inch to one foot run of the common rafter, therefore the run of an octagon hip is one-twelfth longer than that of the common rafter.

The Curve for an Octagon Hip.—Now let us apply this proportion in developing the curve for an octagon hip.

In Fig. 117c draw BA. Place the square as shown, and draw line AC, and square down from B to C. AB is the run of the common rafter. AC is the run of the hip, and is one-twelfth longer than AB; BC is equal to one-half the length of the plate, and is five-twelfths of the length AB. The whole figure bounded by A, B and C,

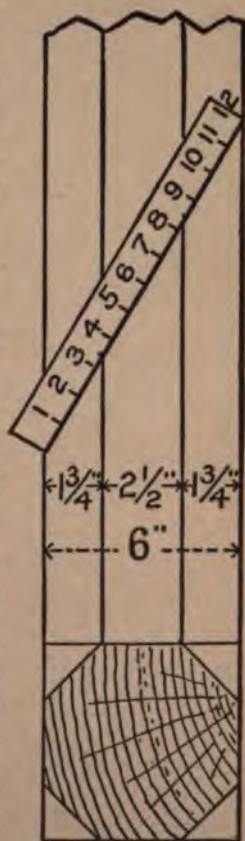
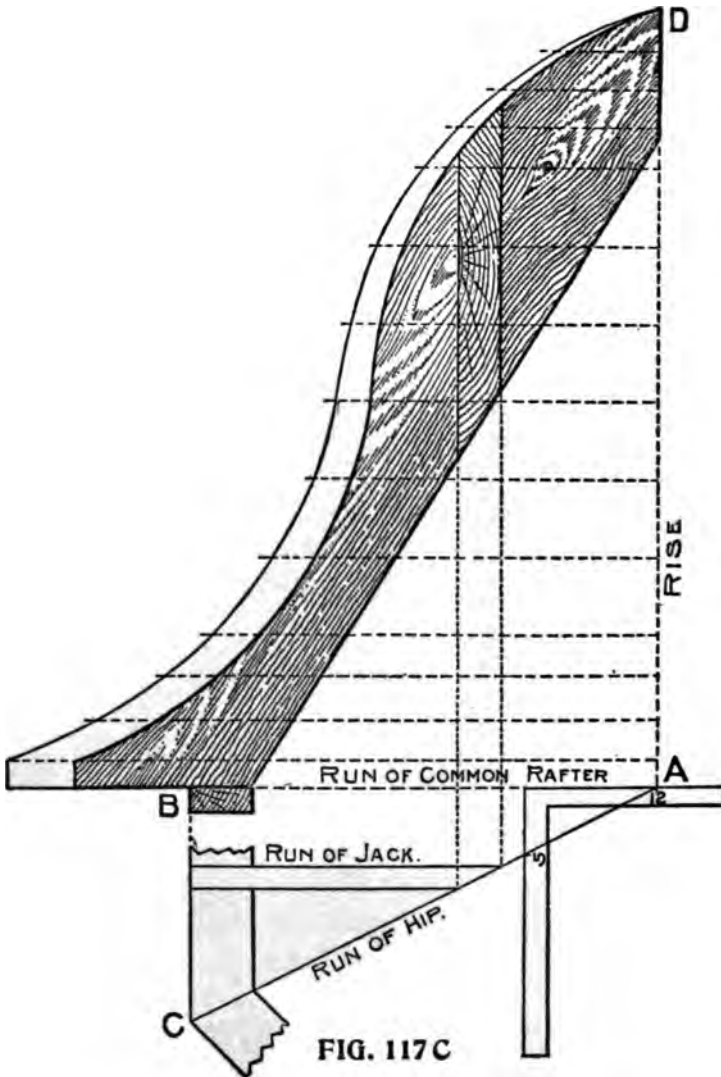

FIG. 117 B

is one-sixteenth of the plan, and is all that is necessary to draw.

Now, lay off the rise AD, and the desired curve



for the common rafter, and draw any number of lines parallel with AB, from the rise to a few inches beyond the curve of the common rafter. Now, measure these lines from rise to curve, and

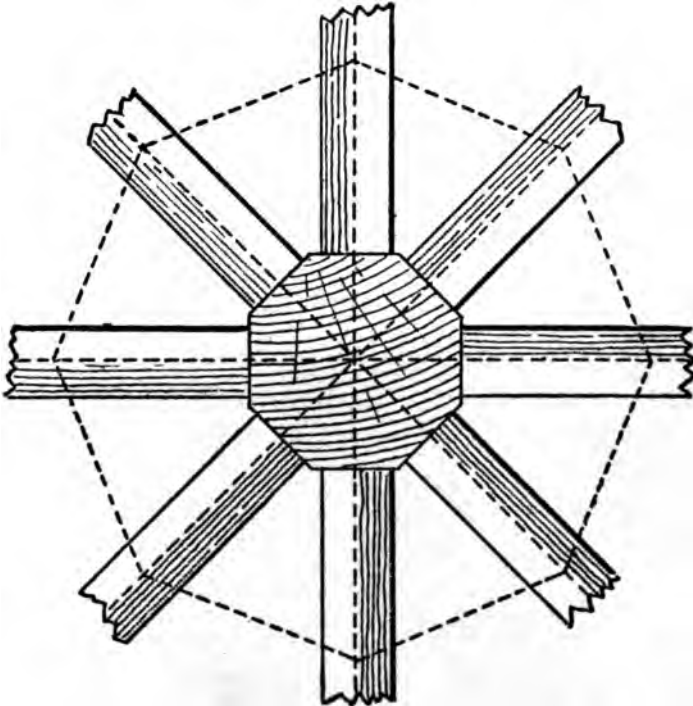

FIG. 117 D

for each foot and fraction of a foot add to same line as many inches and twelfths of inches as there are feet and inches in length.

In other words, if a line 6 feet and 9 inches long, add to its length 6 and nine-twelfths inches and make a dot. After all lines have been thus

measured, run an off hand curve through the dots, and the corresponding hip is determined.

To Find Shape of Jack.—The jack being a part of the common rafter, its shape is easily found by laying off the run and squaring up as shown.

It is thought better to run only the hips to center, and by using an octagon-shaped block or pole set with the sides, so that the hip will rest against it squarely, so as to get good nailing, as shown in Fig. 117d; besides letting the block extend above roof, furnishes an excellent stay for a finial.

To Find the Backing for a Curved Hip, measure back from the face, on the horizontal lines, one-half the thickness of the hip and run an off hand curve, as previously done for the face line, and this will be the proper gauge line along the side of the hip. It is very important that the hips should be backed in roofs of this kind, because the shape is ever changing and the backing should correspond.



Part X

POSSIBILITIES OF THE STEEL SQUARE

Polygon Family Circle—Laying out a Circular Frame—Framing to Any Degree—Ornamental Figures in Miter Work—Arrangement of the Triangle—Application of Degrees—Drawing a Heptagon—Tangents and Co-Tangents—Degree Line of Triangle and Hexagon—Laying Off Degrees with Compasses—Foundation of Miters—Fractional Value of Decimals.

What may not be accomplished with the aid of the steel square in the construction of useful and ornamental diagrams would indeed be a hard question to answer. It is safe to say that there can be no tool devised that will ever supersede the steel square in covering so wide a range in the various construction arts. It is all contained in the simple scale of measure in connection with the 90 degrees formed by the arms of the steel square ready to solve the most intricate problems when knowingly handled by the operator.

In presenting these illustrations, it is our aim to put them in such a way that the reader will readily understand the principle involved so that they may be intelligently reproduced, and thereby assist in opening up the way for much useful information.

Polygon Family Circle.—In Fig. 118 is shown the polygon family circle. In this, we show

reader will notice this, that a corner of each polygon is resting at 12 on the tongue, while in the next illustration, as shown in Fig. 119, they are, so to speak, run down at the heel. In this

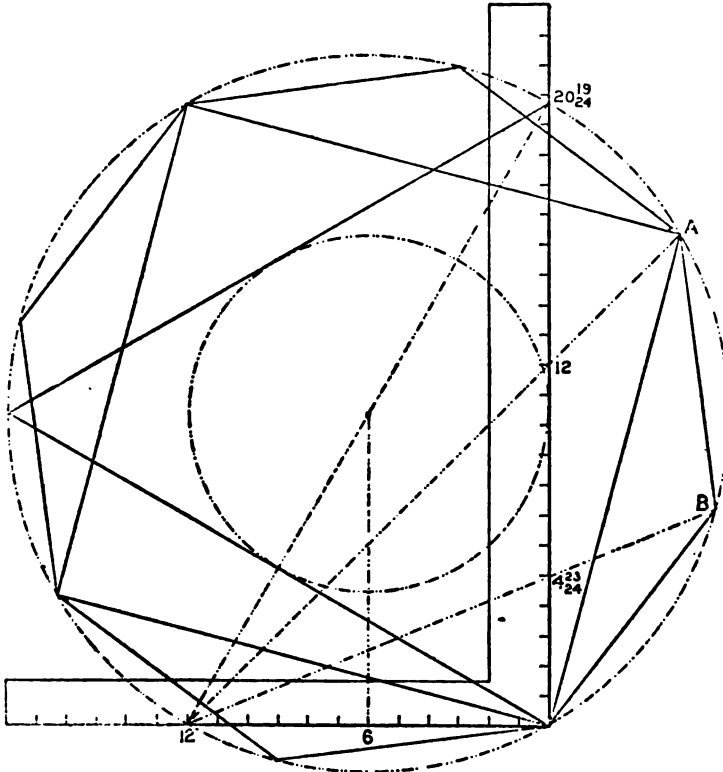

FIG. 119

illustration only the triangle, square and octagon are shown and are enclosed in the circumscribed diameter of the triangle with an inscribed diameter of one foot. In this the lengths of the sides of

the polygons are determined from the heel of the steel square to the intersection of the miter lines with the circle as from the heel to A and B for the square and octagon respectively.

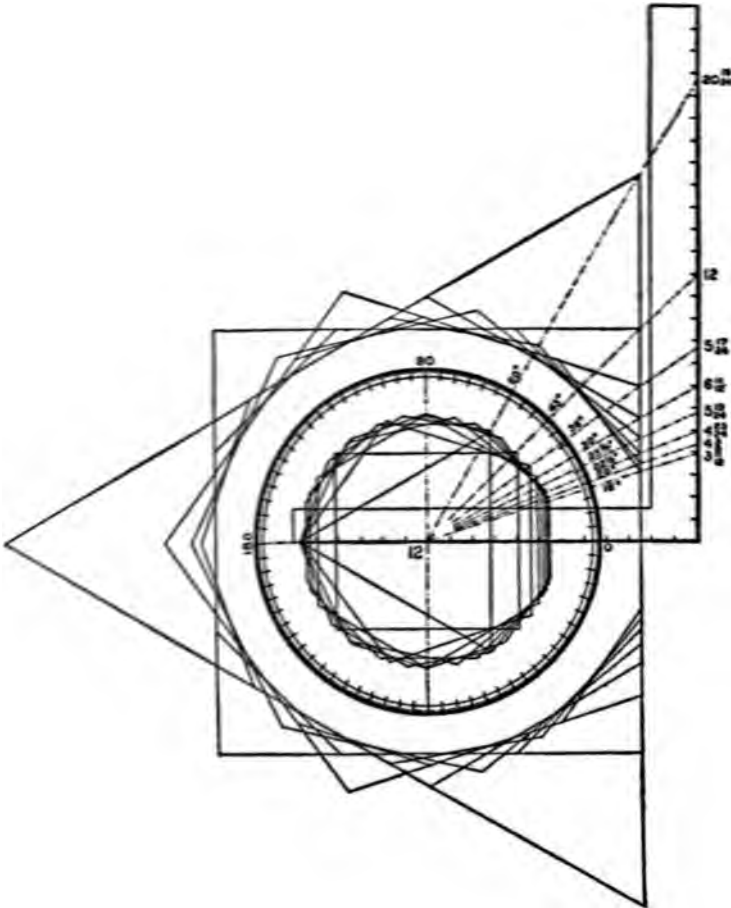

FIG. 120

In Fig. 120 are shown two sets of polygons in connection with the degrees and according to

the scale, the inner set is drawn to a circumscribed diameter of one foot, while the outer set is drawn to an inscribed diameter of nineteen inches. The starting point in either case is at midway of the sides of the polygons, and the more drawn, the more nearly a true circle they will form. In the former, the corners form the circle and in the latter the central part of the sides lends to the shaping of the circle.

In Fig. 121 are shown the polygon circles. In this illustration each polygon has its individual circle. Beginning with the triangle we show the miter lines for eight of the polygons and by squaring up from 6 on the tongue and at the intersections with the miter lines determine the center of the circles. The reader will notice that each circle cuts at three points on the steel square, also notice the dropping down of the circles and the shadows they cast at the two lower points of the steel square. At first glance it might appear that the circles are not true, but a more careful inspection would show that they are as true as can be described with the compass. The descent of these circles from the triangle down to the decagon is quite rapid, but from this on down it would be a very different thing. The miter lines of a polygon having 180 sides would intersect the blade at one degree, or .21 (5-24) which is less than one-fourth of an inch, and would be the length of the sides of the polygon with an inscribed diameter of one foot. The miter line for a polygon having 360 sides would intersect the blade at

.10476. From this it would appear that the continued increase of the sides of a polygon of this size would become too short to be discernible,

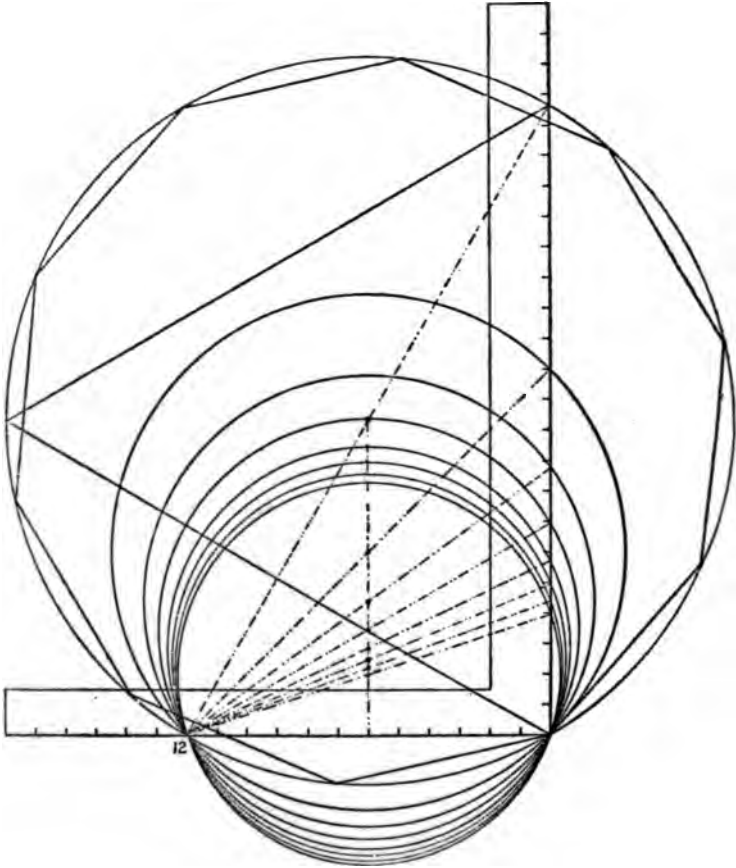

FIG. 121

yet according to trigonometry they could go on and on multiplying in number of sides and the decimal would never be entirely disposed of,

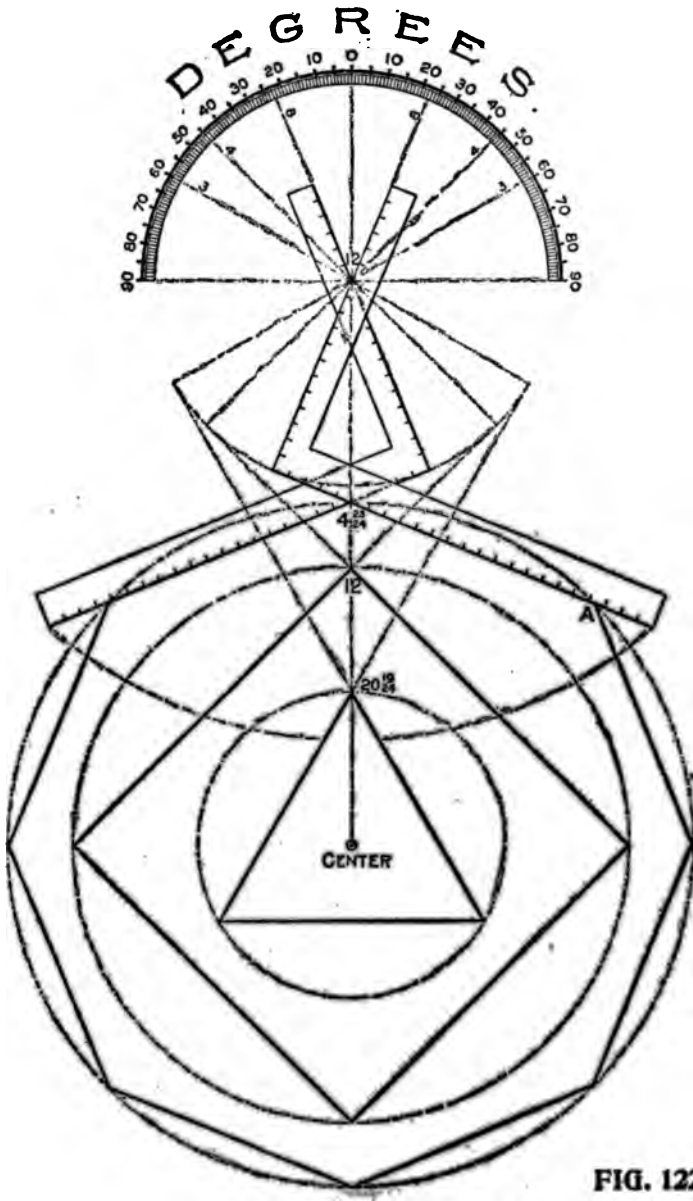

FIG. 123

leaving it in the infinitesimal or where the polygon really ends and the true circle begins.

In Fig. 122 is shown another way of handling the steel square in laying out the polygons. Here we show two squares as though they were pivoted at 12 on the tongue and made to work like a pair of shears. Just above this is shown the semi-circle with its 180-degree divisions also centering at 12. The degrees are read from the top each way and are to the steel square as the dial to the weighing scales. Thus, to find the side of an octagon, divide 180 by 8, equals $22\frac{1}{2}$. Now swing the blades up until the tongues are in lines with $22\frac{1}{2}$ degrees and the angle formed by the blades will be that of the octagon corner as shown in the illustration, 12 and the figures at the intersection of the blades (4 23-24) will give the required miter. The blade giving the cut. By laying off the desired circumscribed radius on a line directly below the intersection of the blades and where the circle intersects the line of the blade as from 4 23-24 to A will be the length of the desired sides. The quotient for the square, or tetragon, is 45, and that for the triangle is 60 degrees, as shown. For effect in the illustration, we have used one common center for the above polygons. The dotted lines represent the space over which the steel square would travel in laying out these polygons. By using the same center, the pentagon, hexagon and heptagon would come in their order between the tetragon or square and octagon,

and continue on as the number of sides is increased in the polygon.

We have one more illustration along this line we wish to present, as shown in Fig. 123. In this

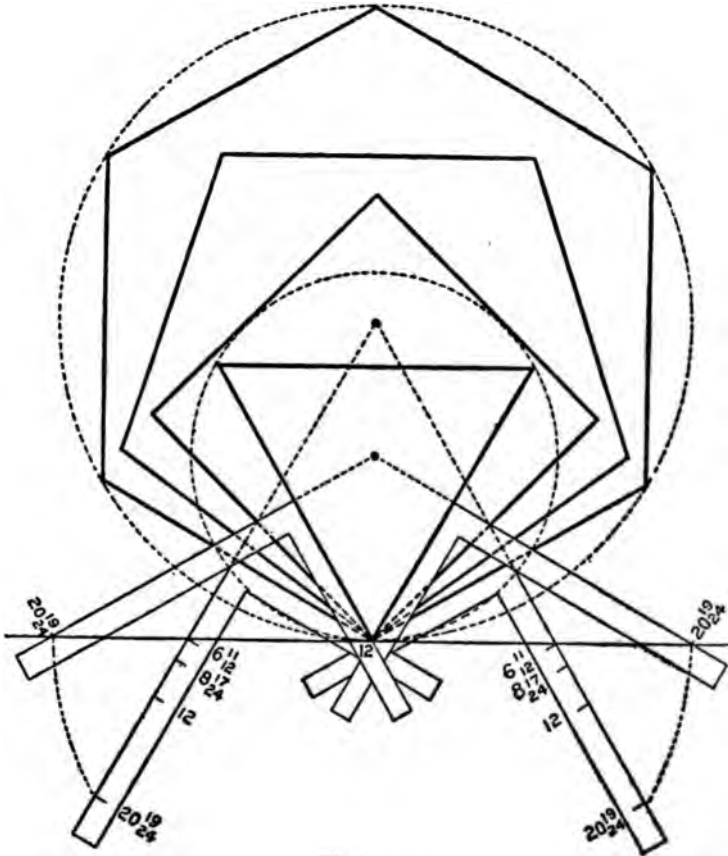

FIG. 123

we show four of the polygons beginning with the triangle and developed with the aid of the steel square from a straight line. The application of

the squares is shown for the triangle and hexagon with the figures given for the square and pentagon. Now just suppose the tongues of the steel square are pivoted at 12 to the line as shown. Now by raising the blade up until the figures on the one that give the miter, intersects the straight line, the angle formed by the tongues will be that of the corresponding polygon. According to the illustration the sides of all of the polygons are 24 inches in length, though they could be by this method laid out to any desired length and by squaring out from the sides at one-half of the desired length and the intersection of these lines will be the center of the desired polygon.

Laying Out a Circular Frame.—In Fig. 124, is shown how any part of a circular frame may be laid out with the aid of the steel square. If we wish to lay out one-sixth of the frame, it may be done as follows:

Lay off the desired radius as from A to B then apply the square with the 12-inch mark at A as shown and draw a line from 12 on the tongue, passing at 6 11-12 inches on the blade and drop to an equal amount on a plumb line below the heel, then that part of the frame as from C to D will represent one of the desired pieces, and by applying the square to the chord line, as shown, will give the required miter. Proceed in like manner for four pieces, using 12 on the blade and the space from E to F will be one of the desired pieces. The space from C to B represents one-twelfth and from E to B, one-eighth of the complete

circle, but since the chords are changed, it requires the figures on the square that give the miters for the respective polygons.

Framing to Any Degree.—In Fig. 125 is shown how to frame to any degree. For an example,

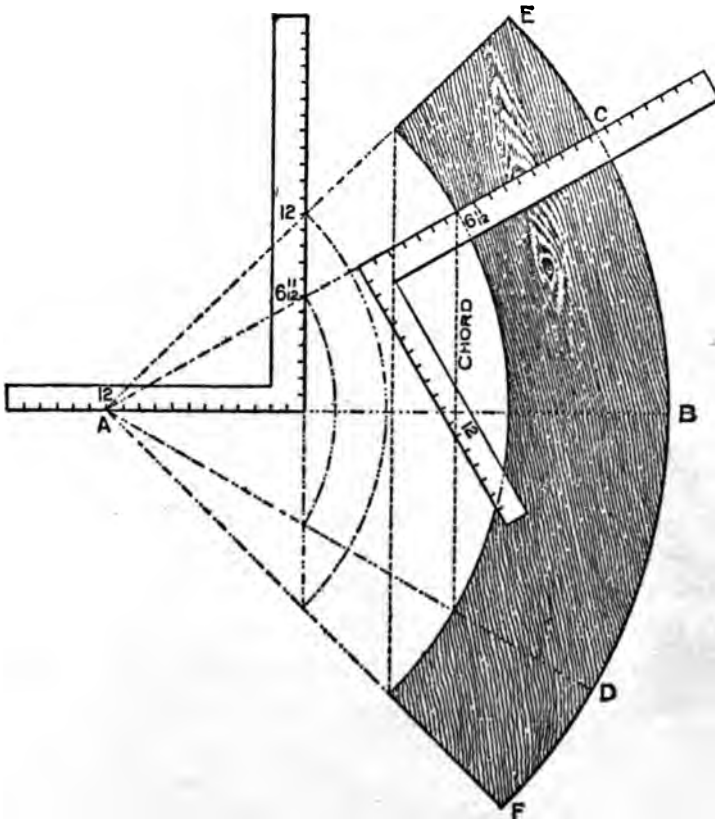

FIG. 124

say we wish to frame two pieces at an angle of 152 degrees. It is evident that the miter should stand at half way between the angle, or at 76

degrees from either side, and 76 degrees from 90 degrees leaves 14 degrees. We find the tangent for 14 degrees to be 2.99 or practically, 3 inches. Therefore, 12 on the tongue and 3 inches on the blade will give the miter, the latter giving the

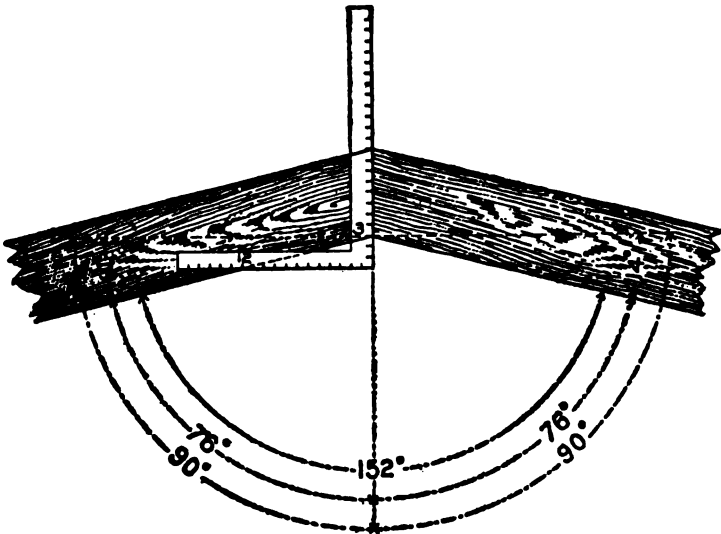

FIG. 125

cut. The square as placed would give the cuts for a brace set to either 14 or 76 degrees.

Ornamental Figures in Miter Work.—We will now call the attention of the reader to a few ornamental figures in miter work that may be accomplished by the aid of the compass and steel square. In this there is a wide field for culture with practically no end. We have prepared for this work a few designs along this line and the mechanically inclined will find in these excellent

practice and if he has an eye for designing, these also will furnish a nucleus upon which to plan other designs that will not only give practice and perfection in handling the steel square, but will help to broaden his knowledge in its use and place him on a higher plane in his chosen profession.

The equilateral triangle is more susceptible of changes in ornamental design than any of the other polygons for the reason that the length of its sides are the radius of the circumscribed diameter of the hexagon. Its area being one-sixth that of the latter, and the same figures used on the steel square for the miter of one also gives it for the other as we have previously shown.

Arrangement of the Triangle.—The triangle can be arranged in many designs or patterns and leave no intervening spaces, as will be seen by



FIG. 126

referring to Fig. 126, which adapts itself to ornamental tile or inlaid work. Even the little honey bee understands the geometric principles in space saving and constructs her store house accordingly in hexagonal cells, which are in the form of six

equilateral triangles and so arranged that they interlock each other as shown in part of the illustration. The equilateral triangle may indeed be classed as the monarch of all the polygons, for within its lines as a basis, any of the other polygons may be drawn to any desired size, as we will show later on under another head.

In Fig. 127, is shown a hexagonal figure in general design and all of the miters can be had on

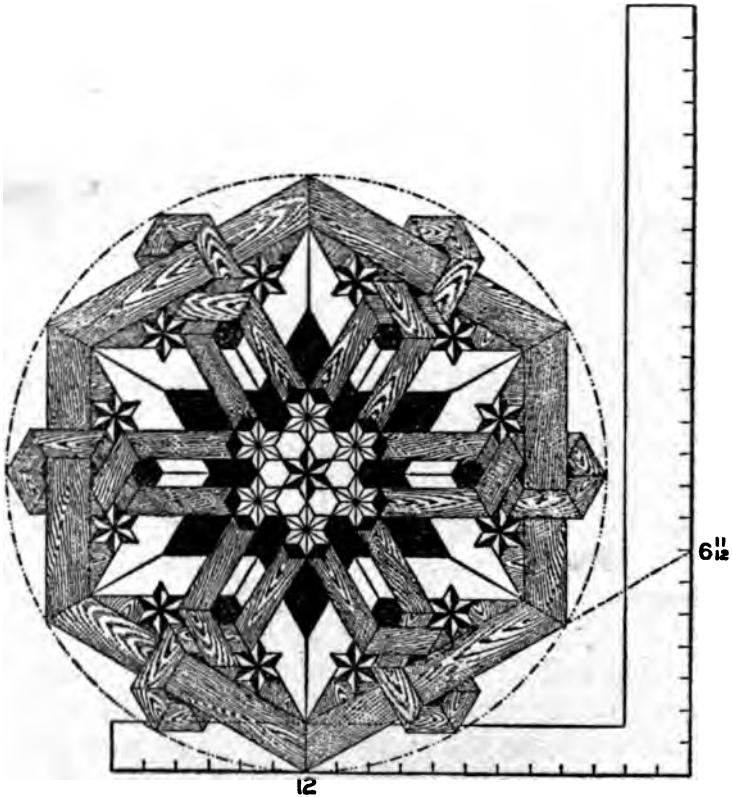

FIG. 127

12 and 6 11-12 as indicated on the square. The blade giving the hexagonal and the tongue the triangular cuts. This proportion, of course, the reader will understand, taken at any other part on the blade and tongue would give the same result, as every fractional part of the divisions on the blade represents a scale, but we will not take the time now to explain. The same cuts exist again at 12 on the tongue and 20 19-24 on the blade, but the cuts on the square are just the reverse.

In Fig. 128 is shown another design and is worked on the same degree lines as in the previous figure; what we said of that figure is just as applicable to this figure. Either of these designs furnish good examples for inlaid work and with care in selection of color of wood would make a very attractive piece of work.

Application of Degrees.—Too much cannot be said as to the possibilities that come in range of the common steel square in connection with the degrees contained in the eighth part of a circle as applied to the right-angle triangle and their tangents. For they cover the whole field of miters whether on a level or incline plane. The illustrations that we have been giving pertain to the miters resting at a level plane, but they form the basis for miters resting at an inclined plane, which pertain to the side cuts of rafters for any shaped building, the working out of geometrical hand railing, etc.

In Fig. 129 are shown three hexagonal star-

shaped frames inclosed in circles and these are contained in one large hexagon and the whole in one large circle.

The reader will notice that the figures given on the square are the same as those given in previous illustrations for the miter of the hexagon.

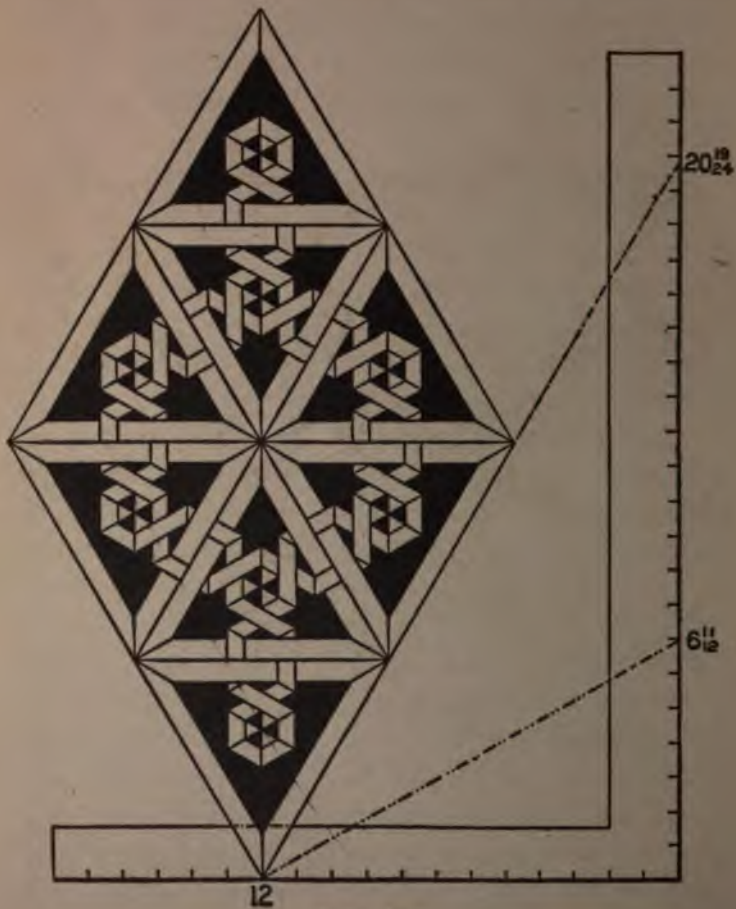

FIG. 128

The blade will give the angle for the inner points, while the tongue will give it for the outer points, or if 60 degrees is used, which falls at 20 19-24 on the blade, then the angles will be just the reverse on the square.

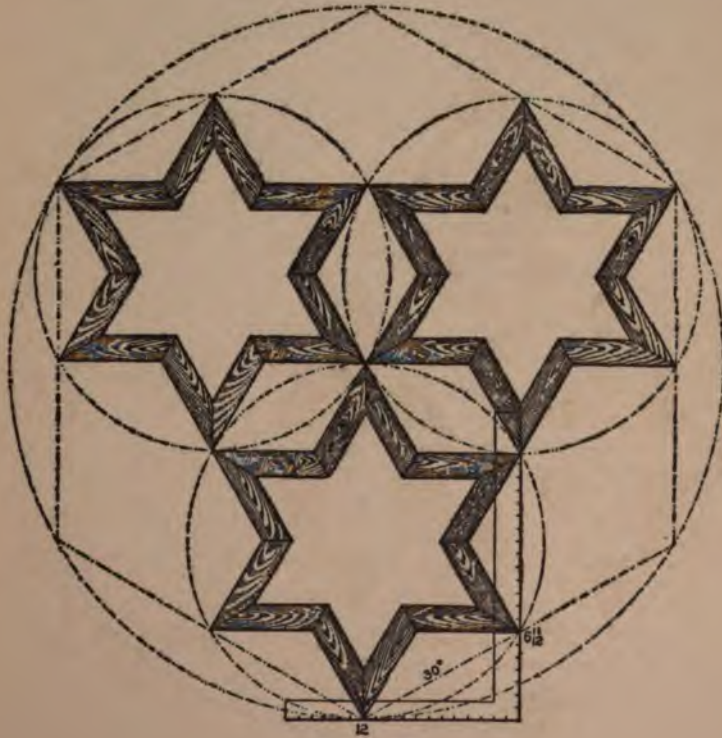

FIG. 129

In Fig. 130 are shown six squares laid in pairs with their blades and tongues intersecting each other at the figures that give the hexagon miter, and produces one of the most beautiful examples

in miter work. All of the angles about the squares form some part of the hexagon and it will be seen that the large circle that incloses the figure is equally divided into six parts.

In Fig. 131 is shown another form of drawing polygonal figures. In this we show two squares,

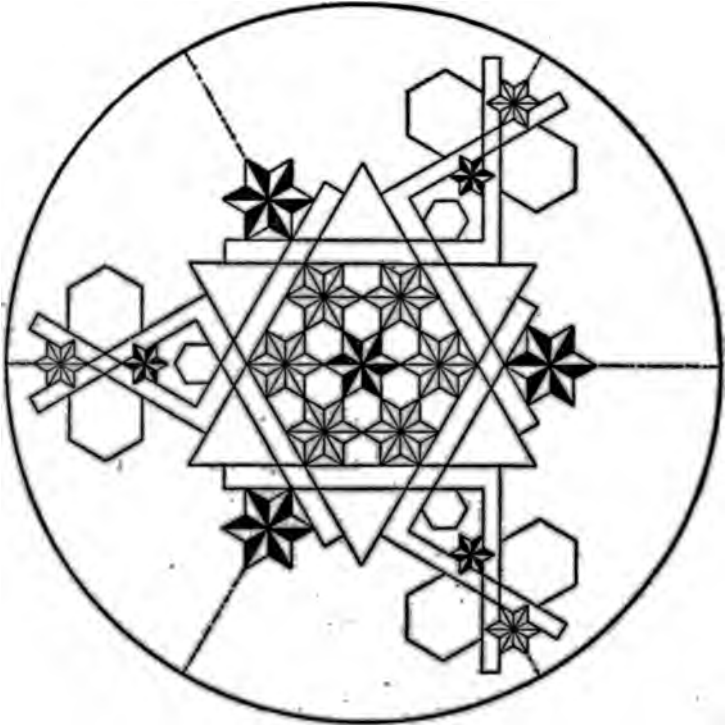

FIG. 130

though only one is needed. The second one is given for effect in balancing the drawing, as it will be seen that the same figures are used on both squares. The degree lines leave the 12 on the

tongues at 15 degrees apart and intersect the figures on the blade as shown. Now since 15 is a multiple of the number of degrees that form several of the polygons, they are contained in

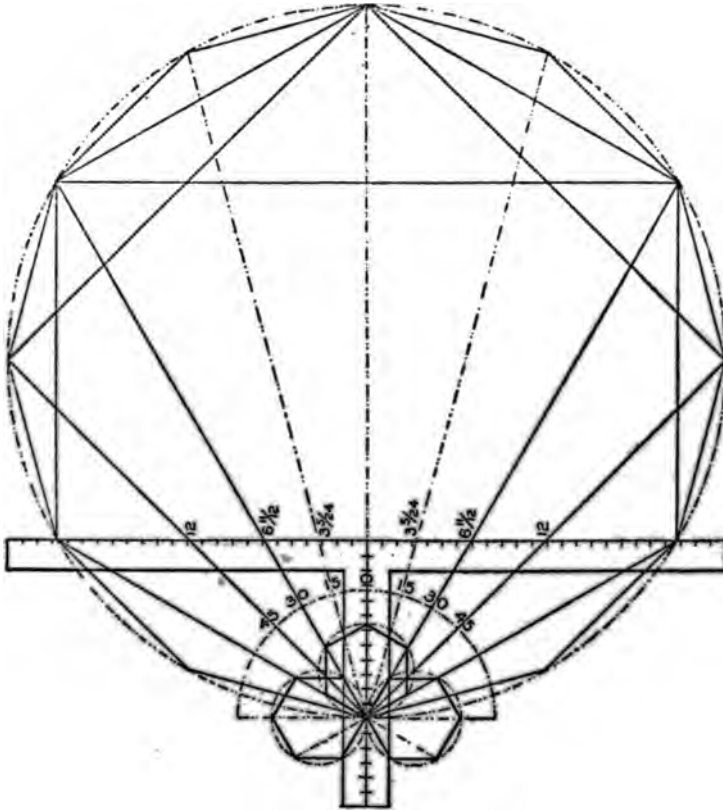

FIG. 131

this figure, as 15 is contained in 180 twelve times, 30 is contained six times, 45 is contained four times and 60 is contained three times. By referring to the illustration the reader will see that

polygons of the above number of sides are all contained in this figure.

In Fig. 132 we have carried the above a little further, showing the same polygons as in the pre-

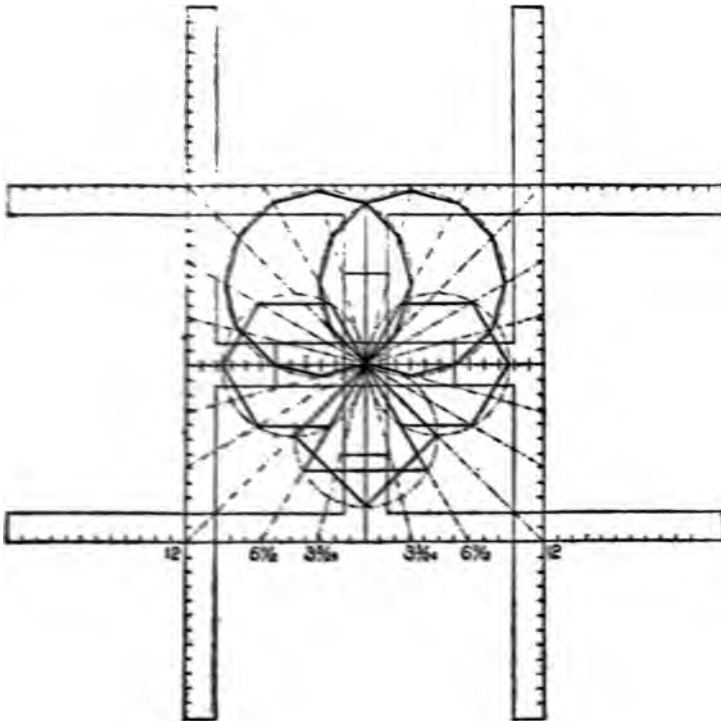

FIG. 132

ceding figure, but in this case they have blossomed out into a flower.

In Fig. 133 is shown a diagram whereby the angles and dimensions for any of the polygons may be accurately drawn by a system of lines passing through 12 on the tongue of the square.

For illustration we have taken the heptagon or seven-sided figure.

The semi-circle 7-A is first drawn, which may be to any desired size. Place the steel square as shown with the 12-inch mark at the center.

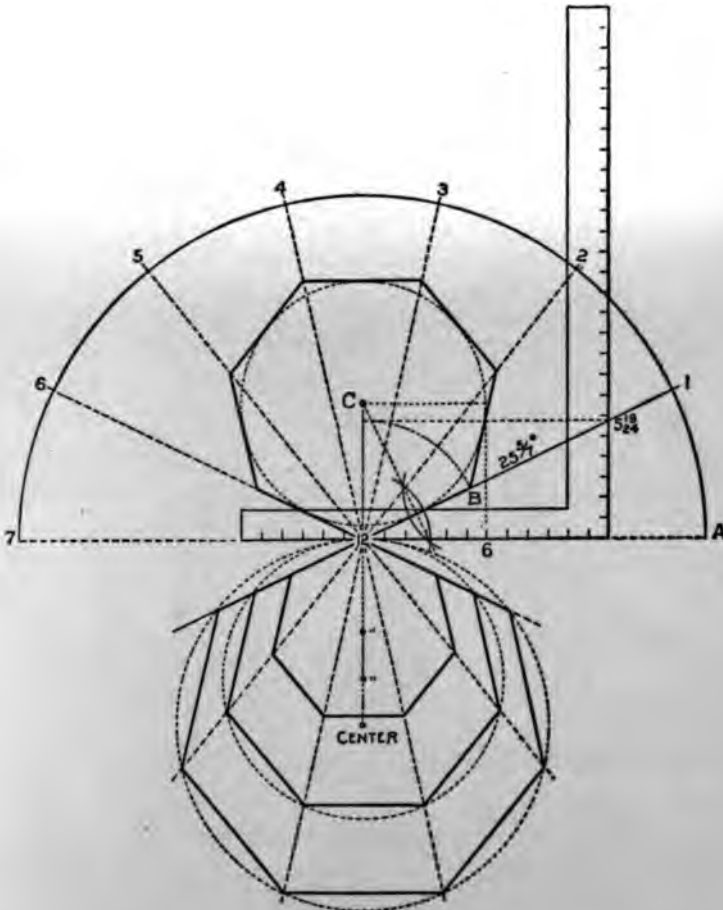

FIG. 133

Then draw a line from 12, passing at 5 19-24 on the blade (which are the figures to use for the miter), and continue on, intersecting the semi-circle at 1. Then A-1 will represent one-seventh of the semi-circle and is equal to the spacing set off at 1, 2, 3, etc. Draw lines from these points to the center at 12, as shown.

Drawing a Heptagon.—Now, suppose we wish to draw a heptagon with a twelve-inch inscribed diameter. Set off 5 19-24 on the line 12-1, as at B, and bisect the line 12-B as shown, and where the bisecting line intersects the perpendicular line from 12, as at C, will be the center from which to strike the required radius.

By indefinitely extending the lines 1, 2, 3, etc., below 12, as shown, heptagons with any desired circumscribed radius may be readily determined by simply setting off the radius on the perpendicular line as shown, and where the circle cuts the extended lines determines the length of their chords or sides. In the illustration we have shown three sizes. Proceed in like manner for any of the other polygons, but using the figures on the blade of the square that give their miters.

In Fig. 134 we show two squares with the blades and tongue intersecting at the figures that give the pentagon miter, and as will be seen, all of the angles form part of the pentagon. The stars are shown in connection with the same to further illustrate the accuracy of the illustration.

In Fig. 135 the lines are at 18 degrees on the square at the lower point of the star, and as will

be seen, gives the miter for a frame star shape, the tongue giving the angle. From this it will be seen that the tongues of these squares are in a

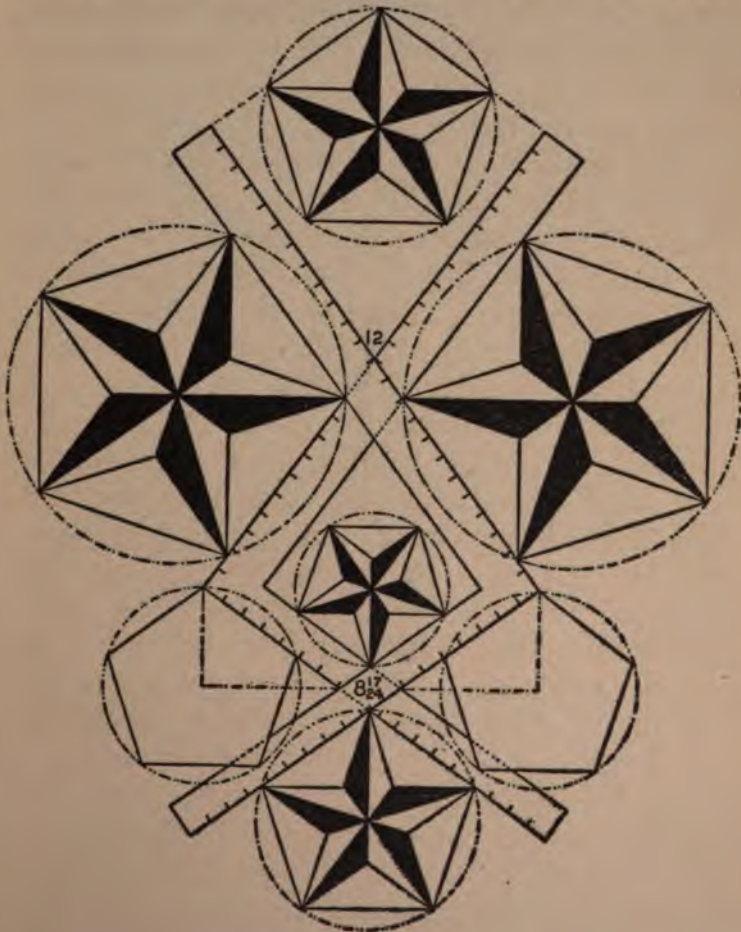

FIG. 134

direct line with the center of the star. The squares at the top are set at 36 degrees, with

their tongues in line with the 18 degree lines from the two lower squares, and form the angles for other parts of the star.

It will be seen that a star-shaped figure can be systematically framed either in the solid or in

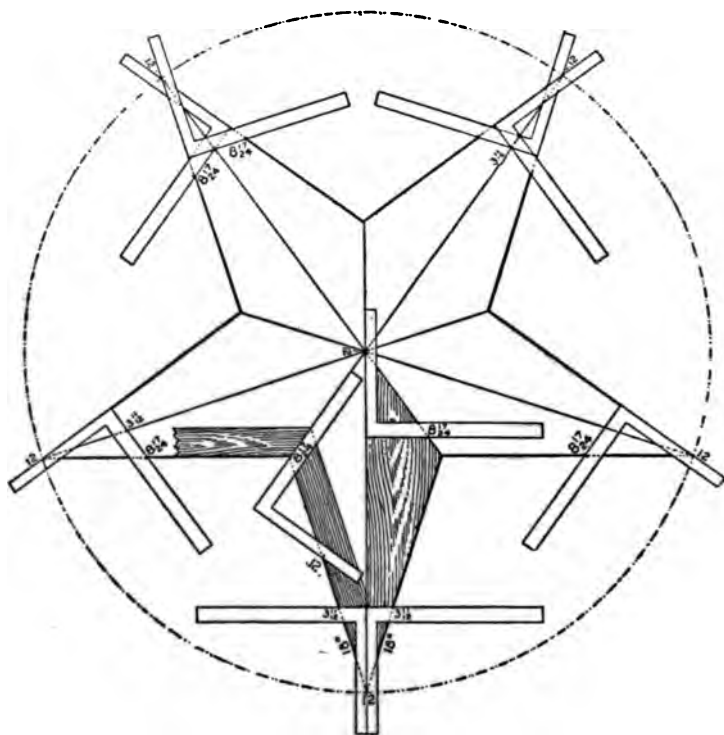

FIG. 135

part, as shown, and that without first laying out a full-sized diagram, and the ten pieces will fit to their respective places. The figures 12 and 8 17-24 also furnish the basis for framing a root of

this shape, and the general rule that applies to this, applies to all angles.

Tangents and Co-Tangents.—In Fig. 136 we have tried to make the subject of tangents and co-tangents clear by the use of two steel squares,

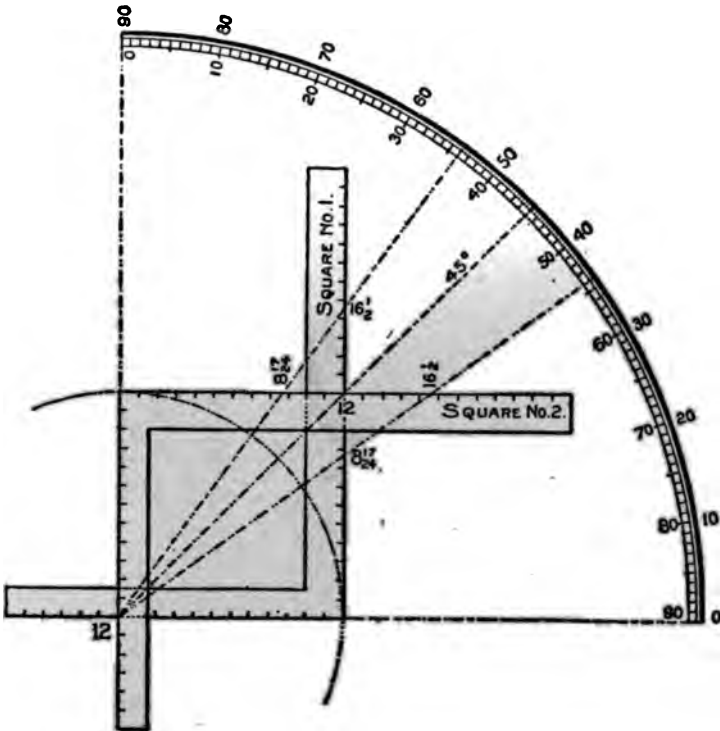

FIG. 136

placed as shown in connection with the quadrant. The blades and tongues intersecting at 12 and 12. Now, since a tangent is simply a straight line touching the side of a circle, we let the blades represent the straight lines intersecting a circle

described from 12 on the tongue. Reading from the bottom up, the 36-degree line passes at 8.72 (8 $\frac{17}{24}$ inches) on the blade of square No. 1, and from this back to the heel is the tangent. Now, referring to square No. 2, what was 36 degrees

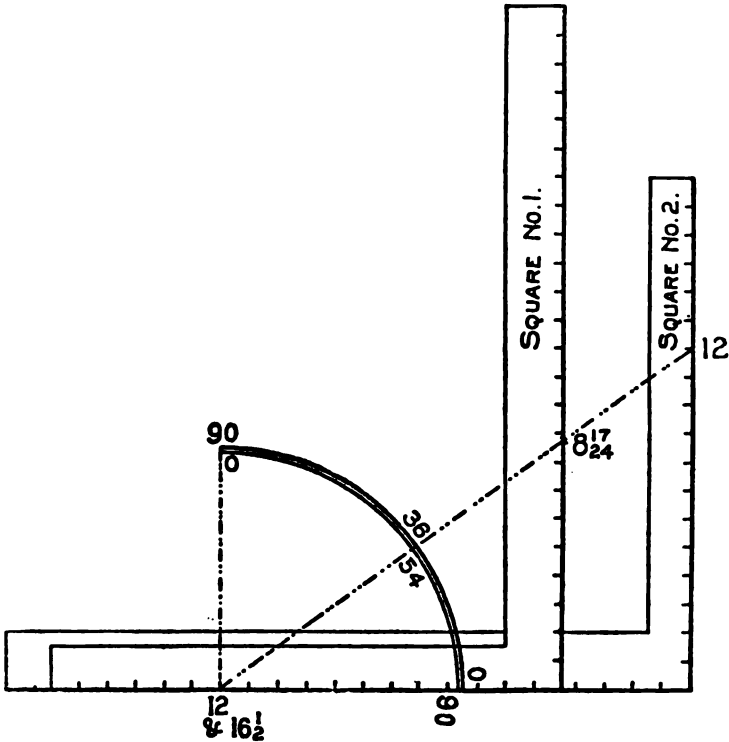

FIG. 137

on square No. 1 is 54 degrees, and passes at 16.51 (16 $\frac{1}{2}$ inches), and from this point back to the heel is the co-tangent. Both squares give identically the same cut, in other words, what the

tongue gives in one, the blade gives in the other. If we read the degrees from the top to the right, we have the same thing, only reversed on the square.

The 45-degree line, being at the half-way place on the square, remains unchanged. To illustrate this point a little further, we show two squares in a different position, as shown in Fig. 137,

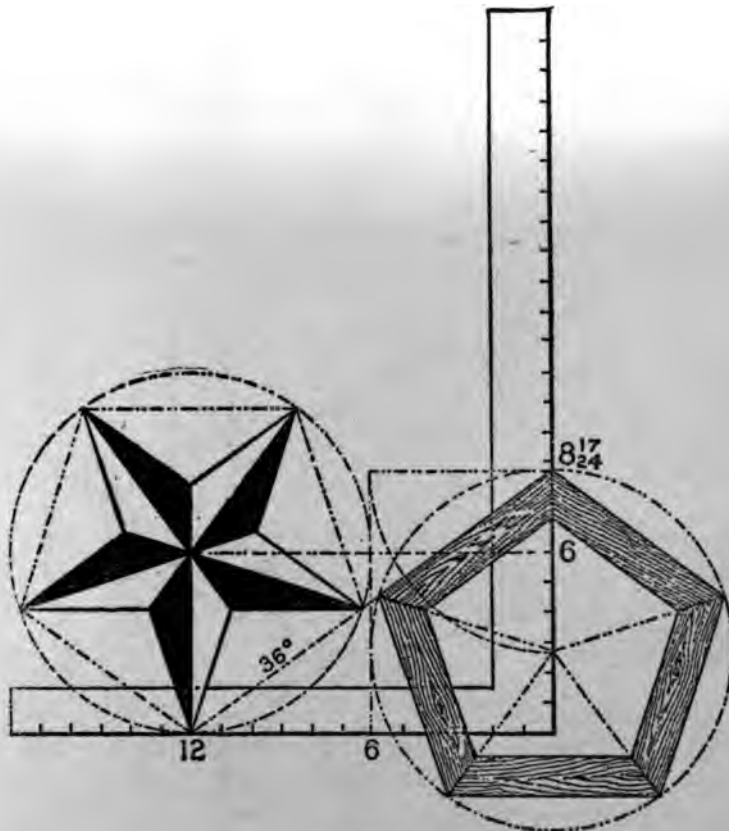

FIG. 138

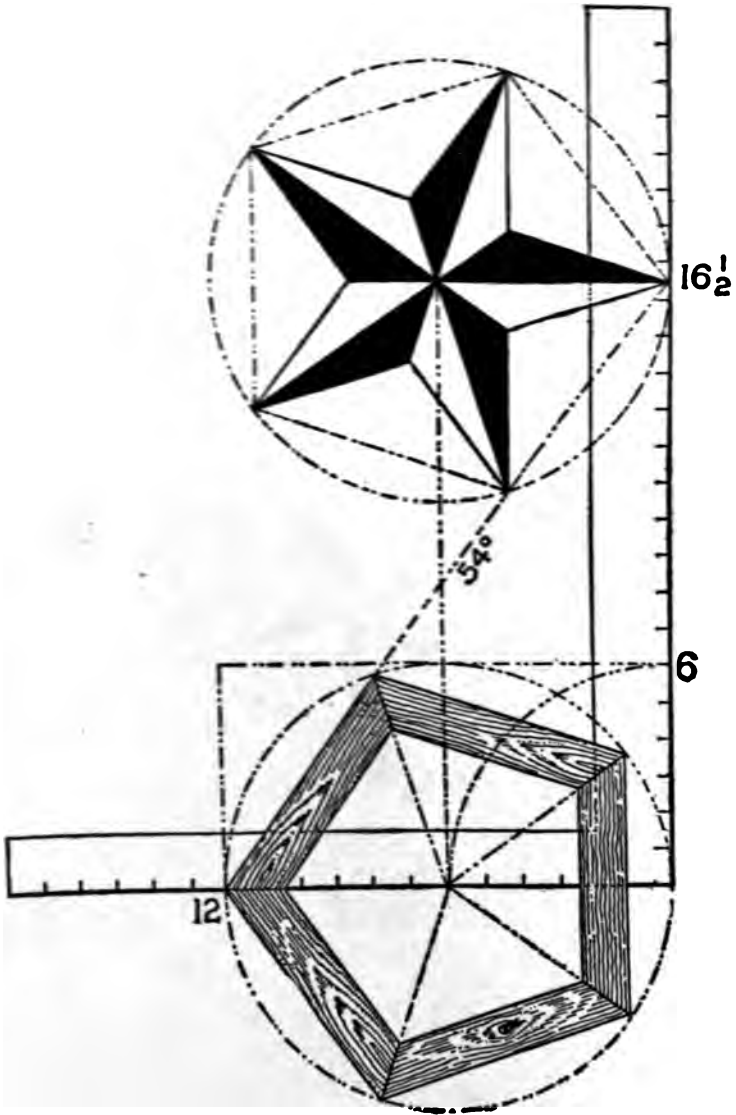

FIG. 139

using the same figures on the squares as in Fig. 136 for the 36 and 54-degree line. Taking the squares separately, we show in Fig. 138, using the 36-degree line, the pentagon miter on the blade and the pentagon star resting at 12 on the tongue; while in Fig. 139, using the 54-degree line, the

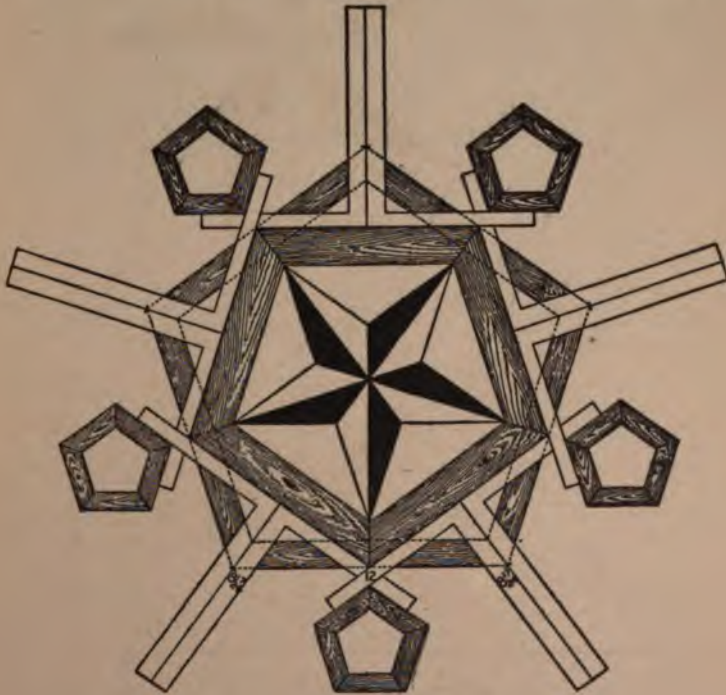

FIG. 140

reverse is shown. In both of these illustrations the pentagon frame and star are inclosed in a circumscribed diameter of 12 inches, but they could be of any desired size.

We have one more pentagonal illustration as

shown in Fig. 140, we wish to present before passing on to some of the other polygons. We could go on and show other positions of the steel square in forming the pentagon and its miters, but the figures used on the steel square would conform to the figures here given or to their ratio. We will now call the reader's attention to some of the other polygonal figures, applying the same rule as for the pentagon or five-sided figure.

Degree Line of Triangle and Hexagon.—The triangle and hexagon are the only polygons whose

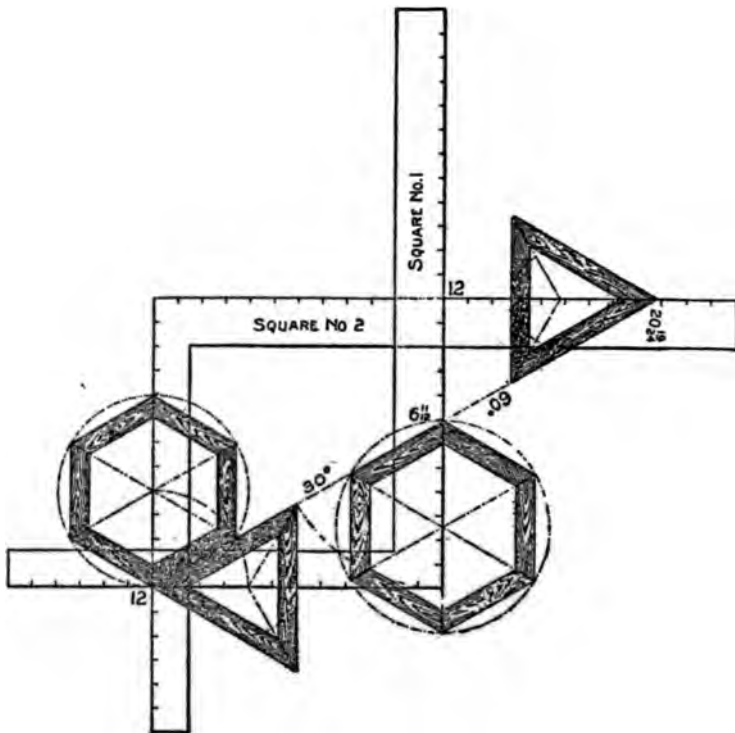

FIG. 141

miters can be had on the same degree line, which permits of using the same figures on the square as shown in Fig. 141. In this, we show two squares with but one degree line, which is 30 degrees on the square No. 1 and 60 degrees on square

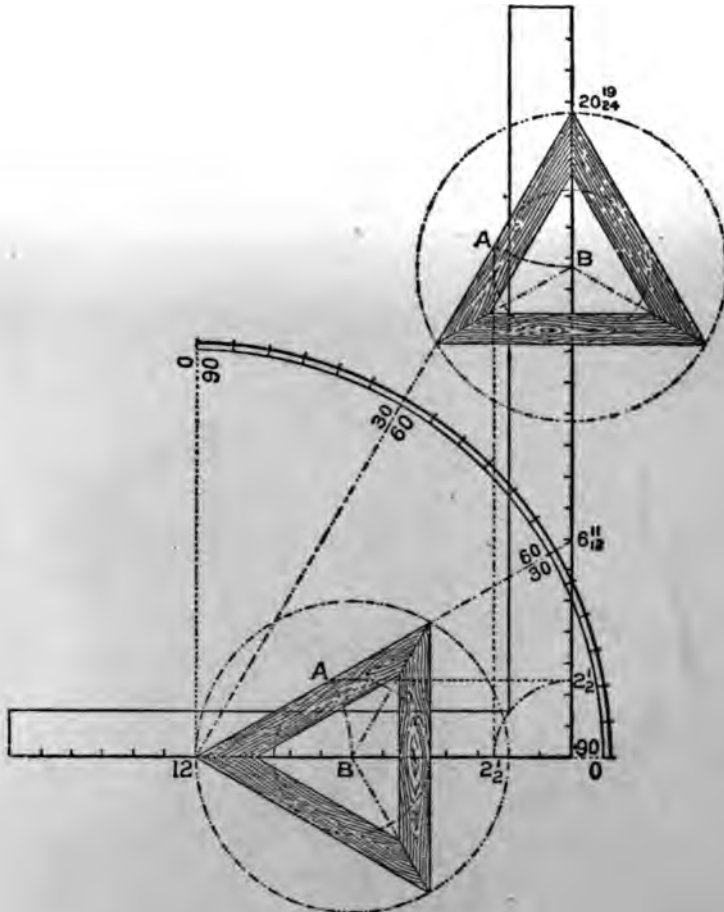

FIG. 142

No. 2 and both giving the same cuts but reversed on the squares. Perhaps this point could be made more clear by using but one square as shown in Fig. 142. In this, the degree lines are shown for the 30 and 60 degrees and both giving the miter for the triangle. The tongue giving it in the former and the blade in the latter. In this example, we show how to lay off a triangle of any inscribed diameter by setting off the radius, say $2\frac{1}{2}$ inches on the blade as shown, and squaring out to the degree line as at "A." Then with the length from 12 to "A," set off on the tongue will locate the center as at "B," or vice versa if the cut is wanted on the blade.

In Fig. 143, we show a circle with the degree divisions spaced on same with the aid of the steel square. We do not claim this to be the best way, nor would we use this method if we had a job of this kind to do, but it can be done and that very accurately, by letting 12 on the tongue rest at the center and checking on the blade as follows: $2\frac{1}{2}$, $4\frac{1}{2}$, 6 11-12, 10 1-12, 14 7-24 and 20 19-24 inches, which places the degree lines ten degrees apart. Then swing the square till the tongue rests in line over the last check and repeat the markings. Six movements of the square will complete the divisions and with a straight edge, which may be the blade of the square passing from the center and over the check marks, will divide the circle in divisions of ten degrees, and these may be divided with a compass into ten spaces, designating the degrees. Of course, the whole circle could have

been divided with the compass by first dividing the circle into quarters or sixths and these spaces again into the required divisions, but the reader will understand that we are illustrating what may be done with the aid of the steel square. How-

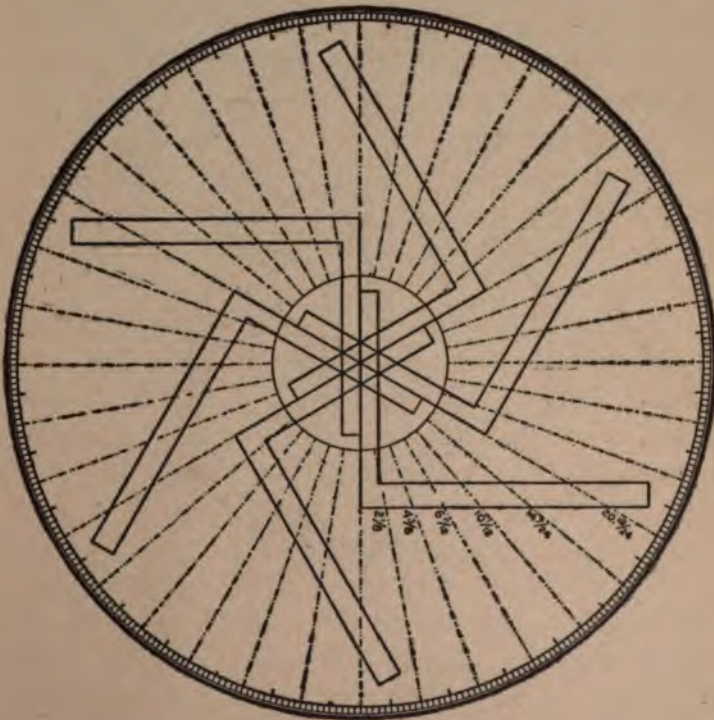

FIG. 143

ever, it will not be out of place to show what may be done with the compasses alone in laying off the degrees on the circle as shown in Fig. 144, and may be drawn as follows:

Laying Off Degrees With Compasses.—With the compass describe the degree circle and without changing the radius, set the needle point at any place on the circle, describe another circle and at the intersection with the first circle, describe

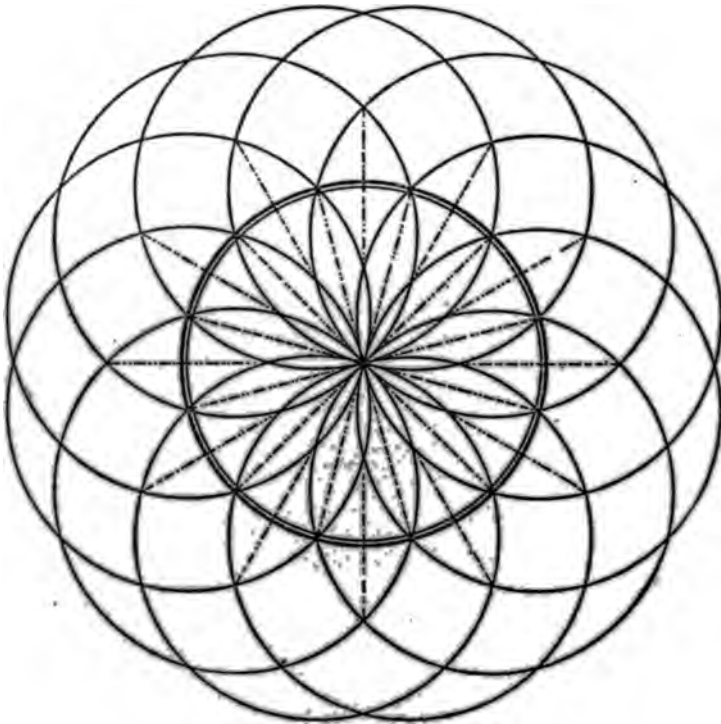

FIG. 144

another circle and continue until all of the intersections have been used; then with a straight edge lay off the lines through the center to the intersection of the points of the outer circles. It will be seen that the degree circle has been

divided into twenty-four equal divisions or 15 degrees apart. These divisions could be again divided in like manner down to 5 degrees by setting the needle point at one-third of the space on the circle and thereafter on the intersections as described above.





Index to Volume 1

	PAGE
Acute roofs, rafters for.....	43
Adjustable fence	33
Affixing stair strings	166
A formula in figures	79
Angle block in position	157
Angles and bevels for hopper work.....	128
Angles formed by division of circle	94
Angles in regular and irregular miters.....	136
An unequal pitch	74
Application of the fence.....	34
Application of degrees.....	223
Application of steel square to trusses	146
Arrangement of the triangle	221
Backed hips	92
Balusters for stairs	168
Bed moulds for gable, to cut	81
Beveling of hip rafter	81
Bevels of hips and jacks	101
Bevels for top of vertical boarding	46
Bevels in octagon roofs	101
Bevels of purlins, how to find	90
Board measure	28
Board, plank and scantling measure	27
Board rule	28
Brace, how to make pattern for	35
Brace rule explained.....	29

	PAGE
Brackets for stairs	168
Butt-joint, to find cut for.	123
Care required in selecting a square	22
Circle with degree divisions	240
Circular roof, how to pierce with saddle roof .	87
Circumferenc of the circle	132
Collar ties, to find bevel for	46
Combination squares	181
Common difference in length of jacks	190
Common rafters.	48-63
Compasses, uses and importance of	30
Complement pitch.	140
Connecting stair strings	166
Co-pitch	138
Corners, classes of	135
Cornice, projecting.	52
Co-tangents	233
Cove moulding.	159
Cripple jacks	101
Curved hip rafters.	61
Curve for octagon hip	205
Cuts and bevels	46
Cuts and bevels for flaring hopper	125
Decimal equivalent.	91
Degree framing.	91
Degree line of triangle and hexagon	238
Degrees, subject of	187
Description of the square	21
Definition of pitch	48

INDEX

247

	PAGE
Diagonal scale	24
Diagram illustrating roof pitches	91
Diagram of brace in position	38
Diagram of hip and common rafters in place.	68
Diagram of hopper in different views	121
Diagrams of hopper roofs	117
Diagrams of plan of roof	40-50
Diagram of scale enlarged and lettered	24
Diagram of side cut of hip or valley.....	70
Diagram of side cut of jack.....	70
Diagram of tower for windmill	150
Diagrams of various classes of hoppers	117
Different kinds of jacks described.....	111
Dividers, taking distance with.....	62
Divisions of the circle.....	94
Drawings, scale to measure	23
Drawing a heptagon	230
Drawing a five-pointed star	201
Drawing polygonal figures	226
Earliest builders	19
Elevation and plan of hoppers.	119
Ends of hopper, to find bevels and width of .	121
Explanation of angles in miters	130
Explanation of scales on steel square	23
Finding the bevels of purlins	90
Finish of wall string	170
Flaring hoppers, cuts and bevels for	125
Foot run for hips and valleys	66
Formation of a brace	35

	PAGE
Fractional pitch lines	92
Fractions, pitches and.....	43
Framing timbers	202
Framing a roof	192
Framing to any degree.....	219
Framing by degrees	95
Gable, to get length of valley rafter for	59
Gauge or fence on pitch-board	156
Gauge line, how made	156
General rules for using square	43
Greeks not the inventors of the square	19
Height and run of stairs	154
Hexagonal roofs	112
Hight's union combination square	183
Hip or valley for octagon building.....	49
Hip and valley roofs.....	63
Hip rafters	55-61
Hip roof framing.....	79
Historical and descriptive	19
Hoppers and hopper bevels	116
Housed or closed strings	161
How to cut jack rafters	68
How to cut planceer	81
How to determine the height and run.....	153
How to find cuts and bevels of trusses	146
How to find lengths of rafters	97
How to find miter	132
How to find the shoulder of purlins.....	85
How to get the bevels	46

	PAGE
How to lay off octagons.....	31
How to lay out hopper bevels	116
How to lay out rafters	40
How to make a miter box	175
How to make a pitch-board	155
How to obtain pitch of tower roof	54
How to pierce a circular roof with a saddle roof	87
How to test the square	22
Ideal bevel try square	184
Illustration of roof pitches	90
Illustration of side cut of jack	71
Illustrations of stairs	165-167
Illustrations of the pitch-board	156
Irregular braces, lengths and bevels of	38
Irregular miters	136
Irregular, uneven or unequal pitches.....	50
Jack rafters, how to cut.....	70
Jacks of different kinds described.....	41
Jack, side cut of, illustrated.....	70
Jacks, to find length of.....	54
Joints in hopper work	116
Keeping the old squares	21
Key to the steel square.....	187
Knowledge, open ways to.....	15
Laying off degrees with compasses	242
Laying off octagons	31
Laying out a circular frame	218

	PAGE
Laying out hopper bevels	116
Laying out of rafters	41
Lengths and bevels of irregular braces.....	38
Lengths and bevels of hips and jacks.....	101
Lengths and bevels or cuts of rafters	46
Lengths and cuts for one-third pitch.....	189
Length of common rafter	48-63
Length of hip rafter	56-57
Length of rafters, how to find	53-63
Lengths of jacks, how to find	54
Lines on square explained	23
Lip on upper edge of riser	160
Making a pentagon frame.....	199
Manner of using pitch-board	156
Measurement line of hips and valleys.....	67
Measurements of the square.....	26
Methods of finding the miter	132
Methods of laying out rafters	41
Methods of making stair strings	161
Minute measurements	24
Miter boxes	174
Miter cuts for hoppers.....	118
Miter cut for raking mould	179
Miter for any regular polygon.....	196
Miter, how to cut to fit hip	76
Miter joint, to find cut for.....	118
Miters.....	130
Moulding for stairs	170
Moulding or "cove," how used	159
Necessary appendage to the square	33

INDEX

251

	PAGE
Newel post of stairs	172
New squares in use	22
Nosing finish	169
Octagonal roofs	98
Octagonal scale explained	30
Octagon hip	68
Octagon jack, side cut of	70
Octagons, how to lay off	31
Old squares sufficient	21
Open stair strings	158
Open string stairs, view of	172
Open ways to knowledge	15
Origin of the square	19
Ornamental figures in miter work	220
Pattern for brace	35
Pentagon, or five-sided hopper	143
Pitch-board, how to make	155
Pitch of tower roof	54
Pitches and fractions	43
Pitches, illustrations of	91
Pitches of roofs	47
Pitches, reversed	49
Pitches, unequal	74
Pitch reckoned by degrees	91
Planceer cuts	81
Plank measure	27
Plan of a hip and common rafter in place	68
Plan of rafter	67
Plan of tower for windmill	149

	PAGE
Plans of hoppers	117
Plumb cut of rafter	42
Polygon family circle	209
Possibilities of the steel square	209
Prehistoric tools	19
Preliminary	15
Principles of hip roof framing	83
Principles of the diagonal scale	25
Projecting cornice	52
Rules, to find bevels of	90
Rules, to find shoulders of	85
Quick methods of finding hopper cuts.....	117
Quick methods of finding miter.....	138
Quick method of finding pitch.....	91
Rafters, laying out of	40-41
Rafters for acute roofs	43
Rafters, to find length of	53-63
Rafters, to find seat and plump cuts of	66
Rafter tables, etc	27-188
Reckoning by degrees	94
Regular miters	136
Requisites of the square	22
Return roof of a veranda	63
Reversed pitches	49
Revolving disk, the	188
Risers and treads	157
Riser shown in position	157
Roof drawing, use of square on	43
Roof for tower	54

INDEX

253

	PAGE
Roof framing	40
Roof, to timber a hexagon	115
Roof pitches explained	47
Rough stair strings	165
Rule for finding bevels for butt joint of hopper.	125
Rule for laying off octagons	31
Run of hip or valley, to find	59
Run of stairs, to determine	155
Saddle roofs.....	87
Scales on square explained	23
Scantling measure	27
Section of a raking mould	176
Shape and hip of rafters.....	63
Seat and plumb cuts of rafters.....	66
Shoulders of purlins, to find.....	85
Side cut of the hip.....	80
Side cut of hip and valley illustrated.	80-191
Side cut of jack illustrated.....	70-191
Side cut of octagon jack.....	191
Special features of new squares.....	27
Square hoppers.....	117
Square, how to test and true.....	22
Squares of inferior grade in use.....	32
Square used by earliest builders.....	19
Stair building	153
Stairs, illustrations of	165-167
Steel square, uses of	17-43
Steep roofs, how to frame.....	43
Strings, showing cuts for treads and risers..	155
Subject of degrees.....	187

	PAGE
Table of decimal equivalents.....	95
Table of tangents.....	191
Tangents and co-tangents.....	233
Testing a square.....	22
The finished workman.....	16
To cut bed moulds for gable.....	81
To cut common rafter.....	80
To cut planceer to run up valley.....	81
To find backing for a curved hip.....	61
To find backing of a hip rafter.....	83
To find bevels and width of hopper.....	118
To find bevels for butt joint of hopper.....	125
To find bevels for flared sides of hopper.....	126
To find cut for a butt joint.....	125
To find length of rafters where risers are of different height.....	53
To find shape of jack.....	208
To find the length of jacks.....	78
To timber a hexagon roof.....	115
To obtain length of various rafters for any width of building.....	106
Tools of prehistoric origin.....	19
Tower for windmill, etc.....	149
Tower roof, to obtain pitch of.....	54
Tread and riser, scheme for.....	161
Trusses, to obtain cuts and bevels of.....	146
Unequal pitches.....	74
Uneven pitches.....	50
Universal Square.....	183
Use of octagonal scale.....	31

INDEX

255

	PAGE
Use of square in following a roof drawing...	43
Use of the figures, lines and scales.....	23
Uses of the steel square.....	17
Valley rafter for gable.....	59
Valleys and hips.....	63
Valley, side cut of.....	70
Valleys, foot run for.....	71
Various views of hoppers.....	128
Wall string, finish of.....	170
What is needed to excel.....	14
Width of end of hopper.....	121
Windmill, diagram of tower for.....	149
Woods' illustration of roof pitches.....	91
Woods' Key to Steel Square.....	187

Practical House Plans

WE ILLUSTRATE IN THIS BOOK the perspective view and floor plans of 50 low and medium-priced houses. In the preparation of this work great care has been exercised in the selection of original, practical and attractive house designs, such as seventy-five to ninety per cent of the people to-day wish to build. In drawing these plans special effort has been made to provide for the MOST ECONOMICAL CONSTRUCTION, thereby giving the home builder and contractor the benefit of the saving of many dollars; for in no case have we put any useless expense upon the building simply to carry out some pet idea. Every plan illustrated will show, by the complete working plans and specifications, that we give you designs that will work out to the best advantage and will give you the most for your money; besides every bit of space has been utilized to the best advantage.

\$50.00 PLANS FOR ONLY \$5.00 This department has for its foundation the best equipped architectural establishment ever maintained for the purpose of furnishing the public with complete working plans and specifications at the remarkably low price of only \$5.00 per set. Every plan we illustrate has been designed by a licensed architect, who stands at the head of his profession in this particular class of work and has made a specialty of low and medium-priced houses. The price usually charged for this work is from \$50.00 to \$75.00.

WHAT WE GIVE YOU The first question you will ask is, "What do we get in these complete working plans and specifications? Of what do they

consist? Are they the cheap printed plans on tissue paper without details or specifications?" We do not blame you for wishing to know what you will get for your money.

BLUE PRINTED WORKING PLANS The plans we send out are the regular blue printed plans, drawn one-quarter inch scale to the foot, showing all the elevations, floor plans and necessary interior details. All of our plans are printed by electricity on an electric circular blue-printing machine, and we use the very best grade of electric blue-printing paper; every line and figure showing perfect and distinct.

FOUNDATION AND CELLAR PLANS This sheet shows the shape and size of all walls, piers, footings, posts, etc., and of what materials they are constructed; shows the location of all windows, doors, chimneys, ash-pits, partitions, and the like. The different wall sections are given, showing their construction and measurements from all the different points.

FLOOR PLANS These plans show the shape and size of all rooms, halls and closets; the location and size of all doors and windows; the position of all plumbing fixtures, gas lights, registers, pantry work, etc., and all the measurements that are necessary are given.

ELEVATIONS A front, right, left and rear elevation are furnished with all the plans. These drawings are complete and accurate in every respect. They show the shape, size and location of all doors, windows, porches, cornices, towers, bays, and the like; in fact, give you an exact scale picture of the house as it should be at completion. Full wall sections are given showing the construction from foundation to roof, the height of stories between the joists, height of plates, pitch of roof, etc.

ROOF PLAN This plan is furnished where the roof construction is at all intricate. It shows the location of all hips, valleys, ridges, decks, etc. All the above drawings are made to scale one-quarter inch to the foot.

DETAILS All necessary details of the interior work, such as door and window casings and trim, base, stools, picture moulding, doors, newel posts, balusters, rails, etc., accompany each set of plans. Part is shown in full size, while some of the larger work, such as stair construction, is drawn to a scale of one and one-half inch to the foot. These blue prints are substantially and artistically bound in cloth and heavy water-proof paper, making a handsome and durable covering and protection for the plans.

SPECIFICATIONS The specifications are typewritten on Lakeside Bond Linen paper and are bound in the same artistic manner as the plans, the same cloth and water-proof paper being used. They consist of from about sixteen to twenty pages of closely typewritten matter, giving full instructions for carrying out the work. All directions necessary are given in the clearest and most explicit manner, so that there can be no possibility of a misunderstanding.

BASIS OF CONTRACT The working plans and specifications we furnish can be made the basis of contract between the home builder and the contractor. This will prevent mistakes, which cost money, and they will prevent disputes which are unforeseen and never settled satisfactorily to both parties. When no plans are used the contractor is often obliged to do some work he did not figure on, and the home builder often does not get as much for his money as he expected, simply because there was no basis on which to work and upon which to base the contract.

NO MISUNDERSTANDING CAN ARISE when a set of our plans and specifications is furnished to the contractor and the home builder, showing the exact and entire construction of the house as intended in the contract. Many advantages may be secured from the complete plans and specifications. They save the contractor and, therefore, money savers. Workmen do not wait for instructions when a set of plans is furnished to them. They will prevent mistakes in cutting lumber for doors and window frames, and in many other places where the contractor is not on the work and the men are given only partial or indefinite instructions. They also give instructions for the working of all material to the best advantage.

FREE PLANS FOR FIRE INSURANCE ADJUSTMENT You take every precaution to have your house covered by insurance; but do you make any provision for the adjustment of the loss, should you have a fire? There is not one man in ten thousand who will provide for this embarrassing situation. You can call to mind instances in your own locality where settlements have been delayed because the insurance companies wanted some proof which could not be furnished. They demand proof of loss before paying insurance money, and they are entitled to it. We have provided for this and have inaugurated the following plan, which cannot but meet with favor by whoever builds a house from our plans.

IMMEDIATELY UPON RECEIPT OF INFORMATION from you that your house has been destroyed by fire, either totally or partially, we will forward you, free of cost, a duplicate set of plans and specifications, and in addition we will furnish an affidavit giving the number of the design and the date when furnished, to be used for the adjustment of the insurance.

WITHOUT ONE CENT OF COST TO YOU and without one particle of trouble. We keep a record of the number of the house design and the date it was furnished, so that, in time of loss, all it will be necessary for you to do is to drop us a line and we will furnish the only reliable method of getting a speedy and satisfactory adjustment. This may be the means of saving you hundreds of dollars, besides much time and worry.

OUR LIBERAL PRICES Many have marveled at our ability to furnish such excellent and complete working plans and specifications at such low prices. We do not wonder at this, because we charge but \$5.00 for a more complete set of working plans and specifications than you would receive if ordered in the ordinary manner, and when drawn especially for you, at a cost of from fifty to seventy-five dollars. On account of our large business and unusual equipment, and owing to the fact that WE DIVIDE THE COST of these plans among so many, it is possible for us to sell them at these low prices. The margin of profit is very close, but it enables us to sell thousands of sets of plans, which save many times their cost to both the owner and the contractor in erecting even the smallest dwelling.

OUR GUARANTEE Perhaps there are many who feel that they are running some risk in ordering plans at a distance. We wish to assure our customers that there is no risk whatever. If, upon receipt of these plans, you do not find them exactly as represented, if you do not find them complete and accurate in every respect, if you do not find them as well prepared as those furnished by any architect in the country, or any that you have ever seen, we will refund your money upon the return of the plans from you in perfect condition. All of our plans are prepared by architects standing at the head of their profession, and

the standard of their work is the very highest. We could not afford to make this guarantee if we were not positive that we were furnishing the best plans put out in this country, even though our price is not more than one-seventh to one-tenth of the price usually charged.

BILL OF MATERIAL We do not furnish a bill of material. We state this here particularly, as some people have an idea that a bill of material should accompany each set of plans and specifications. In the first place, our plans are gotten up in a very comprehensive manner, so that any carpenter can easily take off the bill of material without any difficulty. We realize that there are hardly two sections of the country where exactly the same kinds of materials are used, and, moreover, a bill which we might furnish would not be applicable in all sections of the country. We furnish plans and specifications for houses which are built as far north as the Hudson Bay and as far south as the Gulf of Mexico. They are built upon the Atlantic and Pacific Coasts, and you can also find them in Australia and South Africa. Each country and section of a country has its peculiarities as to sizes and qualities; therefore, it would be useless for us to make a list that would not be universal. Our houses, when completed, may look the same whether they are built in Canada or Florida, but the same materials will not be used, for the reason that the customs of the people and the climatic conditions will dictate the kind and amount of materials to be used in their construction.

ESTIMATED COST It is impossible for anyone to estimate the cost of a building and have the figures hold good in all sections of the country. We do not claim to be able to do it. The estimated cost of the houses we illustrate is based on the most favorable conditions in all respects and includes everything but the plumbing and

heating. We are not familiar with your local conditions, and, should we claim to know the exact cost of a building in your locality, a child would know that our statement was false. We leave this matter in the hands of the reliable contractors, for they, and they alone, know your local conditions.

WE WISH TO BE FRANK WITH YOU and therefore make no statement that we cannot substantiate in every respect. If a plan in this book pleases you; if the arrangement of the rooms is satisfactory, and if the exterior is pleasing and attractive, then we make this claim—that it can be built as cheaply as if any other architect designed it, and we believe cheaper.

WE HAVE STUDIED ECONOMY in construction, and our knowledge of all the material that goes into a house qualifies us to give you the best for your money. We give you a plan that pleases you, one that is attractive, and one where every foot of space is utilized at the least possible cost. Can any architect do more, even at seven to ten times the price we charge you for plans?

REVERSING PLANS We receive many requests from our patrons for plans exactly according to the designs illustrated, with the one exception of having them reversed or placed in the opposite direction. It is impossible for us to make this change and draw new plans, except at a cost of about eight times our regular price. We see no reason why our regular plans will not answer your purpose. Your carpenter can face the house exactly as you wish it, and the plans will work out as well facing in one direction as in another. We can, however, if you wish, and so instruct us, make you a reversed blue print and

furnish it at our regular price; but in that case all the figures and letters will be reversed and, therefore, liable to cause as much confusion as if your carpenter reversed the plan himself while constructing the house.

WE WOULD ADVISE however, in all cases where the plan is to be reversed, and there is the least doubt about the contractor not being able to work from the plans as we have them, that two sets of blue prints be purchased, one regular and the other reversed, and in such cases we will furnish two sets of blue prints and one set of specifications for only fifty per cent added to the regular cost, making the \$5.00 plan cost only \$7.50.





Design No. 1546

PRICE
of Blue
Prints, to-
gether with
a complete
set of type-
written
specifica-
tions is

ONLY
\$5.00

They save
time and
prevent
waste of
material

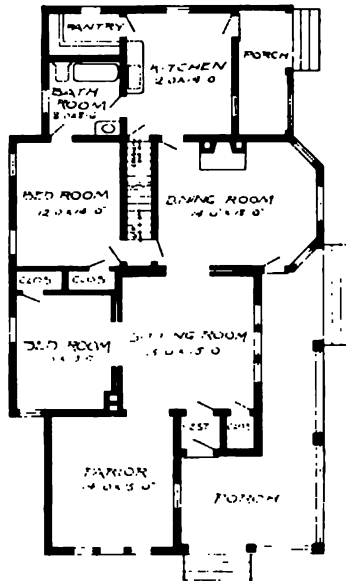

Floor Plan

Size: Width, 35 feet; length, 61 feet

Blue prints consist of cellar and foundation plan; roof plan; floor plan; front, rear, two side elevations; wall sections and all necessary interior details. Specifications consist of about twenty pages of typewritten matter.

Full and complete working plans and specifications of this house will be furnished for \$5.00. Cost of this house is from about \$1,500.00 to about \$1,700.00, according to the locality in which it is built.



Design No. 1545



First Floor Plan



Second Floor Plan

Size: Width, 46 feet 3 inches; length, 24 feet 6 inches

Blue prints consist of cellar and foundation plan; roof plan; first and second floor plans; front, rear, two side elevations; wall sections and all necessary interior details. Specifications consist of about twenty-five pages of typewritten matter.

Full and complete working plans and specifications of this house will be furnished for \$15.00. Cost of this house is from about \$3,850.00 to about \$4,100.00, according to the locality in which it is built.

PRICE
of Blue Prints, together with a complete set of typewritten specifications is

ONLY
\$15.00

They save time and prevent waste of material.



Design No. 1506

PRICE
of Blue
Prints, to-
gether with
a complete
set of type-
written
specifica-
tions is
ONLY
\$5.00

They save
time and
prevent
waste of
material



First Floor Plan

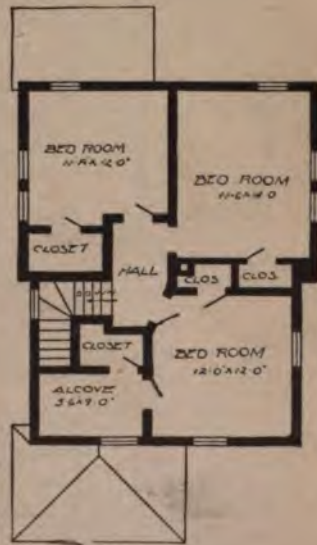

Second Floor Plan

Size: Width, 22 feet 6 inches; length, 30 feet, exclusive of porches

Blue prints consist of cellar and foundation plan; first and second floor plans; front, rear, two side elevations; wall sections and all necessary interior details. Specifications consist of about twenty pages of typewritten matter.

Full and complete working plans and specifications of this house will be furnished for \$5.00. Cost of this house is from about \$850.00 to about \$1,000.00, according to the locality in which it is built.



Design No. 1535



First Floor Plan

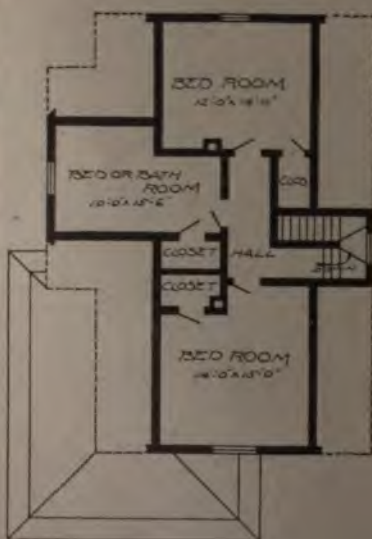

Second Floor Plan

Size; Width, 30 feet; length, 46 feet, exclusive of porches

Blue prints consist of foundation plan; roof plan; first and second floor plans; front, rear, two side elevations; wall sections and all necessary interior details. Specifications consist of about twenty pages of typewritten matter.

Full and complete working plans and specifications of this house will be furnished for \$5.00. Cost of this house is from about \$1,550.00 to about \$1,700.00, according to the locality in which it is built.

PRICE
of Blue
Prints, to-
gether with
a complete
set of type-
written
specifica-
tions is
ONLY
\$5.00

They save
time and
prevent
waste of
material



Design No. 1554

PRICE
of Blue
Prints, to-
gether with
a complete
set of type-
written
specifica-
tions is

ONLY
\$5.00

They save
time and
prevent
waste of
material



First Floor Plan



Second Floor Plan

Size: Width, 26 feet 6 inches; length, 45 feet 6 inches, exclusive of porches

Blue prints consist of cellar and foundation plan; roof plan; first and second floor plans; front, rear, two side elevations; wall sections and all necessary interior details. Specifications consist of about twenty pages of typewritten matter.

Full and complete working plans and specifications of this house will be furnished for \$5.00. Cost of this house is from about \$1,150.00 to about \$1,350.00, according to the locality in which it is built.



Design No. 1564



First Floor Plan



Second Floor Plan

Size; Width, 25 feet 8 inches; length, 32 feet 8 inches, exclusive of porches

Blue prints consist of collar and foundation plan; roof plan; first and second floor plans; front, rear, two side elevations; wall sections and all necessary interior details. Specifications consist of about twenty pages of typewritten matter.

Full and complete working plans and specifications of this house will be furnished for \$5.00. Cost of this house is from about 1,600.00 to about \$1,850.00, according to the locality in which it is built.

PRICE

of Blue Prints, together with a complete set of type-written specifications is

ONLY

\$5.00

They save time and prevent waste of material



Design No. 1502

PRICE
of Blue
Prints, to-
gether with
a complete
set of type-
written
specifica-
tions is
ONLY
\$5.00

They save
time and
prevent
waste of
material



First Floor Plan



Second Floor Plan

Size: Width, 22 feet; length, 38 feet, exclusive of porches

Blue prints consist of cellar and foundation plan; roof plan; first and second floor plans; front, rear, two side elevations; wall sections and all necessary interior details. Specifications consist of about twenty pages of typewritten matter.

Full and complete working plans and specifications of this house will be furnished for \$5.00. Cost of this house is from about \$1,400.00 to about \$1,625.00, according to the locality in which it is built.



Design No. 1521

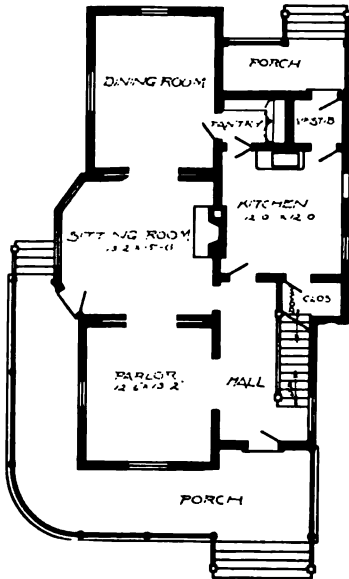

First Floor Plan

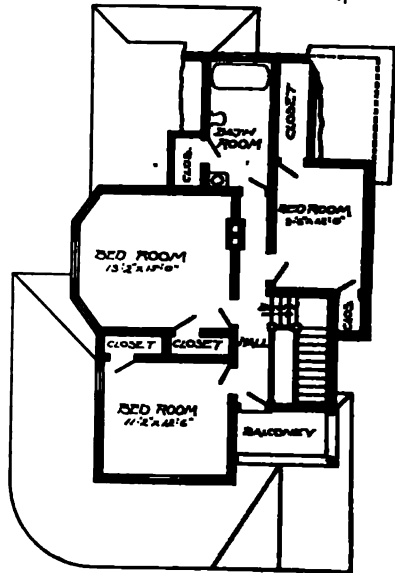

Second Floor Plan

Size: Width, 26 feet; length, 44 feet 4 inches, exclusive of porches

Blue prints consist of cellar and foundation plan; first and second floor plans; front, rear, two side elevations; wall sections and all necessary interior details. Specifications consist of about twenty pages of typewritten matter.

Full and complete working plans and specifications of this house will be furnished for \$5.00. Cost of this house is from about \$1,800.00 to about \$2,000.00, according to the locality to which it is built.

PRICE
of Blue
Prints,
gathered
a complete
set of typewritten
specifications
is

ONLY
\$5.00

They save
time and
prevent
waste of
material



G. W. ASHBY ARCH.

Design No. 1530

PRICE

of Blue Prints, together with a complete set of typewritten specifications is

ONLY

\$5.00

They save time and prevent waste of material

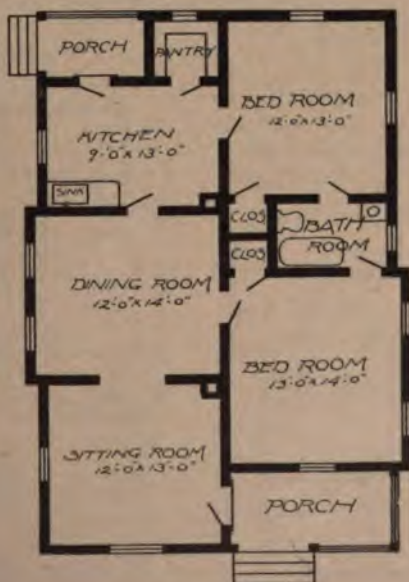

Floor Plan

Size: Width, 28 feet 6 inches; length, 40 feet

Blue prints consist of foundation plan; roof plan; floor plan; front, rear, two side elevations; wall sections and all necessary interior details. Specifications consist of about fifteen pages of typewritten matter.

Full and complete working plans and specifications of this house will be furnished for \$5.00. Cost of this house is from about \$900.00 to about \$1,100.00, according to the locality in which it is built.



Design No. 1559

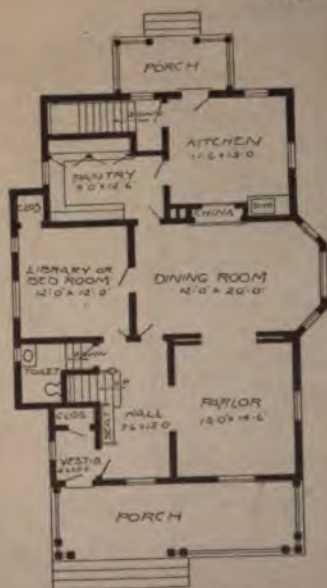

First Floor Plan



Second Floor Plan

Size: Width, 34 feet; length, 42 feet, exclusive of porches

Blue prints consist of cellar and foundation plan; roof plan; first and second floor plans; front, rear, two side elevations; wall sections and all necessary interior details. Specifications consist of about twenty pages of typewritten matter.

Full and complete working plans and specifications of this house will be furnished for \$12.00. Cost of this house is from about \$2,350.00 to about \$2,700.00, according to the locality in which it is built.

PRICE
of Blue Prints, together with a complete set of typewritten specifications is

ONLY \$12.00

They save time and prevent waste of material



Design No. 1510

PRICE
of Blue
Prints, to-
gether with
a complete
set of type-
written
specifica-
tions is

ONLY
\$5.00

They save
time and
prevent
waste of
material

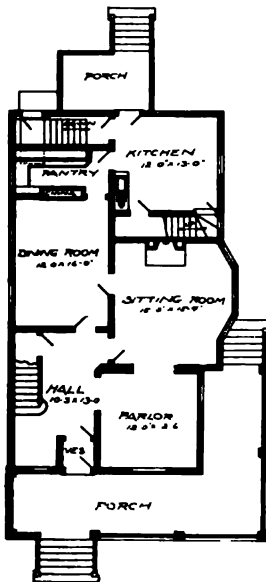

First Floor Plan

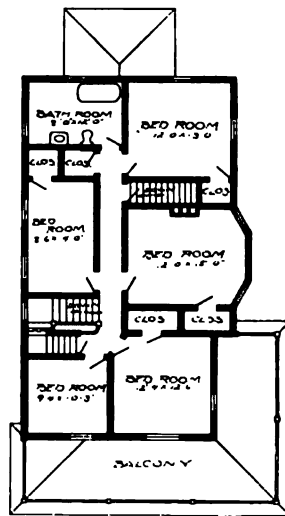

Second Floor Plan

Size: Width, 26 feet 10 inches; length, 45 feet 2 inches, exclusive of porches

Blue prints consist of cellar and foundation plan; roof plan; first and second floor plans; front, rear, two side elevations; wall sections and all necessary interior details. Specifications consist of about twenty pages of typewritten matter.

Full and complete working plans and specifications of this house will be furnished for \$5.00. Cost of this house is from about \$2,500.00 to about \$2,750.00, according to the locality in which it is built.



Design No. 1525

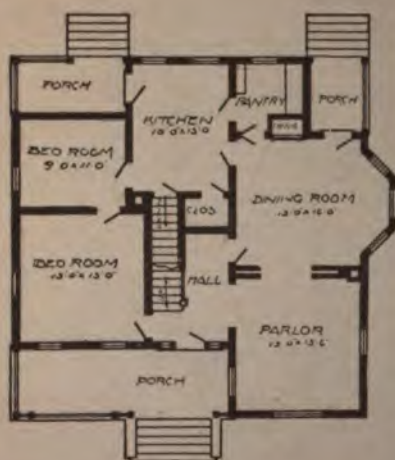

First Floor Plan

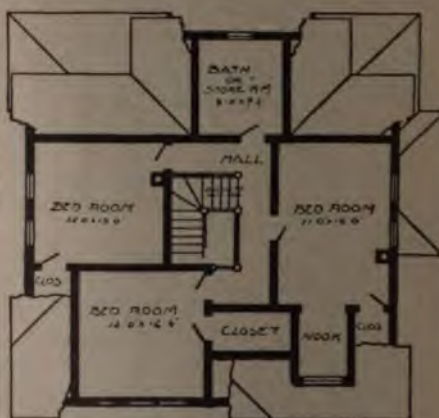

Second Floor Plan

Size: Width, 36 ft; length, 36 feet

Blue prints consist of cellar and foundation plan; first and second floor plans; front, rear, two side elevations; wall sections and all necessary interior details. Specifications consist of about twenty pages of typewritten matter.

Full and complete working plans and specifications of this house will be furnished for \$5.00. Cost of this house is from about \$1,525.00 to about \$1,775.00, according to the locality in which it is built.



Design No. 1537

PRICE
of Blue
Prints, to-
gether with
a complete
set of type-
written
specifica-
tions is

ONLY
\$3.00

They save
time and
prevent
waste of
material



Floor Plan

Size: Width, 16 feet; length, 25 feet 6 inches, exclusive of porches

Blue prints consist of foundation plan; floor plan; front, rear, two side elevations; wall sections and all necessary interior details. Specifications consist of about twelve pages of typewritten matter.

Full and complete working plans and specifications of this house will be furnished for \$3.00. Cost of this house is from about \$400.00 to about \$450.00, according to the locality in which it is built.



Design No. 1553

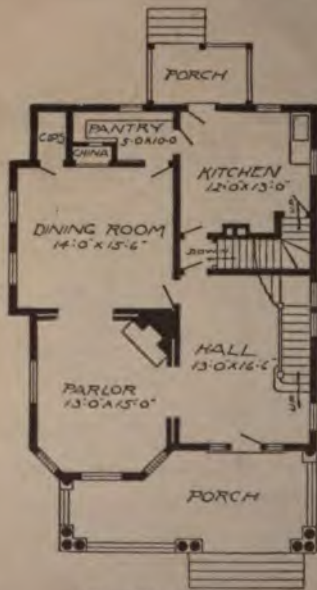

First Floor Plan



Second Floor Plan

Size: Width, 30 feet; length, 36 feet 6 inches, exclusive of porches

Blue prints consist of cellar and foundation plan; roof plan; first and second floor plans; front, rear, two side elevations; wall sections and all necessary interior details. Specifications consist of about twenty pages of typewritten matter.

Full and complete working plans and specifications of this house will be furnished for \$5.00. Cost of this house is from about \$1,700.00 to about \$1,900.00, according to the locality in which it is built.

PRICE
of Blue
Prints, to-
gether with
a complete
set of type-
written
specifica-
tions is
ONLY
\$5.00

They save
time and
prevent
waste of
material



Design No. 1507

PRICE
of Blue
Prints, together with
a complete
set of type-
written
specifica-
tions is
ONLY
\$5.00

They save
time and
prevent
waste of
material



First Floor Plan

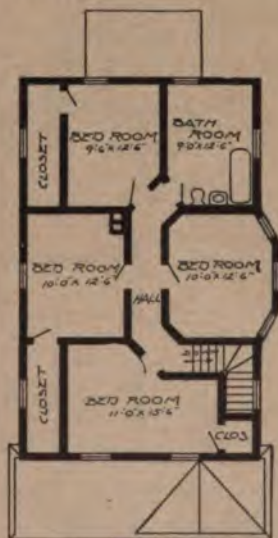

Second Floor Plan

Size: Width, 24 feet; length, 38 feet, exclusive of porches

Blue prints consist of cellar and foundation plan; roof plan first and second floor plans; front, rear, two side elevations; wall sections and all necessary interior details. Specifications consist of about twenty pages of typewritten matter.

Full and complete working plans and specifications of this house will be furnished for \$5.00. Cost of this house is from about \$1,425.00 to about \$1,575.00, according to the locality in which it is built.



Design No. 1505



First Floor Plan



Second Floor Plan

Size: Width, 25 feet 6 inches; length, 29 feet 6 inches, exclusive of porches

Blue prints consist of cellar and foundation plan; first and second floor plans; front, rear, two side elevations; wall sections and all necessary interior details. Specifications consist of about twenty pages of typewritten matter.

Full and complete working plans and specifications of this house will be furnished for \$5.00. Cost of this house is from about \$875.00 to about \$1,100.00, according to the locality in which it is built.

PRICE
of Blue-Prints, together with a complete set of typewritten specifications is
ONLY \$5.00

They save time and prevent waste of material



Design No. 1501

PRICE
of Blue Prints, together with a complete set of type-written specifications is
ONLY \$5.00
They save time and prevent waste of material



First Floor Plan

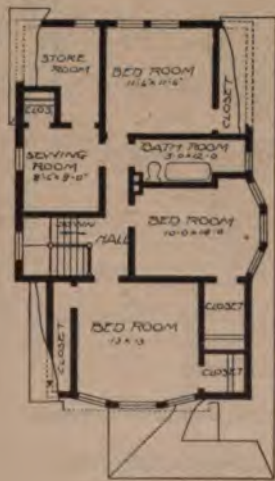

Second Floor Plan

Size: Width, 26 feet; length, 41 feet, exclusive of porches

Blue prints consist of cellar and foundation plan; roof plan; first and second floor plans; front, rear, two side elevations; wall sections and all necessary interior details. Specifications consist of about twenty pages of typewritten matter.

Full and complete working plans and specifications of this house will be furnished for \$5.00. Cost of this house is from about \$1,650.00 to about \$1,875.00, according to the locality in which it is built.



Design No. 1560

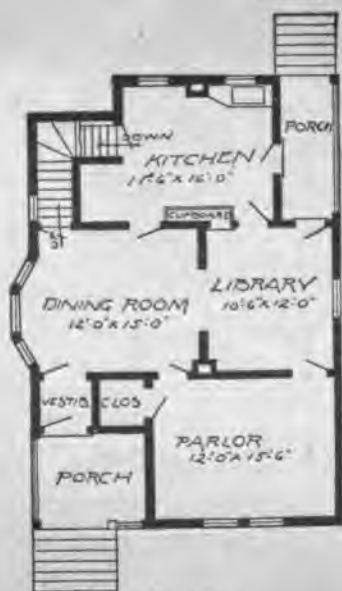

First Floor Plan

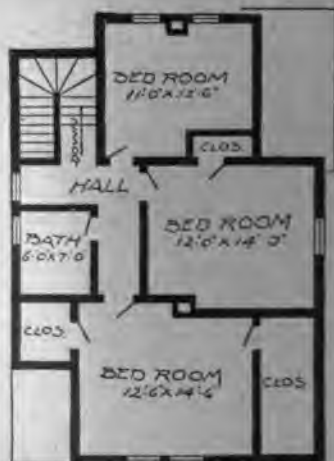

Second Floor Plan

Size: Width, 26 feet; length, 38 feet

Blue prints consist of cellar and foundation plan; roof plan; first and second floor plans; front, rear, two side elevations, wall sections and all necessary interior details. Specifications consist of about twenty pages of typewritten matter.

Full and complete working plans and specifications of this house will be furnished for \$5.00. Cost of this house is from about \$750.00 to about \$900.00, according to the locality to which it is built.

PRICE
of Blue
Prints, to
get the
a complete
set of 17
written
specifica-
tions is

ONLY
\$5.00

They save
time and
prevent
waste of
material



Design No. 1566

E
o-
ith
te
pe-

Y
10
ve
1
1

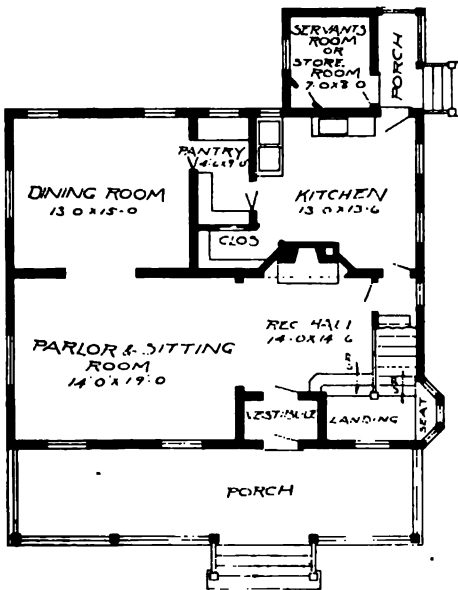

First Floor Plan

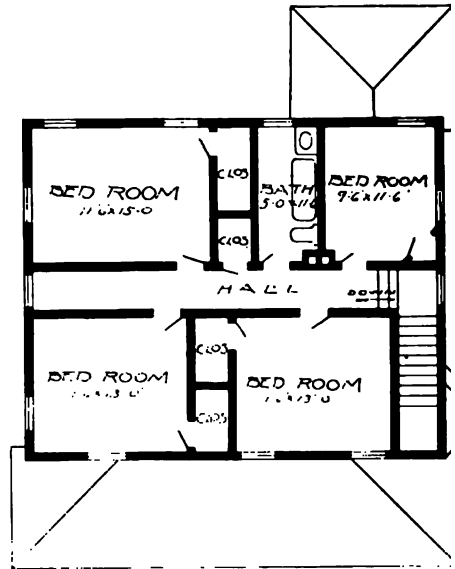

Second Floor Plan

Size: Width, 35 feet; length, 28 feet 6 inches, exclusive of porches

Blue prints consist of cellar and foundation plan; roof plan; first and second floor plans; front, rear, two side elevations; wall sections and all necessary interior details. Specifications consist of about twenty pages of typewritten matter.

Full and complete working plans and specifications of this house will be furnished for \$5.00. Cost of this house is from about \$1,950.00 to about \$2,200.00, according to the locality in which it is built.



Design No. 1561

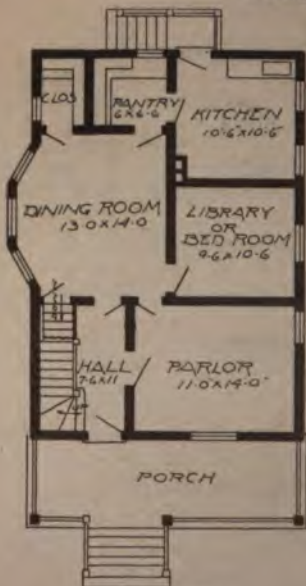

First Floor Plan



Second Floor Plan

Size: Width, 23 feet; length, 33 feet, exclusive of porches

Blue prints consist of cellar and foundation plan; roof plan; first and second floor plans; front, rear, two side elevations; wall sections and all necessary interior details. Specifications consist of about twenty pages of typewritten matter.

Full and complete working plans and specifications of this house will be furnished for \$5.00. Cost of this house is from about \$1,200.00 to about \$1,400.00, according to the locality in which it is built.

PRICE

of Blue Prints, together with a complete set of typewritten specifications is

ONLY
\$5.00

They save time and prevent waste of material



Design No. 1522

PRICE
of Blue
Prints, to-
gether with
a complete
set of type-
written
specifica-
tions is

ONLY
\$5.00

They save
time and
prevent
waste of
material.

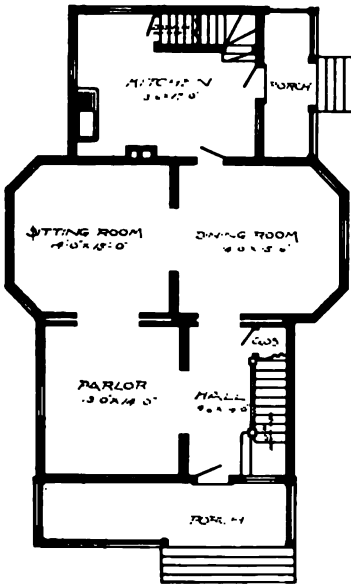

First Floor Plan

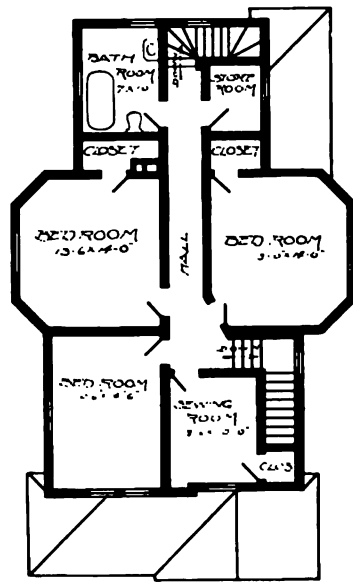

Second Floor Plan

Size: Width, 32 feet; length, 44 feet, exclusive of porch

Blue prints consist of cellar and foundation plan; roof plan; first and second floor plans; front, rear, two side elevations; wall sections and all necessary interior details. Specifications consist of about twenty pages of typewritten matter.

Full and complete working plans and specifications of this house will be furnished for \$5.00. Cost of this house is from about \$1,400.00 to about \$2,000.00, according to the locality in which it is built.



Design No. 1107

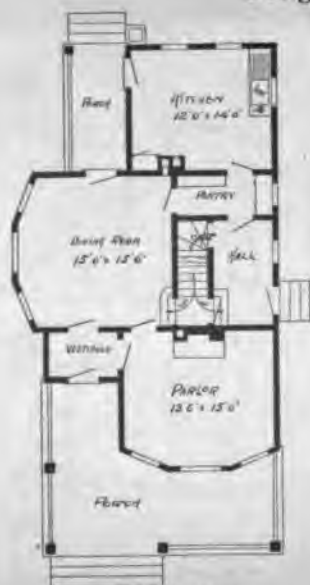

First Floor Plan

Size: Width, 26 feet 6 inches; length, 42 feet 6 inches, exclusive of porch

Blue prints consist of cellar and foundation plan; first and second floor plans; front, rear, two side elevations; wall sections and all necessary interior details. Specifications consist of about fifteen pages of typewritten matter.

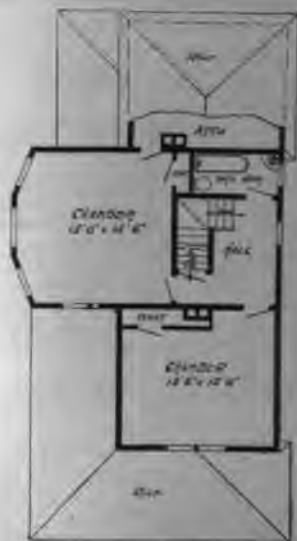

Second Floor Plan

Full and complete working plans and specifications of this house will be furnished for \$5.00. Cost of this house is from about \$1,250.00 to about \$1,450.00, according to the locality in which it is built.

PRICE
of Blue
Prints, 5
copies of
a complete
set of typewritten
specifications is

ONLY
\$5.00

They save
time and
prevent
waste of
material!



Design No. 1519

ICE
 e
 s, 10-
 r with
 plete
 type-
 en
 sca-
 is
 ILY
 .00
 save
 and
 ent
 of
 rial.

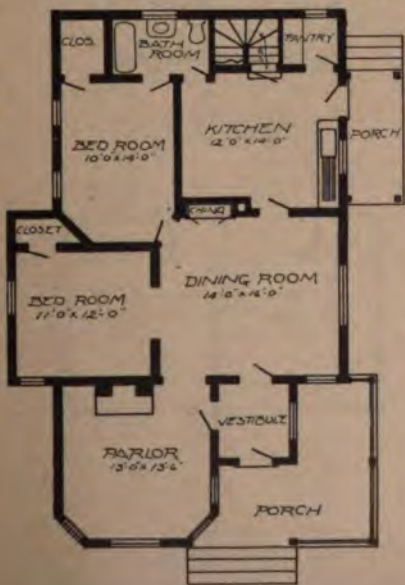

First Floor Plan

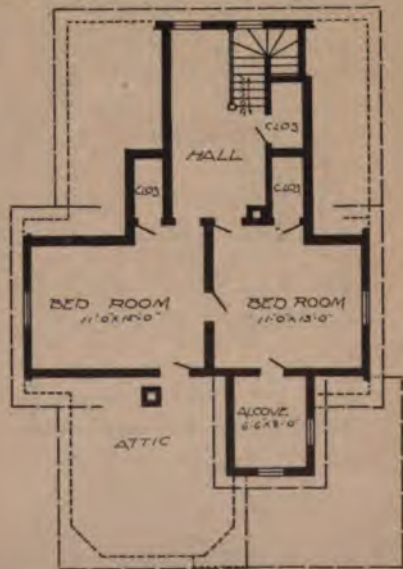

Second Floor Plan

Size: Width, 29 feet 6 inches; length, 46 feet, exclusive of porches

Blue prints consist of cellar and foundation plan; roof plan; first and second floor plans; front, rear, two sides elevations; wall sections and all necessary interior details. Specifications consist of about twenty pages of typewritten matter.

Full and complete working plans and specifications of this house will be furnished for \$5.00. Cost of this house is from about \$1,850.00 to about \$2,000.00, according to the locality in which it is built.



Design No. 1503

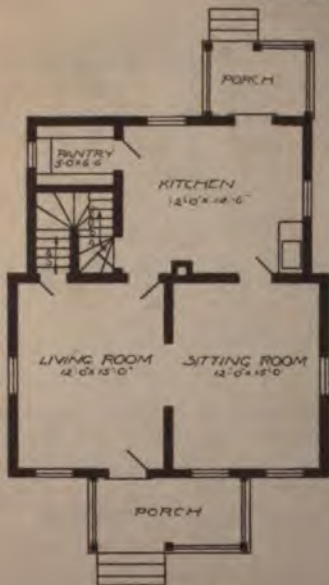

First Floor Plan

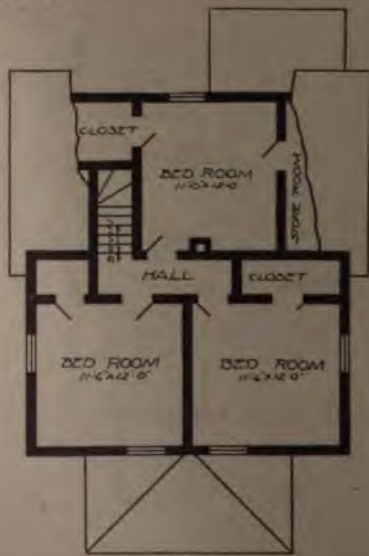

Second Floor Plan

Size: Width, 25 feet 6 inches; length, 28 feet 6 inches, exclusive of porches

Blue prints consist of cellar and foundation plan; first and second floor plans; front, rear, two side elevations; wall sections and all necessary interior details. Specifications consist of about twenty pages of typewritten matter.

Full and complete working plans and specifications of this house will be furnished for \$5.00. Cost of this house is from about \$850.00 to about \$1,050.00, according to the locality in which it is built.

PRICE
of Blue
Prints, to-
gether with
a complete
set of type-
written
specifica-
tions is
ONLY
\$5.00
They save
time and
prevent
waste of
material



Design No. 1569

PRICE

of Blue Prints, together with a complete set of type-written specifications is

ONLY

\$15.00

They save time and prevent waste of material



First Floor Plan

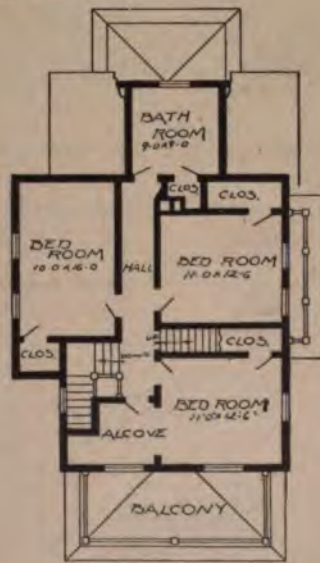

Second Floor Plan

Size: Width, 30 feet; length, 39 feet 6 inches, exclusive of porches

Blue prints consist of cellar and foundation plan; roof plan; first and second floor plans; front, rear, two side elevations; wall sections and all necessary interior details. Specifications consist of about 25 pages of typewritten matter.

Full and complete working plans and specifications of this house will be furnished for \$15.00. Cost of this house is from about \$3,000.00 to about \$3,250.00, according to the locality in which it is built.



Design No. 1565

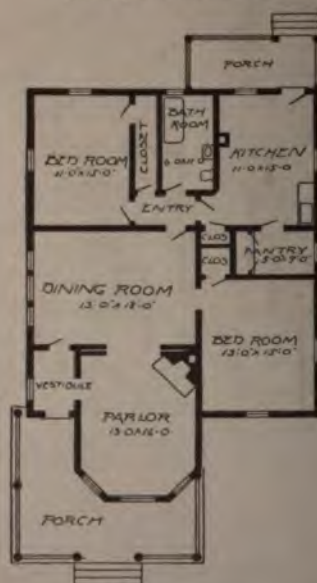

Floor Plan

Size: Width, 33 feet; length, 46 feet 6 inches, exclusive of porches

Blue prints consist of foundation plan; roof plan; floor plan; front, rear, two side elevations; wall sections and all necessary interior details. Specifications consist of about fifteen pages of typewritten matter.

PRICE

of Blue Prints, together with a complete set of type-written specifications is

**ONLY
\$5.00**

They save time and prevent waste of material

Full and complete working plans and specifications of this house will be furnished for \$5.00. Cost of this house is from about \$1,100.00 to about \$1,250.00, according to the locality in which it is built.



Design No. 1547

CE
to-
with
ete
rpe-
s-
Y
00
ve
d
r
l

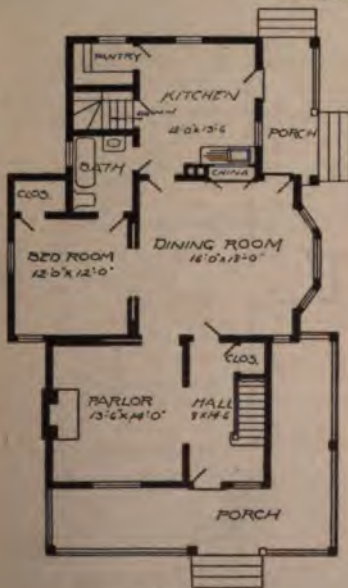

First Floor Plan

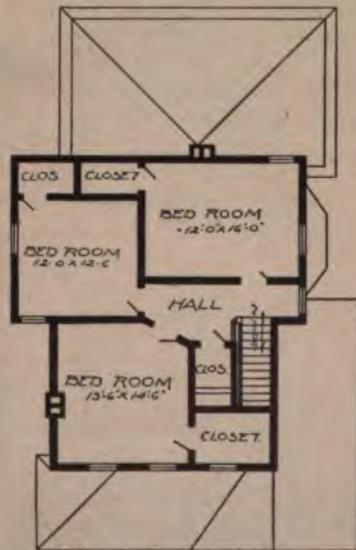

Second Floor Plan

Size: Width, 32 feet; length, 46 feet, exclusive of porches

Blue prints consist of cellar and foundation plan; roof plan; first and second floor plans; front, rear, two side elevations; wall sections and all necessary interior details. Specifications consist of about twenty pages of typewritten matter.

Full and complete working plans and specifications of this house will be furnished for \$5.00. Cost of this house is from about \$1,650.00 to about \$1,800.00, according to the locality in which it is built.



Design No. 1563

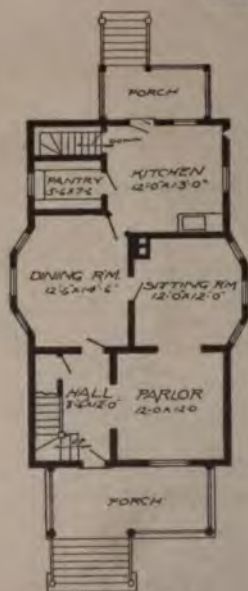

First Floor Plan

Size: Width, 26 feet; length, 38 feet, exclusive of porches

Blue prints consist of cellar and foundation plan; roof plan; first and second floor plans; front, rear, two side elevations; wall sections and all necessary interior details. Specifications consist of about twenty pages of typewritten matter.

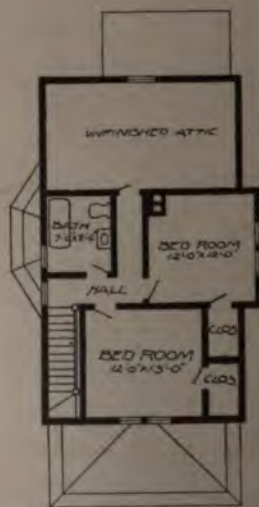

Second Floor Plan

Full and complete working plans and specifications of this house will be furnished for \$5.00. Cost of this house is from about \$1,200.00 to about \$1,400.00, according to the locality in which it is built.

PRICE

of Blue Prints, together with a complete set of typewritten specifications is

ONLY

\$5.00

They save time and prevent waste of material



Design No. 1538

PRICE
of Blue
Prints, to-
gether with
a complete
set of type-
written
specifica-
tions is

ONLY
\$5.00

They save
time and
prevent
waste of
material

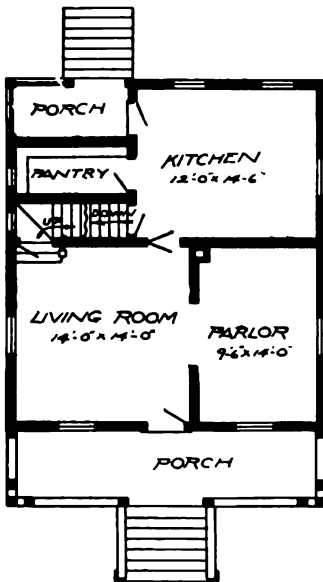

First Floor Plan

Size: Width, 25 feet; length, 33 feet 6 inches, exclusive of porch

Blue prints consist of cellar and foundation plan; roof plan; first and second floor plans; front, rear, two side elevations; wall sections and all necessary interior details. Specifications consist of about twenty pages of typewritten matter.

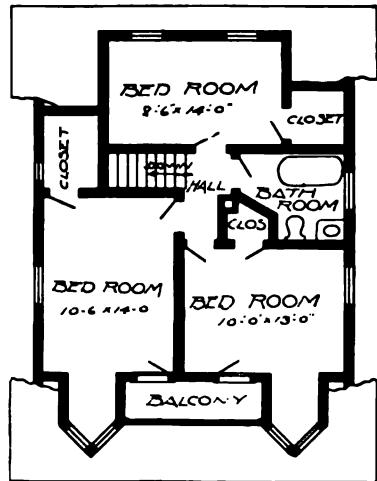

Second Floor Plan

Full and complete working plans and specifications of this house will be furnished for \$5.00. Cost of this house is from about \$1,775.00 to about \$1,975.00, according to the locality in which it is built.



Design No. 1551

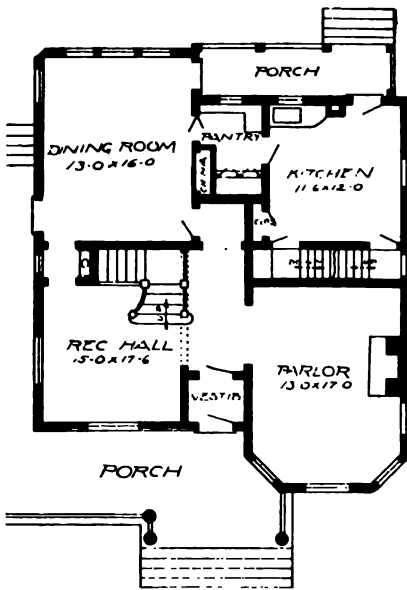

First Floor Plan

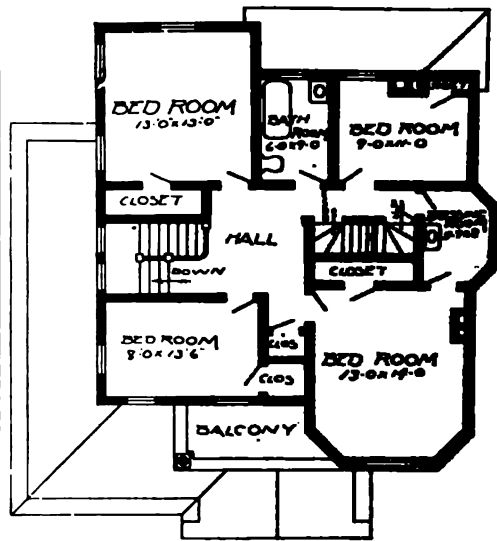

Second Floor Plan

Size: Width, 32 feet; length, 38 feet, exclusive of porches

Blue prints consist of cellar and foundation plan; roof plan; first and second floor plans; front, rear, two side elevations; wall sections and all necessary interior details. Specifications consist of about twenty-five pages of typewritten matter.

Full and complete working plans and specifications of this house will be furnished for \$5.00. Cost of this house is from about \$2,200.00 to about \$2,450.00, according to the locality in which it is built.

Pl
of B
Prin
gath
a co
set
with
spec
tion

G
\$1

The
prev
was
made



Design No. 1549

PRICE

ue
ta, 10-
er with
mplete
f type-
en
ffica-
is

ONLY
0.00

save
and
ent
e of
rial

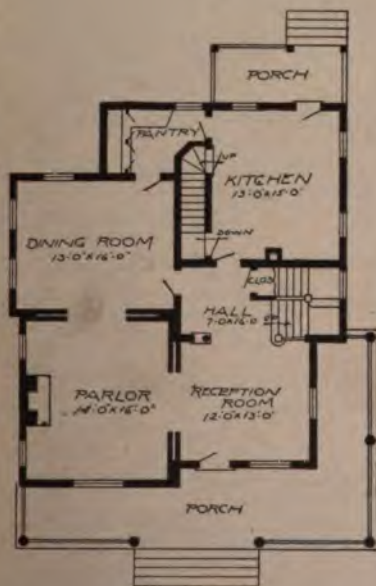

First Floor Plan

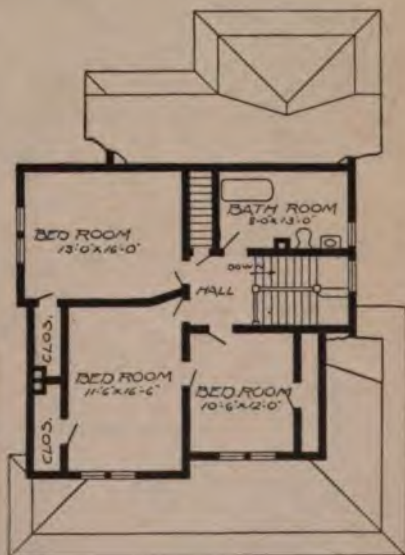

Second Floor Plan

Size: Width, 33 feet 6 inches; length, 38 feet, exclusive of porches

Blue prints consist of cellar and foundation plan; roof plan; first and second floor plans; front, rear, two side elevations; wall sections and all necessary interior details. Specifications consist of about twenty-five pages of typewritten matter.

Full and complete working plans and specifications of this house will be furnished for \$5.00. Cost of this house is from about \$2,150.00 to about \$2,350.00, according to the locality in which it is built.



Design No. 1527

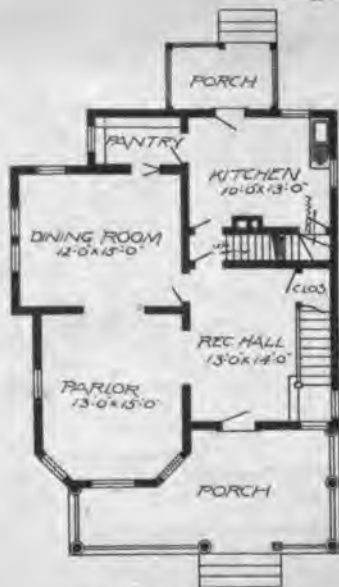

First Floor Plan

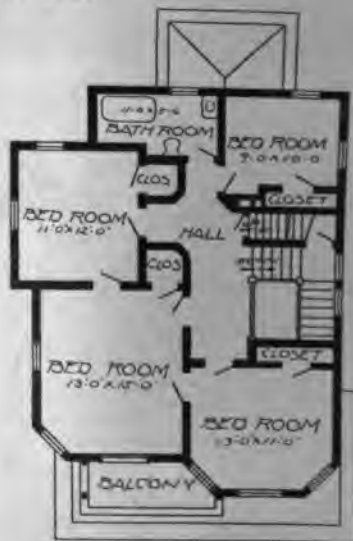

Second Floor Plan

Size: Width, 29 feet 6 inches; length, 33 feet 6 inches, exclusive of porches

Blue prints consist of cellar and foundation plan; roof plan; first and second floor plans; front, rear, two side elevations; wall sections and all necessary interior details. Specifications consist of about twenty pages of typewritten matter.

Full and complete working plans and specifications of this house will be furnished for \$5.00. Cost of this house is from about \$1,800.00 to about \$2,000.00, according to the locality in which it is built.

PRICE
of Blue
Prints, to
gether with
a complete
set of typewritten
specifications is
ONLY
\$5.00
They save
time and
prevent
waste of
material



Design No. 1557

PRICE
of Blue
Prints, to-
gether with
a complete
set of type-
written
specifica-
tions is

ONLY
\$5.00

They save
time and
prevent
waste of
material



Floor Plan

Size: Width, 28 feet 6 inches; length, 46 feet 6 inches, exclusive of porches

Blue prints consist of foundation plan; roof plan; floor plan; front, rear, two side elevations; wall sections and all necessary interior details. Specifications consist of about fifteen pages of typewritten matter.

Full and complete working plans and specifications of this house will be furnished for \$5.00. Cost of this house is from about \$1,150.00 to about \$1,300.00, according to the locality in which it is built.



Design No. 1516

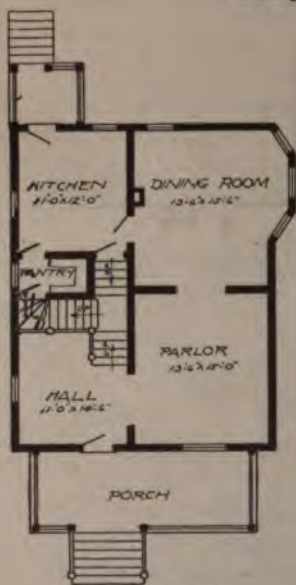

First Floor Plan



Second Floor Plan

Size: Width, 26 feet; length, 32 feet, exclusive of porches

Blue prints consist of cellar and foundation plan; roof plan; first and second floor plans; front, rear, two side elevations; wall sections and all necessary interior details. Specifications consist of about twenty pages of typewritten matter.

Full and complete working plans and specifications of this house will be furnished for \$5.00. Cost of this house is from about \$1,000.00 to about \$1,800.00, according to the locality in which it is built.

PRICE
of Blue
Prints, to
gether with
a complete
set of typewritten
specifications is

ONLY
\$5.00

They save
time and
prevent
waste of
material



Design No. 1517

ICE
 se
 s, to-
 r with
 plete
 type-
 en
 ica-
 is
 LY
 .00
 save
 and
 ent
 e of
 rial

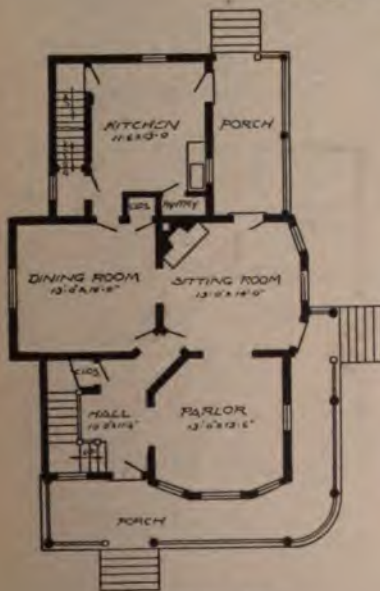

First Floor Plan

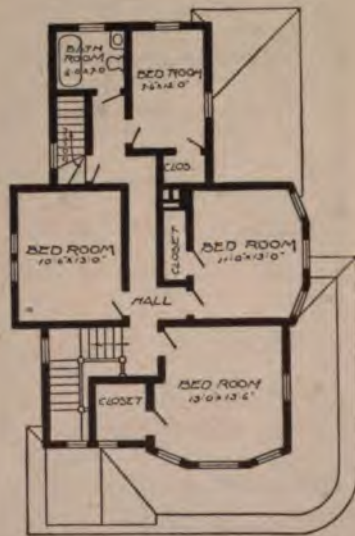

Second Floor Plan

Size: Width, 24 feet 6 inches; length, 44 feet, exclusive of porch

Blue prints consist of cellar and foundation plan; roof plan; first and second floor plans; front, rear, two side elevations; wall sections and all necessary interior details. Specifications consist of about twenty pages of typewritten matter.

Full and complete working plans and specifications of this house will be furnished for \$5.00. Cost of this house is from about \$2,250.00 to about \$2,500.00, according to the locality in which it is built.



Design No. 1514

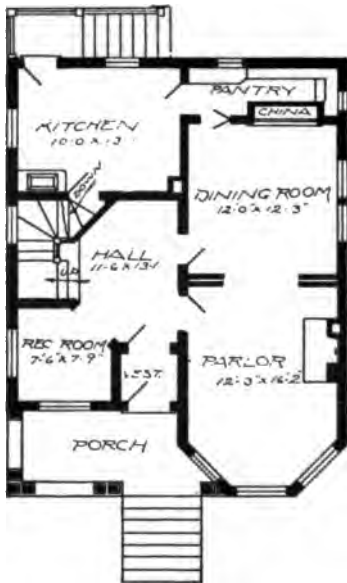

First Floor Plan

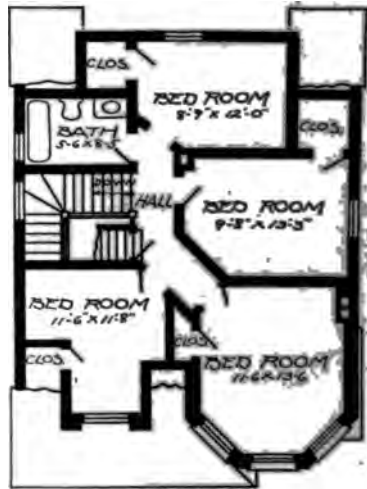

Second Floor Plan

Size: Width, 27 feet; length, 34 feet 6 inches, exclusive of porches

Blue prints consist of cellar and foundation plan; roof plan; first and second floor plans; front, rear, two side elevations; wall sections and all necessary interior details. Specifications consist of about twenty pages of typewritten matter.

Full and complete working plans and specifications of this house will be furnished for \$5.00. Cost of this house is from about \$2,000.00 to about \$2,250.00, according to the locality in which it is built.

P
of
Pri
get
a c
net
wri
spe
tot
C
\$
The
lim
per
the
ma



Design No. 1518

PRICE

of Blue Prints, together with a complete set of typewritten specifications is

ONLY

\$5.00

They save time and prevent waste of material



First Floor Plan

Size: Width, 26 feet 6 inches; length, 41 feet, exclusive of porches

Blue prints consist of cellar and foundation plan; roof plan; first and second floor plans; front, rear, two side elevations; wall sections and all necessary interior details. Specifications consist of about twenty pages of typewritten matter.

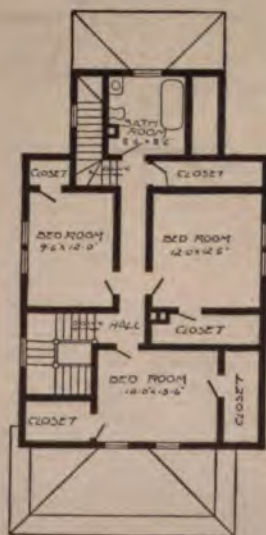

Second Floor Plan

Full and complete working plans and specifications of this house will be furnished for \$5.00. Cost of this house is from about \$1,500.00 to about \$1,750.00, according to the locality in which it is built.



Design No. 1574

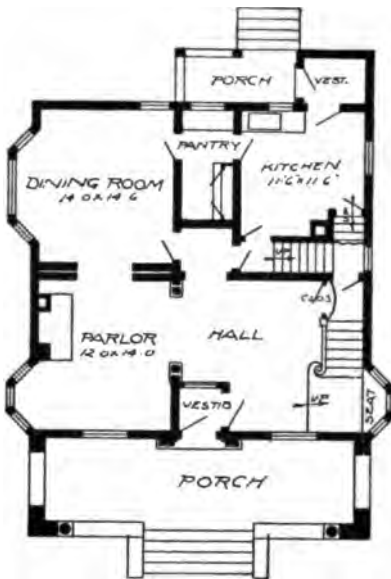

First Floor Plan

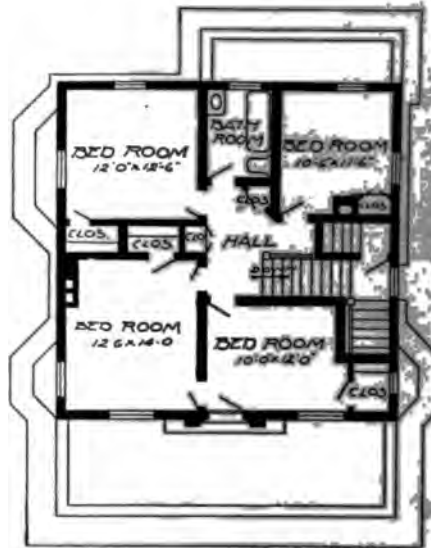

Second Floor Plan

Size: Width, 35 feet; length, 36 feet, exclusive of porches

Blue prints consist of cellar and foundation plan; roof plan; first and second floor plans; front, rear, two side elevations; wall sections and all necessary interior details. Specifications consist of about twenty-five pages of typewritten matter.

Full and complete working plans and specifications of this house will be furnished for \$15.00. Cost of this house is from about \$3,500.00 to about \$3,800.00, according to the locality in which it is built.

Pr
of
Pri
sed
a
ce
rel
spe
tion
O
\$1
The
lim
pre
wa
ma



Design No. 1548

PRICE
of Blue
Prints, to-
gether with
a complete
set of type-
written
specifica-
tions is

ONLY
\$5.00

They save
time and
prevent
waste of
material

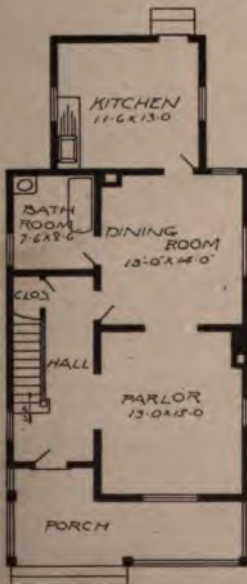

First Floor Plan

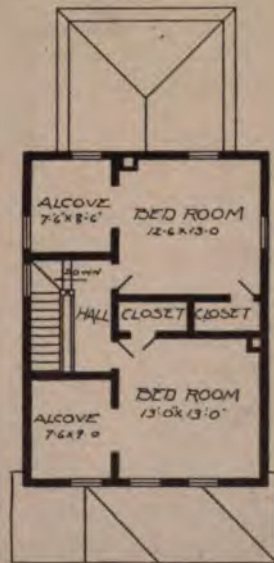

Second Floor Plan

Size: Width, 22 feet; length, 42 feet, exclusive of porch

Blue prints consist of foundation plan; roof plan; first and second floor plans; front, rear, two side elevations; wall sections and all necessary interior details. Specifications consist of about twenty pages of typewritten matter.

Full and complete working plans and specifications of this house will be furnished for \$5.00. Cost of this house is from about \$1,450.00 to about \$1,600.00, according to the locality in which it is built.



Design No. 1558

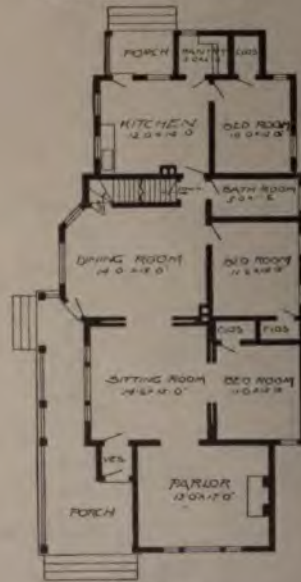

Floor Plan

Size: Width, 31 feet; length, 65 feet 6 inches, exclusive of porches

Blue prints consist of cellar and foundation plan; roof plan; floor plan; front, rear, two side elevations; wall sections and all necessary interior details. Specifications consist of about twenty pages of typewritten matter.

Full and complete working plans and specifications of this house will be furnished for \$5.00. Cost of this house is from about \$1,400.00 to about \$1,700.00, according to the locality in which it is built.

PRICE

of Blue Prints, together with a complete set of typewritten specifications is

ONLY

\$5.00

They save time and prevent waste of material



Design No. 1524

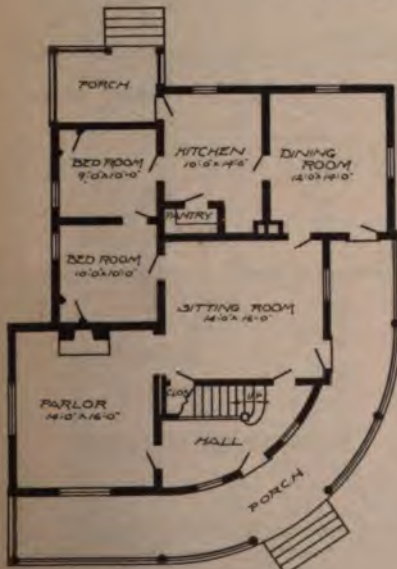

First Floor Plan

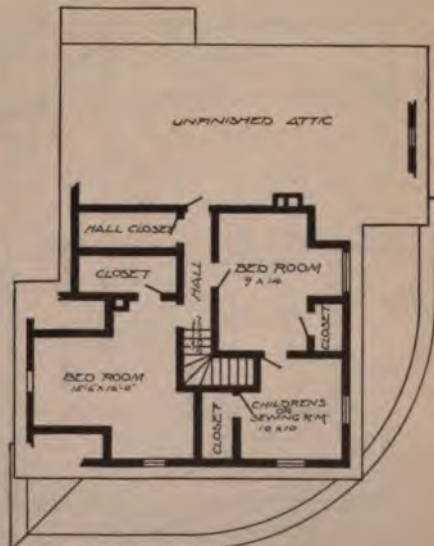

Second Floor Plan

Size: Width, 38 feet 6 inches; length, 40 feet 6 inches, exclusive of porches

Blue prints consist of cellar and foundation plan; roof plan; first and second floor plans; front, rear, two side elevations, wall sections and all necessary interior details. Specifications consist of about twenty pages of typewritten matter.

Full and complete working plans and specifications of this house will be furnished for \$5.00. Cost of this house is from about \$1,950.00 to about \$2,200.00, according to the locality in which it is built.



Design No. 1526

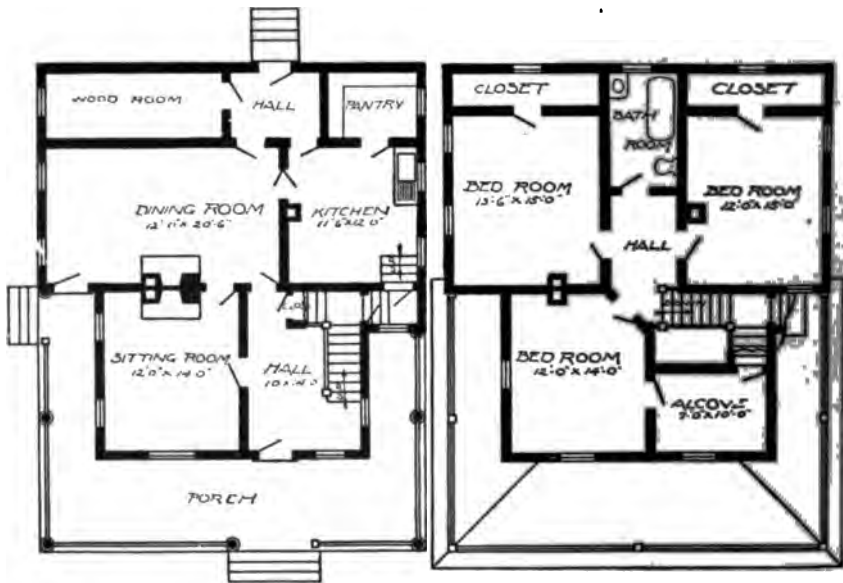

First Floor Plan

Second Floor Plan

Size: Width, 33 feet 6 inches; length, 34 feet, exclusive of porch

Blue prints consist of cellar and foundation plan; first and second floor plans; front, rear, two side elevations; wall sections and details. Specifications consist of about twenty pages of typewritten matter.

Full and complete working plans and specifications of this house will be furnished for \$5.00. Cost of this house is from about \$1,600.00 to about \$1,875.00, according to the locality in which it is built.



Design No. 1542



First Floor Plan

Size: Width, 25 feet 6 inches; length, 41 feet 6 inches, exclusive of porch

Blue prints consist of cellar and foundation plan; roof plan; first and second floor plans; front, rear, two side elevations; wall sections and all necessary interior details. Specifications consist of about twenty pages of type written matter.

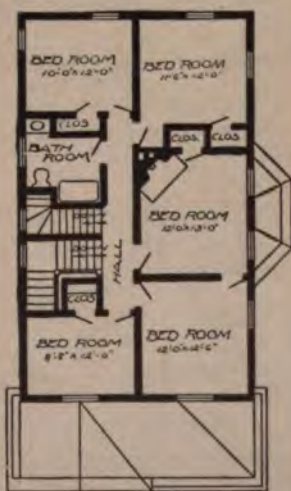

Second Floor Plan

Full and complete working plans and specifications of this house will be furnished for \$5.00. Cost of this house is from about \$1,950.00 to about \$2,150.00, according to the locality in which it is built.



Design No. 1567

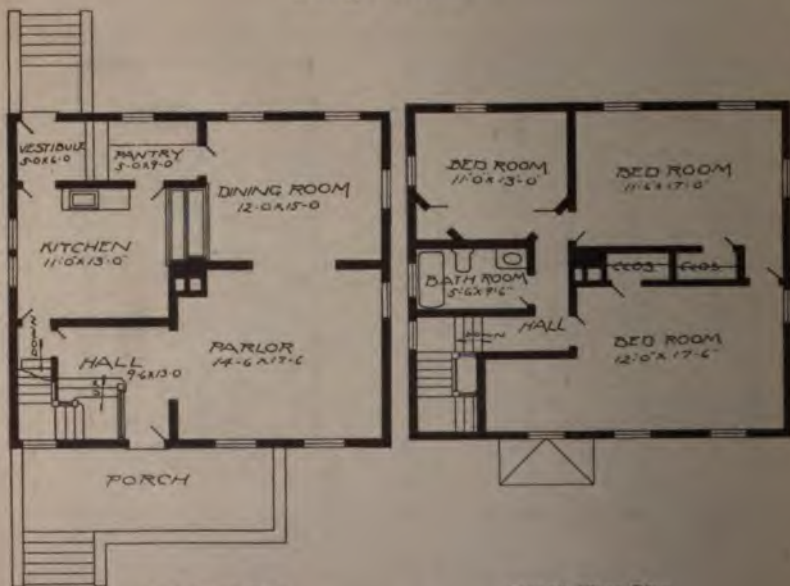

First Floor Plan

Second Floor Plan

Size: Width, 32 feet; length, 28 feet, exclusive of porches

Blue prints consist of cellar and foundation plan; roof plan; first and second floor plans; front, rear, two side elevations; wall sections and all necessary interior details. Specifications consist of about twenty pages of typewritten matter.

Full and complete working plans and specifications of this house will be furnished for \$5.00. Cost of this house is from about \$1,350.00 to about \$1,500.00, according to the locality in which it is built.

PRICE

of Blue Prints, together with a complete set of typewritten specifications is

ONLY \$5.00

They save time and prevent waste of material



Design No. 1515

PRICE

Blue
prints, to-
gether with
complete
of type-
written
specifica-
tions is

ONLY

5.00

By save
and
vent
of
material

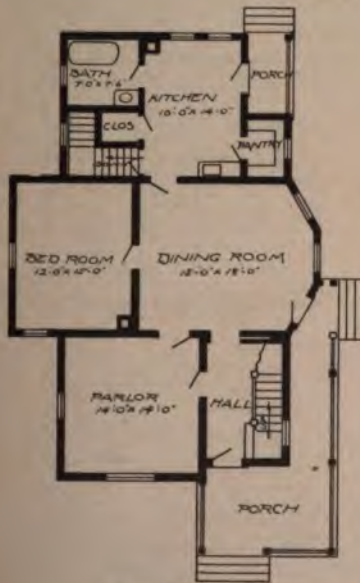

First Floor Plan

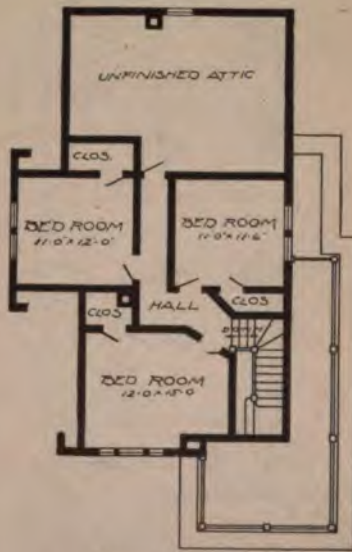

Second Floor Plan

Size: Width, 25 feet 6 inches; length, 41 feet 6 inches, exclusive of porch

Blue prints consist of cellar and foundation plan; roof plan; first and second floor plans; front, rear, two side elevations; wall sections and all necessary interior details. Specifications consist of about twenty pages of typewritten matter.

Full and complete working plans and specifications of this house will be furnished for \$5.00. Cost of this house is from about \$1,600.00 to about \$1,750.00, according to the locality in which it is built.



Design No. 1540

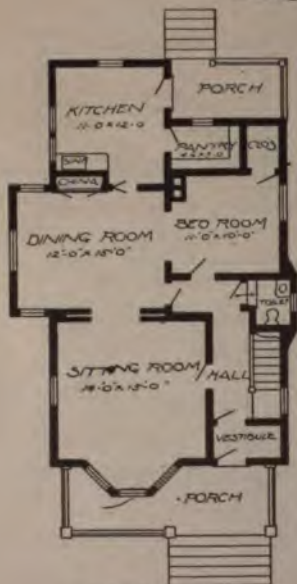

First Floor Plan

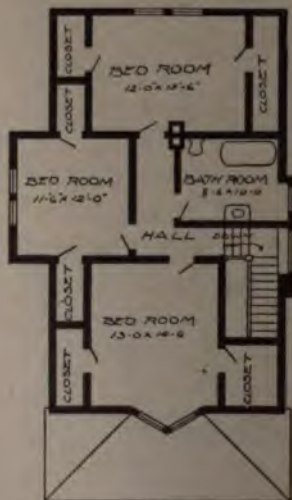

Second Floor Plan

Size: Width, 27 feet 6 inches; length, 40 feet 6 inches, exclusive of porch

Blue prints consist of cellar and foundation plan; roof plan; first and second floor plans; front, rear, two side elevations; wall sections and all necessary interior details. Specifications consist of about twenty-five pages of typewritten matter.

Full and complete working plans and specifications of this house will be furnished for \$5.00. Cost of this house is from about \$1,800.00 to about \$2,000.00, according to the locality in which it is built.

PRICE
of Blue Prints, together with a complete set of typewritten specifications is
ONLY \$5.00

They save time and prevent waste of material



Design No. 1513

PRICE
of Blue
Prints, to-
gether with
a complete
set of type-
written
specifica-
tions is

ONLY
\$5.00

They save
time and
prevent
waste of
material

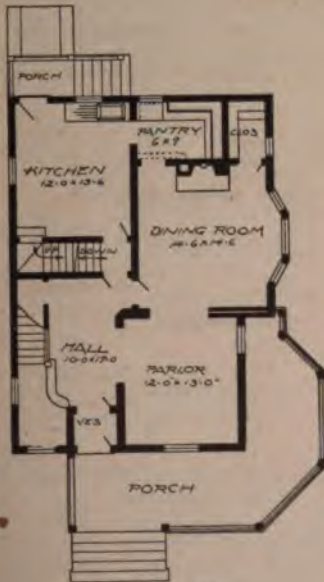

First Floor Plan

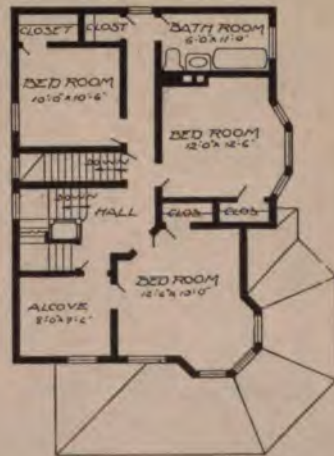

Second Floor Plan

Size: Width, 26 feet 6 inches; length, 35 feet 8 inches, exclusive of porches

Blue prints consist of cellar and foundation plan; roof plan; first and second floor plans; front, rear, two side elevations; wall sections and all necessary interior details. Specifications consist of about twenty pages of typewritten matter.

Full and complete working plans and specifications of this house will be furnished for \$5.00. Cost of this house is from about \$2,200.00 to about \$2,400.00, according to the locality in which it is built.



Design No. 1555

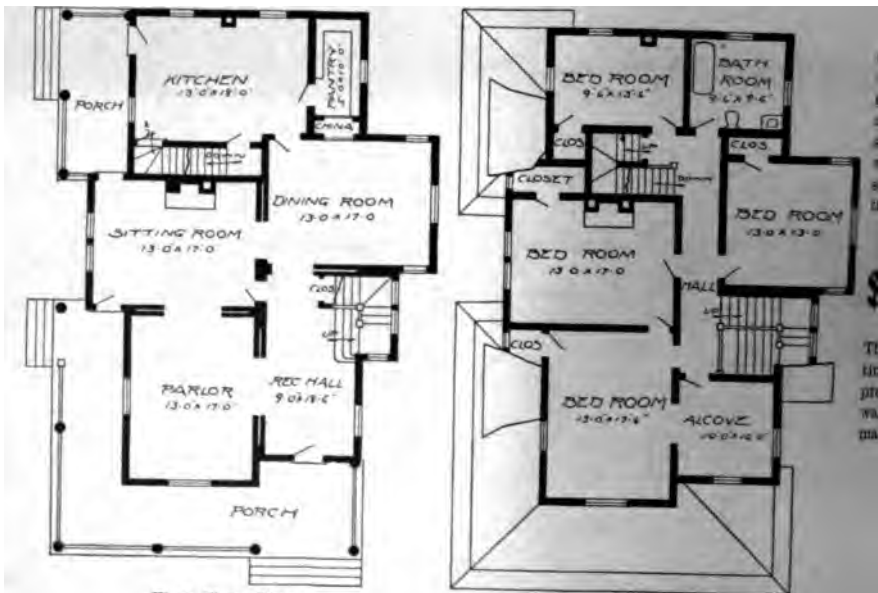

First Floor Plan

Second Floor Plan

Size: Width, 36 feet; length, 49 feet, exclusive of porches

Blue prints consist of cellar and foundation plan; roof plan; first and second floor plans; front, rear, two side elevations; wall sections and all necessary interior details. Specifications consist of about twenty-five pages of typewritten matter.

Full and complete working plans and specifications of this house will be furnished for \$6.00. Cost of this house is from about \$2,750.00 to about \$3,000.00, according to the locality in which it is built.



Design No. 1532

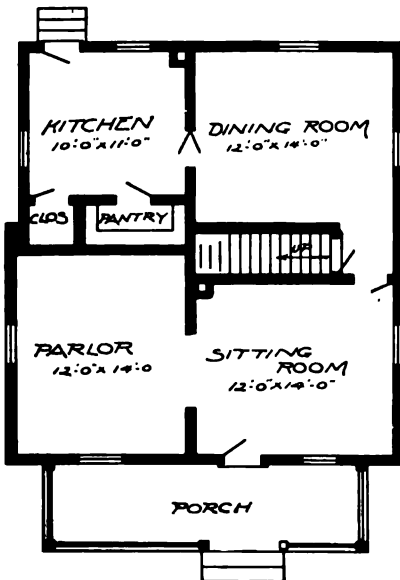

First Floor Plan

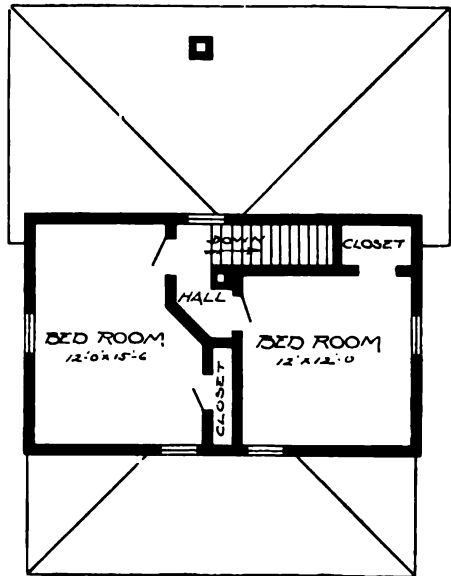

Second Floor Plan

Size: Width, 27 feet 6 inches; length, 29 feet, exclusive of porch

Blue prints consist of foundation plan; first and second floor plans; front, rear, two side elevations; wall sections and all necessary interior details. Specifications consist of about fifteen pages of typewritten matter.

Full and complete working plans and specifications of this house will be furnished for \$5.00. Cost of this house is from about \$25.00 to about \$1,050.00, according to the locality in which it is built.



Design No. 1500

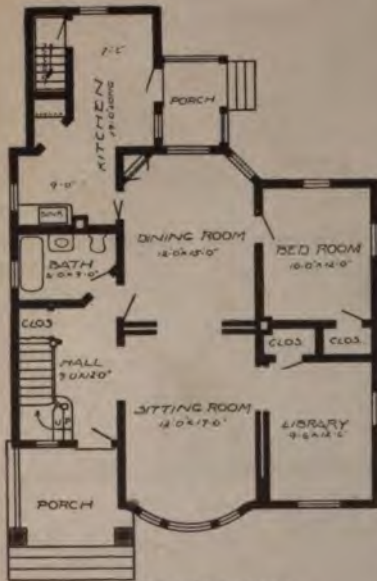

First Floor Plan



Second Floor Plan

Size: Width, 33 feet; length, 44 feet 6 inches, exclusive of porch

Blue prints consist of cellar and foundation plan; roof plan; first and second floor plans; front, rear, two side elevations; wall sections and all necessary interior details. Specifications consist of about twenty pages of typewritten matter.

Full and complete working plans and specifications of this house will be furnished for \$5.00. Cost of this house is from about \$2,150.00 to about \$2,450.00, according to the locality in which it is built.

PRICE
of Blue
Prints, to
gether with
a complete
set of typewritten
specifications is

ONLY
\$5.00

They save
time and
prevent
waste of material

Blue Printed Working Plans and Typewritten Specifications

The House Plans Illustrated in this volume have for their foundation the best equipped architectural establishment ever maintained for the purpose of furnishing the carpenter, contractor and home builder with complete working blue printed plans and typewritten specifications at an average price of only \$5.00 per set. All elevations and floor plans are drawn to a scale of one-quarter inch to the foot. **The regular price charged by others is from \$40.00 to \$75.00 for the same work.** Without this complete and exceptionally well-equipped establishment always at your service, these illustrations of plans would be useless to you. The working plans of any house illustrated by us are held in readiness for you. You do not have to wait a day for them to be prepared.

ONLY \$ 5.00 ONLY

For a Complete Set of Blue Prints and Specifications

Of What They Consist

We use the best quality of Electric Blue Print Paper. We furnish for a set of plans the front elevation, right elevation, left elevation, rear elevation, all floor plans, cellar and foundation plans, and all necessary details. Our specifications consist of from fourteen to twenty pages of typewritten matter, giving full directions for carrying out the work.

Both the plans and specifications are bound in heavy water-proof material, and in an artistic and substantial manner.

Our Guarantee

If upon receipt of our plans you do not find them as accurate, complete and well drawn as any you have ever used or seen, or if you do not consider them good value, we will refund your money.

Industrial Publication Co.

16 Thomas St.

New York

Radford American Homes

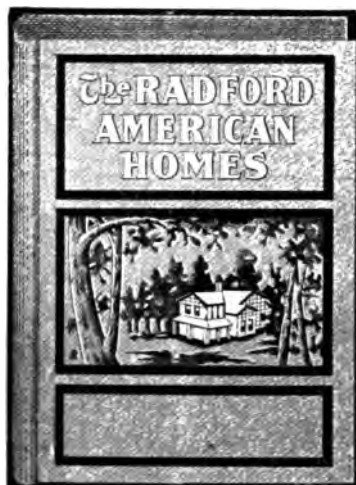

One hundred new house plans
Sells Everywhere for \$1.00

Is our latest and most complete book of house plans. It contains 100 designs of low and medium priced houses, never before illustrated, and has met with phenomenal success. The designs are all original, practical and up-to-date, and have been drawn by licensed architects of the State of Illinois. It is beautifully bound in English cloth, embossed in three colors, gilt top, 256 pages, size 6 1/4 x 8 inches. Price \$1.00, postage paid. We also furnish the complete plans and specifications for any of the designs illustrated in this book at an average cost of only \$5.00 per set, and can send them out immediately upon receipt of your order. These plans are accurate and complete in every detail and will save many times their cost in the construction of a house.

Size 6 1/4 x 8 inches 256 pages 100 new homes
Bound in English cloth Beautifully illustrated Gilt top

Industrial Publication Co.

16 Thomas St., New York

Practical Carpentry

A Complete Up-to-Date Explanation of Modern Carpentry. Two Volumes.



Edited under the personal supervision of William A. Radford, editor-in-chief of "The American Carpenter and Builder," and author of "The Steel Square and its Uses," assisted by Alfred W. Woods, the world's greatest expert on the steel square, and William Reuther, the leading authority on carpentry, joinery and building.

NEW SPECIAL EDITION

This work, "Practical Carpentry," is absolutely new, being completed only January 1, 1907. It was written especially for us, at an enormous expense, and can be obtained from no one else. It is written in simple, plain, every day language so that it can be

easily understood. It will not bewilder the working man with long mathematical formulas or abstract theories.

IT IS THE MOST COMPLETE

most accurate, most up-to-date and most practical work upon this subject. It contains the best and quickest methods for laying roofs, rafters, stairs, floors, hopper bevels, mitering, coping, splayed work, circular work, and, in fact, for forming all kinds of joinery and carpenter work.

SPECIAL CHAPTERS

are devoted to building construction, which takes the carpenter from foundation to roof, with complete illustrations of each detail, such as foundation, windows, cornices, doors, roofs, porch work, etc. There are also special chapters devoted to good and faulty construction and all kinds of framing.

400 SPECIAL ILLUSTRATIONS

There are over 400 illustrations, many of them cover an entire page, and they illustrate completely and instructively the text. They show the detail and actual construction down to the minutest point. They enable the reader to understand the text easily and to follow the work in hand without difficulty.

REMEMBER, this work is the latest one published on this extensive subject (issued January 1, 1907). This edition cannot be obtained from anyone else but ourselves. It was made for us at our order. Each volume measures 6x9 inches, and is bound in cloth with cover design attractively stamped. Contains more than 300 pages in each volume. Printed on an excellent quality of paper. Each volume contains 50 modern house plans.

Price \$1.00 per volume, postpaid.

INDUSTRIAL PUBLICATION CO.

16 THOMAS ST., NEW YORK

The RADFORD IDEAL HOMES

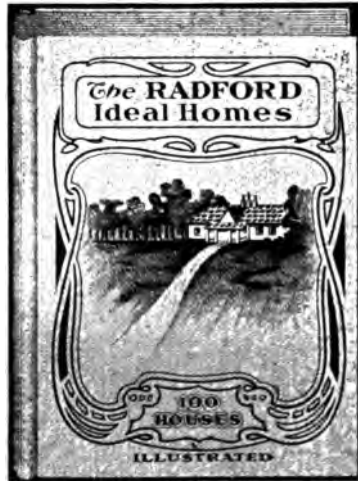

100 Houses for \$1.00 ONE CENT PER HOUSE

Size of book 8 x 11 inches, bound in English cloth, cover embossed and printed in two colors. All houses illustrated with halftone cuts on the very finest enamel paper. The illustrations show the houses exactly as they will appear when built, and no liberties have been taken to make them appear otherwise. All the floor plans are shown, giving the size and location of all rooms, closets, porches, etc., so that ideas are given as to both the interior and exterior of these 100 homes. The houses illustrated are medium in price, and such as 80 to 90 per cent of the people of the United States wish to build today.

ADDRESS

Industrial Publication Co.
16 Thomas St., New York

