

# IMPROVE POWER PLANT CONTROL QUALITY TO STABILIZE THE GRID SYSTEM

## NÂNG CAO CHẤT LƯỢNG ĐIỀU KHIỂN NHÀ MÁY ĐIỆN ĐỂ ỔN ĐỊNH HỆ THỐNG LƯỚI ĐIỆN

Nguyen Thi Nga<sup>1,2,\*</sup>

### ABSTRACT

This paper presents the power plant systems in Vietnam, when making connections between the plants and the national grid system, the paper introduces the current conventional power source and control method. and since then build intelligent control method and apply it in practice today.

Intelligent control has shown ways to design controllers and apply soft computing tools as well as newly applied algorithms. With increasingly high technical requirements, the grid's backup is getting smaller and smaller and the grid system is expected to be flexible and intelligent to meet the increasing requirements of automation, especially the power industry is prioritizing. digital transformation in the power plant system with the Internet of Things (IoT) and using artificial intelligence (AI) to apply it to production practices and improve operational efficiency and labor productivity, creating high economic value for the electricity industry and the country. Currently, intelligent control is being interested by scientists and businesses, wishing to apply technology and be at the forefront of technology and modernize the production process of enterprises.

In this paper, the grid stability control problem is presented through the design of the ANN-MPC controller to control hydro turbines, in which the simulation results are compared with the obtained results. from the ANN-MPC controller and compare with the PID controller.

**Keywords:** PID control, MPC predictive control, artificial neural network, load frequency, hydroelectric control.

### TÓM TẮT

Bài báo này trình bày về các hệ thống nhà máy điện ở Việt Nam, khi thực hiện các kết nối giữa các nhà máy với hệ thống lưới điện Quốc gia, bài báo đã giới thiệu về các nguồn điện và phương pháp điều khiển thông thường từ đó xây dựng phương pháp điều khiển thông minh và áp dụng vào thực tế hiện nay.

Điều khiển thông minh đã chỉ ra được các cách thiết kế các bộ điều khiển và ứng dụng các công cụ tính toán mềm cũng như các thuật toán mới được áp dụng. Với các yêu cầu kỹ thuật ngày càng cao, công suất dự phòng của lưới điện ngày càng nhỏ và mong muốn hệ thống lưới điện phải linh hoạt và thông minh đáp ứng được yêu cầu tự động hóa ngày càng cao, đặc biệt ngành điện đang ưu tiên chuyển đổi số trong hệ thống nhà máy điện với lưới điện được kết nối vạn vật (IoT) và sử dụng trí tuệ nhân tạo (AI) để áp dụng cho thực tiễn sản xuất và nâng cao hiệu quả hoạt động và năng suất lao động, tạo ra giá trị kinh tế cao cho ngành điện và đất nước. Hiện nay điều khiển thông minh đang được các nhà khoa học và doanh nghiệp quan tâm, mong muốn áp dụng công nghệ và đi đầu công nghệ, hiện đại hóa quá trình sản xuất của doanh nghiệp.

Trong bài báo này, bài toán điều khiển ổn định lưới điện được trình bày thông qua việc thiết kế bộ điều khiển ANN-MPC để điều khiển tua bin thủy điện, trong đó các kết quả mô phỏng được so sánh với kết quả thu được từ bộ điều khiển ANN-MPC và so sánh với bộ điều khiển PID.

**Từ khóa:** Điều khiển PID, điều khiển dự báo MPC, mạng nơron nhân tạo, tần số tải, điều khiển thủy điện.

<sup>1</sup>Electric Power University

<sup>2</sup>Quangninh Thermal Power Plant

\*Email: ngant@epu.edu.vn

Received: 20/8/2021

Revised: 22/9/2021

Accepted: 25/10/2021

### 1. INTRODUCTION

Vietnam's electricity system has a number of power plants such as; hydroelectricity, thermal power, solar power, wind power, nuclear power, etc. To supply electricity to households consuming loads. The generation and supply of electricity to the grid continuously fluctuates, leading to fluctuations in the capacity and frequency on the grid. Stabilizing the power and frequency on the grid is a very important and necessary issue needed to improve power quality. Many scientists and researchers on control systems of power plants have also been published.

The intelligent controller presented in [1] shows how to design optimal controllers and algorithms. In [3] gives the power generation standards for hydroelectric and thermal power plants. In [4 - 6], the design of a small hydro turbine controller is given. In [7 - 9], regional linkage hydroelectricity was designed and basically solved the quality of regional link control. In [10] set the parameters of the PID controller for hydroelectric turbines. In [12 - 14], a mathematical model of a region-linked hydroelectric turbine is given. In [15 - 16], neural networks and fuzzy logic are used to design a hydro turbine controller.

Intelligent control has introduced methods to design and apply fuzzy controllers and artificial neural networks, genetic optimization algorithms GA, PSO [1].

Improving the quality of the power system is a very important and

necessary job, if the system is unstable, it will lead to power loss, poor power quality and instability when the grid power and frequency change. change, if the power control system does not participate in fast and optimal control, it will lead to instability and potential grid failure. grid failure is very dangerous for the national grid out. Therefore, research to improve the quality of the power grid system is always encouraged and expected.

In this report, the authors present the design of the MPC-ANN controller to control the speed of hydroelectric turbines, thereby comparing the PID controller with the MPC-ANN controller to choose the best controller. can be applied to the reality of the power plant.

**2. POWER FACTORY MODEL**

**2.1. Hydropower plants**

Introduction to hydropower plants: Hydroelectricity is a source of electricity generated by converting energy from water in the form of potential energy into mechanical energy to rotate turbines - generators to generate electricity to supply loads. However, during the operation of the load, there are always fluctuations such as: power grid failure, change in capacity, frequency and working mode of the unit and load leading to instability of the power system.

The task of the hydroelectric power plant is to use the energy of the water flow to rotate the turbine, rigidly connect the turbine shaft to the generator and make the generator crank and generate electricity (Figure 1).



Figure 1. Hydroelectric power plant

**2.2. Thermal power plants**

Introduction to thermal power plants: General working principle of thermal power plants using backpressure turbines: Water is pumped from the reservoir to the boiler. The steam coming out of the boiler is saturated steam, and it is further heated by the heater into superheated steam and fed to the turbine which turns the generator. In addition to running the generator, the plant uses a counterpressure turbine to run the heat load. The steam after being used to run the heat load is also condensed by the condenser and pumped back to the storage tank. Then from the tank that has not been filled with water, it is pumped to the boiler, continuing the process of generating steam, feeding it to the turbine and running the generator.



Figure 2. Thermal power plant model

**2.3. Solar power plant**

Introduction to solar power plants: Solar power is electricity converted from sunlight through solar panels. Based on the photoelectric effect of the semiconductors inside the solar panels, thereby converting the sun's light energy into electricity to provide for human activities and production, which is shown in (Figure 3).



Figure 3. Solar power plant

**2.4. Wind power plant**

Introduction to wind power plants: When the wind hits the propeller, the propeller starts to rotate. The turbine rotor is connected to a high-speed gearbox. The gearbox transforms the rotation of the rotor from low speed to high speed. The high speed shaft from the gearbox is coupled to the rotor of the generator and thus the generator



Figure 4. Wind power plant

Comment: With distributed energy sources capable of participating in the generation of electricity into the National Grid, it will add a significant amount of capacity, increasing the storage capacity and increasing the reliability and safety of the grid. electricity to reduce the selling price of electricity. However, when there are many distributed energy sources participating in the national grid system, it will lead to great fluctuations and instability in the power grid. Because the power supply sources are unstable, depending on time, coal mining raw materials, imports, seasonal weather, etc. Therefore, stabilizing power and grid frequency is always an urgent requirement Researchers as well as professionals are very interested and have used methods to keep power and frequency stable to increase power output, a method to participate in the quality improvement process.

That power is a method of stably controlling the generating capacity of plants when the load changes. However, this method has also been of interest to researchers and businesses and the power industry.

However, with increasing requirements, the limit of capacity reserve on the grid is getting smaller and smaller, so the power industry always requires to improve reliability, safety and flexible and intelligent control for the process electricity generation.

Power plants when adjusting the generating capacity through adjusting the generator turbine and changing the generating capacity. Currently, the control system of hydroelectric and thermal power plants is using traditional PID controller, this method has also solved the basic problem in production. However, with increasing requirements, requiring a reliable, safe, flexible and intelligent power grid to meet the increasing requirements of automation, intelligent control methods are applied to the control process. Turbine speed regulation is very important and necessary.

**3. DESIGN OF FORMAT CONTROLLER MPC**

The software tool MATLAB/simulink is the simulation result of the MPC-ANN controller which is better than the PID controller, when replacing the PID controller with the MPC-ANN controller

The application of MPC in power system has achieved good results recently. Usually MPC when integrated with ANN.

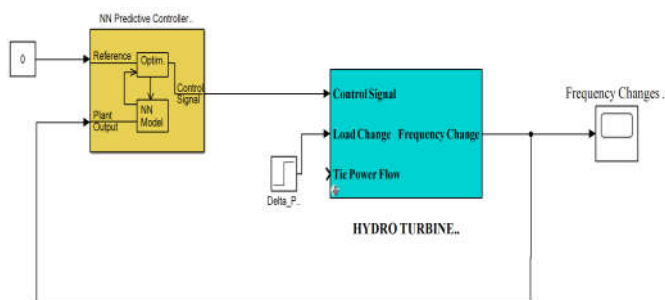

Figure 5. MPC-ANN control for hydroelectric generator turbine

Model ANN-MPC controller to control turbine turbine generator (Figure 5).

- Simulation on matlab simulink software (figure 6).

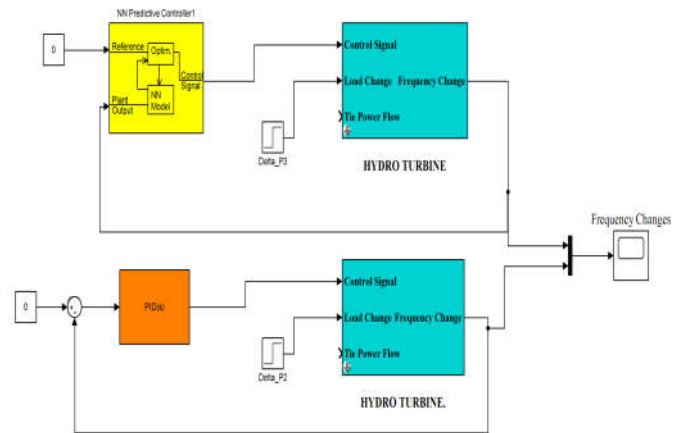

Figure 6. System simulation diagram objective function

$$j = \int_0^T (|\Delta f(t)| + |\Delta P(t)|) dt \rightarrow \min$$

Train the ANN-MPC controller. This is the final step to complete the ANN-based controller (Figure 7).

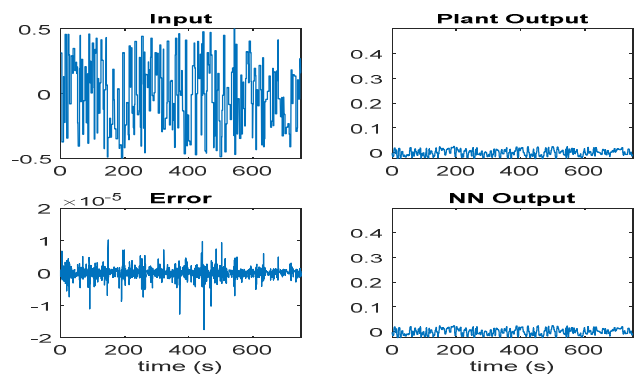

Figure 7. Neural network training data

**4. SIMULATION RESULTS**

When we change the load according to the load graph (Figure 8), the output response is obtained (Figure 9). We can observe between two controllers PID and MPC-ANN. On the chart, it can be seen that the control quality of MPC-ANN controller has much better quality such as small over-adjustment, small static error, faster steady-state mode than traditional PID controller.

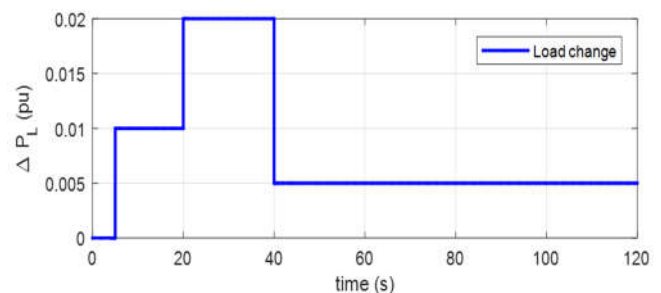

Figure 8. When the load changes

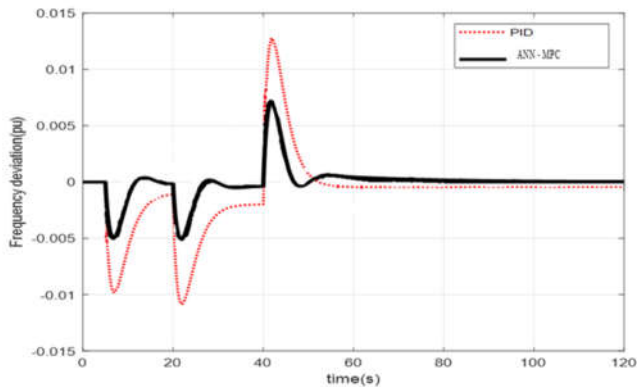

Figure 9. Output response

## 5. CONCLUSION

This report presents the problem of controlling hydroelectric turbines with a better quality ANN-MPC controller to replace the traditional PID controller. When the load change leads to a change in the grid frequency, in order to reduce the frequency deviation, the grid speed (frequency) feedback signal has been sent to the speed regulator to stabilize the turbine speed and frequency, grid number.

The next development direction of the report is to optimize multitasking and create a new intelligent controller to apply to the reality of factories.

## REFERENCES

- [1]. Huynh Thai Hoang, 2016. *He thong dieu khien thong minh*. Vietnam National University Ho Chi Minh City Press.
- [2]. Vu Duy Thuan, 2017. *Study on stabilization and optimization of a large-scale system applying for power systems*. Engineering doctoral thesis, Vietnam Academy of Science and Technology.
- [3]. Circular No. 25/2018/TT-BCT dated September 12, 2018 of the Minister of Industry and Trade amending and supplementing the Circular No. 16/2014/TT-BCT dated May 29, 2014 on electricity prices
- [4]. Hoang Nhat Duc, Le Cong Hai, 2019. *Applications of Differential Evolution for Solving Structure Design Optimization 5 Problems with DE-Excel Solver*. DTU Journal of Science & Technology 03(34) (2019), 97-102.
- [5]. Nguyen Hong Quang, 2013. *Nghien cuu thiet ke che tao thiet bi dieu khien nhung ung dung cho cac tram thuy dien*. Science research topic code 43/2009G/HĐ-ĐTĐL.
- [6]. Nguyen Dac Nam, 2017. *Research and application of neural fuzzy network to build control algorithm for turbine speed control system - hydroelectric generator*. Engineering doctoral thesis, Hanoi University of Science and Technology.
- [7]. D. T. Nguyen, N. K. Nguyen, H. L. Le, V. T. Nguyen, 2019. *Designing PSO-Based PI-type Fuzzy Logic Controllers: A Typical Application to Load-Frequency Control Strategy of an Interconnected Hydropower System*. ICACR 2019: Proceedings of the 2019 3rd International Conference on Automation, Control and Robots, 61-66. <https://doi.org/10.1145/3365265.3365278>.

[8]. D. T. Nguyen, N. K. Nguyen, H. L. Le, V. T. Nguyen, 2020. *Intelligent ANN - Based load frequency control strategies for an interconnected hydropower system*. Journal of military science and technology research No. 65, 43-54.

[9]. D. T. Nguyen, N. K. Nguyen, H. L. Le, V. T. Nguyen, 2020. *Study on application of ANN - based MPC controller for load - frequency control of an interconnected hydropower Plant*. Journal of military science and technology research, No. 65, 86 -97.

[10]. Nguyen Trung Thi, Doan Quang Vinh, 2010. *Fuzzy adjusting pid parameters of the hydroelectric power turbine governor*. Journal of Science and Technology - The University of Danang No 4(39), 324-331

[11]. Dang Tien Trung, 2019. *Research and application of modern measurement and control solutions to improve the quality of frequency stability in small and medium hydropower plants*. Engineering doctoral thesis, Military Technical Academy.

[12]. Aditya S., Das D., 2003. *Design of load frequency controllers using genetic algorithm for two area interconnected hydro power system*. Electric Power Components and Systems 31(1): 81-94.

[13]. Kundur P., 1994. *Power system stability and control*. New York, USA: McGraw-Hill.

[14]. R. C. Dorf, R. H. Bishop, 2008. *Modern Control Systems*. Pearson Prentice Hall.

[15]. R. Verma, S. Pal, S. Sathans, 2013. *Intelligent Automatic Generation Control of Two-Area Hydrothermal Power System Using ANN and Fuzzy Logic*. In: 2013 International Conference on Communication Systems and Network Technologies (CSNT), pp. 552-556.

[16]. Norgaard M., Poulsen N. K., Hansen L. K., Ravn O., 2003. *Neural Networks for Modelling and Control of Dynamic Systems*. Springer.

## THÔNG TIN TÁC GIẢ

Nguyễn Thị Nga<sup>1,2</sup>

<sup>1</sup>Trường Đại học Điện Lực

<sup>2</sup>Nhà máy Nhiệt điện Quảng Ninh