

# Protocol Converter Quick Start Guide



Protocol Converter - Single EIA-485 port



Dual Port  
Protocol Converter - Three EIA-485 ports

Thank you for purchasing a Protocol Converter. Before you begin to install and configure your device, consult rletech.com to ensure you're working with the most recent version of documentation for that product. The Protocol Converter User Guide is also available at rletech.com. If you need additional assistance, email our support staff - support@rletech.com, or call us at 800.518.1519.

# Raptor

v05.21



© Raymond & Lae Engineering, Inc. 2011. All rights reserved. RLE® is a registered trademark and Seahawk™, Falcon™, and Raptor™ are trademarks of Raymond & Lae Engineering, Inc. The products sold by Raymond & Lae Engineering, Inc. are subject to the limited warranty, limited liability, and other terms and conditions of sale set forth at <http://rletech.com/RLE-Terms-and-Conditions.html>.

## Installation Supplies

### Included with the Protocol Converter

Protocol Converter device  
PSWA-DC-24: 24VAC power supply  
Rack-mount brackets

### Available from RLE, sold separately

18 – 22 AWG ground wire

### Optional supplies

18AWG shielded twisted pair stranded copper wire - no more than 2000ft (610m)  
(Modbus RTU communication via EIA-485 port)  
CAT 6 crossover network cable  
CAT 5 straight-through cable  
Straight-through, nine-pin serial cable

## Network Communications Information

Consult your IT administrator and determine the following Protocol Converter network settings:

- IP Address \_\_\_\_\_
- Subnet Mask \_\_\_\_\_
- Default Gateway \_\_\_\_\_

## Mount the Device

RLE recommends installing the Protocol Converter in a 19-inch rack and provides mounting brackets with each unit. Remove the screws from the side of the device, put the brackets in place, and reapply the screws. Use the proper anchoring method to mount the unit securely.

## Provide a Power Supply and Ground Connections

Power the Protocol Converter from a UPS supply so the device can send alarm notifications during a power outage. Power can be supplied to the Protocol Converter through either the power jack and the provided wall adapter or the power supply terminal block.

1. Connect an 18AWG ground wire from the ground terminal (marked on the upper left side of the enclosure) to a suitable earth ground.
2. Plug the provided wall adapter into the jack at P1 and the UPS outlet. The wall adapter has a five foot (1.524m) power cord.
3. If you're providing your own power supply, connect 24VDC to the unit through the power terminal block.

## Connect the Protocol Converter to the Network

The Protocol Converter needs network connectivity in order to access the web interface and configuration screen, and to activate the email (SMTP), BACnet, Modbus, and SNMP features. Use a CAT 6 crossover cable to connect the 10/100BASE-T Ethernet port directly to a PC. Use a straight-through CAT 5 cable to connect the Protocol Converter to a network hub or switch.

## EIA-232 Connection

The Protocol Converter can be connected directly to a PC through its EIA-232 port. Designed for temporary use, this connection supports IP configuration, firmware downloads, and troubleshooting. Connect via a straight through, 9-pin serial cable.

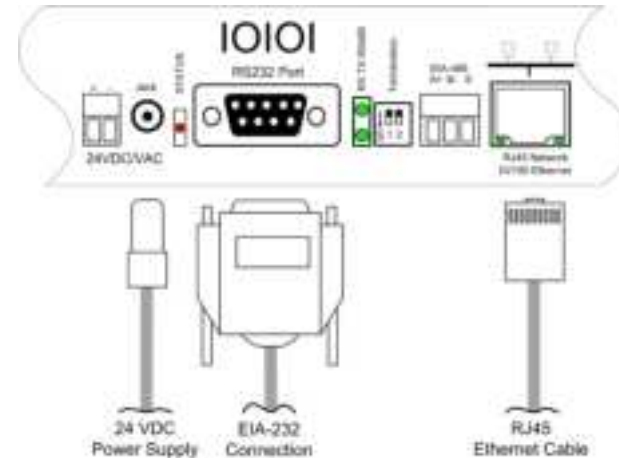

## Modbus EIA-485 Connections

The Protocol Converter can function as a Modbus Client or Modbus Server over an EIA-485 hardware connection. The base Protocol Converter has one 2-wire EIA-485 connection. The dual port Protocol Converter has two 2-wire EIA-485 connections and one 2- or 4-wire EIA-485 connections for extended Modbus polling over multiple trunk lines.

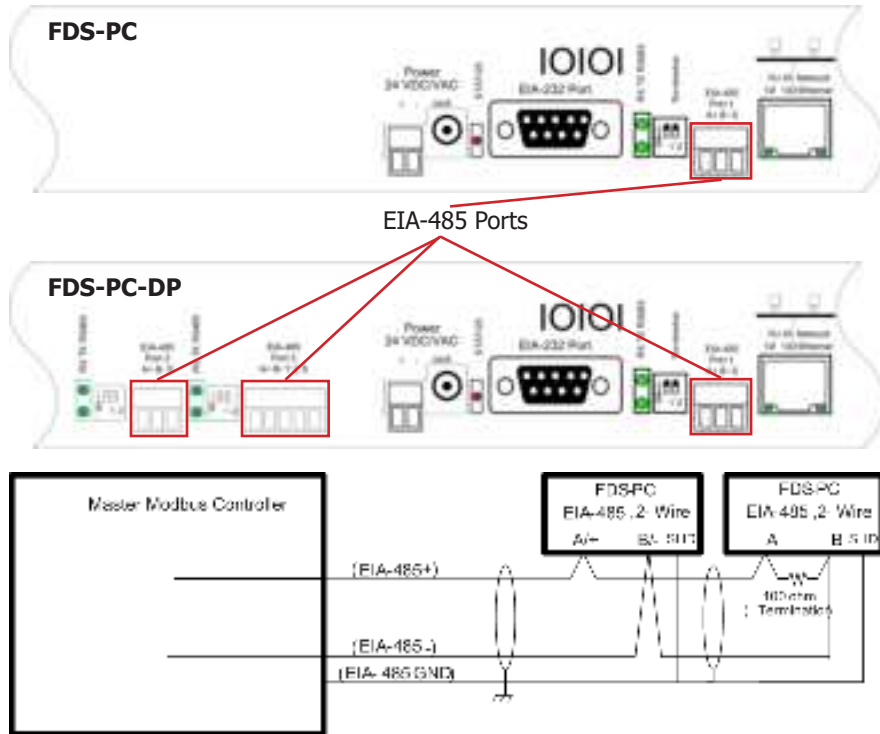

## Set the IP Address Using a Web Browser

The Protocol Converter will not communicate over your network the first time it is connected. Since it is shipped with a default IP address of 10.0.0.188, you'll need to change the default IP address to one that will allow it to communicate over your network. If you have not set an IP address before, consult your IT Department for support.

Note: The default IP address for the Protocol Converter is 10.0.0.188  
The default Subnet Mask is 255.255.255.0  
The default user name is fds (all lowercase)  
There is no default password - leave the password field empty.

1. Contact your IT Department to obtain an available IP address, Subnet Mask, and default Gateway.
2. Plug a crossover network cable into the laptop or workstation that will be used to configure the Protocol Converter.
3. You'll need to change the IP address and Subnet Mask of your computer so it

can communicate with the Protocol Converter in its factory-configured state. Before you change anything, write down the original IP address and Subnet Mask of your computer - you'll need to revert back to these original settings once the Protocol Converter is configured.

4. Change the IP address and Subnet Mask of the computer from its existing address to one that will allow it to communicate with the Protocol Converter, such as 10.0.0.189. It may be beneficial to set the IP address to one that is one number different from the Protocol Converter's IP address (10.0.0.188).
5. Connect the other end of the crossover cable to the Ethernet port on the back of the Protocol Converter.
6. Access the Protocol Converter through a web browser — type the Protocol Converter's IP address (10.0.0.188) into the location bar. When prompted, enter the Protocol Converter's user name, which is fds. There is no default password, leave it blank.
7. Select the Configuration link from the top menu bar, then select the Network and web option that appears in the Configuration Menu on the left side of the screen. Change the Protocol Converter's IP address, Subnet Mask, and default Gateway to the one provided by your IT Department. Press the Submit Changes button. The Protocol Converter will save the new IP address, Subnet Mask and default Gateway and reboot.
8. Change the IP address of the computer back to its original IP address. If the computer was configured as DHCP (the network domain controller assigns an IP address) return it to this state. This may require assistance from your IT Department, or you may need to consult the computer's manual.
9. The computer and the Protocol Converter are now both configured to communicate on the network. Both should be accessible via the network. Connect the PC and the Protocol Converter to the network. From the PC web browser, type in the new IP address of the Protocol Converter. Enter the user name and password as stated above to verify network access to the device.

## Complete the Configuration

Once the Protocol Converter has been hardwired and the IP address has been set, it's ready to be fully configured. It will be able to communicate over a network and through it's communication ports, but you will still need to perform additional tasks to configure the devices connected to the Protocol Converter.

Access the web interface and the complete Protocol Converter user guide - available at [www.rletech.com](http://www.rletech.com) - to complete the configuration.