

ALPINE TRAIL



TECHNICAL MANUAL

TABLE OF CONTENTS

Important Information	2	Bear Box Downtube Storage & Bag	6
Changing the Rear Wheel Size	3	Cable Routing & Rubber Grommets	7
Adjusting the Bottom Bracket & Chainstay Length	4	Frame Technical Specifications	9
Adjusting the Headtube Angle	5	Marin Customer Support	11

IMPORTANT INFORMATION

The Marin Alpine Trail is a bike that can be adjusted to match the rider's needs and terrain. This document is intended to supplement the complete owner's manual. This document contains an overview of some parts diagrams, specifications, and adjustment instructions. This document is NOT a complete owner's manual and does not include important safety and installation information. You must refer to the complete owner's manual and get help from your official Marin dealer with assembly, use, service, and maintenance. Visit marinbikes.com/support for more information.

Failure to follow proper assembly instructions, hazard warnings, and compatible part recommendations may result in loss of control while riding and can lead to serious injury and/or death. We recommend having your bike assembled, adjusted, and serviced by a trained, professional bicycle mechanic. This manual is not intended to replace the assembly and service instructions provided by third-party component manufacturers.

CHANGING THE REAR WHEEL SIZE

The Alpine Trail bike comes from the factory with a mixed wheel size set up (29" front/27.5" rear), and can also be setup as a full 29" wheel size bike. The rear wheel size can be changed to a 29" rear wheel (sold separately) by rotating the flip chips at the seatstay and rocker link pivot. To change to a 29" rear wheel, follow the steps below.

Note: The 29" rear wheel is NOT included and must be purchased separately. The Alpine Trail is designed around a 29" front wheel, and this wheel size should not be changed.

WARNING: Do not use a 27.5" rear wheel when the bike is in the 29" flip chip setting. This will result in a bottom bracket that is too low and unsafe, which can cause a crash, serious injury, and/or death.

1. Use a 6 mm hex wrench to remove the bolts on the left and right side of the rocker link.
2. Rotate the flip chips 180 degrees, so the "29" laser etching will be right side up.
3. Use a 6 mm hex wrench to reinstall the pivot bolt, torque bolts to 20 N•m. The frame is now ready to accept a 29" rear wheel.

1

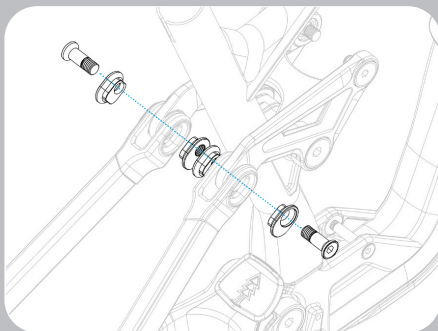

2

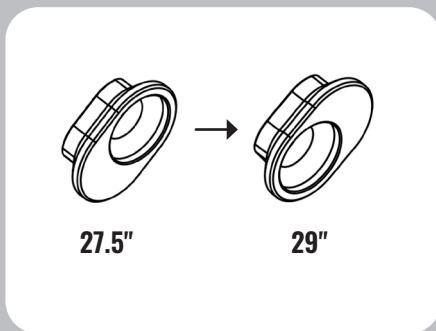

3

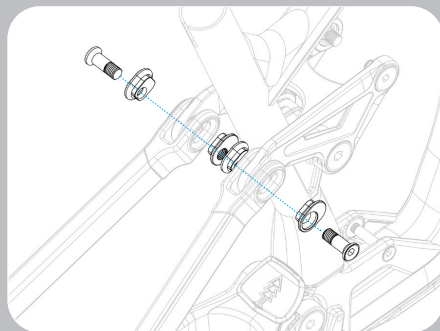

ADJUSTING THE BOTTOM BRACKET & CHAINSTAY LENGTH

The Alpine Trail frame can be adjusted at the bottom bracket (BB) and chainstay (CS) to adapt to the trail and rider's preferences. No matter the rear wheel size, 27.5" or 29", the rider can choose between the factory setting LOW BB and LONG CS or a HIGH BB and SHORT CS position. To change to the HIGH BB and SHORT CS position, follow the steps below.

1. Remove the rear wheel. Then use a 6 mm hex wrench to remove the pivot bolts on the left and right chainstay rear pivot.
2. Rotate the flip chips 180 degrees (from LOW to HIGH). The HIGH call out will be right side up.
3. Use a 6 mm hex wrench to reinstall the two pivot bolts. Torque the bolts to 20 N·m. Reinstall the rear wheel. The bike is now in the HIGH BB and SHORT CS position.

1

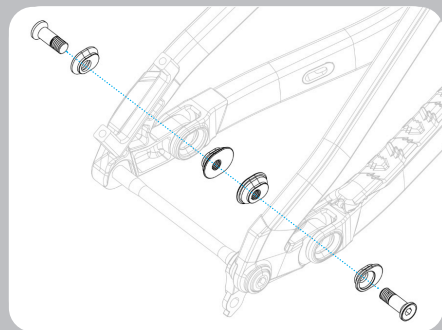

2

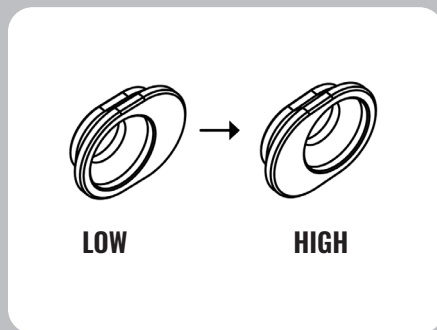

3

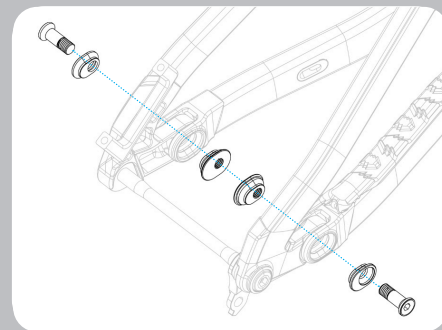

ADJUSTING THE HEADTUBE ANGLE

The Alpine Trail bike features an adjustable headtube angle which can be changed by swapping the upper headset cup. The factory setting is the ZERO offset cup and is set to 63.5 degrees. A steeper headtube angle (-0.75) gives increased agility for climbing, and a slacker headtube angle (+0.75) offers increased stability for descending. To change the headtube angle by +/- 0.75 (64.25 or 62.75) degrees, follow the steps below.

1. Use a 4 mm hex wrench to remove the stem bolts. Use a 5 mm hex wrench to remove the top cap bolt. Remove the stem, spacers, top cap, and upper bearing. Remove the ZERO upper headset cup.
2. Note the laser etched -0.75 and +0.75. The marking that is pointing to the front of the bike indicates the headtube angle adjustment.
3. Select and install your preferred upper headset cup.
4. Reinstall the other headset parts in the correct order and tighten the headset compression bolt (3-4 N•m) and then align the stem and tighten the stem bolts to 5-6 N•m (see stem for exact torque recommendations). Make sure the assembly is aligned and all parts are in place. Check the headset for play. If play exists, do not ride the bicycle and contact your local Marin dealer.

1

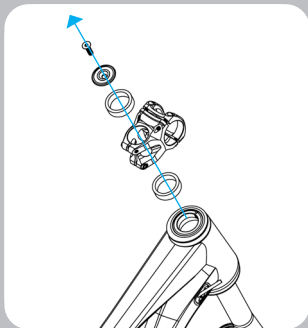

2

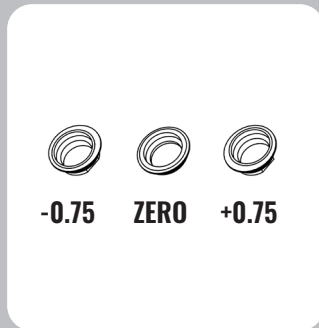

3

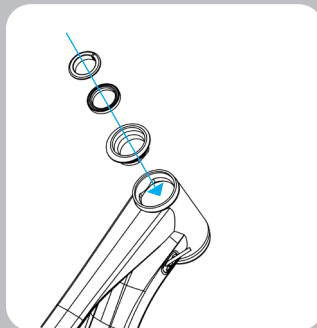

4

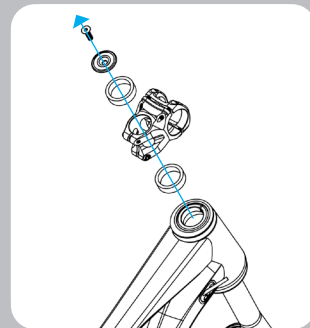

BEAR BOX DOWNTUBE STORAGE & BAG

This bike features the Marin Bear Box downtube storage. The included bag is designed to hold a TPU tube, minipump and tools. Note that a standard innertube is too large and will not fit; a TPU tube is the only tube that will fit in the bag. A standard tube can be mounted under the top tube.

1. To open the door of the Bear Box, lift the latch on the drive side. Then, carefully pull the door towards the drive side of the bike so the locating tabs are fully removed from the frame.

NOTICE: Be careful to fully remove the locating tabs from the grooves in the frame as you remove it toward the drive side of the bike. Failure to do so can break the locating tabs and cause damage to your Bear Box.

2. Pull the bag out of the Bear Box and place supplies inside. Make sure supplies are secure, then push the bag back into the Bear Box.
3. To close the Bear Box, carefully insert the locating tabs of the door into the non-drive side grooves in the frame, then close and latch the door.

1

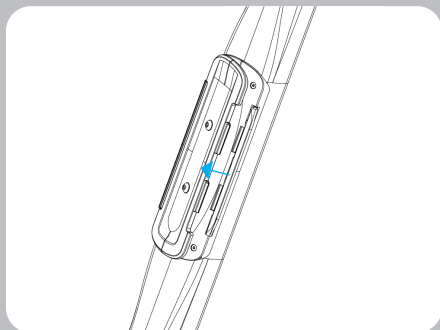

2

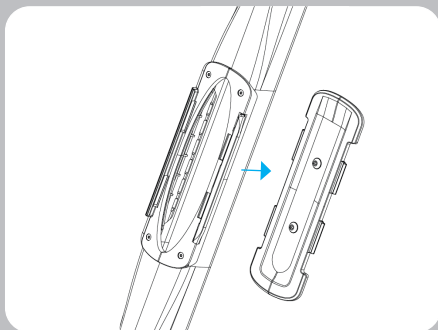

3

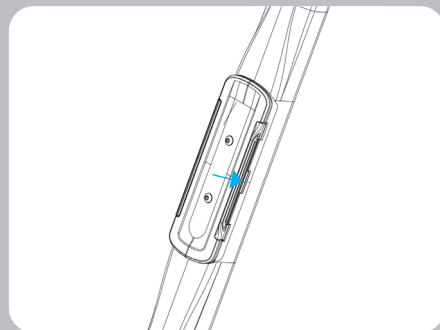

CABLE ROUTING & RUBBER GROMMETS

1. All cables and housing travel through Marin's Series 4 grommets, which are sealed with a rubber membrane to keep out the elements. On the next page is a diagram to help guide you on how the routing is designed through the frame. We recommend only trained, professional bicycle mechanics complete this installation.
2. All cables and housing are clamped in the frame using mounting points under the Bear Box, keeping things rattle-free and tidy.
3. A Marin mud flap keeps out dirt and water.
4. The rubber gasket keeps things rattle-free and protects the frame.

1

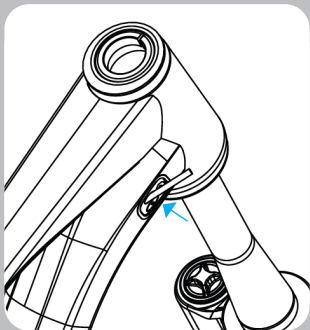

2

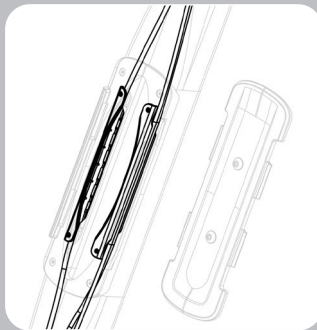

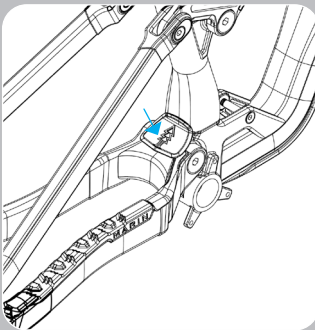

3

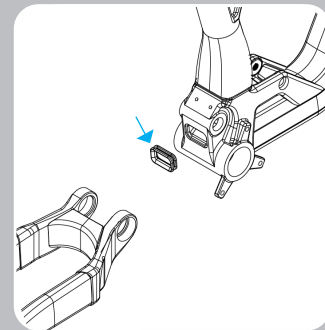

4



INTERNAL CABLE ROUTING

-  **DROPPER**
-  **REAR BRAKE**
-  **REAR DERAILLEUR**

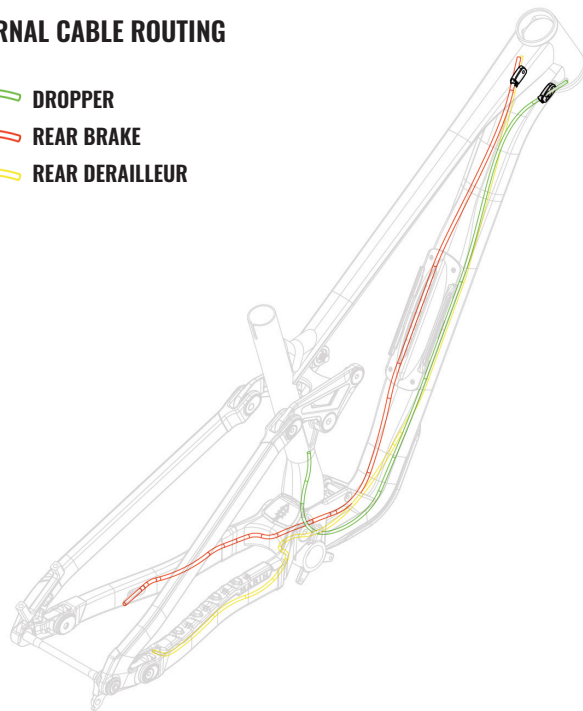

FRAME TECHNICAL SPECIFICATIONS

FORK AXLE TO CROWN

OE Specification 586 mm

MAX 596 mm

*NOT dual crown compatible

SHOCK INFO

Eye to Eye 205 mm

Stroke 65 mm

SHOCK HARDWARE

Upper Trunnion

Lower 30 mm x M8

REAR WHEEL TRAVEL

160 mm

TIRE COMPATIBILITY

Front 29x2.6" MAX TIRE COMPATIBILITY

Rear 2.6" (27.5" stock or 29")

HEADSET SPECIFICATION

FSA Number 76 Marin Specific Design (see page 10 for Marin part number)

Top Bearing FSA MR122

Bottom Bearing FSA MR127

CHAINLINE

52-55 mm

SEAT COLLAR DIAMETER

38.9 mm

REAR BRAKE MOUNT

Post Mount 180 mm

REAR AXLE

148x12 mm

174 mm length, M12 x 1.0 Pitch

BEARING SPECIFICATION QUANTITY

9602 15x28x7 mm 4

6802 15x24x5 mm 4

3802 15x24x7 mm 2

6901 12x24x6 mm 2

SEATPOST DIAMETER

34.9 mm

SEATPOST REAM DEPTH

S 270 mm

M 290 mm

L 300 mm

XL 320 mm

FRAME TECHNICAL SPECIFICATIONS

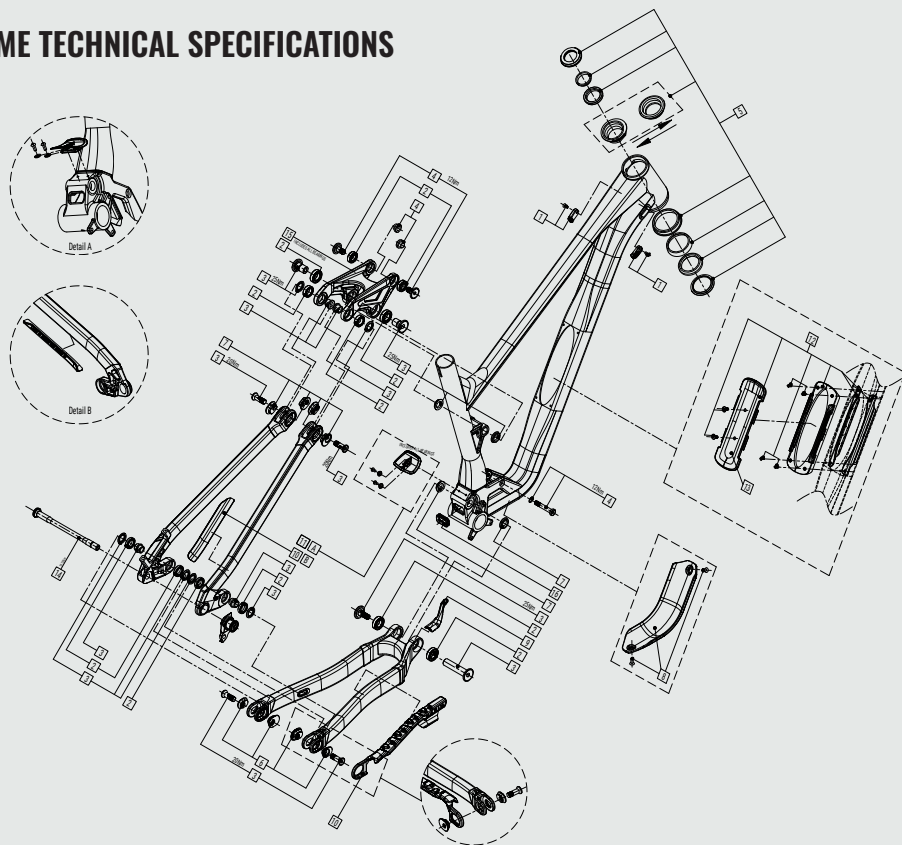

ITEM #	ARTICLE #	DESCRIPTION
1	738410	Series 4 Cable Grommet Kit, Analog Bike
2	738244	Bearing Kit F
3	738242	Pivot Bolt Kit I
4	738243	Shock Bolt Kit I
5	738409	Adjustable Headset Assembly
6	738245	Chainstay Flip Chip Assembly
7	738246	Seatstay/Rocker Flip Chip Assembly
8	738407	DT Protector
9	738404	Alpine Trail CS Yoke Protector
10	738403	Chainstay and Seatstay Protector
11	738406	Alpine Trail Mud Flap with Bolts
12	738401	Bear Box Storage Assembly
13	738402	Bear Box Door Only
14	739302	Bear Box Bag
15	736031	Bolt On Axle Kit 148x12 mm, 174 mm Length, Tapered Head
16	739300	Alpine Trail Rocker Link
17	739317	Cable Grommet for FT Exit Hole

MARIN CUSTOMER SUPPORT

Your local Marin dealer is your best resource for service and repairs, but if you need to contact us directly, visit marinbikes.com/about/contact-us

Warranty

Visit marinbikes.com/support