

# CANTILEVER RACK SELECTION GUIDE

Cantilever racks are ideal for storing long, rigid materials such as lumber, pipe, and bar stock. The racks can be front-loaded by hand or with a fork truck or can be used as side pick racks in space-conscious areas. This guide will help you through the ordering process by providing basic information needed to select cantilever rack. Please call 1-800-338-1382 for more assistance.

## How to Order

A cantilever rack is configured per bay and consists of three general components: arms, columns, and brace sets. There are two common types of cantilever rack: Structural and Roll Formed.

### EXAMPLE:

- 1 Determine storage needs** by taking into account the length, depth, height and weight of the product being stored.
  - 2 Arms:** Choose arm style and length, along with the capacity needed to support the load. Two arms (one on each side) create a "level". Divide the weight of the load per level by two (for one bay) to give the individual arm capacity needed. (This assumes that the load is supported sufficiently by two arms to prevent load deflection).
  - 3 Columns:** Determine the number of arms needed per column side and vertical space required. Adding up all of the individual arm capacities and vertical space required will determine the height and combined weight capacity needed for the two columns.
  - 4 Brace:** Determine brace set width. Take into account the length of the pieces planned to be stored. Brace set widths will provide center-to-center measurements of the arms installed on columns. One brace set per bay is required minimum.
- 1 Product to store:** Lumber at 8' long, 48" deep weighing 3,000 lbs.
  - 2 Arms choice:** 48"L straight. Load weight is 3,000 lbs. Divide weight by two (one level) to obtain 1,500 lbs per arm requirement.
  - 3 Column choice:** Assuming four levels of load are required, then eight arms would be needed with vertical spacing of 36" apart. Eight arms x 1,500 Lbs. capacity per arm = 12,000 lbs (6,000 lbs. per column, single sided) at 16' high would be needed.
  - 4 Brace:** 8'L Load with two arm (one bay) support would require a 4' wide brace set for roll formed cantilever rack or X-Brace panel with a horizontal brace (48" on center) in the case of a structural cantilever rack.
- Also take into account forklift abuse and operator error. Cantilever rack is always a good idea to over design.

### Buying in Complete Sets

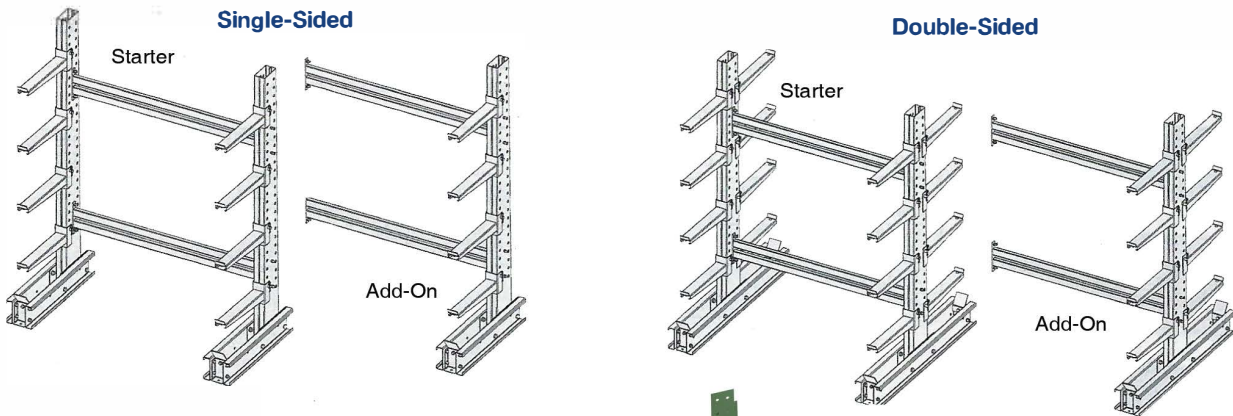

### Buying in Component Parts

