

GETMYUNI

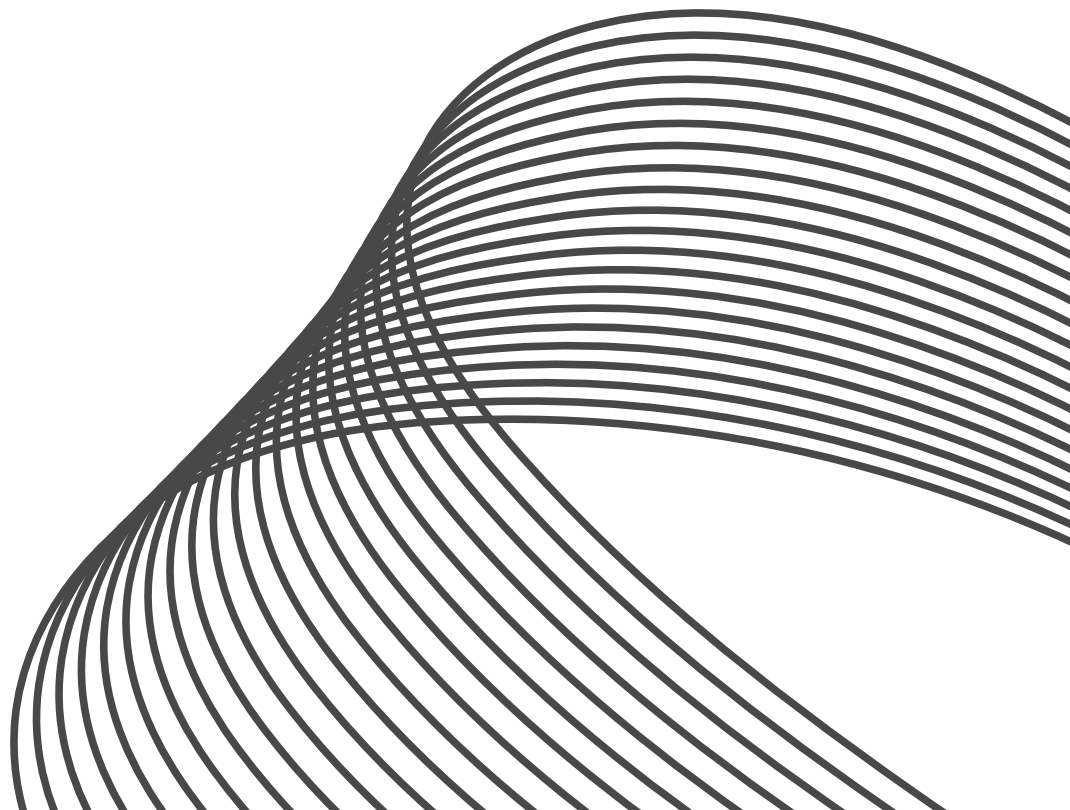

JEE Main

Important Physics
formulas



PHYSICS

FORMULA BOOKLET - GYAAN SUTRA

INDEX

S.No.	Topic	Page No.
1.	Unit and Dimension	2
2.	Rectilinear Motion	3 – 4
3.	Projectile Motion & Vector	5 – 5
4.	Relativve Motion	5 – 7
5.	Newton's Laws of Motion	7 – 9
6.	Friction	9 – 9
7.	Work, Power & Energy	10 – 11
8.	Circular Motion	11 – 14
9.	Centre of Mass	14 – 18
10.	Rigid Body Dynamics	18 – 25
11.	Simple Harmonic Motion	26 – 28
12.	Sting Wave	29 – 31
13.	Heat & Thermodynamics	31 – 37
14.	Electrostatics	37 – 40
15.	Current Electricity	41 – 47
16.	Capacitance	47 – 51
17.	Alternating Current	52 – 54
18.	Magnetic Effect of Current & Magnetic force on charge	54 – 56
19.	Electromagnetic Induction	56 – 59
20.	Geometrical Optics	59 – 66
21.	Modern Physics	67 – 70
22.	Wave Optics	70 – 73
23.	Gravitation	73 – 75
24.	Fluid Mechanics & Properties of Matter	75 – 77
25.	Sound Wave	77 – 79
26.	Electro Magnetic Waves	79 – 80
27.	Error and Measurement	80 – 81
28.	Principle of Communication	82 – 83
29.	Semiconductor	84 – 85

PHYSICS

FORMULA BOOKLET - GYAAN SUTRAA

UNIT AND DIMENSIONS

Unit :

Measurement of any physical quantity is expressed in terms of an internationally accepted certain basic standard called unit.

* Fundamental Units.

S.No.	Physical Quantity	SI Unit	Symbol
1	Length	Metre	m
2	Mass	Kilogram	Kg
3	Time	Second	S
4	Electric Current	Ampere	A
5	Temperature	Kelvin	K
6	Luminous Intensity	Candela	Cd
7	Amount of Substance	Mole	mol

* Supplementary Units :

S.No.	Physical Quantity	SI Unit	Symbol
1	Plane Angle	radian	r
2	Solid Angle	Steradian	Sr

* Metric Prefixes :

S.No.	Prefix	Symbol	Value
1	Centi	c	10^{-2}
2	Mili	m	10^{-3}
3	Micro	μ	10^{-6}
4	Nano	n	10^{-9}
5	Pico	p	10^{-12}
6	Kilo	K	10^3
7	Mega	M	10^6

RECTILINEAR MOTION

Average Velocity (in an interval) :

$$v_{av} = \bar{v} = \langle v \rangle = \frac{\text{Total displacement}}{\text{Total time taken}} = \frac{\vec{r}_f - \vec{r}_i}{\Delta t}$$

Average Speed (in an interval)

$$\text{Average Speed} = \frac{\text{Total distance travelled}}{\text{Total time taken}}$$

Instantaneous Velocity (at an instant) :

$$\vec{v}_{inst} = \lim_{\Delta t \rightarrow 0} \left(\frac{\Delta \vec{r}}{\Delta t} \right)$$

Average acceleration (in an interval):

$$\bar{a}_{av} = \frac{\Delta \bar{v}}{\Delta t} = \frac{\bar{v}_f - \bar{v}_i}{\Delta t}$$

Instantaneous Acceleration (at an instant):

$$\bar{a} = \frac{d\bar{v}}{dt} = \lim_{\Delta t \rightarrow 0} \left(\frac{\Delta \bar{v}}{\Delta t} \right)$$

Graphs in Uniformly Accelerated Motion along a straight line ($a \neq 0$)

- x is a quadratic polynomial in terms of t . Hence $x - t$ graph is a parabola.

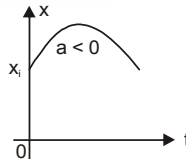
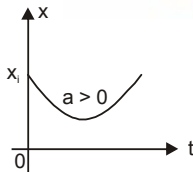

x-t graph

- v is a linear polynomial in terms of t . Hence $v - t$ graph is a straight line of slope a .

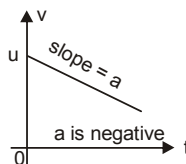
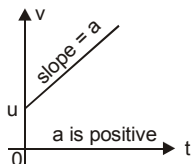

v-t graph

- a-t graph is a horizontal line because a is constant.

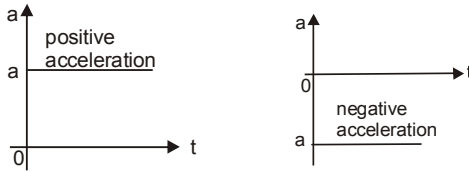

a-t graph

Maxima & Minima

$$\frac{dy}{dx} = 0 \text{ \& \; } \frac{d}{dx} \left(\frac{dy}{dx} \right) < 0 \text{ at maximum}$$

$$\text{and } \frac{dy}{dx} = 0 \text{ \& \; } \frac{d}{dx} \left(\frac{dy}{dx} \right) > 0 \text{ at minima.}$$

Equations of Motion (for constant acceleration)

(a) $v = u + at$

(b) $s = ut + \frac{1}{2} at^2$ $s = vt - \frac{1}{2} at^2$ $x_f = x_i + ut + \frac{1}{2} at^2$

(c) $v^2 = u^2 + 2as$

(d) $s = \frac{(u+v)}{2} t$ (e) $s_n = u + \frac{a}{2} (2n-1)$

For freely falling bodies : ($u = 0$)

(taking upward direction as positive)

(a) $v = -gt$

(b) $s = -\frac{1}{2} gt^2$ $s = vt + \frac{1}{2} gt^2$ $h_f = h_i - \frac{1}{2} gt^2$

(c) $v^2 = -2gs$

(d) $s_n = -\frac{g}{2} (2n-1)$

PROJECTILE MOTION & VECTORS

Time of flight : $T = \frac{2u \sin \theta}{g}$

Horizontal range : $R = \frac{u^2 \sin 2\theta}{g}$

Maximum height : $H = \frac{u^2 \sin^2 \theta}{2g}$

Trajectory equation (equation of path) :

$$y = x \tan \theta - \frac{gx^2}{2u^2 \cos^2 \theta} = x \tan \theta \left(1 - \frac{x}{R}\right)$$

Projection on an inclined plane

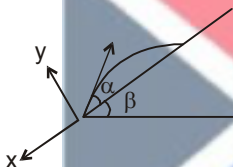

	Up the Incline	Down the Incline
Range	$\frac{2u^2 \sin \alpha \cos(\alpha + \beta)}{g \cos^2 \beta}$	$\frac{2u^2 \sin \alpha \cos(\alpha - \beta)}{g \cos^2 \beta}$
Time of flight	$\frac{2u \sin \alpha}{g \cos \beta}$	$\frac{2u \sin \alpha}{g \cos \beta}$
Angle of projection with incline plane for maximum range	$\frac{\pi}{4} - \frac{\beta}{2}$	$\frac{\pi}{4} + \frac{\beta}{2}$
Maximum Range	$\frac{u^2}{g(1 + \sin \beta)}$	$\frac{u^2}{g(1 - \sin \beta)}$

RELATIVE MOTION

\vec{v}_{AB} (velocity of A with respect to B) = $\vec{v}_A - \vec{v}_B$

\vec{a}_{AB} (acceleration of A with respect to B) = $\vec{a}_A - \vec{a}_B$

Relative motion along straight line - $\vec{x}_{BA} = \vec{x}_B - \vec{x}_A$

CROSSING RIVER

A boat or man in a river always moves in the direction of resultant velocity of velocity of boat (or man) and velocity of river flow.

1. Shortest Time :

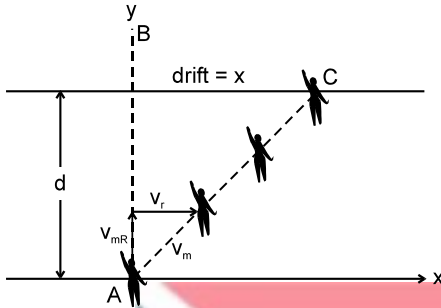

Velocity along the river, $v_x = v_R$

Velocity perpendicular to the river, $v_y = v_{mR}$

The net speed is given by $v_m = \sqrt{v_{mR}^2 + v_R^2}$

2. Shortest Path :

velocity along the river, $v_x = 0$

and velocity perpendicular to river $v_y = \sqrt{v_{mR}^2 - v_R^2}$

The net speed is given by $v_m = \sqrt{v_{mR}^2 - v_R^2}$

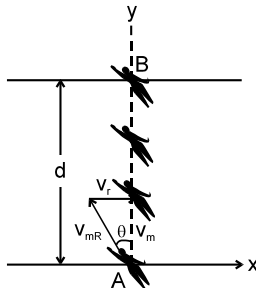

at an angle of 90° with the river direction.

velocity v_y is used only to cross the river,

therefore time to cross the river, $t = \frac{d}{v_y} = \frac{d}{\sqrt{v_{mR}^2 - v_R^2}}$

and velocity v_x is zero, therefore, in this case the drift should be zero.

$$\Rightarrow v_R - v_{mR} \sin \theta = 0 \quad \text{or} \quad v_R = v_{mR} \sin \theta$$

$$\text{or} \quad \theta = \sin^{-1} \left(\frac{v_R}{v_{mR}} \right)$$

RAIN PROBLEMS

$$\vec{v}_{Rm} = \vec{v}_R - \vec{v}_m \quad \text{or} \quad v_{Rm} = \sqrt{v_R^2 + v_m^2}$$

NEWTON'S LAWS OF MOTION

1. From third law of motion

$$\vec{F}_{AB} = -\vec{F}_{BA}$$

\vec{F}_{AB} = Force on A due to B

\vec{F}_{BA} = Force on B due to A

2. From second law of motion

$$F_x = \frac{dP_x}{dt} = ma_x \quad F_y = \frac{dP_y}{dt} = ma_y \quad F_z = \frac{dP_z}{dt} = ma_z$$

5. WEIGHING MACHINE :

A weighing machine does not measure the weight but measures the force exerted by object on its upper surface.

6. SPRING FORCE

$$\vec{F} = -k\vec{x}$$

x is displacement of the free end from its natural length or deformation of the spring where K = spring constant.

7. SPRING PROPERTY $K \times \ell = \text{constant}$

= Natural length of spring.

8. If spring is cut into two in the ratio $m : n$ then spring constant is given by

$$\ell_1 = \frac{m\ell}{m+n}; \quad \ell_2 = \frac{n\ell}{m+n} \quad k\ell = k_1\ell_1 = k_2\ell_2$$

For series combination of springs

$$\frac{1}{k_{eq}} = \frac{1}{k_1} + \frac{1}{k_2} + \dots$$

For parallel combination of spring

$$k_{eq} = k_1 + k_2 + k_3 \dots$$

9. SPRING BALANCE:

It does not measure the weight. It measures the force exerted by the object at the hook.

Remember :

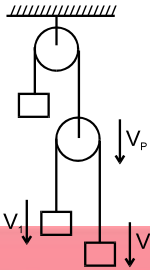

$$V_p = \frac{V_1 + V_2}{2}$$

$$a_p = \frac{a_1 + a_2}{2}$$

11.

$$a = \frac{(m_2 - m_1)g}{m_1 + m_2}$$

$$T = \frac{2m_1m_2g}{m_1 + m_2}$$

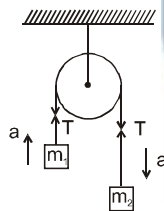

12.

WEDGE CONSTRAINT:

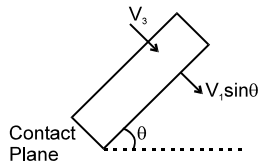
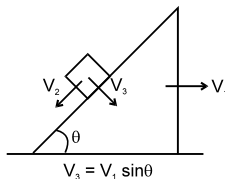

Components of velocity along perpendicular direction to the contact plane of the two objects is always equal if there is no deformations and they remain in contact.

13. NEWTON'S LAW FOR A SYSTEM

$$\vec{F}_{\text{ext}} = m_1 \vec{a}_1 + m_2 \vec{a}_2 + m_3 \vec{a}_3 + \dots$$

\vec{F}_{ext} = Net external force on the system.

m_1, m_2, m_3 are the masses of the objects of the system and $\vec{a}_1, \vec{a}_2, \vec{a}_3$ are the acceleration of the objects respectively.

14. NEWTON'S LAW FOR NON INERTIAL FRAME :

$$\vec{F}_{\text{Real}} + \vec{F}_{\text{Pseudo}} = m \vec{a}$$

Net sum of real and pseudo force is taken in the resultant force.

\vec{a} = Acceleration of the particle in the non inertial frame

$$\vec{F}_{\text{Pseudo}} = - m \vec{a}_{\text{Frame}}$$

(a) Inertial reference frame: Frame of reference moving with constant velocity.

(b) Non-inertial reference frame: A frame of reference moving with non-zero acceleration.

FRICTION

Friction force is of two types.

- (a) Kinetic (b) Static

KINETIC FRICTION : $f_k = \mu_k N$

The proportionality constant μ_k is called the coefficient of kinetic friction and its value depends on the nature of the two surfaces in contact.

STATIC FRICTION :

It exists between the two surfaces when there is tendency of relative motion but no relative motion along the two contact surfaces.

This means static friction is a variable and self adjusting force. However it has a maximum value called limiting friction.

$$f_{\text{max}} = \mu_s N$$

$$0 \leq f_s \leq f_{\text{max}}$$

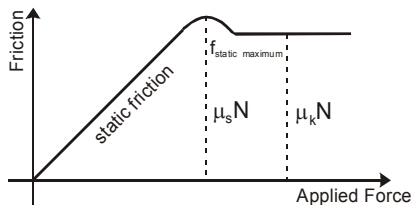
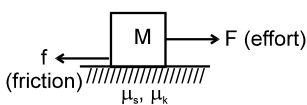

WORK, POWER & ENERGY

WORK DONE BY CONSTANT FORCE :

$$W = \vec{F} \cdot \vec{S}$$

WORK DONE BY MULTIPLE FORCES

$$\Sigma \vec{F} = \vec{F}_1 + \vec{F}_2 + \vec{F}_3 + \dots$$

$$W = [\Sigma \vec{F}] \cdot \vec{S} \quad \dots(i)$$

$$W = \vec{F}_1 \cdot \vec{S} + \vec{F}_2 \cdot \vec{S} + \vec{F}_3 \cdot \vec{S} + \dots$$

or $W = W_1 + W_2 + W_3 + \dots$

WORK DONE BY A VARIABLE FORCE

$$dW = \vec{F} \cdot d\vec{s}$$

RELATION BETWEEN MOMENTUM AND KINETIC ENERGY

$$K = \frac{p^2}{2m} \quad \text{and} \quad P = \sqrt{2mK} \quad ; \quad P = \text{linear momentum}$$

POTENTIAL ENERGY

$$\int_{U_1}^{U_2} dU = - \int_{r_1}^{r_2} \vec{F} \cdot d\vec{r} \quad \text{i.e.,} \quad U_2 - U_1 = - \int_{r_1}^{r_2} \vec{F} \cdot d\vec{r} = -W$$

$$U = - \int_{\infty}^r \vec{F} \cdot d\vec{r} = -W$$

CONSERVATIVE FORCES

$$F = - \frac{\partial U}{\partial r}$$

WORK-ENERGY THEOREM

$$W_C + W_{NC} + W_{PS} = \Delta K$$

Modified Form of Work-Energy Theorem

$$W_C = -\Delta U$$

$$W_{NC} + W_{PS} = \Delta K + \Delta U$$

$$W_{NC} + W_{PS} = \Delta E$$

POWER

The average power (\bar{P} or p_{av}) delivered by an agent is given by \bar{P} or

$$p_{av} = \frac{W}{t}$$

$$P = \frac{\vec{F} \cdot d\vec{S}}{dt} = \vec{F} \cdot \frac{d\vec{S}}{dt} = \vec{F} \cdot \vec{v}$$

CIRCULAR MOTION

1. Average angular velocity $\Rightarrow \omega_{av} = \frac{\theta_2 - \theta_1}{t_2 - t_1} = \frac{\Delta\theta}{\Delta t}$

2. Instantaneous angular velocity $\Rightarrow \omega = \frac{d\theta}{dt}$

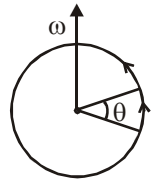

3. Average angular acceleration $\Rightarrow \alpha_{av} = \frac{\omega_2 - \omega_1}{t_2 - t_1} = \frac{\Delta\omega}{\Delta t}$

4. Instantaneous angular acceleration $\Rightarrow \alpha = \frac{d\omega}{dt} = \omega \frac{d\omega}{d\theta}$

5. Relation between speed and angular velocity $\Rightarrow v = r\omega$ and $\vec{v} = \vec{\omega} \times \vec{r}$
 7. Tangential acceleration (rate of change of speed)

$$\Rightarrow a_t = \frac{dv}{dt} = r \frac{d\omega}{dt} = \omega \frac{dr}{dt}$$

8. Radial or normal or centripetal acceleration $\Rightarrow a_r = \frac{v^2}{r} = \omega^2 r$

9. Total acceleration

$$\Rightarrow \vec{a} = \vec{a}_t + \vec{a}_r \Rightarrow a = (a_t^2 + a_r^2)^{1/2}$$

Where $\vec{a}_t = \vec{\alpha} \times \vec{r}$ and $\vec{a}_r = \vec{\omega} \times \vec{v}$

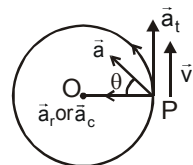

10. Angular acceleration

$$\Rightarrow \vec{\alpha} = \frac{d\vec{\omega}}{dt} \text{ (Non-uniform circular motion)}$$

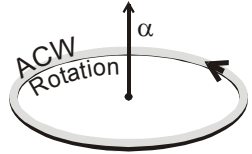

12. Radius of curvature $R = \frac{v^2}{a_{\perp}} = \frac{mv^2}{F_{\perp}}$

If y is a function of x . i.e. $y = f(x) \Rightarrow$

$$R = \frac{\left[1 + \left(\frac{dy}{dx}\right)^2\right]^{3/2}}{d^2y/dx^2}$$

13. Normal reaction of road on a concave bridge

$$\Rightarrow N = mg \cos \theta + \frac{mv^2}{r}$$

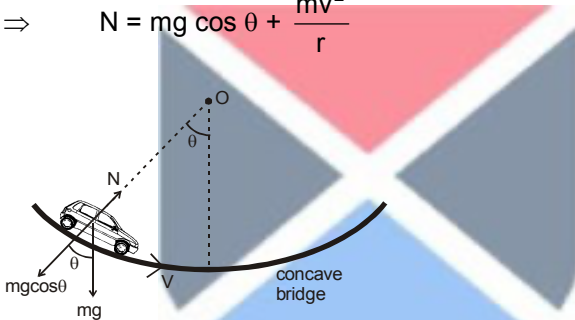

14. Normal reaction on a convex bridge

$$\Rightarrow N = mg \cos \theta - \frac{mv^2}{r}$$

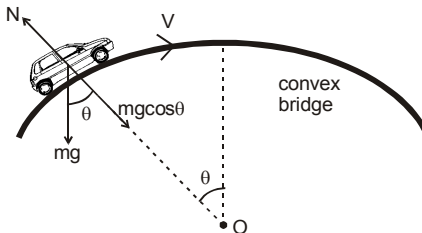

15. Skidding of vehicle on a level road

$$\Rightarrow v_{\text{safe}} \leq \sqrt{\mu g r}$$

16. Skidding of an object on a rotating platform

$$\Rightarrow \omega_{\text{max}} = \sqrt{\mu g / r}$$

17. Bending of cyclist $\Rightarrow \tan \theta = \frac{v^2}{rg}$

18. Banking of road without friction $\Rightarrow \tan \theta = \frac{v^2}{rg}$

19. Banking of road with friction $\Rightarrow \frac{v^2}{rg} = \frac{\mu + \tan \theta}{1 - \mu \tan \theta}$

20. Maximum also minimum safe speed on a banked frictional road

$$V_{\max} = \left[\frac{rg(\mu + \tan \theta)}{(1 - \mu \tan \theta)} \right]^{1/2} \quad V_{\min} = \left[\frac{rg(\tan \theta - \mu)}{(1 + \mu \tan \theta)} \right]^{1/2}$$

21. Centrifugal force (pseudo force) $\Rightarrow f = m\omega^2 r$, acts outwards when the particle itself is taken as a frame.

22. Effect of earth's rotation on apparent weight $\Rightarrow N = mg - mR\omega^2 \cos^2 \theta$;

where $\theta \Rightarrow$ latitude at a place

23. Various quantities for a critical condition in a vertical loop at different positions

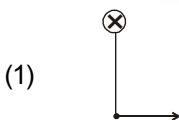
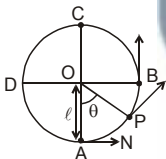

$$V_{\min} = \sqrt{4gL}$$

(for completing the circle)



$$V_{\min} = \sqrt{4gL}$$

(for completing the circle)



$$V_{\min} = \sqrt{4gL}$$

(for completing the circle)

24. Conical pendulum :

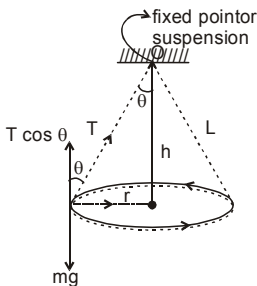

$$T \cos \theta = mg$$

$$T \sin \theta = m\omega^2 r$$

$$\therefore \text{Time period} = 2\pi \sqrt{\frac{L \cos \theta}{g}}$$

25. Relations among angular variables :

$\omega_0 \Rightarrow$ Initial ang. velocity

$$\omega = \omega_0 + \alpha t$$

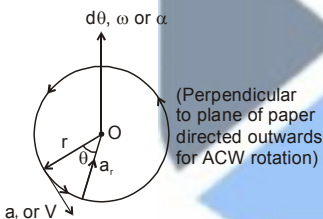

$\omega \Rightarrow$ Find angular velocity

$$\theta = \omega_0 t + \frac{1}{2} \alpha t^2$$

$\omega \Rightarrow$ Const. angular acceleration

$$\omega^2 = \omega_0^2 + 2\alpha \theta$$

$\theta \Rightarrow$ Angular displacement

CENTRE OF MASS

Mass Moment : $\vec{M} = m \vec{r}$

CENTRE OF MASS OF A SYSTEM OF 'N' DISCRETE PARTICLES

$$\vec{r}_{cm} = \frac{m_1 \vec{r}_1 + m_2 \vec{r}_2 + \dots + m_n \vec{r}_n}{m_1 + m_2 + \dots + m_n} ; \vec{r}_{cm}$$

$$= \frac{\sum_{i=1}^n m_i \vec{r}_i}{\sum_{i=1}^n m_i} \vec{r}_{cm} = \frac{1}{M} \sum_{i=1}^n m_i \vec{r}_i$$

CENTRE OF MASS OF A CONTINUOUS MASS DISTRIBUTION

$$x_{cm} = \frac{\int x dm}{\int dm}, \quad y_{cm} = \frac{\int y dm}{\int dm}, \quad z_{cm} = \frac{\int z dm}{\int dm}$$

$\int dm = M$ (mass of the body)

CENTRE OF MASS OF SOME COMMON SYSTEMS

⇒ A system of two point masses $m_1, r_1 = m_2, r_2$

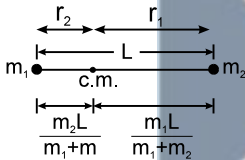

The centre of mass lies closer to the heavier mass.

⇒ Rectangular plate (By symmetry)

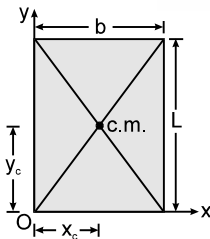

$$x_c = \frac{b}{2} \quad y_c = \frac{L}{2}$$

⇒ A triangular plate (By qualitative argument)

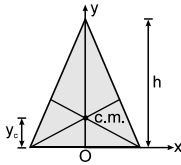

at the centroid : $y_c = \frac{h}{3}$

⇒ A semi-circular ring

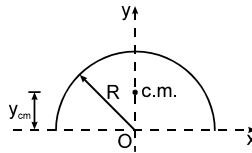

$y_c = \frac{2R}{\pi}$ $x_c = 0$

⇒ A semi-circular disc

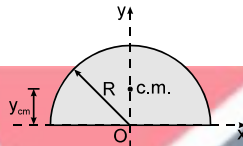

$y_c = \frac{4R}{3\pi}$ $x_c = 0$

⇒ A hemispherical shell

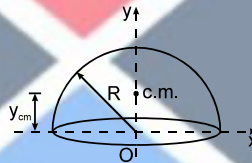

$y_c = \frac{R}{2}$ $x_c = 0$

⇒ A solid hemisphere

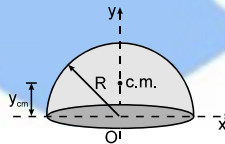

$y_c = \frac{3R}{8}$ $x_c = 0$

⇒ A circular cone (solid)

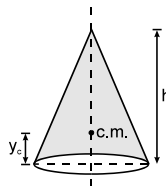

$y_c = \frac{h}{4}$

⇒ A circular cone (hollow)

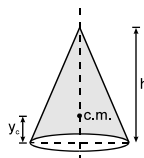

$y_c = \frac{h}{3}$

MOTION OF CENTRE OF MASS AND CONSERVATION OF MOMENTUM:

Velocity of centre of mass of system

$$\vec{v}_{cm} = \frac{m_1 \frac{d\vec{r}_1}{dt} + m_2 \frac{d\vec{r}_2}{dt} + m_3 \frac{d\vec{r}_3}{dt} \dots \dots \dots + m_n \frac{d\vec{r}_n}{dt}}{M}$$

$$= \frac{m_1 \vec{v}_1 + m_2 \vec{v}_2 + m_3 \vec{v}_3 \dots \dots \dots + m_n \vec{v}_n}{M}$$

$$\vec{P}_{System} = M \vec{v}_{cm}$$

Acceleration of centre of mass of system

$$\vec{a}_{cm} = \frac{m_1 \frac{d\vec{v}_1}{dt} + m_2 \frac{d\vec{v}_2}{dt} + m_3 \frac{d\vec{v}_3}{dt} \dots \dots \dots + m_n \frac{d\vec{v}_n}{dt}}{M}$$

$$= \frac{m_1 \vec{a}_1 + m_2 \vec{a}_2 + m_3 \vec{a}_3 \dots \dots \dots + m_n \vec{a}_n}{M}$$

$$= \frac{\text{Net force on system}}{M} = \frac{\text{Net External Force} + \text{Net internal Force}}{M}$$

$$= \frac{\text{Net External Force}}{M}$$

$$\vec{F}_{ext} = M \vec{a}_{cm}$$

IMPULSE

Impulse of a force F action on a body is defined as :-

$$\vec{J} = \int_{t_i}^{t_f} F dt \quad \vec{J} = \Delta \vec{P} \quad (\text{impulse - momentum theorem})$$

Important points :

1. Gravitational force and spring force are always non-impulsive.
2. An impulsive force can only be balanced by another impulsive force.

COEFFICIENT OF RESTITUTION (e)

$$e = \frac{\text{Impulse of reformation}}{\text{Impulse of deformation}} = \frac{\int F_r dt}{\int F_d dt}$$

$$= \frac{\text{Velocity of separation along line of impact}}{\text{Velocity of approach along line of impact}}$$

- (a) $e = 1$ \Rightarrow Impulse of Reformation = Impulse of Deformation
 \Rightarrow Velocity of separation = Velocity of approach
 \Rightarrow Kinetic Energy may be conserved
 \Rightarrow Elastic collision.
- (b) $e = 0$ \Rightarrow Impulse of Reformation = 0
 \Rightarrow Velocity of separation = 0
 \Rightarrow Kinetic Energy is not conserved
 \Rightarrow Perfectly Inelastic collision.
- (c) $0 < e < 1$ \Rightarrow Impulse of Reformation < Impulse of Deformation
 \Rightarrow Velocity of separation < Velocity of approach
 \Rightarrow Kinetic Energy is not conserved
 \Rightarrow Inelastic collision.

VARIABLE MASS SYSTEM :

If a mass is added or ejected from a system, at rate μ kg/s and relative velocity \vec{v}_{rel} (w.r.t. the system), then the force exerted by this mass on the system has magnitude $\mu |\vec{v}_{rel}|$.

Thrust Force (\vec{F}_t)

$$\vec{F}_t = \vec{v}_{rel} \left(\frac{dm}{dt} \right)$$

Rocket propulsion :

If gravity is ignored and initial velocity of the rocket $u = 0$;

$$v = v_r \ln \left(\frac{m_0}{m} \right).$$

RIGID BODY DYNAMICS

1. RIGID BODY :

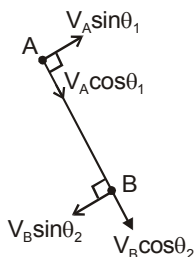
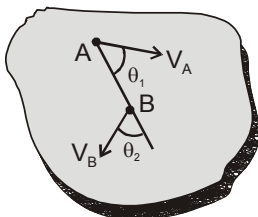

If the above body is rigid

$$V_A \cos \theta_1 = V_B \cos \theta_2$$

V_{BA} = relative velocity of point B with respect to point A.

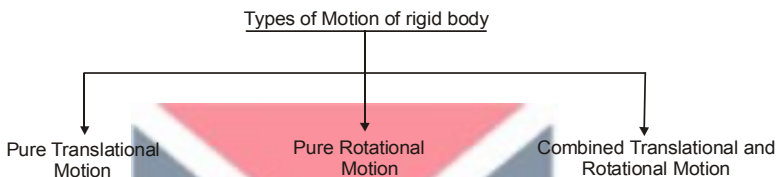

2. MOMENT OF INERTIA (I) :

Definition : Moment of Inertia is defined as the capability of system to oppose the change produced in the rotational motion of a body.

Moment of Inertia is a scalar positive quantity.

$$I = m_1 r_1^2 + m_2 r_2^2 + \dots$$

$$= I_1 + I_2 + I_3 + \dots$$

SI units of Moment of Inertia is Kgm^2 .

Moment of Inertia of :

2.1 A single particle : $I = mr^2$

where m = mass of the particle

r = perpendicular distance of the particle from the axis about which moment of Inertia is to be calculated

2.2 For many particles (system of particles) :

$$I = \sum_{i=1}^n m_i r_i^2$$

2.3 For a continuous object :

$$I = \int dm r^2$$

where dm = mass of a small element

r = perpendicular distance of the particle from the axis

2.4 For a larger object :

$$I = \int dI_{\text{element}}$$

where dI = moment of inertia of a small element

3. TWO IMPORTANT THEOREMS ON MOMENT OF INERTIA :

3.1 Perpendicular Axis Theorem

[Only applicable to plane lamina (that means for 2-D objects only)].



$$I_z = I_x + I_y \quad (\text{when object is in x-y plane}).$$

3.2 Parallel Axis Theorem

(Applicable to any type of object):

$$I_{AB} = I_{\text{cm}} + Md^2$$

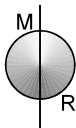
List of some useful formula :

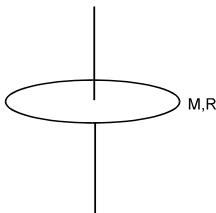
Object	Moment of Inertia
 Solid Sphere	$\frac{2}{5} MR^2$ (Uniform)
 Hollow Sphere	$\frac{2}{3} MR^2$ (Uniform)
	MR^2 (Uniform or Non Uniform)

Ring.

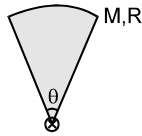
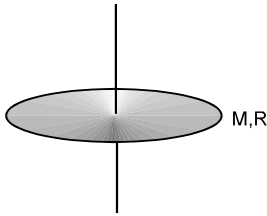

$$\frac{MR^2}{2} \text{ (Uniform)}$$

Disc

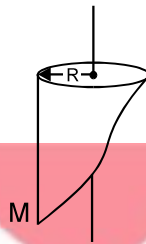
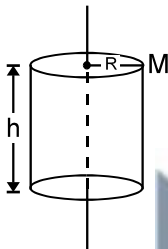

$$MR^2 \text{ (Uniform or Non Uniform)}$$

Hollow cylinder

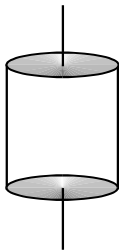

$$\frac{MR^2}{2} \text{ (Uniform)}$$

Solid cylinder

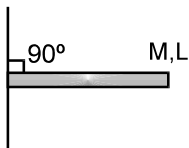

$$\frac{ML^2}{3} \text{ (Uniform)}$$

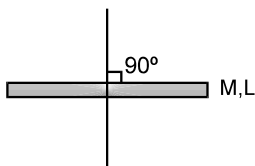

$$\frac{ML^2}{12} \text{ (Uniform)}$$

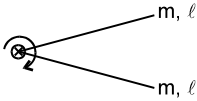

$$\frac{2m\ell^2}{3} \text{ (Uniform)}$$

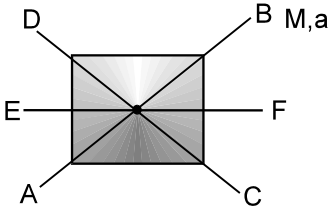

$$I_{AB} = I_{CD} = I_{EF} = \frac{Ma^2}{12} \text{ (Uniform)}$$

Square Plate

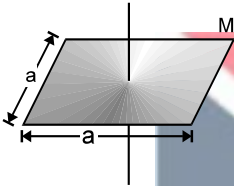

$$\frac{Ma^2}{6} \text{ (Uniform)}$$

Square Plate

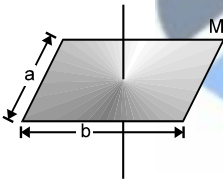

$$I = \frac{M(a^2 + b^2)}{12} \text{ (Uniform)}$$

Rectangular Plate

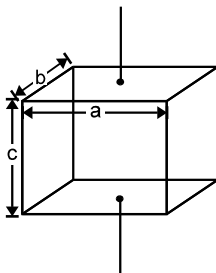

$$\frac{M(a^2 + b^2)}{12} \text{ (Uniform)}$$

Cuboid

4. **RADIUS OF GYRATION :**

$$I = MK^2$$

5. **TORQUE :**

$$\vec{\tau} = \vec{r} \times \vec{F}$$

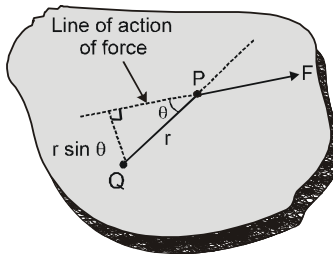

5.5 Relation between 'τ' & 'α' (for hinged object or pure rotation)

$$\vec{\tau}_{\text{ext}})_{\text{Hinge}} = I_{\text{Hinge}} \vec{\alpha}$$

Where $\vec{\tau}_{\text{ext}})_{\text{Hinge}}$ = net external torque acting on the body about Hinge point

I_{Hinge} = moment of Inertia of body about Hinge point

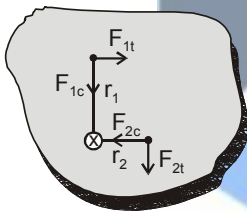

$$F_{1t} = M_1 a_{1t} = M_1 r_1 \alpha$$

$$F_{2t} = M_2 a_{2t} = M_2 r_2 \alpha$$

$$\tau_{\text{resultant}} = F_{1t} r_1 + F_{2t} r_2 + \dots$$

$$= M_1 \alpha r_1^2 + M_2 \alpha r_2^2 + \dots$$

$$\tau_{\text{resultant}})_{\text{external}} = I \alpha$$

$$\text{Rotational Kinetic Energy} = \frac{1}{2} I \omega^2$$

$$\vec{P} = M \vec{v}_{\text{CM}} \Rightarrow \vec{F}_{\text{external}} = M \vec{a}_{\text{CM}}$$

Net external force acting on the body has two parts tangential and centripetal.

$$\Rightarrow F_c = m a_c = m \frac{v^2}{r_{\text{CM}}} = m \omega^2 r_{\text{CM}} \Rightarrow F_t = m a_t = m \alpha r_{\text{CM}}$$

6. ROTATIONAL EQUILIBRIUM :

For translational equilibrium.

$$\Sigma F_x = 0 \quad \dots\dots\dots (i)$$

and $\Sigma F_y = 0 \quad \dots\dots\dots (ii)$

The condition of rotational equilibrium is

$$\Sigma \Gamma_z = 0$$

7. ANGULAR MOMENTUM (\vec{L})

7.1 Angular momentum of a particle about a point.

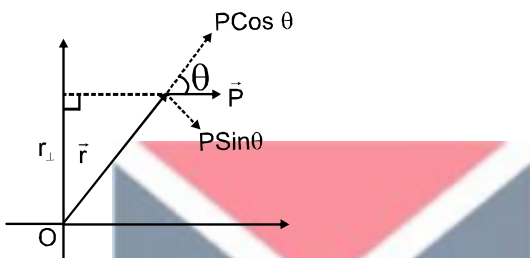

$$\vec{L} = \vec{r} \times \vec{P}$$

$$\Rightarrow L = r p \sin \theta$$

$$|\vec{L}| = r_{\perp} \times P$$

$$|\vec{L}| = P_{\perp} \times r$$

7.3 Angular momentum of a rigid body rotating about fixed axis :

$$\vec{L}_H = I_H \vec{\omega}$$

L_H = angular momentum of object about axis H.

I_H = Moment of Inertia of rigid object about axis H.

ω = angular velocity of the object.

7.4 Conservation of Angular Momentum

Angular momentum of a particle or a system remains constant if

$\tau_{\text{ext}} = 0$ about that point or axis of rotation.

7.5 Relation between Torque and Angular Momentum

$$\vec{\tau} = \frac{d\vec{L}}{dt}$$

Torque is change in angular momentum

7.6 Impulse of Torque :

$$\int \tau dt = \Delta J \quad \Delta J \rightarrow \text{Change in angular momentum.}$$

For a rigid body, the distance between the particles remain unchanged during its motion i.e. $r_{P/Q} = \text{constant}$

For velocities

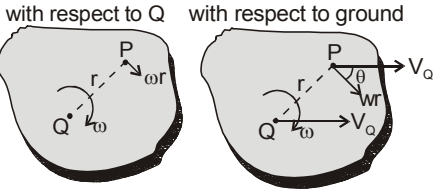

$$V_P = \sqrt{V_Q^2 + (\omega r)^2 + 2 V_Q \omega r \cos \theta}$$

For acceleration :

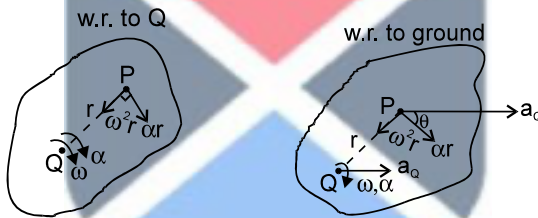

θ , ω , α are same about every point of the body (or any other point outside which is rigidly attached to the body).

Dynamics :

$$\vec{\tau}_{cm} = I_{cm} \vec{\alpha}, \quad \vec{F}_{ext} = M \vec{a}_{cm}$$

$$\vec{P}_{system} = M \vec{v}_{cm},$$

$$\text{Total K.E.} = \frac{1}{2} M v_{cm}^2 + \frac{1}{2} I_{cm} \omega^2$$

Angular momentum axis AB = \vec{L} about C.M. + \vec{L} of C.M. about AB

$$\vec{L}_{AB} = I_{cm} \vec{\omega} + \vec{r}_{cm} \times M \vec{v}_{cm}$$

SIMPLE HARMONIC MOTION

S.H.M.

$$F = -kx$$

General equation of S.H.M. is $x = A \sin(\omega t + \phi)$; $(\omega t + \phi)$ is phase of the motion and ϕ is initial phase of the motion.

Angular Frequency (ω) :
$$\omega = \frac{2\pi}{T} = 2\pi f$$

Time period (T) :
$$T = \frac{2\pi}{\omega} = 2\pi\sqrt{\frac{m}{k}}$$



Speed :

$$v = \omega\sqrt{A^2 - x^2}$$

Acceleration :

$$a = -\omega^2 x$$

Kinetic Energy (KE) :

$$\frac{1}{2} mv^2 = \frac{1}{2} m\omega^2 (A^2 - x^2) = \frac{1}{2} k (A^2 - x^2)$$

Potential Energy (PE) :

$$\frac{1}{2} Kx^2$$

Total Mechanical Energy (TME)

$$= \text{K.E.} + \text{P.E.} = \frac{1}{2} k (A^2 - x^2) + \frac{1}{2} Kx^2 = \frac{1}{2} KA^2 \text{ (which is constant)}$$

SPRING-MASS SYSTEM

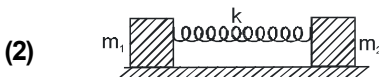
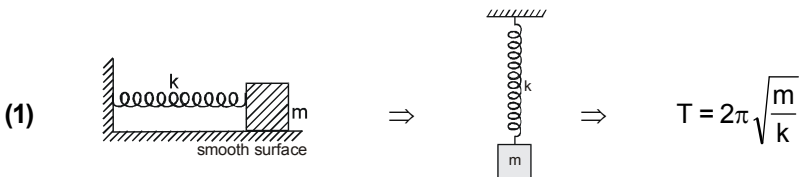

$$T = 2\pi\sqrt{\frac{\mu}{K}}, \text{ where } \mu = \frac{m_1 m_2}{(m_1 + m_2)} \text{ known as reduced mass}$$

COMBINATION OF SPRINGS

Series Combination :

$$1/k_{eq} = 1/k_1 + 1/k_2$$

Parallel combination :

$$k_{eq} = k_1 + k_2$$

SIMPLE PENDULUM $T = 2\pi \sqrt{\frac{\ell}{g}} = 2\pi \sqrt{\frac{\ell}{g_{eff}}}$ (in accelerating Refer-

ence Frame); g_{eff} is net acceleration due to pseudo force and gravitational force.

COMPOUND PENDULUM / PHYSICAL PENDULUM

Time period (T) : $T = 2\pi \sqrt{\frac{I}{mg\ell}}$

where, $I = I_{CM} + m\ell^2$; ℓ is distance between point of suspension and centre of mass.

TORSIONAL PENDULUM

Time period (T) : $T = 2\pi \sqrt{\frac{I}{C}}$ where, C = Torsional constant

Superposition of SHM's along the same direction

$$x_1 = A_1 \sin \omega t \quad \& \quad x_2 = A_2 \sin (\omega t + \theta)$$

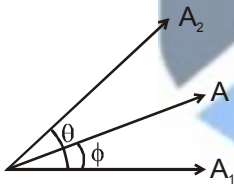

If equation of resultant SHM is taken as $x = A \sin (\omega t + \phi)$

$$A = \sqrt{A_1^2 + A_2^2 + 2A_1A_2 \cos \theta} \quad \& \quad \tan \phi = \frac{A_2 \sin \theta}{A_1 + A_2 \cos \theta}$$

1. Damped Oscillation

• Damping force

$$\vec{F} = -b\vec{v}$$

• equation of motion is

$$\frac{mdv}{dt} = -kx - bv$$

• $b^2 - 4mK > 0$ over damping

- $b^2 - 4mK = 0$ critical damping
- $b^2 - 4mK < 0$ under damping
- For small damping the solution is of the form.

$$x = (A_0 e^{-bt/2m}) \sin [\omega' t + \delta], \text{ where } \omega' = \sqrt{\left(\frac{k}{m}\right) - \left(\frac{b}{2m}\right)^2}$$

For small b

- angular frequency $\omega' \approx \sqrt{k/m}, = \omega_0$

- Amplitude $A = A_0 e^{\frac{-bt}{2m}}$

- Energy $E(t) = \frac{1}{2} K A^2 e^{-bt/m}$

- Quality factor or Q value, $Q = 2\pi \frac{E}{|\Delta E|} = \frac{\omega'}{2\omega_Y}$

where, $\omega' = \sqrt{\frac{k}{m} - \frac{b^2}{4m^2}}$, $\omega_Y = \frac{b}{2m}$

2. Forced Oscillations And Resonance

External Force $F(t) = F_0 \cos \omega_d t$

$x(t) = A \cos (\omega_d t + \phi)$

$$A = \frac{F_0}{\sqrt{\left(m^2 (\omega^2 - \omega_d^2)^2 + \omega_d^2 b^2\right)}} \text{ and } \tan \phi = \frac{-v_0}{\omega_d x_0}$$

(a) Small Damping $A = \frac{F_0}{m(\omega^2 - \omega_d^2)}$

(b) Driving Frequency Close to Natural Frequency $A = \frac{F_0}{\omega_d b}$

STRING WAVES

GENERAL EQUATION OF WAVE MOTION :

$$\frac{\partial^2 y}{\partial t^2} = v^2 \frac{\partial^2 y}{\partial x^2}$$

$$y(x,t) = f\left(t \pm \frac{x}{v}\right)$$

where, $y(x, t)$ should be finite everywhere.

$$\Rightarrow f\left(t + \frac{x}{v}\right) \text{ represents wave travelling in - ve x-axis.}$$

$$\Rightarrow f\left(t - \frac{x}{v}\right) \text{ represents wave travelling in + ve x-axis.}$$

$$y = A \sin(\omega t \pm kx + \phi)$$

TERMS RELATED TO WAVE MOTION (FOR 1-D PROGRESSIVE SINE WAVE)

(e) Wave number (or propagation constant) (k) :

$$k = 2\pi/\lambda = \frac{\omega}{v} \text{ (rad m}^{-1}\text{)}$$

(f) Phase of wave : The argument of harmonic function $(\omega t \pm kx + \phi)$ is called phase of the wave.

Phase difference $(\Delta\phi)$: difference in phases of two particles at any time t .

$$\Delta\phi = \frac{2\pi}{\lambda} \Delta x \quad \text{Also. } \Delta\phi = \frac{2\pi}{T} \cdot \Delta t$$

SPEED OF TRANSVERSE WAVE ALONG A STRING/WIRE.

$$v = \sqrt{\frac{T}{\mu}} \quad \text{where } \begin{array}{l} T = \text{Tension} \\ \mu = \text{mass per unit length} \end{array}$$

POWER TRANSMITTED ALONG THE STRING BY A SINE WAVE

$$\text{Average Power } \langle P \rangle = 2\pi^2 f^2 A^2 \mu v$$

$$\text{Intensity } I = \frac{\langle P \rangle}{s} = 2\pi^2 f^2 A^2 \rho v$$

REFLECTION AND REFRACTION OF WAVES

$$y_i = A_i \sin(\omega t - k_1 x)$$

$$\left. \begin{array}{l} y_t = A_t \sin(\omega t - k_2 x) \\ y_r = -A_r \sin(\omega t + k_1 x) \end{array} \right\} \text{ if incident from rarer to denser medium } (v_2 < v_1)$$

$$\left. \begin{aligned} y_t &= A_t \sin(\omega t - k_2 x) \\ y_r &= A_r \sin(\omega t + k_1 x) \end{aligned} \right\} \text{if incident from denser to rarer medium. } (v_2 > v_1)$$

(d) Amplitude of reflected & transmitted waves.

$$A_r = \frac{|k_1 - k_2|}{k_1 + k_2} A_i \quad \& \quad A_t = \frac{2k_1}{k_1 + k_2} A_i$$

STANDING/STATIONARY WAVES :-

(b) $y_1 = A \sin(\omega t - kx + \theta_1)$

$y_2 = A \sin(\omega t + kx + \theta_2)$

$$y_1 + y_2 = \left[2A \cos\left(kx + \frac{\theta_2 - \theta_1}{2}\right) \right] \sin\left(\omega t + \frac{\theta_1 + \theta_2}{2}\right)$$

The quantity $2A \cos\left(kx + \frac{\theta_2 - \theta_1}{2}\right)$ represents resultant amplitude at x . At some position resultant amplitude is zero these are called **nodes**. At some positions resultant amplitude is $2A$, these are called **antinodes**.

(c) Distance between successive nodes or antinodes = $\frac{\lambda}{2}$.

(d) Distance between successive nodes and antinodes = $\lambda/4$.

(e) All the particles in same segment (portion between two successive nodes) vibrate in same phase.

(f) The particles in two consecutive segments vibrate in opposite phase.

(g) Since nodes are permanently at rest so energy can not be transmitted across these.

VIBRATIONS OF STRINGS (STANDING WAVE)

(a) Fixed at both ends :

1. Fixed ends will be nodes. So waves for which

$$L = \frac{\lambda}{2}$$

$$L = \frac{2\lambda}{2}$$

$$L = \frac{3\lambda}{2}$$

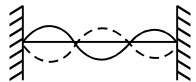
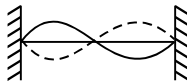

are possible giving

$$L = \frac{n\lambda}{2}$$

$$\text{or } \lambda = \frac{2L}{n} \text{ where } n = 1, 2, 3, \dots$$

as $v = \sqrt{\frac{T}{\mu}}$

$$f_n = \frac{n}{2L} \sqrt{\frac{T}{\mu}}, \quad n = \text{no. of loops}$$

(b) String free at one end :

1. for fundamental mode $L = \frac{\lambda}{4}$ = or $\lambda = 4L$

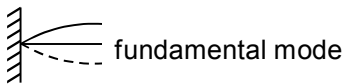

First overtone $L = \frac{3\lambda}{4}$ Hence $\lambda = \frac{4L}{3}$



so $f_1 = \frac{3}{4L} \sqrt{\frac{T}{\mu}}$ (First overtone)

Second overtone $f_2 = \frac{5}{4L} \sqrt{\frac{T}{\mu}}$

so $f_n = \frac{\left(n + \frac{1}{2}\right)}{2L} \sqrt{\frac{T}{\mu}} = \frac{(2n+1)}{4L} \sqrt{\frac{T}{\mu}}$

HEAT & THERMODYNAMICS

Total translational K.E. of gas = $\frac{1}{2} M \langle V^2 \rangle = \frac{3}{2} PV = \frac{3}{2} nRT$

$$\langle V^2 \rangle = \frac{3P}{\rho} \quad V_{\text{rms}} = \sqrt{\frac{3P}{\rho}} = \sqrt{\frac{3RT}{M_{\text{mol}}}} = \sqrt{\frac{3KT}{m}}$$

Important Points :

$$- V_{\text{rms}} \propto \sqrt{T} \quad \bar{V} = \sqrt{\frac{8KT}{\pi m}} = 1.59 \sqrt{\frac{KT}{m}} \quad V_{\text{rms}} = 1.73 \sqrt{\frac{KT}{m}}$$

Most probable speed $V_p = \sqrt{\frac{2KT}{m}} = 1.41 \sqrt{\frac{KT}{m}} \therefore V_{\text{rms}} > \bar{V} > V_{\text{mp}}$

Degree of freedom :

Mono atomic $f = 3$

Diatomic $f = 5$

polyatomic $f = 6$

Maxwell's law of equipartition of energy :Total K.E. of the molecule = $\frac{1}{2} f KT$

For an ideal gas :

Internal energy $U = \frac{f}{2} nRT$

Workdone in isothermal process : $W = [2.303 nRT \log_{10} \frac{V_f}{V_i}]$

Internal energy in isothermal process : $\Delta U = 0$

Work done in isochoric process : $dW = 0$

Change in int. energy in isochoric process :

$$\Delta U = n \frac{f}{2} R \Delta T = \text{heat given}$$

Isobaric process :

Work done $\Delta W = nR(T_f - T_i)$

change in int. energy $\Delta U = nC_V \Delta T$

heat given $\Delta Q = \Delta U + \Delta W$

Specific heat : $C_V = \frac{f}{2} R$ $C_p = \left(\frac{f}{2} + 1\right) R$

Molar heat capacity of ideal gas in terms of R :

(i) for monoatomic gas : $\frac{C_p}{C_v} = 1.67$

(ii) for diatomic gas : $\frac{C_p}{C_v} = 1.4$

(iii) for triatomic gas : $\frac{C_p}{C_v} = 1.33$

In general : $\gamma = \frac{C_p}{C_v} = \left[1 + \frac{2}{f}\right]$

Mayer's eq. $\Rightarrow C_p - C_v = R$ for ideal gas only

Adiabatic process :

Work done $\Delta W = \frac{nR(T_i - T_f)}{\gamma - 1}$

In cyclic process :

$$\Delta Q = \Delta W$$

In a mixture of non-reacting gases :

$$\text{Mol. wt.} = \frac{n_1 M_1 + n_2 M_2}{n_1 + n_2}$$

$$C_v = \frac{n_1 C_{v_1} + n_2 C_{v_2}}{n_1 + n_2}$$

$$\gamma = \frac{C_{p(\text{mix})}}{C_{v(\text{mix})}} = \frac{n_1 C_{p_1} + n_2 C_{p_2} + \dots}{n_1 C_{v_1} + n_2 C_{v_2} + \dots}$$

Heat Engines

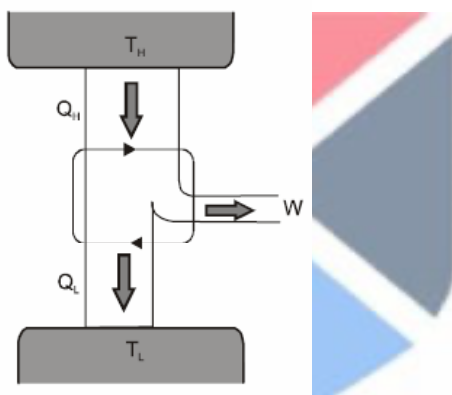

Efficiency, $\eta = \frac{\text{work done by the engine}}{\text{heat supplied to it}}$

$$= \frac{W}{Q_H} = \frac{Q_H - Q_L}{Q_H} = 1 - \frac{Q_L}{Q_H}$$

Second law of Thermodynamics

• Kelvin- Planck Statement

It is impossible to construct an engine, operating in a cycle, which will produce no effect other than extracting heat from a reservoir and performing an equivalent amount of work.

• Rudlope Classius Statement

It is impossible to make heat flow from a body at a lower temperature to a body at a higher temperature without doing external work on the working substance

Entropy

- change in entropy of the system is $\Delta S = \frac{\Delta Q}{T} \Rightarrow S_f - S_i = \int_i^f \frac{\Delta Q}{T}$

- In an adiabatic reversible process, entropy of the system remains constant.

Efficiency of Carnot Engine

- (1) Operation I (Isothermal Expansion)
- (2) Operation II (Adiabatic Expansion)
- (3) Operation III (Isothermal Compression)
- (4) Operation IV (Adiabatic Compression)

Thermal Efficiency of a Carnot engine

$$\frac{V_2}{V_1} = \frac{V_3}{V_4} \Rightarrow \frac{Q_2}{Q_1} = \frac{T_2}{T_1} \Rightarrow \eta = 1 - \frac{T_2}{T_1}$$

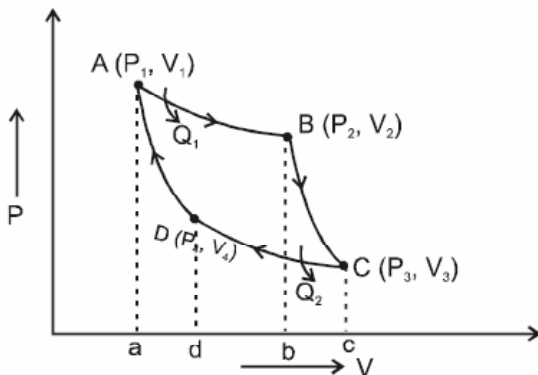

Refrigerator (Heat Pump)

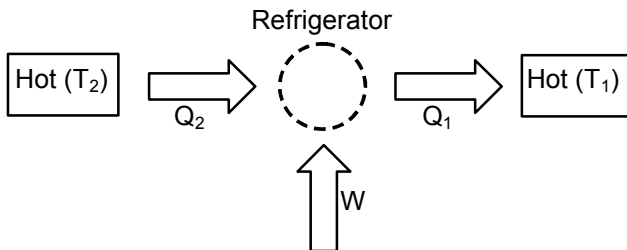

• Coefficient of performance, $\beta = \frac{Q_2}{W} = \frac{1}{\frac{T_1}{T_2} - 1} = \frac{1}{\frac{T_1}{T_2} - 1}$

Calorimetry and thermal expansion

Types of thermometers :

(a) Liquid Thermometer : $T = \left[\frac{l - l_0}{l_{100} - l_0} \right] \times 100$

(b) Gas Thermometer :

Constant volume : $T = \left[\frac{P - P_0}{P_{100} - P_0} \right] \times 100$; $P = P_0 + \rho g h$

Constant Pressure : $T = \left[\frac{V}{V - V'} \right] T_0$

(c) Electrical Resistance Thermometer :

$$T = \left[\frac{R_t - R_0}{R_{100} - R_0} \right] \times 100$$

Thermal Expansion :

(a) Linear :

$$\alpha = \frac{\Delta L}{L_0 \Delta T} \quad \text{or} \quad L = L_0 (1 + \alpha \Delta T)$$

(b) Area/superficial :

$$\beta = \frac{\Delta A}{A_0 \Delta T} \quad \text{or} \quad A = A_0 (1 + \beta \Delta T)$$

(c) volume/ cubical :

$$\gamma = \frac{\Delta V}{V_0 \Delta T} \quad \text{or} \quad V = V_0 (1 + \gamma \Delta T)$$

$$\alpha = \frac{\beta}{2} = \frac{\gamma}{3}$$

Thermal stress of a material :

$$\frac{F}{A} = Y \frac{\Delta \ell}{\ell}$$

Energy stored per unit volume :

$$E = \frac{1}{2} K(\Delta L)^2 \quad \text{or} \quad E = \frac{1}{2} \frac{AY}{L} (\Delta L)^2$$

Variation of time period of pendulum clocks :

$$\Delta T = \frac{1}{2} \alpha \Delta \theta T$$

$T' < T$ - clock-fast : time-gain

$T' > T$ - clock slow : time-loss

CALORIMETRY :

$$\text{Specific heat } S = \frac{Q}{m \cdot \Delta T}$$

$$\text{Molar specific heat } C = \frac{\Delta Q}{n \cdot \Delta T}$$

$$\text{Water equivalent} = m_w S_w$$

HEAT TRANSFER

$$\text{Thermal Conduction :} \quad \frac{dQ}{dt} = -KA \frac{dT}{dx}$$

$$\text{Thermal Resistance :} \quad R = \frac{\ell}{KA}$$

Series and parallel combination of rod :

(i) **Series :** $\frac{l_{eq}}{K_{eq}} = \frac{l_1}{K_1} + \frac{l_2}{K_2} + \dots$ (when $A_1 = A_2 = A_3 = \dots$)

(ii) **Parallel :** $K_{eq} A_{eq} = K_1 A_1 + K_2 A_2 + \dots$ (when $l_1 = l_2 = l_3 = \dots$)

for absorption, reflection and transmission

$$r + t + a = 1$$

Emissive power : $E = \frac{\Delta U}{\Delta A \Delta t}$

Spectral emissive power : $E_\lambda = \frac{dE}{d\lambda}$

Emissivity : $e = \frac{E \text{ of a body at } T \text{ temp.}}{E \text{ of a black body at } T \text{ temp.}}$

Kirchoff's law : $\frac{E(\text{body})}{a(\text{body})} = E(\text{black body})$

Wein's Displacement law : $\lambda_m \cdot T = b$
 $b = 0.282 \text{ cm-k}$

Stefan Boltzmann law :

$$u = \sigma T^4 \quad s = 5.67 \times 10^{-8} \text{ W/m}^2 \text{ K}^4$$
$$\Delta u = u - u_0 = e \sigma A (T^4 - T_0^4)$$

Newton's law of cooling : $\frac{d\theta}{dt} = k(\theta - \theta_0)$; $\theta = \theta_0 + (\theta_i - \theta_0) e^{-kt}$

ELECTROSTATICS

Coulomb force between two point charges

$$\vec{F} = \frac{1}{4\pi\epsilon_0\epsilon_r} \frac{q_1q_2}{|\vec{r}|^3} \vec{r} = \frac{1}{4\pi\epsilon_0\epsilon_r} \frac{q_1q_2}{|\vec{r}|^2} \hat{r}$$

- **The electric field intensity at any point is the force experienced by unit positive charge, given by $\vec{E} = \frac{\vec{F}}{q_0}$**
- **Electric force on a charge 'q' at the position of electric field intensity \vec{E} produced by some source charges is $\vec{F} = q\vec{E}$**
- **Electric Potential**

If $(W_{\infty P})_{\text{ext}}$ is the work required in moving a point charge q from infinity to a point P, the electric potential of the point P is

$$V_p = \frac{(W_{\infty p})_{\text{ext}}}{q} \Big]_{\text{acc}=0}$$

- **Potential Difference between two points A and B is**

$$V_A - V_B$$

- **Formulae of \vec{E} and potential V**

(i) Point charge $E = \frac{Kq}{|\vec{r}|^2} \cdot \hat{r} = \frac{Kq}{r^3} \vec{r}, V = \frac{Kq}{r}$

(ii) Infinitely long line charge $\frac{\lambda}{2\pi\epsilon_0 r} \hat{r} = \frac{2K\lambda \hat{r}}{r}$
 $V = \text{not defined}, v_B - v_A = -2K\lambda \ln(r_B / r_A)$

(iii) Infinite nonconducting thin sheet $\frac{\sigma}{2\epsilon_0} \hat{n}$,
 $V = \text{not defined}, v_B - v_A = -\frac{\sigma}{2\epsilon_0} (r_B - r_A)$

(iv) Uniformly charged ring
 $E_{\text{axis}} = \frac{KQx}{(R^2 + x^2)^{3/2}}, E_{\text{centre}} = 0$
 $V_{\text{axis}} = \frac{KQ}{\sqrt{R^2 + x^2}}, V_{\text{centre}} = \frac{KQ}{R}$
 x is the distance from centre along axis.

(v) Infinitely large charged conducting sheet $\frac{\sigma}{\epsilon_0} \hat{n}$
 $V = \text{not defined}, v_B - v_A = -\frac{\sigma}{\epsilon_0} (r_B - r_A)$

- (vi) Uniformly charged hollow conducting/ nonconducting /solid conducting sphere

(a) for $\vec{E} = \frac{kQ}{|\vec{r}|^2} \hat{r}, r \geq R, V = \frac{KQ}{r}$

(b) $\vec{E} = 0$ for $r < R, V = \frac{KQ}{R}$

(vii) Uniformly charged solid nonconducting sphere (insulating material)

(a) $\vec{E} = \frac{kQ}{|\vec{r}|^2} \hat{r}$ for $r \geq R$, $V = \frac{KQ}{r}$

(b) $\vec{E} = \frac{KQ\vec{r}}{R^3} = \frac{\rho\vec{r}}{3\epsilon_0}$ for $r \leq R$, $V = \frac{\rho}{6\epsilon_0} (3R^2 - r^2)$

(viii) thin uniformly charged disc (surface charge density is σ)

$$E_{\text{axis}} = \frac{\sigma}{2\epsilon_0} \left[1 - \frac{x}{\sqrt{R^2 + x^2}} \right] \quad V_{\text{axis}} = \frac{\sigma}{2\epsilon_0} \left[\sqrt{R^2 + x^2} - x \right]$$

- **Work done by external agent in taking a charge q from A to B is**
 $(W_{\text{ext}})_{AB} = q(V_B - V_A)$ or $(W_{\text{el}})_{AB} = q(V_A - V_B)$.

- **The electrostatic potential energy of a point charge**
 $U = qV$

- **U = PE of the system =**

$$\frac{U_1 + U_2 + \dots}{2} = (U_{12} + U_{13} + \dots + U_{1n}) + (U_{23} + U_{24} + \dots + U_{2n}) \\ + (U_{34} + U_{35} + \dots + U_{3n}) \dots$$

- **Energy Density =** $\frac{1}{2} \epsilon E^2$

- **Self Energy of a uniformly charged shell =** $U_{\text{self}} = \frac{KQ^2}{2R}$

- **Self Energy of a uniformly charged solid non-conducting sphere**

$$= U_{\text{self}} = \frac{3KQ^2}{5R}$$

- **Electric Field Intensity Due to Dipole**

(i) on the axis $\vec{E} = \frac{2K\vec{P}}{r^3}$

(ii) on the equatorial position : $\vec{E} = -\frac{K\vec{P}}{r^3}$

(iii) Total electric field at general point O (r, θ) is $E_{\text{res}} = \frac{KP}{r^3} \sqrt{1 + 3\cos^2 \theta}$

- **Potential Energy of an Electric Dipole in External Electric Field:**

$$U = - \vec{p} \cdot \vec{E}$$

- **Electric Dipole in Uniform Electric Field :**

$$\text{torque } \vec{\tau} = \vec{p} \times \vec{E}; \quad \vec{F} = 0$$

- **Electric Dipole in Nonuniform Electric Field:**

$$\text{torque } \vec{\tau} = \vec{p} \times \vec{E}; \quad U = - \vec{p} \cdot \vec{E}, \quad \text{Net force } |F| = \left| p \frac{\partial E}{\partial r} \right|$$

- **Electric Potential Due to Dipole at General Point (r, θ) :**

$$V = \frac{P \cos \theta}{4\pi\epsilon_0 r^2} = \frac{\vec{p} \cdot \vec{r}}{4\pi\epsilon_0 r^3}$$

- **The electric flux over the whole area is given by**

$$\phi_E = \int_S \vec{E} \cdot d\vec{S} = \int_S E_n dS$$

- **Flux using Gauss's law, Flux through a closed surface**

$$\phi_E = \oint \vec{E} \cdot d\vec{S} = \frac{q_{in}}{\epsilon_0}$$

- **Electric field intensity near the conducting surface**

$$= \frac{\sigma}{\epsilon_0} \hat{n}$$

- **Electric pressure :** Electric pressure at the surface of a conductor is given by formula

$$P = \frac{\sigma^2}{2\epsilon_0} \quad \text{where } \sigma \text{ is the local surface charge density.}$$

- **Potential difference between points A and B**

$$V_B - V_A = - \int_A^B \vec{E} \cdot d\vec{r}$$

$$\begin{aligned} \vec{E} &= - \left[\hat{i} \frac{\partial}{\partial x} V + \hat{j} \frac{\partial}{\partial y} V + \hat{k} \frac{\partial}{\partial z} V \right] = - \left[\hat{i} \frac{\partial}{\partial x} + \hat{j} \frac{\partial}{\partial y} + \hat{k} \frac{\partial}{\partial z} \right] V \\ &= - \nabla V = -\text{grad } V \end{aligned}$$

CURRENT ELECTRICITY

1. ELECTRIC CURRENT

$$I_{av} = \frac{\Delta q}{\Delta t} \text{ and instantaneous current}$$

$$i = \lim_{\Delta t \rightarrow 0} \frac{\Delta q}{\Delta t} = \frac{dq}{dt}$$

2. ELECTRIC CURRENT IN A CONDUCTOR

$$I = nAeV_d$$

$$V_d = \frac{\lambda}{\tau}$$

$$V_d = \frac{\frac{1}{2} \left(\frac{eE}{m} \right) \tau^2}{\tau} = \frac{1}{2} \frac{eE}{m} \tau$$

$$I = neAV_d$$

3. CURRENT DENSITY

$$\vec{J} = \frac{dI}{ds} \vec{n}$$

4. ELECTRICAL RESISTANCE

$$I = neAV_d = neA \left(\frac{eE}{2m} \right) \tau = \left(\frac{ne^2\tau}{2m} \right) AE$$

$$E = \frac{V}{\ell} \text{ so } I = \left(\frac{ne^2\tau}{2m} \right) \left(\frac{A}{\ell} \right) V = \left(\frac{A}{\rho\ell} \right) V = V/R \Rightarrow V = IR$$

ρ is called resistivity (it is also called specific resistance) and

$\rho = \frac{2m}{ne^2\tau} = \frac{1}{\sigma}$, σ is called conductivity. Therefore current in conductors

is proportional to potential difference applied across its ends. This is **Ohm's Law**.

Units:

$R \rightarrow \text{ohm}(\Omega)$, $\rho \rightarrow \text{ohm-meter}(\Omega\text{-m})$

also called siemens, $\sigma \rightarrow \Omega^{-1}\text{m}^{-1}$.

Dependence of Resistance on Temperature :

$$R = R_0 (1 + \alpha \theta).$$

Electric current in resistance

$$I = \frac{V_2 - V_1}{R}$$

5. ELECTRICAL POWER

$$P = VI$$

$$\text{Energy} = \int pdt$$

$$P = I^2R = VI = \frac{V^2}{R}$$

$$H = VIt = I^2Rt = \frac{V^2}{R}t$$

$$H = I^2RT \text{ Joule} = \frac{I^2RT}{4.2} \text{ Calorie}$$

9. KIRCHHOFF'S LAWS

9.1 Kirchhoff's Current Law (Junction law)

$$\sum I_{\text{in}} = \sum I_{\text{out}}$$

9.2 Kirchhoff's Voltage Law (Loop law)

$$\sum IR + \sum \text{EMF} = 0$$

10. COMBINATION OF RESISTANCES :

Resistances in Series:

$R = R_1 + R_2 + R_3 + \dots + R_n$ (this means R_{eq} is greater than any resistor) and

$$V = V_1 + V_2 + V_3 + \dots + V_n$$

$$V_1 = \frac{R_1}{R_1 + R_2 + \dots + R_n} V ; V_2 = \frac{R_2}{R_1 + R_2 + \dots + R_n} V ;$$

2. Resistances in Parallel :

$$\boxed{\frac{1}{R_{\text{eq}}} = \frac{1}{R_1} + \frac{1}{R_2} + \frac{1}{R_3}}$$

11. WHEATSTONE NETWORK : (4 TERMINAL NETWORK)

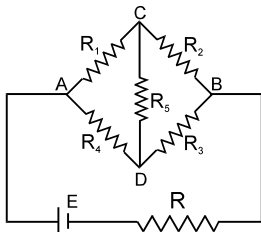

When current through the galvanometer is zero (null point or balance

point) $\frac{P}{Q} = \frac{R}{S}$, then $PS = QR$

13. GROUPING OF CELLS

13.1 Cells in Series :

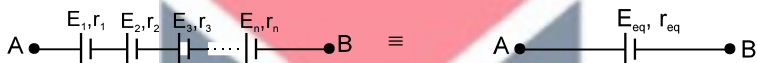

Equivalent EMF $E_{eq} = E_1 + E_2 + \dots + E_n$ [write EMF's with polarity]

Equivalent internal resistance $r_{eq} = r_1 + r_2 + r_3 + r_4 + \dots + r_n$

13.2 Cells in Parallel:

$$E_{eq} = \frac{\frac{\epsilon_1}{r_1} + \frac{\epsilon_2}{r_2} + \dots + \frac{\epsilon_n}{r_n}}{\frac{1}{r_1} + \frac{1}{r_2} + \dots + \frac{1}{r_n}} \quad \text{[Use emf with polarity]}$$

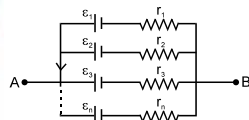

$$\frac{1}{r_{eq}} = \frac{1}{r_1} + \frac{1}{r_2} + \dots + \frac{1}{r_n}$$

15. AMMETER

A shunt (small resistance) is connected in parallel with galvanometer to convert it into ammeter. An ideal ammeter has zero resistance

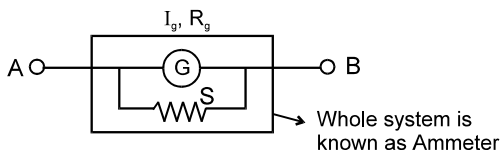

Ammeter is represented as follows -

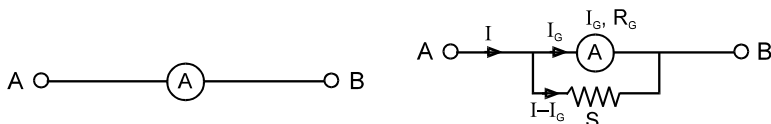

If maximum value of current to be measured by ammeter is I then

$$I_G \cdot R_G = (I - I_G)S$$

$$S = \frac{I_G \cdot R_G}{I - I_G} \quad S = \frac{I_G \times R_G}{I} \quad \text{when } I \gg I_G.$$

where I = Maximum current that can be measured using the given ammeter.

16. VOLTMETER

A high resistance is put in series with galvanometer. It is used to measure potential difference across a resistor in a circuit.

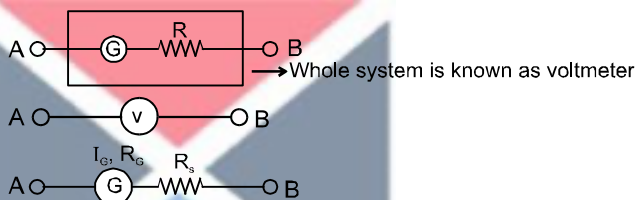

For maximum potential difference

$$V = I_G \cdot R_s + I_G R_G$$

$$R_s = \frac{V}{I_G} - R_G \quad \text{if } R_G \ll R_s \Rightarrow R_s \approx \frac{V}{I_G}$$

17. POTENTIOMETER

$$I = \frac{\varepsilon}{r + R}$$

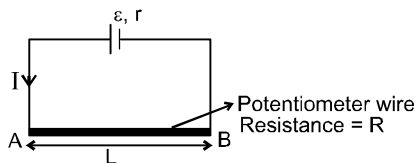

$$V_A - V_B = \frac{\varepsilon}{R + r} \cdot R$$

Potential gradient (x) → Potential difference per unit length of wire

$$x = \frac{V_A - V_B}{L} = \frac{\varepsilon}{R + r} \cdot \frac{R}{L}$$

Application of potentiometer

(a) To find emf of unknown cell and compare emf of two cells.

In case I,

In figure (1) is joint to (2) then balance length = l_1

$$\varepsilon_1 = x l_1 \quad \dots(1)$$

in case II,

In figure (3) is joint to (2) then balance length = l_2

$$\varepsilon_2 = x l_2 \quad \dots(2)$$

$$\frac{\varepsilon_1}{\varepsilon_2} = \frac{l_1}{l_2}$$

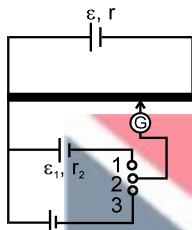

If any one of ε_1 or ε_2 is known the other can be found. If x is known then both ε_1 and ε_2 can be found

(b) To find current if resistance is known

$$V_A - V_C = x l_1$$

$$I R_1 = x l_1$$

$$I = \frac{x l_1}{R_1}$$

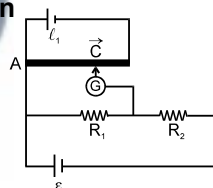

Similarly, we can find the value of R_2 also.

Potentiometer is ideal voltmeter because it does not draw any current from circuit, at the balance point.

(c) To find the internal resistance of cell.

1st arrangement

2nd arrangement

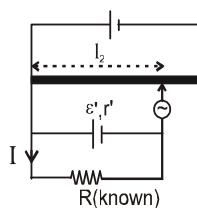
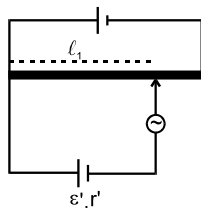

by first arrangement $\varepsilon' = x\ell_1$... (1)
 by second arrangement $IR = x\ell_2$

$$I = \frac{x\ell_2}{R}, \quad \text{also } I = \frac{\varepsilon'}{r'+R}$$

$$\therefore \frac{\varepsilon'}{r'+R} = \frac{x\ell_2}{R} \quad \Rightarrow \quad \frac{x\ell_1}{r'+R} = \frac{x\ell_2}{R}$$

$$r' = \left[\frac{\ell_1 - \ell_2}{\ell_2} \right] R$$

(d) Ammeter and voltmeter can be graduated by potentiometer.

(e) Ammeter and voltmeter can be calibrated by potentiometer.

18. METRE BRIDGE (USE TO MEASURE UNKNOWN RESISTANCE)

If $AB = \ell$ cm, then $BC = (100 - \ell)$ cm.

Resistance of the wire between A and B, $R \propto \ell$

[\because Specific resistance ρ and cross-sectional area A are same for whole of the wire]

$$\text{or } R = \sigma \ell \quad \dots (1)$$

where σ is resistance per cm of wire.

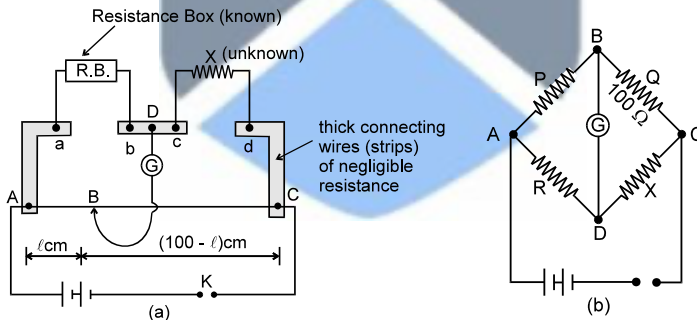

If P is the resistance of wire between A and B then

$$P \propto \ell \quad \Rightarrow \quad P = \sigma(\ell)$$

Similarly, if Q is resistance of the wire between B and C, then

$$Q \propto 100 - \ell$$

$$\therefore Q = \sigma(100 - \ell) \quad \dots (2)$$

Dividing (1) by (2),

$$\frac{P}{Q} = \frac{\ell}{100 - \ell}$$

Applying the condition for balanced Wheatstone bridge, we get $R Q = P X$

$$\therefore x = R \frac{Q}{P} \quad \text{or} \quad X = \frac{100 - \ell}{\ell} R$$

Since R and ℓ are known, therefore, the value of X can be calculated.

CAPACITANCE

1. (i) $q \propto V \Rightarrow q = CV$
 q : Charge on positive plate of the capacitor
 C : Capacitance of capacitor.
 V : Potential difference between positive and negative plates.

- (ii) Representation of capacitor : $-| | - , -| (-$

- (iii) Energy stored in the capacitor : $U = \frac{1}{2} CV^2 = \frac{Q^2}{2C} = \frac{QV}{2}$

- (iv) Energy density = $\frac{1}{2} \epsilon_0 \epsilon_r E^2 = \frac{1}{2} \epsilon_0 K E^2$

ϵ_r = Relative permittivity of the medium.

$K = \epsilon_r$: Dielectric Constant

For vacuum, energy density = $\frac{1}{2} \epsilon_0 E^2$

- (v) Types of Capacitors :

(a) Parallel plate capacitor

$$C = \frac{\epsilon_0 \epsilon_r A}{d} = K \frac{\epsilon_0 A}{d}$$

A : Area of plates

d : distance between the plates (\ll size of plate)

(b) Spherical Capacitor :

- Capacitance of an isolated spherical Conductor (hollow or solid)

$$C = 4\pi \epsilon_0 \epsilon_r R$$

R = Radius of the spherical conductor

- Capacitance of spherical capacitor

$$C = 4\pi \epsilon_0 \frac{ab}{(b-a)}$$



- $C = \frac{4\pi \epsilon_0 K_1 K_2 ab}{(b-a)}$

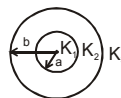

(c) **Cylindrical Capacitor :** $l \gg \{a, b\}$

$$\text{Capacitance per unit length} = \frac{2\pi\epsilon_0}{\ln(b/a)} \text{ F/m}$$

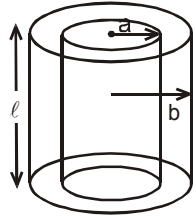

- (vi) Capacitance of capacitor depends on
 (a) Area of plates
 (b) Distance between the plates
 (c) Dielectric medium between the plates.
- (vii) Electric field intensity between the plates of capacitor

$$E = \frac{\sigma}{\epsilon_0} = \frac{V}{d}$$

σ : Surface charge density

- (viii) Force experienced by any plate of capacitor : $F = \frac{q^2}{2A\epsilon_0}$

2. DISTRIBUTION OF CHARGES ON CONNECTING TWO CHARGED CAPACITORS:

When two capacitors are C_1 and C_2 are connected as shown in figure



- (a) Common potential :

$$\Rightarrow V = \frac{C_1 V_1 + C_2 V_2}{C_1 + C_2} = \frac{\text{Total charge}}{\text{Total capacitance}}$$

$$(b) \quad Q_1' = C_1 V = \frac{C_1}{C_1 + C_2} (Q_1 + Q_2)$$

$$Q_2' = C_2 V = \frac{C_2}{C_1 + C_2} (Q_1 + Q_2)$$

(c) Heat loss during redistribution :

$$\Delta H = U_i - U_f = \frac{1}{2} \frac{C_1 C_2}{C_1 + C_2} (V_1 - V_2)^2$$

The loss of energy is in the form of Joule heating in the wire.

3. Combination of capacitor :

(i) Series Combination

$$\frac{1}{C_{eq}} = \frac{1}{C_1} + \frac{1}{C_2} + \frac{1}{C_3} \quad V_1 : V_2 : V_3 = \frac{1}{C_1} : \frac{1}{C_2} : \frac{1}{C_3}$$

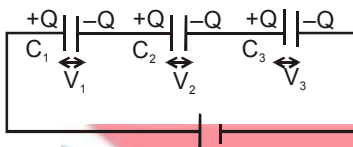

(ii) Parallel Combination :

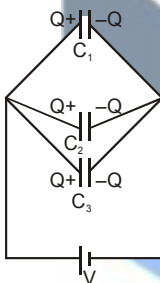

$$C_{eq} = C_1 + C_2 + C_3 \quad Q_1 : Q_2 : Q_3 = C_1 : C_2 : C_3$$

4. Charging and Discharging of a capacitor :

(i) Charging of Capacitor (Capacitor initially uncharged):

$$q = q_0 (1 - e^{-t/\tau})$$

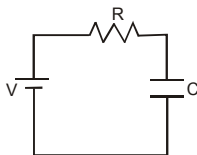

q_0 = Charge on the capacitor at steady state

$$q_0 = CV$$

τ : Time constant = CR_{eq} .

$$I = \frac{q_0}{\tau} e^{-t/\tau} = \frac{V}{R} e^{-t/\tau}$$

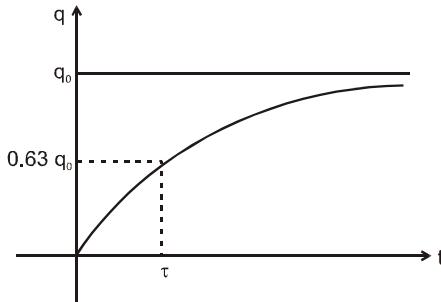

(ii) Discharging of Capacitor :

$$q = q_0 e^{-t/\tau}$$

q_0 = Initial charge on the capacitor

$$I = \frac{q_0}{\tau} e^{-t/\tau}$$

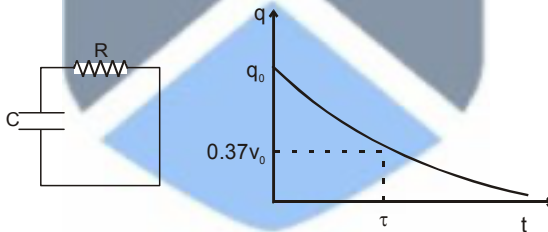

5. Capacitor with dielectric :

(i) Capacitance in the presence of dielectric :

$$C = \frac{K\epsilon_0 A}{d} = KC_0$$

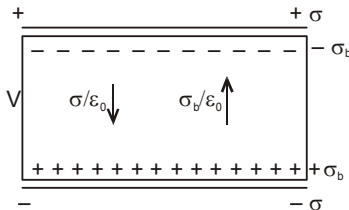

C_0 = Capacitance in the absence of dielectric.

$$(ii) \quad E_{in} = E - E_{ind} = \frac{\sigma}{\epsilon_0} - \frac{\sigma_b}{\epsilon_0} = \frac{\sigma}{K\epsilon_0} = \frac{V}{d}$$

E : $\frac{\sigma}{\epsilon_0}$ Electric field in the absence of dielectric

E_{ind} : Induced (bound) charge density.

$$(iii) \quad \sigma_b = \sigma \left(1 - \frac{1}{K}\right).$$

6. Force on dielectric

(i) When battery is connected $F = \frac{\epsilon_0 b(K-1)V^2}{2d}$

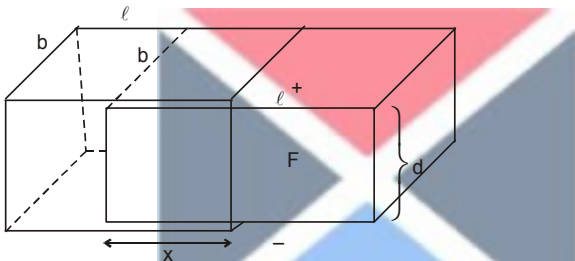

(ii) When battery is not connected $F = \frac{Q^2}{2C^2} \frac{dC}{dx}$

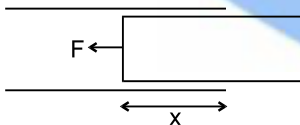

* Force on the dielectric will be zero when the dielectric is fully inside.

ALTERNATING CURRENT

1. AC AND DC CURRENT :

A current that changes its direction periodically is called alternating current (AC). If a current maintains its direction constant it is called direct current (DC).

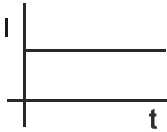

constant dc

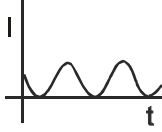

periodic dc

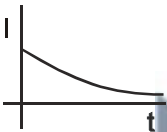

variable dc

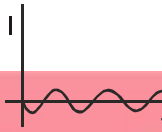

ac

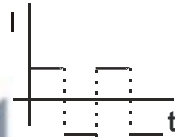

ac

3. ROOT MEAN SQUARE VALUE:

Root Mean Square Value of a function, from t_1 to t_2 , is defined as

$$f_{\text{rms}} = \sqrt{\frac{\int_{t_1}^{t_2} f^2 dt}{t_2 - t_1}}$$

4. POWER CONSUMED OR SUPPLIED IN AN AC CIRCUIT:

$$\text{Average power consumed in a cycle} = \frac{\int_0^{2\pi} P dt}{2\pi} = \frac{1}{2} V_m I_m \cos \phi$$

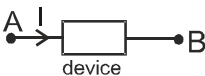

$$= \frac{V_m}{\sqrt{2}} \cdot \frac{I_m}{\sqrt{2}} \cdot \cos \phi = V_{\text{rms}} I_{\text{rms}} \cos \phi$$

Here $\cos \phi$ is called **power factor**.

5. **SOME DEFINITIONS:**

The factor $\cos \phi$ is called **Power factor**.

$I_m \sin \phi$ is called **wattless current**.

Impedance Z is defined as $Z = \frac{V_m}{I_m} = \frac{V_{rms}}{I_{rms}}$

ωL is called **inductive reactance** and is denoted by X_L .

$\frac{1}{\omega C}$ is called **capacitive reactance** and is denoted by X_C .

6. **PURELY RESISTIVE CIRCUIT:**

$$I = \frac{v_s}{R} = \frac{V_m \sin \omega t}{R} = I_m \sin \omega t$$

$$I_m = \frac{V_m}{R}$$

$$I_{rms} = \frac{V_{rms}}{R}$$

$$\langle P \rangle = V_{rms} I_{rms} \cos \phi = \frac{V_{rms}^2}{R}$$

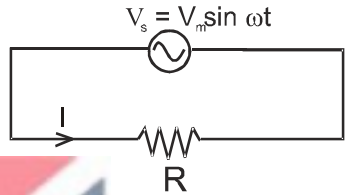

7. **PURELY CAPACITIVE CIRCUIT:**

$$I = \frac{V_m}{\frac{1}{\omega C}} \cos \omega t$$

$$= \frac{V_m}{X_C} \cos \omega t = I_m \cos \omega t.$$

$X_C = \frac{1}{\omega C}$ and is called capacitive reactance.

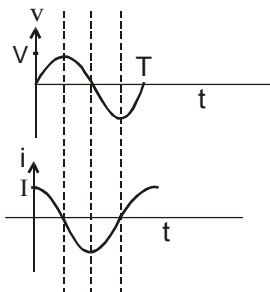
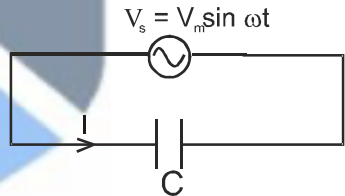

I_c leads by v_c by $\pi/2$ Diagrammatically (phasor diagram) it is represented as



Since $\phi = 90^\circ$, $\langle P \rangle = V_{rms} I_{rms} \cos \phi = 0$

MAGNETIC EFFECT OF CURRENT & MAGNETIC FORCE ON CHARGE/CURRENT

1. Magnetic field due to a moving point charge

$$\vec{B} = \frac{\mu_0}{4\pi} \cdot \frac{q(\vec{v} \times \vec{r})}{r^3}$$

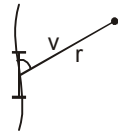

2. Biot-savart's Law

$$d\vec{B} = \frac{\mu_0 I}{4\pi} \cdot \left(\frac{d\vec{\ell} \times \vec{r}}{r^3} \right)$$

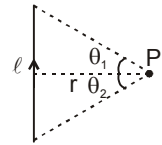

3. Magnetic field due to a straight wire

$$B = \frac{\mu_0}{4\pi} \frac{I}{r} (\sin \theta_1 + \sin \theta_2)$$

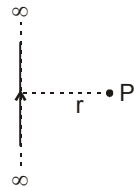

4. Magnetic field due to infinite straight wire

$$B = \frac{\mu_0}{2\pi} \frac{I}{r}$$

5. Magnetic field due to circular loop

(i) At centre

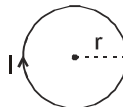

$$B = \frac{\mu_0 NI}{2r}$$

(ii) At Axis

$$B = \frac{\mu_0}{2} \left(\frac{NIR^2}{(R^2 + x^2)^{3/2}} \right)$$

6. **Magnetic field on the axis of the solenoid**

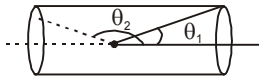

$$B = \frac{\mu_0 n I}{2} (\cos \theta_1 - \cos \theta_2)$$

7. **Ampere's Law**



$$\oint \vec{B} \cdot d\vec{\ell} = \mu_0 I$$

8. **Magnetic field due to long cylindrical shell**

$$B = 0, r < R$$

$$= \frac{\mu_0 I}{2\pi r}, r \geq R$$

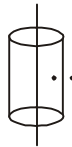

9. **Magnetic force acting on a moving point charge**

a. $\vec{F} = q(\vec{v} \times \vec{B})$

(i) $\vec{v} \perp \vec{B}$

$$r = \frac{mv}{qB}$$

$$T = \frac{2\pi m}{qB}$$

(ii)

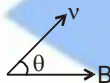

$$r = \frac{mv \sin \theta}{qB}$$

$$T = \frac{2\pi m}{qB}$$

$$\text{Pitch} = \frac{2\pi m v \cos \theta}{qB}$$

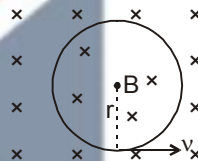

b. $\vec{F} = q[(\vec{v} \times \vec{B}) + \vec{E}]$

10. **Magnetic force acting on a current carrying wire**

$$\vec{F} = I(\vec{\ell} \times \vec{B})$$

11. **Magnetic Moment of a current carrying loop**

$$M = N \cdot I \cdot A$$

12. **Torque acting on a loop**

$$\vec{\tau} = \vec{M} \times \vec{B}$$

13. Magnetic field due to a single pole

$$B = \frac{\mu_0 \cdot m}{4\pi r^2}$$

14. Magnetic field on the axis of magnet

$$B = \frac{\mu_0}{4\pi} \cdot \frac{2M}{r^3}$$

15. Magnetic field on the equatorial axis of the magnet

$$B = \frac{\mu_0}{4\pi} \cdot \frac{M}{r^3}$$

16. Magnetic field at point P due to magnet

$$B = \frac{\mu_0}{4\pi} \frac{M}{r^3} \sqrt{1 + 3\cos^2 \theta}$$

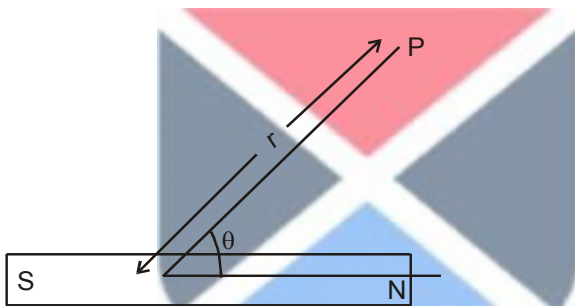

ELECTROMAGNETIC INDUCTION

1. **Magnetic flux** is mathematically defined as $\phi = \int \vec{B} \cdot d\vec{s}$

2. **Faraday's laws of electromagnetic induction**

$$E = - \frac{d\phi}{dt}$$

3. **Lenz's Law** (conservation of energy principle)

According to this law, emf will be induced in such a way that it will oppose the cause which has produced it.

Motional emf

4. **Induced emf due to rotation**

Emf induced in a conducting rod of length l rotating with angular speed ω about its one end, in a uniform perpendicular magnetic field B is $1/2 B \omega$

l^2 .

1. EMF Induced in a rotating disc :

Emf between the centre and the edge of disc of radius r rotating in a

$$\text{magnetic field } B = \frac{B\omega r^2}{2}$$

5. Fixed loop in a varying magnetic field

If magnetic field changes with the rate $\frac{dB}{dt}$, electric field is generated

$$\text{whose average tangential value along a circle is given by } E = \frac{r}{2} \frac{dB}{dt}$$

This electric field is non conservative in nature. The lines of force associated with this electric field are closed curves.

6. Self induction

$$\mathcal{E} = -\frac{\Delta(N\phi)}{\Delta t} = -\frac{\Delta(LI)}{\Delta t} = -\frac{L\Delta I}{\Delta t}$$

$$\text{The instantaneous emf is given as } \mathcal{E} = -\frac{d(N\phi)}{dt} = -\frac{d(LI)}{dt} = -\frac{LdI}{dt}$$

$$\text{Self inductance of solenoid} = \mu_0 n^2 \pi r^2 \ell.$$

6.1 Inductor

It is represent by
electrical equivalence of loop



⇒

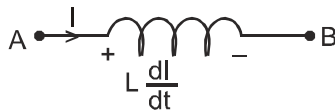
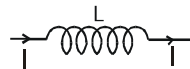
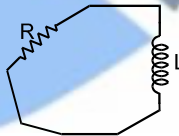

$$V_A - L \frac{dI}{dt} = V_B$$

$$\text{Energy stored in an inductor} = \frac{1}{2} LI^2$$

7. Growth Of Current in Series R-L Circuit

If a circuit consists of a cell, an inductor L and a resistor R and a switch S , connected in series and the switch is closed at $t = 0$, the current in the

$$\text{circuit } I \text{ will increase as } I = \frac{\mathcal{E}}{R} (1 - e^{-\frac{Rt}{L}})$$

The quantity L/R is called time constant of the circuit and is denoted by τ . The variation of current with time is as shown.

1. Final current in the circuit = $\frac{\varepsilon}{R}$, which is independent of L .

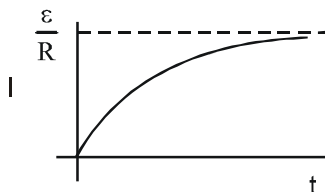

2. After one time constant, current in the circuit = 63% of the final current.
3. More time constant in the circuit implies slower rate of change of current.

8. Decay of current in the circuit containing resistor and inductor:

Let the initial current in a circuit containing inductor and resistor be I_0 .

Current at a time t is given as $I = I_0 e^{-\frac{Rt}{L}}$

Current after one time constant : $I = I_0 e^{-1} = 0.37\%$ of initial current.

9. **Mutual inductance** is induction of EMF in a coil (secondary) due to change in current in another coil (primary). If current in primary coil is I , total flux in secondary is proportional to I , i.e. $N\phi$ (in secondary) $\propto I$.

$$\text{or } N\phi \text{ (in secondary)} = MI$$

The emf generated around the secondary due to the current flowing around the primary is directly proportional to the rate at which that current changes.

10. Equivalent self inductance :

$$L = \frac{V_A - V_B}{dl/dt} \quad \dots(1)$$

1. Series combination :

$$L = L_1 + L_2 \quad (\text{neglecting mutual inductance})$$

$$L = L_1 + L_2 + 2M \quad (\text{if coils are mutually coupled and they have winding in same direction})$$

$$L = L_1 + L_2 - 2M \quad (\text{if coils are mutually coupled and they have winding in opposite direction})$$

2. Parallel Combination :

$$\frac{1}{L} = \frac{1}{L_1} + \frac{1}{L_2} \quad (\text{neglecting mutual inductance})$$

For two coils which are mutually coupled it has been found that $M \leq \sqrt{L_1 L_2}$
 or $M = k \sqrt{L_1 L_2}$ where k is called coupling constant and its value is less than or equal to 1.

$\frac{E_s}{E_p} = \frac{N_s}{N_p} = \frac{I_p}{I_s}$, where denotations have their usual meanings.

$N_s > N_p$
 $\Rightarrow E_s > E_p \rightarrow$
 for step up transformer.

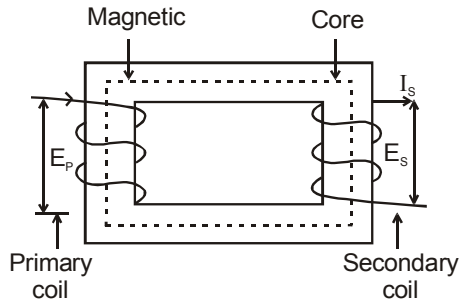

12. LC Oscillations

$$\omega^2 = \frac{1}{LC}$$

GEOMETRICAL OPTICS

1. Reflection of Light

(b) $\angle i = \angle r$

1.3 Characteristics of image due to Reflection by a Plane Mirror:

- (a) Distance of object from mirror = Distance of image from the mirror.
- (b) The line joining a point object and its image is normal to the reflecting surface.
- (c) The size of the image is the same as that of the object.
- (d) For a real object the image is virtual and for a virtual object the image is real

2. Relation between velocity of object and image :

From mirror property : $x_{im} = -x_{om}$, $y_{im} = y_{om}$ and $z_{im} = z_{om}$
 Here x_{im} means 'x' coordinate of image with respect to mirror.
 Similarly others have meaning.

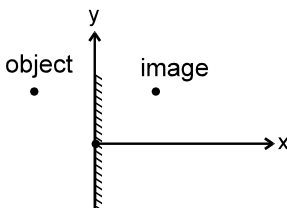

Differentiating w.r.t time , we get

$$V_{(im)x} = -V_{(om)x}; \quad V_{(im)y} = V_{(om)y}; \quad V_{(im)z} = V_{(om)z},$$

3. Spherical Mirror

$$\frac{1}{v} + \frac{1}{u} = \frac{2}{R} = \frac{1}{f} \quad \dots \quad \text{Mirror formula}$$

x co-ordinate of centre of Curvature and focus of Concave mirror are negative and those for Convex mirror are positive.

In case of mirrors since light rays reflect back in - X direction, therefore **-ve sign of v indicates real image and +ve sign of v indicates virtual image**

(b) Lateral magnification (or transverse magnification)

$$m = \frac{h_2}{h_1} \quad m = -\frac{v}{u}$$

(d) On differentiating (a) we get $\frac{dv}{du} = -\frac{v^2}{u^2}$.

(e) On differentiating (a) with respect to time we get

$$\frac{dv}{dt} = -\frac{v^2}{u^2} \frac{du}{dt}, \text{ where } \frac{dv}{dt} \text{ is the velocity of image along Principal}$$

axis and $\frac{du}{dt}$ is the velocity of object along Principal axis. Negative

sign implies that **the image , in case of mirror, always moves in the direction opposite to that of object. This discussion is for velocity with respect to mirror and along the x axis.**

(f) **Newton's Formula:** $XY = f^2$

X and Y are the distances (along the principal axis) of the object and image respectively from the principal focus. This formula can be used when the distances are mentioned or asked from the focus.

(g) Optical power of a mirror (in Diopters) = $\frac{1}{f}$

f = focal length with sign and in meters.

(h) If object lying along the principal axis is not of very small size, the

$$\text{longitudinal magnification} = \frac{v_2 - v_1}{u_2 - u_1} \quad (\text{it will always be inverted})$$

4. Refraction of Light

$$\text{vacuum. } \mu = \frac{\text{speed of light in vacuum}}{\text{speed of light in medium}} = \frac{c}{v}$$

4.1 Laws of Refraction (at any Refracting Surface)

(b) $\frac{\sin i}{\sin r} = \text{Constant}$ for any pair of media and for light of a given wave length. This is known as Snell's Law. More precisely,

$$\frac{\sin i}{\sin r} = \frac{n_2}{n_1} = \frac{v_1}{v_2} = \frac{\lambda_1}{\lambda_2}$$

4.2 Deviation of a Ray Due to Refraction

Deviation (δ) of ray incident at $\angle i$ and refracted at $\angle r$ is given by $\delta = |i - r|$.

5. Principle of Reversibility of Light Rays

A ray travelling along the path of the reflected ray is reflected along the path of the incident ray. A refracted ray reversed to travel back along its path will get refracted along the path of the incident ray. Thus the incident and refracted rays are mutually reversible.

7. Apparent Depth and shift of Submerged Object

At near normal incidence (small angle of incidence i) apparent depth (d') is given by:

$$d' = \frac{d}{n_{\text{relative}}} \Rightarrow n_{\text{relative}} = \frac{n_i (\text{R.I. of medium of incidence})}{n_r (\text{R.I. of medium of refraction})}$$

$$\text{Apparent shift} = d \left(1 - \frac{1}{n_{\text{rel}}} \right)$$

Refraction through a Composite Slab (or Refraction through a number of parallel media, as seen from a medium of R. I. n_0)
Apparent depth (distance of final image from final surface)

$$= \frac{t_1}{n_{1 \text{ rel}}} + \frac{t_2}{n_{2 \text{ rel}}} + \frac{t_3}{n_{3 \text{ rel}}} + \dots + \frac{t_n}{n_{n \text{ rel}}}$$

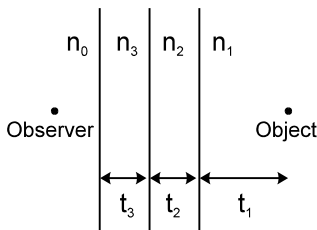

$$\text{Apparent shift} = t_1 \left[1 - \frac{1}{n_{1\text{rel}}} \right] + t_2 \left[1 - \frac{1}{n_{2\text{rel}}} \right] + \dots + \left[1 - \frac{n}{n_{\text{rel}}} \right]$$

8. Critical Angle and Total Internal Reflection (T. I. R.)

$$C = \sin^{-1} \frac{n_r}{n_d}$$

(i) Conditions of T. I. R.

- (a) light is incident on the interface from denser medium.
- (b) Angle of incidence should be greater than the critical angle ($i > c$).

9. Refraction Through Prism

9.1 Characteristics of a prism

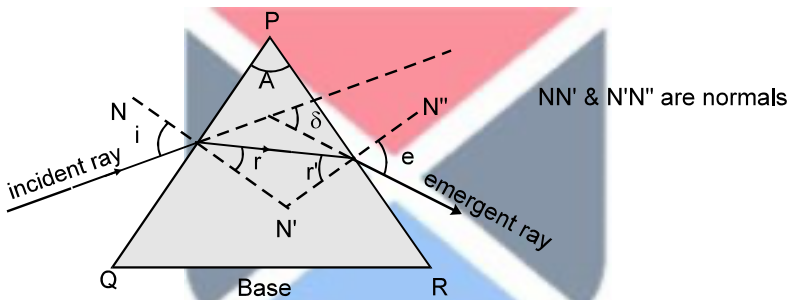

$$\delta = (i + e) - (r_1 + r_2) \text{ and } r_1 + r_2 = A$$

$$\therefore \delta = i + e - A.$$

9.2 Variation of δ versus i

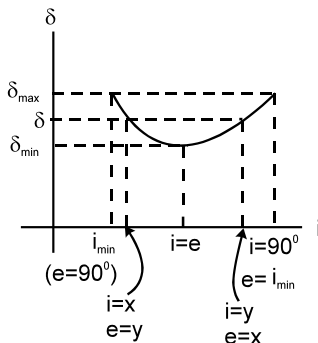

- (1) There is one and only one angle of incidence for which the angle of deviation is minimum.
- (2) When $\delta = \delta_{\min}$, the angle of minimum deviation, then $i = e$ and $r_1 = r_2$, the ray passes symmetrically w.r.t. the refracting surfaces. We can show by simple calculation that $\delta_{\min} = 2i_{\min} - A$ where i_{\min} = angle of incidence for minimum deviation and $r = A/2$.

$$\therefore n_{\text{rel}} = \frac{\sin\left[\frac{A + \delta_{\min}}{2}\right]}{\sin\left[\frac{A}{2}\right]}, \text{ where } n_{\text{rel}} = \frac{n_{\text{prism}}}{n_{\text{surroundings}}}$$

Also $\delta_{\min} = (n - 1)A$ (for small values of $\angle A$)

- (3) For a thin prism ($A \leq 10^\circ$) and for small value of i , all values of

$$\delta = (n_{\text{rel}} - 1)A \quad \text{where } n_{\text{rel}} = \frac{n_{\text{prism}}}{n_{\text{surrounding}}}$$

10. Dispersion Of Light

The angular splitting of a ray of white light into a number of components and spreading in different directions is called Dispersion of Light. This phenomenon is because waves of different wavelength move with same speed in vacuum but with different speeds in a medium.

The refractive index of a medium depends slightly on wavelength also. This variation of refractive index with wavelength is given by Cauchy's formula.

Cauchy's formula $n(\lambda) = a + \frac{b}{\lambda^2}$ where a and b are positive constants

of a medium.

Angle between the rays of the extreme colours in the refracted (dispersed) light is called **angle of dispersion**.

For prism of small ' A ' and with small ' i ' : $\theta = (n_v - n_r)A$

Deviation of beam (also called mean deviation) $\delta = \delta_v = (n_v - 1)A$

Dispersive power (ω) of the medium of the material of prism is given by:

$$\omega = \frac{n_v - n_r}{n_y - 1}$$

For small angled prism ($A \leq 10^\circ$) with light incident at small angle i :

$$\frac{n_v - n_r}{n_y - 1} = \frac{\delta_v - \delta_r}{\delta_y} = \frac{\theta}{\delta_y}$$

$$= \frac{\text{angular dispersion}}{\text{deviation of mean ray (yellow)}}$$

$$[n_y = \frac{n_v + n_r}{2} \text{ if } n_y \text{ is not given in the problem}]$$

$$\omega = \frac{\delta_v - \delta_r}{\delta_y} = \frac{n_v - n_r}{n_y - 1} \text{ [take } n_y = \frac{n_v + n_r}{2} \text{ if value of } n_y \text{ is not given in}$$

the problem]

n_v, n_r and n_y are R. I. of material for violet, red and yellow colours respectively.

11. Combination of Two Prisms

Two or more prisms can be combined in various ways to get different combination of angular dispersion and deviation.

(a) Direct Vision Combination (dispersion without deviation)

The condition for direct vision combination is :

$$\left[\frac{n_v + n_r}{2} - 1 \right] A = \left[\frac{n'_v + n'_r}{2} - 1 \right] A' \Leftrightarrow [n_y - 1] A = [n'_y - 1] A'$$

(b) Achromatic Combination (deviation without dispersion.)

Condition for achromatic combination is: $(n_v - n_r) A = (n'_v - n'_r) A'$

12. Refraction at Spherical Surfaces

For paraxial rays incident on a spherical surface separating two media:

$$\frac{n_2}{v} - \frac{n_1}{u} = \frac{n_2 - n_1}{R}$$

where light moves from the medium of refractive index n_1 to the medium of refractive index n_2 .

Transverse magnification (m) (of dimension perpendicular to principal axis)

due to refraction at spherical surface is given by $m = \frac{v - R}{u - R} = \left(\frac{v/n_2}{u/n_1} \right)$

13. Refraction at Spherical Thin Lens

A thin lens is called convex if it is thicker at the middle and it is called concave if it is thicker at the ends.

For a spherical, thin lens having the same medium on both sides:

$$\frac{1}{v} - \frac{1}{u} = (n_{rel} - 1) \left(\frac{1}{R_1} - \frac{1}{R_2} \right) \quad \text{where } n_{rel} = \frac{n_{lens}}{n_{medium}}$$

$$\frac{1}{f} = (n_{\text{rel}} - 1) \left(\frac{1}{R_1} - \frac{1}{R_2} \right)$$

$$\frac{1}{v} - \frac{1}{u} = \frac{1}{f} \quad \rightarrow \text{Lens Maker's Formula}$$

$$m = \frac{v}{u}$$

Combination Of Lenses:

$$\frac{1}{F} = \frac{1}{f_1} + \frac{1}{f_2} + \frac{1}{f_3} \dots$$

OPTICAL INSTRUMENT

SIMPLE MICROSCOPE

- Magnifying power : $\frac{D}{U_0}$
- when image is formed at infinity $M_{\infty} = \frac{D}{f}$
- When change is formed at near print D. $M_D = 1 + \frac{D}{f}$

COMPOUND MICROSCOPE

Magnifying power

$$M = \frac{V_0 D_0}{U_0 U_e}$$

$$M_{\infty} = \frac{V_0 D}{U_0 f_e}$$

$$M_D = \frac{V_0}{U_0} \left(1 + \frac{D}{f_e} \right)$$

Length of Microscope

$$L = V_0 + U_e$$

$$L = V_0 + f_e$$

$$L_D = V_0 + \frac{D \cdot f_e}{D + f_e}$$

Astronomical Telescope

Magnifying power

$$M = \frac{f_0}{\mu_e}$$

$$M_\infty = \frac{f_0}{f_e}$$

$$M_D = \frac{f_0}{f_e} \left(1 + \frac{f_e}{D} \right)$$

Length of Microscope

$$L = f + u_e.$$

$$L = f_0 + f_e$$

$$L_D = f_0 + \frac{Df_e}{D + f_e}$$

Terrestrial Telescope

Magnifying power

$$M = \frac{f_0}{U_e}$$

$$M_\infty = \frac{f_0}{f_e}$$

$$M_D = \frac{f_0}{f_e} \left(1 + \frac{f_e}{D} \right)$$

Length of Microscope

$$L = f_0 + 4f + U_e.$$

$$L = f_0 + 4f + f_e.$$

$$L_D = f_0 + 4f + \frac{Df_e}{D + f_e}$$

Galilean Telescope

Magnifying power

$$M = \frac{f_0}{U_e}$$

$$M_\infty = \frac{f_0}{f_e}$$

$$M_D = \frac{f_0}{f_e} \left(1 - \frac{f_e}{d} \right)$$

Length of Microscope

$$L = f_0 - U_e.$$

$$L = f_0 - f_e.$$

$$L_D = f_0 - \frac{f_e D}{D - f_e}$$

Resolving Power

Microscope $R = \frac{1}{\Delta d} = \frac{2\mu \sin \theta}{\lambda}$

Telescope. $R = \frac{1}{\Delta \theta} = \frac{a}{1.22\lambda}$

MODERN PHYSICS

- * Work function is minimum for cesium (1.9 eV)
- * work function $W = h\nu_0 = \frac{hc}{\lambda_0}$
- * Photoelectric current is directly proportional to intensity of incident radiation. (ν – constant)
- * Photoelectrons ejected from metal have kinetic energies ranging from 0 to KE_{\max}
Here $KE_{\max} = eV_s$ V_s - stopping potential
- * Stopping potential is independent of intensity of light used (ν -constant)
- * Intensity in the terms of electric field is

$$I = \frac{1}{2} \epsilon_0 E^2 \cdot c$$

- * Momentum of one photon is $\frac{h}{\lambda}$.
- * Einstein equation for photoelectric effect is

$$h\nu = w_0 + k_{\max} \Rightarrow \frac{hc}{\lambda} = \frac{hc}{\lambda_0} + eV_s$$

- * Energy $\Delta E = \frac{12400}{\lambda(A^{\circ})} \text{ eV}$
- * Force due to radiation (Photon) (no transmission)
When light is incident perpendicularly

(a) $a = 1$ $r = 0$

$$F = \frac{IA}{c}, \quad \text{Pressure} = \frac{I}{c}$$

(b) $r = 1,$ $a = 0$

$$F = \frac{2IA}{c}, \quad P = \frac{2I}{c}$$

(c) when $0 < r < 1$ and $a + r = 1$

$$F = \frac{IA}{c} (1 + r), \quad P = \frac{I}{c} (1 + r)$$

When light is incident at an angle θ with vertical.

(a) $a = 1, r = 0$

$$F = \frac{IA \cos \theta}{c}, \quad P = \frac{F \cos \theta}{A} = \frac{I}{c} \cos^2 \theta$$

(b) $r = 1, a = 0$

$$F = \frac{2IA \cos^2 \theta}{c}, \quad P = \frac{2I \cos^2 \theta}{c}$$

(c) $0 < r < 1, \quad a + r = 1$

$$P = \frac{I \cos^2 \theta}{c} (1 + r)$$

* De Broglie wavelength

$$\lambda = \frac{h}{mv} = \frac{h}{P} = \frac{h}{\sqrt{2mKE}}$$

* Radius and speed of electron in hydrogen like atoms.

$$r_n = \frac{n^2}{Z} a_0 \quad a_0 = 0.529 \text{ \AA}$$

$$v_n = \frac{Z}{n} v_0 \quad v_0 = 2.19 \times 10^6 \text{ m/s}$$

* Energy in nth orbit

$$E_n = E_1 \cdot \frac{Z^2}{n^2} \quad E_1 = -13.6 \text{ eV}$$

* Wavelength corresponding to spectral lines

$$\frac{1}{\lambda} = R \left[\frac{1}{n_1^2} - \frac{1}{n_2^2} \right]$$

for Lyman series $n_1 = 1 \quad n_2 = 2, 3, 4, \dots$

Balmer $n_1 = 2 \quad n_2 = 3, 4, 5, \dots$

Paschen $n_1 = 3 \quad n_2 = 4, 5, 6, \dots$

* The Lyman series is in the ultraviolet and Paschen, Brackett and Pfund series are in the infrared region.

* Total number of possible transitions, is $\frac{n(n-1)}{2}$, (from nth state)

* If effect of nucleus motion is considered,

$$r_n = (0.529 \text{ \AA}) \frac{n^2}{Z} \cdot \frac{m}{\mu}$$

$$E_n = (-13.6 \text{ eV}) \frac{Z^2}{n^2} \cdot \frac{\mu}{m}$$

Here μ - reduced mass

$$\mu = \frac{Mm}{(M+m)}, \quad M - \text{mass of nucleus}$$

* Minimum wavelength for x-rays

$$\lambda_{\min} = \frac{hc}{eV_0} = \frac{12400}{V_0(\text{volt})} \text{ \AA}$$

* Moseley's Law

$$\sqrt{\nu} = a(z - b)$$

a and b are positive constants for one type of x-rays (independent of Z)

* Average radius of nucleus may be written as

$$R = R_0 A^{1/3}, \quad R_0 = 1.1 \times 10^{-15} \text{ M}$$

A - mass number

* Binding energy of nucleus of mass M, is given by $B = (ZM_p + NM_N - M)c^2$

* Alpha - decay process

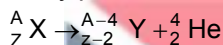

Q-value is

$$Q = [m({}^A_Z X) - m({}^{A-4}_{Z-2} Y) - m({}^4_2 \text{He})]c^2$$

* Beta- minus decay

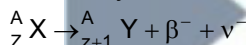

$$Q\text{-value} = [m({}^A_Z X) - m({}^A_{Z+1} Y)]c^2$$

* Beta plus-decay

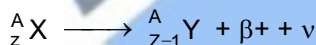

$$Q\text{-value} = [m({}^A_Z X) - m({}^A_{Z-1} Y) - 2me]c^2$$

* Electron capture : when atomic electron is captured, X-rays are emitted.

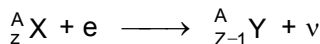

$$Q\text{-value} = [m({}^A_Z X) - m({}^A_{Z-1} Y)]c^2$$

* In radioactive decay, number of nuclei at instant t is given by $N = N_0 e^{-\lambda t}$, λ -decay constant.

* Activity of sample : $A = A_0 e^{-\lambda t}$

* Activity per unit mass is called specific activity.

$$* \text{ Half life : } T_{1/2} = \frac{0.693}{\lambda}$$

$$* \text{ Average life : } T_{av} = \frac{T_{1/2}}{0.693}$$

- * A radioactive nucleus can decay by two different processes having half lives t_1 and t_2 respectively. Effective half-life of nucleus is given by
- $$\frac{1}{t} = \frac{1}{t_1} + \frac{1}{t_2}.$$

WAVE OPTICS

Interference of waves of intensity I_1 and I_2 :

resultant intensity, $I = I_1 + I_2 + 2\sqrt{I_1 I_2} \cos(\Delta\phi)$ where, $\Delta\phi$ = phase difference.

For Constructive Interference : $I_{\max} = (\sqrt{I_1} + \sqrt{I_2})^2$

For Destructive interference : $I_{\min} = (\sqrt{I_1} - \sqrt{I_2})^2$

If sources are incoherent

$I = I_1 + I_2$, at each point.

YDSE :

Path difference, $\Delta p = S_2P - S_1P = d \sin \theta$

if $d \ll D$ $= \frac{dy}{D}$

if $y \ll D$

for maxima,

$\Delta p = n\lambda$

for minima

$\Rightarrow y = n\beta$ $n = 0, \pm 1, \pm 2 \dots\dots$

$$\Delta p = \Delta p = \begin{cases} (2n-1)\frac{\lambda}{2} & n = 1, 2, 3, \dots\dots\dots \\ (2n+1)\frac{\lambda}{2} & n = -1, -2, -3, \dots\dots\dots \end{cases}$$

$$\Rightarrow y = \begin{cases} (2n-1)\frac{\beta}{2} & n = 1, 2, 3, \dots\dots\dots \\ (2n+1)\frac{\beta}{2} & n = -1, -2, -3, \dots\dots\dots \end{cases}$$

where, fringe width $\beta = \frac{\lambda D}{d}$

Here, λ = wavelength in medium.

Highest order maxima : $n_{\max} = \left[\frac{d}{\lambda} \right]$

total number of maxima = $2n_{\max} + 1$

Highest order minima : $n_{\max} = \left[\frac{d}{\lambda} + \frac{1}{2} \right]$

total number of minima = $2n_{\max}$

Intensity on screen : $I = I_1 + I_2 + 2\sqrt{I_1 I_2} \cos(\Delta\phi)$ where, $\Delta\phi = \frac{2\pi}{\lambda} \Delta p$

If $I_1 = I_2$, $I = 4I_1 \cos^2\left(\frac{\Delta\phi}{2}\right)$

YDSE with two wavelengths λ_1 & λ_2 :

The nearest point to central maxima where the bright fringes coincide:

$$y = n_1\beta_1 = n_2\beta_2 = \text{Lcm of } \beta_1 \text{ and } \beta_2$$

The nearest point to central maxima where the two dark fringes coincide,

$$y = \left(n_1 - \frac{1}{2}\right)\beta_1 = \left(n_2 - \frac{1}{2}\right)\beta_2$$

Optical path difference

$$\Delta p_{\text{opt}} = \mu \Delta p$$

$$\Delta\phi = \frac{2\pi}{\lambda} \Delta p = \frac{2\pi}{\lambda_{\text{vacuum}}} \Delta p_{\text{opt.}}$$

$$\Delta = (\mu - 1) t. \quad \frac{D}{d} = (\mu - 1) t \frac{B}{\lambda}.$$

YDSE WITH OBLIQUE INCIDENCE

In YDSE, ray is incident on the slit at an inclination of θ_0 to the axis of symmetry of the experimental set-up

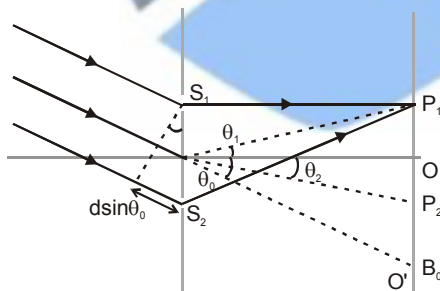

We obtain central maxima at a point where, $\Delta p = 0$.

$$\text{or } \theta_2 = \theta_0.$$

This corresponds to the point O' in the diagram.

Hence we have path difference.

$$\Delta p = \begin{cases} d(\sin \theta_0 + \sin \theta) & \text{for points above } O \\ d(\sin \theta_0 - \sin \theta) & \text{for points between } O \text{ \& } O' \\ d(\sin \theta - \sin \theta_0) & \text{for points below } O' \end{cases} \quad \dots (8.1)$$

THIN-FILM INTERFERENCE

for interference in reflected light $2\mu d$

$$= \begin{cases} n\lambda & \text{for destructive interference} \\ \left(n + \frac{1}{2}\right)\lambda & \text{for constructive interference} \end{cases}$$

for interference in transmitted light $2\mu d$

$$= \begin{cases} n\lambda & \text{for constructive interference} \\ \left(n + \frac{1}{2}\right)\lambda & \text{for destructive interference} \end{cases}$$

Polarisation

- $\mu = \tan \theta_p$ (Brewster's angle)
 $\theta_p + \theta_r = 90^\circ$ (reflected and refracted rays are mutually perpendicular.)

- **Law of Malus.**

$$I = I_0 \cos^2 \theta$$

$$I = KA^2 \cos^2 \theta$$

- **Optical activity**

$$[\alpha]_t^{\lambda, c} = \frac{\theta}{L \times C}$$

θ = rotation in length L at concentration C.

Diffraction

- $a \sin \theta = (2m + 1) \frac{\lambda}{2}$ for maxima. where $m = 1, 2, 3, \dots$

- $\sin \theta = \frac{m\lambda}{a}$, $m = \pm 1, \pm 2, \pm 3, \dots$ for minima.

- Linear width of central maxima = $\frac{2d\lambda}{a}$

- Angular width of central maxima = $\frac{2\lambda}{a}$

- $I = I_0 \left[\frac{\sin \beta/2}{\beta/2} \right]^2$ where $\beta = \frac{\pi a \sin \theta}{\lambda}$

- Resolving power .

$$R = \frac{\lambda}{\lambda_2 - \lambda_1} = \frac{\lambda}{\Delta\lambda}$$

where , $\lambda = \frac{\lambda_1 + \lambda_2}{2}$, $\Delta\lambda = \lambda_2 - \lambda_1$

GRAVITATION

GRAVITATION : Universal Law of Gravitation

$$F \propto \frac{m_1 m_2}{r^2} \text{ or } F = G \frac{m_1 m_2}{r^2}$$

where $G = 6.67 \times 10^{-11} \text{ Nm}^2 \text{ kg}^{-2}$ is the universal gravitational constant.

Newton's Law of Gravitation in vector form :

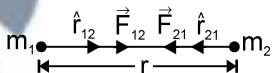
$$\vec{F}_{12} = \frac{Gm_1 m_2}{r^2} \hat{r}_{12} \quad \& \quad \vec{F}_{21} = \frac{Gm_1 m_2}{r^2} \hat{r}_{21}$$

Now $\hat{r}_{12} = -\hat{r}_{21}$, Thus $\vec{F}_{21} = \frac{-Gm_1 m_2}{r^2} \hat{r}_{12}$.

Comparing above, we get $\vec{F}_{12} = -\vec{F}_{21}$

Gravitational Field

$$E = \frac{F}{m} = \frac{GM}{r^2}$$

Gravitational potential : gravitational potential,

$$V = -\frac{GM}{r} \quad E = -\frac{dV}{dr}$$

1. **Ring.** $V = \frac{-GM}{x \text{ or } (a^2 + r^2)^{1/2}}$ & $E = \frac{-GMr}{(a^2 + r^2)^{3/2}} \hat{r}$

or $E = -\frac{GM \cos \theta}{x^2}$

Gravitational field is maximum at a distance,

$$r = \pm a/\sqrt{2} \text{ and it is } -2GM/3\sqrt{3}a^2$$

2. Thin Circular Disc.

$$V = \frac{-2GM}{a^2} \left[\left[a^2 + r^2 \right]^{\frac{1}{2}} - r \right] \quad \& \quad E = -\frac{2GM}{a^2} \left[1 - \frac{r}{\left[r^2 + a^2 \right]^{\frac{1}{2}}} \right] = -\frac{2GM}{a^2} [1 - \cos \theta]$$

3. Non conducting solid sphere

(a) Point P inside the sphere. $r \leq a$, then

$$V = -\frac{GM}{2a^3}(3a^2 - r^2) \quad \& \quad E = -\frac{GMr}{a^3}, \text{ and at the centre } V = -\frac{3GM}{2a} \text{ and } E = 0$$

(b) Point P outside the sphere .

$$r \geq a, \text{ then } V = -\frac{GM}{r} \quad \& \quad E = -\frac{GM}{r^2}$$

4. Uniform Thin Spherical Shell / Conducting solid sphere

(a) Point P Inside the shell.

$$r \leq a, \text{ then } V = \frac{-GM}{a} \quad \& \quad E = 0$$

(b) Point P outside shell.

$$r \geq a, \text{ then } V = \frac{-GM}{r} \quad \& \quad E = -\frac{GM}{r^2}$$

VARIATION OF ACCELERATION DUE TO GRAVITY :

1. Effect of Altitude

$$g_h = \frac{GM_e}{(R_e + h)^2} = g \left(1 + \frac{h}{R_e} \right)^{-2} \simeq g \left(1 - \frac{2h}{R_e} \right) \text{ when } h \ll R_e.$$

2. Effect of depth $g_d = g \left(1 - \frac{d}{R_e} \right)$

3. Effect of the surface of Earth

The equatorial radius is about 21 km longer than its polar radius.

We know, $g = \frac{GM_e}{R_e^2}$ Hence $g_{\text{pole}} > g_{\text{equator}}$.

SATELLITE VELOCITY (OR ORBITAL VELOCITY)

$$v_0 = \left[\frac{GM_e}{(R_e + h)} \right]^{\frac{1}{2}} = \left[\frac{gR_e^2}{(R_e + h)} \right]^{\frac{1}{2}}$$

When $h \ll R_e$ then $v_0 = \sqrt{gR_e}$

$$\therefore v_0 = \sqrt{9.8 \times 6.4 \times 10^6} = 7.92 \times 10^3 \text{ ms}^{-1} = 7.92 \text{ km s}^{-1}$$

Time period of Satellite

$$T = \frac{2\pi(R_e + h)}{\left[\frac{gR_e^2}{(R_e + h)}\right]^{\frac{1}{2}}} = \frac{2\pi}{R_e} \left[\frac{(R_e + h)^3}{g}\right]^{\frac{1}{2}}$$

Energy of a Satellite

$$U = \frac{-GM_em}{r} \quad \text{K.E.} = \frac{GM_em}{2r} ; \text{ then total energy } \rightarrow E = -\frac{GM_em}{2R_e}$$

Kepler's Laws

Law of area :

The line joining the sun and a planet sweeps out equal areas in equal intervals of time.

$$\text{Areal velocity} = \frac{\text{area swept}}{\text{time}} = \frac{\frac{1}{2}r(rd\theta)}{dt} = \frac{1}{2} r^2 \frac{d\theta}{dt} = \text{constant.}$$

$$\text{Hence } \frac{1}{2} r^2 \omega = \text{constant.} \quad \text{Law of periods : } \frac{T^2}{R^3} = \text{constant}$$

FLUID MECHANICS & PROPERTIES OF MATTER

FLUIDS, SURFACE TENSION, VISCOSITY & ELASTICITY :

1. Hydraulic press. $p = \frac{f}{a} = \frac{F}{A}$ or $F = \frac{A}{a} \times f$.

Hydrostatic Paradox $P_A = P_B = P_C$

(i) Liquid placed in elevator : When elevator accelerates upward with acceleration a_0 then pressure in the fluid, at depth 'h' may be given by,

$$p = \rho h [g + a_0]$$

and force of buoyancy, $B = m (g + a_0)$

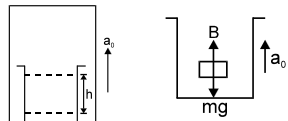

(ii) Free surface of liquid in horizontal acceleration :

$$\tan \theta = \frac{a_0}{g}$$

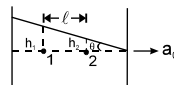

$p_1 - p_2 = \rho \ell a_0$ where p_1 and p_2 are pressures at points 1 & 2.

Then $h_1 - h_2 = \frac{\ell a_0}{g}$

(iii) Free surface of liquid in case of rotating cylinder.

$$h = \frac{v^2}{2g} = \frac{\omega^2 r^2}{2g}$$

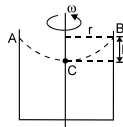

Equation of Continuity

$$a_1 v_1 = a_2 v_2$$

In general $av = \text{constant}$.

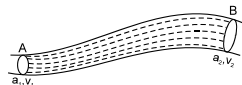

Bernoulli's Theorem

i.e. $\frac{P}{\rho} + \frac{1}{2} v^2 + gh = \text{constant}$.

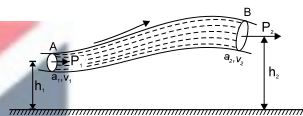

(vi) Torricelli's theorem – (speed of efflux) $v = \sqrt{1 - \frac{A_2^2}{A_1^2} \cdot 2gh}$, $A_2 = \text{area of hole}$
 $A_1 = \text{area of vessel}$.

ELASTICITY & VISCOSITY : $\text{stress} = \frac{\text{restoring force}}{\text{area of the body}} = \frac{F}{A}$

Strain, $\epsilon = \frac{\text{change in configuration}}{\text{original configuration}}$

(i) Longitudinal strain = $\frac{\Delta L}{L}$

(ii) $\epsilon_v = \text{volume strain} = \frac{\Delta V}{V}$

(iii) Shear Strain : $\tan \phi$ or $\phi = \frac{x}{\ell}$

1. Young's modulus of elasticity $Y = \frac{F/A}{\Delta L/L} = \frac{FL}{A\Delta L}$

Potential Energy per unit volume = $\frac{1}{2} (\text{stress} \times \text{strain}) = \frac{1}{2} (Y \times \text{strain}^2)$

Inter-Atomic Force-Constant $k = Yr_0$.

Newton's Law of viscosity, $F \propto A \frac{dv}{dx}$ or $F = -\eta A \frac{dv}{dx}$

Stoke's Law $F = 6 \pi \eta r v$. Terminal velocity = $\frac{2}{9} \frac{r^2(\rho - \sigma)g}{\eta}$

SURFACE TENSION

Surface tension (T) = $\frac{\text{Total force on either of the imaginary line (F)}}{\text{Length of the line (l)}}$;

$$T = S = \frac{\Delta W}{A}$$

Thus, surface tension is numerically equal to surface energy or work done per unit increase surface area.

Inside a bubble : $(p - p_a) = \frac{4T}{r} = p_{\text{excess}}$;

Inside the drop : $(p - p_a) = \frac{2T}{r} = p_{\text{excess}}$

Inside air bubble in a liquid : $(p - p_a) = \frac{2T}{r} = p_{\text{excess}}$

Capillary Rise $h = \frac{2T \cos \theta}{r \rho g}$

SOUND WAVES

- (i) Longitudinal displacement of sound wave
 $\xi = A \sin(\omega t - kx)$
- (ii) Pressure excess during travelling sound wave

$$P_{\text{ex}} = -B \frac{\partial \xi}{\partial x} \quad (\text{it is true for travelling wave as well as standing waves})$$

Amplitude of pressure excess = BAK

- (iii) Speed of sound $C = \sqrt{\frac{E}{\rho}}$

Where E = Elastic modulus for the medium
 ρ = density of medium

– for solid $C = \sqrt{\frac{Y}{\rho}}$

where Y = young's modulus for the solid

– for liquid $C = \sqrt{\frac{B}{\rho}}$

where B = Bulk modulus for the liquid

– for gases $C = \sqrt{\frac{B}{\rho}} = \sqrt{\frac{\gamma P}{\rho}} = \sqrt{\frac{\gamma RT}{M_0}}$

where M_0 is molecular wt. of the gas in (kg/mole)

Intensity of sound wave :

$$\langle I \rangle = 2\pi^2 f^2 A^2 \rho v = \frac{P_m^2}{2\rho v} \quad \langle I \rangle \propto P_m^2$$

(iv) Loudness of sound : $L = 10 \log_{10} \left(\frac{I}{I_0} \right) \text{ dB}$

where $I_0 = 10^{-12} \text{ W/m}^2$ (This the minimum intensity human ears can listen)

Intensity at a distance r from a point source = $I = \frac{P}{4\pi r^2}$

Interference of Sound Wave

if $P_1 = p_{m1} \sin(\omega t - kx_1 + \theta_1)$

$P_2 = p_{m2} \sin(\omega t - kx_2 + \theta_2)$

resultant excess pressure at point O is

$p = P_1 + P_2$

$p = p_0 \sin(\omega t - kx + \theta)$

$p_0 = \sqrt{p_{m1}^2 + p_{m2}^2 + 2p_{m1}p_{m2} \cos \phi}$

where $\phi = [k(x_2 - x_1) + (\theta_1 - \theta_2)]$

and $I = I_1 + I_2 + 2\sqrt{I_1 I_2}$

(i) For constructive interference

$\phi = 2n\pi$ and $\Rightarrow p_0 = p_{m1} + p_{m2}$ (constructive interference)

(ii) For destructive interference

$\phi = (2n+1)\pi$ and $\Rightarrow p_0 = |p_{m1} - p_{m2}|$ (destructive interference)

If ϕ is due to path difference only then $\phi = \frac{2\pi}{\lambda} \Delta x$.

Condition for constructive interference : $\Delta x = n\lambda$

Condition for destructive interference : $\Delta x = (2n+1) \frac{\lambda}{2}$.

- (a) If $p_{m1} = p_{m2}$ and $\theta = \pi, 3\pi, \dots$
resultant $p = 0$ i.e. no sound
- (b) If $p_{m1} = p_{m2}$ and $\phi = 0, 2\pi, 4\pi, \dots$
 $p_0 = 2p_m$ & $I_0 = 4I_1$
 $p_0 = 2p_{m1}$

Close organ pipe :

$$f = \frac{v}{4\ell}, \frac{3v}{4\ell}, \frac{5v}{4\ell}, \dots, \frac{(2n+1)v}{4\ell} \quad n = \text{overtone}$$

Open organ pipe :

$$f = \frac{v}{2\ell}, \frac{2v}{2\ell}, \frac{3v}{2\ell}, \dots, \frac{nV}{2\ell}$$

Beats : Beatsfrequency = $|f_1 - f_2|$.

Doppler's Effect

The observed frequency, $f' = f \left(\frac{v - v_0}{v - v_s} \right)$

and Apparent wavelength $\lambda' = \lambda \left(\frac{v - v_s}{v} \right)$

ELECTRO MAGNETIC WAVES

Maxwell's equations

$$\oint \mathbf{E} \cdot d\mathbf{A} = Q / \epsilon_0 \quad (\text{Gauss's Law for electricity})$$

$$\oint \mathbf{B} \cdot d\mathbf{A} = 0 \quad (\text{Gauss's Law for magnetism})$$

$$\oint \mathbf{E} \cdot d\mathbf{l} = \frac{-d\Phi_B}{dt} \quad (\text{Faraday's Law})$$

$$\oint \mathbf{B} \cdot d\mathbf{l} = \mu_0 i_c + \mu_0 \epsilon_0 \frac{d\Phi_E}{dt} \quad (\text{Ampere-Maxwell Law})$$

Oscillating electric and magnetic fields

$$E = E_x(t) = E_0 \sin(kz - \omega t)$$

$$= E_0 \sin \left[2\pi \left(\frac{z}{\lambda} - vt \right) \right] = E_0 \sin \left[2\pi \left(\frac{z}{\lambda} - \frac{t}{T} \right) \right]$$

$$E_0/B_0 = c$$

$$c = 1/\sqrt{\mu_0 \epsilon_0} \quad c \text{ is speed of light in vaccum}$$

$$v = 1/\sqrt{\mu \epsilon} \quad v \text{ is speed of light in medium}$$

$p = \frac{U}{c}$ energy transferred to a surface in time t is U , the magnitude of the total momentum delivered to this surface (for complete absorption) is p

Electromagnetic spectrum

Type	Wavelength range	Production	Detection
Radio	> 0.1m	Rapid acceleration and decelerations of electrons in aerials	Receiver's aerials
Microwave	0.1m to 1mm	Klystron valve or magnetron valve	Point contact diodes
Infra-red	1mm to 700nm	Vibration of atoms and molecules	Thermopiles Bolometer, Infrared photographic film
Light	700nm to 400nm	Electrons in atoms emit light when they move from one energy level to a lower energy	The eye, photocells, Photographic film
Ultraviolet	400nm to 1nm	Inner shell electrons in atoms moving from one energy level to a lower level	photocells photographic film
X-rays	1nm to 10^{-3} nm	X-ray tubes or inner shell electrons	Photographic film, Geiger tubes, ionisation chamber
Gamma rays	< 10^{-3} nm	Radioactive decay of the nucleus	do

ERROR AND MEASUREMENT

1. Least Count

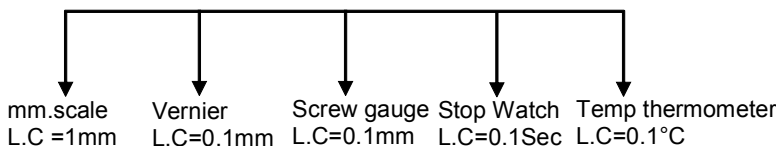

2. Significant Figures

- Non-zero digits are significant
- Zeros occurring between two non-zeros digits are significant.
- Change of units cannot change S.F.
- In the number less than one, all zeros after decimal point and to the left of first non-zero digit are insignificant
- The terminal or trailing zeros in a number without a decimal point are not significant.

3. Permissible Error

- Max permissible error in a measured quantity = least count of the measuring instrument and if nothing is given about least count then Max permissible error = place value of the last number
- $f(x,y) = x + y$ then $(\Delta f)_{\max} = \max \text{ of } (\pm \Delta X \pm \Delta Y)$

- $f(x,y,z) = (\text{constant}) x^a y^b z^c$ then $\left(\frac{\Delta f}{f}\right)_{\max}$
 $= \max \text{ of } \left(\pm a \frac{\Delta x}{x} \pm b \frac{\Delta y}{y} \pm c \frac{\Delta z}{z} \right)$

4. Errors in averaging

- Absolute Error $\Delta a_n = |a_{\text{mean}} - a_n|$
- Mean Absolute Error $\Delta a_{\text{mean}} = \left(\sum_{i=1}^n |\Delta a_i| \right) / n$
- Relative error = $\frac{\Delta a_{\text{mean}}}{a_{\text{mean}}}$
- Percentage error = $\frac{\Delta a_{\text{mean}}}{a_{\text{mean}}} \times 100$

5. Experiments

- Reading of screw gauge
Thickness of object = Reading of screw gauge

$$= \left(\begin{array}{c} \text{main} \\ \text{scale} \\ \text{reading} \end{array} \right) + \left(\begin{array}{c} \text{circular} \\ \text{scale} \\ \text{reading} \end{array} \right) \left(\begin{array}{c} \text{Least} \\ \text{count} \end{array} \right)$$

$$\text{least count of screw gauge} = \frac{\text{pitch}}{\text{No. of circular scale division}}$$

- Vernier callipers
Thickness of object = Reading of vernier calliper

$$= \left(\begin{array}{c} \text{main} \\ \text{scale} \\ \text{reading} \end{array} \right) + \left(\begin{array}{c} \text{vernier} \\ \text{scale} \\ \text{reading} \end{array} \right) \left(\begin{array}{c} \text{Least} \\ \text{count} \end{array} \right)$$

$$\text{Least count of vernier calliper} = 1 \text{ MSD} - 1 \text{ VSD}$$

PRINCIPLE OF COMMUNICATION

Transmission from tower of height h

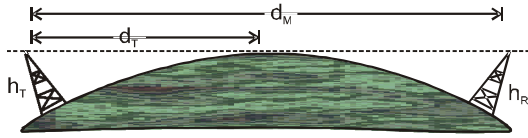

- the distance to the horizon $d_T = \sqrt{2Rh_T}$

- $d_M = \sqrt{2Rh_T} + \sqrt{2Rh_R}$

Amplitude Modulation

- The modulated signal $c_m(t)$ can be written as

$$c_m(t) = A_c \sin \omega_c t + \frac{\mu A_c}{2} \cos (\omega_c - \omega_m) t - \frac{\mu A_c}{2} \cos (\omega_c + \omega_m)$$

- Modulation index $m_a = \frac{\text{Change in amplitude of carrier wave}}{\text{Amplitude of original carrier wave}} = \frac{kA_m}{A_c}$

where $k = A$ factor which determines the maximum change in the amplitude for a given amplitude E_m of the modulating. If $k = 1$ then

$$m_a = \frac{A_m}{A_c} = \frac{A_{\max} - A_{\min}}{A_{\max} + A_{\min}}$$

- If a carrier wave is modulated by several sine waves the total modulated

index m_t is given by $m_t = \sqrt{m_1^2 + m_2^2 + m_3^2 + \dots}$

- Side band frequencies

$(f_c + f_m)$ = Upper side band (USB) frequency

$(f_c - f_m)$ = Lower side band (LBS) frequency

- Band width $= (f_c + f_m) - (f_c - f_m) = 2f_m$

- Power in AM waves : $P = \frac{V_{\text{rms}}^2}{R}$

(i) carrier power $P_c = \frac{\left(\frac{A_c}{\sqrt{2}}\right)^2}{R} = \frac{A_c^2}{2R}$

$$(ii) \text{ Total power of side bands } P_{sb} = \frac{\left(\frac{m_a A_c}{2\sqrt{2}}\right)^2}{R} = \frac{\left(\frac{m_a A_c}{2\sqrt{2}}\right)^2}{2R} = \frac{m_a^2 A_c^2}{4R}$$

$$(iii) \text{ Total power of AM wave } P_{Total} = P_c + P_{ab} = \frac{A_c^2}{2R} \left(1 + \frac{m_a^2}{2}\right)$$

$$(iv) \frac{P_t}{P_c} = \left(1 + \frac{m_a^2}{2}\right) \text{ and } \frac{P_{sb}}{P_t} = \frac{m_a^2/2}{\left(1 + \frac{m_a^2}{2}\right)}$$

(v) Maximum power in the AM (without distortion) will occur when $m_a = 1$ i.e., $P_t = 1.5 P_c = 3 P_{ab}$

(vi) If $I_c =$ Unmodulated current and $I_t =$ total or modulated current

$$\Rightarrow \frac{P_t}{P_c} = \frac{I_t^2}{I_c^2} \Rightarrow \frac{I_t}{I_c} = \sqrt{\left(1 + \frac{m_a^2}{2}\right)}$$

Frequency Modulation

- Frequency deviation $\delta = (f_{max} - f_c) = f_c - f_{min} = k_f \cdot \frac{E_m}{2\pi}$

- Carrier swing (CS) = $CS = 2 \times \Delta f$

- Frequency modulation index (m_f)

$$m_f = \frac{\delta}{f_m} = \frac{f_{max} - f_c}{f_m} = \frac{f_c - f_{min}}{f_m} = \frac{k_f E_m}{f_m}$$

- Frequency spectrum = FM side band modulated signal consist of infinite number of side bands whose frequencies are $(f_c \pm f_m)$, $(f_c \pm 2f_m)$, $(f_c \pm 3f_m)$,.....

- Deviation ratio = $\frac{(\Delta f)_{max}}{(f_m)_{max}}$

- Percent modulation, $m = \frac{(\Delta f)_{actual}}{(\Delta f)_{max}}$

SEMICONDUCTOR

Conductivity and resistivity

	$P (\pi - m)$	$\rho (\pi^{-1}m^{-1})$
Metals	$10^{-2} - 10^{-6}$	$10^2 - 10^8$
semiconductors	$10^{-5} - 10^{-6}$	$10^5 - 10^6$
Insulators	$10^{11} - 10^{19}$	$10^{-11} - 10^{-19}$

Charge concentration and current

- $[\eta_n = \eta_e]$ In case of intrinsic semiconductors
- P type $\eta_n \gg \eta_e$
- $i = i_e + i_h$
- $\eta_e \eta_n = \eta_i^2$
- Number of electrons reaching from valence bond to conduction bond.
 $\eta = A T^{3/2} e^{-E_g/2kT}$ (A is positive constant)
- $\sigma = e (\eta_e m_e + \eta_n \mu_n)$
 for p type $\eta_n = Na \gg \eta_e$
 for n-type $\eta_e = Na \gg \eta_n$
- Dynamic Resistance of P-N junction in forward biasing = $\frac{\Delta V}{\Delta I}$

Transistor

• CB amplifier

(i) ac current gain $\alpha_c = \frac{\text{Small change in collector current } (\Delta i_c)}{\text{Small change in emitter current } (\Delta i_e)}$

(ii) dc current gain $\alpha_{dc} = \frac{\text{Collector current } (i_c)}{\text{Emitter current } (i_e)}$ value of α_{dc} lies between 0.95 to 0.99

(iii) Voltage gain $A_v = \frac{\text{Change in output voltage } (\Delta V_o)}{\text{Change in input voltage } (\Delta V_f)}$

$\Rightarrow A_v = a_{ac} \times \text{Resistance gain}$

(iv) Power gain = $\frac{\text{Change in output power } (\Delta P_o)}{\text{Change in input power } (\Delta P_i)}$

$\Rightarrow \text{Power gain} = a_{ac}^2 \times \text{Resistance gain}$

(v) Phase difference (between output and input) : same phase

(vi) Application : For High frequency

CE Amplifier

(i) ac current gain $\beta_{ac} = \left(\frac{\Delta i_c}{\Delta i_b} \right) V_{CE} = \text{constant}$

(ii) dc current gain $\beta_{dc} = \frac{i_c}{i_b}$

(iii) Voltage gain : $A_V = \frac{\Delta V_0}{\Delta V_i} = \beta_{ac} \times \text{Resistance gain}$

(iv) Power gain = $\frac{\Delta P_0}{\Delta P_i} = \beta^2_{ac} \times \text{Resistance}$

(v) Transconductance (g_m) : The ratio of the change in collector current to the change in emitter base voltage is called trans

conductance i.e. $g_m = \frac{\Delta i_c}{\Delta V_{EB}}$. Also $g_m = \frac{A_V}{R_L}$ $R_L = \text{Load resistance.}$

• **Relation between α and β :** $\beta = \frac{\alpha}{1-\alpha}$ or $\alpha = \frac{\beta}{1+\beta}$

ductance (g_m) is the ratio of the change in collector current to the change in emitter base voltage is called transconductance. $R_L = \text{Load resistance.}$

ROUGH WORK

