

TEST REPORT

Report No.: E1718.01-109-44

Rendered to:

VISION INDUSTRIES GROUP, INC.
South Plain field, New Jersey

PRODUCT TYPE: Window Opening Control Device **SERIES/**
MODEL: 1700 Series Pre-Installed and Aftermarket
Face Mount and Side Mount WOC

Test Date: 10/15/14
Report Date: 11/04/14



1.0 Report Issued To:

2.0 Test Laboratory:

3.0 Project Summary:

3.1 Product Type: Window Opening Control Device

3.2 Series/Model: 1700 Series Pre-Installed and After Market Face Mount and Side Mount WOCD

3.3 Compliance Statement: Results obtained are tested values and were secured by using the designated test method(s). Test specimen description and results are reported herein.

3.4 Test Date: 10/15/2014

3.5 Test Record Retention End Date: All test records for this report will be retained until October 15, 2018.

3.6 Test Location: Architectural Testing, Inc. test facility in York, Pennsylvania.

3.7 Test Sample Source: The test specimens were provided by the client. Representative samples of the test specimen(s) will be retained by Architectural Testing for a minimum of four years from the test completion date.

3.8 Drawing Reference: The test specimen drawings have been reviewed by Architectural Testing and are representative of the test specimen(s) reported herein. Test specimen construction was verified by Architectural Testing per the drawings located in Appendix B. Any deviations are documented herein or on the drawings.

3.9 List of Official Observers:

<u>Name</u>	<u>Company</u>
Michael D. Stremmel, P.E.	Architectural Testing, Inc.
Aaron M. Shultz	Architectural Testing, Inc.

4.0 Test Method(s):

ASTM F 2090 10, *Test Method for Window Fall Prevention Devices with Emergency Escape (Egress) Release Mechanisms (Sections 8.5 through 8.8).*



5.0 Test Specimen Description:

5.1 Window Description: The window opening control device was installed onto an extruded vinyl hung window.

5.2 Product Sizes:

Overall Area: 1.1 m ² (11.9 ft ²)	Width		Height	
	millimeters	inches	millimeters	inches
Overall size	876	34-1/2	1264	49-3/4

5.3 Opening Control Device Description:

5.3.1 Test Specimen #1: The Pre-Installed window opening control device was constructed of one vinyl piece and a steel wire spring. The device had overall dimensions of 2" tall, 7/16" wide, and 11/16" deep. When assembled, the device utilized a single action to disengage the limit device. The single action required that the vinyl piece be pushed or pulled down and the device disengaged its vinyl keeper. The limit device utilized a wire spring which was utilized to keep the device engaged and assist in deploying the device for emergency disengagement. The device was manually disengaged. When the device was passed over by the sash, the device automatically reset to the engaged position upon returning the sash to the closed position. Two devices were installed into a pre grooved out slot on the interior sash jambs, located 2-7/8" above the meeting rail.

5.3.2 Test Specimen #2: The After Market window opening control device was constructed of one vinyl piece and a steel wire spring. The device had overall dimensions of 1-3/4" tall, 1 1/16" wide, and 1-1/16" deep. When assembled, the device utilized a single action to disengage the limit device. The single action required that the vinyl piece be pushed or pulled down and the device disengaged its vinyl keeper. The limit device utilized a wire spring which was utilized to keep the device engaged and assist in deploying the device for emergency disengagement. The device was manually disengaged. When the device was passed over by the sash, the device automatically reset to the engaged position upon returning the sash to the closed position. The device was secured to the window with two #8 x 1/2" long pan head screws. Two devices were utilized on the window, at each jamb, located 3-3/4" above the meeting rail.



6.0 Test Results The temperature during testing was 22°C (72°F). The results are tabulated as follows:

Test Specimen #1:

Title of Test	Results	Allowed	Note
Action to Disengage	One action per device	Two actions or one dual action	1
Window Opening Size	2-7/8"	<4"	
Operating Force	9 lbf	15 lbf max	
Static Load Test 75 lbf (Load was applied for 10 seconds) (5 cycles)	No damage	No damage	
Operational Cycling 4000 cycles	No damage	No damage	2, 3
Static Load Test 75 lbf (Load was applied for 10 seconds) (100 cycles)	No damage	No damage	
Window Opening Size	2-7/8"	<4"	
Operating Force	9 lbf	15 lbf max	

Note 1: The device required a single action to disengage. Two devices were present on the window to meet the two action requirement.

Note 2: The device was manually disengaged and the sash was opened past the opening control device. The sash was returned to the closed position and a visual inspection was taken ensuring the automatic re-engagement of the window opening control device.

Note 3: Minor cosmetic wear marks visible.

General Note: All testing was performed in accordance with Sections 8.5 through 8.9 of the referenced standard. The window opening control devices utilized on the test unit met all of the requirements for Window Opening Control Devices set forth in ASTM F 2090-10. At the completion of testing, the device was fully operational. The device, once released, automatically reset (Section 4.18).



6.0 Test Results: (Continued)

Test Specimen #2:

Title of Test	Results	Allowed	Note
Action to Disengage	One action per device	Two actions or one dual action	4
Window Opening Size	3-1/2"	<4"	
Operating Force	9 lbf	15 lbf max	
Static Load Test 75 lbf (Load was applied for 10 seconds) (5 cycles)	No damage	No damage	
Operational Cycling 4000 cycles	No damage	No damage	5, 6
Static Load Test 75 lbf (Load was applied for 10 seconds) (100 cycles)	No damage	No damage	
Window Opening Size	3-1/2"	<4"	
Operating Force	9 lbf	15 lbf max	

Note 4: The device required a single action to disengage. Two devices were present on the window to meet the two action requirement.

Note 5: The device was manually disengaged and the sash was opened past the opening control device. The sash was returned to the closed position and a visual inspection was taken ensuring the automatic re-engagement of the window opening control device.

Note 6: Minor cosmetic wear marks visible.

General Note: All testing was performed in accordance with Sections 8.5 through 8.9 of the referenced standard. The window opening control devices utilized on the test unit met all of the requirements for Window Opening Control Devices set forth in ASTM F 2090-10. At the completion of testing, the device was fully operational. The device, once released, automatically reset (Section 4.18).



Appendix A
Photographs



Photo No. 1
Pre-Installed WOCD



Photo No. 2
After Market WOCD

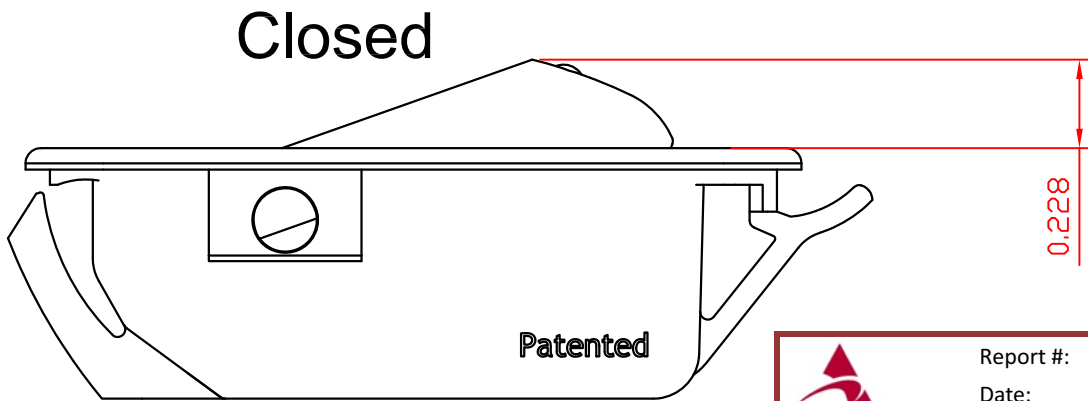
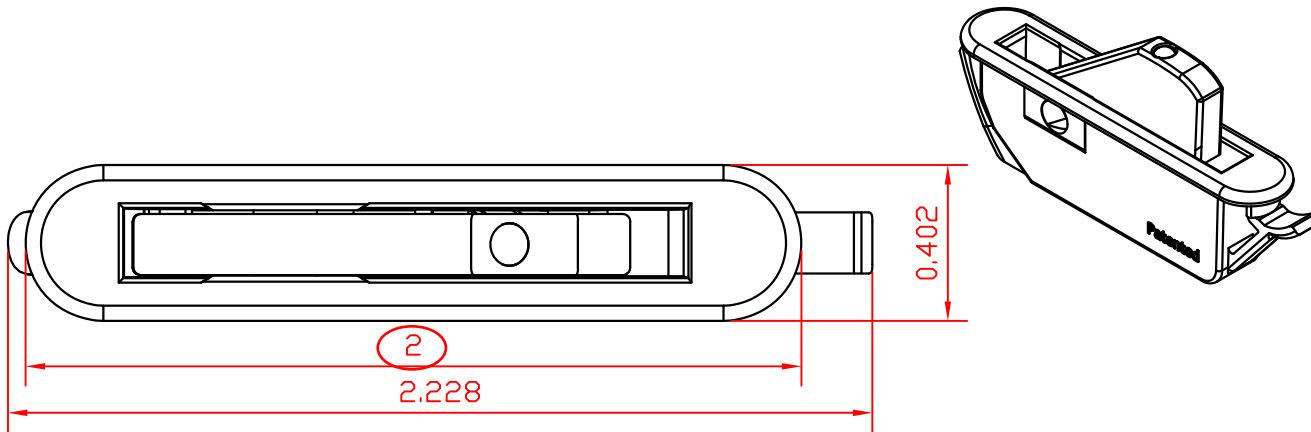
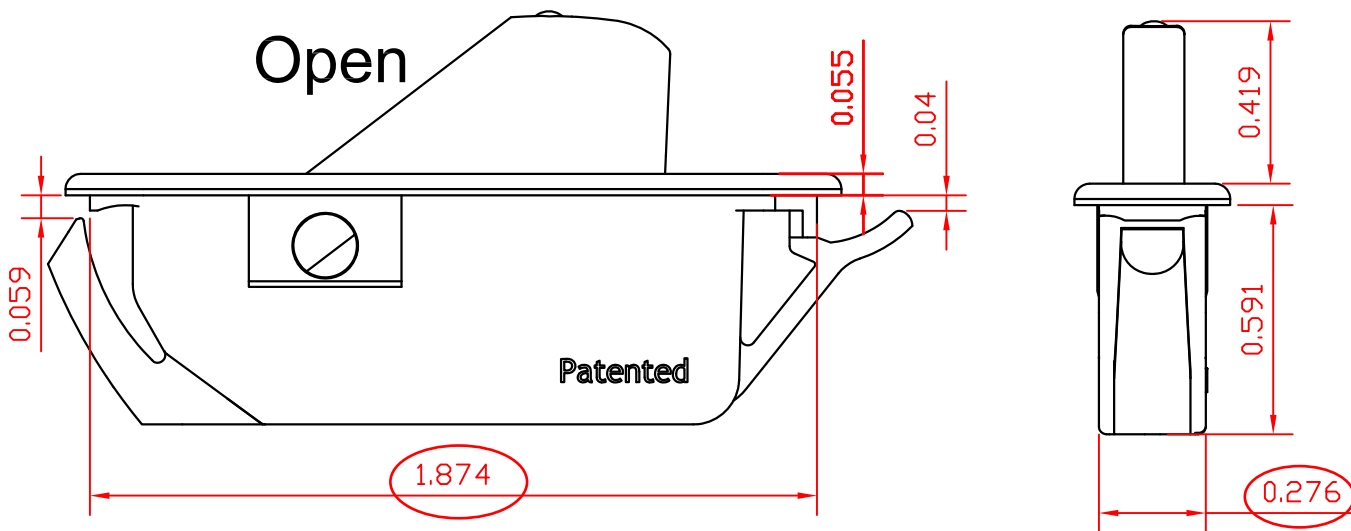

 Architectural Testing	Report #:	E1718.01-109-44
	Date:	10/17/14
	Verified by:	<i>AMJ</i>

The Information contained in this document or electronic media is property of Vision Industries Group, Inc. Any use or reproduction without expressed written consent is strictly prohibited.

1. Material 2. Unspecified Walls:.....in. 3. Unspecified Radii:.....in. 4. Tolerances: .xx - ±06 .xx - ±02 .xxx - ±005 .xxx - ±003 Angles ±1/2°	TITLE: 1761			DIE NO.
	PART NAME: WOOD			
	DESIGNER:	DRAWING NUMBER 1761-00		
	DRAWN BY: JIN	SCALE	MATERIAL	DATE
	APPROVED BY:	1:1		

1775-00L



Report #: E1718.01-109-44
 Date: 10/17/14
 Verified by: *AMS*

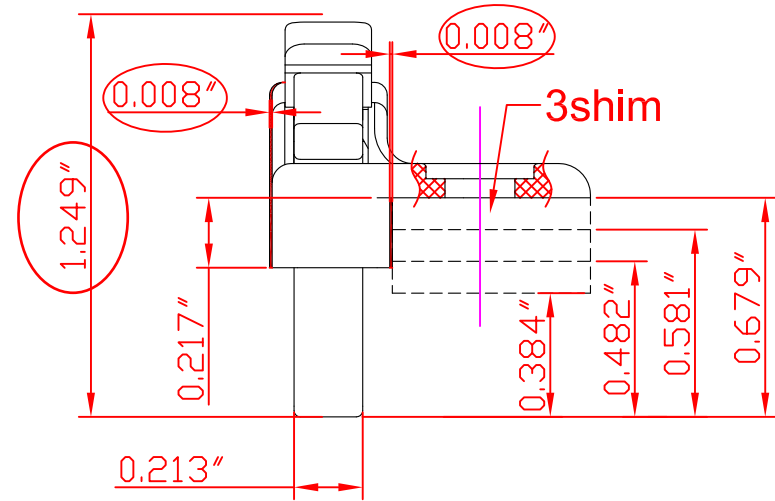
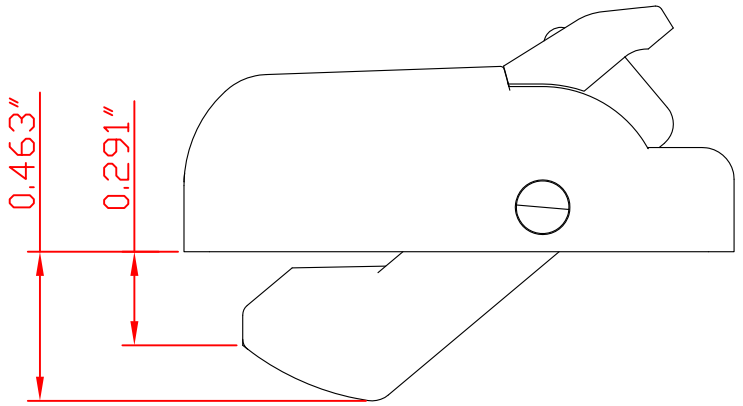
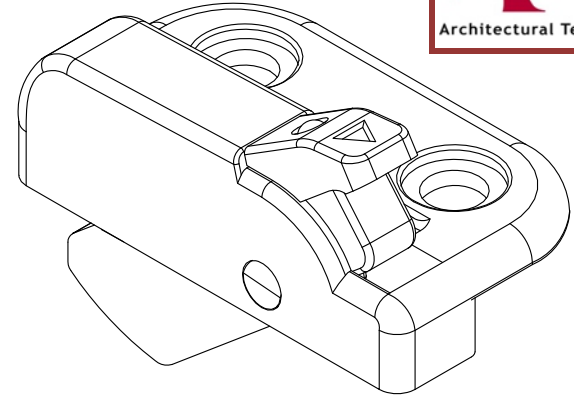
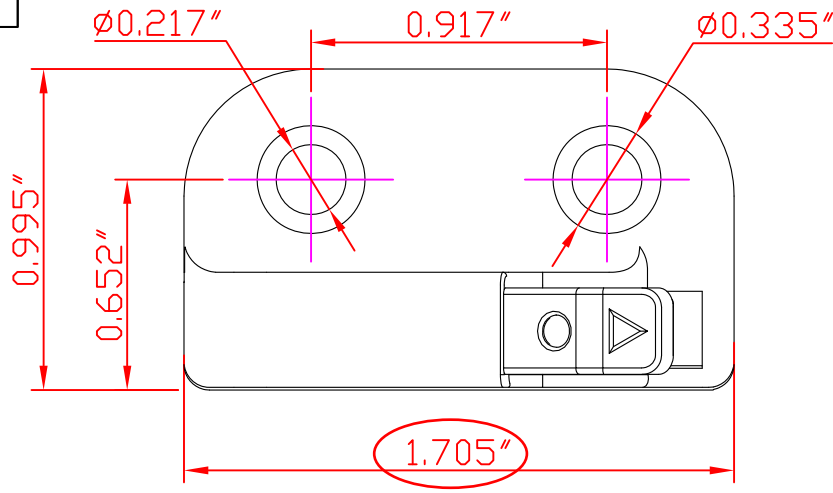

The Information contained in this document or electronic media is property of Vision Industries Group, Inc. Any use or reproduction without expressed written consent is strictly prohibited.

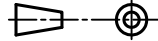
 1. Material 2. Unspecified Walls:.....in. 3. Unspecified Radii:.....in. 4. Tolerances: .xx - ±06 .xx - ±02 .xxx - ±005 .xxx - ±003 Angles ±1/2°					TITLE:1775LH			DIE NO.
					PART NAME: ASSEMBLY			
DESIGNER:					DRAWING NUMBER 1775-00L			
DRAWN BY: JIN					SCALE	MATERIAL	DATE	
APPROVED BY:					1:1	PA6+30GF	2010.08.23	
REV	MARK	CHG	DESCRIPTION	BY	DATE			