

Control Unit for Key Switch Type Generator

Model: ECU-05



ISO 9001/CNS 12681

McPherson Controls

4501 NW 27 Ave
Miami Florida 33142
305-634-1511 - Fax 305-634-1461

URL : www.mtspowerproducts.com **Email :** mcperson@mtspowerproducts.com

Auto Start Control Unit

1. USAGE

The ECU-05 Generator Auto Start Control, simply changes any manual key start generator to auto-start by automatically mimicking the action taken by someone turning the panel key and starting the generator manually.

The ECU-05 automatic initiation of the generators starting cycle by using the standard two-wire signals from any Automatic Transfer Switch or any standard remote mounted on/off switch.

In case the generator fails to start the first time, the ECU-05 tries two more times, preheating and turning the starter each time. All of this is programmable and adjustable by using the interval timers.

In Addition the ECU-05 can be adapted for use on Gasoline, and Gas powered engines by changing the DIP Switch position on the ECU-05

2. STANDARD FEATURES

- ◆ Inexpensive, small in size, low power consumption and easy to set up
- ◆ Connected by the use of a terminal block, Easy for installation and repairing.
- ◆ Operates with a single chip microprocessor, Epoxy encapsulation makes the ECU-04 dependable and reliable.
- ◆ The standard three attempts multi-start function can be factory modified by customer request.

3. ELECTRICAL CONNECTIONS

PIN No.	DESCRIPTION	NOTES
1	DC Plant Supply Input (+v)	System DC positive input (Battery Positive).
2	DC Plant Supply Input (-v)	System DC negative input (Battery Negative).
3	Programmed Pre-heat or Engine choke signal output	Used turn on the internal engine pre-heater Supply (+v) 30 Amp rated (If used)
4	Accessories "ON" Output	Connect to Key switch accessories ON position.
5	Starter signal Output	Used to control the Starter Motor Supply (+v). 30 Amp rated
6 & 7	Auxiliary Dry contact Output	OPEN when engine running CLOSE when engine failure or stop 20 Amp rated
8 & 9	Remote start Signal input	Connect to A.T.S device or Remote Switch
10 & 11	Generator AC sensing input.	Connect to alternator AC output.

4. TIME DELAY SETTING AND ALARM INDICATORS

- ◆ **VR1:** Pre-heat engine timer adjustment 1~25 seconds range - factory set for 5 seconds (Please refer to FIG-1 below)
- ◆ **VR2:** Starter cranking time adjustment 1~25 seconds range - refer to the generator user's guide 4 to 8 seconds suggested. (Please refer to FIG-1 below.)
- ◆ **L1:** Remote start activated indicator LED. (Please refer to FIG-1 below.)
- ◆ **L2:** Engine running normal indicator LED. (Please refer to FIG-1 below.)
- ◆ **L3:** Start fail indicator LED. (Please refer to FIG-1 below.)
- ◆ **SW:** ON for use on Diesel Engine with Pre-Heat, OFF for use on energize to STOP Diesel engines

Intended for easy installation on any generator that already has a manual key start, almost all connection to the ECU-05 control board are made directly to the back of the key switch, the ECU-05 automatically mimics the action taken by a person turning the panel key and starting the generator manually. The ECU-05 senses that the generator started by monitoring the output of the generator on terminals "10" and "11".

After installation, remove the key and simply start the generator by shorting terminal "8" and "9" on the ECU-05 board or by the remote start connection of any Automatic Transfer Switch. Any simple ON/OFF switch can also activate the ECU-05.

The manual start with the key works the same as before if you need to use it.

NOTE there are 2 methods of stopping the engine "Energize to STOP" and "Energize to START." You have to determine which engine type you have before you install the ECU-05

Terminal 3 is programmable

3 Can be used for Preheat or Energize to STOP depending on the DIP Switch position

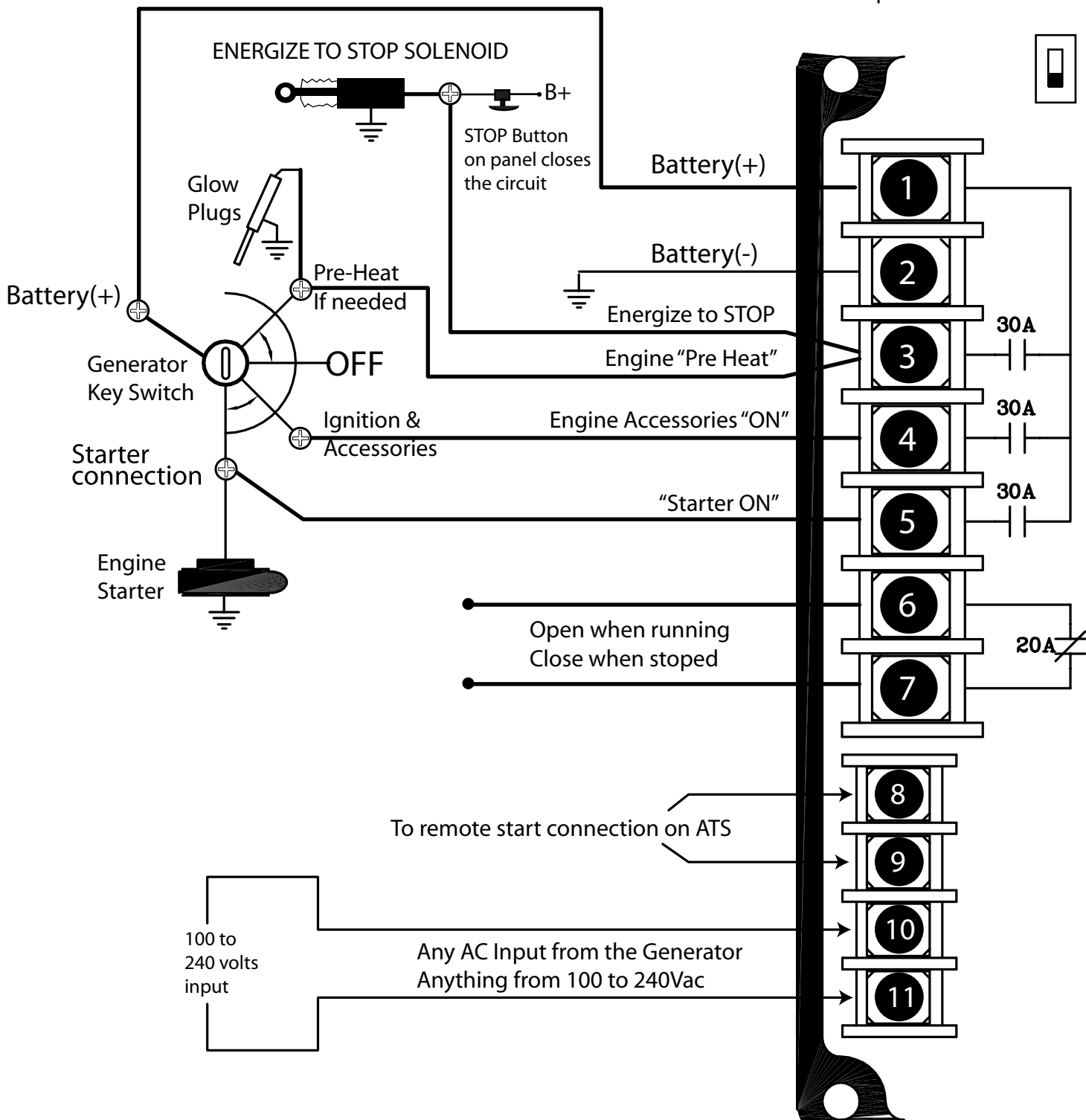
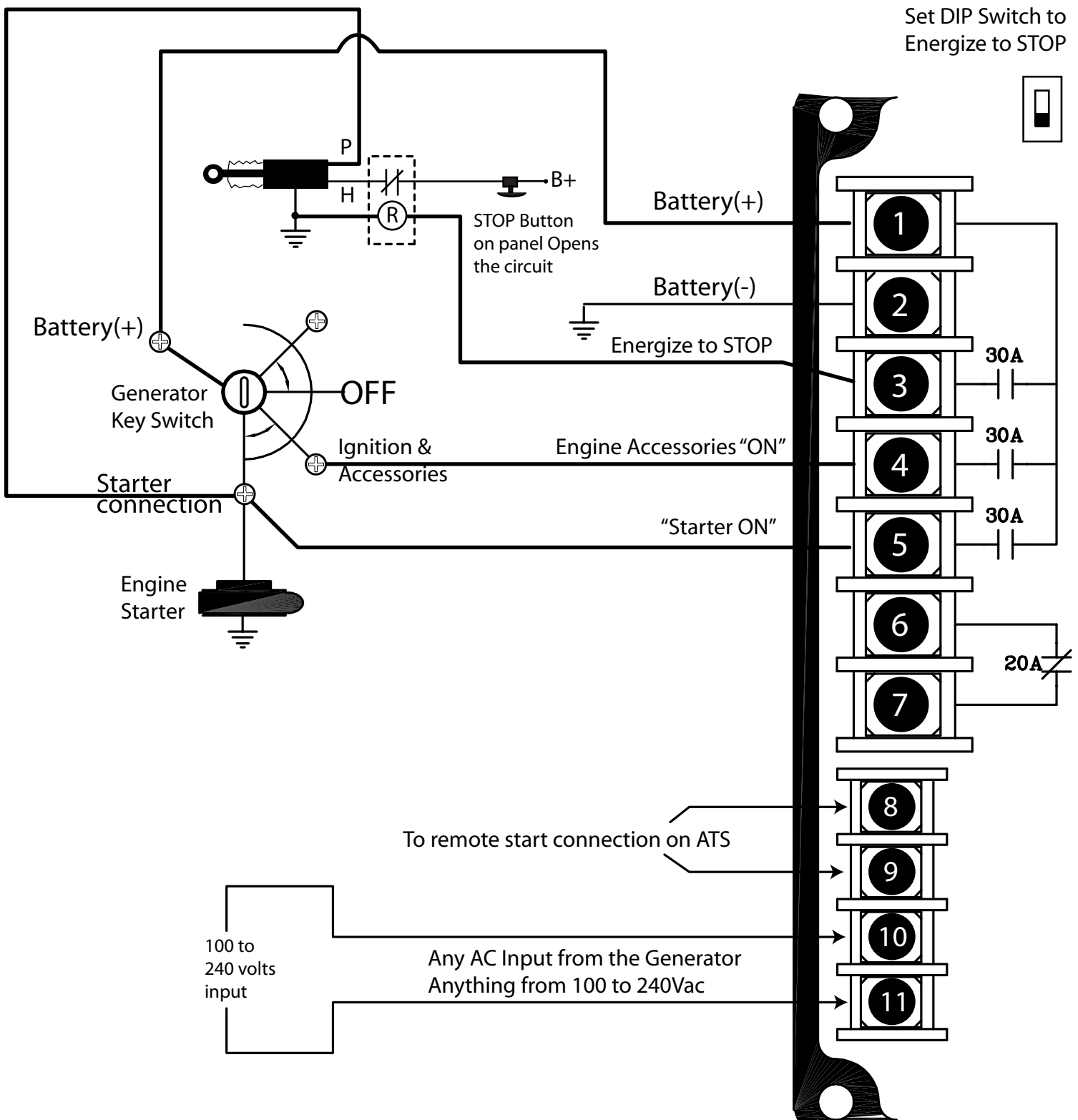

FIG 1

Some Chinese Generators have an Energize to START solenoid that is activated by the STARTER. The starter circuit also pulls the solenoid as it turns the starter, after the starter stops the HOLD circuit keeps the solenoid ON, and the only way to stop the engine is by breaking the power going to the hold solenoid circuit. The ECU-05 needs an added relay that is normally close to do this. Relay R is energized to break the circuit



Terminal 3 is programmable **3** Can be used for Preheat or Energize to STOP depending on the DIP Switch position

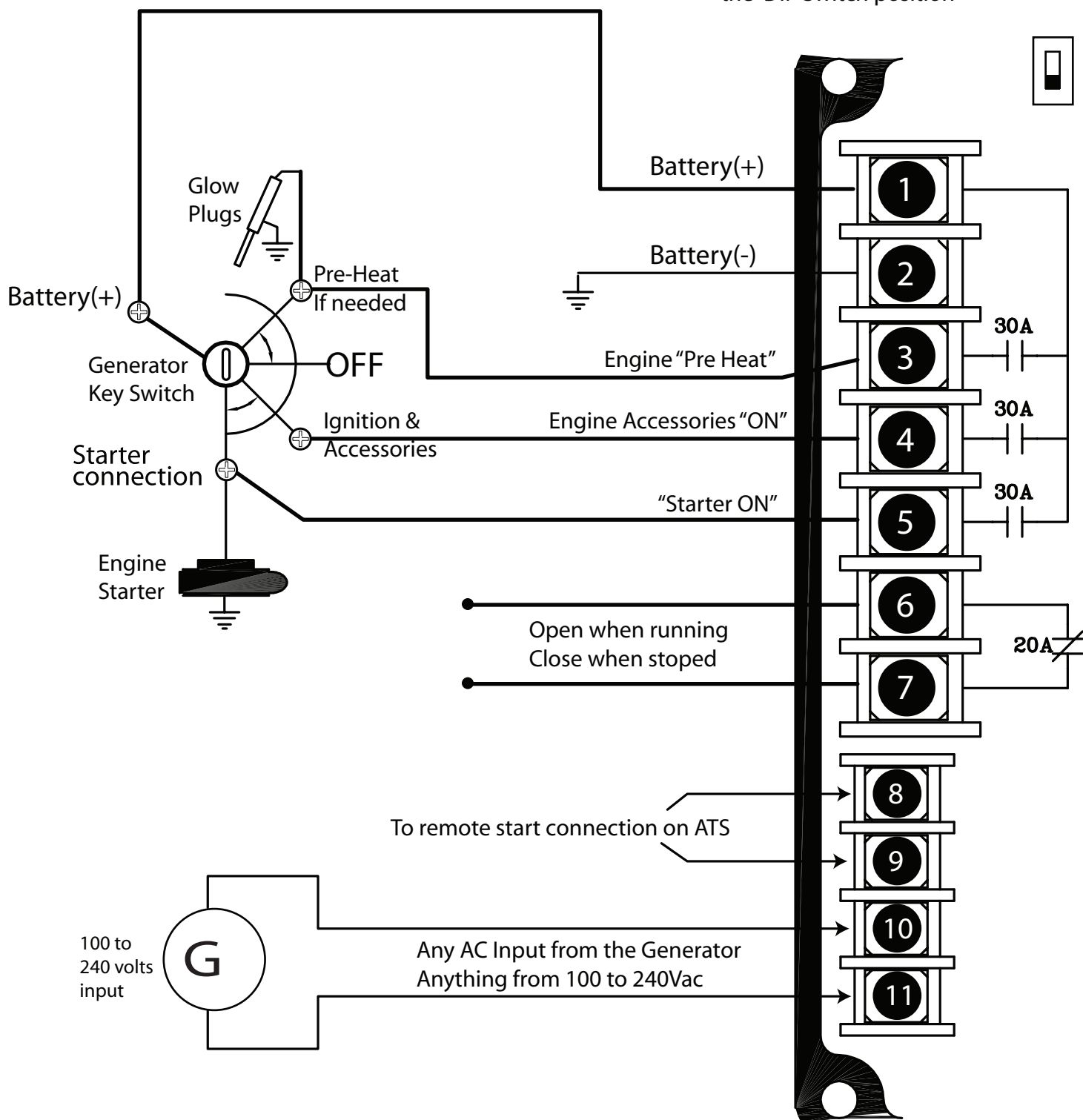

FIG 4