

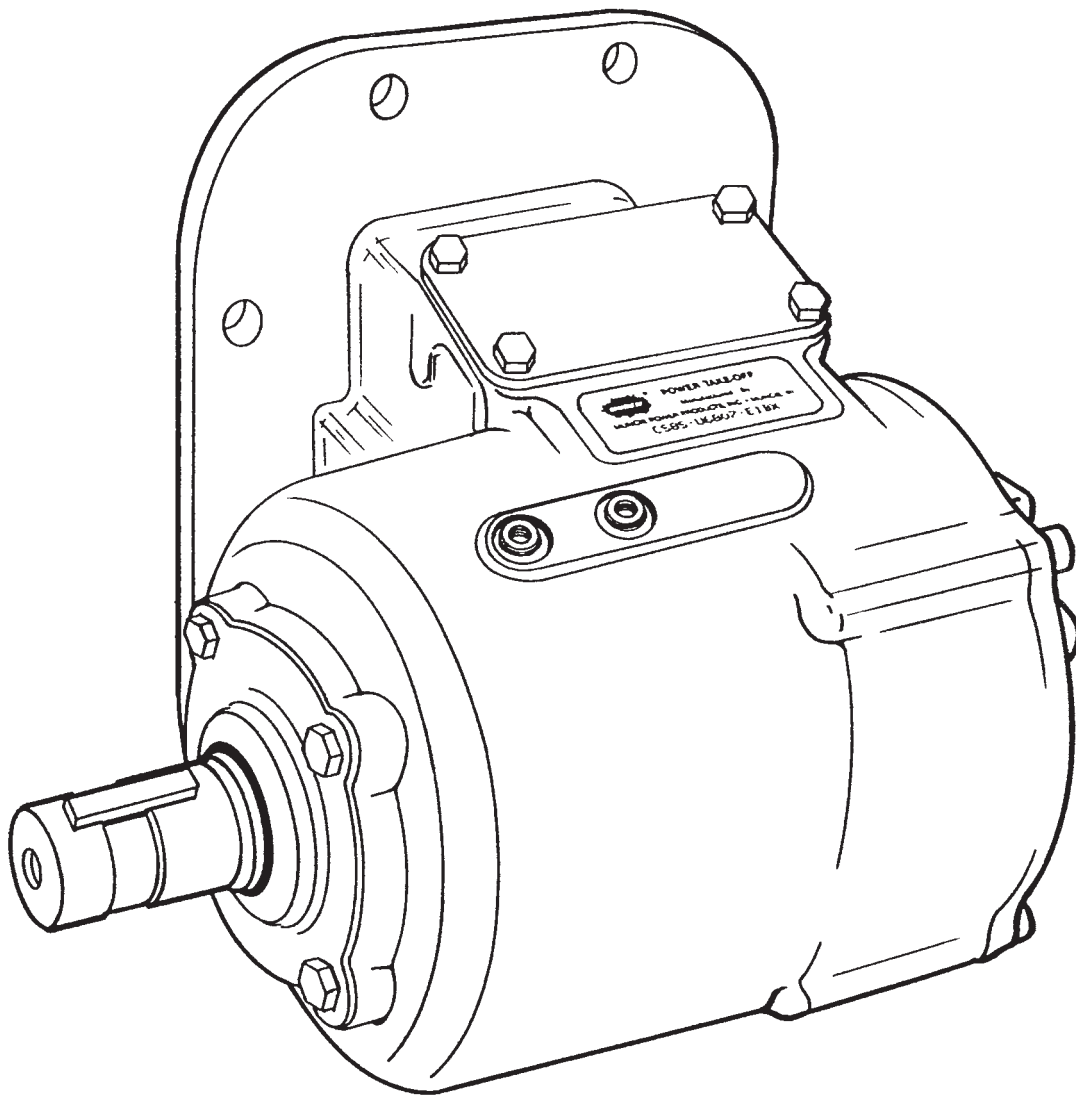

CS6, CS8, CB6 & CB8 SERIES

CLUTCH SHIFT PTO

PARTS LIST AND SERVICE MANUAL



CS6 & CS8 SERIES

EXPLODED VIEW

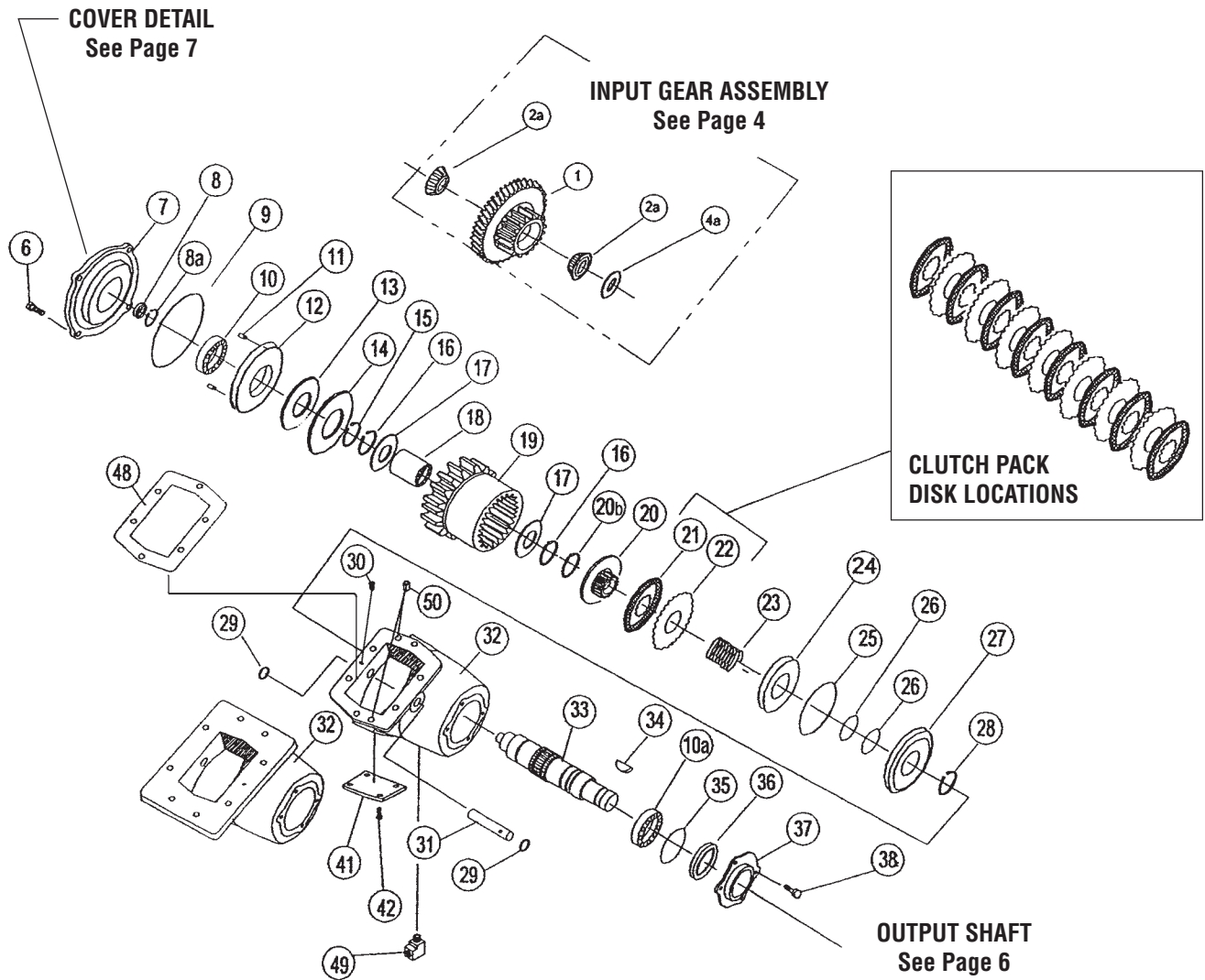

PARTS LIST AND DESCRIPTION

ITEM	QTY	PART NO.	DESCRIPTION	ITEM	QTY	PART NO.	DESCRIPTION
1	1		See Gear Data Chart Page 5 (Table A)			01T39411	6 Bolt Housing Special (39409)
2	2	10T34006	Input Bearing (03-04) – (A6705)			01T36715	8 Bolt Housing (03-04) '1' STD
2a	2	10T35776	Input Bearing (05-14)			01T36711	8 Bolt Housing (03-04) '3' STD
3	1	18T34622	Spacer (03-04) – (A6705)			01T37075	8 Bolt Housing (05-14) '1', '2' STD
4	4	21T34621	Thrust Race (03-04)			01T37074	8 Bolt Housing (05-14) '3', '4' STD
4a	1		See Chart Page 5 (Table B)			01T38350	8 Bolt Housing (05-14) '3' (I, D or Z)
5	2	10T34620	Thrust Bearing (03-04) – (A6705)			01T38351	8 Bolt Housing (05-14) '1' (I, D or Z)
6	4	19T35237	Capscrew			01T38856	8 Bolt Housing (05-14) '3' (E)
7	1	15T36717	Closed Cover Std.			01T38857	8 Bolt Housing (05-14) '1' (E)
		15T36860	Closed Cover (CS6G)	33	1		Output Shaft See Page 6
		15T39966	Closed Cover CB Series (see page 8)	34	1		Woodruff Key See Page 6
8	1	11T36124	Seal	35	1		O Ring See Page 6
8a	1	24T36894	Snap Ring	36	1		Seal See Page 6
9	1	12T34003	O-Ring	37	1		Output Flange See Page 6
10	1	10T21017	Bearing	38	4		Capscrew See Page 6
10a	1	10T21017	Bearing (std.)	41	1	16T41119	Cover
		10T38248	Bearing (I, D or Z)	42	4	19T41118	Capscrew
11	4	26T36175	Roll Pin (not included CS_G or CB_)	48	1	13M13541	Allison Gasket .031 (U60)
12	1	21T36473	Plate (not included CS_G or CB_)		1	13M35091	Gasket .010 6-Bolt
13	1	21T36511	Thrust Washer (not included CS_G or CB_)		1	13M35092	Gasket .020 6-Bolt
14	1	21T36512	Plate (not included CS_G or CB_)		2	13M35151	Gasket .010 8-Bolt
15	1	24T27240	Snap Ring		2	13M35152	Gasket .020 8-Bolt
16	2	24T35480	Snap Ring		1	13T35198	Gasket .010 (I85)
17	2	21T29017	Thrust Race		1	13T35199	Gasket .020 (I85)
18	1	10T36285	Bearing	49	1	43T37385	Orifice Fitting (P - Special Option)
18a	1	10T37008	Bearing (2 or 4 Assy - requires 18 & 18a) (see pg.4)	50	2	26T37992	Dowel Pin (F84 Only)
19	1		See Output Gear Chart Page 5 (Table C)				
20	1	02T38792	Clutch Hub				
20b	1	24T37951	Snap Ring (I, D or Z)				
21	8	49T33564	Friction Disc				
22	7	49T33563	Spacer Disc				
23	2	27T38791	Spring				
24	1	49T36560	Piston (CS8)				
		49T38878	Piston (CS6)				
		49T38387	Piston (I, D or Z)				
		49T38758	Piston (2 & 4 Assy)				
25	1	12T36054	O-Ring (CS8)				
		12T36472	O-Ring (CS6)				
26	2	12T36471	O-Ring				
		12T36053	O-Ring (I, D or Z)				
27	1	49T36561	Piston Cup — (CS8) (5.25" O.D.)				
		49T36464	Piston Cup — (CS6) (4.5" O.D.)				
		49T36115	Piston Cup (I, D or Z) (5.25" O.D.)				
		49T38757	Piston Cup (2 & 4 Assy) (5.25" O.D.)				
28	1	24T36470	Snap Ring				
		24T36040	Snap Ring (I, D or Z)				
29	2	12T35949	O-Ring (03-04) + (A6705)				
		12T35774	O-Ring (05-14)				
30	1	19T35785	Setscrew				
31	1	07T35947	Idler Shaft (03-04) + (A6705)				
		07T37071	Idler Shaft (05-14)				
32	1	01T36713	6 Bolt Housing (03-04) '1' STD & (A6705)				
		01T36706	6 Bolt Housing (03-04) '3' STD & (A6705)				
		01T37073	6 Bolt Housing (05-14) '1', '2' STD				
		01T37072	6 Bolt Housing (05-14) '3', '4' STD				
		01T37107	6 Bolt "N" Housing (05-14) '1' "N"				
		01T37106	6 Bolt "N" Housing (05-14) '3' "N"				
		01T37966	6 Bolt "F" Housing (05-14) '1' 'F' F84				
		01T37965	6 Bolt "F" Housing (05-14) '3' 'F' F84				
		01T39816	6 Bolt Housing (03-04) '1' (I, D or Z)				
		01T39817	6 Bolt Housing (03-04) '3' (I, D or Z)				
		01T38337	6 Bolt Housing (05-14) '3' (I, D or Z)				
		01T38338	6 Bolt Housing (05-14) '1' (I, D or Z)				

GASKET/SEAL KITS AND REBUILD KITS See Page 13

NOTE: A68 input is replaced by A67 input options.

CS6 & CS8 SERIES INPUT GEAR ASSEMBLIES

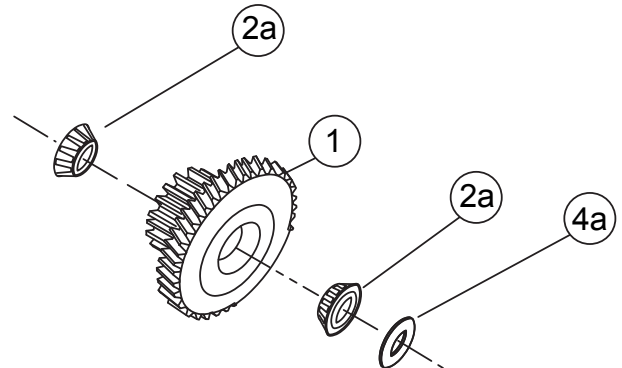
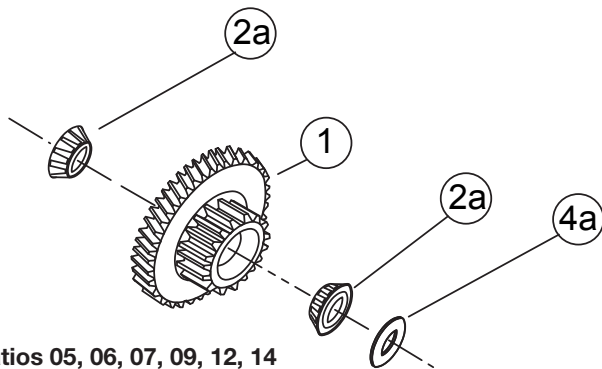
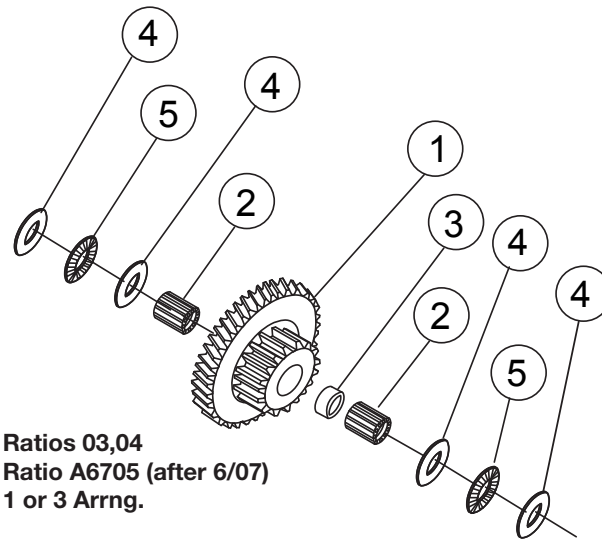

ITEM	QTY	PART NO.	DESCRIPTION
1	1	See TABLE A	Input Gear – Page 5
2	2	10T34006	Input Bearing (03 & 04)+(A6705)
2a	2	10T35776	Input Bearing (05 - 14)
3	1	18T34622	Spacer (03 & 04)+(A6705)
4	4	21T34621	Thrust Race (03 & 04)+(A6705)
4a	1	SEE TABLE B	Input Bearing Shims – Page 5

GEAR DATA

TABLE A — INPUT GEAR - ITEM 1

DESIG.	PART NO.	TEETH	GEAR DATA	DESIG.	PART NO.	TEETH	GEAR DATA
A6703	03T41318	26/14	6.86P 20° PA SPUR	M6507	03T37058	26/23	6.48P 17.65° PA Spur
A6704	03T41319	26/17	6.86P 20° PA SPUR	M6509	03T37059	26/26	6.48P 17.65° PA Spur
A6705	03T41320	26/18	6.86P 20° PA SPUR	M6512	03T37060	26/30	6.48P 17.65° PA Spur
**A6805	03T40699	26/18	6.86P 20° PA SPUR ≠	M8306	03T38760	30/20	8.38P 19.16°PA 24 ° 58' LH (2&4 Assy)
*A6907	03T37980	30/23	6.86P 20° PA SPUR	M8307	03T38761	30/23	8.38P 19.16°PA 24 ° 58' LH (2&4 Assy)
C6112	03T37067	20/30	6.1P 25° PA 32.28° LH	M8309	03T38762	30/26	8.38P 19.16°PA 24 ° 58' LH (2&4 Assy)
C7009	03T37652	23/26	7P 25° PA 30.78° LH	S6007	03T37061	21/23	6P 17.5° PA 26.17° LH
C7012	03T37068	23/30	7P 25° PA 30.78° LH	S6807	03T37062	26/23	6/8P 20° PA Spur
F1012	03T37984	42/30	10.1P 20° PA SPUR	S6809	03T37063	26/26	6/8P 20° PA Spur
F1107	03T37156	42/23	10.1P 21.5° PA SPUR	S6812	03T37064	26/30	6/8P 20° PA Spur
F6107	03T37147	21/23	6.1P 20.5° PA 29 LH	S6814(8-Bt)	03T37110	26/33	6/8P 20° PA Spur
F6307	03T37086	24/23	6.35P 20° PA 22° LH	S7009	03T37065	24/26	7P 17.5° PA 28.07° LH
F6309	03T38356	24/26	6.35P 20° PA 22° LH	S7107	03T37149	29/23	7P 17.5° PA 18° LH
F6312	03T37087	24/30	6.35P 20° PA 22° LH	S7109	03T37134	29/26	7P 17.5° PA 18° LH
F6607	03T38502	24/23	6.65P 20° PA 21.5° LH	S7307	03T37919	28/23	7P 22.5° PA 19° LH
F6609	03T38503	24/26	6.65P 20° PA 21.5° LH	S7309	03T38171	28/26	7P 22.5° PA 19° LH
F6612	03T38504	24/30	6.65P 20° PA 21.5° LH	S7312	03T38170	28/30	7P 22.5° PA 19° LH
F7005	03T38195	26/18	7P 23° PA 26 LH	U6003	03T36737	24/14	6P 20° PA Spur
F7007	03T38194	26/23	7P 23° PA 26 LH	U6004	03T36738	24/17	6P 20° PA Spur
F7009	03T40234	26/26	7P 23° PA 26 LH	U6005	03T37069	24/18	6P 20° PA Spur
F8405	03T37741	28/18	8.38P 18° PA 33.1 LH	U6806	03T38262	24/20	6/8P 20° PA Spur
F8407	03T37742	28/23	8.38P 18° PA 33.1 LH	U6807	03T37038	24/23	6/8P 20° PA Spur
F8409	03T37743	28/26	8.38P 18° PA 33.1 LH	U6809	03T37039	24/26	6/8P 20° PA Spur
F8412	03T37908	28/30	8.38P 18° PA 33.1 LH	U6812	03T37040	24/30	6/8P 20° PA Spur
F8507	03T37066	34/23	8.55P 21° PA SPUR	U6814(8-Bt)	03T37042	24/33	6/8P 20° PA Spur
F8607	03T39447	28/23	8.38P 18° PA 33.1 RH	U6005	03T38803	24/18	6P 20° PA Spur(2&4 Assy)
F8609	03T39448	28/26	8.38P 18° PA 33.1 RH	U6809	03T38801	24/26	6/8P 20° PA Spur(2&4 Assy)
I8403	03T37329	34/14	8.46P 20° PA SPUR	**Produced after 06/07 uses needle bearings and requires the 03-04 housing. A67 input gear replaces A68 input gear. * Requires 23M60270 and 20TK4360 to mount. ≠ Requires housing change to 03-04 housing on units date before 06/07.			
I8404	03T37330	34/17	8.46P 20° PA SPUR				
I8405	03T37331	34/18	8.46P 20° PA SPUR				
I8407	03T37332	34/23	8.46P 20° PA SPUR				
I8505	03T37091	38/18	8.46P 20° PA SPUR				
I8507	03T37092	38/23	8.46P 20° PA SPUR				
M6504	03T36775	26/17	6.48P 17.65° PA SPUR				
M6505	03T37070	26/18	6.48P 17.65° PA SPUR				

TABLE B — INPUT GEAR BEARING SHIMS - ITEM 4a (Shim Kit 18TK4586) (1 of ea.)

ITEM 4a	DIMENSION	ITEM 4a	DIMENSION	ITEM 4a	DIMENSION
18T35783	Shim 0.1150 / 0.1130	18T38727	Shim 0.1275 / 0.1255	18T37151	Shim 0.1400 / 0.1380
18T38725	Shim 0.1175 / 0.1155	18T36230	Shim 0.1300 / 0.1280	18T38730	Shim 0.1425 / 0.1405
18T35782	Shim 0.1200 / 0.1180	18T38728	Shim 0.1325 / 0.1305	18T37152	Shim 0.1450 / 0.1430
18T38726	Shim 0.1225 / 0.1205	18T36229	Shim 0.1350 / 0.1330	18T38731	Shim 0.1475 / 0.1455
18T35781	Shim 0.1250 / 0.1230	18T38729	Shim 0.1375 / 0.1355	18T37153	Shim 0.1500 / 0.1480

TABLE C — OUTPUT GEAR - ITEM 19

PART NO.	RATIO	TEETH	PART NO.	RATIO	TEETH	PART NO.	RATIO	TEETH
02T36744	03	42T	02T36750	14	23T	02T38994	12	26T I&Z Output
02T36745	04	39T	02T38988	03	42T I&Z Output	02T38995	14	23T I&Z Output
02T36746	05	38T	02T38989	04	39T I&Z Output	02T38763	05	38T 2&4 Ass'y
02T37913	06	36T	02T38990	05	38T I&Z Output	02T38764	06	36T 2&4 Ass'y
02T36747	07	33T	02T38991	06	36T I&Z Output	02T38765	07	33T 2&4 Ass'y
02T36748	09	30T	02T38817	07	33T I&Z Output	02T38766	09	30T 2&4 Ass'y
02T36749	12	26T	02T38992	09	30T I&Z Output	02T41324	03	42T (A67)
						02T41325	04	39T (A67)
						02T41326	05	38T (A67)

CS6 & CS8 SERIES OUTPUT GEAR 2 OR 4 ASSEMBLIES

ITEM	QTY	PART NO.	DESCRIPTION
17	2	21T29017	Thrust Race
18	1	10T36285	Bearing
18a	1	10T37008	Bearing (2 or 4 Assy requires 18 & 18a)
19	1	See TABLE C	Output Gear – Page 5

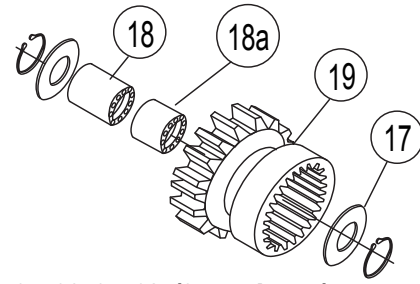

Ratios 05, 06, 07, 09 (2 or 4 Arrng.)

OUTPUT SHAFT & FLANGE

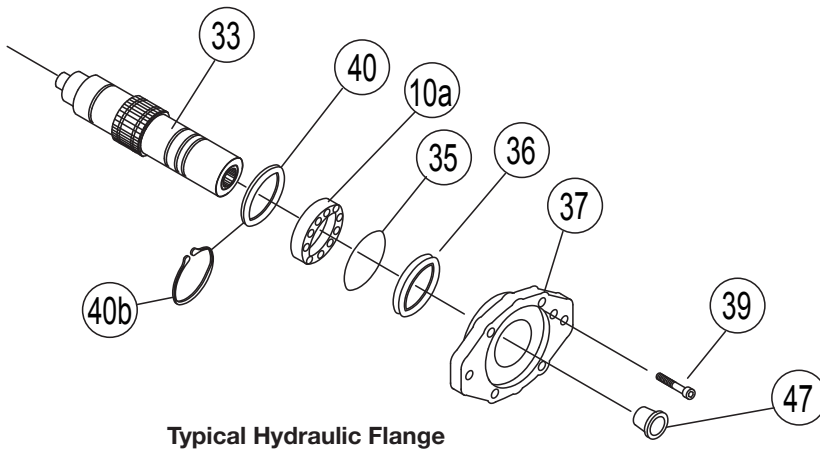

Typical Hydraulic Flange

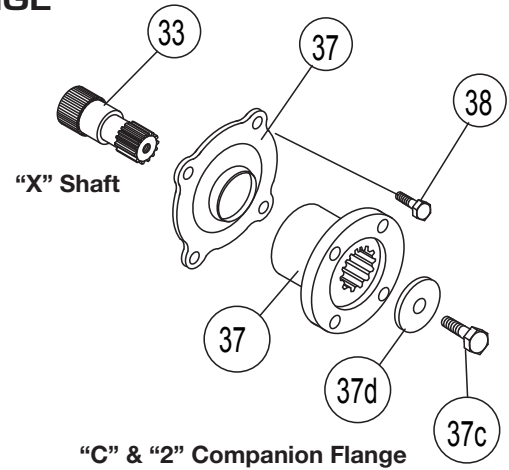

"C" & "2" Companion Flange

ITEM	QTY	PART NO.	DESCRIPTION	ITEM	QTY	PART NO.	DESCRIPTION
10a	1	10T21017	Bearing (std.)	37	1	15T34576	Bearing Cover, Open "B", "2", "C", "X"***
	1	10T38248	Bearing ("I", "D" or "Z")			14T37779	Hyd Flange "K" "P"
33	1	06T36892	Output Shaft "B" 1-1/4" Rd			14T39137	Hyd Flange "G"
		06T37088	Output Shaft "G" Dana Special			14T38354	Hyd Flange "I"
		06T41013	Output Shaft "D" DIN 5462 (with special mounting hole)			14T39406	Hyd Flange "I" (CS6G), "D" (std. end cover)
		06T36893	Output Shaft "K" 7/8"-13 Spl			14T39141	Hyd Flange "Q" "R" & "T"
		06T37090	Output Shaft "Q" & "S" 7/8"-13 Spl			14T35464	Hyd Flange "S"
		06T37089	Output Shaft "P" "L" 1"-15 Spl			14T38343	Hyd Flange "Z"
		06T38964	Output Shaft "R" 5/8"-9 Spl			14T37378	"2" Companion Flange
		06T37336	Output Shaft "T" 3/4"-11 Spl			14T37357	"C" Companion Flange
		06T37372	Output Shaft "2", "C", "X" 20 Spl			14T38981	Hyd Flange ("6")
		06T37167	Output Shaft "B" (CS6G)			14T40714	Flange "L" – (for Low Box – pg. 15)
		06T37168	Output Shaft "K" & "6" (CS6G)	37c	1	19M38266	Capscrew ("2", "C", "X")
		06T39526	Output Shaft "I" CS6G DIN 5462	37d	1	21T20092	Flat Washer ("2", "C", "X")
		06T38996	Output Shaft "I" Std. DIN 5462 (same as "D" without special hole)	38	4	19T33233	Capscrew ("B")
		06T38908	Output Shaft "Z" 1-1/4"-14 Spl	39	4	19T34462	Socket Capscrew "K" "P" & "Z" "L" Hyd
		06T38767	Output Shaft "B" 2 or 4 Assy			19T39257	Socket Capscrew "G" "Q" "S" "R" "T" Hyd
		06T39533	Output Shaft "K" 2 or 4 Assy			19M84478	Socket Capscrew "I" "D"
		06T40236	Output Shaft "P" 2 or 4 Assy			19T96512	Socket Capscrew "I" CS6G
		06T40205	Output Shaft "E" Special Order 1-1/4"-14 Spl	39	8	19M84478	Capscrew (E) 8 Req.
34	1	26T01627	Woodruff Key	40	1	28T36546	Spacer, Hyd Output
35	1	12T36751	O Ring	40b	1	24T38347	Snap Ring I, Z, D
		12T38344	O Ring ("I" "D" & "Z")	47	1	25T35724	Cap Plug "K" "S" "Q" "G" (Storage Only)
36	1	11T37790	Seal			25T35725	Cap Plug "P" (Storage Only)
		11T37795	Seal ("E" "I" "D" & "Z")	*** It is recommended to use Loctite #640 on outside of seal when replacing seal in this bearing cover.			

CS6, CS8 SERIES

ITEM #7 END COVER DETAIL

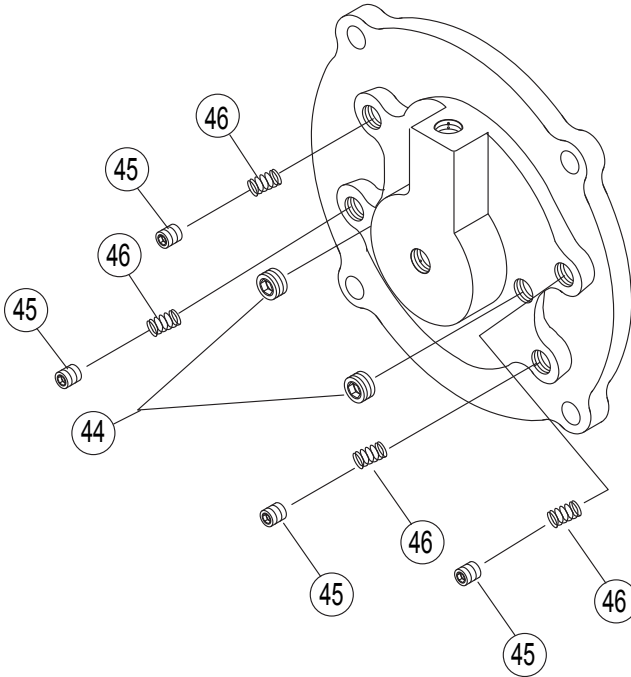

CS6S, 6B, 6N, CS8S, 8B

ITEM	QTY	PART NO.	DESCRIPTION
44	2	25T21684	Pipe Plug
45	4	19T36174	Setscrew
46	4	27T36173	Spring

**CB6/8 COVER
DETAIL ON PG. 8**

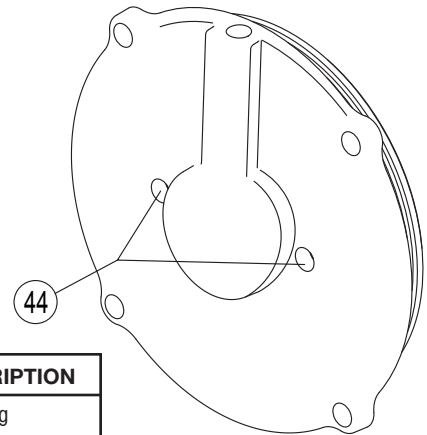

CS6G, CS8G

ITEM	QTY	PART NO.	DESCRIPTION
44	2	25T21684	Pipe Plug

ASSEMBLY OF 2 OR 4 ARRANGEMENT CS6/8

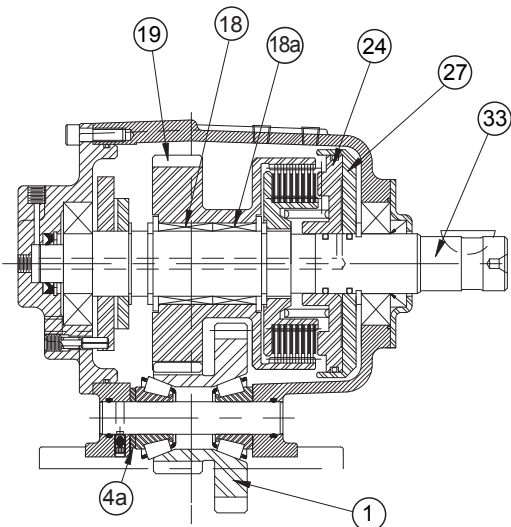

2 or 4 Arrangement

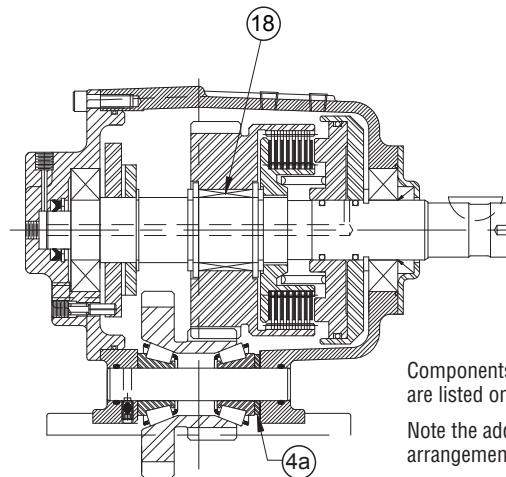

1 or 3 Arrangement

Components for the 2 & 4 arrangement are listed on pages 3,4 ,5 &6.

Note the additional bearing in the 2/4 arrangement PTO.

Note the location of the input gear shim 4a on each assembly.

CB6 & CB8 SERIES EXPLODED VIEW

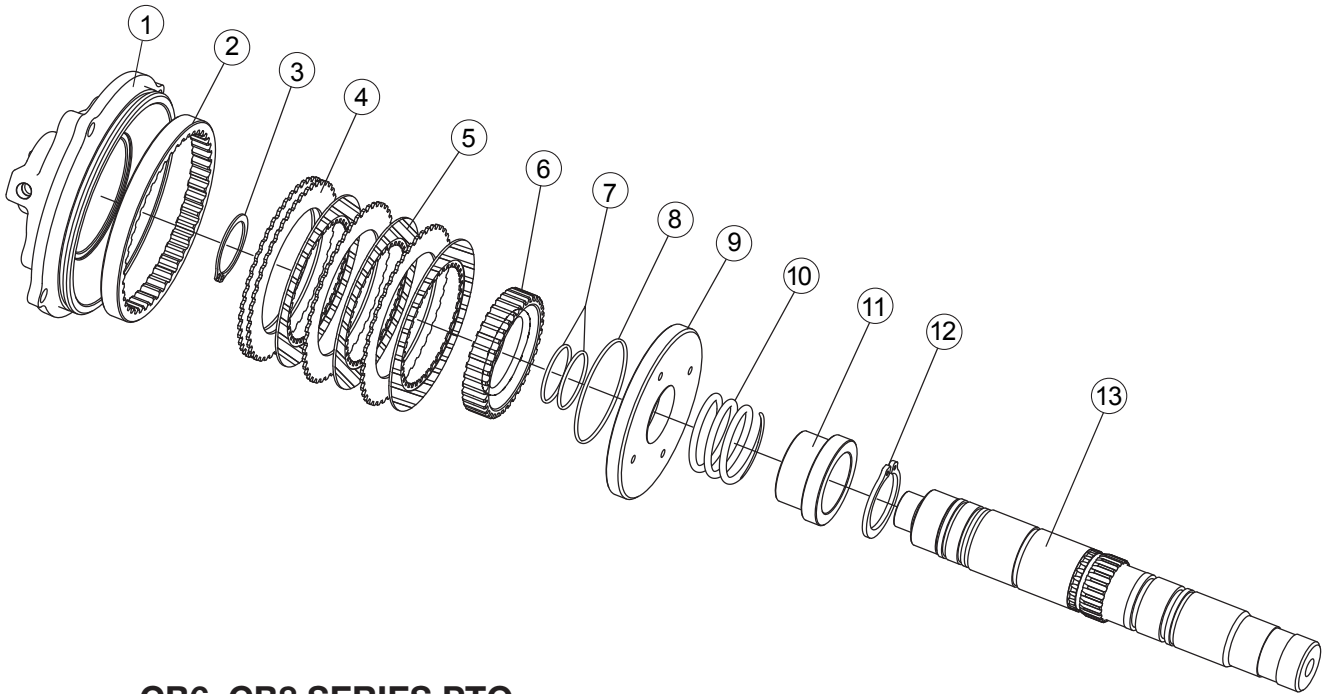

CB6, CB8 SERIES PTO WITH HI-TORQUE BRAKE

ITEM	QTY.	PART NO.	DESCRIPTION
1	1	15T39966	Cover
2	1	28T39965	Brake Ring
3	1	24T24315	Snap Ring
4	add 4	49T33563	Spacer Disc
5	add 3	49T33564	Friction Disc
6	1	28T39964	Brake Hub
7	2	12T35343	O-Ring
8	1	12T39967	O-Ring
9	1	28T39963	Piston
10	1	27T40389	Spring
11	1	28T40390	Spacer
12	1	24T35480	Snapping
13	1	06T39874	1-1/4 Rd. Shaft
		06T40812	"K" Hyd. Shaft
14	2	25T21684	Pipe Plug

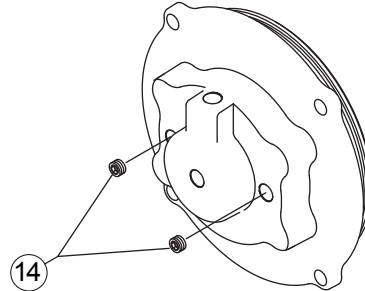

**Cover
Detail
(Backside)**

These components replace the drag brake components, Items 11,12,13,14,15 and items 7 & 33 found on page 2 & 3. The clutch plates and discs are additional to the ones shown on page 2 & 3.

End cover (item 1) shown here uses the seal and snap ring (items 8 and 8a) shown on pages 2 & 3 and are not shown here.

The CB series is only available with the standard round output shaft, 1-1/4 round with key and the Hydraulic SAE B 7/8" 13T spline, and only arrangements 1 or 3.

The CB series brake does not need to be adjusted.

CS6 & CS8 SERIES

CS6S DISASSEMBLY AND REASSEMBLY

DISASSEMBLY PROCEDURE (REFERENCE EXPLODED VIEW ON PAGE 2)

1. Remove the CS6S input gear, by removing the set screw in the pad and driving the idler shaft from the housing. (Items 30,32)
2. Remove the set screws (Item 45) from the bearing cover (Item 7) which hold the drag brake springs (Item 46). Position the housing so that the springs fall from housing.
3. Remove the four (4) capscrews (Item 6) which hold the back cover to the PTO housing.
4. Position the housing against a bench block and hit the end of the output shaft with a soft face hammer to remove the entire output shaft assembly with wbearing cover.
5. Remove the two (2) pipe plugs (Item 44) from the bearing cover. This exposes the ball bearing assembly within the cover.
6. Using a 1/4" punch and alternating between the two holes, drive the bearing and shaft assembly from the bearing cover.
7. Using a bearing puller remove the rear bearing (Item 10) by grabbing the drag brake plate (Item 12) and removing both pieces. The bronze brake disk (Item 13) can be removed.
8. Using a bearing puller remove the drag brake rotor (Item 14) .
9. The piston and clutch pack may be serviced without removal of the drag brake. Using snap ring pliers, remove the snap ring (Item 28) located on the output shaft end while gently pushing on the piston cup (Item 27).
10. Pull the piston cup (Item 27) from the shaft and the piston (Item 24) will go with it.
11. Tap the piston cup on a wood surface to remove the piston.
12. Remove the spring (Item 23). The clutch friction discs (Item 21) and spacer discs (Item 22) and inner clutch hub (Item 20) can be removed by pointing the shaft end down.
13. With the drag brake removed, the snap rings (Item 15 & 16) on this end of the bell gear can be removed with snap ring pliers. This allows the bell gear to be removed towards the closed end. The internal bearing (Item 18) of the bell gear can easily be removed.

▽ - DENOTES SPECIAL SERVICE PROCEDURES

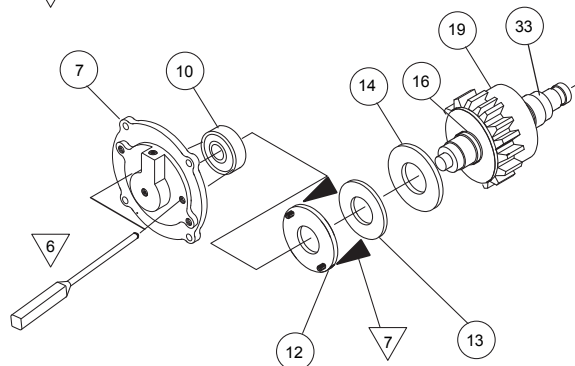

REASSEMBLY PROCEDURE

14. The reassembly of the unit is made in reverse of the disassembly.
15. Be sure to lubricate the o'rings and all bearings upon installation.
Torque capscrews to the values shown or to the following values.
 - 1/4 set screw - 9 ft. lb.
 - 5/16 capscrews - 18 ft. lb.
 - 5/16 Hyd. Flange CS - 25 ft.lbs.
 - 3/8 capscrews - 36 ft. lb.
16. Place the input bearing into the input gear and slide this group into the housing to line up the idler shaft.

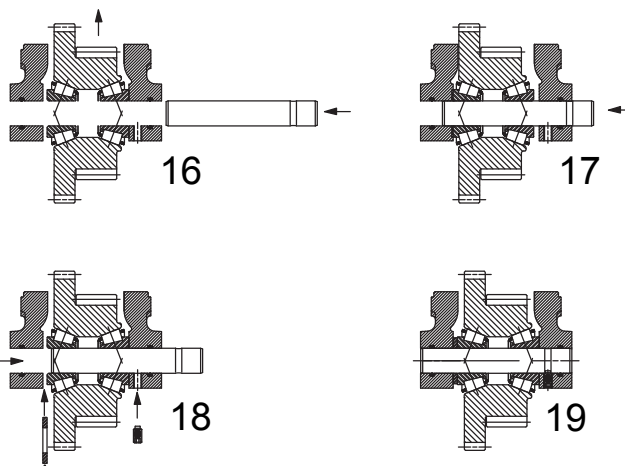

TAPERED ROLLER BEARING INSTALLATION:

17. Tap the idler shaft into the housing and through both bearing races.
18. To seat the bearings, tap the idler shaft in the reverse direction while rotating the gear back and forth. Move the shaft so that it is flush with the bearing in this assembly. Position the PTO so that the idler shaft is pointed down and perpendicular to the table. Insert the thickest shim that can be installed by hand in the gap between the bearing and the housing. Rotate the input gear to ensure it is not excessively tight or loose. Using a feeler gauge, measure the clearance between the shim and the bearing race. Recommended bearing clearance is .002" loose to .006" loose. If measurement is less than .002" then remove the shim and replace it with the next thinner shim. If the measurement is greater than .006" then remove the shim and replace with the next thicker shim.

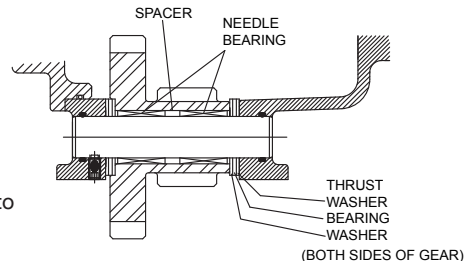

NEEDLE ROLLER BEARING INSTALLATION:

17. Be sure to place the thrust washer and thrust bearing on each side of the input gear prior to inserting gear assembly into housing.
18. This does not require measuring the preload of the bearings. Be sure to align the washers and bearings in the idler shaft as the shaft is inserted into the housing.
19. Tap the idler shaft into position and install the set screw.

DRAG BRAKE ADJUSTMENT (the GB series brake does not need to be adjusted)

20. When installing the rear cover be sure to align the roll pins in the drag brake plate with the holes in the rear cover.
21. After the cover has been attached to the housing insert the springs into the holes.
22. Insert the setscrew over the spring and turn the screw seven (7) full turns.
23. Follow the test and adjustment procedures in the PTO Owner's manual.

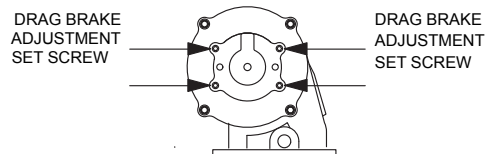

CLUTCHSHIFT SERIES ELECTRIC/AIR SHIFT INSTALLATION KIT 48TK3928

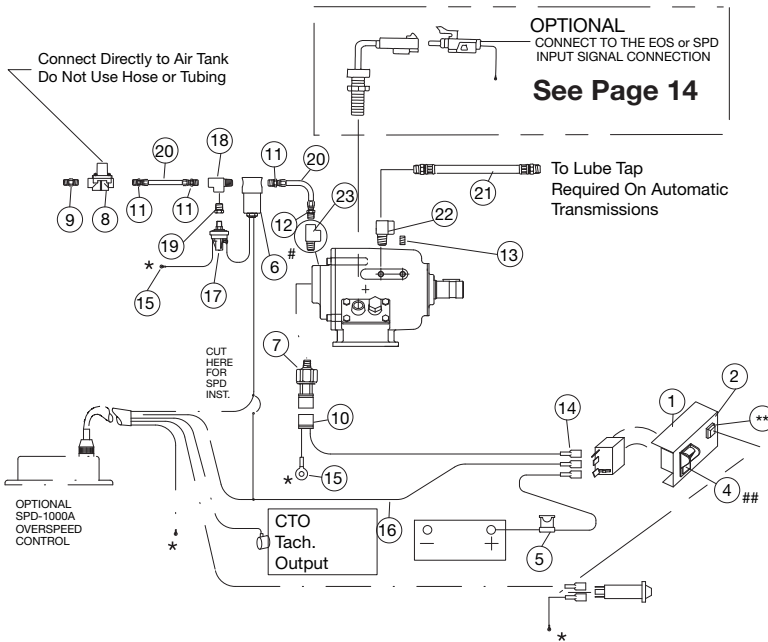

* Battery Ground

Solenoid to be mounted in engine compartment out of direct spray of road contaminants.

RED light to turn "ON" when PTO switch is activated.

ITEM	QTY	PART NO.	DESCRIPTION
		30T36270	Switch Assembly 12V (Incl 1,2,4)
1	1	36MA1005	Switch Bracket
2	1	36T36271	Face Plate W/O Light Access
4	1	30T35687	Rocker Switch 12v
5	1	33T36299	Fuse Assembly
6	1	35M30692	12v Solenoid Valve
7	1	30T37954	Pressure Switch
8	1	31M15759	Press. Protection Valve
9	1	44MB2164	Pipe Nipple
10	1	34T36941	Wiring Pigtail
11	2	44MB6844	Male Connector
12	2	44MB6842	Male Connector
13	1	25T21684	Pipe Plug (Use As Req.)
14	3	34M18250	Female Spade Connector
15	2	34M18009	Ring Terminal
16	12	37M18000	Electric Wire 12ft.
17	1	31M14732	Press. Safety Switch (N.O. 80 PSI)
18	1	44MB2254	Street Tee
19	1	44MB0942	Reducer Bushing
20	1	45M44430	Air Tubing 30ft
23	1	44MB2252	StreetTee
N.S.	1	48TA3953	Solenoid Bracket Kit
Additional Parts Included with "P" SPECIAL FEATURE			
21	1	45M4R536	Lube Hose Ass'y
22	1	43T37385	Orifice Fitting
NS	1	43M05522	Elbow (F85 Only)
NS	2	43T37429	Fitting (185 ONLY)
For 24V Electric/Air Kit No. 48TK3931, Substitute:			
		30T36453	Switch Ass'y 24v (Incl 1,2,4)
4	1	30T35712	Rocker Switch 24v
6	1	35M31692	Solenoid Valve 24v
For connection to SPD1001A use 36TK4971 (12v) (sold separately)			
**	1	32MSR12V	Light Assembly
	1	36M01006	Face Plate W/ Light Access
	2	34M18187	Spade Terminal

CLUTCHSHIFT SERIES ELECTRIC/HYDRAULIC SHIFT INSTALLATION KIT 48TK3927B

On automatic transmissions with externally, solenoid controlled converter neutral lock-up, install the ClutchShift activation circuit completely separate of the lock-up circuit. Do Not use the same valve to operate both circuits.

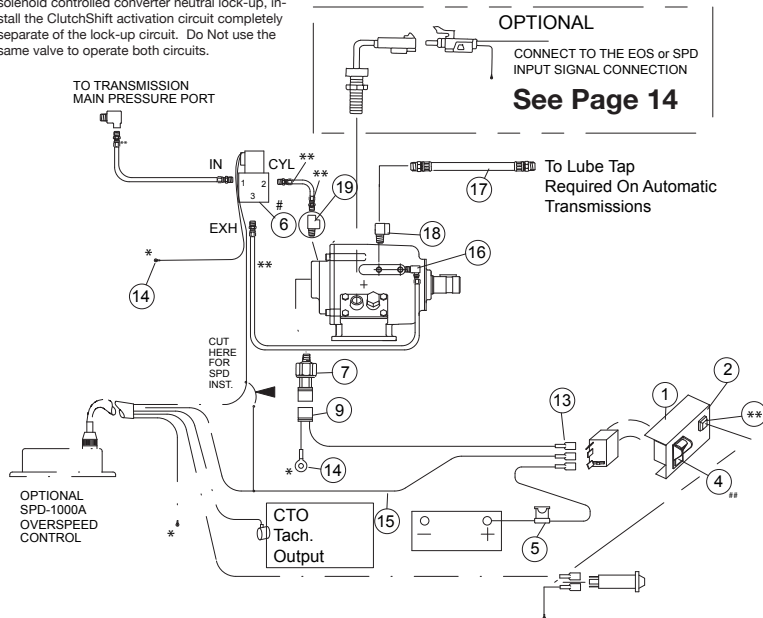

* Battery Ground

** Not Supplied with Standard Installation Kit. Order Muncie 131-2-0001 Separately.

Solenoid to be mounted in engine compartment out of direct spray of road contaminants.

RED light to turn "ON" when PTO switch is activated.

ITEM	QTY	PART NO.	DESCRIPTION
		30T36270	Switch Assembly 12V (Incl 1,2,4)
1	1	36MA1005	Switch Bracket
2	1	36T36271	Face Plate W/O Light Access
4	1	30T35687	Rocker Switch 12v
5	1	33T36299	Fuse Assembly
6	1	35M12340B	12v Solenoid Valve
7	1	30T37954	Pressure Switch
9	1	34T36941	Wiring Pigtail
13	3	34M18250	Female Spade Connector
14	2	34M18009	Ring Terminal
15	12	37M18000	Electric Wire 12ft.
16	1	43T35867	Elbow, Pipe To JIC
19	1	44MB2252	Street Tee
NS	1	19T36623	Capscrew
NS	1	22T35140	Hex Nut
NS	1	21T37991	Lock Washer
Additional Parts Included with "P" SPECIAL FEATURE			
17	1	45M4R536	Lube Hose Ass'y
18	1	43T37385	Orifice Fitting
NS	1	43M05522	Elbow (F85 ONLY)
NS	2	43T37429	Fitting (185 ONLY)
For 24V Electric/Hydraulic Kit No. 48TK3930B, Substitute:			
		30T36453	Switch Ass'y 24v (Incl 1,2,4)
4	1	30T35712	Rocker Switch 24v
6	1	35M24340B	Solenoid Valve 24v
For connection to SPD1001A use 36TK4971 (12v) (sold separately)			
**	1	32MSR12V	Light Assembly
	1	36M01006	Face Plate W/ Light Access
	2	34M18187	Spade Terminal

CLUTCHSHIFT SERIES MANUAL AIR SHIFT INSTALLATION KIT 48TK4508 - 12V LIGHT

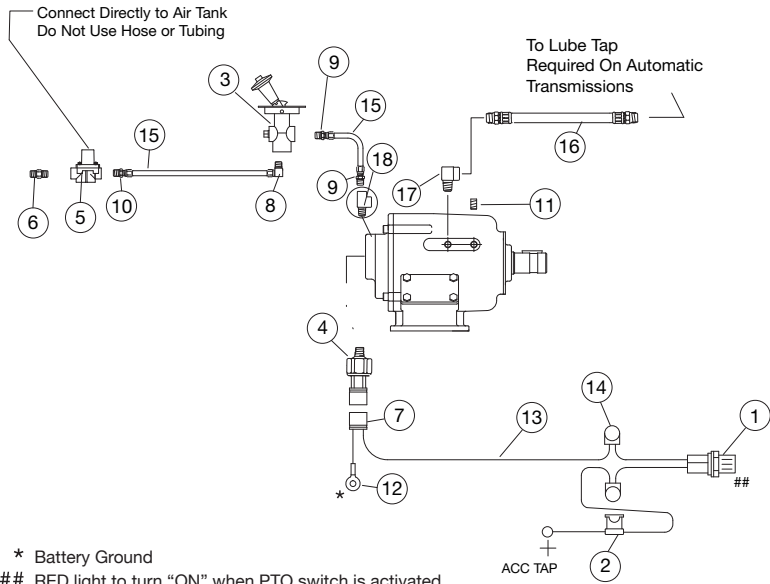

ITEM	QTY	PART NO.	DESCRIPTION
1	1	32M12001	Light Assembly 12v
2	1	33T36299	Fuse Assembly
3	1	35M18653	Air Valve
4	1	30T37954	Pressure Switch
5	1	31M15759	Press. Protection Valve
6	1	44MB2164	Pipe Nipple
7	1	34T36941	Wiring Pigtail
8	1	44MB6942	Fitting - Elbow
9	2	44MB6842	Male Connector
10	1	44MB6844	Male Connector
11	1	25T21684	Pipe Plug
12	2	34M18009	Ring Terminal
13	12	37M18000	Electric Wire 12ft.
14	3	34T36362	Closed End Crimp
15	1	45M44430	Air Tubing 30ft
18	1	44MB2252	Street Tee
N.S.	1	36MA1004	Dash Bracket
N.S.	1	36T38978	Face Plate
N.S.	1	36MK1007	Bolt Kit
Additional Parts Included with "P" SPECIAL FEATURE			
16	1	45M4R536	Lube Hose Ass'y
17	1	43T37385	Orifice Fitting
For 24V Electric/Air Kit No. 48TK4509 , Substitute:			
1	1	32M24001	Light Ass'y 24v

* Battery Ground

RED light to turn "ON" when PTO switch is activated.

CS 6S - M65 07 - E 1 B X

PTO TYPE

Clutch Shift (Standard Drag Brake) CS
Clutch Brake (Optional Shaft Brake) CB

MOUNTING

SAE 6 Bolt Std Mtg -6S
SAE 6 Bolt Non-Std. Mtg. -6D
SAE 6 Bolt Non Std Mtg Deep -6N
SAE 6 Bolt Std Mtg Metric -6M
SAE 6-Bolt Non Std Metric -6C
SAE 8 Bolt Std Mtg. -8S
SAE 8 bolt Std Metric -8M
SAE 8 Bolt Non Std Mtg -8D
SAE 8 Bolt Non Std Mtg Metric -8C

TRANSMISSION (INPUT GEAR OPTIONS)

Aisin -I84	Fuller -F84
Aisin -I85	Fuller -F85
Allison -A67	Fuller -F86
Allison -A69	Mack -M65
Clark/Fuller -C61	Mercedes -M83
Clark/Fuller -C70	Spicer -S73
Fuller -F10	Spicer -S71
Fuller -F11	Spicer -S60
Fuller -F61	Spicer -S70
Fuller -F63	Universal -S68
Fuller -F66	Universal -U60
Fuller -F70	Universal -U68

SPEED RATIO*

03 -- 0.33:1	07 -- 0.70:1
04 -- 0.44:1	09 -- 0.87:1
05 -- 0.47:1	12 -- 1.15:1
06 -- 0.56:1	14 -- 1.44:1 (8Bolt Only)

SPECIAL FEATURE

X - None
C - Pulse Gen./Pres Lube/SPD1001A
D - Pulse Gen/SPD1001A
P - Pressure Lube
R - Pulse Gen/No Press Lube
S - Pulse Gen/Pressure lube

OUTPUT TYPE

B - 1-1/4 Round 5/16 KW
C - 1410 Comp Flg
D - DIN 5462 (Euro)
G - Special
I - DIN 5462
K - SAE B 2&4 Bolt
P - SAE B-B 2&4 Bolt
Q - SAE A 2 Bolt
R - SAE A 2 Bolt
S - SAE B 2 Bolt
T - SAE A 2 Bolt
Z - SAE B 2&4 Bolt C shaft
2 - DIN Comp Flg
6 - SAE B 2 Bolt

ASSEMBLY ARRANGEMENT

1, 2, 3, or 4 See Below

SHIFTER TYPE

A — Manual Air	H — Electric/Hyd 12v
E — Electric/Air 12v	J — Electric/Hyd 24v
F — Electric/Air 24v 5/16	

*Not all combinations are available for input gear options.
Refer to application catalog or service parts list.

ARRANGEMENT

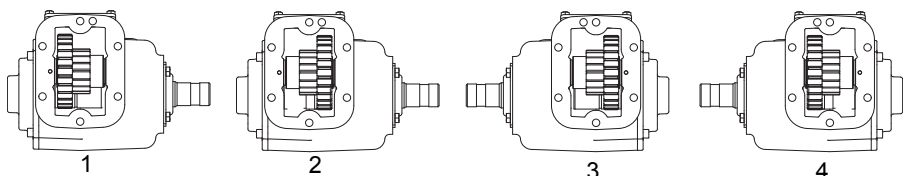

DIMENSIONS

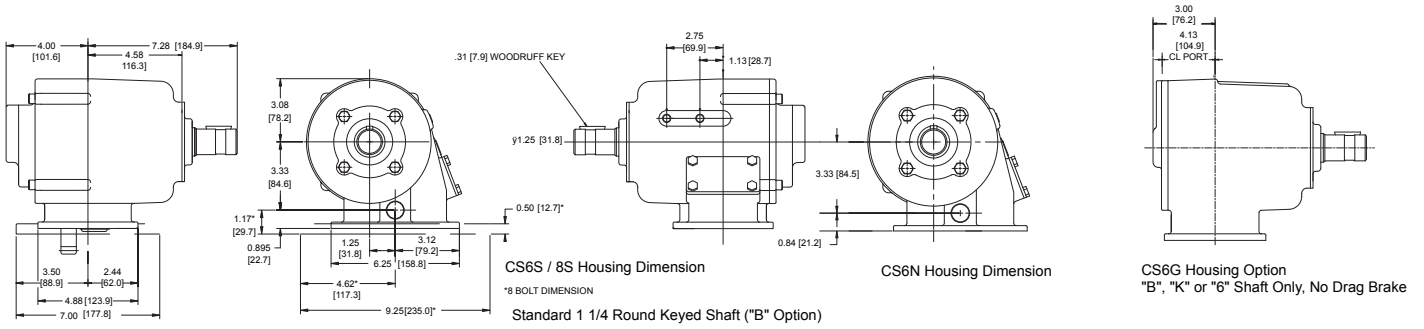

Special 7/8-13 Spline — "G" Option

Optional Pump Bolt Kit 19MK4717 - Sold Separately

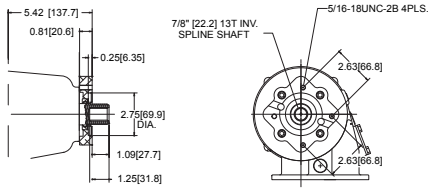

SAE "A" 2 Bolt

"Q" Option
 7/8 - 13 Spline
 "R" Option
 5/8 - 9 Spline
 "T" Option
 3/4 - 11 Spline

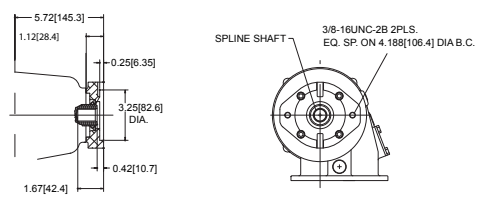

SAE "B" 2 & 4 Bolt 7/8-13 Spline — "K" Option

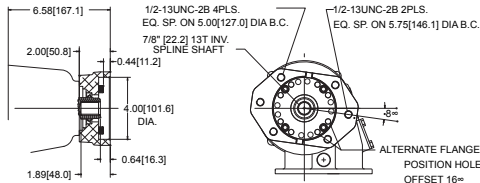

SAE "B" 2 Bolt 7/8-13 Spline — "S" Option

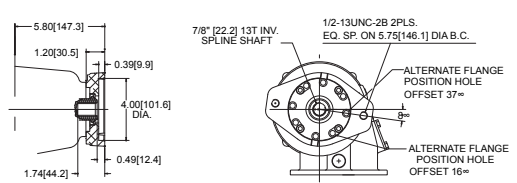

SAE "B-B" 2 & 4 Bolt 1"-15 Spline — "P" Option

Non-STD
 2 & 4 Bolt
 1-1/4" - 14 Spline
 "Z" Option

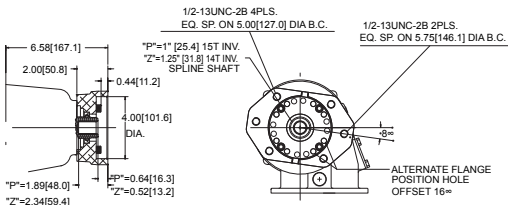

SAE "B" 2 Bolt 7/8-13 Spline — "6" Option

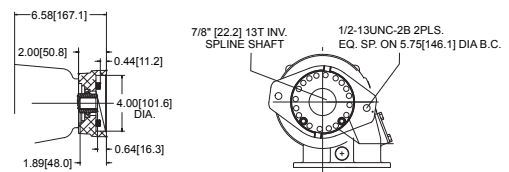

1410 Series Companion Flange — "C" Option

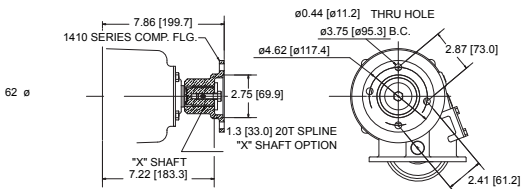

DIN 5462 4 Bolt A8x32x36 — "I" Option

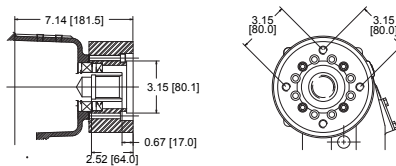

DIN 100 Companion Flange — "2" Option

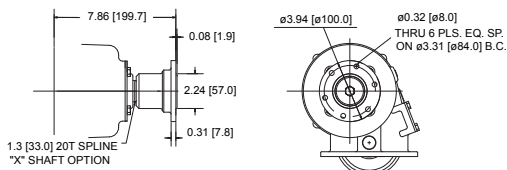

DIN 5462 4 Bolt A8x32x36 — "D" Option

Also (CS6G - "I" Option)

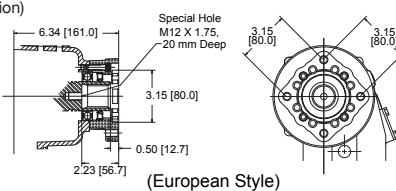

GASKET/REBUILD KITS

Refer to Item Number on page 3.

KEY: (Qty.) Item#

CS6-GSK GASKET KIT
Includes: (1)8, (1)9, (1)25, (2)26, (2)29, (1)35, (1)36,
(1)43,(1)13M35091, (1)13M35092

CS8-GSK GASKET KIT
Includes: (1)8, (1)9, (1)25, (2)26, (2)29, (1)35, (1)36,
(1)43, (1)13M35151, (1)13M35152

CS6-RBK-03 REBUILD KIT (Ratio 03 & 04)

CS6-RBK-05 REBUILD KIT (Ratio 05 - 14)

CS6-RBK-03-IZ REBUILD KIT (Ratio 03 & 04) Output I,Z,D

CS6-RBK-05-IZ REBUILD KIT (Ratio 05 - 14) Output I,Z,D
Includes: (2)2*, (4)4*, (2)5*, (1)8, (1)9, (2)10, (1)13,
(1)15, (2)16, (2)17, (1)18, (8)21,(7)22, (1)23, (1)25,
(2)26, (1)28, (2)29, (1)35, (1)36, (1)41, (2)46,
(1)13M35091, (1)13M35092

* use part number as required by ratio No.

CS6-RBK-A6805 Includes above with both input bearing options (item 2,4,5)

CS8-RBK-03 REBUILD KIT (Ratio 03 & 04)

CS8-RBK-05 REBUILD KIT (Ratio 05 - 14)

CS8-RBK-03-IZ REBUILD KIT (Ratio 03 & 04) Output I,Z,D

CS8-RBK-05-IZ REBUILD KIT (Ratio 05 - 14) Output I,Z,D
Includes: (2)2*, (4)4*, (2)5*, (1)8, (1)9, (2)10, (1)13,
(1)15, (2)16, (2)17, (1)18, (8)21,(7)22, (1)23, (1)25,
(2)26, (1)28, (2)29, (1)35, (1)36, (1)41, (2)46,
(1)13M35151, (1)13M35152

* use part number as required by ratio No.

Hi-Torque Brake Kits

CB6-GSK GASKET KIT
Includes: CS6-GSK above and items (2)7 and (1)8 from page 8.

CB8-GSK GASKET KIT
Includes: CS8-GSK above and items (2)7 and (1)8 from page 8.

CB6-RBK-03 REBUILD KIT (Ratio 03 & 04)
Includes: CS6-RBK-03 above and items (1)3, (4)4, (3)5, (2)7, (1)8, and (1)10 from page 8.

CB6-RBK-05 REBUILD KIT (Ratio 05 - 14)
Includes: CS6-RBK-05 above and items (1)3, (4)4, (3)5, (2)7, (1)8, and (1)10 from page 8.

CB8-RBK-03 REBUILD KIT (Ratio 03 & 04)
Includes: CS8-RBK-03 above and items (1)3, (4)4, (3)5, (2)7, (1)8, (1)10 and (1)12 from page 8.

CB8-RBK-05 REBUILD KIT (Ratio 05 - 14)
Includes: CS8-RBK-05 above and items (1)3, (4)4, (3)5, (2)7, (1)8, (1)10 and (1)12 from page 8.

MOUNTING KITS

6-BOLT & 8-BOLT

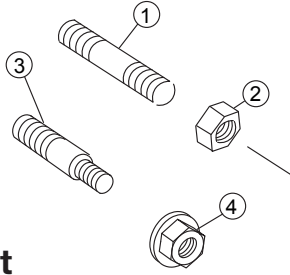

6-Bolt Mounting Kit

ITEM	QTY	PART NO.	DESCRIPTION
20TK4418 STD (CS6S, CS6D, CS6N-S71,S73)			
1	4	20M38150	Stud
2	4	22T39282	Nut
3	2	20T37032	Step Stud
4	2	22T37605	Lock Nut
N.S.	1	MC00-02	Instruction Card
20TK4359 Housing Code (CS6B, SH6C) Metric			
1	4	20M39040	Stud
2	4	22T39282	Nut
3	2	20T37952	Step Stud
4	2	22T37605	Lock Nut
N.S.	1	MC00-02	Instruction Card
20TK4360 Housing Code (CS6B-A6907) Metric			
1	4	20M39045	Stud
2	4	22T39282	Nut
3	2	20T38391	Step Stud
4	2	22T37605	Lock Nut
N.S.	1	MC00-02	Instruction Card
20TK4440 Housing Code (CS6B-184**) Metric			
1	4	20M38143	Stud
2	4	22T39282	Nut
3	2	20T38582	Step-Stud
4	2	22T37605	Lock Nut
N.S.	1	MC00-02	Instruction Card
20TK4046 Housing Code (CS6F-F84**) Metric			
1	4	20M39040	Stud
2	4	22T39282	Nut
3	2	20T37952	Step Stud
4	2	22T37605	Lock Nut
N.S.	1	13M51717	Loctite Gsk. Elim.
N.S.	1	MC99-06	Instruction Card

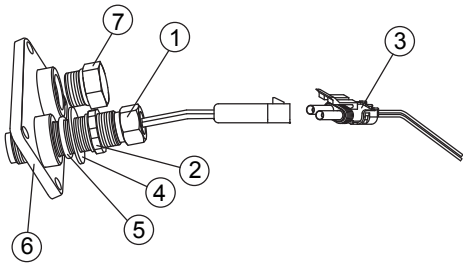

16TK3833 Speed Sensor Kit

SPECIAL OPTION C, D, R & S

ITEM	QTY	PART NO.	DESCRIPTION
1	1	31T35108	Mag Pickup
2	1	21T35109	Jam Nut
3	1	34MA1415	Wiring Harness
4	1	21T36099	Flat Washer
5	1	12T35774	O-ring
6	1	16T35523	Cover, Mag Pickup
7	1	25T35565	Plug

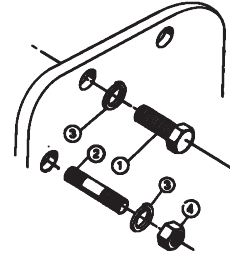

8-Bolt Mounting Kit

ITEM	QTY	PART NO.	DESCRIPTION
20MK8800 Housing Code (CS8S, CS8D)			
1	6	19M44138	Capscrew
2	2	20M44175	Stud
3	8	21ML4375	Lockwasher
4	2	22MX4420	Nut
20MKM801 (CS8B, CS8C) Metric			
2	8	20M47050	Stud
3	8	21ML4375	Lockwasher
4	8	22MX4420	Nut

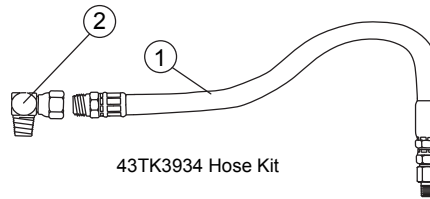

43TK3934 Hose Kit

Pressure Lube Hose Kit

ITEM	QTY	PART NO.	DESCRIPTION
1	1	45M4R536	Hose Assembly Std.
2	1	43M05522	Elbow

Delta Brand Coil Replacements

ITEM	QTY	PART NO.	DESCRIPTION
1	1	22T39429	Nut
2	1	35M12340DS	12V Coil
3*	1	N/A	Stem
4	1	12T39408	O-ring

* Not sold as a separate item.
DIM A = 1.89
DIM B = 1.77

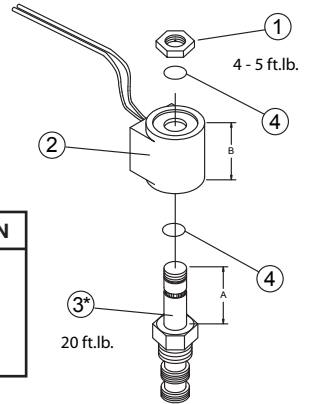

20 ft.lb.

PART NO.	DESCRIPTION
35T40087	12V Cartridge Assembly

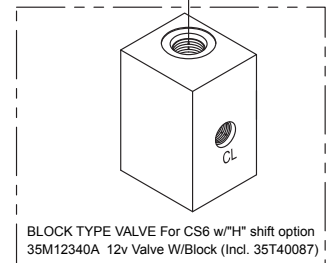

BLOCK TYPE VALVE For CS6 w/"H" shift option
35M12340A 12v Valve W/Block (Incl. 35T40087)

CSGB-200-125

EXPLODED VIEW & DIMENSIONS

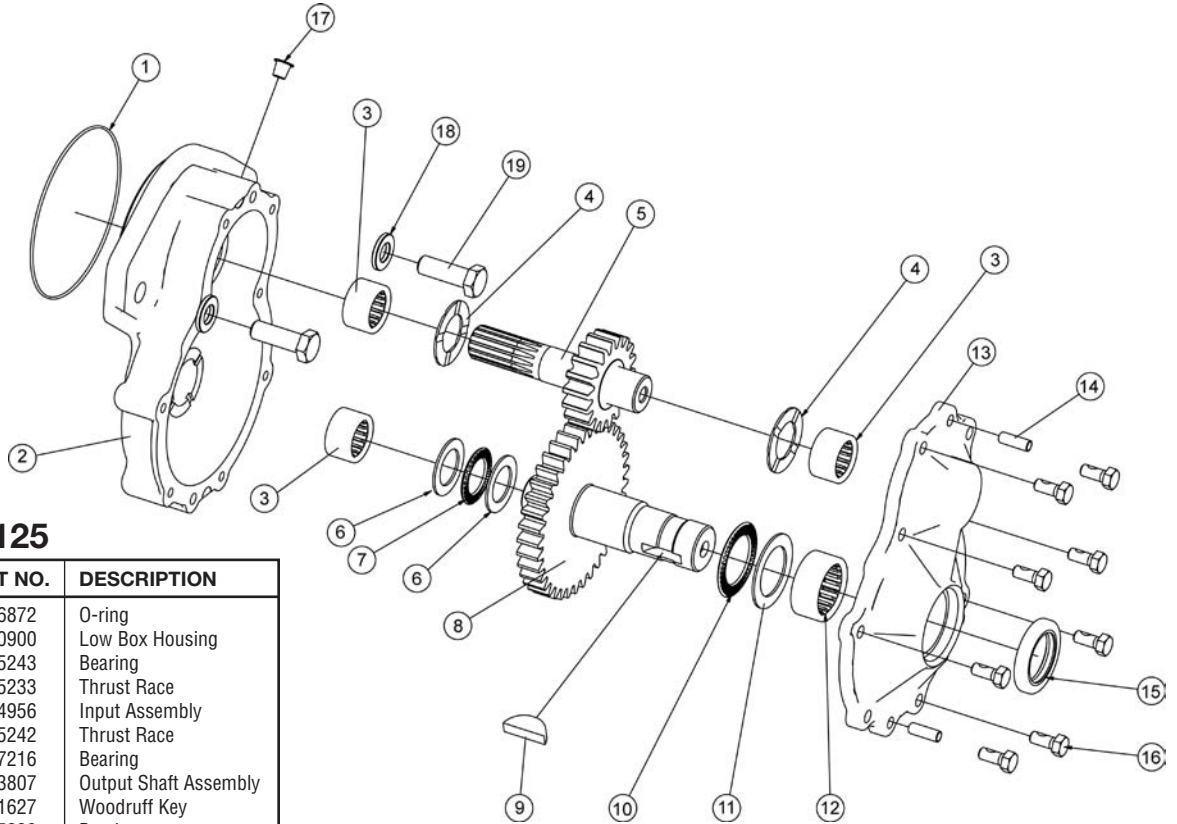

CSGB-200-125

ITEM	QTY	PART NO.	DESCRIPTION
1	1	12T36872	O-ring
2	1	01T40900	Low Box Housing
3	3	10T35243	Bearing
4	2	21T35233	Thrust Race
5	1	07TA4956	Input Assembly
6	2	21T35242	Thrust Race
7	1	10T27216	Bearing
8	1	06TA3807	Output Shaft Assembly
9	1	26T01627	Woodruff Key
10	1	10T35239	Bearing
11	1	21T35241	Thrust Race
12	1	10T35253	Bearing
13	1	15T35209	Low Box Cover
14	2	26T35232	Pin
15	1	11T37790	Oil Seal
16	8	19T32740	Screw, Hex Head
17	1	25T34029	Caplug
18	2	21T36002	Washer
19	2	19T35998	Cap screw

CS6B-A67**_**LP

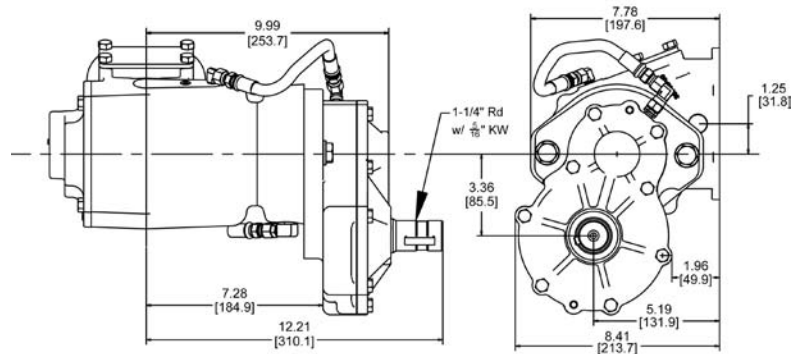
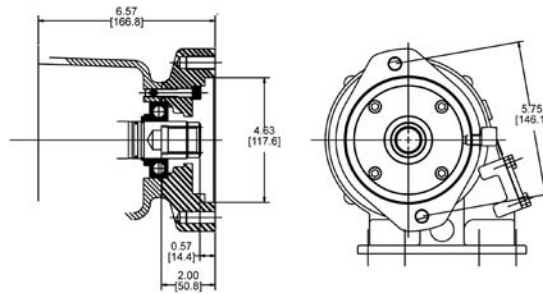
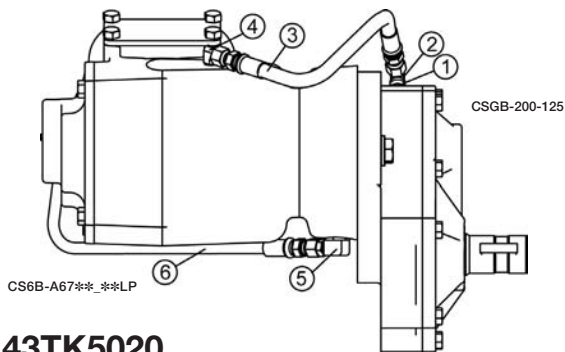

43TK5020 Lubrication Kit

ITEM	QTY	PART NO.	DESCRIPTION
1	1	43T37503	Straight JIC
2	1	43T36445	Elbow JIC
3	1	45T36308	Lube Hose
4	1	43T35867	Elbow JIC
5	*	43T37385	Orifice Elbow
6	*	43TK3934	Lubrication Hose Kit

*Supplied with PTO

The CS6 & CS8 PTOs include mounting kit, special shim/gasket, wiring harness, dash bracket kit, and installation instructions. Additional components may be necessary for proper installation. Please refer to application catalog and read and understand the instruction manual. This installation does not require any special tools. The PTO is available with an optional pulse generator pickup for use with the Muncie digital tachometer 38MK2000 (request MP92-04) or the SPD-1001A Muncie overspeed switch. The SPD-1001A is designed to control the engagement speed and provide overspeed protection of the PTO. Contact your Muncie Application Specialist for assistance with these options.



**Muncie[®]
Power
Products**

SP96-05 (Rev. 11-09) Printed in the U.S.A.
© Muncie Power Products, Inc. 2009

Muncie Power Products, Inc. *Member of the Interpump Hydraulics Group*
General Offices and Distribution Center • P.O. Box 548 • Muncie, IN 47308-0548
(765) 284-7721 • FAX (765) 284-6991 • E-mail info@munciepower.com
Web site <http://www.munciepower.com>

Drive Products, Exclusive Agents for Canada, *ISO Certified by an Accredited Registrar*

