

Bicycle Facility Design Guide



TABLE OF CONTENTS

Introduction

Standard Mid-Block Striping

Mid-Block bicycle lane striping - adjacent to parking.....	1
Mid-Block bicycle lane striping - adjacent to curb.....	2
Mid-Block bicycle lane striping - adjacent to alley or major driveway	3
Mid-Block bicycle lane striping - adjacent to a bus stop.....	4

Example Midblock Striping

30' Roadway - one way.....	5
31'-37' Roadway - one way.....	6
40' Roadway - one way.....	7
44' Roadway - one way.....	8
40'-42' Roadway - two way.....	9
44' Two way street striping.....	10
50' Two way street striping.....	11
60' Two way street striping.....	12



TABLE OF CONTENTS

Standard Near Side Intersection Striping

Bicycle lane striping - near side of intersection.....	13
Bicycle lane striping - adjacent to separate right turn lane.....	14
Bicycle lane striping - adjacent to near side bus stop.....	15
<i>Experimental</i> - Advanced bicycle box at signalized intersections.....	16

Typical Far Side Intersection Striping

Bicycle lane striping - far side of intersection.....	17
Bicycle lane striping - adjacent to far side bus stop.....	18

Example Intersections Striping

Intersection with one way street.....	19
Intersection with two way street.....	20
Three way intersection.....	21

Standard Markings

Bicycle facility symbols.....	22
<i>Experimental</i> - Shared lane symbol placement.....	23
Bicycle detection at actuated signalized intersections.....	24

TABLE OF CONTENTS

Standard Stormwater Grate

Bicycle safe stormwater grates..... 25

Standard Bicycle Rack Design

Bicycle rack designs..... 26

Bicycle parking rack placement..... 27

Standard Signs

Standard sign bike route..... 28

Right turn yield to bikes sign..... 29

Experimental - sign bicycles may use full lane..... 30

Experimental - sign look for bikes..... 31

Standard Trail Cross Section

Trail cross section..... 32

Standard Trail Intersection

Shared use path/roadway crossing..... 33

Shared use path crossing at a four way intersection..... 34

Shared use path crossing - midblock intersection..... 35

Midblock crossing median refuge..... 36

INTRODUCTION

In the year 2000, Mayor Anthony A. Williams called for making the District of Columbia the most bicycle friendly city in the nation. Since that time, DDOT has reestablished the Bicycle Program office, striped 28 miles of bicycle lanes, updated the City's Bicycle Master Plan, installed over 650 bicycle parking racks and 250 bicycle route signs, and initiated design and construction of several major trails.

Based on this experience, and on the experience of other cities and transportation agencies, DDOT has developed this Design Guide to assist with the planning, design, and implementation of bicycle facilities for the years to come.

The specifications are based on the Manual on Uniform Traffic Control Devices and the AASHTO Guide for the Development of Bicycle Facilities, together with input from DDOT staff.

The Design Guide includes specifications for bicycle lanes, bicycle-related signs, bicycle parking racks, and bicycle friendly sewer grates. The following questions and answers are intended to help with the use and interpretation of the Design Guide.

Who should use the Design Guide?

The guide is intended for DDOT staff undertaking resurfacing and reconstruction projects, and DDOT consultants preparing road reconstruction plans. It will also be useful for developers, planners, advocates and the public in general.

Where will bicycle lanes be installed?

Streets to receive bicycle lanes are identified in the 2005 Bicycle Master Plan, also available on the web site or at the Bicycle Program office. The blue dashes on the plan indicate bike lane streets. If you know about plans to resurface or reconstruct streets identified in the Bicycle Master Plan, please contact the Bicycle Program Office. Other streets also may be appropriate for bicycle lanes, so check with the Bicycle Program for any street work of 3 blocks or longer.

Where should bicycle route signs be installed?

The green bicycle route signs have been in use in the District since the 1970s. We have recently updated the sign (see Sheet 28) and the planned network of signed bicycle routes (see Bicycle Master Plan). Bicycle route signs should not necessarily be placed on bicycle lane streets. Bicycle route signs should be installed by the Traffic Operations Administration or by contractors as part of road reconstruction projects at the direction of the Bicycle Program Office.

INTRODUCTION

How wide is a bike lane?

All of the specifications, including width, are contained in this guide. The DDOT and AASHTO minimum is 5 feet next to a 7-foot parking lane. The preferred configuration is a 5-foot bike lane next to an 8 or 9-foot parking lane to minimize the risk of a cyclist being hit by a car door.

What is a bicycle-safe sewer grate?

A bicycle-safe grate is one in which the bars run perpendicular to the direction of traffic or that has a grid pattern so that bicycle tires can not get caught. If the bars are parallel to traffic, the bicycle wheel may get stuck in the grate, throwing the cyclist off the bike. Perpendicular bars do not necessarily mean lower flow. For areas with high flow, use the vane grate depicted in drawing number 25. Two of the three grates in the DDOT Standard Drawings are not bicycle safe. DDOT is working to correct this.

Where do I get additional copies of this Design Guide?

The design guide is available on the DDOT web site and www.ddot.dc.gov/bike or from the Bicycle Program Office at (202) 671-2730.

Can I add bicycle parking to a road project? Where should the racks be placed?

Yes, you can add bike parking to any project. The Bicycle Program Office can provide you with advice and specifications (see Sheets 26 and 27).

What if I see a mistake in the Design Guide?

This is DDOT's first bicycle design guide in 30 years. Staff in all DDOT administrations and staff at the Federal Highway Administration have reviewed the guide. However, as people use the guide over the years, necessary changes will inevitably arise. Please send your comments and questions for future versions to the Bicycle Program Office.



MID-BLOCK BICYCLE LANE STRIPING ADJACENT TO PARKING

TRAVEL LANE

Typical lane widths will vary between 10'-12'. The number of travel lanes will vary.

BICYCLE LANE LINE

6" Solid white line.

BICYCLE LANE

Bicycle lane is 5' minimum width.

BICYCLE LANE SYMBOL

Utilize 4'x8' preformed symbol. See detail 22.

PARKING LANE LINE

4" Solid white line.

PARKING LANE

See Chapter 46 in Design and Engineering Manual.

CURB AND GUTTER

Gutter is typically 1' to 2' in width of concrete or brick material. All lane width measurements are to face of curb.

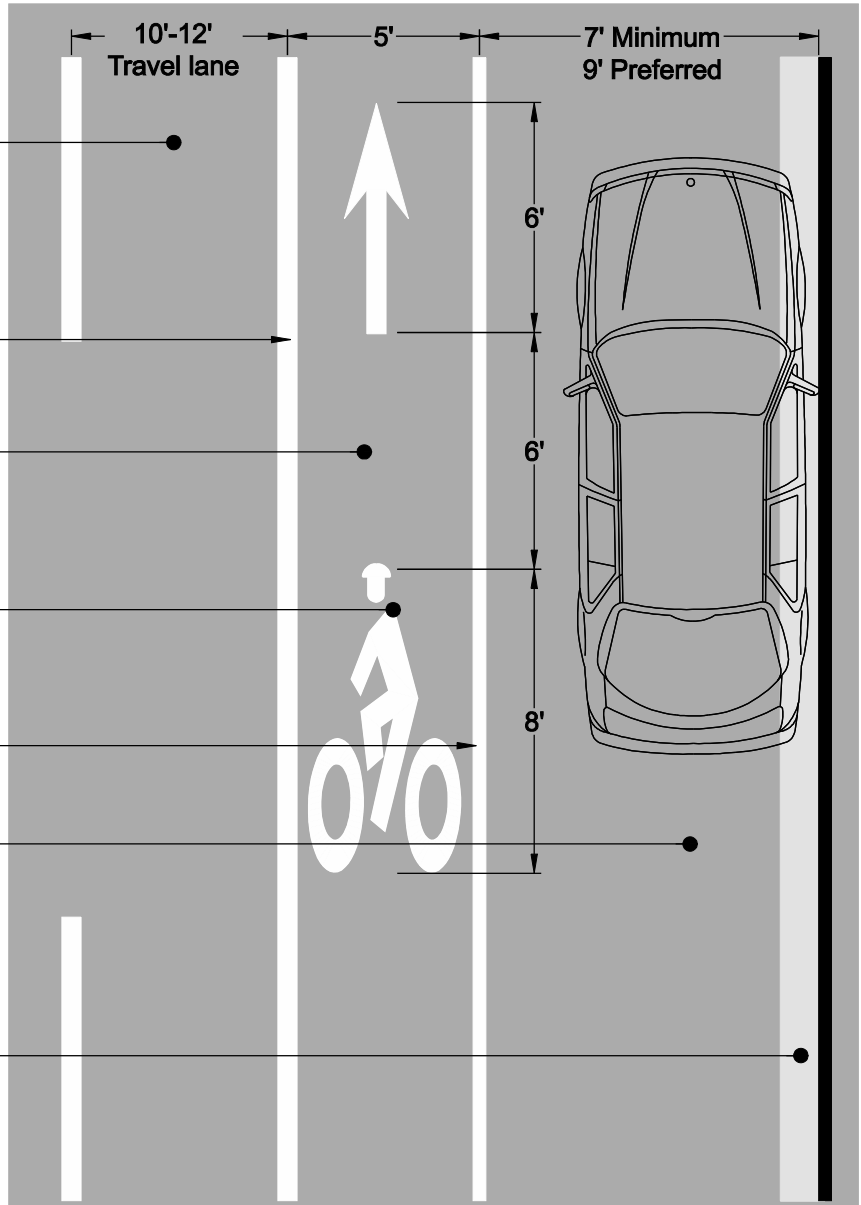

NOTES:

- STRIPING:** Utilize white thermoplastic on asphalt, high contrast tape on concrete.
- SYMBOLS ON PAVEMENT:** Utilize white preformed thermoplastic symbols.
- SYMBOLS ON CONCRETE:** Utilize high contrast tape symbols.
- PAVEMENT CONDITION:** The pavement should be inspected and damaged pavement should be replaced prior to striping of bicycle lanes.
- BICYCLE LANE SIGNAGE:** The placement of regulation or warning signs is governed by the MUTCD except where defined within this design guide.



District Department of Transportation

District Department of Transportation
Bicycle Facility Design Guide

REVISED:

Dec. 2006

SCALE:

1" = 5'

1

MID-BLOCK BICYCLE LANE STRIPING ADJACENT TO CURB

TRAVEL LANE

Typical lane widths will vary between 10'-12'.
Number of travel lanes will vary.

BICYCLE LANE LINE

6" Solid white line.

BICYCLE LANE

5' minimum width with including gutter pan.

RIDEABLE SURFACE

A rideable surface must be a 3' minimum smooth surface. The gutter pan does not count as a rideable surface. If the joint between the rideable surface and the gutter pan is not smooth, provide 4' minimum rideable surface to the left or right of the joint.

BICYCLE LANE SYMBOL

Utilize 4'x8' preformed bicycle symbol. See detail 22. Center symbol within lane.

CURB AND GUTTER

Gutter is typically 1' to 2' in width of concrete or brick material. Rideable surface measurements are to edge of gutter line. Bike lane measurements are to face of curb.

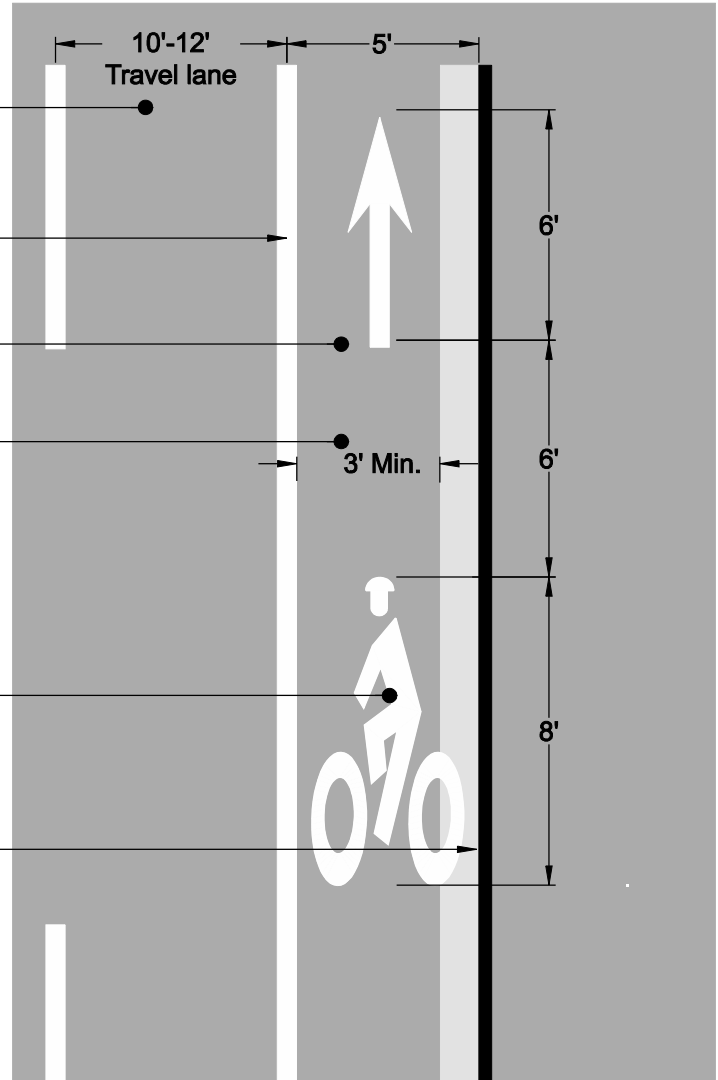

NOTES:

1. STRIPING: Utilize white thermoplastic on asphalt, high contrast tape on concrete.
2. SYMBOLS ON PAVEMENT: Utilize white thermoplastic preformed symbols.
3. SYMBOLS ON CONCRETE: Utilize high contrast tape symbols.
4. PAVEMENT CONDITION: The pavement should be inspected and damaged pavement should be replaced prior to striping of bicycle lanes.
5. BICYCLE LANE SIGNAGE: The placement of regulation or warning signs is governed by the MUTCD except where defined within this design guide.

MID-BLOCK BICYCLE LANE STRIPING ADJACENT TO ALLEY OR MAJOR DRIVEWAY

BICYCLE LANE ADJACENT TO PARKING

See detail 1.

BICYCLE LANE ADJACENT TO CURB

See detail 2.

BICYCLE LANE SYMBOL

Place near end of parking zone outside of turning vehicle wheel track.

PARKING ZONE LINE

Transverse line shall match no parking sign if provided. See Chapter 46 in Design and Engineering Manual for parking design criteria.

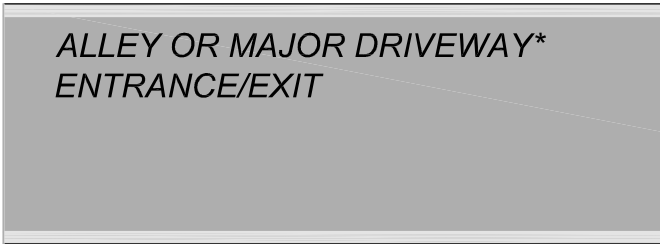

BICYCLE LANE GUIDELINES

2' solid line with 4' gap. Match width to solid parking and bicycle lane line striping.

PARKING ZONE LINE

Transverse line shall match no parking regulation sign if provided. See Chapter 46 in Design and Engineering Manual for parking design criteria.

BICYCLE LANE SYMBOL

Place near beginning of parking zone outside of turning vehicle wheel track.

NOTE:

A major driveway shall have a vehicular storage capacity greater than 5 vehicles.

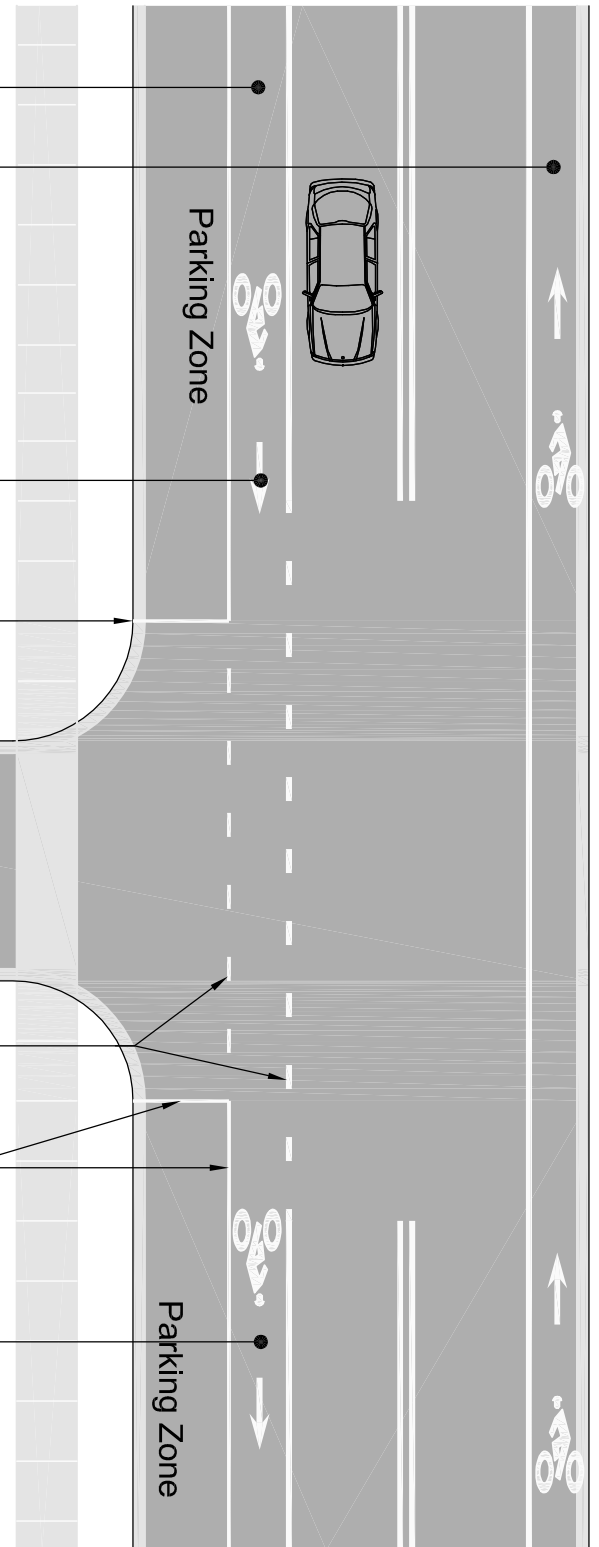

MID-BLOCK BICYCLE LANE STRIPING ADJACENT TO A BUS STOP

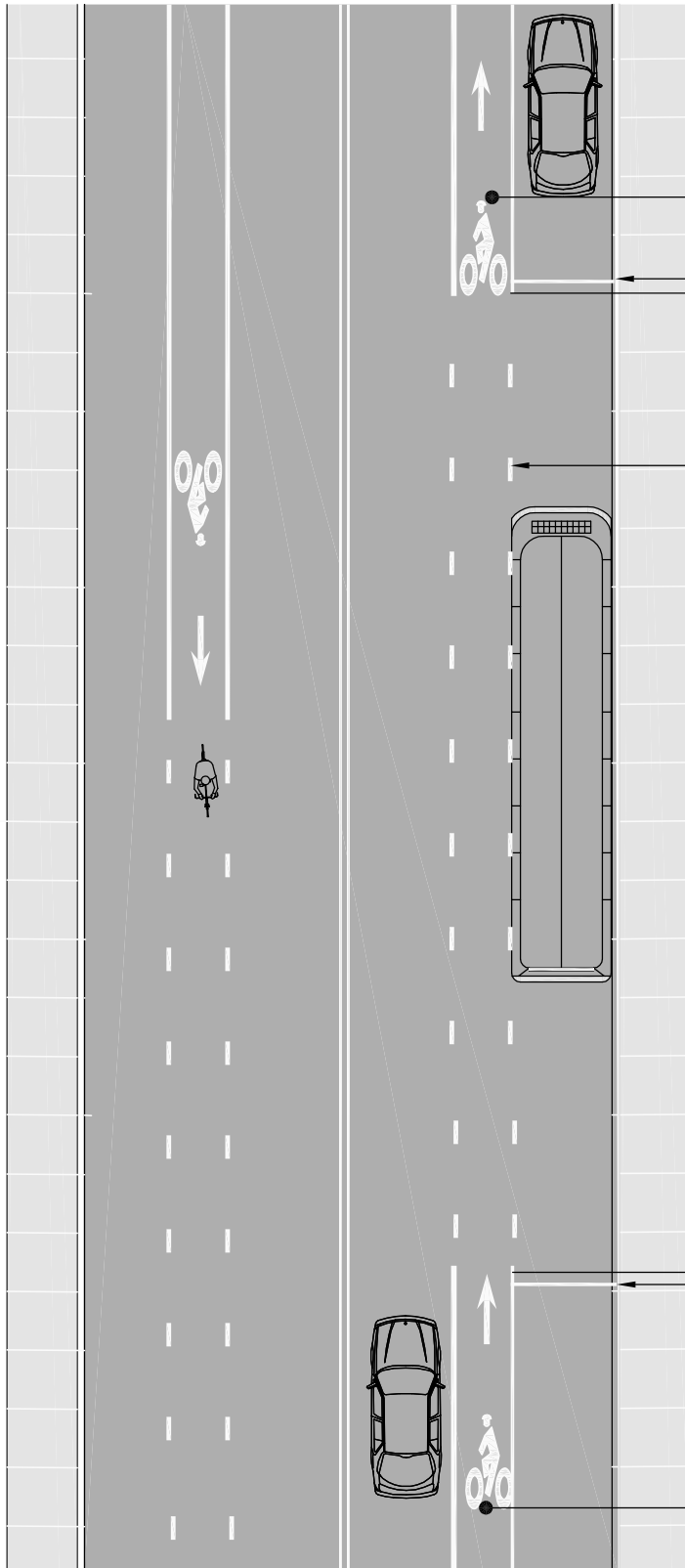

BICYCLE LANE SYMBOL

Place near the end of bus stop

PARKING ZONE LINE

Transverse line shall match no parking signs if provided. See Chapter 46 in Design and Engineering Manual for parking design criteria.

BICYCLE LANE GUIDELINES

2' Solid line with 4' gap. Match width to solid parking and bicycle lane line striping.

BUS STOP CLEARANCE (80'-150')

The length will be dependant upon the bus type and route requirements. Coordinate with DDOT and WMATA. This area is typically defined by a concrete pad with no parking signs on either side.

PARKING ZONE LINE

Transverse line shall match no parking signs if provided. See Chapter 46 in Design and Engineering Manual for parking design criteria.

BICYCLE LANE SYMBOL

Place near the beginning of bus stop

30' ROADWAY - ONE WAY

FULL TIME PARKING IN RIGHT LANE

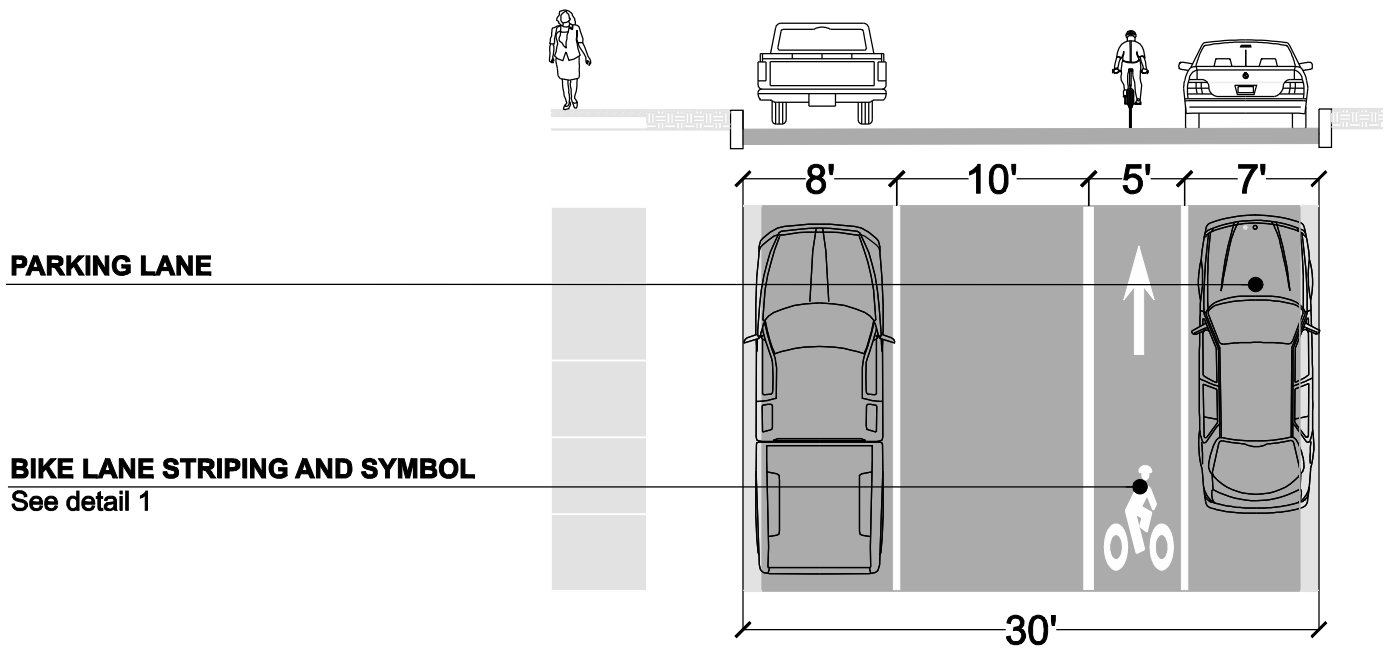

RUSH HOUR PARKING RESTRICTIONS IN RIGHT LANE

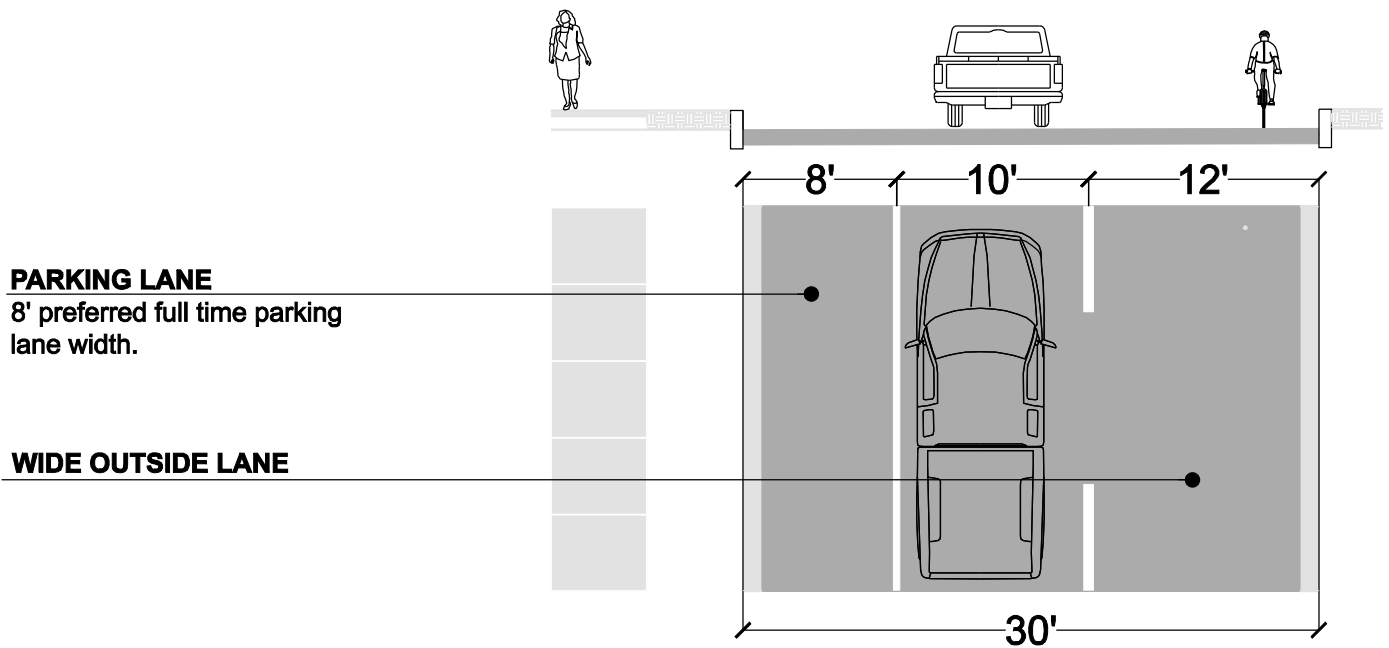

31'-37' ROADWAY - ONE WAY

FULL TIME PARKING IN RIGHT LANE

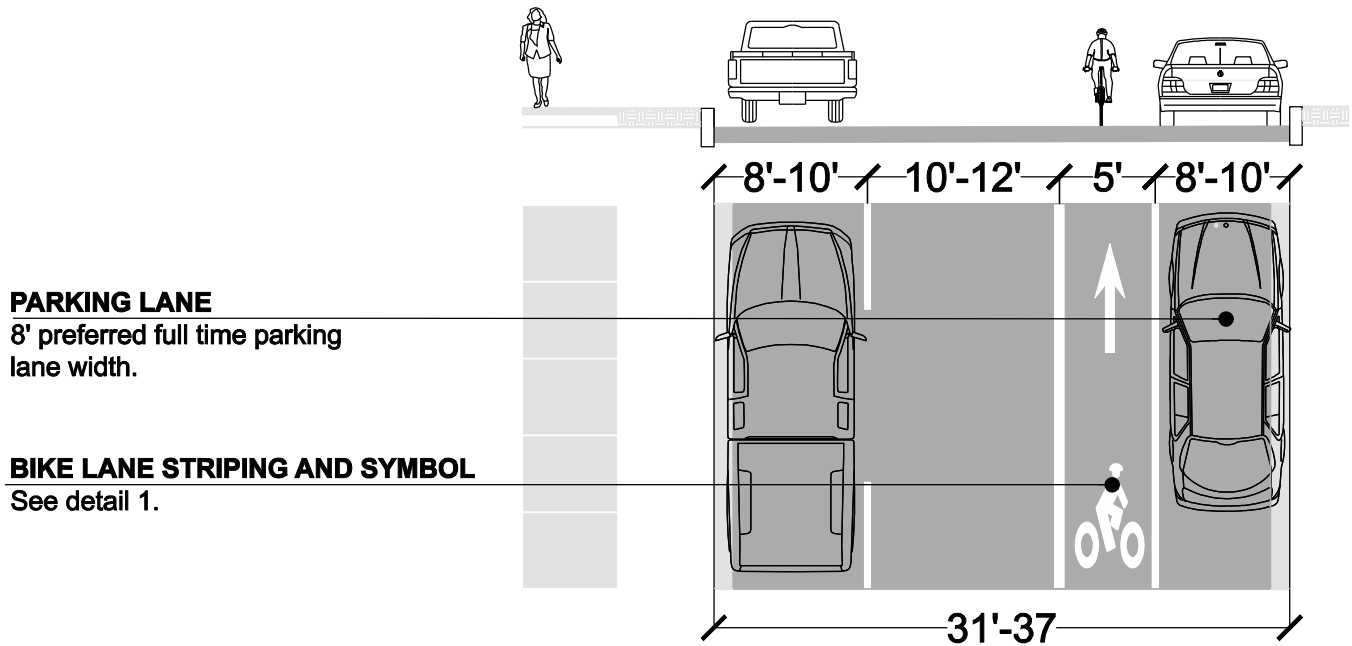

PARKING LANE

8' preferred full time parking lane width.

BIKE LANE STRIPING AND SYMBOL

See detail 1.

RUSH HOUR PARKING RESTRICTIONS IN RIGHT LANE

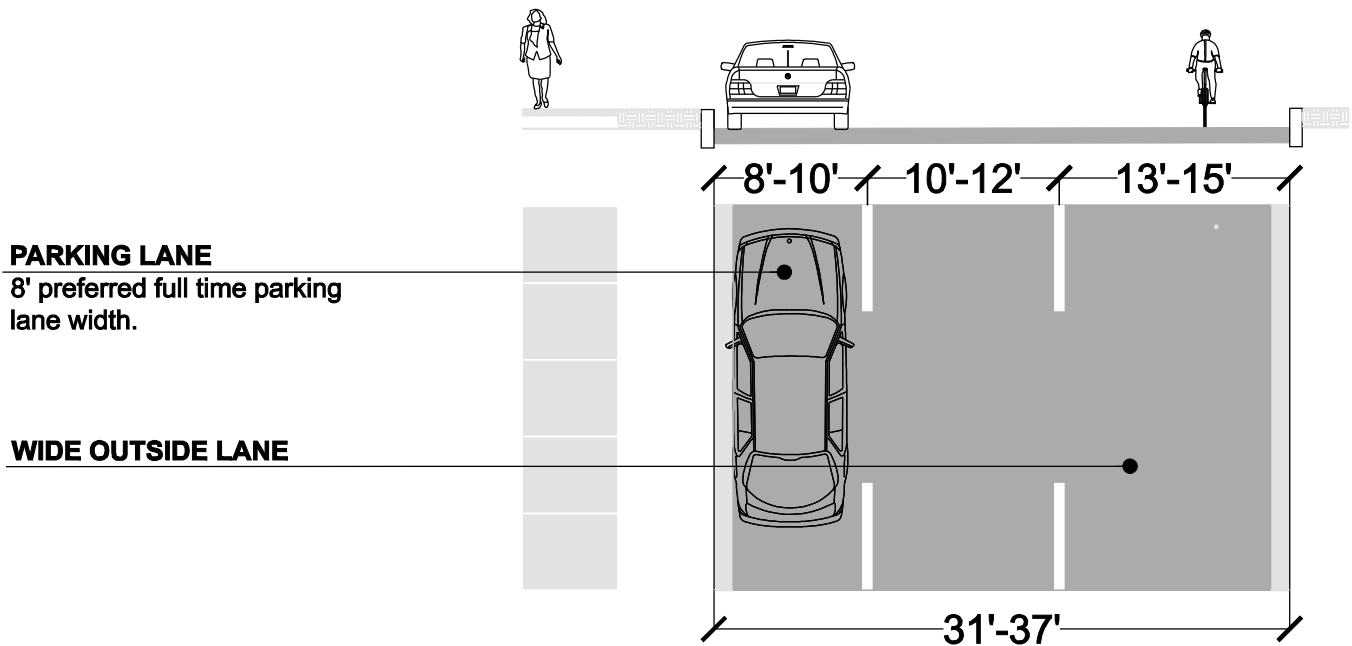

PARKING LANE

8' preferred full time parking lane width.

WIDE OUTSIDE LANE

40' ROADWAY - ONE WAY

FULL TIME PARKING IN RIGHT LANE

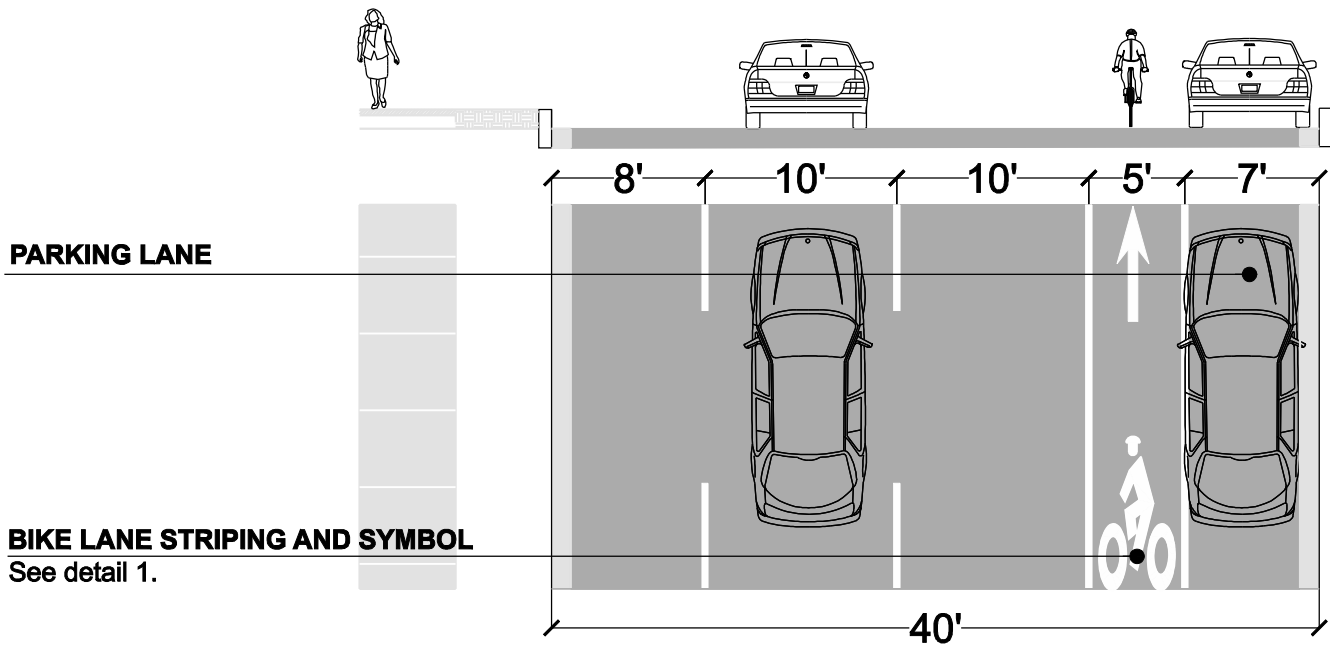

RUSH HOUR PARKING RESTRICTIONS IN RIGHT LANE

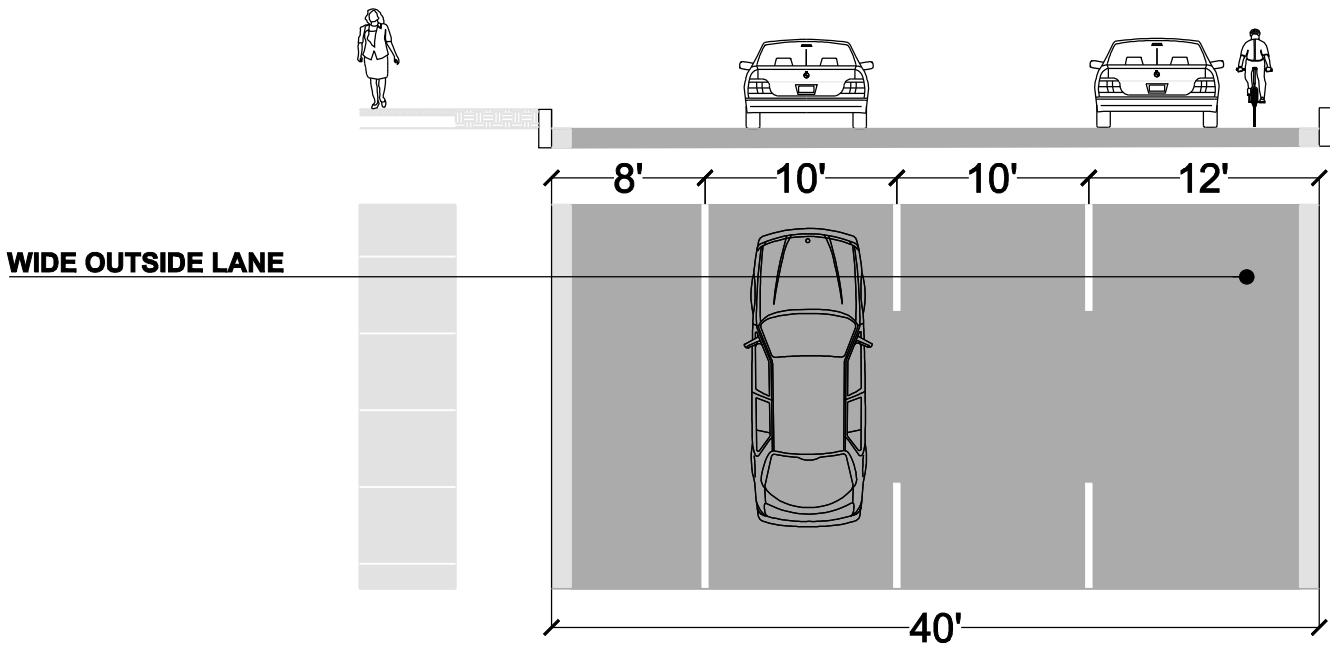

44' ROADWAY - ONE WAY

FULL TIME PARKING IN RIGHT LANE

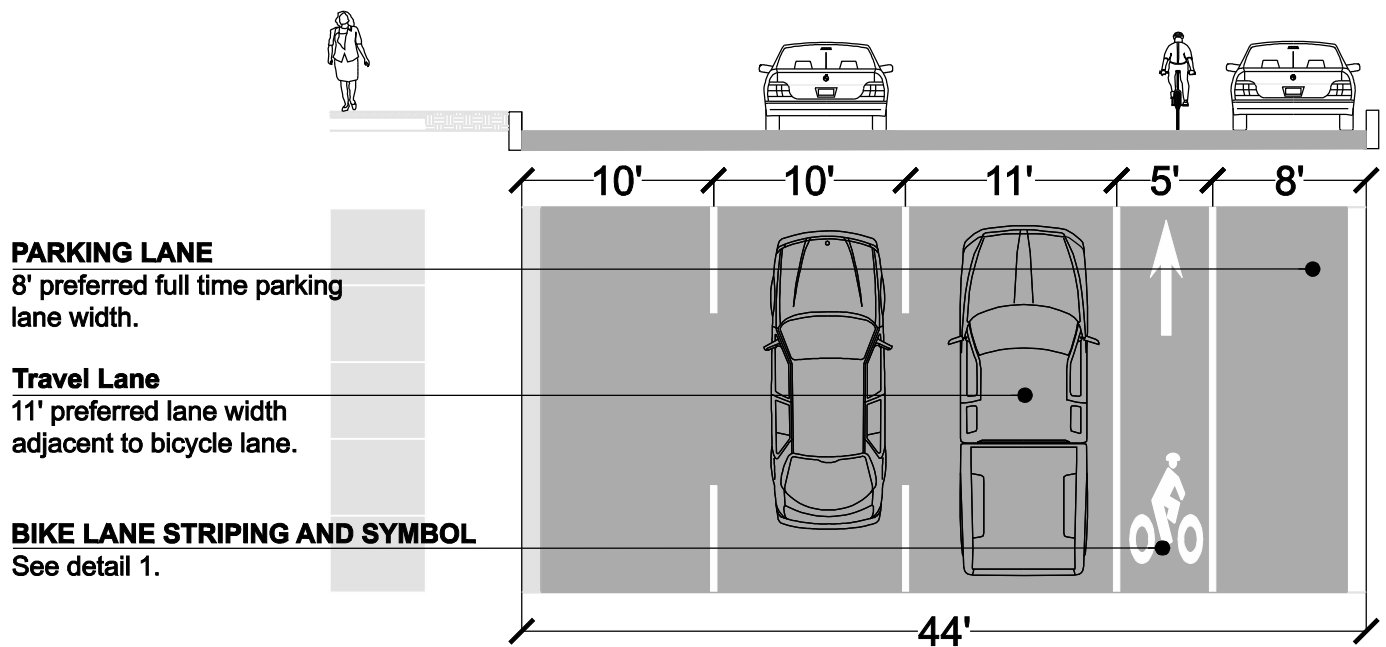

RUSH HOUR PARKING RESTRICTIONS IN RIGHT LANE

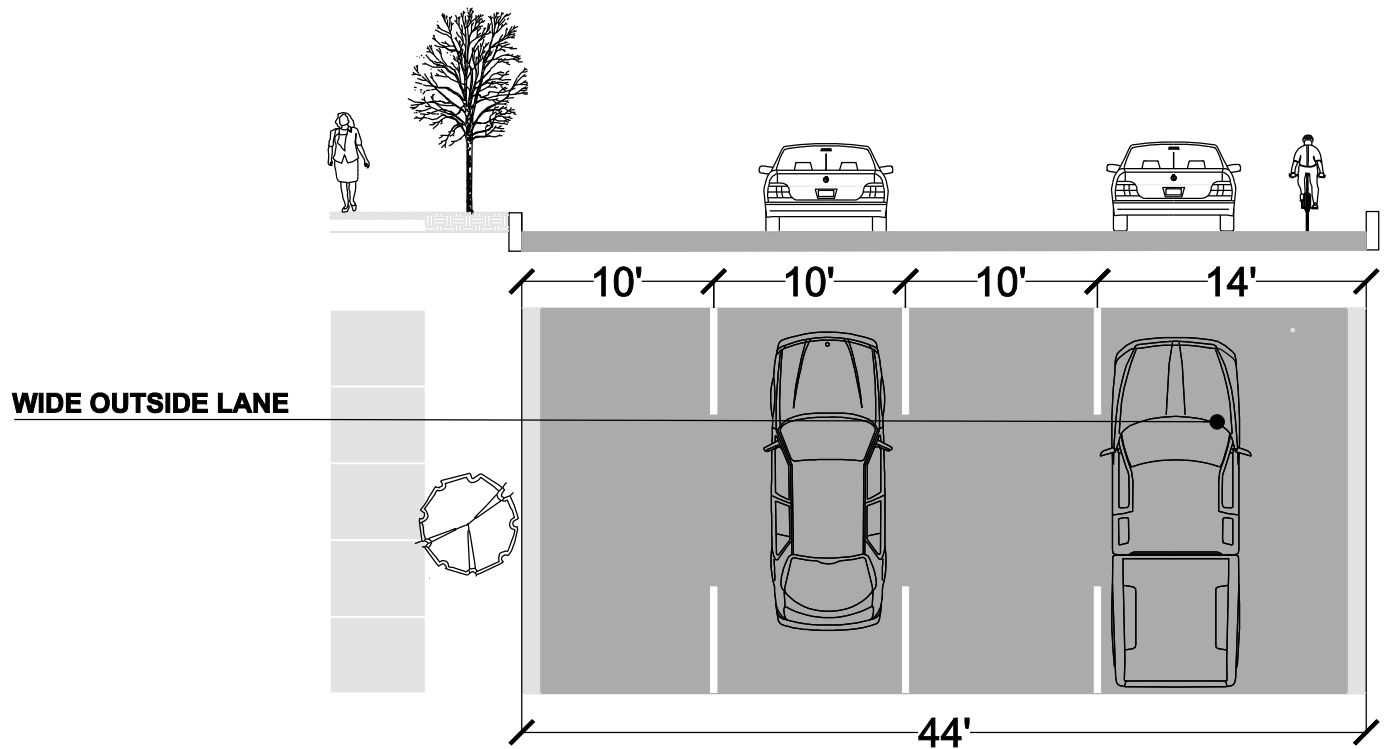

40'-42' ROADWAY - TWO WAY

FULL TIME PARKING IN RIGHT LANE

WIDE OUTSIDE LANE

13' preferred width. See detail 23.
Shared lane symbol optional.

WIDE OUTSIDE LANE

13' preferred width. See detail 23.
Shared lane symbol optional.

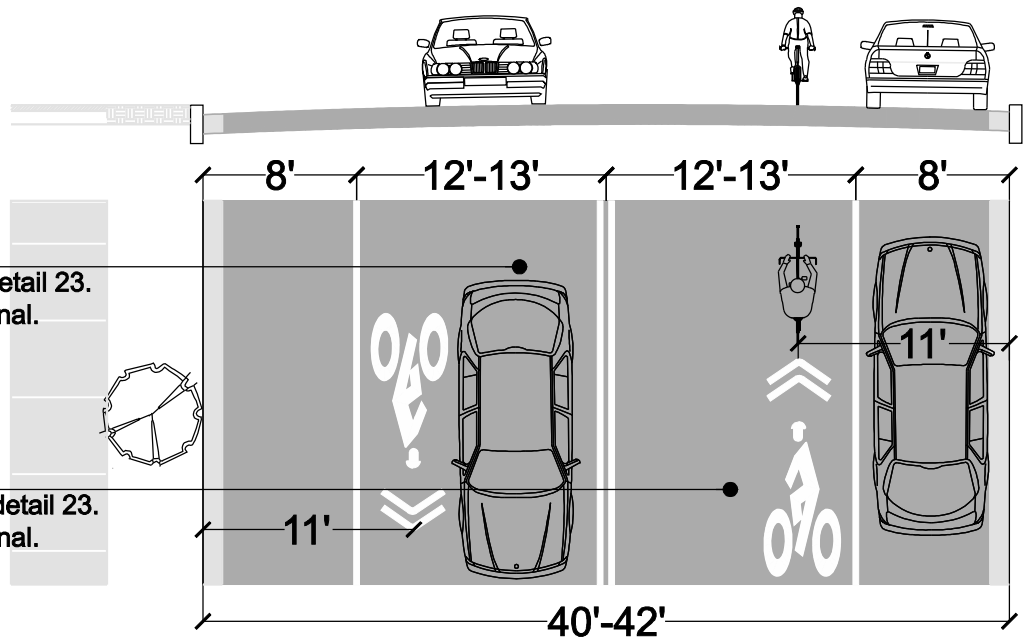

RUSH HOUR PARKING RESTRICTIONS IN RIGHT LANE

WIDE OUTSIDE LANE

13' preferred width.

WIDE OUTSIDE LANE

13' preferred width.

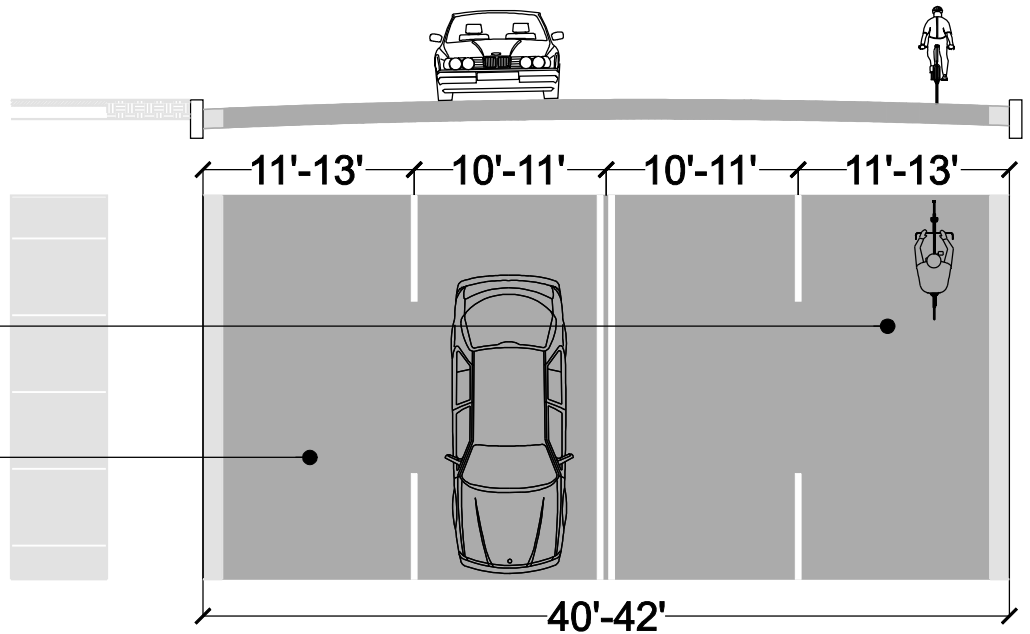

District Department of Transportation

District Department of Transportation
Bicycle Facility Design Guide

REVISED:

Dec. 2006

SCALE:

1" = 10'

9

44' TWO WAY STREET STRIPING

FULL TIME PARKING IN RIGHT LANE

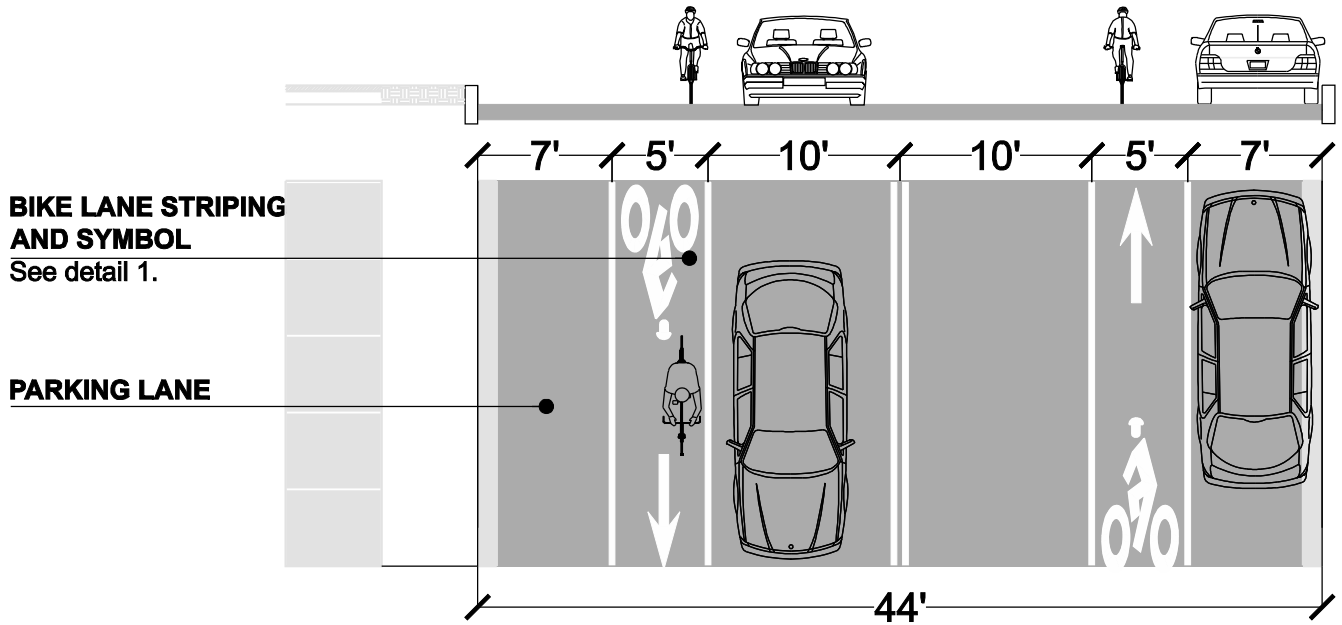

RUSH HOUR PARKING RESTRICTIONS IN RIGHT LANE

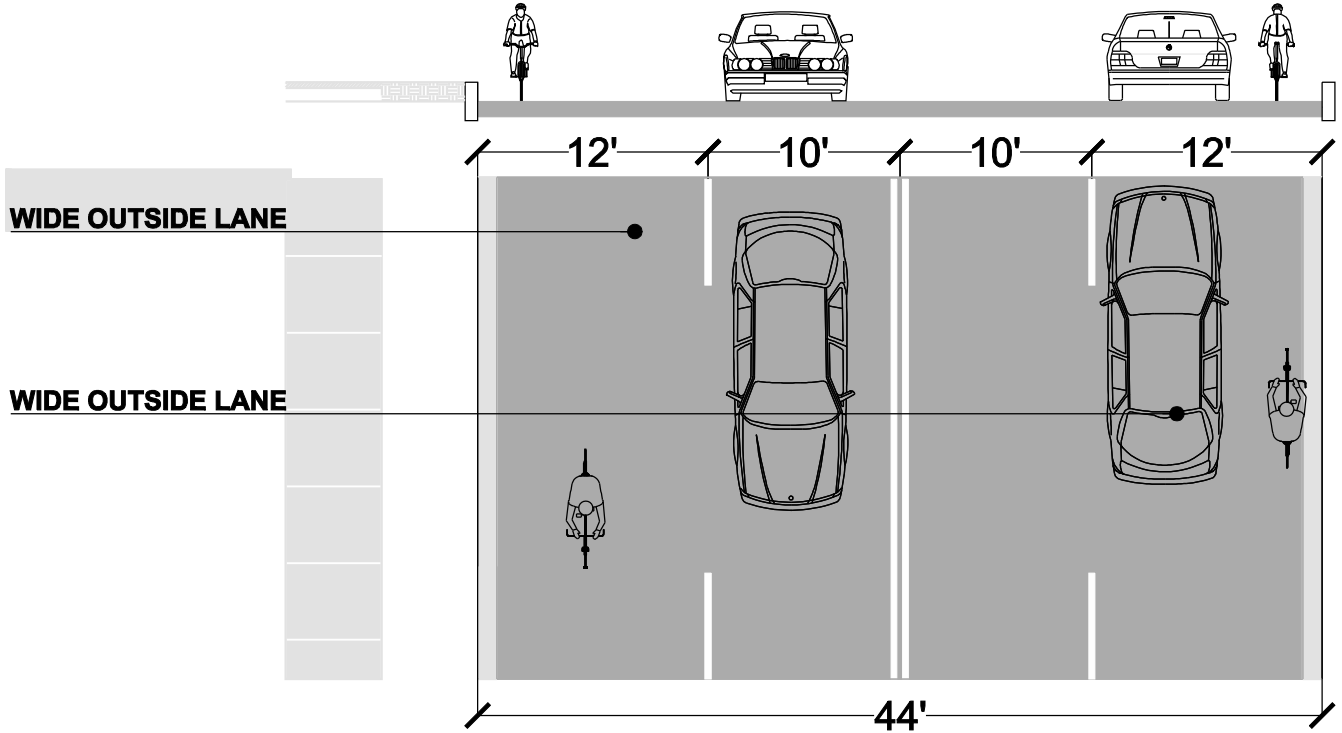

50' TWO WAY STREET STRIPING

FULL TIME PARKING IN RIGHT LANE

BIKE LANE STRIPING AND SYMBOL

See detail 1.

PARKING LANE

9' preferred parking lane width.

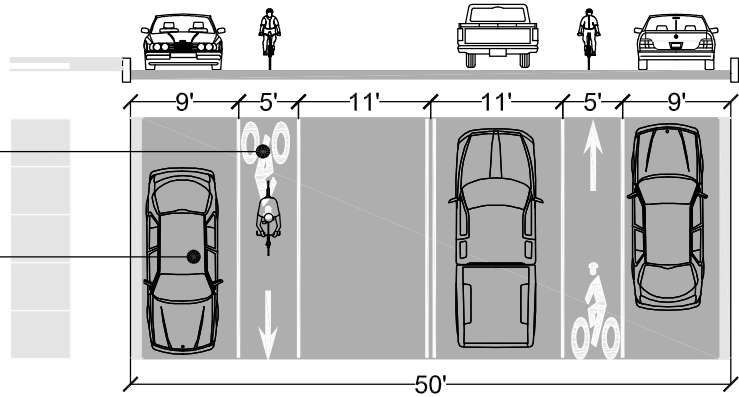

NO PARKING

BIKE LANE STRIPING AND SYMBOL

See detail 2.

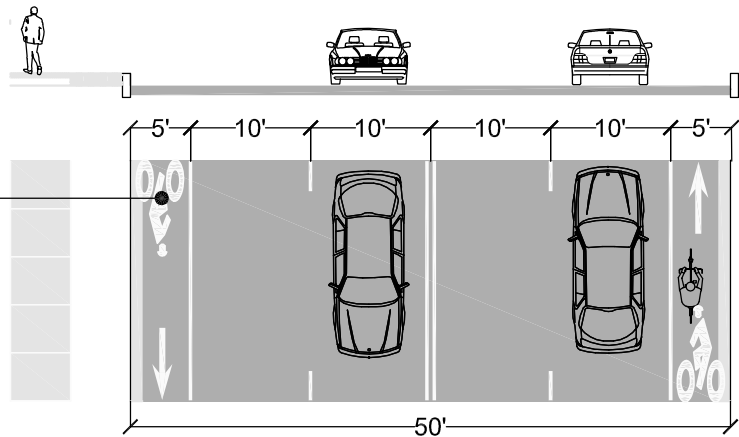

RUSH HOUR PARKING RESTRICTIONS IN RIGHT LANE

WIDE OUTSIDE LANE

14' preferred lane width.

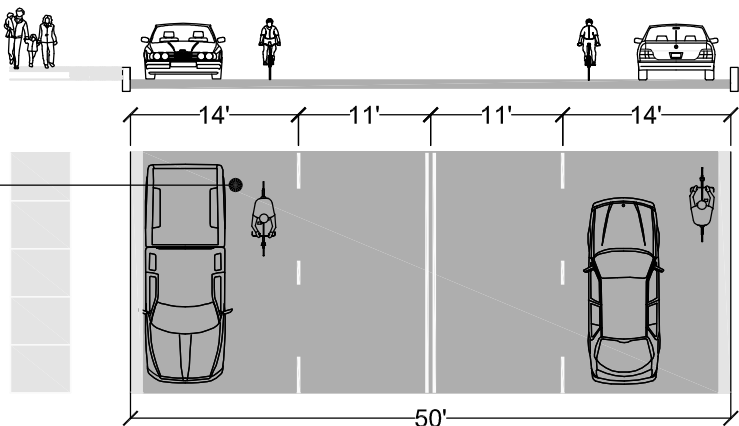

60' TWO WAY STREET STRIPING

FULL TIME PARKING IN RIGHT LANE WITH CENTER TURN LANE

PARKING LANE

9' preferred parking lane width.

BIKE LANE STRIPING AND SYMBOL

See detail 1.

CENTER TURN LANE AND/OR MEDIAN OR REVERSIBLE TRAVEL LANE

10' preferred turn lane width. 12' preferred reversible lane width.

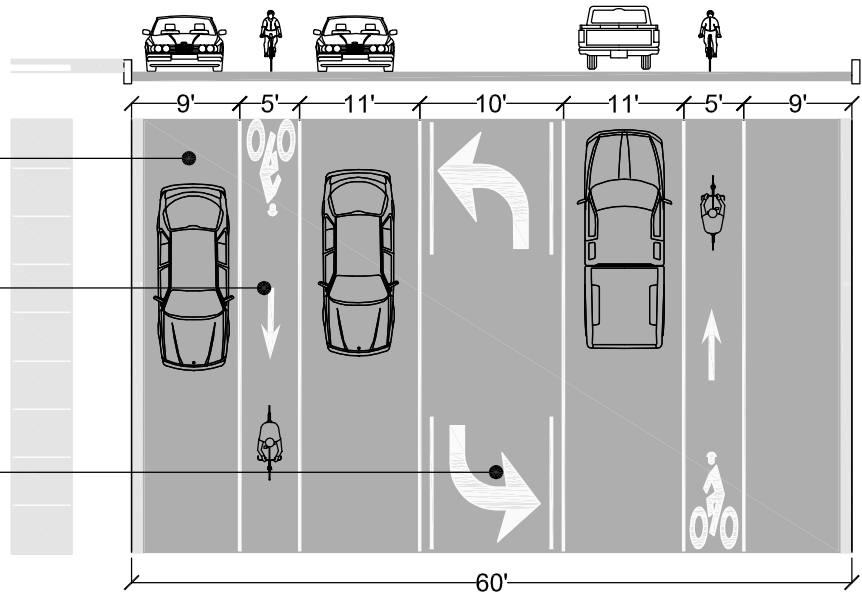

FULL TIME PARKING IN RIGHT LANE

PARKING LANE

8' preferred parking lane width.

WIDE OUTSIDE LANE

See detail 23.

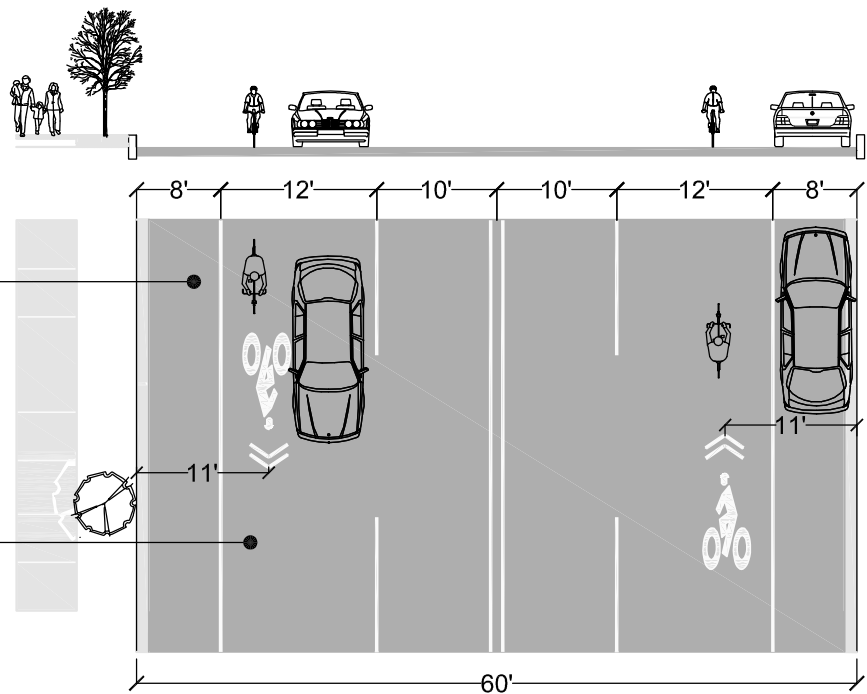

BICYCLE LANE STRIPING NEAR SIDE OF INTERSECTION

STOP LINE

See Chapter 43 in Design and Engineering Manual.

BICYCLE LANE GUIDELINE

Use dash line when vehicular right turns are allowed, otherwise utilize solid line.

6" wide, white, 30' minimum dashed bike lane stripe - 2' solid line with 4' gap.

BICYCLE DETECTION ZONE

See detail 24 for detector and pavement marking requirements.

BICYCLE LANE SYMBOL

See detail 22. Locate arrow 1' from stop line if no detector is present. See detail 24 if detector is present.

PARKING ZONE LINE

See note 3 below.

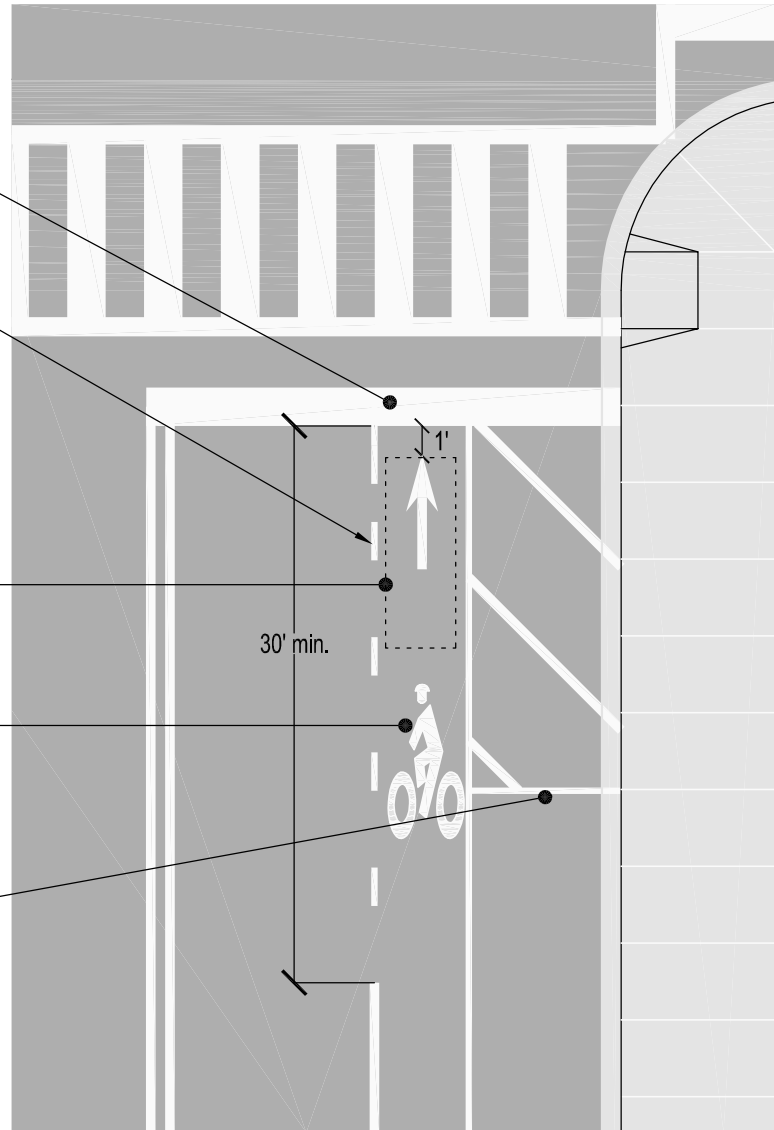

DETAIL A
SCALE 1" = 10'

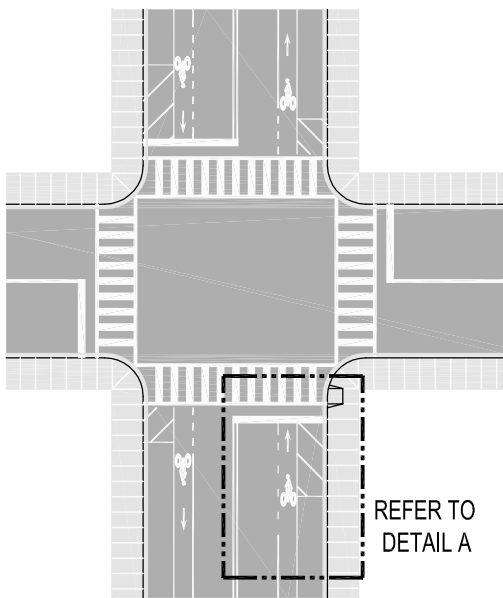

NOTE:

1. Bicycle lane dimensions adjacent to parking shown in detail 01.
2. Bicycle lane dimensions adjacent to curbing shown in detail 02.
3. Transverse line shall match no parking signs if provided. See Chapter 46 in Design and Engineering Manual for parking design criteria. Hatching the no parking zone is optional.

BICYCLE LANE STRIPING ADJACENT TO SEPARATE RIGHT TURN LANE

STOP LINE

See Chapter 43 in Design and Engineering Manual

BICYCLE LANE GUIDELINES

The width of the lane may vary between 3' - 6'. Do not utilize bicycle symbol for bicycle lanes that are < 5'.

6" White, dashed bike lane stripe - 2' solid line, 4' gap

PARKING ZONE LINE

See note 4 below.

BICYCLE LANE SYMBOL

See detail 22 for size; Locate symbol adjacent to beginning of right turn lane.

BICYCLE LANE LINE

6" Solid white line.

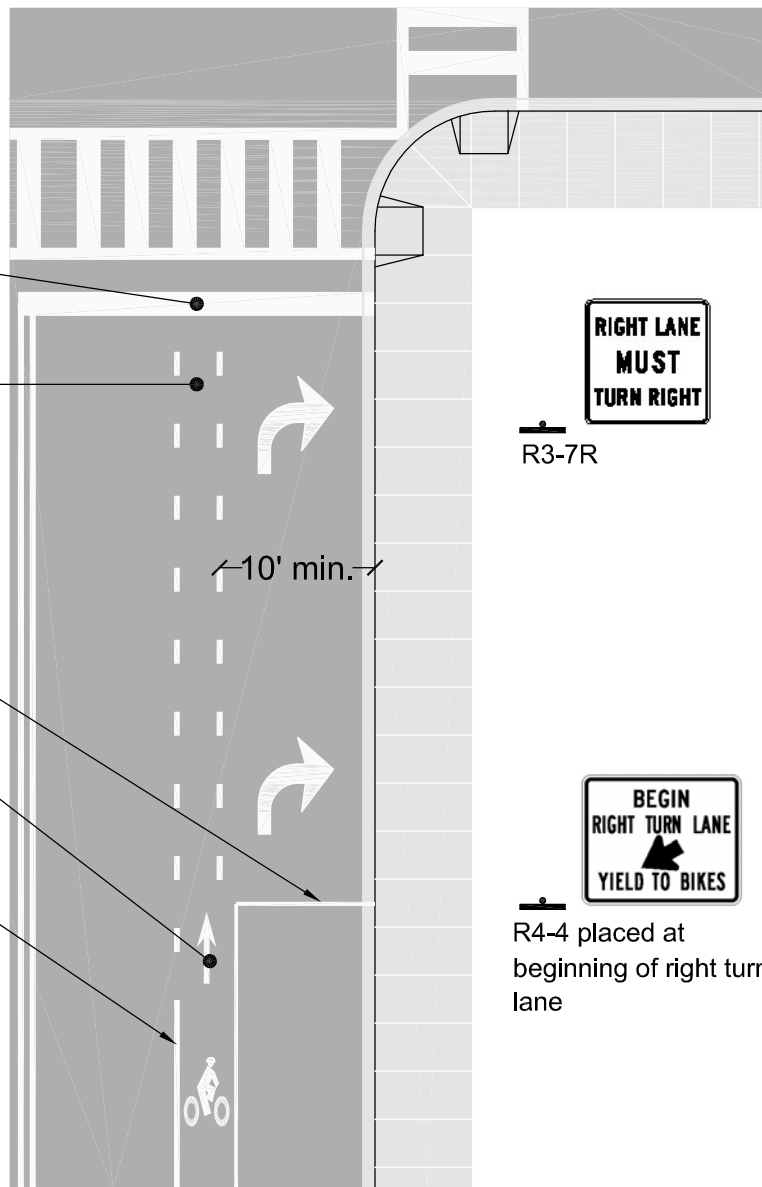
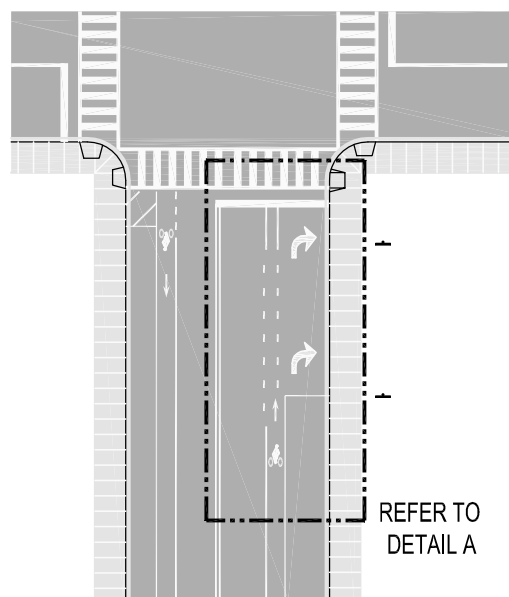

R3-7R



R4-4 placed at beginning of right turn lane

DETAIL A
SCALE 1" = 16'

NOTE:

1. Bicycle lane dimensions adjacent to parking shown in detail 1.
2. Bicycle lane dimensions adjacent to curbing shown in detail 2.
3. This treatment may also be utilized for near side bus stops detail 13.
4. Transverse line shall match no parking sign if provided. See Chapter 46 in Design and Engineering Manual for parking design criteria.



District Department of Transportation

District Department of Transportation
Bicycle Facility Design Guide

REVISED:

Dec. 2005

SCALE:

1" = 16'

14

BICYCLE LANE STRIPING ADJACENT TO NEAR SIDE BUS STOP

FAR SIDE BICYCLE LANE STRIPING

See detail 17

BICYCLE LANE GUIDELINES

6" wide , 80'-150' dashed line - 2' solid white line with 4' gap.

OPTION: vary width of bicycle lane between 3'-5' if right turns allowed from bus stop. See detail 14 for details on narrow bicycle lane.

BUS STOP CLEARANCE (80'-150')

The length will be dependant upon the bus type and route requirements. Coordinate with DDOT and WMATA. This area is typically defined by a concrete pad with a no parking signs on either side.

PARKING ZONE LINE

Transverse line shall match no parking sign if provided. See Chapter 46 in Design and Engineering Manual for parking design criteria.

BICYCLE LANE STRIPE

6" Solid White Line

BICYCLE LANE SYMBOL

Place at end of parking zone

PARKING STRIPE

4" Solid White

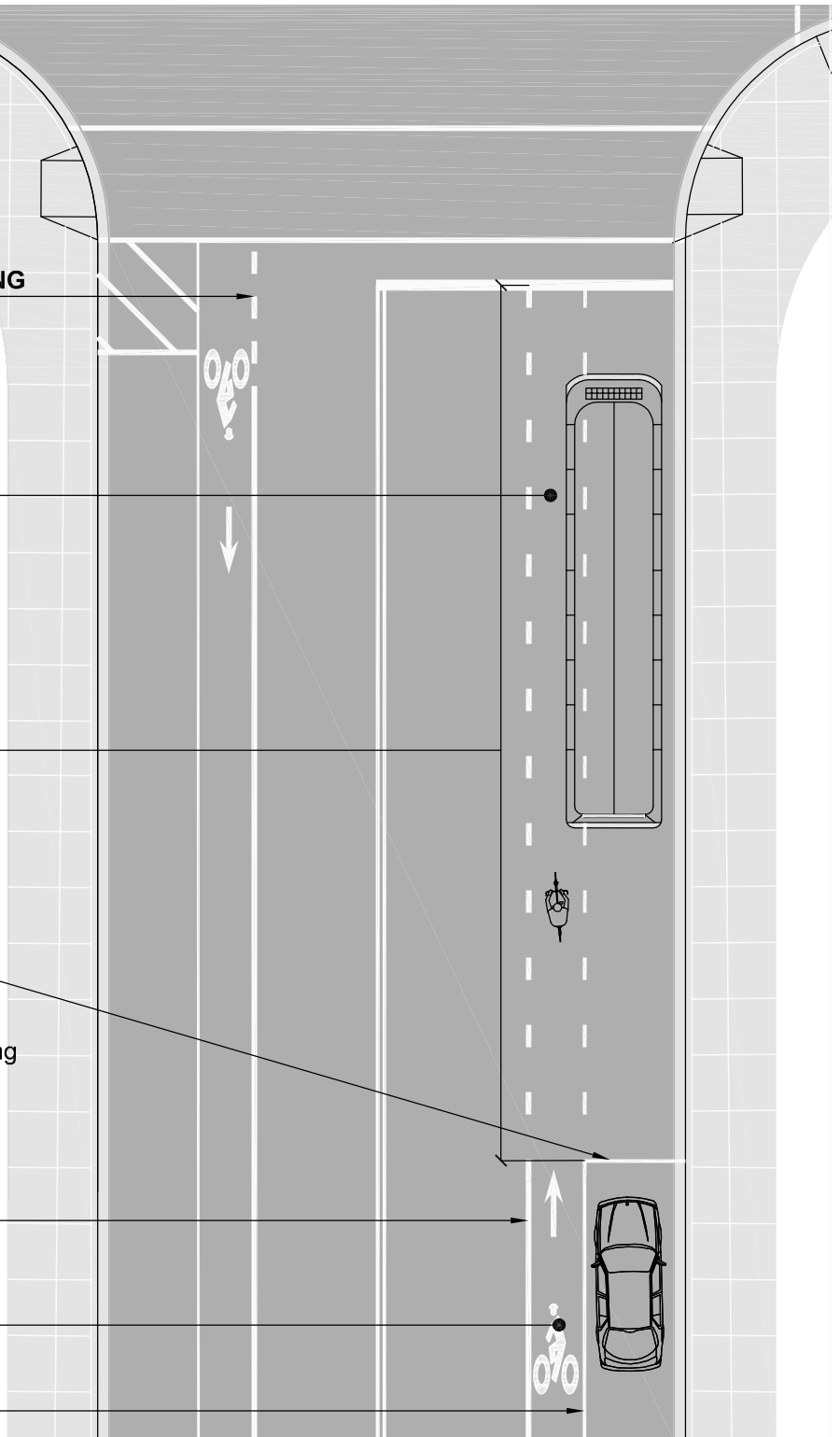

EXPERIMENTAL ADVANCED BICYCLE BOX AT SIGNALIZED INTERSECTIONS

ADVANCED BICYCLE BOX

Utilize where bicyclists are experiencing conflicts with vehicular turning movements.

BICYCLE LANE SYMBOL

Place multiple symbols without arrow to identify bicycle box.

STOP LINE

Place 8' -10' in advance of crosswalk with R10-6a sign. Break stop line at bicycle lane.

NO PARKING ZONE

PARKING LANE LINE

4" Solid white line. See note 2.

BICYCLE LANE SYMBOL

BICYCLE LANE LINE

6" Solid white line.

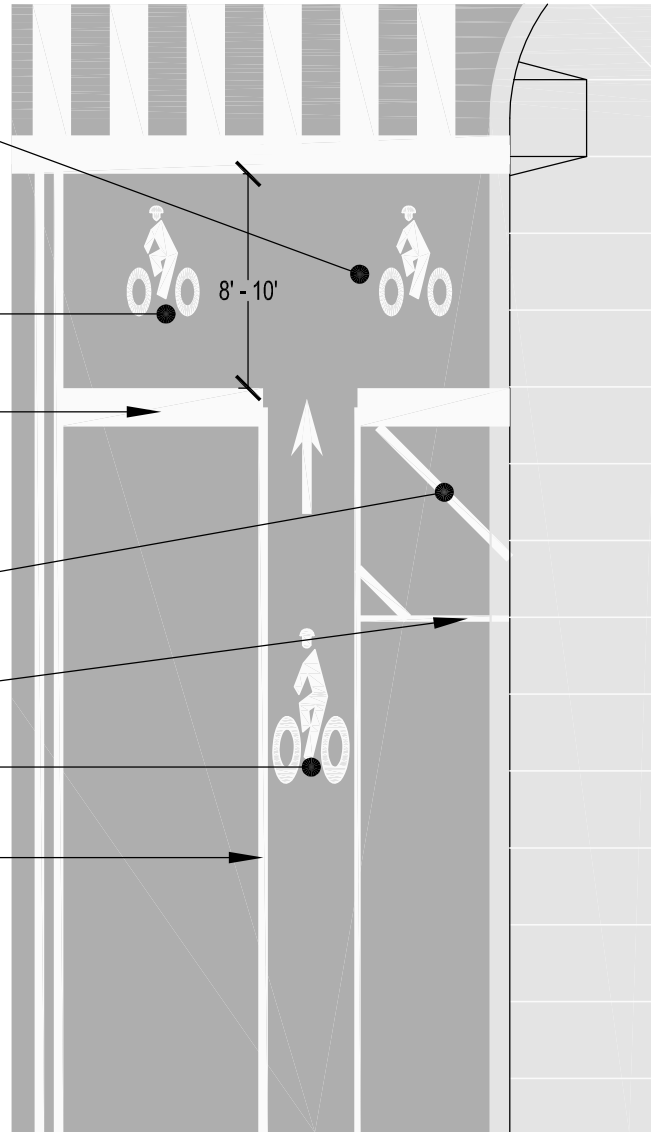

Modified R10-6a
Add "BIKES" to
top of sign

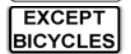

R10-6a with
"Except Bicycles"
subplate

DETAIL A
SCALE 1" = 10'

NOTE:

1. Vehicular right turns on red must not be allowed. Utilize signs to reinforce this. Utilize a modified R10-6a to mark bicycle stop point.
2. Transverse line shall match no parking sign if provided. See Chapter 46 in Design and Engineering Manual for parking design criteria. Hatching the no parking zone is optional.

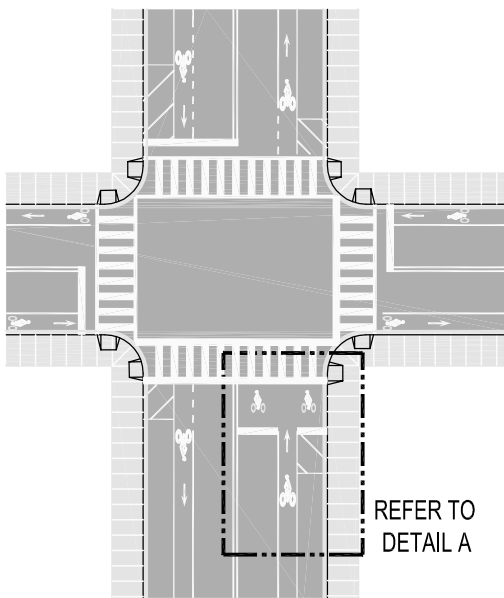

REFER TO
DETAIL A

BICYCLE LANE STRIPING FAR SIDE OF INTERSECTION

BICYCLE LANE LINE

6" Solid white line.

PARKING LANE LINE

4" Solid White Line

BICYCLE LANE SYMBOL

See detail 22. Place near beginning of parking zone outside of turning vehicle wheel track.

BICYCLE LANE GUIDELINE

Use when vehicular right turns allowed from adjacent roadway.

6" wide, white - 2' solid white line with 4' gap, typically 15'-25' length

NO PARKING ZONE

See note 3 below.

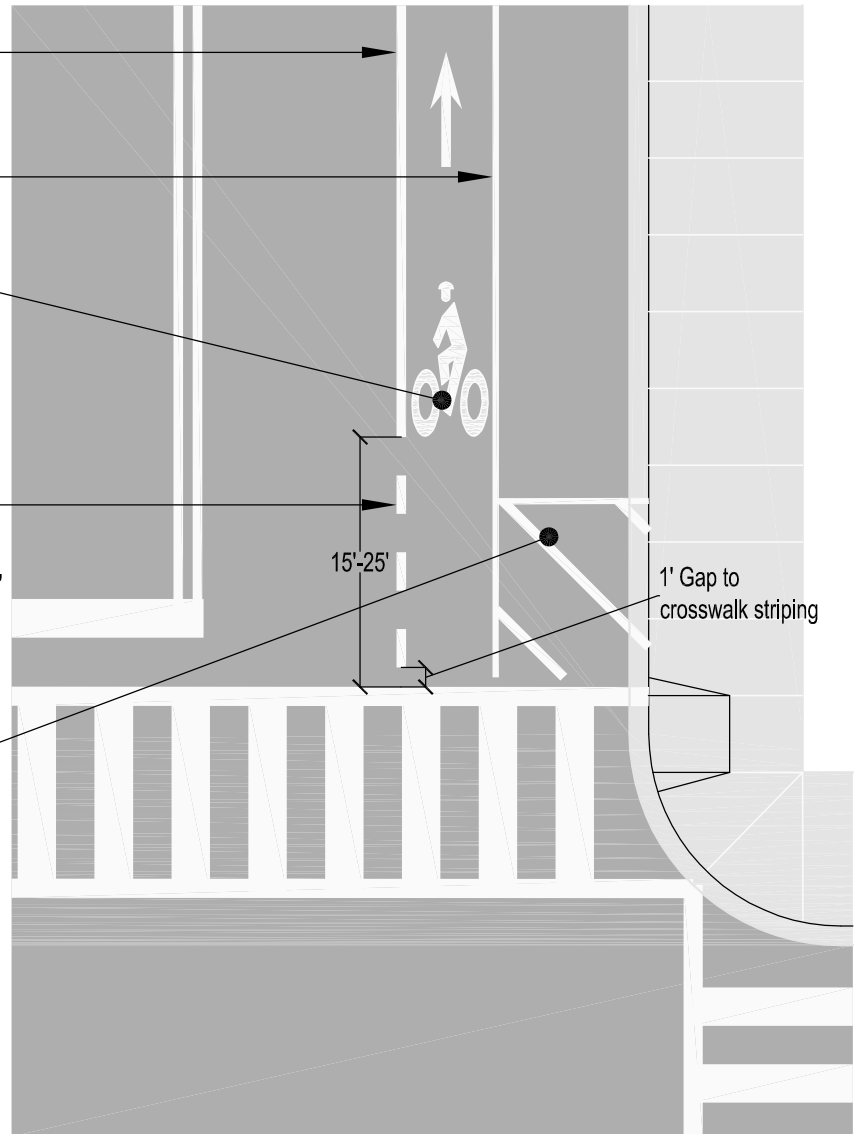

DETAIL A
SCALE 1" = 10'

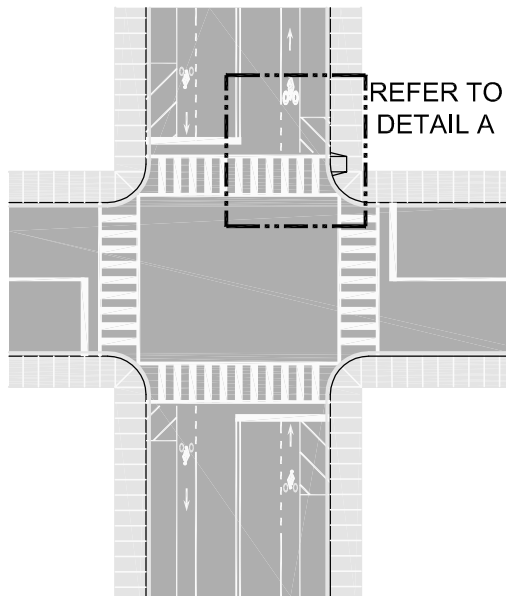

NOTE:

1. Bicycle lane dimensions adjacent to parking shown in detail 1.
2. Bicycle lane dimensions adjacent to curbing shown in detail 2.
3. Transverse line shall match no parking sign if provided. See Chapter 46 in Design and Engineering Manual for parking design criteria. Hatching the no parking zone is optional.

BICYCLE LANE STRIPING ADJACENT TO FAR SIDE BUS STOP

PARKING LANE LINE

4" Solid White Line

BICYCLE LANE STRIPE

6" Solid White Line

BICYCLE LANE SYMBOL

Place near start of parking zone or end of bus stop

PARKING ZONE LINE

Transverse line shall match no parking signs if provided. See Chapter 46 in Design and Engineering Manual for parking design criteria.

BIKE LANE GUIDELINES

6" wide , 80'-150' dashed line - 2' solid white line with 4' gap.

BUS STOP CLEARANCE (80'-150')

The length will be dependant upon the bus type and route requirements. Coordinate with DDOT and WMATA. This area is typically defined by a concrete pad with no parking signs on either side.

Near Side Bicycle Lane Striping

See detail 13

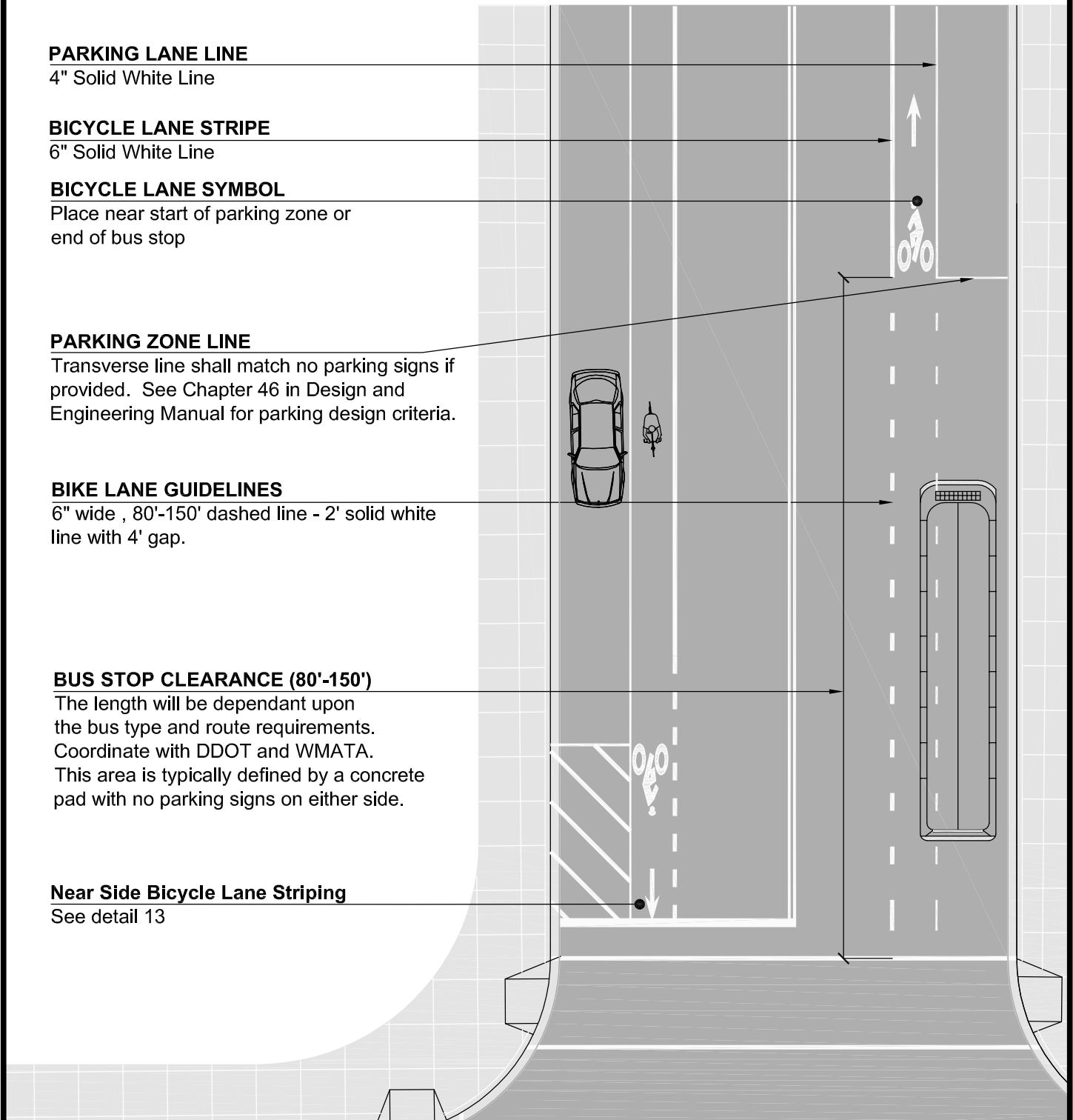

INTERSECTION WITH ONE WAY STREET

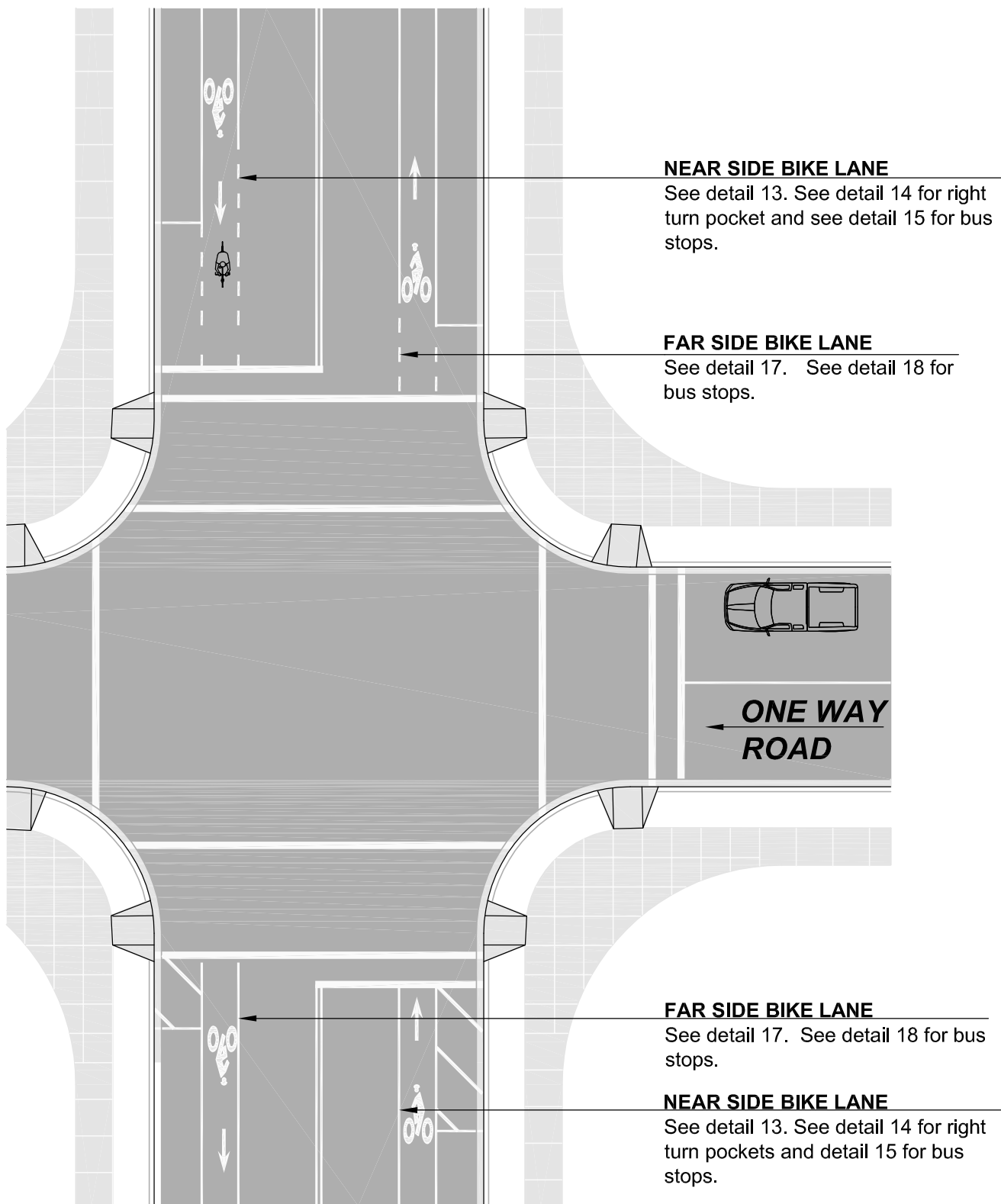

INTERSECTION WITH TWO WAY STREET

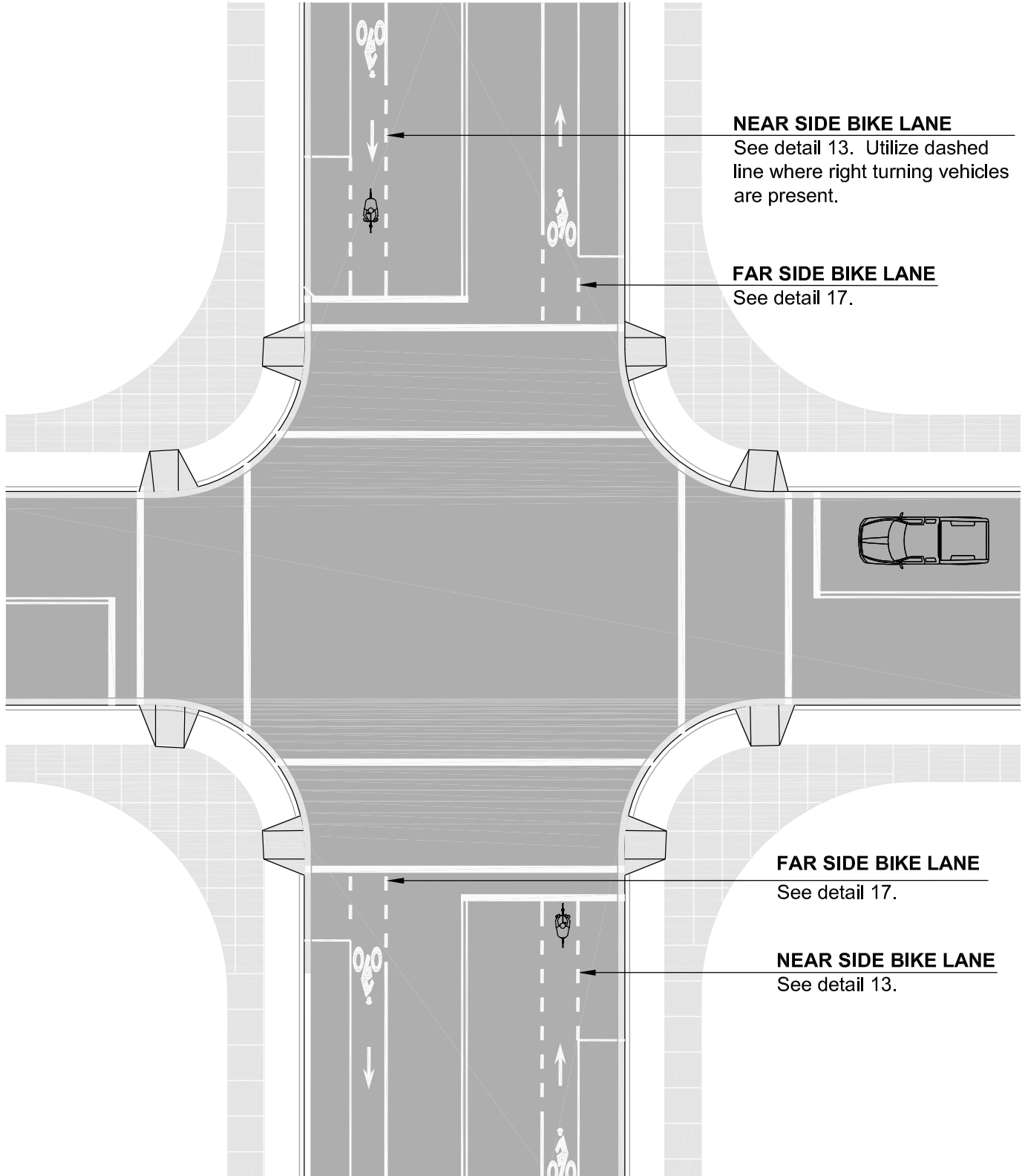

NEAR SIDE BIKE LANE

See detail 13. Utilize dashed line where right turning vehicles are present.

FAR SIDE BIKE LANE

See detail 17.

FAR SIDE BIKE LANE

See detail 17.

NEAR SIDE BIKE LANE

See detail 13.

THREE WAY INTERSECTION

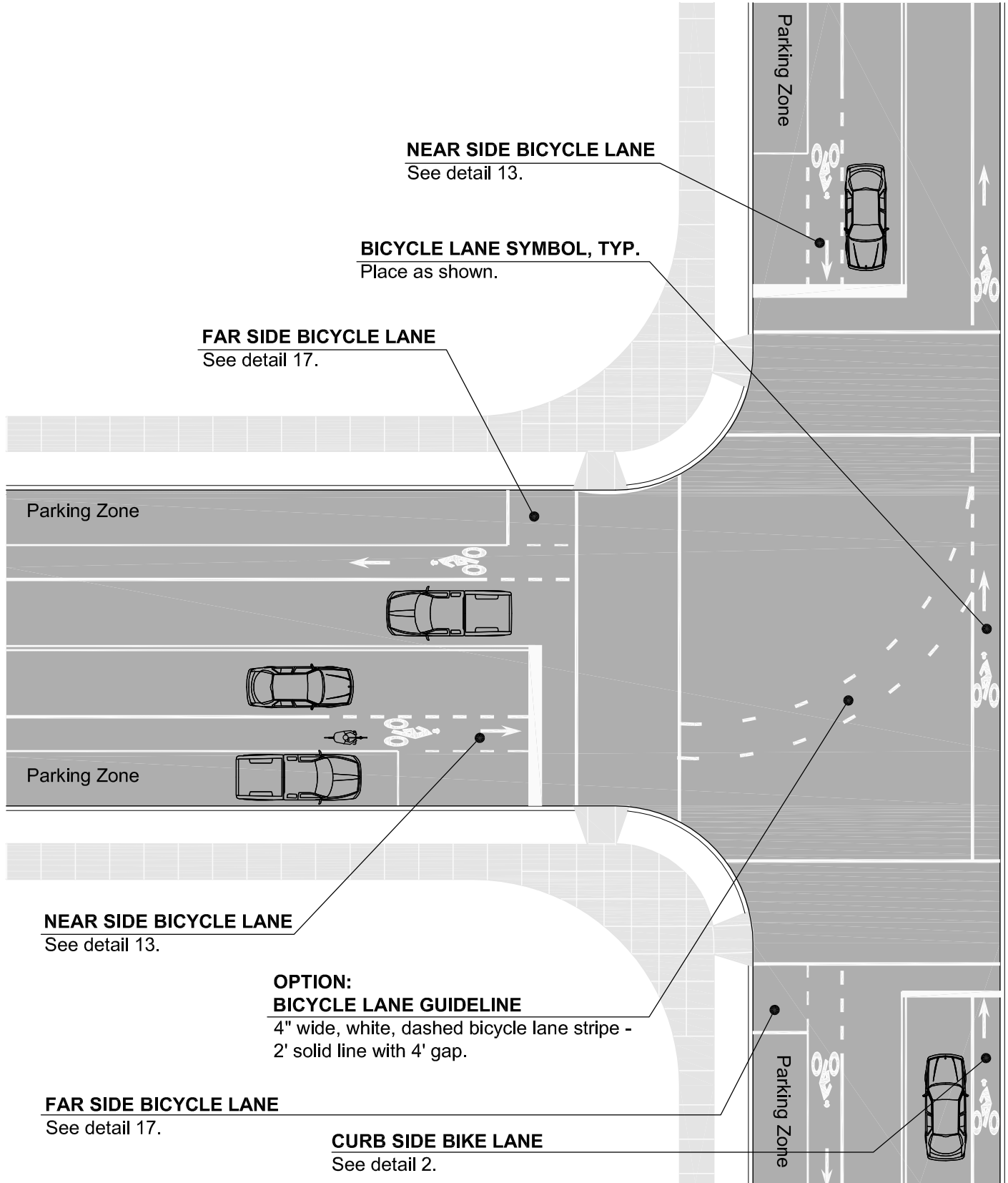

NEAR SIDE BICYCLE LANE
See detail 13.

BICYCLE LANE SYMBOL, TYP.
Place as shown.

FAR SIDE BICYCLE LANE
See detail 17.

Parking Zone

Parking Zone

NEAR SIDE BICYCLE LANE
See detail 13.

**OPTION:
BICYCLE LANE GUIDELINE**
4" wide, white, dashed bicycle lane stripe -
2' solid line with 4' gap.

FAR SIDE BICYCLE LANE
See detail 17.

CURB SIDE BIKE LANE
See detail 2.

Parking Zone

Parking Zone

BICYCLE FACILITY SYMBOLS

4'X8' BIKE LANE SYMBOL

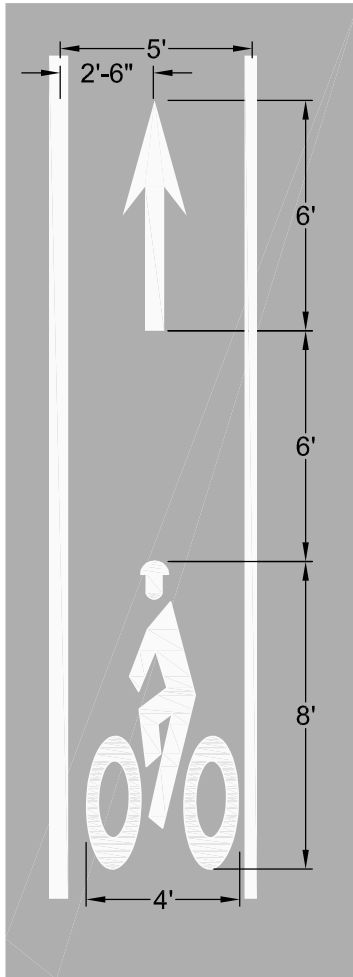

SHARED LANE SYMBOL

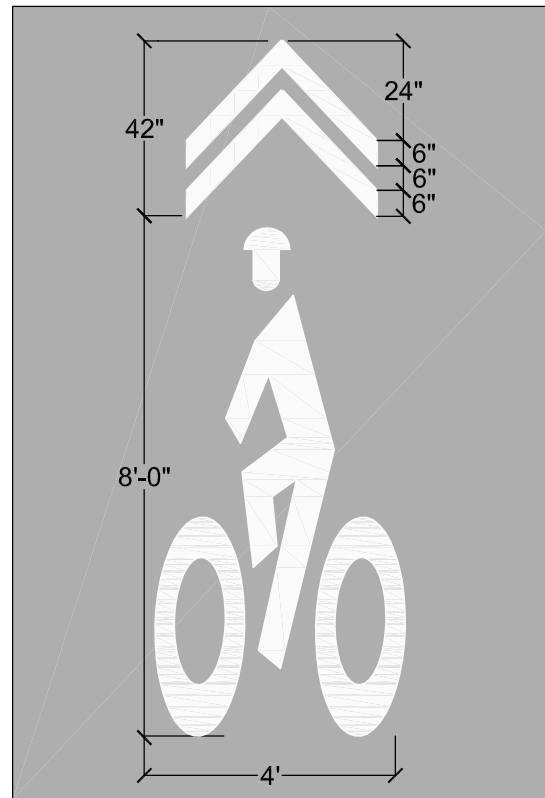

BICYCLE DETECTION SYMBOL

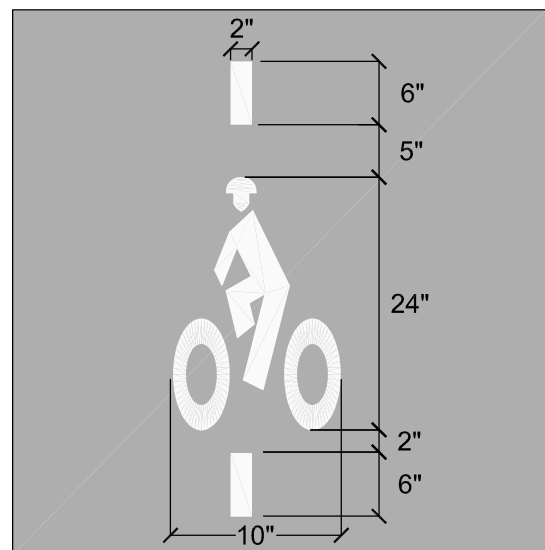

EXPERIMENTAL SHARED LANE SYMBOL PLACEMENT

WIDE OUTSIDE LANE

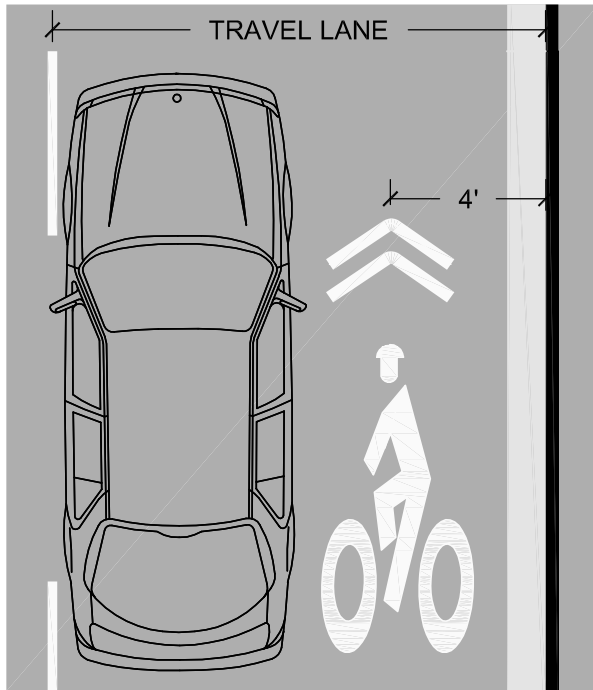

WIDE PARKING LANE

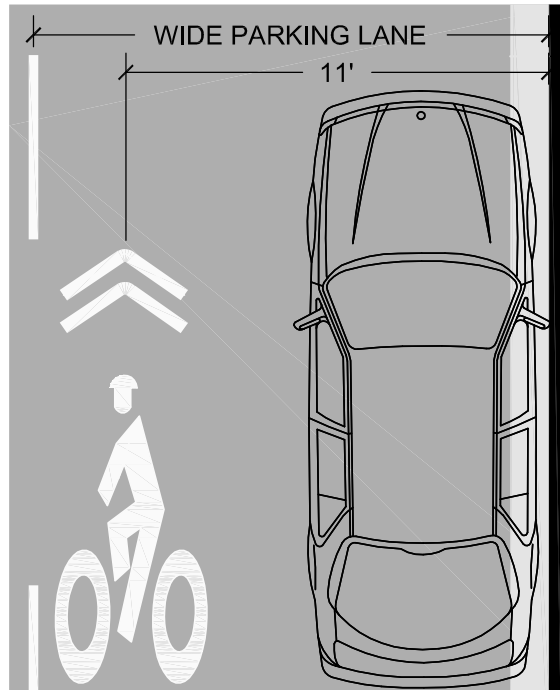

SYMBOL USE GUIDELINES:

1. Symbols may be used on roadways that are too narrow for bicycle lanes.
2. Symbols may be used on narrow roadways to connect disconnected bicycle facilities such as bicycle lanes, designated routes, and shared use paths.
3. Symbols may be used on roadways that have high levels of bicycle traffic.

SYMBOL PLACEMENT NOTES:

1. Symbols shall be placed after each intersection. Symbols may be placed every 250' thereafter.
2. If used on roadways with on-street parking, symbols shall be placed so that their centers are a minimum of 11' from the adjacent curb face.
3. Symbols placed in a shared lane without parking shall be placed so that their centers are a minimum of 4' from the adjacent curbface.
4. Do not place symbols on lane lines.
5. See detail 22 for shared lane symbol size.

WIDE OUTSIDE LANE ADJACENT TO PARKING

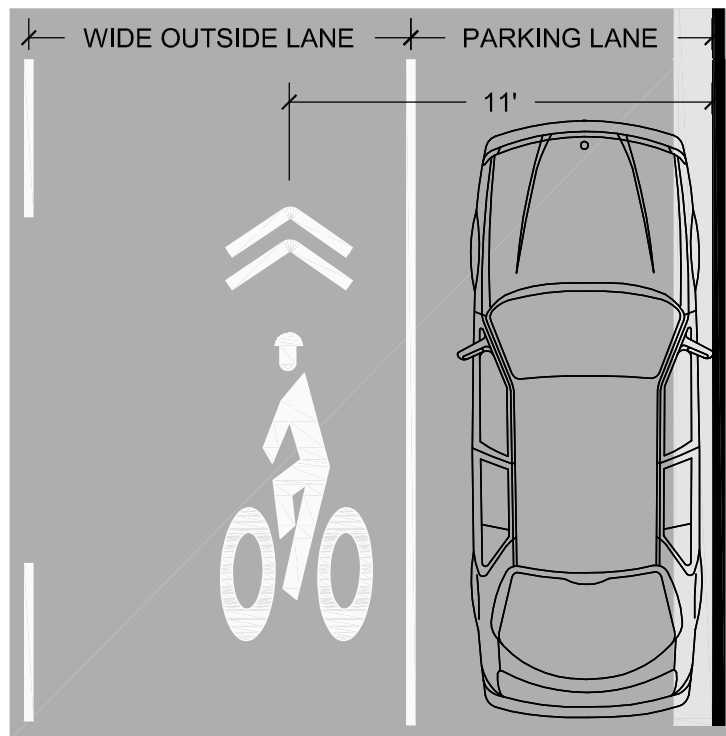

BICYCLE DETECTION AT ACTUATED SIGNALIZED INTERSECTIONS

SIGNAL ACTUATION SIGN (R10-22)

Place adjacent to pavement marking.

BICYCLE DETECTION ZONE

Utilize a diagonal quadrupole detector. Locate behind stop line.

DIAGONAL QUADRUPOLE PATTERN

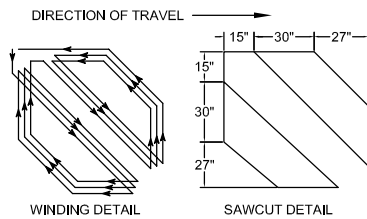

BICYCLE LOOP DETECTOR SYMBOL

Center directly over quadrupole bicycle detector. See detail 22 for symbol dimensions.

BICYCLE LANE SYMBOL

Place a minimum of 30 feet in advance of bicycle detector symbol

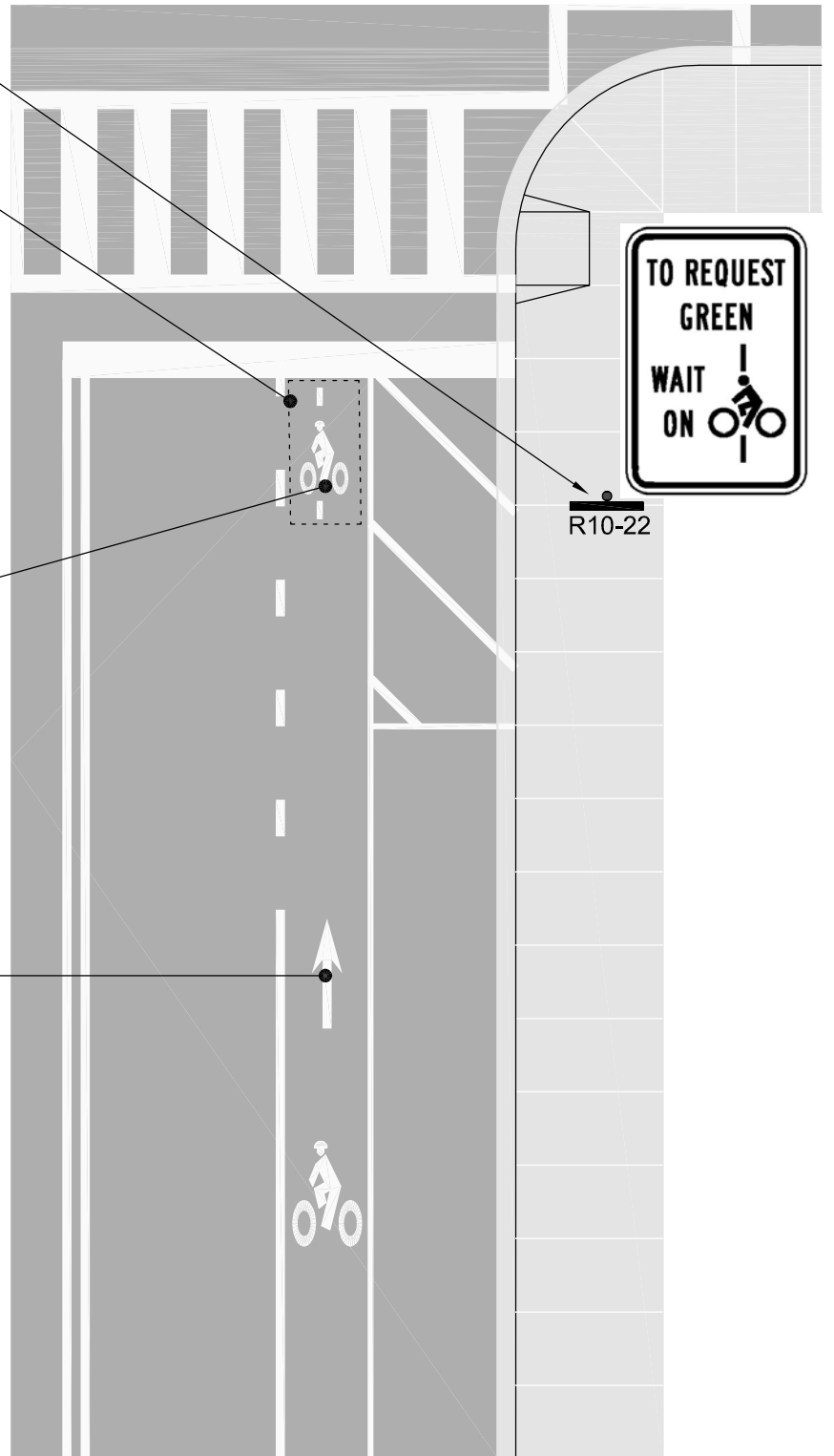

BICYCLE SAFE STORMWATER GRATES

ACCEPTABLE GRATE DESIGNS

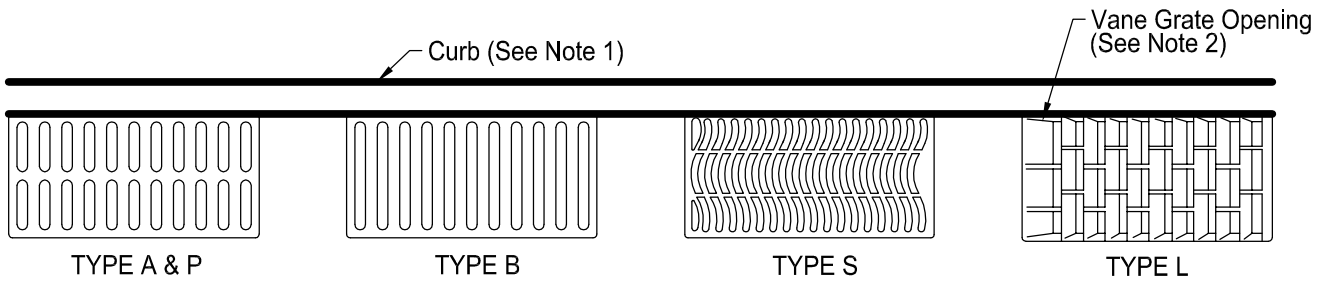

UNACCEPTABLE GRATE DESIGNS

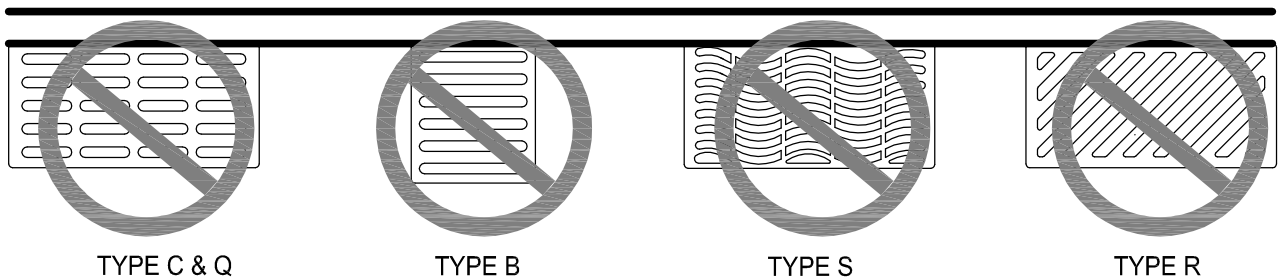

EXAMPLE INSTALLATION WITH VANE GRATE

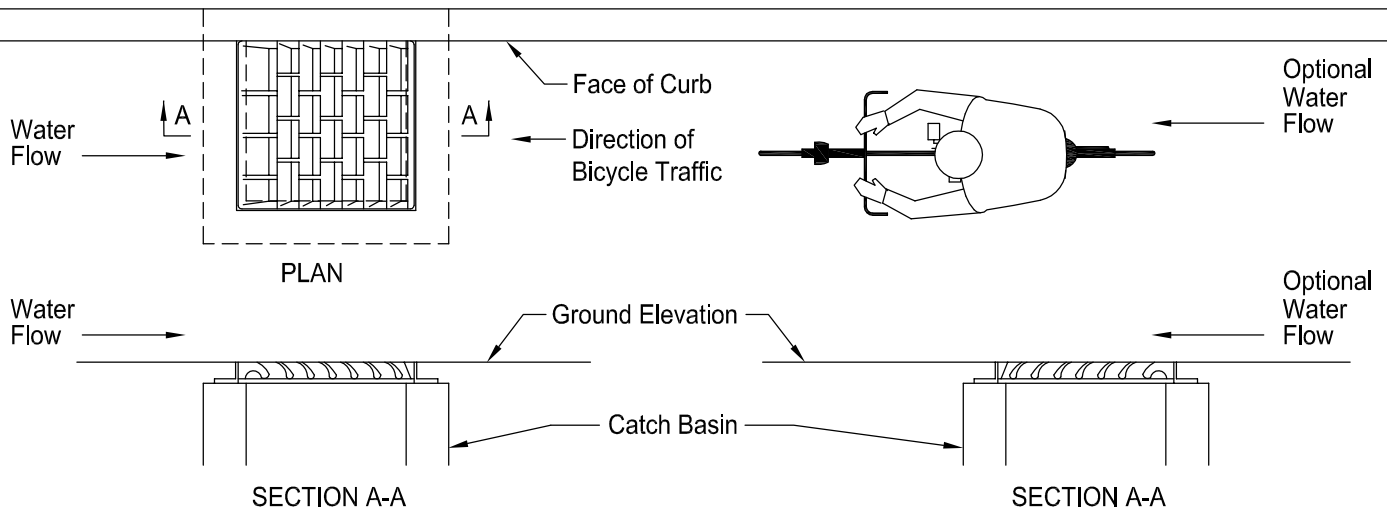

NOTES:

1. Grate types are only considered bicycle safe with the curb orientation as shown.
2. Vane grate openings are desirable in locations where higher hydraulic capacity is needed. The grate must be oriented with the direction of flow as shown in the "example vane grate opening" detail.
3. Grate types shown are based upon Neenah Foundry model numbers. Other manufacturer grates may be installed if they meet the grate design specifications shown here.

BICYCLE RACK DESIGNS

PREFERRED "U Rack" DESIGN

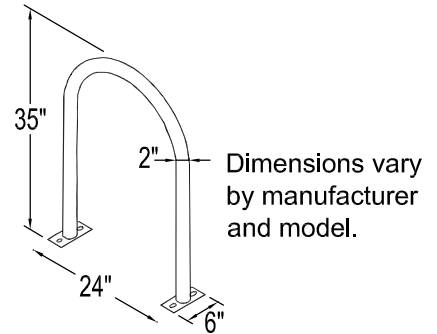

ACCEPTABLE DESIGNS



Golden Triangle
BID Style



Downtown
BID Style



UNACCEPTABLE DESIGNS



This type of rack can bend the wheel.



This type of rack does not support the bicycle frame in at least 2 places.

RACK ELEMENTS

The rack must:

- Support the bicycle frame in at least 2 places, allowing the frame and wheel to be locked using a U-lock or cable lock.
- Prevent the wheel of the bicycle from tipping over.
- Not damage the bicycle.
- Be durable and securely anchored.
- Allow front-in or back-in parking.

BICYCLE PARKING RACK PLACEMENT

RACK PLACEMENT

RULES:

5' from:

Fire hydrant
Crosswalk

4' from:

Loading zone
Bus stop
Bus shelter
Bus bench

Min. 2', Rec. 3' from:

Curb

3' from:

Parking meter
Newspaper rack
US mailbox
Light pole
Sign pole
Driveway
Tree space
Trash can
Utility meter
Manhole
Other street furniture
Other sidewalk obstructions

WALL SETBACKS

For racks set parallel to a wall:
Min. 24", Rec. 36"
For racks set perpendicular to a wall:
Min. 28", Rec. 36"

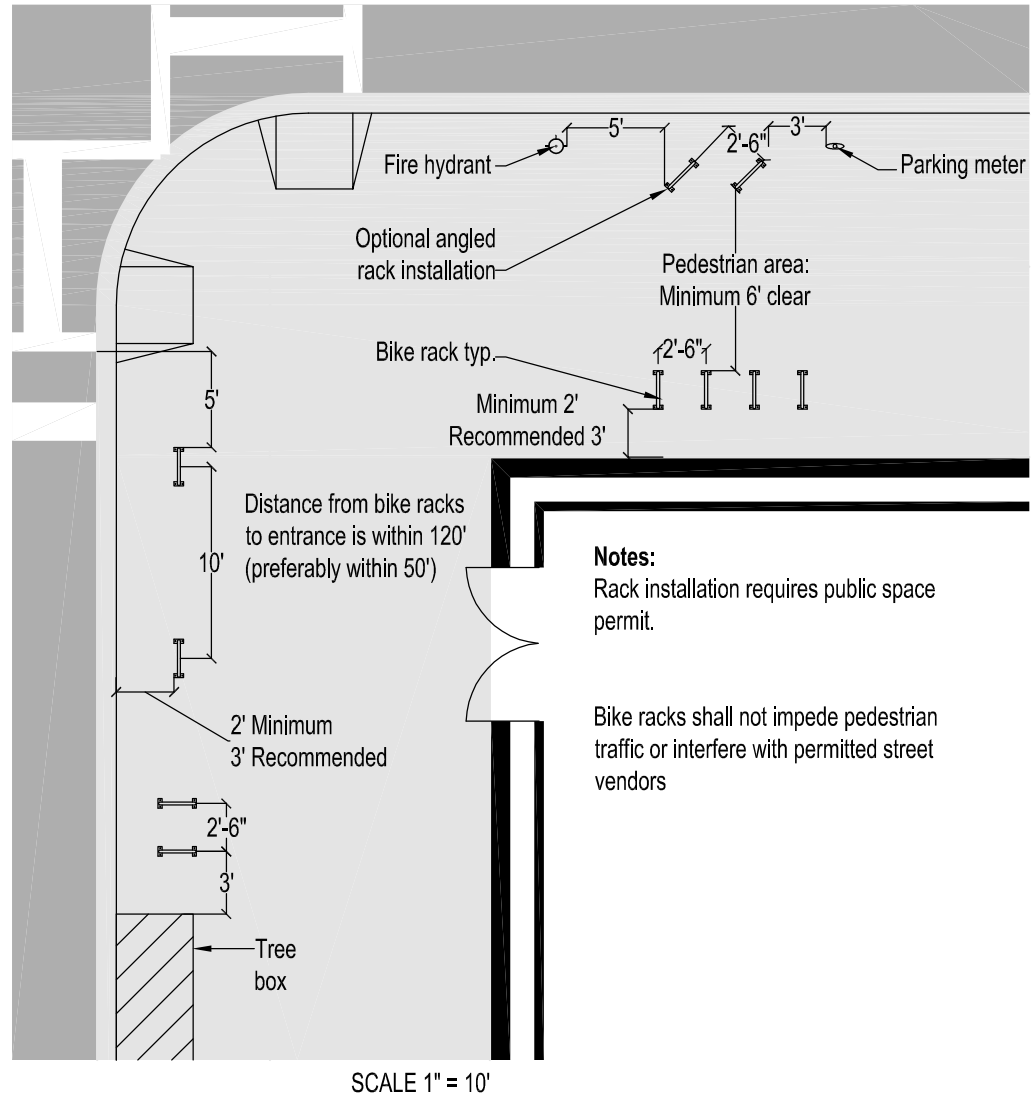

Notes:

Rack installation requires public space permit.

Bike racks shall not impede pedestrian traffic or interfere with permitted street vendors

SIDE VIEW

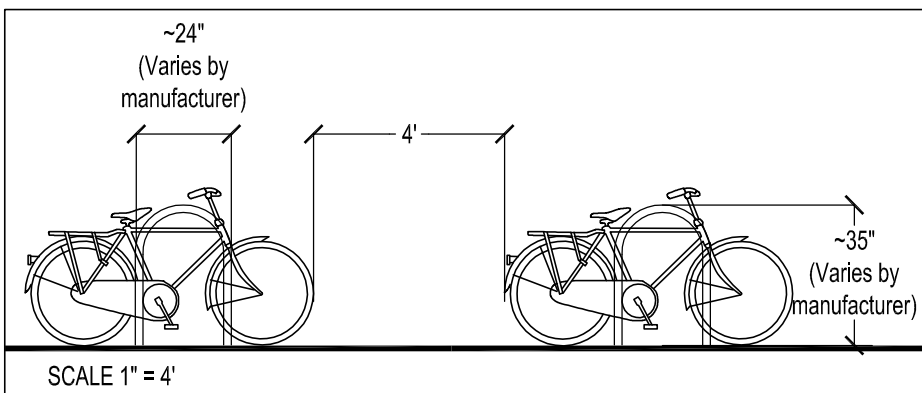

SIDE BY SIDE RACKS:

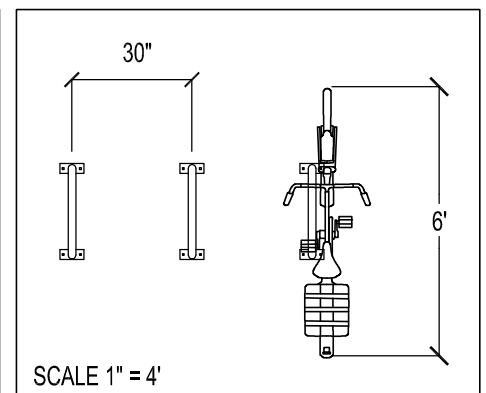

BIKE ROUTE SIGNS

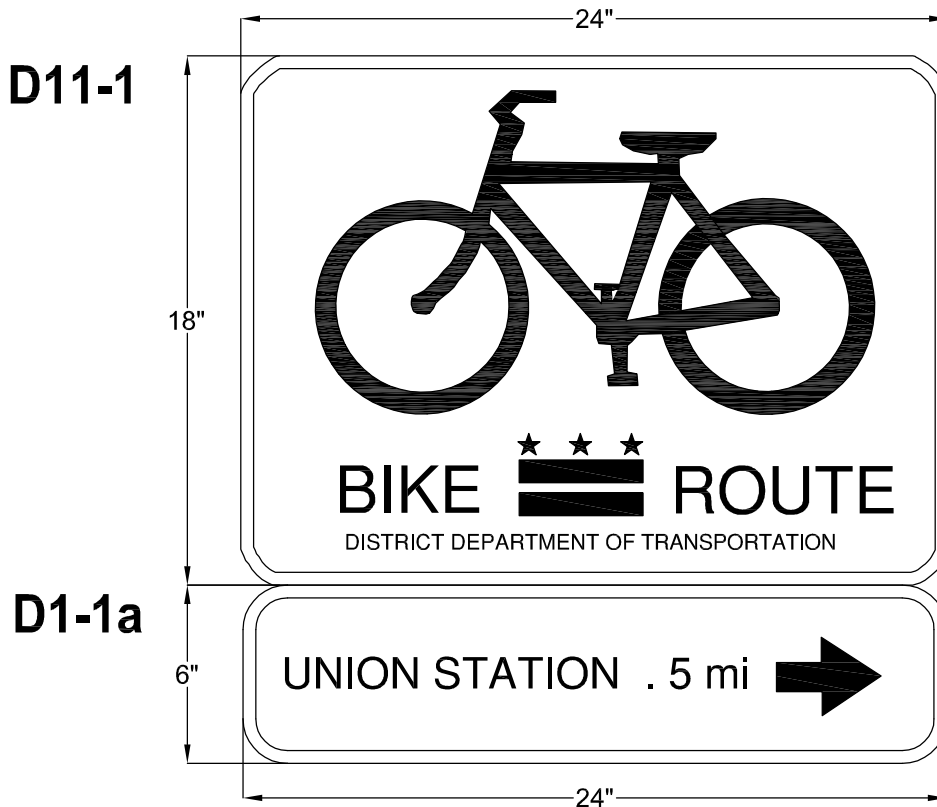

GUIDANCE:

Bicycle route guide (D11-1) signs should be provided at decision points along designated bicycle routes, including signs to inform bicyclists of bicycle route direction changes and confirmation signs for route direction, distance, and destination.

Destination (D1-1 AND D1-1a) signs shall be mounted below bicycle route guide signs to furnish additional information such as directional changes in the route, or intermittent distance and destination information.

INSTALLATION:

The sign shall conform to DDOT standards for letter height, symbol size, and layout. Signs must be installed according to DDOT sign hanging standards at the approval of the Bicycle Program Manager.

D11-1 SIGN DESIGN:

SOURCE: MODIFIED MUTCD
 SIZE: 18"x24"
 COLOR: white letters on
 green reflective background

D1-1a and D1-1b SIGN DESIGN:

SOURCE: STANDARD MUTCD
 SIZE: 6"x24"
 COLOR: white letters on
 green reflective background

RIGHT TURN YIELD TO BIKES SIGN



GUIDANCE:

If used, Begin Right Turn Lane - Yield to Bikes (R4-4) signs should be provided at the beginning of a right turn lane to inform bicyclists and motorists of the merging area. These signs should only be installed at locations where there is a dedicated right turn area (buses may be excepted). They should always be installed where there is a dedicated bicycle facility marked as a bicycle lane or shared roadway.

INSTALLATION:

The sign shall conform to DDOT standards for letter height, symbol size, and layout. Signs must be installed according to DDOT sign hanging standards at the approval of the Bicycle Program Manager.

R4-4 SIGN DESIGN:

SOURCE: STANDARD MUTCD
SIZE: 36"x30"
COLOR: black letters on
white reflective background

**EXPERIMENTAL SIGN
BICYCLES MAY USE FULL LANE**



OPTION:

The bicycles may use full lane (R4-11) sign may be used on roadways with no bicycle lanes or adjacent shoulders usable by bicyclists and where travel lanes are too narrow (11 feet or less) for bicyclists and motor vehicles to operate side by side.

The bicycles may use full lane sign may be used in locations where it is important to inform road users that bicyclists may occupy the travel lane in order to prevent unsafe passing.

INSTALLATION:

The sign shall conform to DDOT standards for letter height, symbol size, and layout. Signs must be installed according to DDOT sign hanging standards at the approval of the Bicycle Program Manager.

R4-11 SIGN DESIGN:

SOURCE: PROPOSED FOR MUTCD (NCUTCD COMMITTEE)

SIZE: 30"x30"

COLOR: black letters on
white reflective background

EXPERIMENTAL SIGN LOOK FOR BIKES



OPTION:

The Look For Bikes Sign may be installed in location where there is a need to inform motorists to exercise caution when opening vehicular doors to avoid striking a bicyclists. It also serves to warn bicyclists to be cautious when passing parked motor vehicles to avoid being struck by an opening door.

The Look For Bikes Sign may be installed in locations where bicycle lanes are striped adjacent to 7' parking lanes or in locations where bicycle lanes are installed adjacent to high turnover parking lanes.

INSTALLATION:

The sign shall conform to DDOT standards for letter height, symbol size, and layout. Signs must be installed according to DDOT sign hanging standards at the approval of the Bicycle Program Manager. It is recommended that the signs be installed above or below existing parking regulation signs.

SIGN DESIGN:

SOURCE: BASED UPON A SIGN IN NEW YORK CITY

SIZE: 18"x24"

COLOR: black letters on
yellow reflective background

TRAIL CROSS SECTION

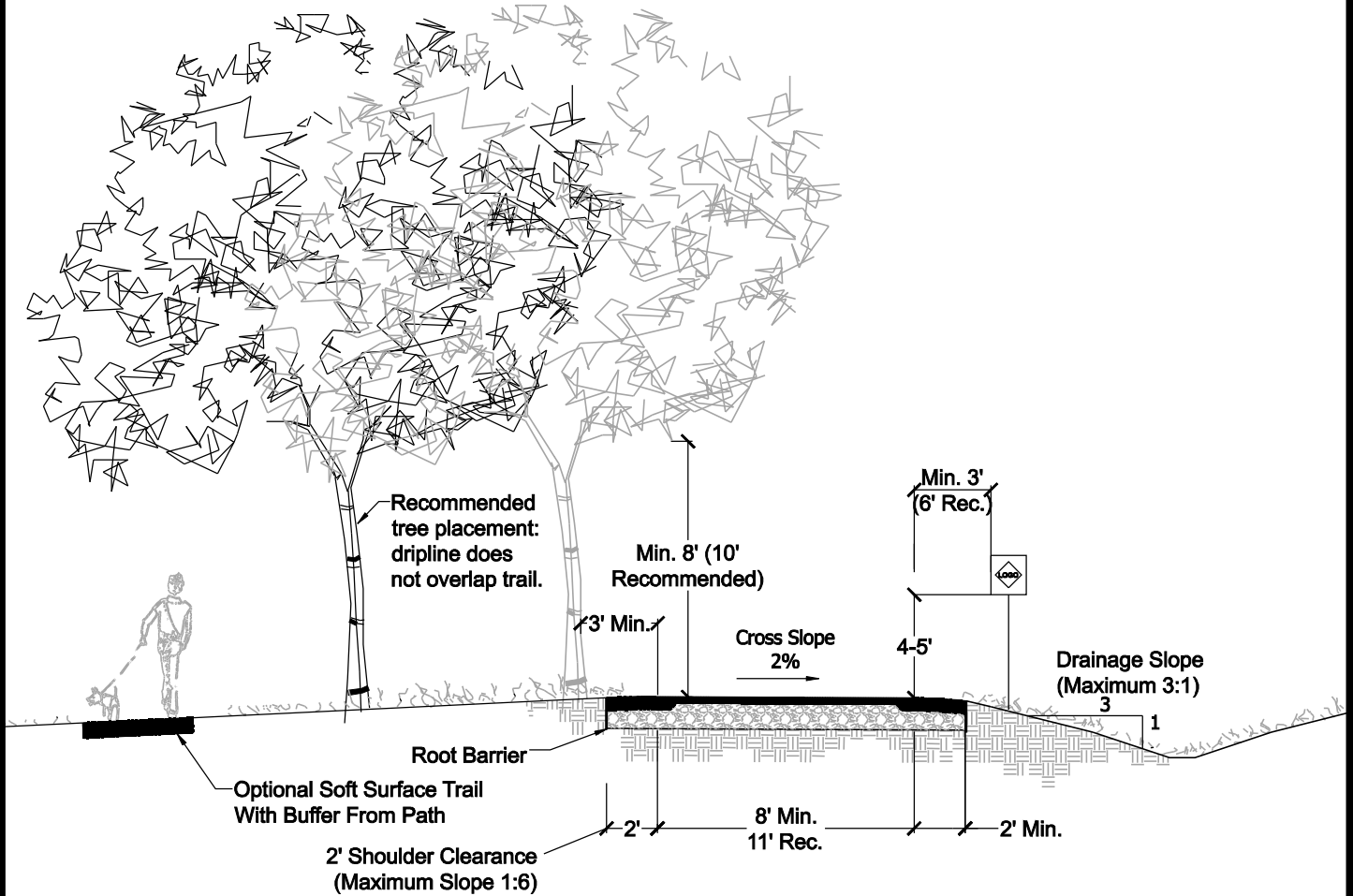

NOTES:

1. For high use trails (Rock Creek, Metropolitan Branch, etc.), 11' widths should be the minimum to provide three lane operation. Consideration should be given to providing additional width as necessary.
2. Pedestrian jogging space should be considered adjacent to the trail. Consideration should be given to creating a buffer space between walking/jogging trails and the path.
3. Signs along the path must be installed according to the MUTCD regulations and DDOT standards.
4. Provide positive drainage across the trail to prevent siltation buildup and water ponding.

SHARED USE PATH/ROADWAY CROSSING

CROSSWALK STRIPING

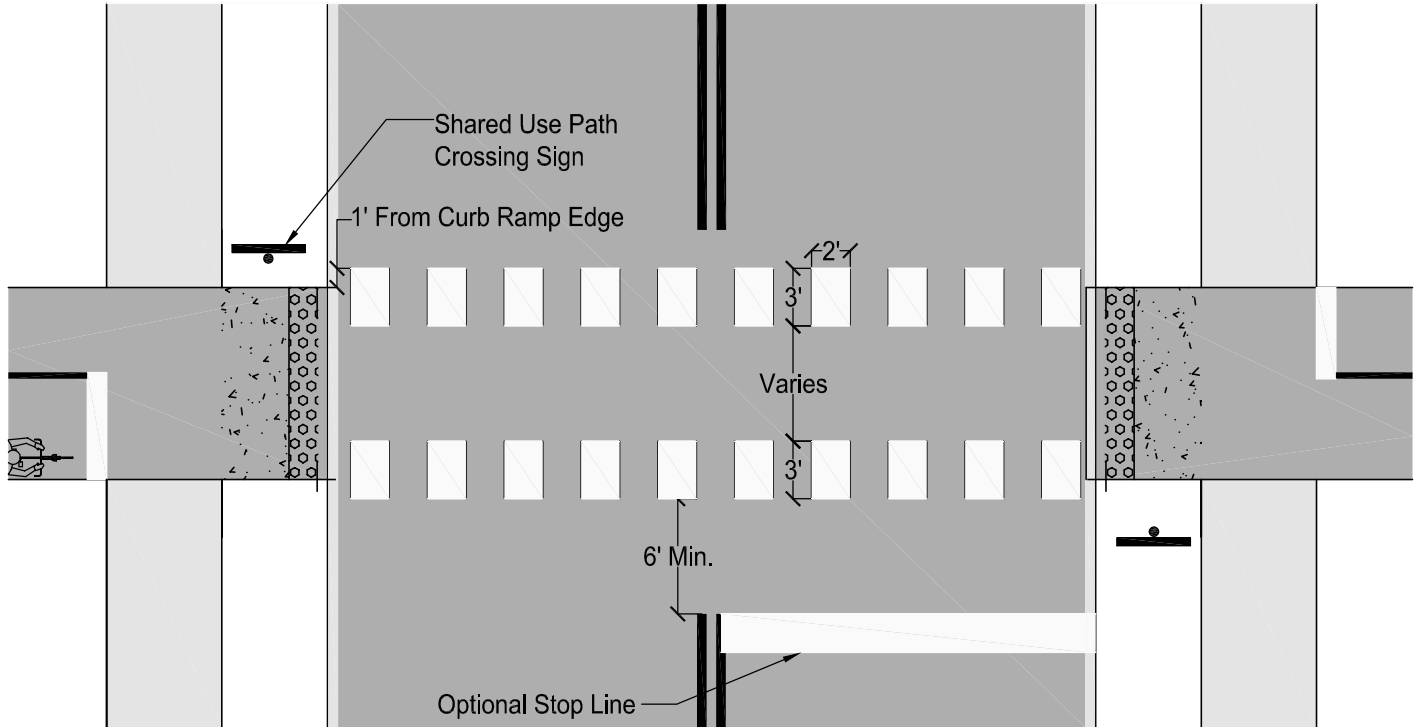

SHARED USE PATH CROSSING SIGN

GUIDANCE:

Place at all shared use path crossings in accordance with provisions set forth for W11-1 sign in MUTCD section 9B.17.

Modified W11-1 Sign:

Source: Modified MUTCD

Size: 24 x 24

Color: fluorescent yellow/green background with white text



SHARED USE PATH CROSSING AT A FOUR WAY INTERSECTION

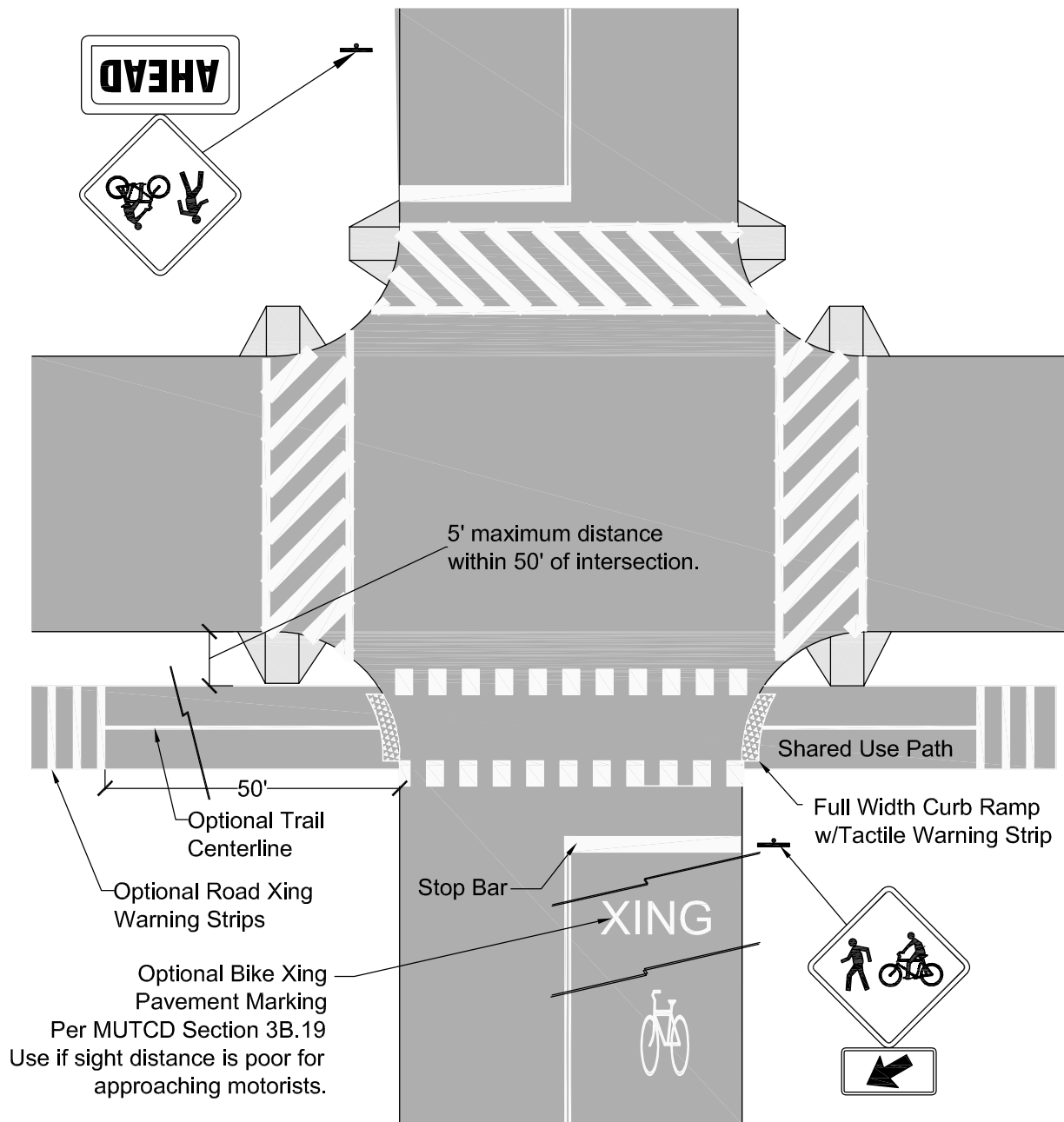

Notes:

1. Provide adequate site distance for all approaches per AASHTO Guidelines.
2. Trail traffic control should be determined in accordance the MUTCD for both the trail and the adjoining roadway.
3. Roadway configuration and striping will vary.
4. Curb ramps shall match full width of path at intersections and meet ADA requirements.
5. OPTION: Utilize advanced stop here for pedestrian sign, advanced stop line, or in street stop for pedestrian sign. See MUTCD sections 3B.16, 2B.11 and 2B.12 for further explanation.

SHARED USE PATH CROSSING MIDBLOCK INTERSECTION

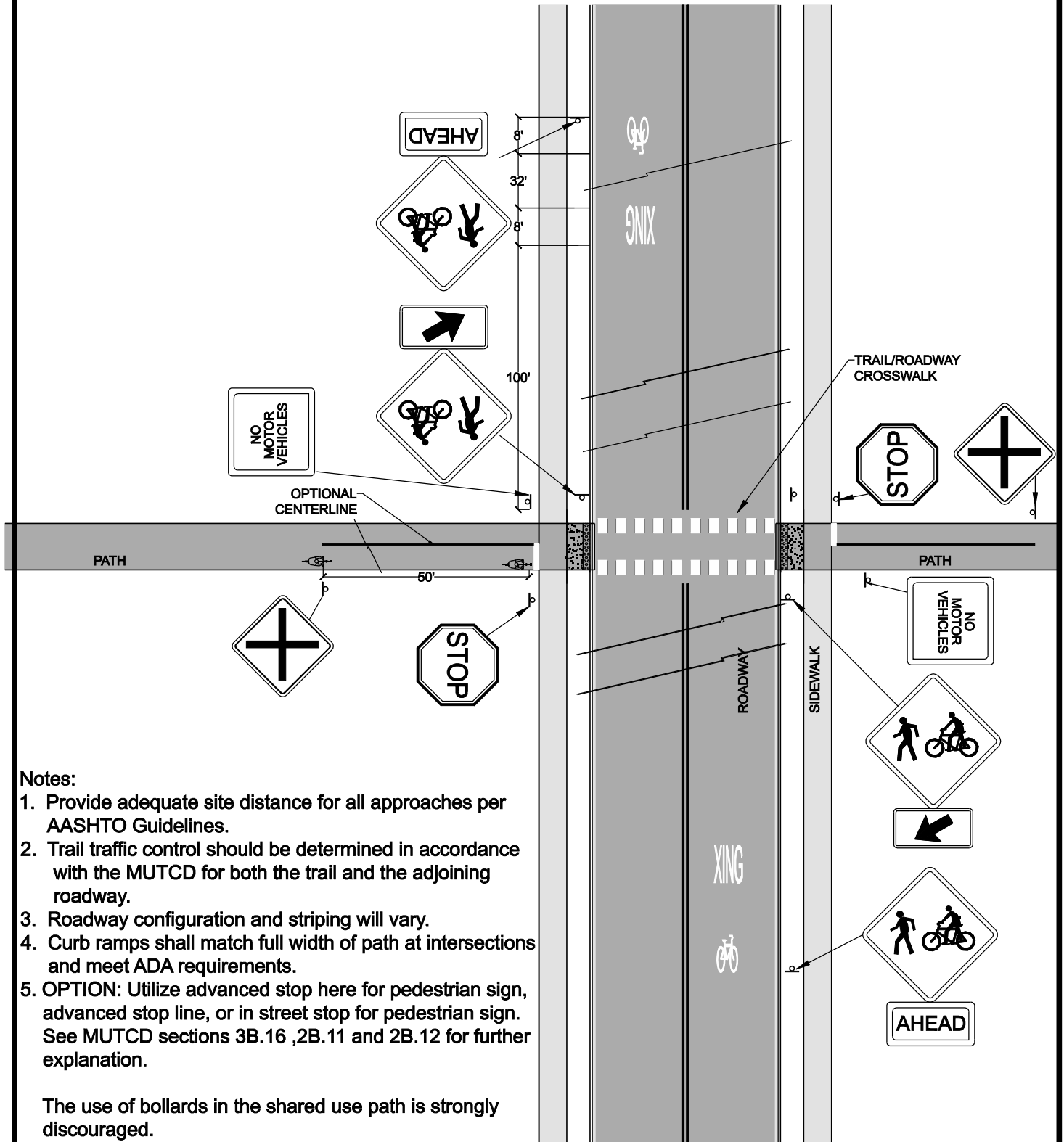

Notes:

1. Provide adequate site distance for all approaches per AASHTO Guidelines.
2. Trail traffic control should be determined in accordance with the MUTCD for both the trail and the adjoining roadway.
3. Roadway configuration and striping will vary.
4. Curb ramps shall match full width of path at intersections and meet ADA requirements.
5. OPTION: Utilize advanced stop here for pedestrian sign, advanced stop line, or in street stop for pedestrian sign. See MUTCD sections 3B.16, 2B.11 and 2B.12 for further explanation.

The use of bollards in the shared use path is strongly discouraged.

MIDBLOCK CROSSING MEDIAN REFUGE

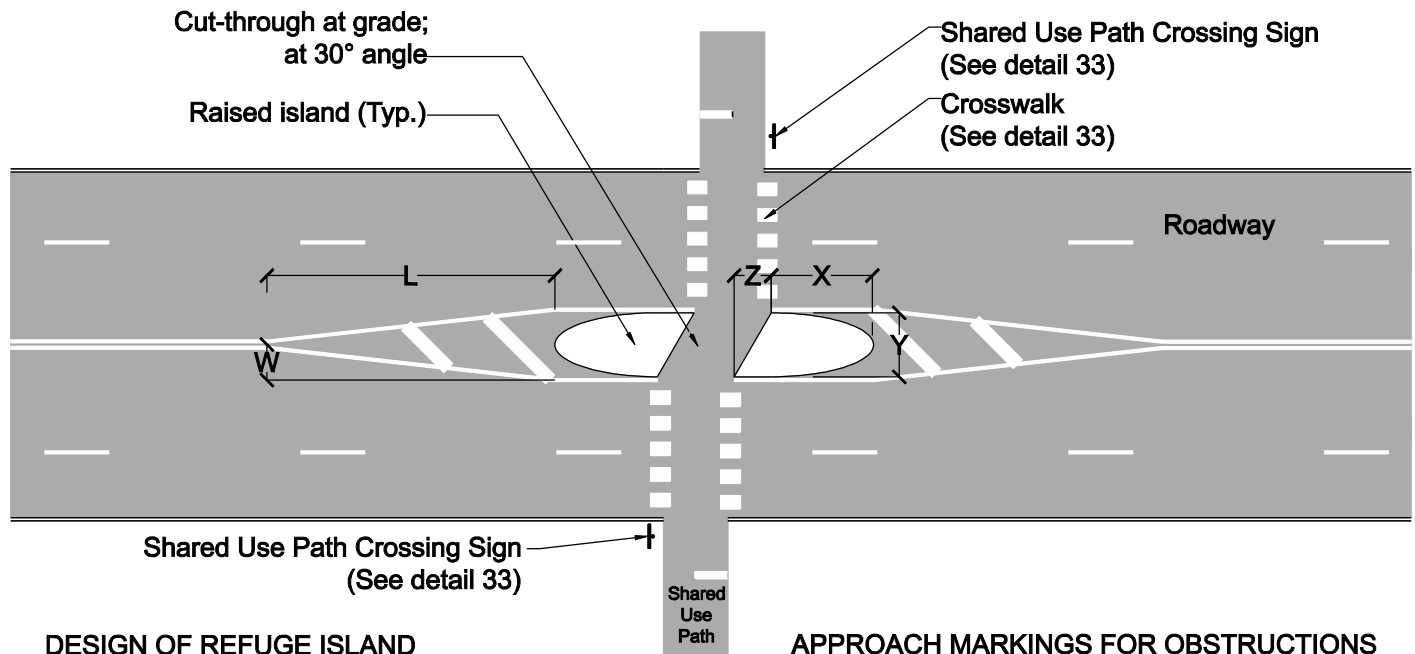

DESIGN OF REFUGE ISLAND

$$Z \text{ (offset)} = \frac{Y}{2}$$

X = Length of island should be 6' or greater

Y = Width of refuge:
 6' = poor
 8' = satisfactory
 10' = good

APPROACH MARKINGS FOR OBSTRUCTIONS IN ROADWAY

For English Units:

$$L = \frac{WS^2}{60}, \text{ where } S < 45 \text{ mph}$$

$$L = WS, \text{ where } S \geq 45 \text{ mph}$$

See Section 3B.10 in the MUTCD for further information.

Notes:

1. Provide adequate site distance for all approaches per AASHTO Guidelines.
2. Trail traffic control should be determined in accordance with the MUTCD for both the trail and the adjoining roadway.
3. Roadway configuration and striping will vary.
4. Curb ramps shall match full width of path at intersections and meet ADA requirements.
5. OPTION: Utilize advanced stop here for pedestrian sign, advanced stop line, or in street stop for pedestrian sign. See MUTCD sections 3B.16, 2B.11 and 2B.12 for further explanation.