

Bussing Cart

Ideal 3 shelf cart for bussing, serving or general stocking. Unit comes in aluminum or stainless steel to fit any customer's need or preference. The attractive design is appropriate for any occasion.



8040569 Shown

FEATURES:

- All welded construction
- 400 lb. capacity
- 13" shelf spacing

OPTIONS:

- Aluminum or stainless steel construction

REPLACEMENT PARTS:

- 5" x 1.25" polyurethane wheels . Replacement Order #B000325





Freight Class: 300
 NMFC Code: 164390-S2

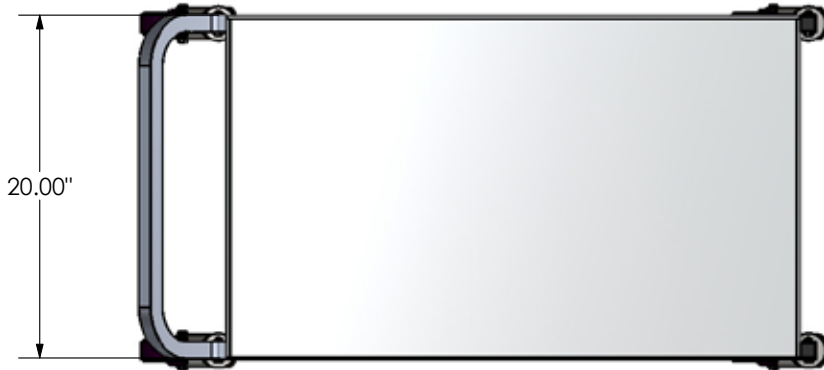

8040569

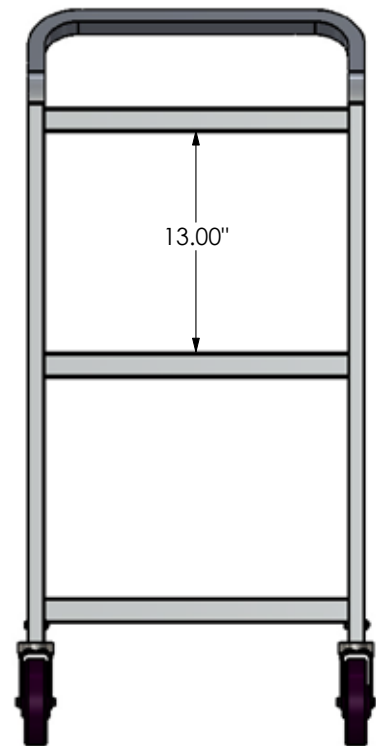
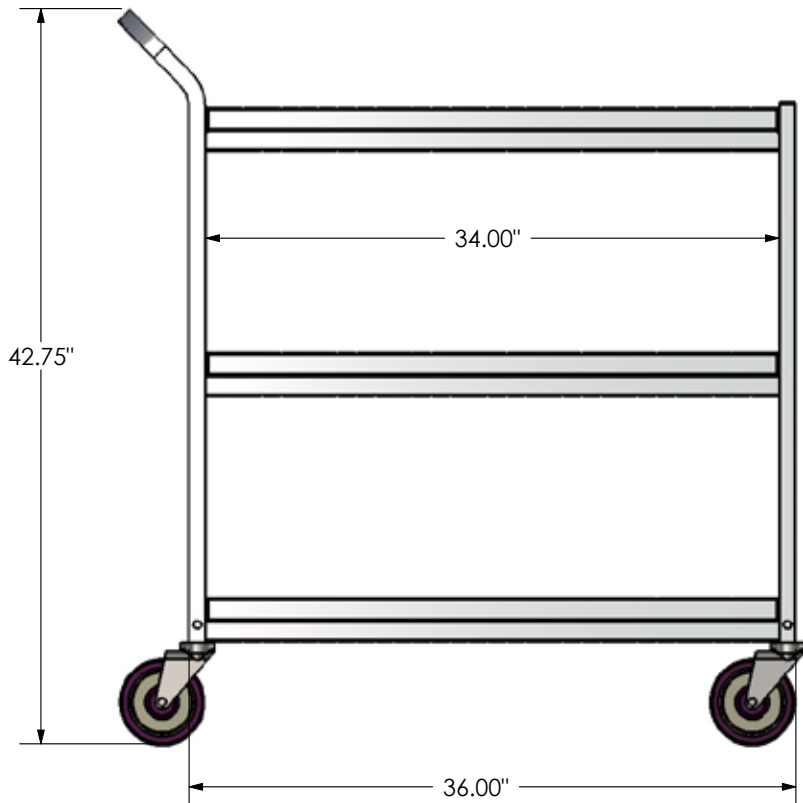

Order #	Model	W	L	H	Capacity	Weight
8040569	AL-BC-2036-3	20"	36"	42 3/4"	400 lbs.	35 lbs.
8050009	SS-BC-2036-3	20"	36"	42 3/4"	400 lbs.	59 lbs.

Can't find exactly what you need? Give us a call and we'll help you with the perfect solution!



NATIONAL CART CO

PH: 800-455-3802

www.nationalcart.com

Revision Date: Mar. 2013