



2340 South 900 West

Salt Lake City, UT 84119

801-974-9116 Fax: 801-974-5458

GRAVITY HILL

OPERATING INSTRUCTIONS

*** MACHINE MUST BE LEVEL TO OPERATE PROPERLY!**

**** REFER TO OWNERS MANUAL TO ADJUST DIFFICULTY OF PLAY!!**

GRAVITY HILL

DESCRIPTION

Gravity Hill is an interactive skill game with instant prize redemption. It incorporates a two-tiered prize system consisting, of a Small Prize and a Grand Prize.

GAME OBJECTIVE

The object of the game is to move a ball up the hill to the Small Prize hole or Grand Prize hole without falling off. This is accomplished by rocking the hill from side to side using the handle bars.

GAME FEATURES

- < Addictive music tracks that run during game play
- < Sound effects that enhance the game and encourage the player
- < Two different play balls for variety. Each ball has a unique feel and/or play
- < Removable bumpers and bridge to increase or decrease the play difficulty
- < Variable game play time limit
- < Tilt feature; play terminated when unit is tilted
- < Optional "Winner Every Play"

MACHINE FEATURES

- < Heavy duty construction
 - < Mars bill acceptor, stacker. (Optional)
 - < Play counter
 - < Volume control
 - < Rope light controller
 - < Stem glide levelers
 - < Display shelf to show Grand Prize products
 - < Dispenses a variety of Small Prizes:
 1. 27mm or 32mm super balls
 2. 850 or 600 count gumballs
 3. 850 or 600 count jawbreakers
 4. 1040 count Sweet Revenge
 5. 700 count Megabytes
 6. 1 to 1¼" round capsules
 - < Dispenses a 3¾ to 4" (95mm to 100mm) capsule for the Grand Prize
 - < Small Prize capacity: 2-3 cases of product
 - < Grand Prize capacity: 42 4" (100mm) capsules
 - < 220 volt option available
 - < Coin acceptors for tokens or foreign coins available
 - < Time and credit display
 - < Variable game time
 - < Game default set for 50 cent vend;
can be set for 1 to 4 coins
 - < Attract mode
 - < Winner every play
 - < Ball kick back feature
 - < Decreasing time option
 - < Small & Grand Prize count
- 
- See Menu Options for Instructions

OPERATING INSTRUCTIONS

1. Located in the coin cash box are:
 - < Different play ball (steely)
 - < Extra fuse
 - < Velcro
 - < Spanner security bits (snake eye)
 - < Extra rubber bumpers and clear bridge
 - < Instructions and decals for bill and coin acceptors
 - < Menu Options are located on inside door of coin cash box
2. Use stem glide levelers underneath unit to level machine (see figure 1).
3. Load Small Prize and Grand Prize products in the rear by removing locks in upper back door (see figure 2). Load Grand Prize capsules one at a time starting with the lowest row, working up to top row (see figure 3). Load Small Prize product by dumping product into the Small Prize hopper (see figure 4). Utilize extra Small Prize product storage **if necessary** by dumping product at the top of the extra storage column (see figure 5) after Small Prize hopper has been filled. After all product is filled, replace upper back door.
4. Set up your Grand Prize product displays by removing the front shield from machine by unscrewing the security screws (using bit) located on each side of the unit (see figure 6) and removing the front shield locks located in the rear left and right pillars (see figure 3). Attach displays with velcro (found in coin cash box).
5. Test Small and Grand Prize dispensers by starting play with bill or coins and drop the play ball through the Small Prize hole and repeat process for the Grand Prize.
6. Replace front shield with top edge positioned behind top portion of display shelf (see figure 8). Replace security screws (figure 6) and front shield locks (figure 3).
7. The circuit board is located through the lower back door (see figure 9). This provides service access to the board and its components.
8. Access to volume control and rope light controller is possible from the lower back door or through the bill/coin acceptor door (see figure 10a and 10b).
9. Counter is mounted in the rear of the upper coin door and can be easily viewed when door is fully opened (see figure 11).
10. Menu Options are located on inside door of coin cash box and on the next page. Red and yellow menu buttons are located next to the counter (see figure 11).
11. Game play comes preset for easy play. This means there are clear rubber bumpers placed on the hill in strategic locations that help keep the ball in play (see figure 12b). These can be removed to increase the difficulty of play or more added to increase the ease of play. There is also a clear bridge over a cut out in the middle of the play field (see Figure 12a). Removing the bridge increases the degree of difficulty.
12. For technical service and trouble shooting please call our **Gravity Hill** technical service representative at 1-801-974-9116. Technical drawings are available upon request.

GRAVITY HILL MENU OPTIONS

Menu options are displayed and modified using two buttons. The red button will cycle through the eight menu options advancing to the next option each time it is pressed. The yellow button will cycle through the available settings for the selected menu option. Pressing the yellow button on options 7 or 8, (the Small Prize and Grand Prize counters) will reset the count to zero.

Gravity Hill Options:

1. **Game Time** (defines the length of play)
 1 = 15 sec.
 2 = 30 sec.
 3 = 45 sec. (default)
 4 = 60 sec.
 5 = 75 sec.
 6 = 90 sec.
 7 = 105 sec.
 8 = 120 sec.

2. **Coins to Start** (number of coins for one credit)
 1 = 1
 2 = 2 (default)
 3 = 3
 4 = 4

3. **Attract Mode** (attract sound plays every 5 minutes for about 10 seconds)
 0 = Off
 1 = ON (default)

4. **Winner Every Time** (dispenses a Small Prize with every play)
 0 = Off
 1 = On (default)

5. **Ball Kick Back** (returns play ball for continued play if ball falls off in the first 10 seconds of play)
 0 = Off
 1 = On (default)

6. **Decreasing Time Option** (play time decreases in 15 second intervals with each consecutive Grand Prize win)
 0 = Off
 1 = On (default)

7. **Small Prize Count***
 Displays the # of Small Prizes dispensed

8. **Grand Prize Count***
 Displays the # of Grand Prizes dispensed

* Displays 3 & 4 digit numbers by using top and bottom LEDs

OPERATING SUGGESTIONS

1. To change the degree of play difficulty
 - , **Adjust the play time limit up or down**
 - , **After two weeks, remove the lowest clear bumpers**
 - , **After 3-4 weeks remove the rest of the clear bumpers**
 - , **To increase difficulty of play remove clear bridge over the cut out located in the middle of the play field (figure 12a)**
 - , **Periodically change the play ball**
 - , **Adjust tilt of play field (figure 18 & 19)**
 - , **Front or rear stem glide levelers (feet) can be raised or lowered to adjust tilt of game**
 - , **Purchase new, more difficult play field**

2. To keep revenues up
 - , **Change product and product display every two weeks**
 - , **Licensed prize selections available**

PLAY FIELD REPLACEMENT

1. Remove the front shield from machine by unscrewing the security screws (using spanner security bit) located on each side of the unit (see figure 6) and removing the locks located in the center rear left and right pillars (see figure 3).
2. Remove the seven 7/16 cap nuts located on the black bottom tray (see figure 13) and remove the two wafer head screws at the front of the black bottom tray located in front of the play field (see figure 13). Remove ball delivery channel.
3. Lift bottom tray out of unit one half at a time (see figure 14). Note: left side tray has two sets of wires connecting to micro-switches at the front and rear of the tray. Disconnect wires from micro-switches taking note which pins they are connected to.
4. Remove the six wafer head screws located around the edge of the play field (see figure 15 & 15A).
5. Separate play field from black plastic backing.
6. Place new play field onto playing backing and attach with the six wafer head screws.
7. Replace both sides of the black bottom tray, making sure wires on left side are properly attached to the micro-switches. Secure using the cap nuts and replace the ball delivery channel and two wafer head screws.
8. Replace the front shield securing with the snake eye security screws and front shield locks.

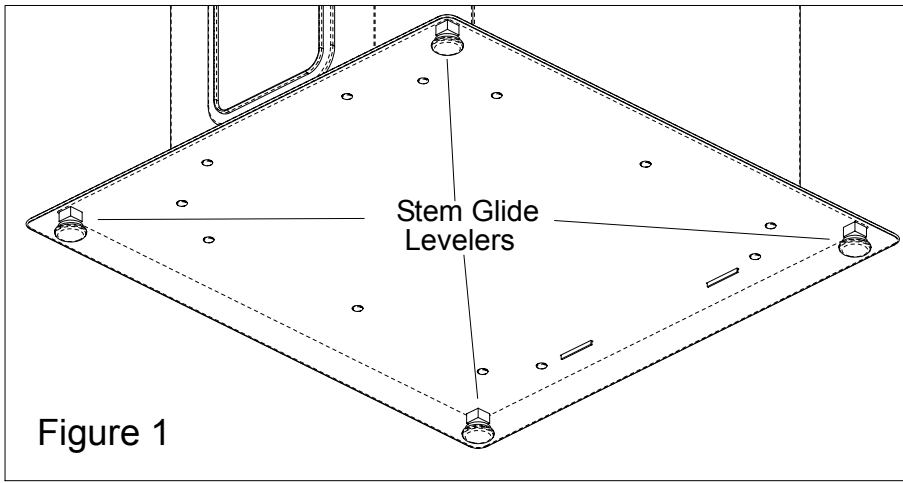

Figure 1

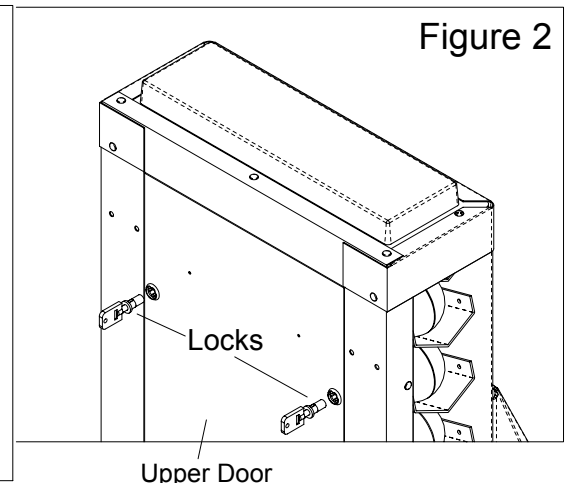

Figure 2

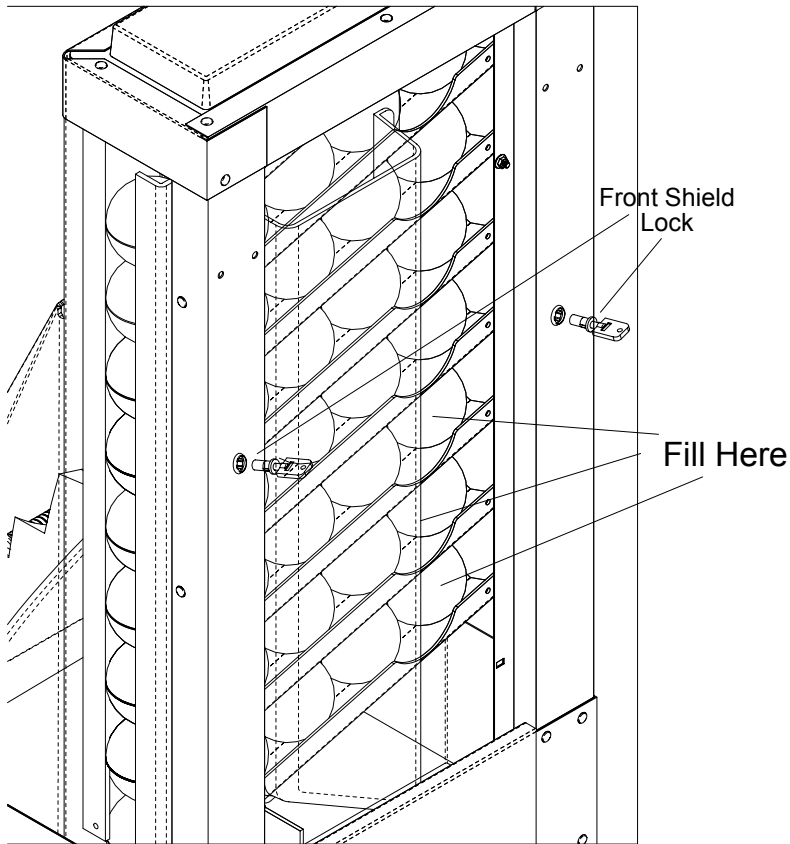

Figure 3

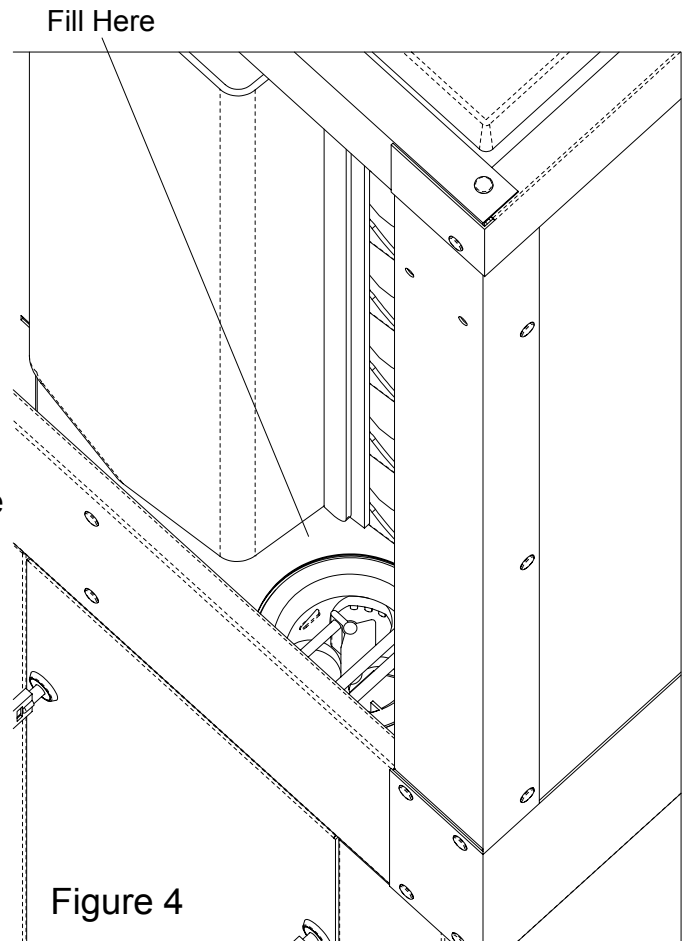

Figure 4

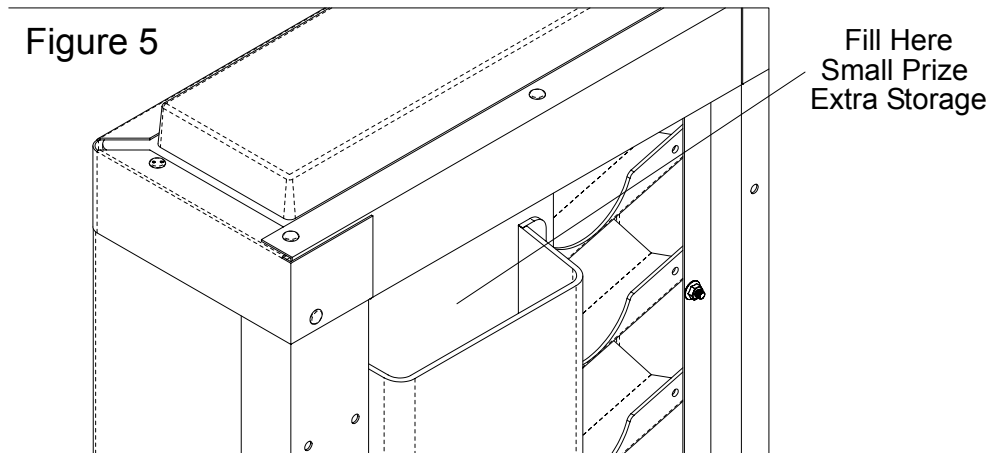

Figure 5

Figure 6

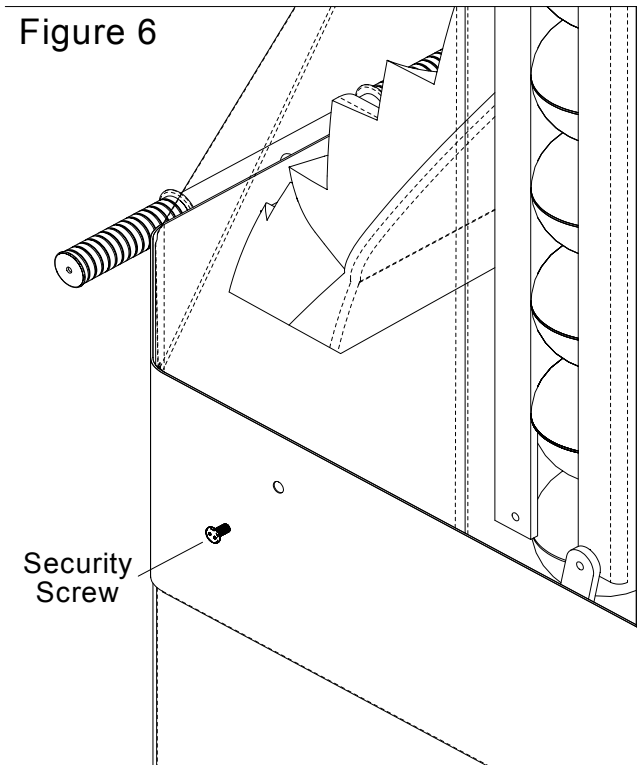

Figure 7a

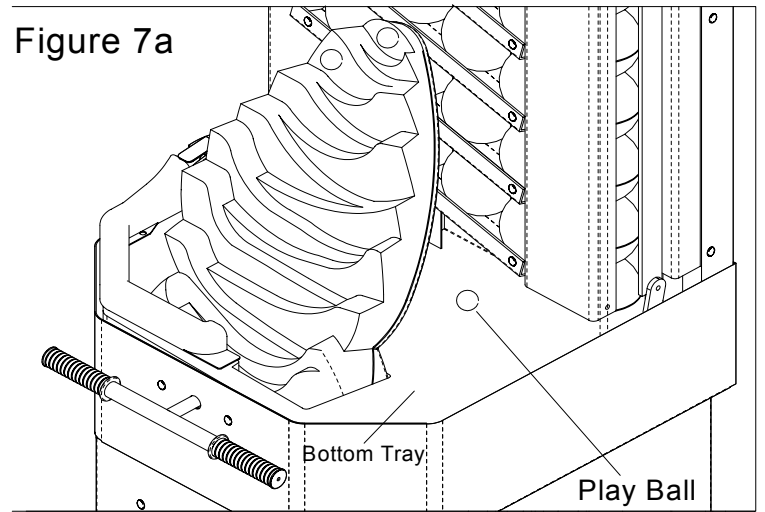

Figure 7b

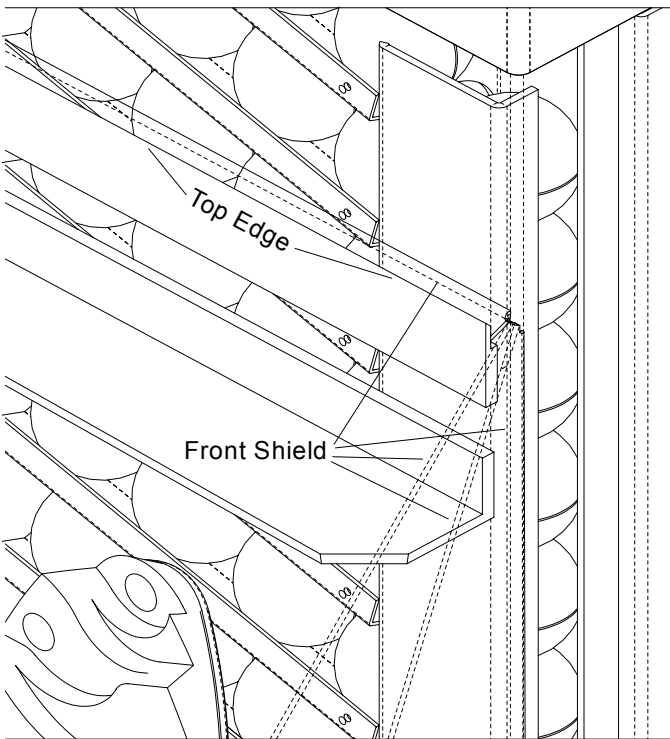
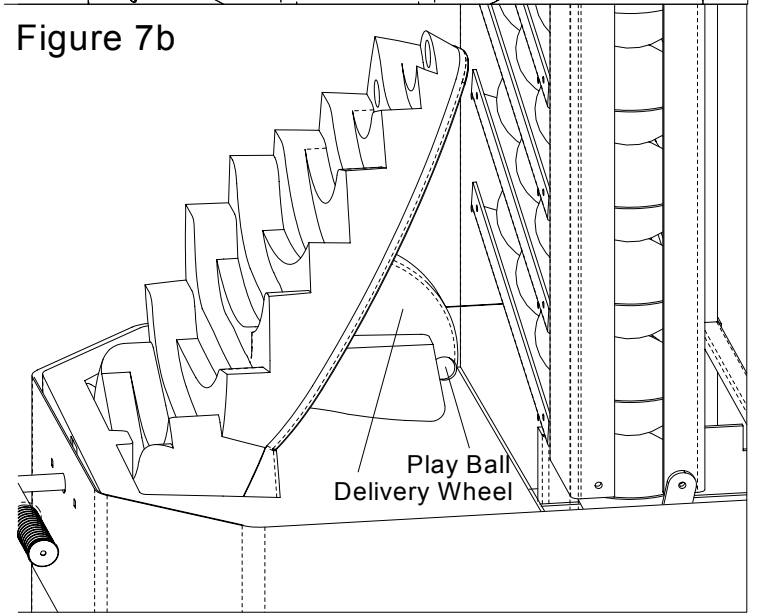

Figure 8

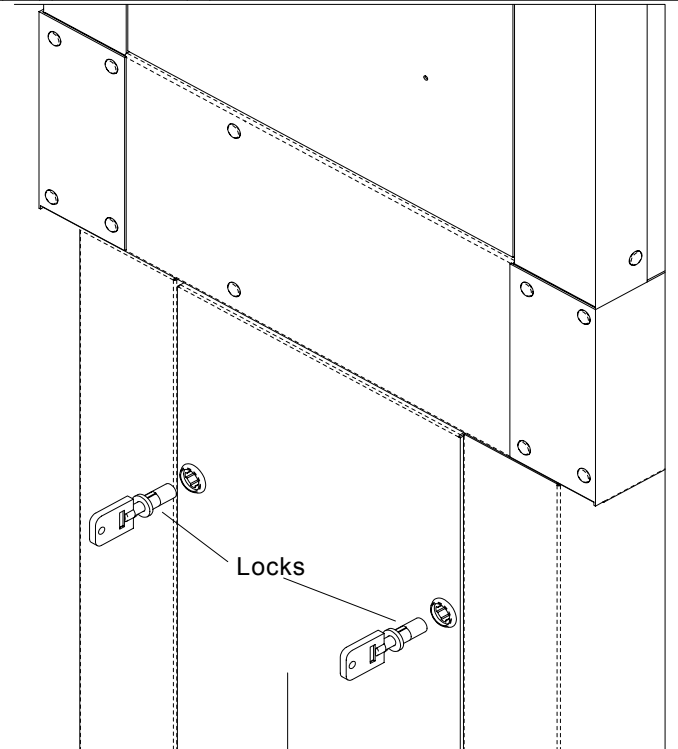
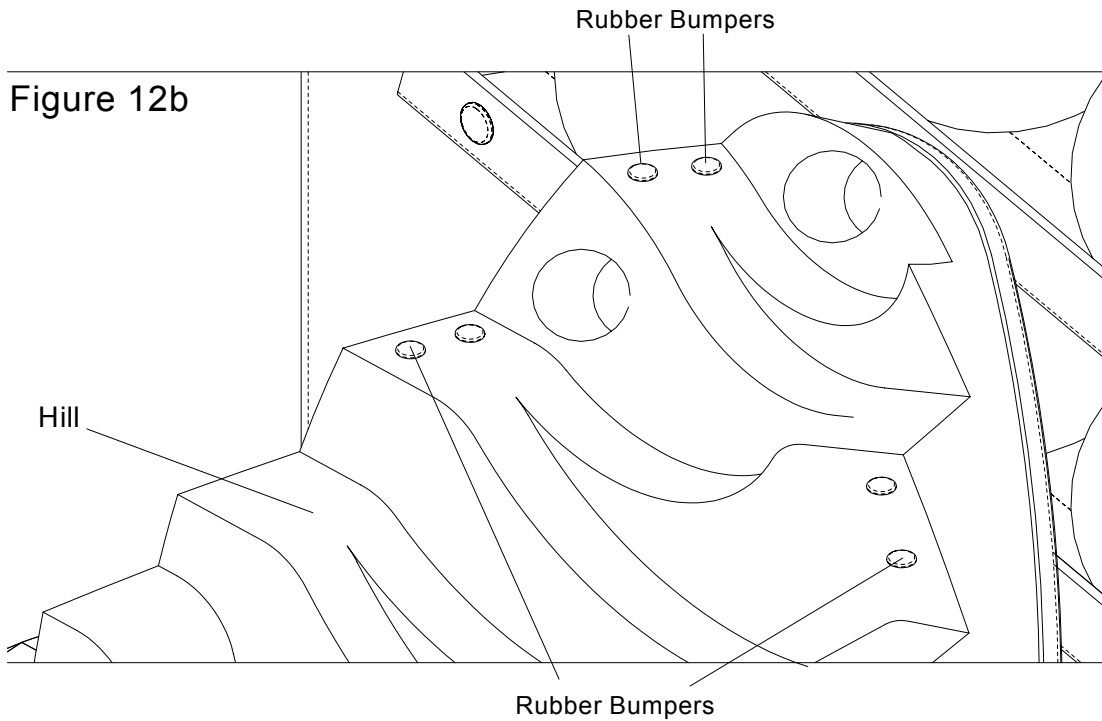
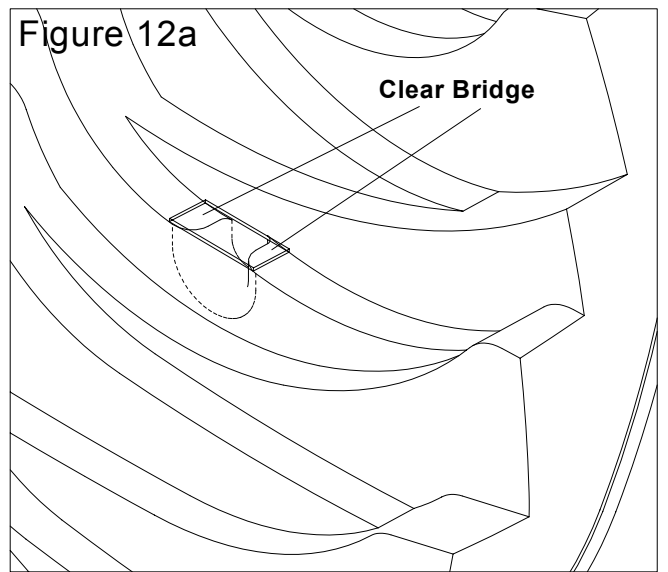
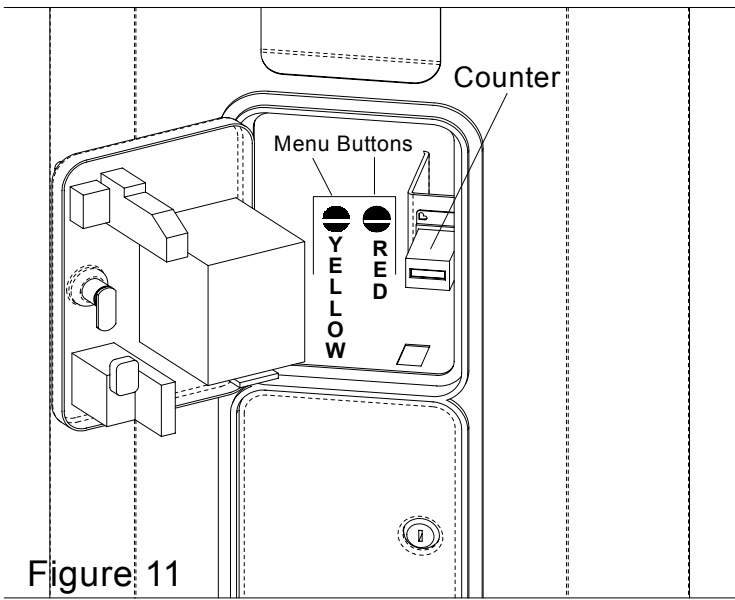
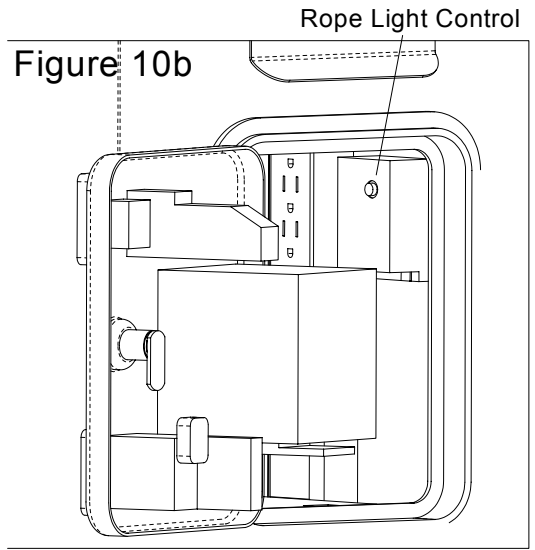
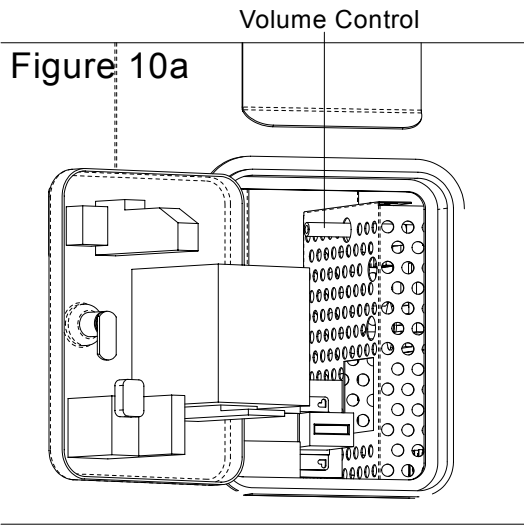

Figure 9

Lower Door



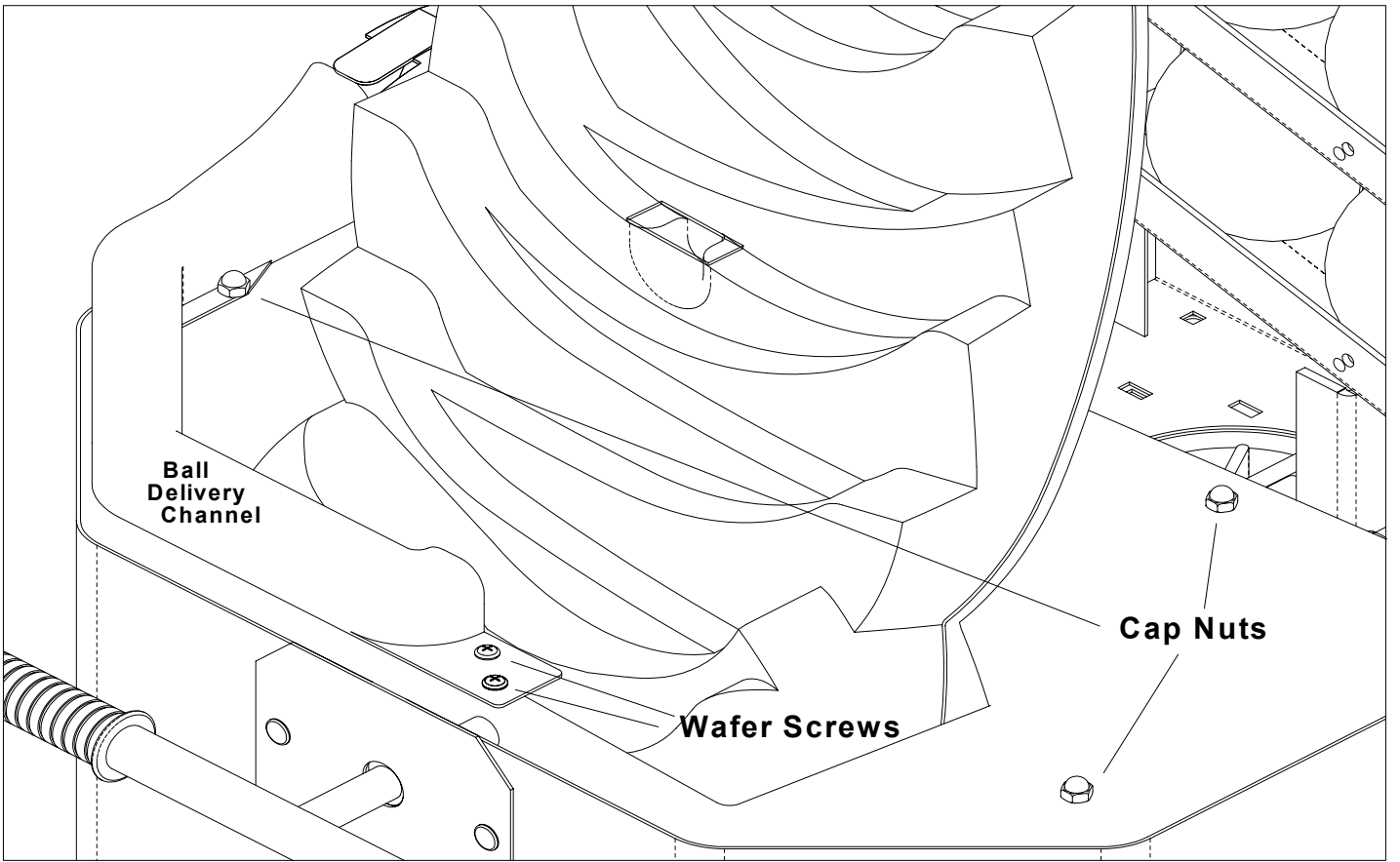

Figure 13

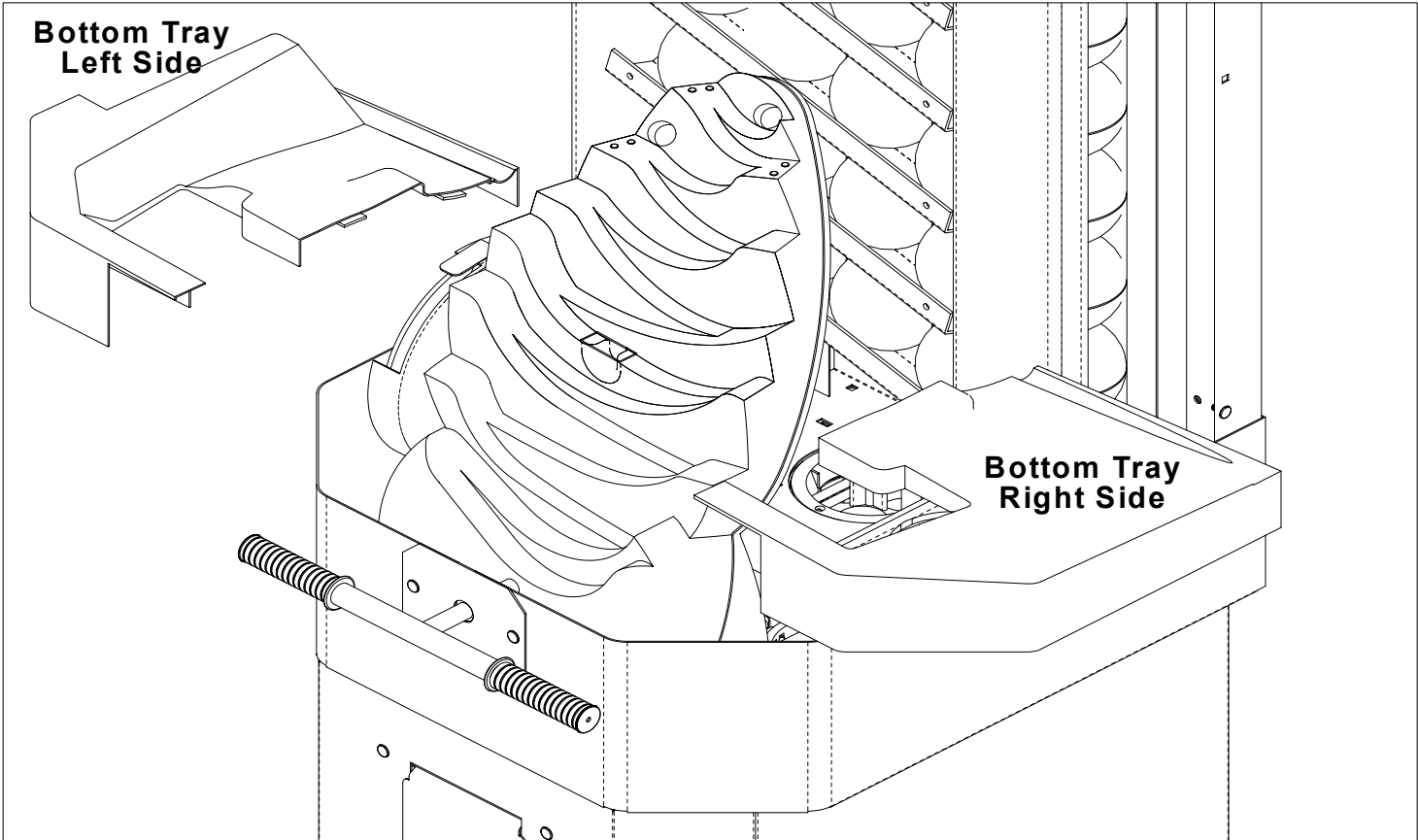

Figure 14

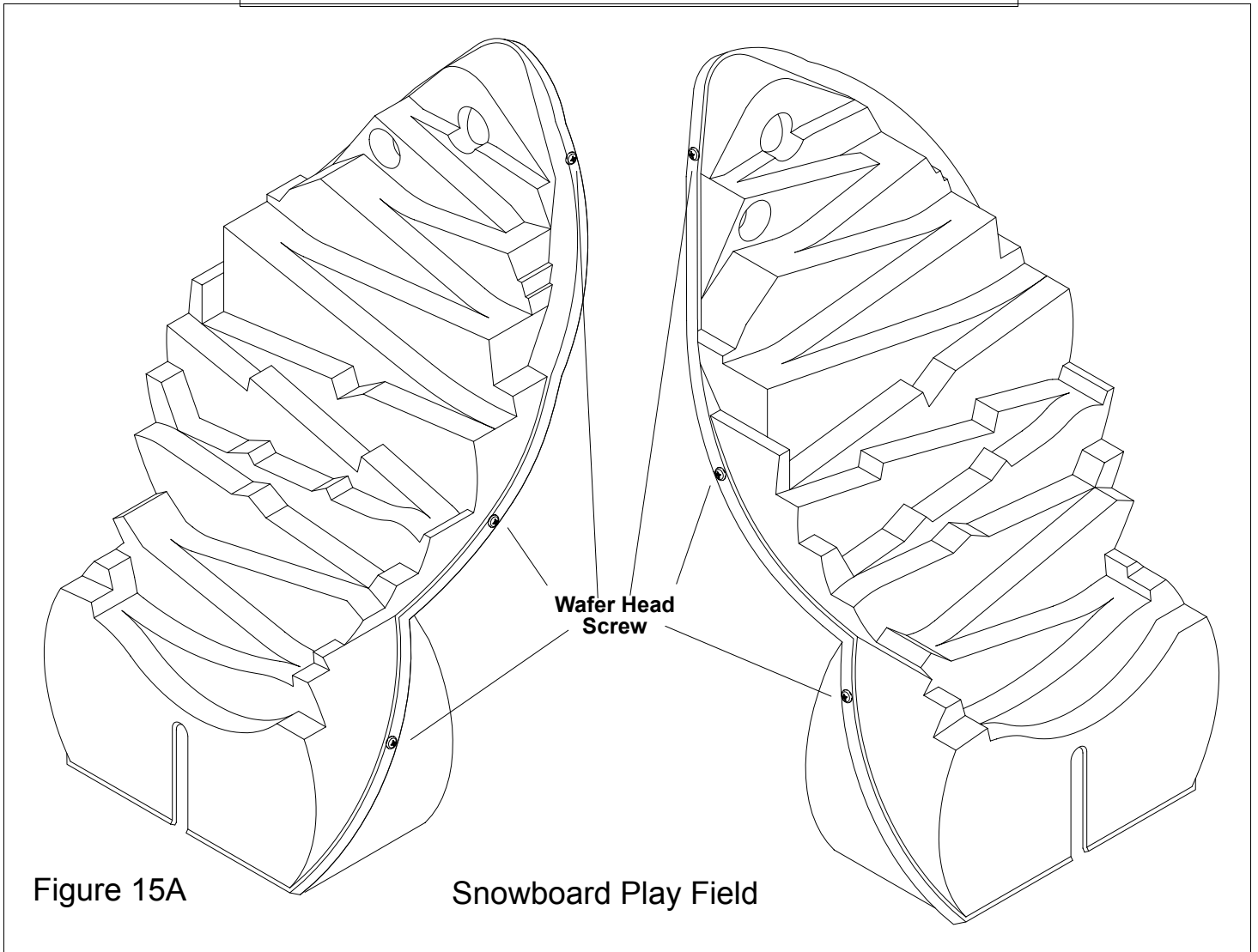
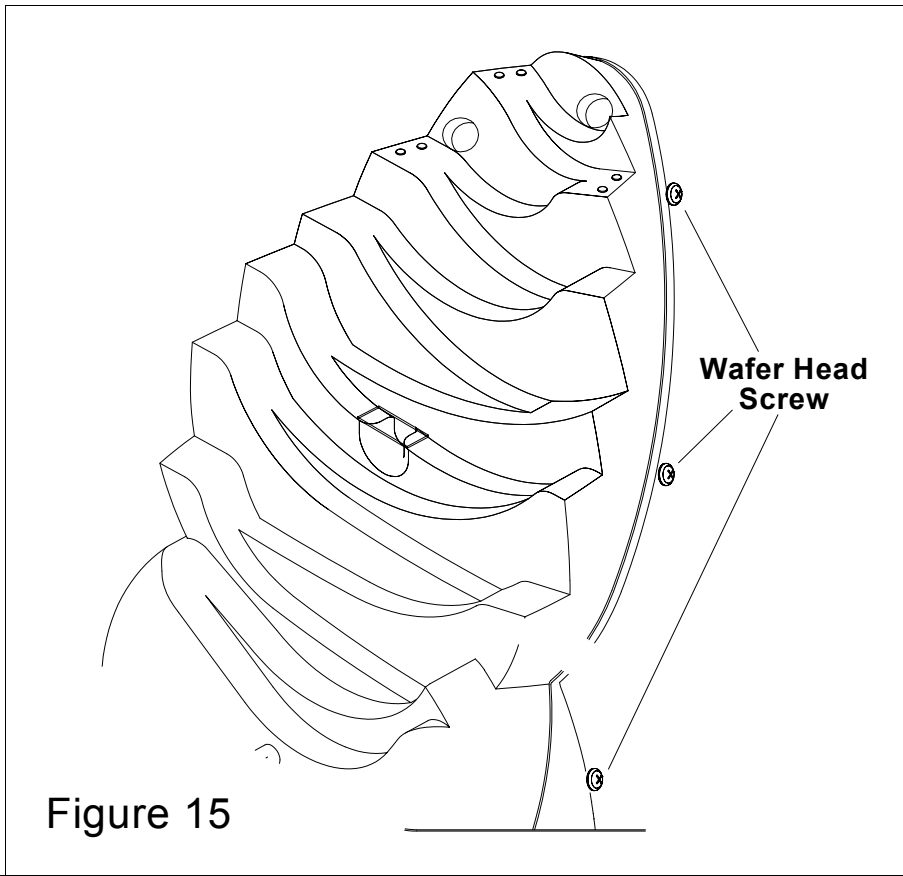

Figure 16

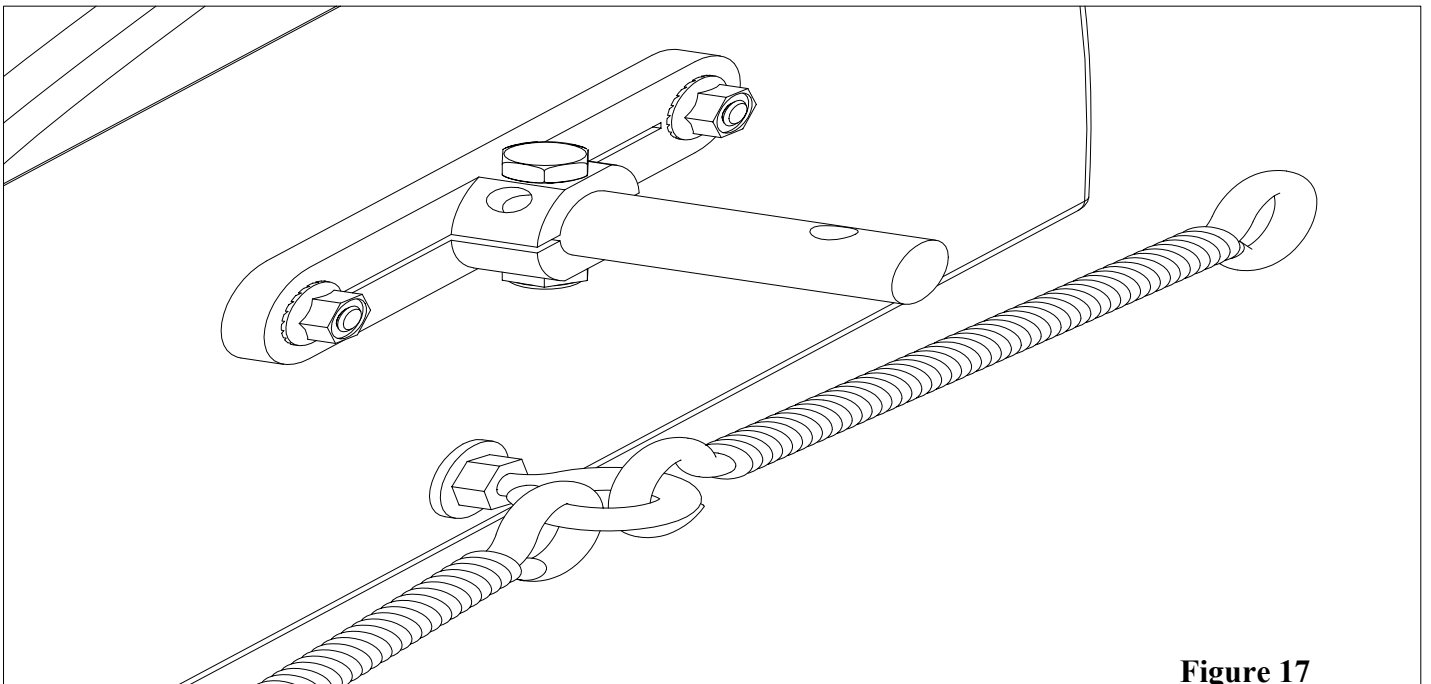
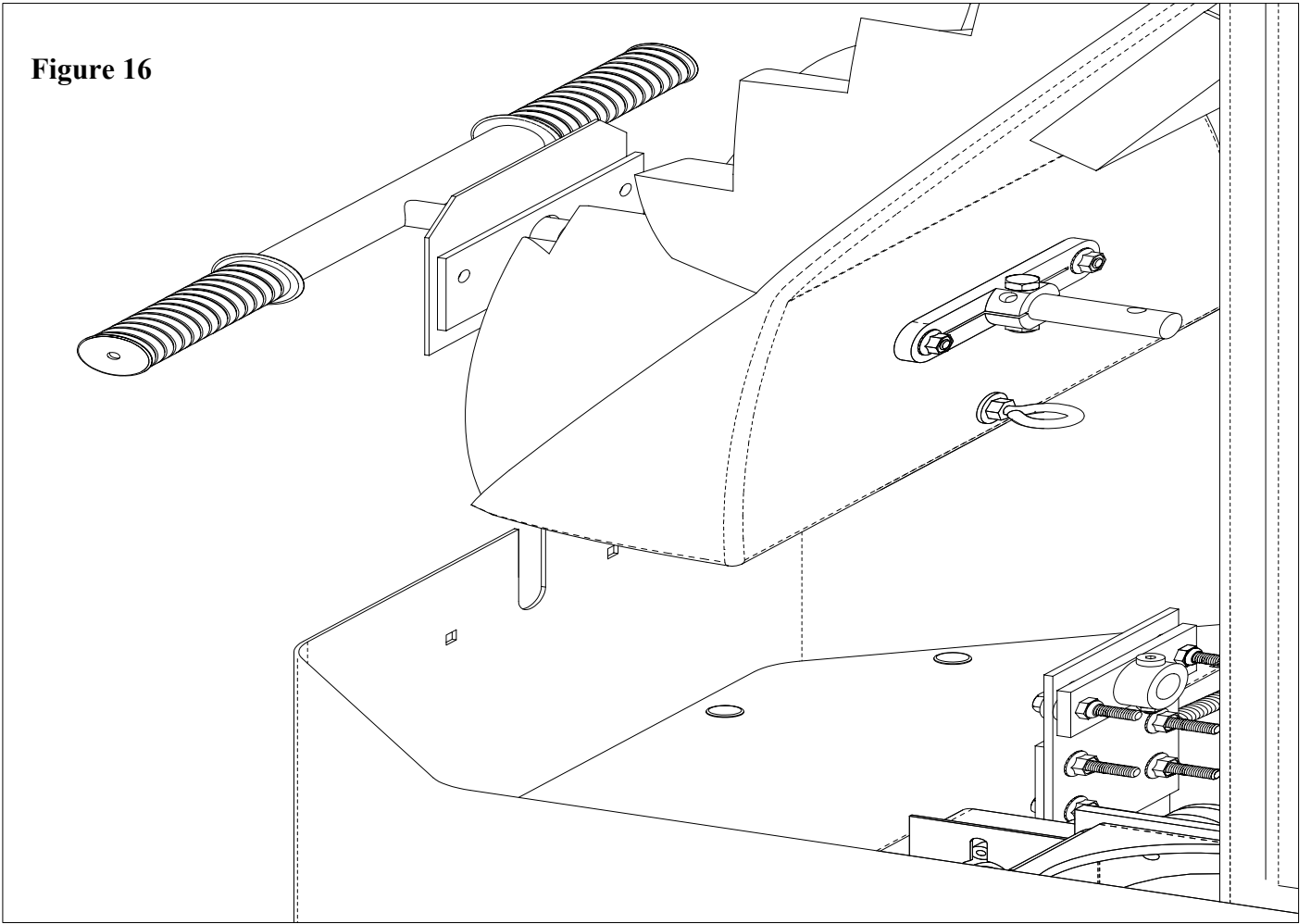
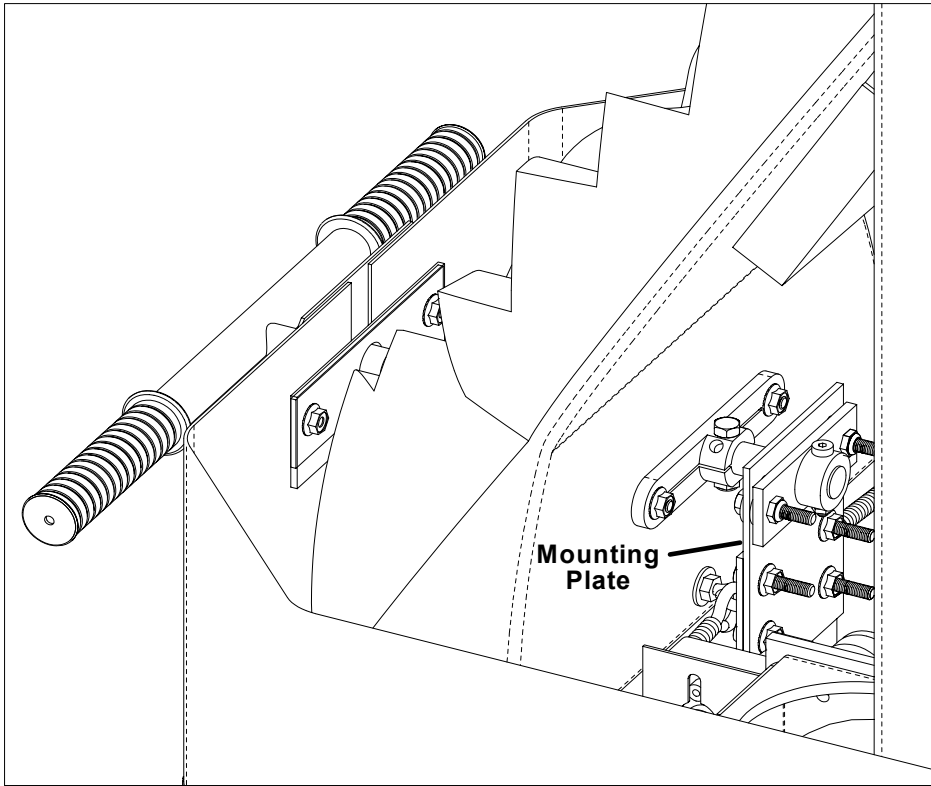

Figure 17

Figure 18

PLAY FIELD TILT INSTRUCTIONS



Remove the front shield of the Gravity Hill to expose the mountain. Then remove the cap nuts on the black bottom tray. Right side (as you face unit) removes easily. On left side, be gentle because of the micro-switches are mounted to the tray. Pull to the side. It is not necessary to disconnect wires from switches. (see figures 13 & 14).

At the rear of the mountain, locate the mounting plate as seen in figure 19. Loosen the lower 4 nuts in figure 20. Raise or lower mountain to obtain the desired degree of tilt. Re-tighten nuts and reassemble bottom trays and replaced front shield.

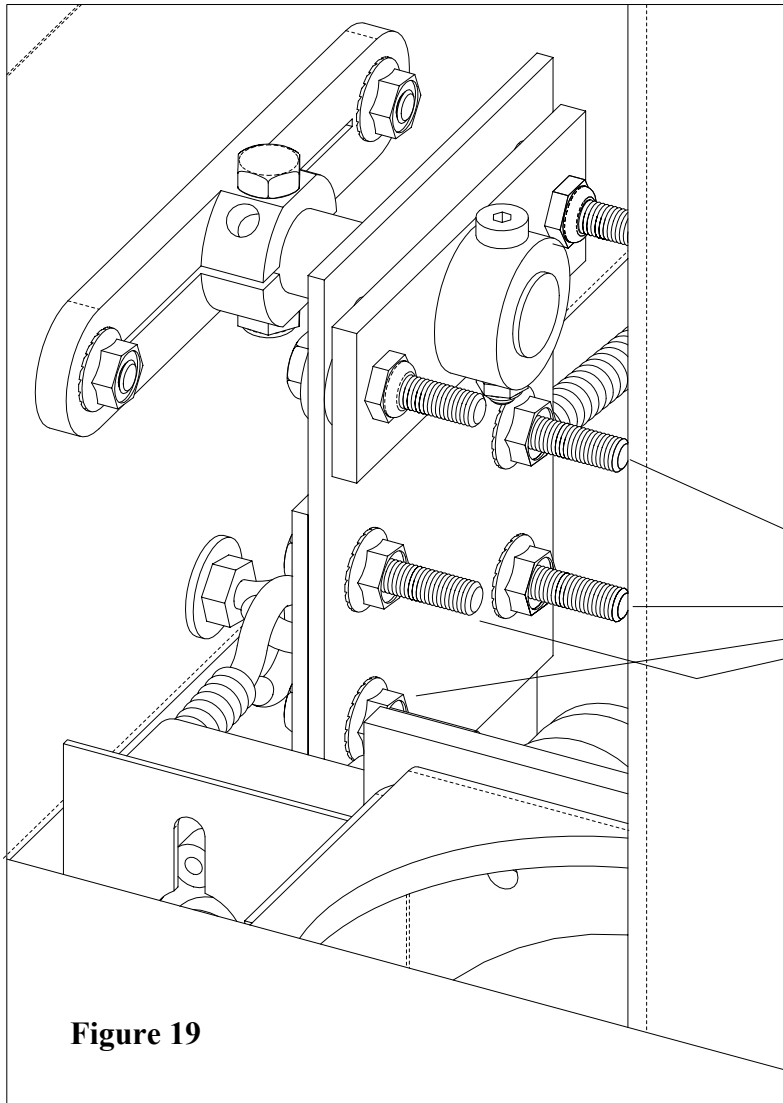

Loosen these 4 nuts and raise the mounting plate up or down to change the tilt of the mountain. Re-tighten nuts after desired angle is achieved.

Figure 19

Gravity Hill Board

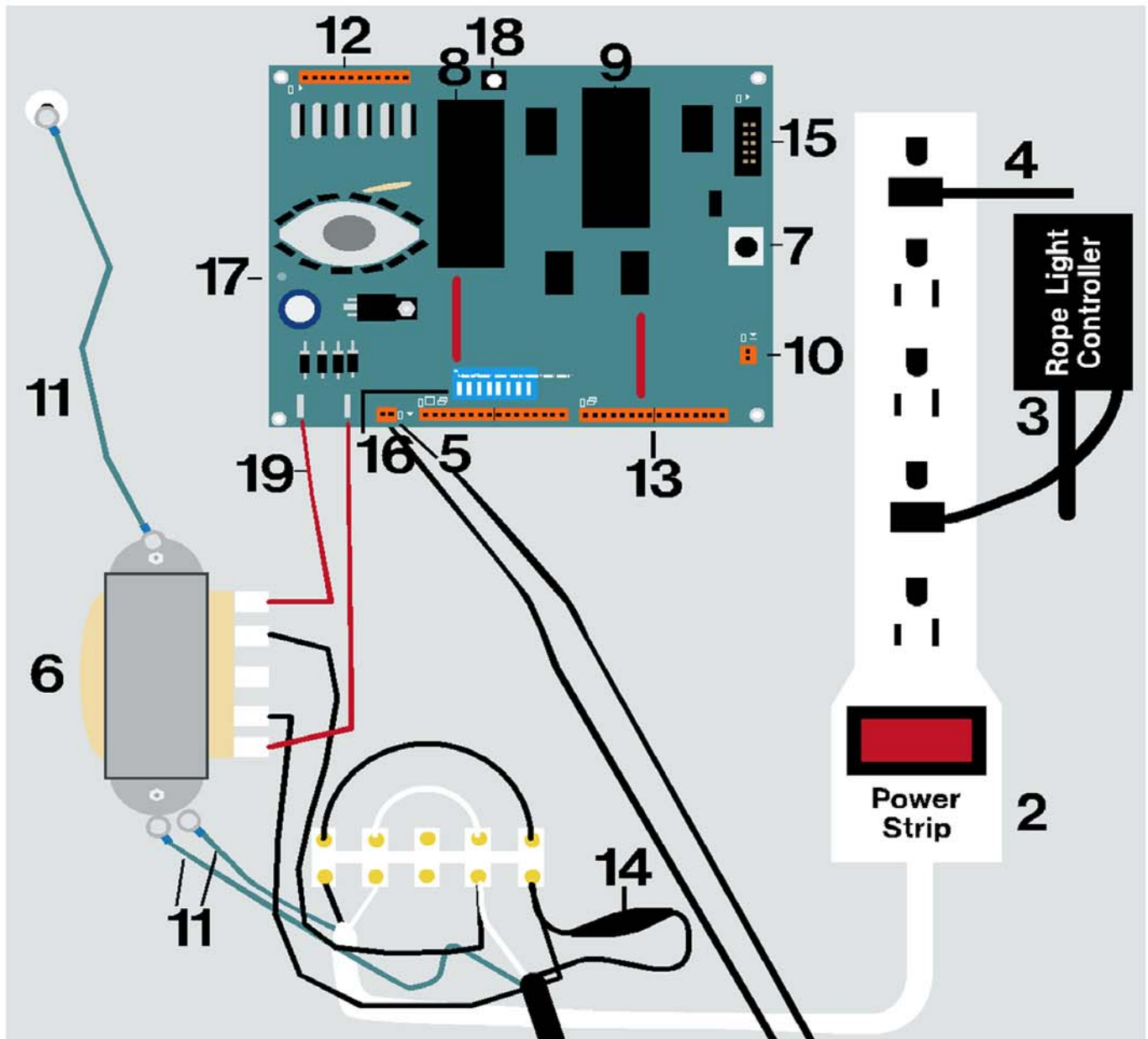

1. AC Power In
2. AC Power Strip
3. Rope Light Controller
Press Button to Change:
 1. Combination
 2. In Waves
 3. Sequential
 4. Slo Glo
 5. Chasing/Flash
 6. Slow Fade
 7. Twinkle/Flash
 8. Steady On
4. Fluorescent Light Plug
5. Non-Resettable Counter
6. Transformer
7. Volume Control
Up--Clockwise
Down--Counter Clockwise
8. Processor Chip
9. Eprom/Music Chip
10. Speaker Out
11. Ground Wires
12. 12 Volt Outputs
13. 12 Volt Inputs
14. AC In-Line Fuse
15. Time & Credit Display
16. Dip Switches
17. Power On Light
18. Attract Music Selector
19. AC Power in (12Volt)

Circuit Board with new wire harness

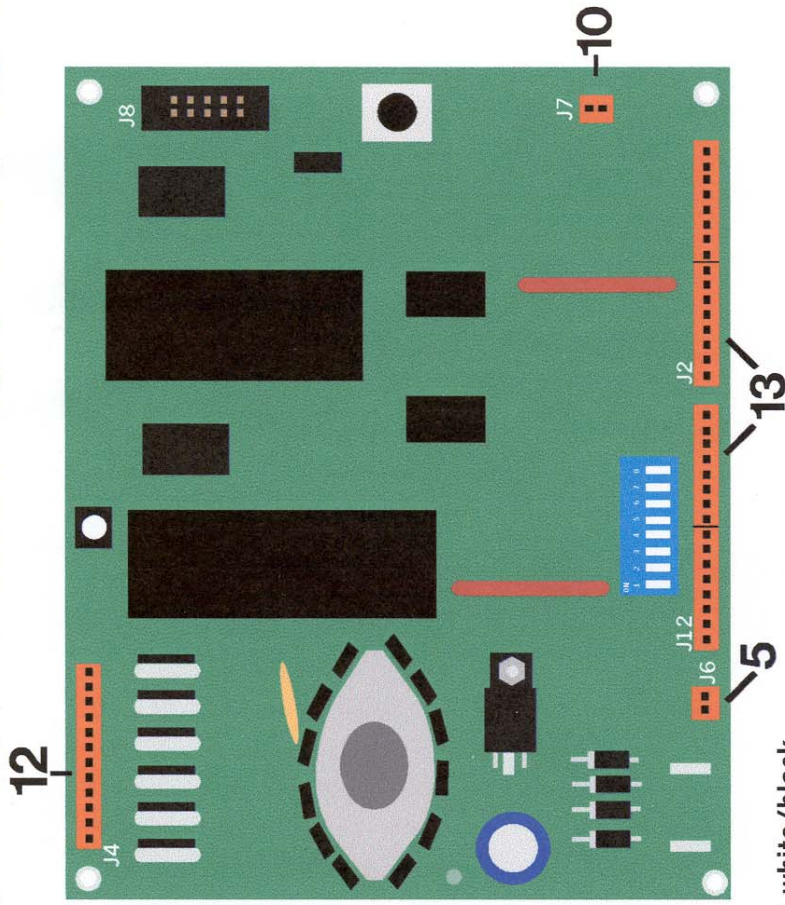

- 5. J6, Counter, white & white/black
- 10. J7, Speaker Out, Wire #15, white & brown/white
- 12. J4, 12 Volt Outputs (left to right)

Not Used, Wire #9

Not Used, Wire #10

Game Ball Lift Motor, Wire #11, white & green/white

Small Prize Motor, Wire #12, white & yellow/white

Grand Prize Motor, Wire #13, white & orange/white

Not Used, Wire #14

- 13. J12, 12 Volt Inputs (left to right)

Not Used

Not Used

Not Used

Not Used

Not Used

Dual Coin Mech, Wire #16

Display, Menu Button #1, Wire #17, white & green/white

Display, Menu Button #2, Wire #18, white & red/white

- J2 (left to right)

Coin Acceptor, Wire #1, white & violet

Grand Prize Dispense, Wire #2, white & blue

Bill Acceptor, Wire #3, white & green

Small Prize Dispense, Wire #4, white & yellow

Exit/Game Stop, Wire #5, white & orange

Ball Lift Motor Stop Switch, Wire #6, white & red

Small Prize Motor Off, Wire #7, white & brown

Grand Prize Motor Off, Wire #8, white & black

Circuit Board

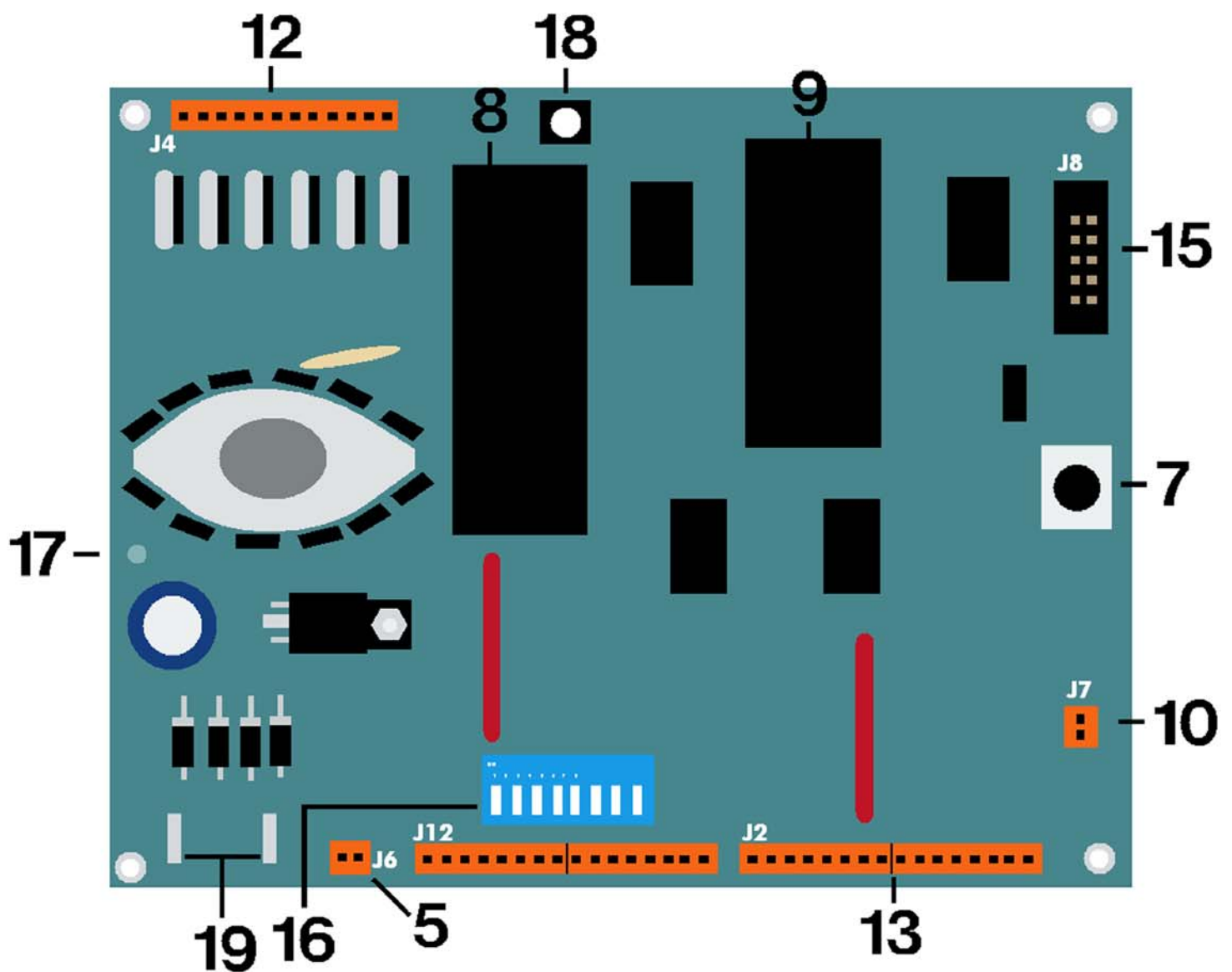

- 10. J7, Speaker Out, Wire #15
- 12. J4, 12 Volt Outputs (left to right)
 - Not Used, Wire #9
 - Not Used, Wire #10
 - Game Ball Lift Motor, Wire #11
 - Small Prize Motor, Wire #12
 - Grand Prize Motor, Wire #13
 - Not Used, Wire #14
- 13. J12, 12 Volt Inputs (left to right)
 - Not Used
 - Not Used
 - Not Used
 - Not Used
 - Not Used
 - Dual Coin Mech, Wire #16
 - Display, Menu Button #1, Wire #17
 - Display, Menu Button #2, Wire #18

- J2 (left to right)
 - Coin Acceptor, Wire #1
 - Grand Prize Dispense, Wire #2
 - Bill Acceptor, Wire #3
 - Small Prize Dispense, Wire #4
 - Exit / Game Stop, Wire #5
 - Ball Lift Motor Stop Switch, Wire #6
 - Small Prize Motor Off, Wire #7
 - Grand Prize Motor Off, Wire #8
- 15. Time & Credit Display
- 16. Dip Switches, All Always Off
- 17. Power on Light
- 18. Atract Music Selector
- 19. AC Power in (12 Volt)

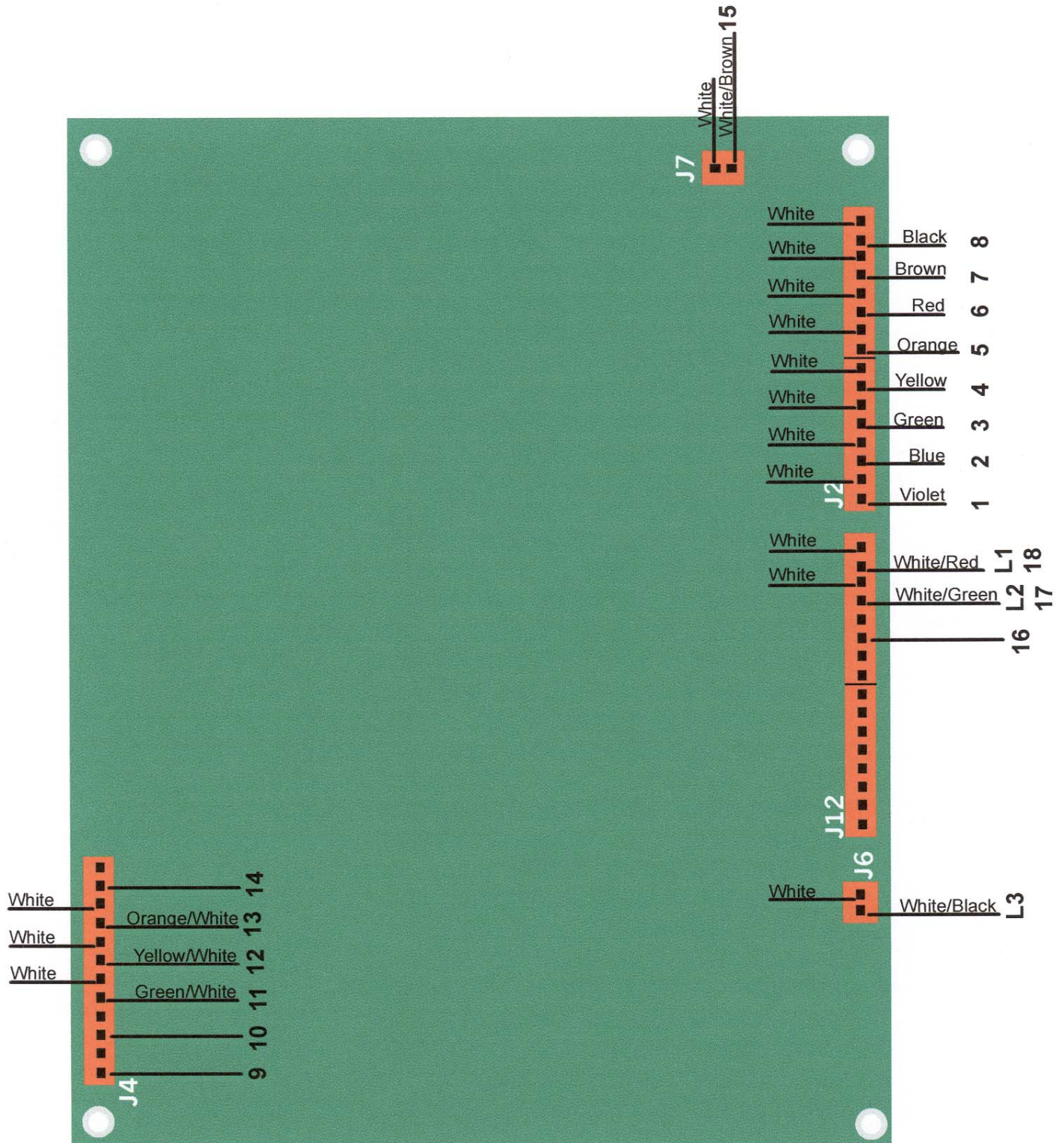

J2 Wire #

- 1. Coin Acceptor
- 2. Grand Prize Dispense
- 3. Bill Acceptor
- 4. Small Prize Dispense
- 5. Exit/Game Stop/Tilt
- 6. Ball Lift Motor Stop
- 7. Small Prize Motor Off
- 8. Grand Prize Motor Off

J4 Wire #

- 9. Not Used
- 10. Not Used
- 11. Game Ball Lift Motor
- 12. Small Prize Motor
- 13. Grand Prize Motor
- 14. Not Used

J6 Counter L3

- J7 Speaker #15
- J12 Wire #
- 16. Dual Coin Acceptor
- 17. L2 Display, Menu Button 1
- 18. L1 Display, Menu Button 2

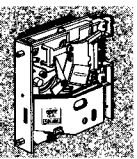

HAPP CONTROLS

Ultimech Operation Manual

Part Number 42-3079-00

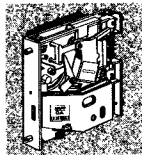

The Happ Controls \$.25 US Ultimech, one of the most popular \$.25 coin mechs in the amusement industry, is designed to detect and reject undesired coins and slugs while accepting virtually all genuine coins. The coins are discriminated by weight, diameter, thickness and metal content. Both brand new and greatly worn coins are equally accepted.

GENERAL

Each mech is individually adjusted at the factory to provide 99% acceptance of good coins and over 99% rejection of all known slugs. The Ultimech body is made from glass filled nylon providing strength, dimensional stability and long life. The cradle pins are made of brass and stainless steel. A steel plate is incorporated into the main plate opposite the magnet to enhance the magnetic field.

FEATURES

Each mech has special coin checking features including:

- A check for oversized or bent coins at the mech coin entry.
- Diameter and thickness check on the specially designed cradle (patent pending).
- Coin weight check by means of a counterweight on the cradle.
- Metal content check by a magnet used to generate eddy currents within a coin passing in front of it which slows the coin according to the metal content.
- Anti-stringing device which prevents a player from gaining credits by "stringing" the coin mech.
- Operating position: Upright within 2 degrees.

OPERATION

As the coin enters the mech, the entry slot restrictor checks it's size to prevent entry of grossly oversized coins. When the correct coin falls into the cradle, the cradle tips over to deliver the coin to the sizing lever and magnet.

If the coin is undersized, it will fall through the legs of the cradle and exit the mech through the reject side of the coin chute. If the coin is oversized in diameter or thickness, it will stop against the sizing lever. Underweight coins will not tip the cradle over. A good coin will be placed by the cradle on the rail.

A second thickness check is done as the coin passes between the gate assembly and the magnet holder to reject bent coins. Coins that are too thick will not pass between the magnet holder and the main plate and will be cleared when the reject lever is operated.

The coin then passes by the magnet. If the coin is not magnetic, the magnet will not slow the coin and it's speed when it leaves the rail will carry it past the accept side of the coin chute into the reject side. If a coin is ferromagnetic, such as a steel slug, it will stick to the magnet. The magnetic properties of a genuine US \$.25 coin will slow the coin just enough to allow it to fall off the rail into the accept side of the coin chute.

The arc of the falling coin is further tested by the separator to make the final discrimination between good and bad coins. Any of the above fault conditions can be cleared by a single operation of the reject lever. The bad coin will fall through the reject side of the coin chute and exit the mech.

ADJUSTMENT

All Ultimechs are adjusted at the factory for maximum performance and no adjustment should be necessary. If the mech has been disassembled or if more critical adjustments are desired, the following adjustment procedure is recommended (make sure that the mech is upright and level):

GATE

To adjust for slightly thicker coins or improve acceptance, turn the gate adjustment screw clockwise. To adjust for thinner coins or improve security, turn the screw counterclockwise.

MAGNET

Turn the magnet holder adjust screw counterclockwise until a coin dropped into the mech will not pass. Turn the screw clockwise until the coin just passes through. Turn the screw a further 1/2 turn clockwise for proper operation.

SEPARATOR

Loosen the screw holding the separator. Align the right edge of the separator with the innermost mark on the back of the main bezel. This is the standard adjustment and should be acceptable for most locations. As coins are dropped through, observe where the coin hits the separator. By moving the separator back and forth slightly, the desired acceptance of good versus bad coins can be obtained. Tighten the screw and retest to be sure of proper operation.

The entry restrictor, cradle and sizing lever are specially tooled and are not adjustable.

MAINTENANCE

The mech can be cleaned with any mild cleaner or even in a dishwasher. Rinse and dry completely. Make sure that the cradle and sizing lever move freely.

Do not use grease or oil on any part of the mech as this will attract dust and dirt which will slow down the coin and cause poor acceptance.

The magnet can be cleared of metal filings by guiding the edge of a screwdriver along the inside edges of the magnet holder. The filings will stick to the screwdriver.

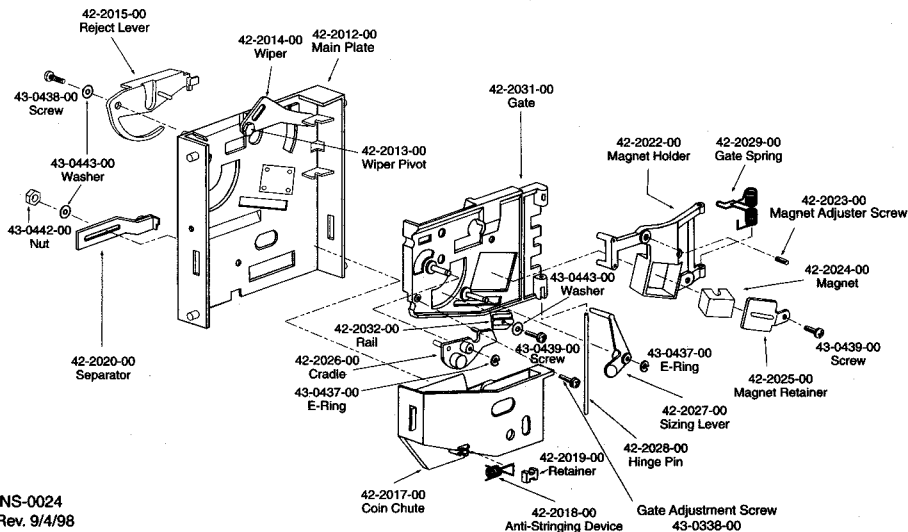

HAPP CONTROLS

OVER/UNDER UPSTACKER VALIDATOR DOOR

Validator Specifications

The Happ Controls Over/Under Upstacker Door is designed to utilize both the following validators from Mars and Ardac

Mars AE2411U3E & AE2411U5E

Ardac USA3 (88X5033) & DBA5 (88X5118)

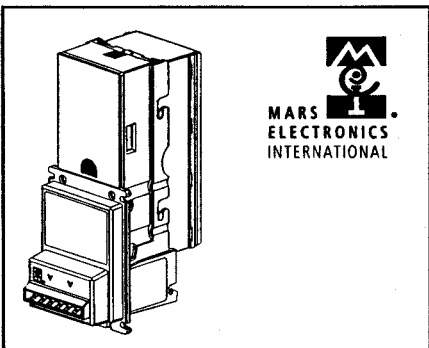
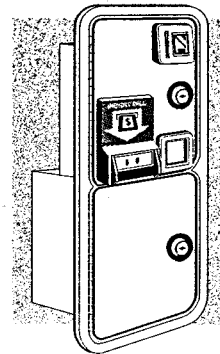
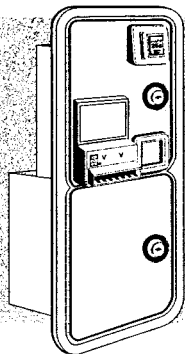

Mars

Model: AE2411U3E

Accepts \$1, \$5 bills (300 Bill Capacity Stacker)

Ref. Happ Controls P/N 42-1155-00

Model: AE2411U5E

Accepts \$1, \$5 bills (500 Bill Capacity Stacker)

Ref. Happ Controls P/N 42-6935-00

These standard Mars validators require some slight modification. Please follow the following steps using the supplied components to complete this modification.

- 1.) Remove and retain the four screws on the front of the Mars validator. (See Figure 1)
- 2.) Remove the original plastic bezel and the original steel mounting plate from the Mars validator (See Figure 1).
- 3.) Install the modified steel mounting plate 42-3136-00 (See Figure 2).
- 4.) Install the modified plastic bezel 42-7054-00 (See Figure 3). The angles on the steel mounting plate and the plastic bezel should line up with each other if both items are installed correctly.
- 5.) Insert and tighten the screws that were removed in Step #1.
- 6.) Apply "Factory Authorized Modification" label to validator.

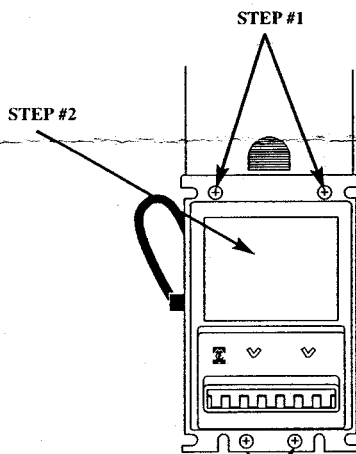

STEP #1
FIGURE 1
MARS SERIES 2000 VALIDATOR

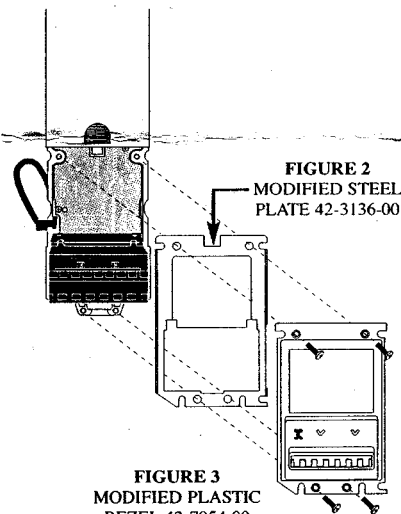

FIGURE 2
MODIFIED STEEL
PLATE 42-3136-00

FIGURE 3
MODIFIED PLASTIC
BEZEL 42-7054-00

Validator Installation Instructions:

1. Press upper mech retaining clip at location A and pull up until mech retaining clears mech. Repeat with bottom clip at location B.
2. Remove mech (C)
3. Remove and retain (4) #8-32 carriage bolts and (4) nuts at location D,E,F, and G
4. Remove blanking plate (H)
5. Insert (4) #8-32 carriage bolts retained in step #3 into locations D,E,F, and G (see fig 4)
6. Place validator on bolts at locations D,E,F, and G.
7. Use (4) #8-32 lock nuts retained in step #3 to secure validator to door at locations D,E,F, and G.
8. Tighten all four nuts until the validator is secured to the door.
9. Replace mech in mech holder.
10. Push down on upper mech retaining clip at location A until it snaps tight. Repeat with lower mech retaining clip at location B .

