



626F Exit Device Trim Installation Instructions

**For use with all Yale® 7000, 2100,
1800 and 1500 Series Exit Devices
(Wood and Metal Doors)**

Attention Installer

Any retrofit or other field modification to a fire rated opening can potentially impact the fire rating of the opening, and Yale Locks & Hardware makes no representations or warranties concerning what such impact may be in any specific situation. When retrofitting any portion of an existing fire rated opening, or specifying and installing a new fire-rated opening, please consult with a code specialist or local code official (Authority Having Jurisdiction) to ensure compliance with all applicable codes and ratings.

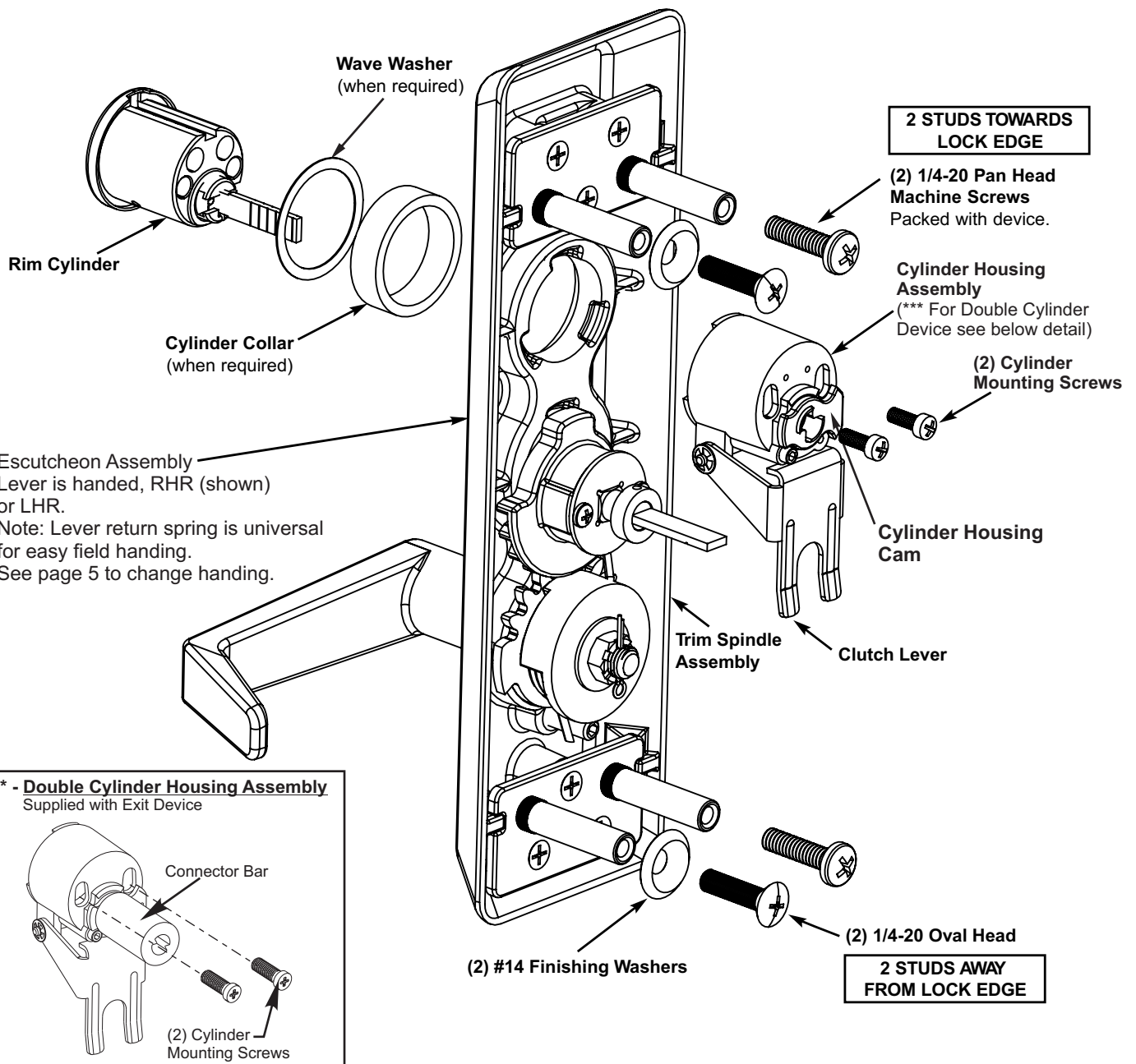

Installation Instructions

1. Assemble trim. See page 4 for components and instructions.
2. After marking door inside face for device location (Device Instructions) transfer Vertical Reference Centerline from inside to outside door face. Follow steps 2a and 2b below.
3. Transfer Horizontal Reference Centerline from inside to outside door face.
4. Align trim template and tape to outside door face. **CAUTION:** Office copiers and facsimile machines may change the size of a drawing and make the template inaccurate to use as a door marker. If this is not the original template packed with the trim, use only the dimensions written on the template to locate the holes on the door. (Do not use the template as a door marker)

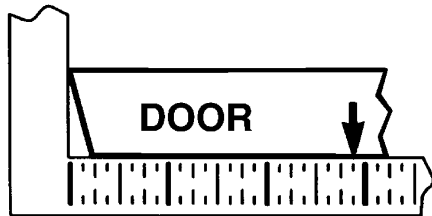

2a. MEASURE INSIDE LINE LOCATION.

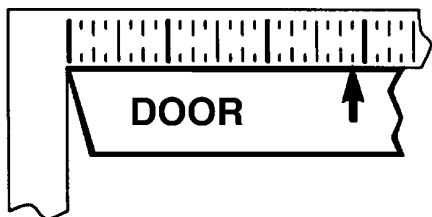

2b. TRANSFER DIMENSION TO OUTSIDE FACE.

5. Spot holes and prepare door for trim.
6. Mount trim to door thru holes "B". Fasten finger tight only with 2 screws and washers seating on door as shown in Figure 1.
7. Cut trim tailpiece as shown in Figure 2.
8. Seat device so that trim tailpiece penetrates cam slot as shown in Figure 1. Continue as shown in device instructions.

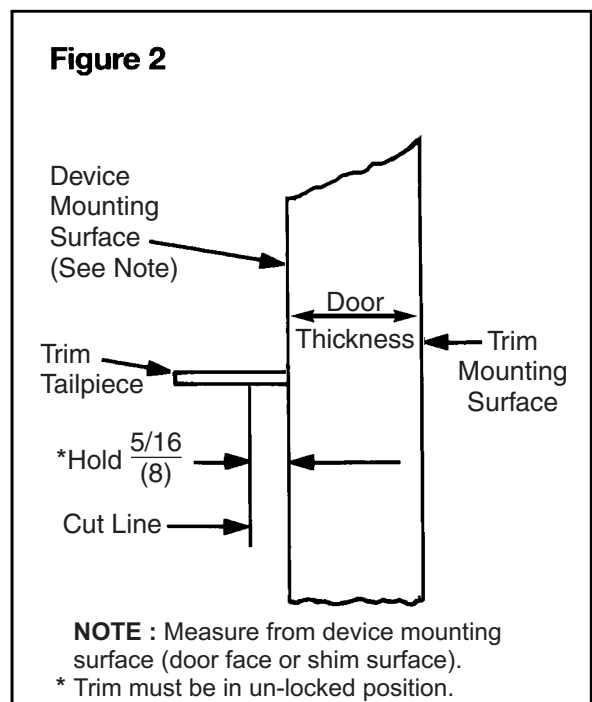
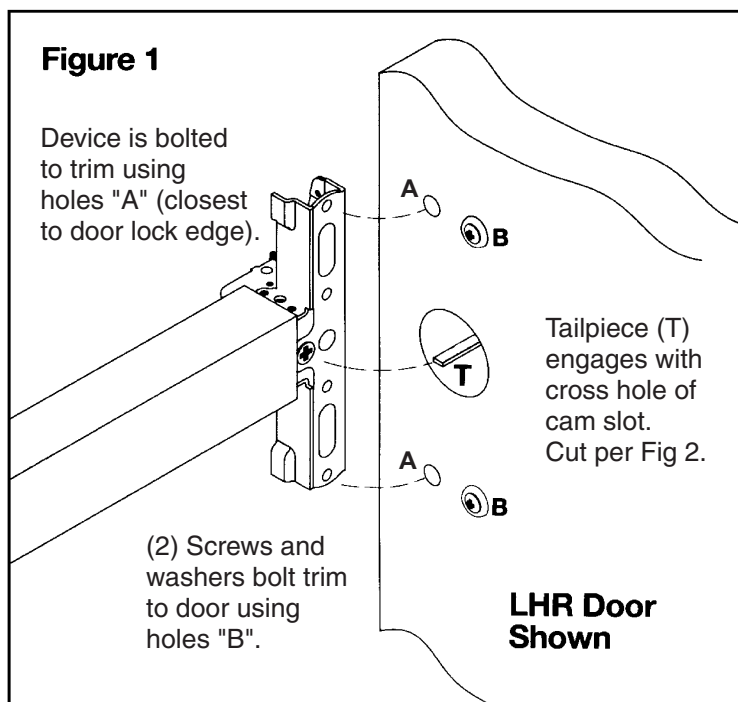

Outside Door Face

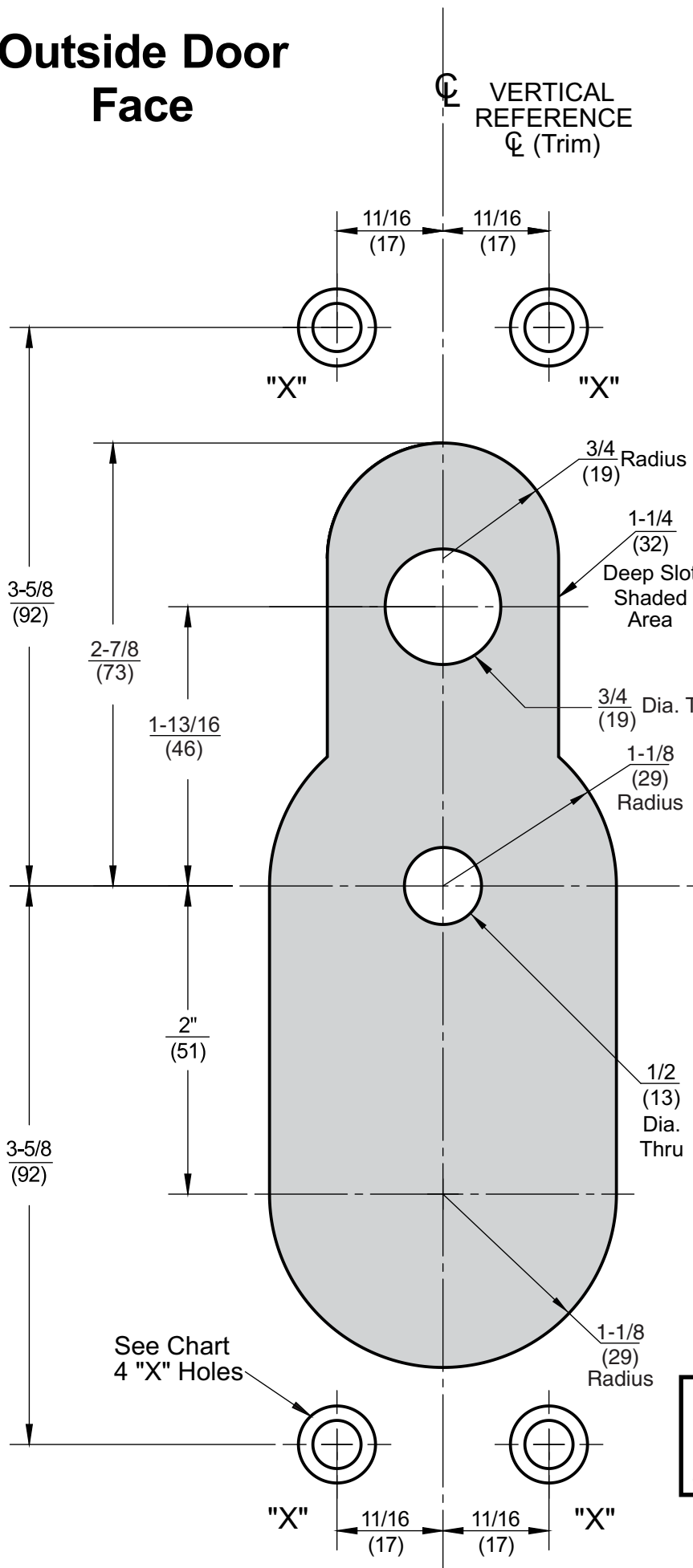

Trim Template

HOLES MARKED "X" (4 Places)	
METAL DOORS:	
Inside Face	5/16" (8) Dia.
Outside Face	1/2" (13) Dia.
WOOD DOORS:	
	1/2" (13) Dia. Thru

Dimensions given in $\frac{\text{Inches}}{\text{(mm)}}$

Trim Assembly Instructions

- 1. Check cylinder components.**
NOTE: Cylinders longer than 1-1/4" (32) will require collars.
 Refer to Yale® cylinder collar chart, below.
- 2. When required, cut cylinder tailpiece.**
- 3. Assemble cylinder.**
 Insert cylinder housing prongs into matching notches of escutcheon.
 Pass cylinder tailpiece thru cylinder collar (when required) and slot in cylinder housing cam.
 Fasten cylinder using (2) mounting screws.
DO NOT OVER TIGHTEN SCREWS.
- 4. Check cylinder action.**
 Rotate cylinder tailpiece to cam the clutch lever down.
 This depresses the trim spindle assembly which disengages the trim spindle from the lever handle, putting the trim in a free-wheeling, locked mode.
- 5. To Change Trim Function:**
 Rotate cam tip to down position (locked mode).
 Move function screw as shown.

Function Screw Position

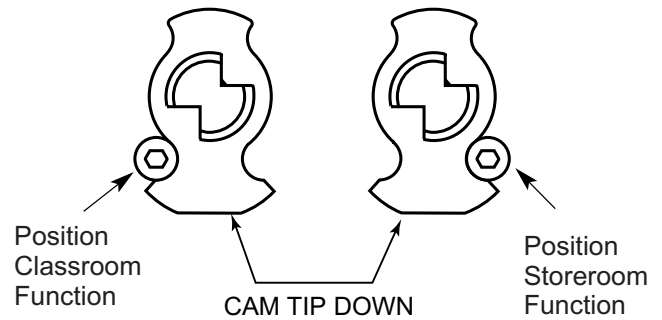

Yale® Cylinder Collar Chart	
Cylinder Length	Collar
1-1/8" (29)	None
1-1/4" (32)	None
1-1/2" (38)	1765.250**

** Specify finish

How to Change Handing

626F, 627F, 628F, 690F and 691F Series Exit Device Trim

Left Hand Reverse Gear & Spring Orientation

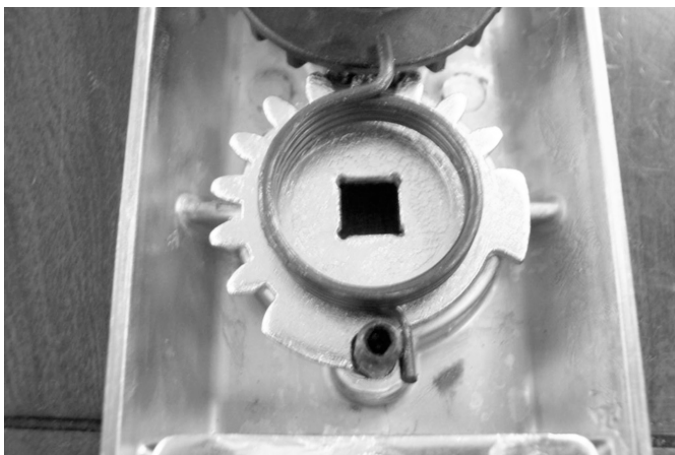

Right Hand Reverse Gear & Spring Orientation

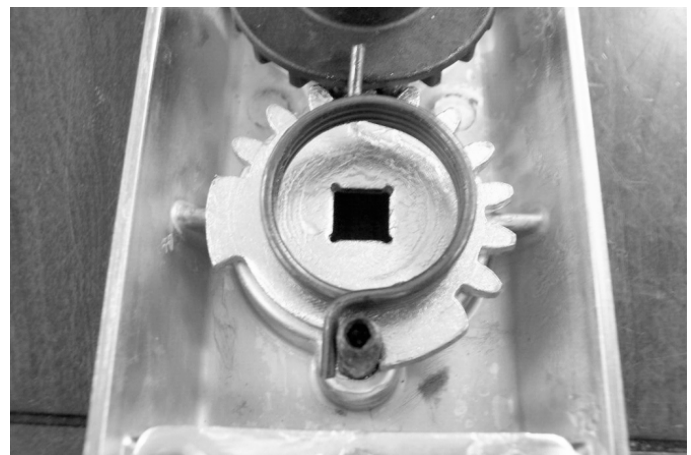

Notes:

1. During change ensure black driven gear does not rotate.
2. Please wear safety glasses and be aware of spring tension on spring hub upon removal and assembly.
3. Light lubrication is recommended under flat gear, white lithium grease can be used.

To Change Hands:

Tools Needed: Needle Nose pliers, Crescent wrench.

LEFT HAND REVERSE

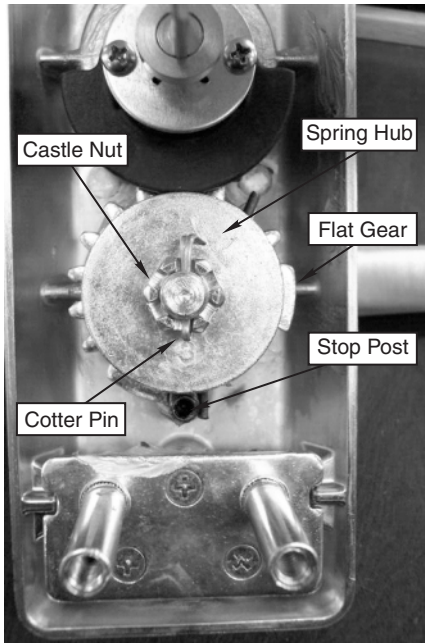

RIGHT HAND REVERSE

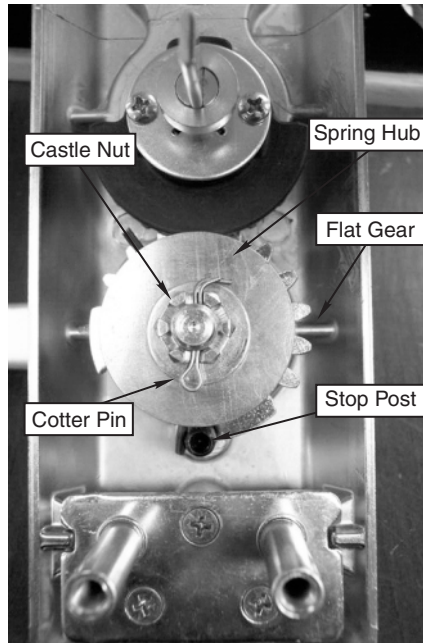

Notch for spring to engage for left hand reverse operation



Spring orientation for right hand reverse operation



1. Remove cotter pin.
2. Remove castle nut.
3. Remove washer.
4. Carefully pull up on spring hub to disengage spring.
5. Remove spring and note orientation.
6. Remove lever handle.
7. Pick-up flat gear, flip and orient stop on opposite side of stop post. See pictures for orientation.
8. Install spring upside down from original orientation and place spring leg on opposite side of stop post from original installation orientation. See pictures for orientation.
9. Install lever 180 degrees from original position.
10. Install spring hub with stamped number in the 6 o'clock position.
11. Rotate spring leg around with needle nose pliers to engage notch in spring hub, refer to pictures for reference position. Press down on spring hub to ensure complete engagement.
12. Install washer.
13. Install castle nut, do not over tighten, verify by insuring lever returns horizontally on its own.
14. Install cotter pin.

online literature and templates

For the latest information on Yale Locks & Hardware products, visit our website at: www.yalelocks.com

Click on the "Product Information" button to find:

- Catalogs
- Parts manuals
- Templates
- Specifications
- Installation instructions

Yale® customers can click on the ebusiness symbol  on the website to register for an ebusiness account to:

- Check the status of orders
 - Check availability of Quick-Ship items
 - Track your order and confirm delivery
 - Receive email notification of template changes
- And More...

Yale Locks & Hardware

Product Support Tel 800.438.1951 • www.yalelocks.com

Yale Locks & Hardware is a division of Yale Security Inc., an ASSA ABLOY Group company.

Yale® is a registered trademark of Yale Security Inc., an ASSA ABLOY Group company. Other products' brand names may be trademarks or registered trademarks of their respective owners and are mentioned for reference purposes only. These materials are protected under U.S. copyright laws. All contents current at time of publication. Yale Security Inc. reserves the right to change availability of any item in this catalog, its design, construction, and/or its materials.

Copyright © 2008, 2013, Yale Security Inc., an ASSA ABLOY Group company.

All rights reserved. Reproduction in whole or in part without the express written permission of Yale Security Inc. is prohibited.