

MANUAL DE MONTAGEM

ATENÇÃO:

- 1 - Ler atentamente todo o manual antes de iniciar a montagem do móvel.
- 2 - A montagem deve ser feita em uma superfície plana e limpa.
- 3 - Recomenda-se utilizar a embalagem do móvel para forrar e chão e assim não danificá-los

LIMPEZA E CONSERVAÇÃO:

A limpeza do móvel deve ser feita com utilização de pano umedecido com água, podendo conter uma pequena quantidade de álcool. Não utilize produtos abrasivos.

GARANTIA:

90 dias para defeitos de fabricação.

Quantidade de pessoas
necessárias para montar o
móvel

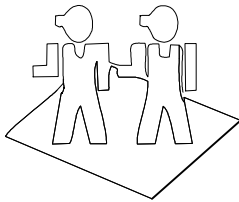





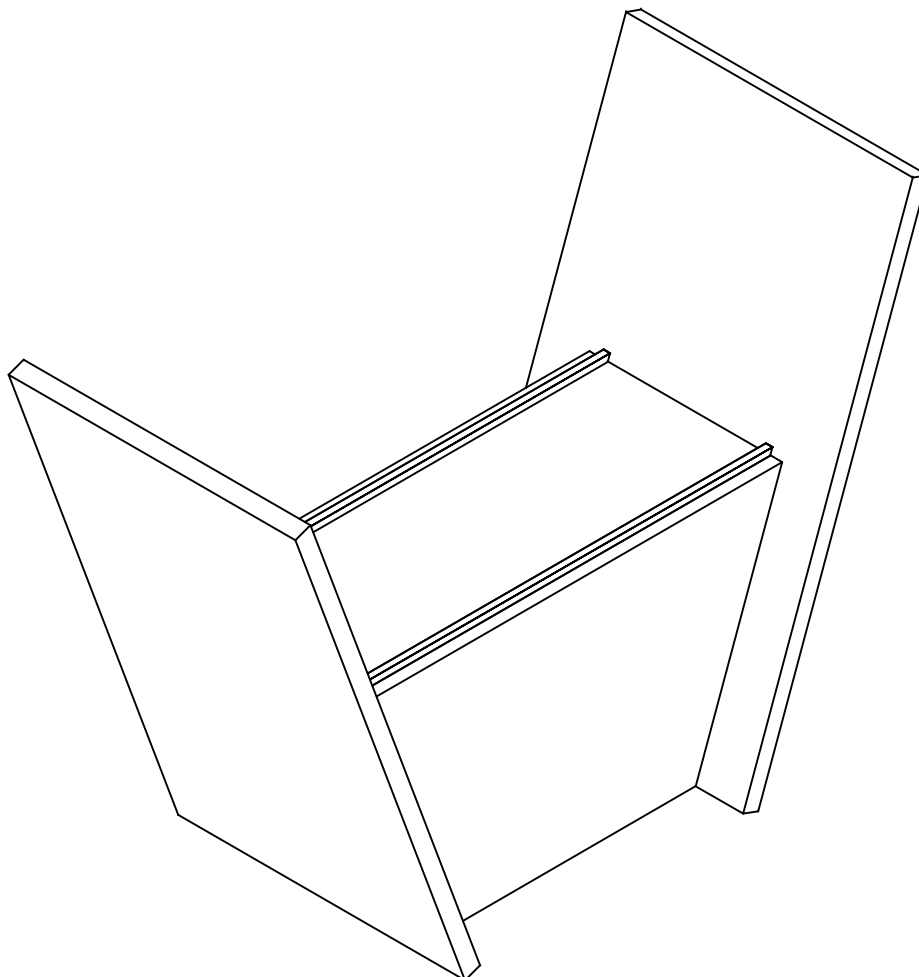
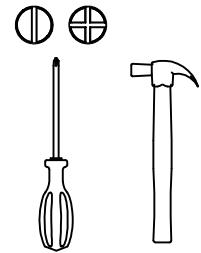

Tempo necessário para a
montagem: 1h



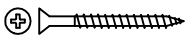



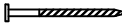
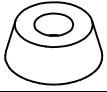

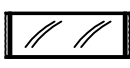
Ferramentas necessárias



Lista de peças						
Código de assistência	Descrição	Quant.	Compr. (mm)	Larg. (mm)	Espes. (mm)	Caixa/ volume
01	Laterais	2	773	447	25	A
02	Tampo	1	679	264	18	A
03	Reforços	2	679	370	18	A

Ferragem			
	Código de assistência	Descrição	Quant.
A	226	 Parafuso chato 4,0x40 bicromatizado	4
B	4214	 Parafuso chato 3,5x14 cabeça rebaixada	8
C	85	 "L" de metal	4
D	1802	 Cavilha 6x30mm	12
E	149	 Pregão 13 x 15	4
F	1901	 Sapata deslizadora preta	4
G	58	 Etiqueta marca "Kappesberg"	1
H	41	 Cola branca em bisnaga (10g)	1

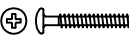
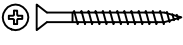
I	43510	 Suporte para tampo de vidro marrom	4
I	43524	 Suporte para tampo de vidro bege	4
J	9623	 Batente de silicone	4
K	43293	 Tapa furo adesivo pine 13mm	12
K	43687	 Tapa furo nogal estar 13mm	12
K	44669	 Tapa furo walnut estar 13mm	12
L	43314	 Tubo de mesa 685mm angular Rose	2
M	19730	 Parafuso maquina M4 X 20 cab. panela	4
N	89	 Parafuso chato 4,5x60 bicromatizado	8



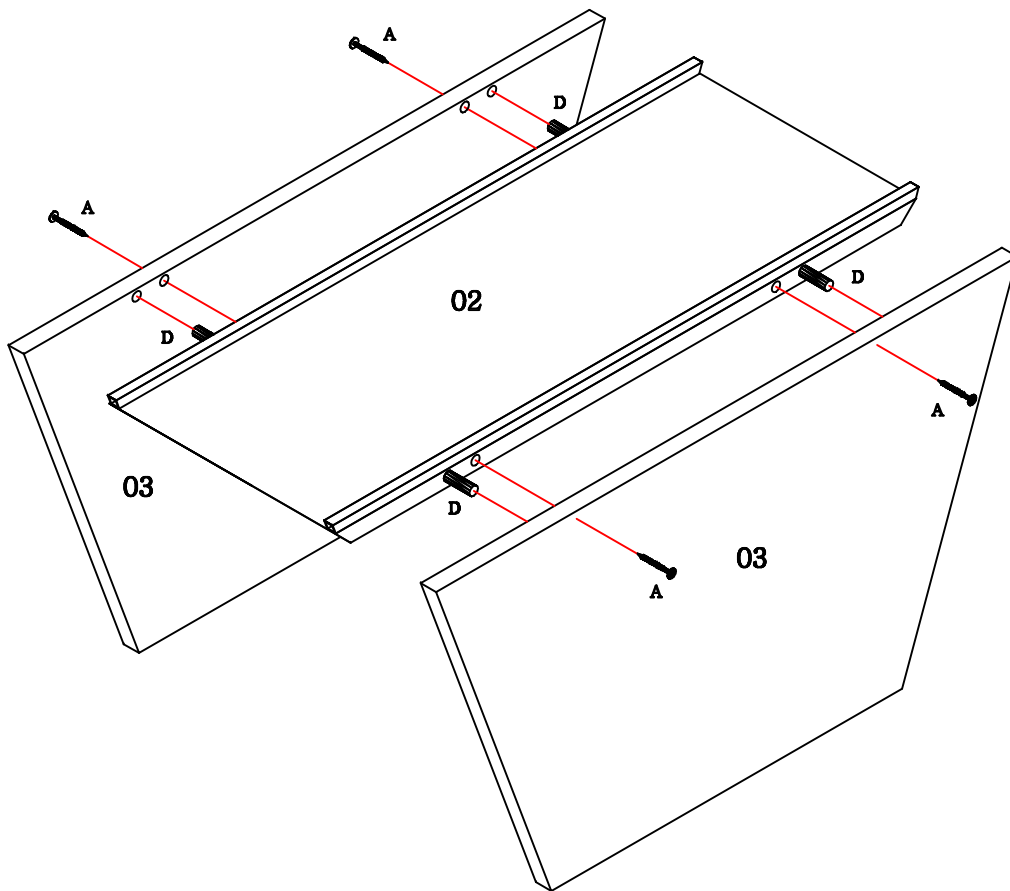
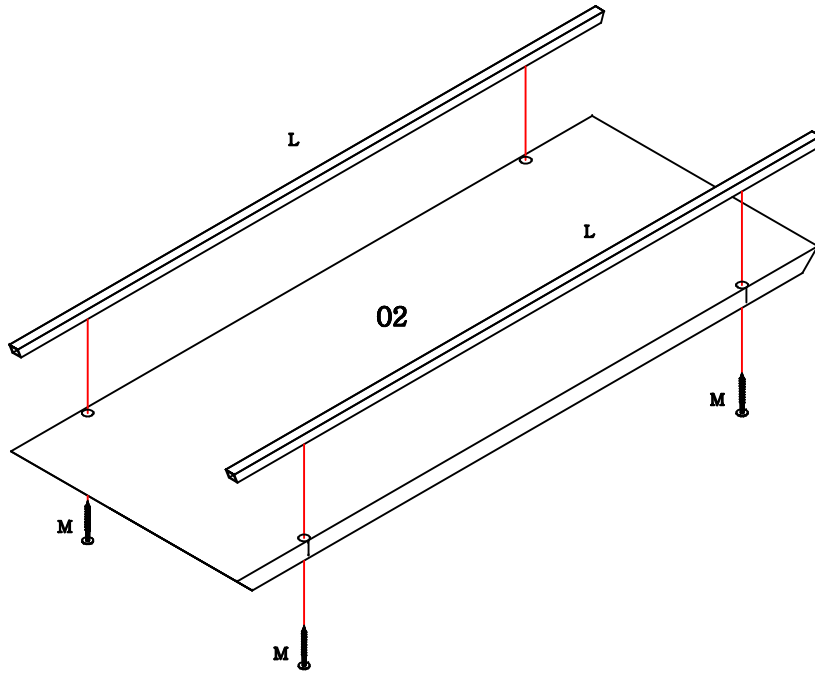

As sapatas "F" devem ser fixadas nas laterais "01" e "02" rentes ao limite externo do móvel.

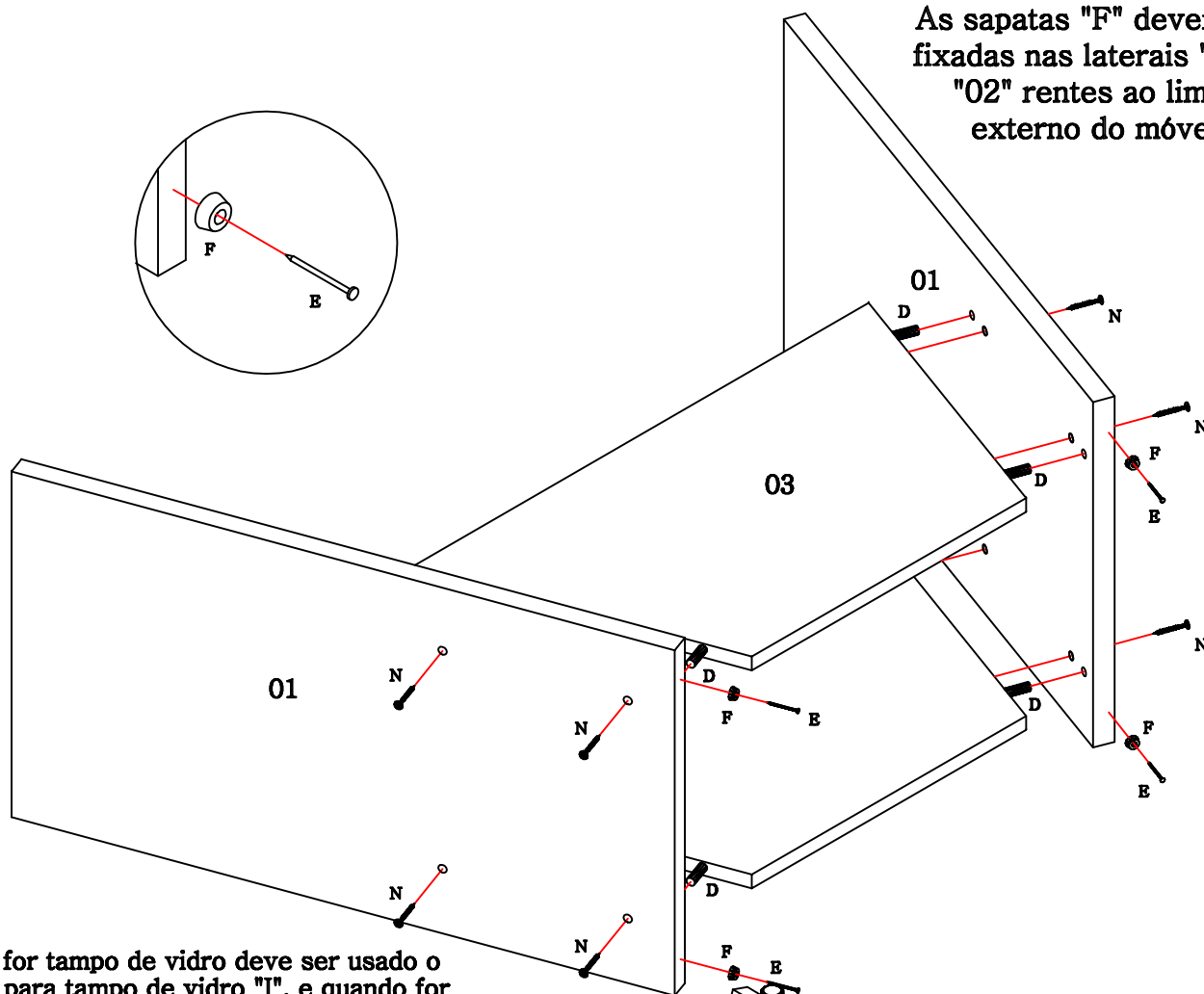

Quando for tampo de vidro deve ser usado o suporte para tampo de vidro "I", e quando for usado tampo de madeira usar o L de metal "C" com os parafusos "B".

