





HOT WATER AND HEATING

Beyond Expectations

With over 50 million Grundfos hot water or heating circulators already successfully installed around the world, you can be sure that you're in good company.

Since 1959, Grundfos has developed a series of pumps to suit every conceivable household hot water and heating need - and we continue to be the professionals' first choice pump supplier around the globe.

Add convenience and save money with heating and hot water circulation solutions from Grundfos. There are solutions for both new and existing homes.

APPLICATIONS

Home booster: the pump increases the pressure so that the required pressure is available at showers, taps etc for domestic water. The pump is used in open systems and can be connected directly to the water main.

FEATURES

- Easy installation
- Low noise
- Water-cooled system
- Leakage free
- Energy saving
- Space intelligent

CONSTRUCTION

- Stainless steel body
- Built in flow switch



TECHNICAL FEATURES

Model		UPA15-90N
Voltage	V	240
P1	W	120
In	A	0.48
Enclosure & Insulation class		IP42/H
Maximum liquid temperature	°C	90
Recommended minimum suction Head	mm	850
Port to port dimension	mm	160
Union set provided		¾”M
Net weight	kg	2.50

2 YEAR WARRANTY



PERFORMANCE

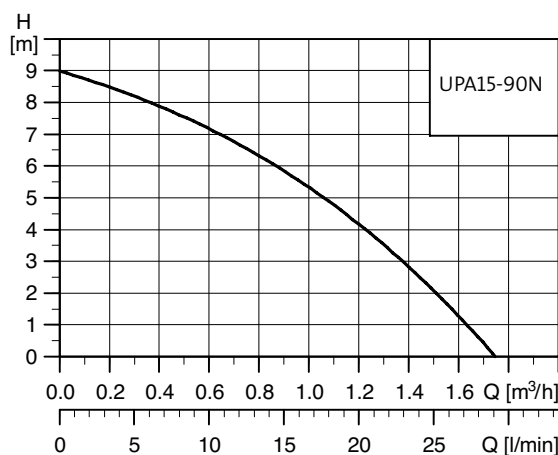

INSTALLATION

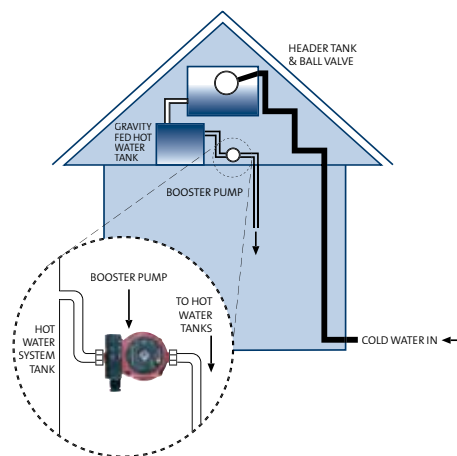

UPA needs minimum inlet pressure of 0.5 m

Selector in position		The pump ...
I	Off	is switched off
II	Auto	starts and stops automatically
III	Manual*	runs continuously (also if tapping points are turned off)

*pin must be removed for access to this setting

APPLICATIONS

Hot Water Recirculation: Grundfos Comfort system ensures that there is always hot water available when it is needed and prevents water wastage resulting from the draining of cold water.

The Grundfos Comfort system uses the cold water supply line as the “return-line” to the water heater. A Comfort pump is used to create a pressure differential that allows the cold water in the hot water supply line to by-pass (at low volume) into the cold supply line through a patented thermostatically controlled valve that is mounted under the sink furthest from the water heater.

Comfort pumps are suitable for solar hot water systems.

FEATURES

- Easy installation
- Instant hot water
- No waste of precious drinking water
- Energy effective pump with the built-in timer and thermostat (BUT model)



TECHNICAL FEATURES

Comfort system including the Comfort UP15-14 BUT pump (with lead, timer and thermostat) and valve kit		
Voltage	V	240
P1	W	25
In	A	0.11
Enclosure & Insulation class	-	IP42/F
Pump port to port dimension	mm	80
Pump connection to pipe	-	½" F
Valve Connection	-	½" M
Net weight	kg	1.16



UP15-14 BUT pump with valve kit

PERFORMANCE

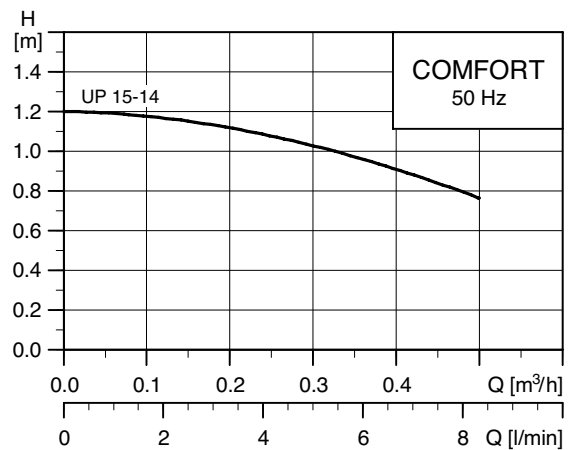

INSTALLATION

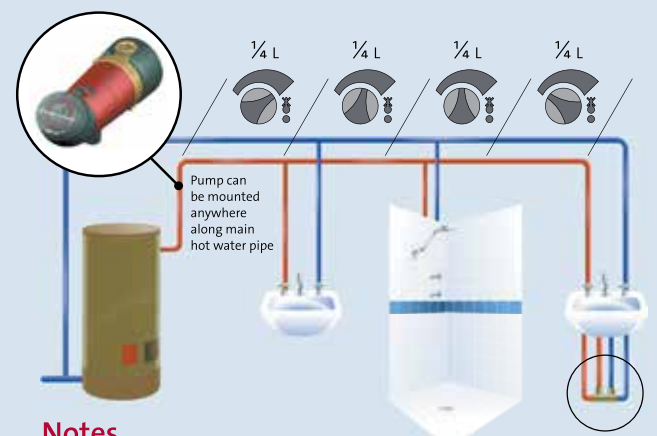

Notes

- It is normal to experience a small volume of warm water at the cold tap closest to the Comfort System Valve.
- Set timer to operate 30 minutes before hot water demand and adjust thermostat accordingly.

■ Cold Water
 ■ Hot Water
 L Length of hot water pipe

APPLICATIONS

The UPN circulator Pumps in stainless steel are specifically designed for household hot water systems, and solar hot water applications.

FEATURES

- Meets requirements of AS/NZS 4020 “Testing of products for use in contact with drinking water”. No risk to water quality thanks to the main components being stainless steel (pump housing, bearing plate, stator and rotor can (stainless steel AISI 304)
- Interchangeable with most of the installed bronze models (150 mm port to port)
- Especially designed for hot water application
UP20-60N model can also be used with chilled water from +2 °C

TECHNICAL FEATURES

Model		UP20-60N
Voltage	V	1 x 240
P1	W	90
In	A	0.37
Enclosure & Insulation class		IP44/F
Liquid temperature range	°C	+2 C to +110
Port to port dimension	mm	150
Union set (pn 52-99-82)		¾" F
Net weight	kg	2.8

INSTALLATION

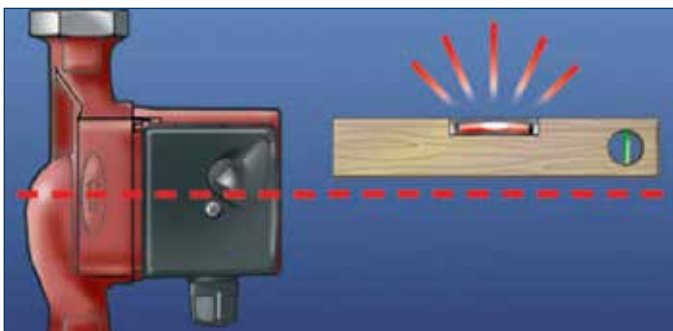

PERFORMANCE

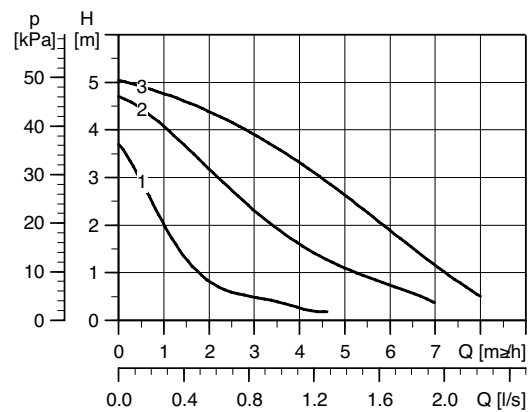

DIMENSIONS

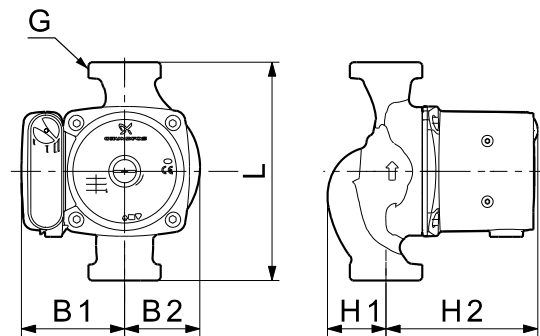

APPLICATIONS

The circulator pumps in cast iron pump housing version are specifically designed for heating systems. For underfloor heating systems, it is advisable to use the bronze version, type ALPHA 2 B and UPS B, as the pumped liquid may often become aerated, causing an ordinary cast iron pump housing to corrode.

FEATURES

- UPS can be operated at three speeds
- ALPHA 2 automatically controls the differential pressure by adjustment of pump performance to the actual heating demand, without the use of external components

TECHNICAL FEATURES

The ALPHA 2 and UPS pumps are of the canned rotor type, i.e. pump and motor form an integral unit without shaft seal and with only two gaskets for sealing. The bearings are lubricated by the pumped liquid.

Pumps		UPS25-60	ALPHA 2 25-60
Voltage	V	1 x 240	1 x 240
P1 (max speed)	W	105	90
In	A	0.44	0.40
Enclosure & Insulation class		IP44/F	IP42/F
Liquid temperature range	°C	+2 C to +110	+2 C to +110
Port to port dimension	mm	130 or 180	180
Union set		1" F	1" F
Net weight	kg	2.6	2.6

INSTALLATION



UPS and ALPHA 2

PERFORMANCE

