

Plan Your Storage Space – Don't Just Fill It!

HEALTHCARE STORAGE IS A LONG-TERM CAPITAL INVESTMENT. IT Pays to Get It Right From the Start. QC STORAGE Provides **3D WALK- THROUGH IMAGING** of Your New Storage Layout **BEFORE YOU PURCHASE!**

TABLE OF CONTENTS

INTRODUCTION

3-D WALKTHROUGH	3-4
WHY QCS?	5

WIRE SHELVING

WIRE FINISHES / BASES / SIZES	6
LABEL HOLDERS.....	7
WIRE SHELF ACCESSORIES.....	8
HIGH DENSITY TRACK / OTHER SHELF OPTIONS.....	9
FLAT SHELF BUILD OPTIONS	10
COMBINATION SHELF BASKET BUILD OPTIONS.....	11
CORNER SHELF OPTIONS	12
CATHETER STORAGE / ACCESSORIES	13

Q-WALL

Q-WALL MOBILE UNITS	14-16
Q-WALL WALL MOUNTED / CORNER.....	17

Q-TOWER

Q-TOWER STORAGE EXAMPLES	18-20
SPD STERILE CONTAINER STORAGE	21-22

LOUVERED PANELS / HOOKS / SMALL WIRE BASKETS.....	23
--	-----------

WRAP RACKS AND TRANSPORT CARTS	24
---	-----------

CATH LAB PRODUCTS / CARTS	25
--	-----------

IV POLES AND ACCESSORIES.....	26-27
--------------------------------------	--------------

SPECIALTY / TREATMENT / MEDICAL CARTS.....	28-29
---	--------------

MEDICAL SUPPLY CARTS	30
-----------------------------------	-----------

MRI CONDITIONAL CARTS	31
------------------------------------	-----------

SCOPE STORAGE CABINETS.....	32
------------------------------------	-----------

SS TABLES AND O.R. PRODUCTS	33
--	-----------

SEATING OPTIONS.....	34
-----------------------------	-----------

SPECIALTY CARTS & CUSTOM CONFIGURED CARTS.....	35
---	-----------

CART COVERS / LINEN HAMPER BAGS	36-37
--	--------------

LAYOUT EXAMPLES	38-39
------------------------------	--------------

SIMPLIFIED EQUIPMENT PLANNING ILLUSTRATIONS.....	40-41
---	--------------

OTHER STORAGE PRODUCTS AVAILABLE.....	42-43
--	--------------



Clearly and Quickly Identify YOUR Existing Products by Color Difference – In Green

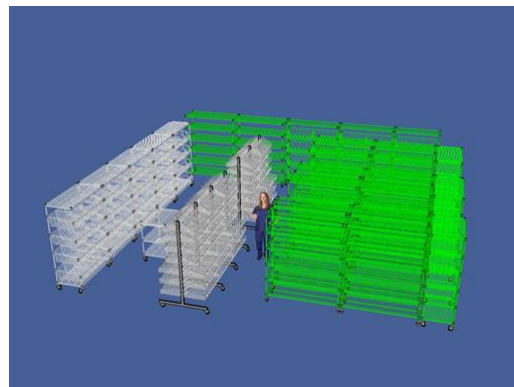

Your New Proposed Storage Area Can Be Experienced With 3D Walk Through.
INSPECT Each Aisle – Each Shelf Unit - Each Detail
Before You Purchase!

Your New Proposed Storage Area Can Be Experienced With 3D Walk-Through.
Each Aisle – Each Shelf Unit – Each Detail – **BEFORE You PURCHASE!**



Clearly and Quickly Identify **YOUR Existing Shelving** by Color Difference - In Green.

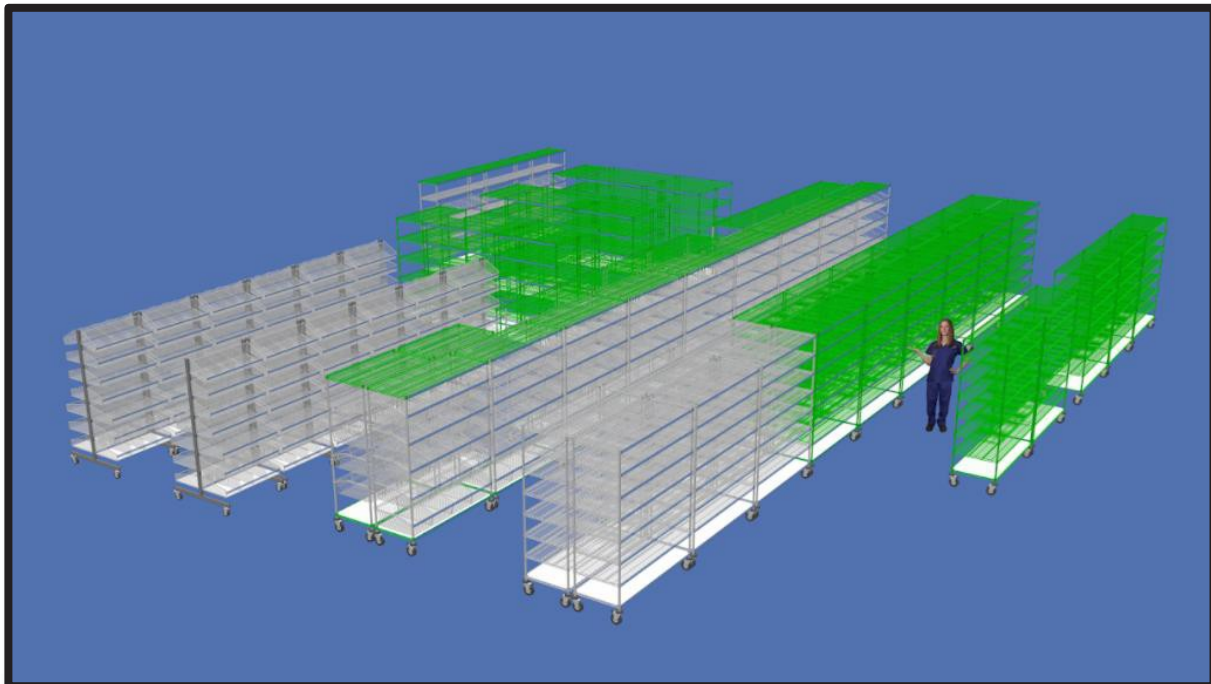



Ask Yourself One Simple Question.....

**Does Your Existing Storage
Area Work Well For You?**

**IF NOT – Why Would
You Want To REPEAT It?**

**70% of healthcare inventory items DO NOT FIT well on Flat Shelves.
Do Not Use Plastic Bins that Gather Dust, Occlude Light and Waste Space.**



We make it EASY for you and your staff throughout the process.

- NO CHARGE to Assess, Design and Quote your areas.
- We inventory your existing storage shelving for reuse.
- Our full CAD design department can work with your contractor, planner and architect.
- Detailed images of all products quoted (no guess work on what you are potentially buying!)

Wire Shelving – How To Build Your Unit

STEP #1. The Proper Finish for Your Shelf Need:

- **Chrome Finish** – Standard Silver Chrome finish is perfect for **standard storage needs** in ambient temperature areas where *humidity*, the **need for refrigeration, exposure to outdoor elements or high temp washer exposure** is not a factor.
- **DuroSeal Finish** - Is the standard for storage applications that **include exposure to outdoor elements (humidity)**, as well as areas such as **Dietary, Lab, Pharmacy and for areas that require refrigeration.**
- **Stainless Steel Finish** – is necessary when the shelving or carts are **exposed to High Temp Cart Washers**. Stainless Steel shelves can be *either* Solid or Open Wire shelves; however, both can be mixed together in a single unit.
- **Galvanized Finish** – Galvanized shelves are always “solid” shelves, however they can be mixed with open wire shelves of a different finish in a single unit.

STEP #2. The Proper Base for Your Shelf Need:

- **Stationary** – This is the standard stationary, stand alone, shelf unit base with leveling bolts at the bottom of all 4 poles.
- **Casters** – The standard configuration on casters includes **(2) 5” Locking casters** and **(2) 5” swivel casters**. Casters are appropriate for nominal movement of shelf units or cart within a facility.
- **Dolly Base** - This base is a rigid frame on casters utilized on larger carts and shelf units that are used for transport over long distances or regular and repeated transport over elevator thresholds .
- **Seismic** - Seismic anchorage may be specified. This may include OSHPD approved seismic floor mounts for all (4) posts of any shelf unit.
- **Track (High Density)**– Track with shelving on **Skates or Carriages** can be utilized where **Maximum Storage Capacity is desired**.

STEP #3 The Proper Size for Your Shelf Need:

- **How Deep (Front to Back)**

Available In The Follow Depths					
14"	18"	21"	24"	30"	36"

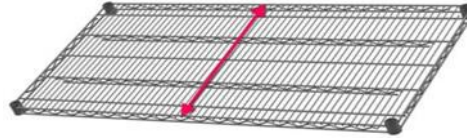

- **How WIDE (Side to Side)**

Available In The Follow Widths							
24"	30"	36"	42"	48"	54"	60"	72"

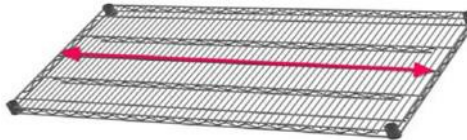

- **Baskets available in 18” & 24” Depths.**

Available In The Follow Widths			
24"	36"	48"	60"



- **Post Mount QWall available in 18” & 24” Depths.**

Available In The Follow Widths		
36"	48"	60"



Mix and Match BASKETS with Flat Shelves for a Better Fit for Your Bulky Hard to Contain Products that always wind up falling on the floor.



STEP #4. Available accessory Items:

Label Holders

3-Position Wire Shelf Label Holder

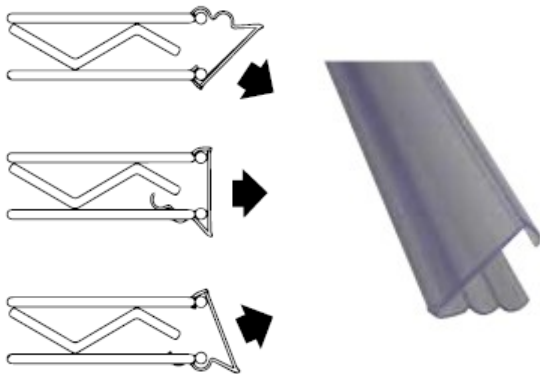

Label Holder for Wire Shelf			
TELH24CL	24"	TELH54CL	54"
TELH36CL	36"	TELH60CL	60"
TELH42CL	42"	TELH66CL	66"
TELH48CL	48"	TELH72CL	72"

Color Coded Label Holders (Snap & Release or Zip-Tie)

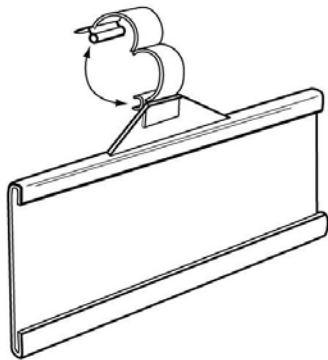
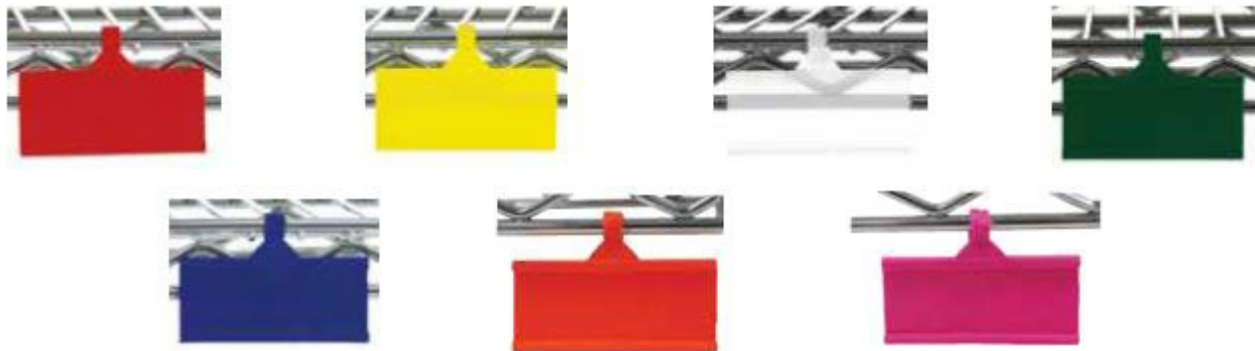

Color Coded Label Holders		
	Snap/Release	Zip-Tie
Red	TELR03RD	QQPS-LH3RD
Yellow	TELR03YL	QQPS-LH3YL
Clear	TELR03CL	QQPS-LH3CL
Green	TELR03GR	QQPS-LH3GR
Blue	TELR03BL	QQPS-LH3BL
Orange	TELR03OR	QQPS-LH3OR
Pink	TELR03PK	QQPS-LH3PK
PURPLE	N/A	QQPS-LH3PR

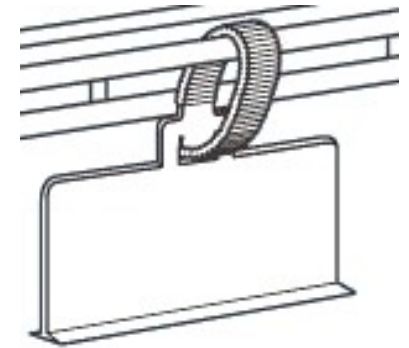

Basket Shelf & QWall Basket Label Holders



Basket Label Holder	
TELB03CL	3"
TELB18CL	18"
TELB24CL	24"
TELB36CL	36"
TELB48CL	48"
TELB60CL	60"

Paper Inserts For Label Holders Are Available Upon Request.

Shelf Liners

LAY-IN Shelf Liner

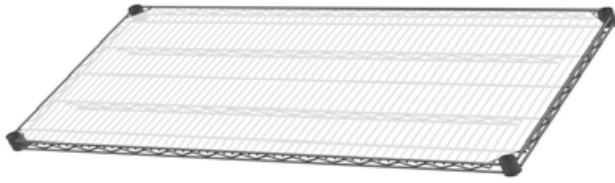

SNAP ON Shelf Liner



Dividers - Ledges - Enclosures

Flat Shelf Divider



TED148CH	14" x 8"	TEDL368CH	36" x 6"
TED188CH	18" x 8"	TEDL488CH	48" x 8"
TED218CH	21" x 8"	TEDL608CH	60" x 8"
TED248CH	24" x 8"		

Basket Dividers



TEDV1810CH	18" x 10"
TEDV1810CH-H	18" x 10" w/Front Hook
TEDV2410CH	24" x 10"
TEDV2410CH-H	24" x 10" w/Front Hook

Front/Back) Ledges



TEL144CH	14" x 4"	TEL424CH	42" x 4"
TEL184CH	18" x 4"	TEL484CH	48" x 4"
TEL244CH	24" x 4"	TEL544CH	54" x 4"
TEL304CH	30" x 4"	TEL604CH	60" x 4"
TEL364CH	36" x 4"	TEL724CH	72" x 4"

Side and Back Screens:



Side Enclosures		Back Enclosures	
TEPEC1460CH	14" x 60"	TEBRD3660CH	36" x 60"
TEPEC1860CH	18" x 60"	TEBRD4260CH	42" x 60"
TEPEC2160CH	21" x 60"	TEBRD4860CH	48" x 60"
TEPEC2460CH	24" x 60"	TEBRD5460CH	54" x 60"
TEPEC1472CH	14" x 72"	TEBRD6060CH	60" x 60"
TEPEC1872CH	18" x 72"	TEBRD7260CH	72" x 60"
TEPEC2172CH	21" x 72"	TEBRD3672CH	36" x 72"
TEPEC2472CH	24" x 72"	TEBRD4272CH	42" x 72"
		TEBRD4872CH	48" x 72"
		TEBRD5472CH	54" x 72"
		TEBRD6072CH	60" x 72"
		TEBRD7272CH	72" x 72"

OTHER SHELF OPTIONS



HIGH DENSITY TRACK SHELVING



**Maximizes Storage Capacity + Increases Productivity
= Cost-Saving Performance**

QC Storage HD System uses a skate concept, utilizing the structural integrity of the storage shelving units.

The low-profile, non-corrosive aircraft aluminum track measures 7/16" at its highest peak, allowing for easy cleaning and ADA compliance. Floor tracks provide a smooth, level surface, when inconsistent or uneven floor conditions exist.

Wire Shelving Units

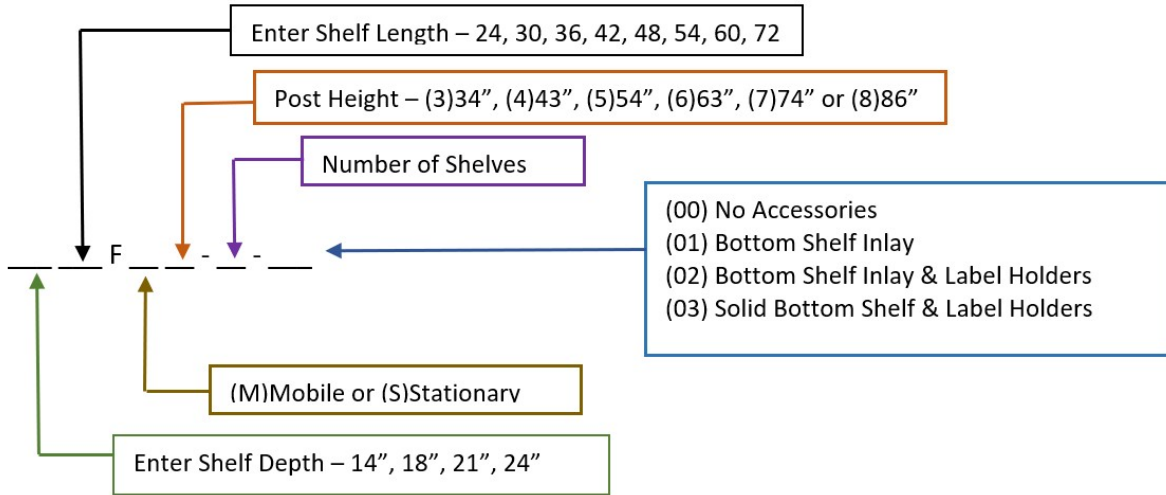

Model Number	Tiers	Post Height	Mobile	Stationary	Inlay	Label Holders	Solid Bottom Shelf
2448FS7-4-00	4	74"	-	x	-	-	-
2448FS7-5-00	5	74"	-	x	-	-	-
2448FS7-6-00	6	74"	-	x	-	-	-
2448FS7-4-01	4	74"	-	x	x	-	-
2448FS7-5-01	5	74"	-	x	x	-	-
2448FS7-6-01	6	74"	-	x	x	-	-
2448FS7-4-02	4	74"	-	x	x	x	-
2448FS7-5-02	5	74"	-	x	x	x	-
2448FS7-6-02	6	74"	-	x	x	x	-
2448FM7-4-00	4	74"	x	-	-	-	-
2448FM7-5-00	5	74"	x	-	-	-	-
2448FM7-6-00	6	74"	x	-	-	-	-
2448FM7-4-01	4	74"	x	-	x	-	-
2448FM7-5-01	5	74"	x	-	x	-	-
2448FM7-6-01	6	74"	x	-	x	-	-
2448FM7-4-02	4	74"	x	-	x	x	-
2448FM7-5-02	5	74"	x	-	x	x	-
2448FM7-6-02	6	74"	x	-	x	x	-
These Are Examples - Others Sizes Are Available Using The Format Template Above.							

Combination Shelving Units

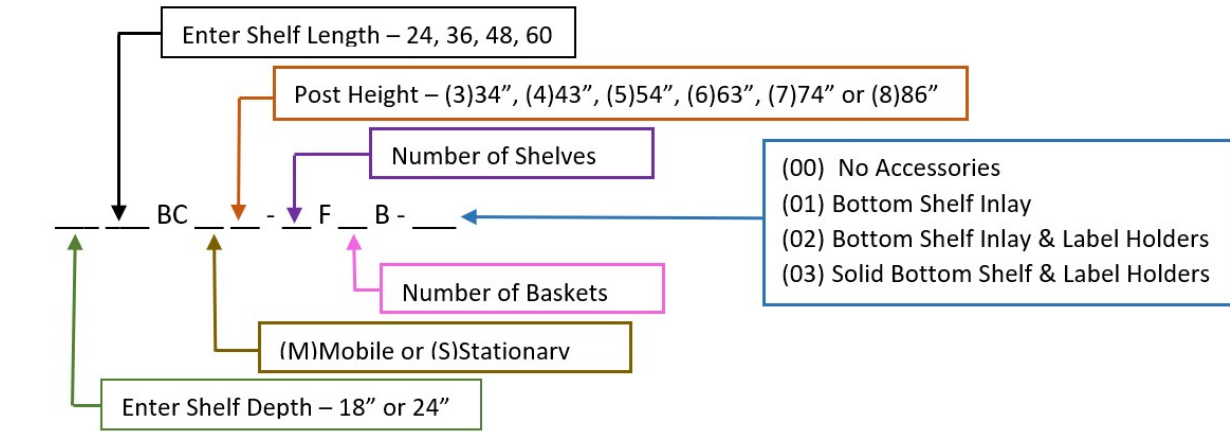

For Common Sizes See Models Numbers Below



3 Flat/ 3 Basket

4 Flat/ 3 Basket

2 Flat/ 5 Basket

Model Number	Wire Shelves	Basket Shelves	Post Height	Mobile	Stationary	Inlay	Label Holders	Solid Bottom Shelf
2448BCS7-3F3B-00	3	3	74"	-	x	-	-	-
2448BCS7-4F3B-00	4	3	74"	-	x	-	-	-
2448BCS7-2F5B-00	2	5	74"	-	x	-	-	-
2448BCS7-3F3B-01	3	3	74"	-	x	x	-	-
2448BCS7-4F3B-01	4	3	74"	-	x	x	-	-
2448BCS7-2F5B-01	2	5	74"	-	x	x	-	-
2448BCS7-3F3B-02	3	3	74"	-	x	x	x	-
2448BCS7-4F3B-02	4	3	74"	-	x	x	x	-
2448BCS7-2F5B-02	2	5	74"	-	x	x	x	-
2448BCM7-3F3B-00	3	3	74"	x	-	-	-	-
2448BCM7-4F3B-00	4	3	74"	x	-	-	-	-
2448BCM7-2F5B-00	2	5	74"	x	-	-	-	-
2448BCM7-3F3B-01	3	3	74"	x	-	x	-	-
2448BCM7-4F3B-01	4	3	74"	x	-	x	-	-
2448BCM7-2F5B-01	2	5	74"	x	-	x	-	-
2448BCM7-3F3B-02	3	3	74"	x	-	x	x	-
2448BCM7-4F3B-02	4	3	74"	x	-	x	x	-
2448BCM7-2F5B-02	2	5	74"	x	-	x	x	-

These Are Examples - Others Sizes Are Available Using The Format Template Above.

Five Sided Corner Shelving

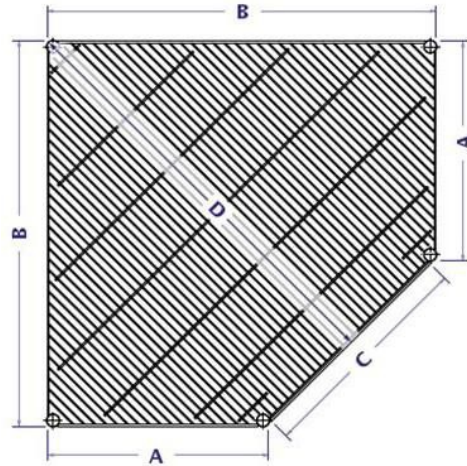

Five Sided Chrome Shelving Units Are Designed To Fit Into The Corner of Your Room and Align With Our Standard Depth Shelving. The Units Allow Access To The Recessed Area Through The Angled Front. The Shelves Are Available In (3) Depths 18", 21" and 24".

Model Number	Tiers	Post Height	Mobile	Stationary	Inlay	Label Holders	Dim "A"	Dim "B"	Dim "C"	Dim "D"
1836-5M7-5-02	5	74"	x	-	x	x	18"	36"	24"	38"
1836-5M7-6-02	6	74"	x	-	x	x	18"	36"	24"	38"
2136-5M7-5-02	5	74"	x	-	x	x	21"	36"	20"	40"
2136-5M7-6-02	6	74"	x	-	x	x	21"	36"	20"	40"
2442-5M7-5-02	5	74"	x	-	x	x	24"	42"	24"	46"
2442-5M7-6-02	6	74"	x	-	x	x	24"	42"	24"	46"
* Other Configurations Are Available Upon Request.										
** Side & Back Enclosures Are Available If Needed										

Catheter Storage Shelving

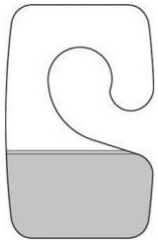
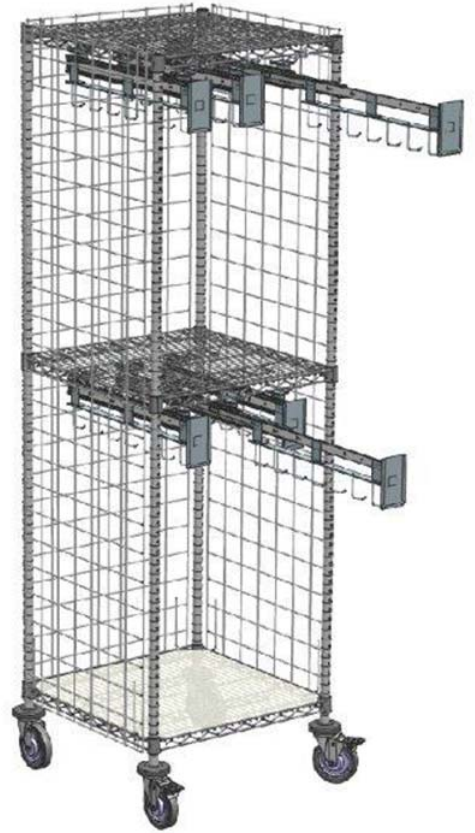

.875" x 1.375" Hook Hang Tab
SIRHT-2031-R
 Case Package: 5000

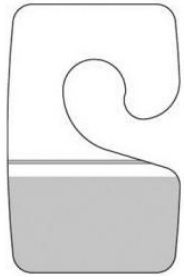

1.75" x 1.125" Hook Hang Tab
SIRHT-2011-R
 Case Package: 3500



1.625" x 1.50" Hook Hang Tab
SIRHT-7004-SH
 Case Package: 5000

Pull-Out Catheter Slide Modules For Your Existing Shelving Units. 18" Unit Has (5) Hooks & 24" Units Has (7) Hooks. 18"-MMUSC18 24" - MMUSC24

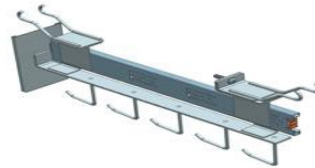

Pull-Out Catheter Slide Modules For Your Existing Cabinetry, 18" Unit Has (5) Hooks & 24" Units Has (7) Hooks. 18"-MMUSC18C 24" - MMUSC24C



Catheter Storage Bin
24" x 4" x 4" NECB24C



Q-WALL

Our Q-Wall series of shelving units will eliminate the need for dusty plastic bins for smaller items!



Q-Wall is Available in Widths of 18", 24", 36" and 48" in Both Single and Double Sided Units

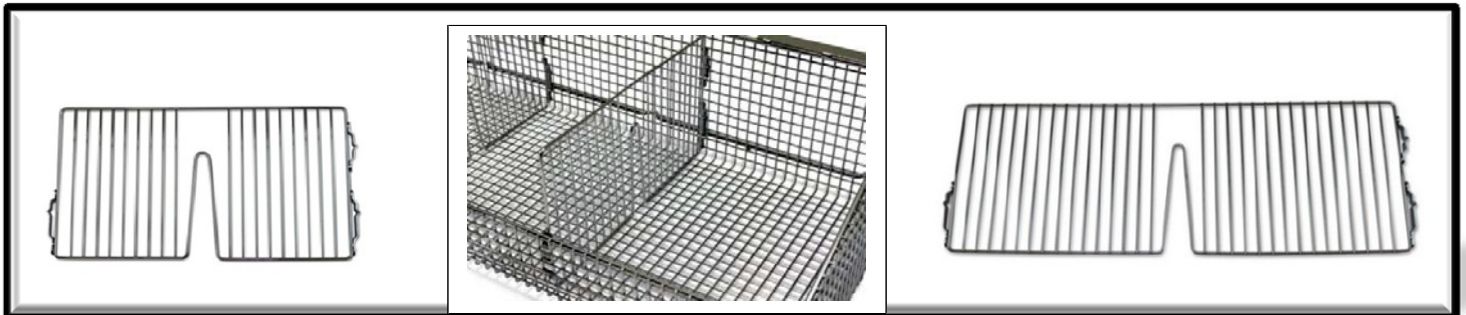

Q-Wall Efficiency Gains Space and Eliminates Dusty Plastic Bins



Wall Mounted Q-Wall Sections

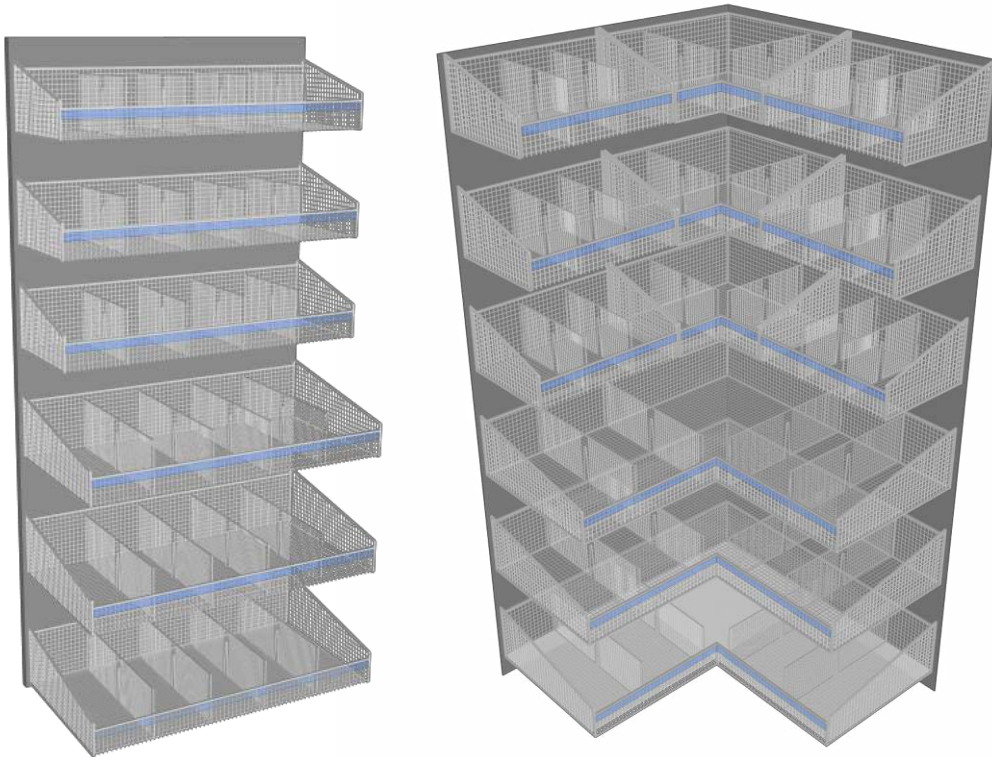

Individual Components

Model Number	Description	Width	Depth
TEH1218BSK	12" x 18" Wire Basket	18"	12"
TEH1218BSK-COR	12" x 18" Corner Wire Basket	18"	12"
TEH1224BSK	12" x 24" Wire Basket	24"	12"
TEH1236BSK	12" x 36" Wire Basket	36"	12"
TEH1248BSK	12" x 48" Wire Basket	48"	12"
TEH1818BSK	18" x 18" Wire Basket	18"	18"
TEH1824BSK	18" x 24" Wire Basket	24"	18"
TEH1836BSK	18" x 36" Wire Basket	36"	18"
TEH1836BSK-COR	18" x 36" Corner Wire Basket	36"	18"
TEH1848BSK	18" x 48" Wire Basket	48"	18"
TEH126DV	12" Divider	-	12"
TEH186DV	18" Divider	-	18"

Complete Bundles

Model Number	Description	Width	Height	12" Deep Baskets	18" Deep Baskets	Label Holders	Dividers	Basket Inlay
QWLP133	18" Q-Wall Unit 6-Tier w/Dividers	18"	61"	3	3	6	12	1
QWLP233	24" Q-Wall Unit 6-Tier w/Dividers	24"	61"	3	3	6	18	1
QWLP333	36" Q-Wall Unit 6-Tier w/Dividers	36"	61"	3	3	6	24	1
QWLP433	48" Q-Wall Unit 6-Tier w/Dividers	48"	61"	3	3	6	30	1
QWLP333-COR	36" Corner Q-Wall Unit 6-Tier w/Dividers	36"	61"	9	3	18	48	2

Mobile Q-Wall Units

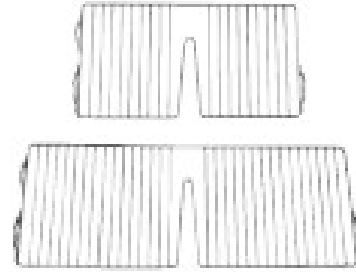
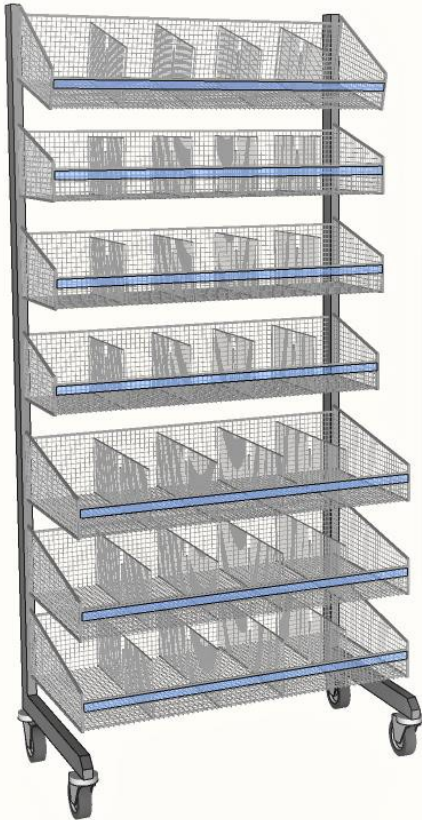

Model Number	Description	Width	Depth
TEH1218BSK	12" x 18" Wire Basket	18"	12"
TEH1224BSK	12" x 24" Wire Basket	24"	12"
TEH1236BSK	12" x 36" Wire Basket	36"	12"
TEH1248BSK	12" x 48" Wire Basket	48"	12"
TEH1818BSK	18" x 18" Wire Basket	18"	18"
TEH1824BSK	18" x 24" Wire Basket	24"	18"
TEH1836BSK	18" x 36" Wire Basket	36"	18"
TEH1848BSK	18" x 48" Wire Basket	48"	18"
TEH126DV	12" Divider	-	12"
TEH186DV	18" Divider	-	18"

Model Number	Description	Width	Height	12" Deep Baskets	18" Deep Baskets	Label Holders	Dividers	Basket Inlay
QWS143	18" Starter Q-Wall Unit 7-Tier w/Dividers	18"	78"	4	3	7	14	1
QWS243	24" Starter Q-Wall Unit 7-Tier w/Dividers	24"	78"	4	3	7	21	1
QWS343	36" Starter Q-Wall Unit 7-Tier w/Dividers	36"	78"	4	3	7	28	1
QWS434	48" Starter Q-Wall Unit 7-Tier w/Dividers	48"	78"	4	3	7	35	1
QWA143	18" Add-On Q-Wall Unit 7-Tier w/Dividers	18"	78"	4	3	7	14	1
QWA243	24" Add-On Q-Wall Unit 7-Tier w/Dividers	24"	78"	4	3	7	21	1
QWA343	36" Add-On Q-Wall Unit 7-Tier w/Dividers	36"	78"	4	3	7	28	1
QWA434	48" Add-On Q-Wall Unit 7-Tier w/Dividers	48"	78"	4	3	7	35	1
QWD143	18" Starter Double Sided Q-Wall Unit 7-Tier w/Dividers	18"	78"	8	6	14	28	2
QWD243	24" Starter Double Sided Q-Wall Unit 7-Tier w/Dividers	24"	78"	8	6	14	42	2
QWD343	36" Starter Double Sided Q-Wall Unit 7-Tier w/Dividers	36"	78"	8	6	14	56	2
QWD434	48" Starter Double Sided Q-Wall Unit 7-Tier w/Dividers	48"	78"	8	6	14	70	2
QWDA143	18" Add-On Double Sided Q-Wall Unit 7-Tier w/Dividers	18"	78"	8	6	14	28	2
QWDA243	24" Add-On Double Sided Q-Wall Unit 7-Tier w/Dividers	24"	78"	8	6	14	42	2
QWDA343	36" Add-On Double Sided Q-Wall Unit 7-Tier w/Dividers	36"	78"	8	6	14	56	2
QWDA434	48" Add-On Double Sided Q-Wall Unit 7-Tier w/Dividers	48"	78"	8	6	14	70	2

Q-TOWER

Our Q-Tower series of high density, vertical storage units will revolutionize your hospital workplace! Organize your inventory with maximum storage in a minimum space.

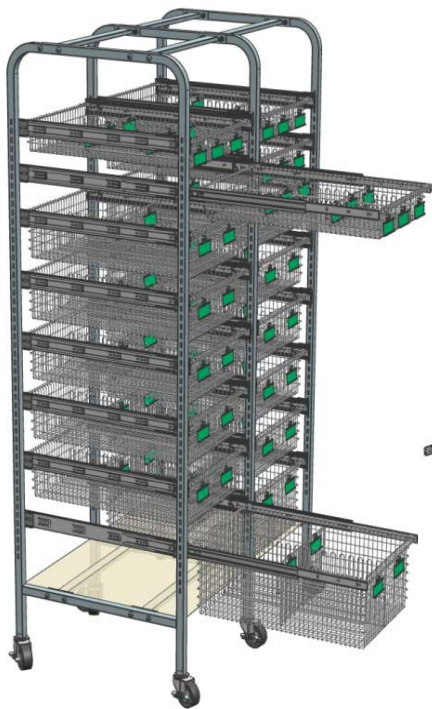

Double Unit

Single Unit

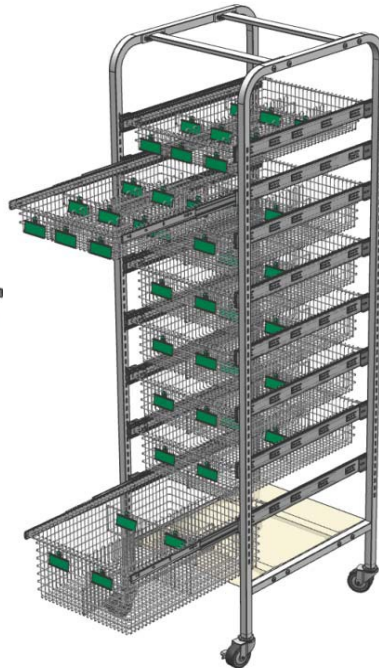

Triple Unit

Q-Tower provides mix and match capabilities of different basket depths, or flat shelf option, to perfectly fit your smaller inventory items.

Q-Tower Efficiency Gains Space and Eliminates Dusty Plastic Bins

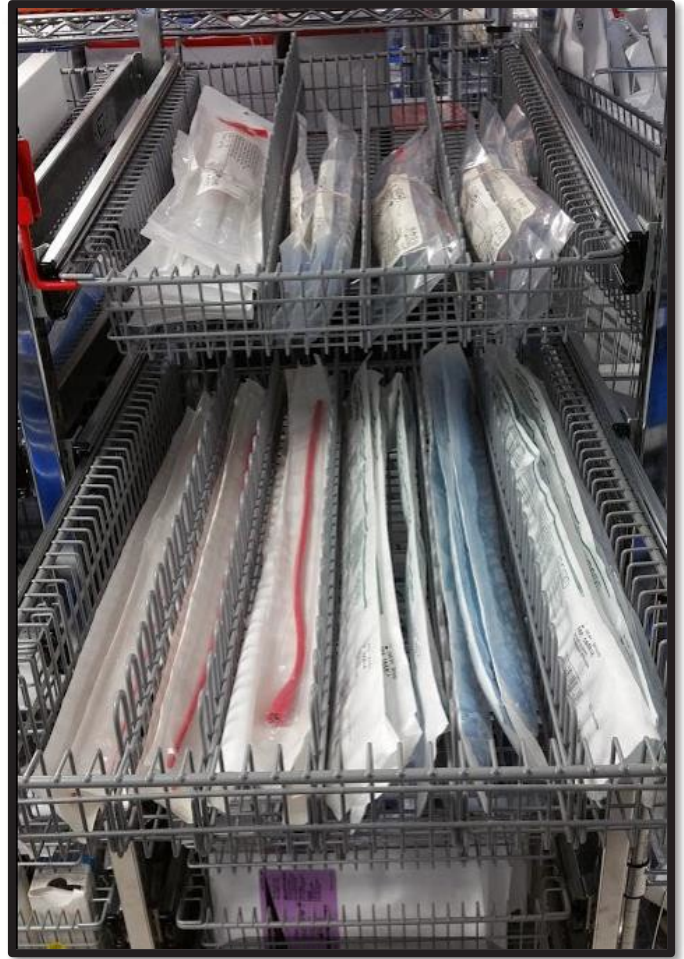

Take Control of Your Sterile Set Inventory

Meet Compliance – Reduce Employee Injury & Torn Wrappers

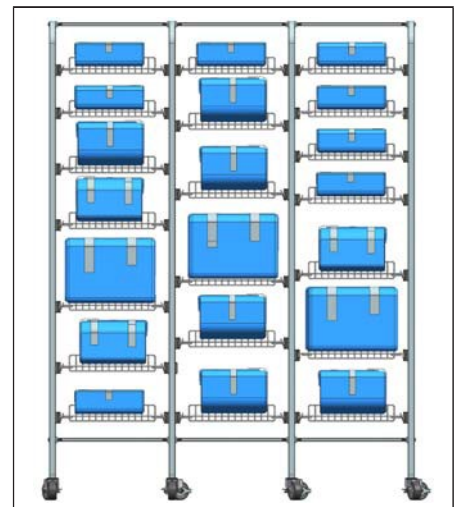
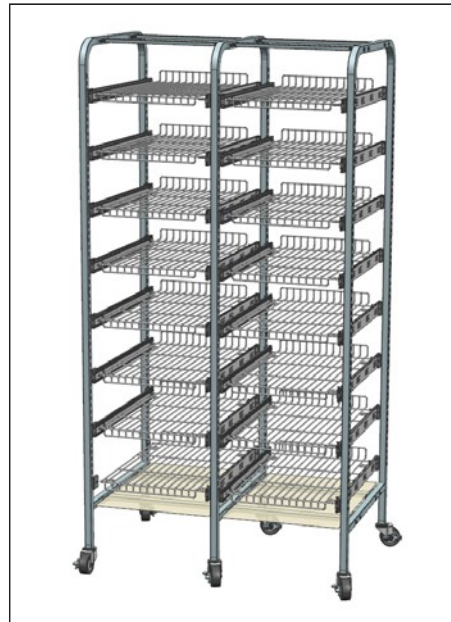
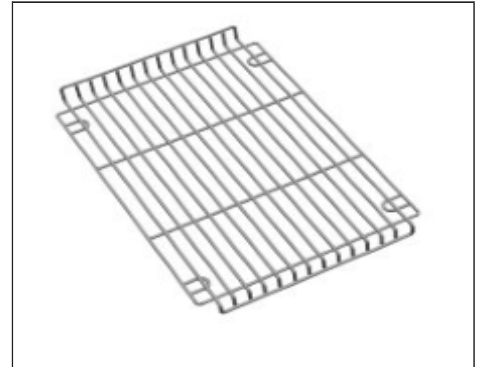

FULL DRAWER EXTENSION

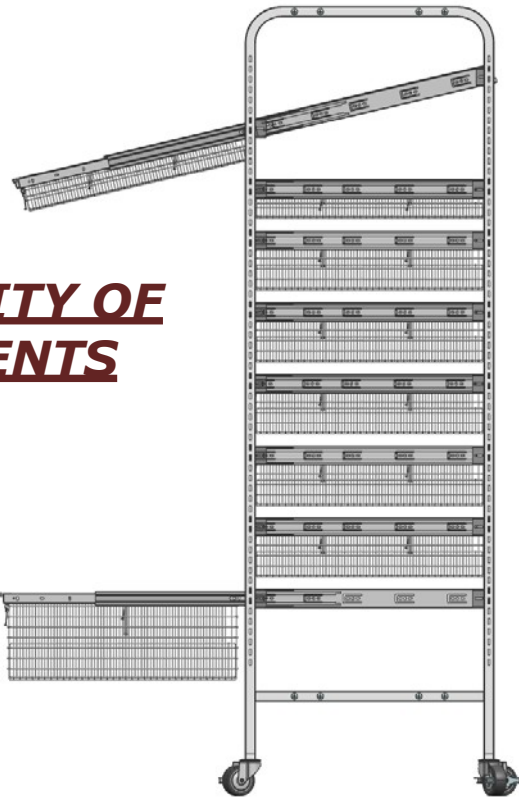
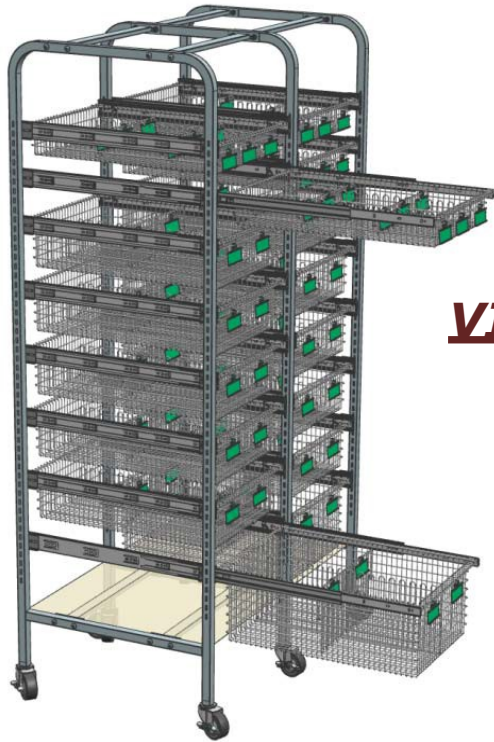

VISIBILITY OF CONTENTS



3", 5" AND 8" HEIGHTS

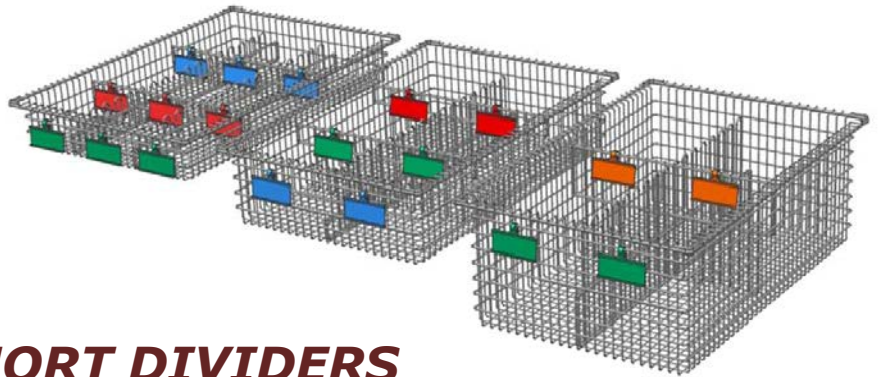

LONG AND SHORT DIVIDERS

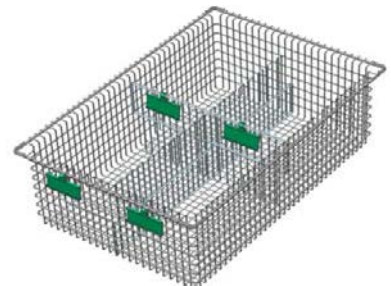
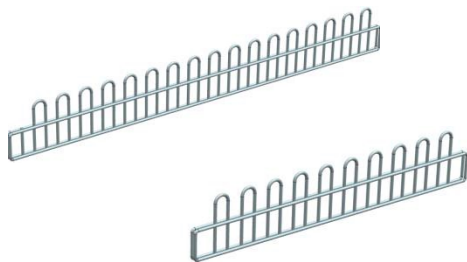
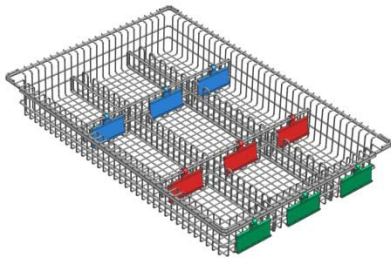

Q-Tower Storage Towers



Model #	3" Basket	5" Basket	8" Basket	Wire Shelves	Casters	Dividers	BTM Dust Cover	Description
QTRS142	1	4	2	N/A	Yes	Yes	Yes	Freestanding Starter Unit
QTRS251	2	5	1	N/A	Yes	Yes	Yes	Freestanding Starter Unit
QTRA142	1	4	2	N/A	Yes	Yes	Yes	Freestanding Adder Unit
QTRA251	2	5	1	N/A	Yes	Yes	Yes	Freestanding Adder Unit
QTRS8SH	N/A	N/A	N/A	8	Yes	No	Yes	Freestanding Starter Unit
QTRA8SH	N/A	N/A	N/A	8	Yes	No	Yes	Freestanding Adder Unit
2436PSM7-2F4P-01	N/A	N/A	N/A	6	Yes	No	Yes	24" x 36" Pull-Out Shelf Unit

Fine Mesh Basket Suture Cart



Large Supply/Suture Storage Kit Comes with:

4 – 54" posts, 2 – 24" x 48" wire shelves, 9 – 24" x 48" x 4" wire mesh baskets, 9 sets – 24" deep pullout slides, 4 – swivel caster (2 with brakes), 1 – 24" x 48" dust cover. Front to back and left to right dividers are not included but available for compartmentalization.

Model # 2448SC5-2F9B



Louvered Wall Panels

LOUVERED PANELS

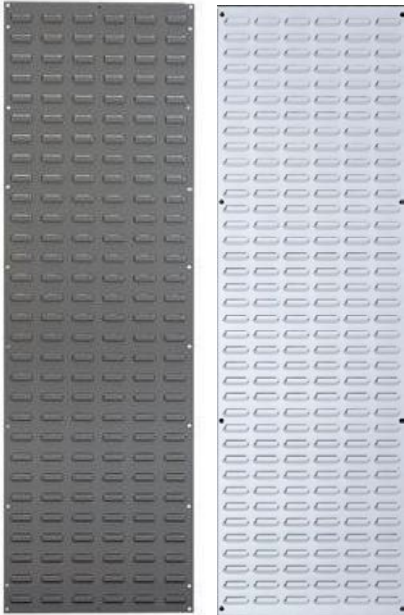

Model #	Description
QQLP-1819	18"W x 19"H Louvered Panel
QQLP-1861	18"W x 61"H Louvered Panel
QQLP-2721	27"W x 21"H Louvered Panel
QQLP-3612	36"W x 12"H Louvered Panel
QQLP-3619	36"W x 19"H Louvered Panel
QQLP-3661	36"W x 61"H Louvered Panel
QQLP-4819	48"W x 19"H Louvered Panel
QQLP-4861	48"W x 61"H Louvered Panel
QWS-SR9C	9" Single Rod Spike
QWS-HDS6	6" Heavy Duty Spike
QWS-HDS12	12" Heavy Duty Spike



Single Rod Spike



Heavy Duty Spike

Fine Mesh Hanging Wall Bins



Model #	Depth	Width	Height	Case Pack	Divider
QQMB510C	5-1/4"	4/1/4"	3"	20	QDMB510C
QQMB520C	7-1/4"	4-1/4"	3"	20	QDMB520C
QQMB530C	10-3/4"	5-1/2"	5"	10	QDMB530C
QQMB535C	10-3/4"	11"	5"	10	QDMB535C
QQMB539C	10-1/2"	8"	7"	10	QDMB539C
QQMB540C	14-1/2"	8"	7"	10	QDMB540C
QQMB550C	14-1/2"	16-1/4"	7"	5	QDMB550C
QQMB560C	18-1/2"	11"	10-1/4"	5	QDMB560C
QQMB570C	18-1/2"	17"	11-1/4"	5	QDMB570C

Wrap Racks & Utility Carts



Sterile Wrap Carts		
TEWC48CH	24" x 48" x 69"	4-Hanging Bars
TEWC60CH	24" x 60" x 69"	4-Hanging Bars



Catheter Storage Carts		
TECRS48CH	24" x 48" x 69"	8-Catheter Hooks
TECRS60CH	24" x 60" x 69"	10-Catheter Hooks



Bin Storage Carts	
TEORVTU	24" x 72" x 69" Unit with (14) Bins & (3)30" Shelves
TECVTU60	24" x 60" x 69" Unit with (7)Bins & (4)36" Wire Shelves
TECVTU72	24" x 72" x 69" Unit with (7)Bins & (4)48" Wire Shelves
TEDRAW7	24" x 24" x 69" Unit with (7) Bins
TEDRAW4	24" x 24" x 49" Unit with (4) Bins



Wire Shelf Utility Carts		
TERD282CH	18" x 30"	2-SHELF
TERD283CH	18" x 36"	2-SHELF
TERD248CH	18" x 48"	2-SHELF
TERD243CH	24" x 30"	2-SHELF
TERD244CH	24" x 36"	2-SHELF
TERD246CH	24" x 48"	2-SHELF

Wire Shelf Utility Carts		
TERD382CH	18" x 30"	3-SHELF
TERD383CH	18" x 36"	3-SHELF
TERD348CH	18" x 48"	3-SHELF
TERD343CH	24" x 30"	3-SHELF
TERD344CH	24" x 36"	3-SHELF
TERD346CH	24" x 48"	3-SHELF



Solid Shelf Utility Carts		
TERD283CH-SLD	18" x 36"	2-SHELF
TERD284CH-SLD	18" x 48"	2-SHELF
TERD244CH-SLD	24" x 36"	2-SHELF
TERD246CH-SLD	24" x 48"	2-SHELF

Solid Shelf Utility Carts		
TERD383CH-SLD	18" x 36"	3-SHELF
TERD384CH-SLD	18" x 48"	3-SHELF
TERD344CH-SLD	24" x 36"	3-SHELF
TERD346CH-SLD	24" x 48"	3-SHELF



Universal Products Supply Cart



Easy Transport of Long Cath Boxes



Fully Convertible Storage carts, with Pull-Out Wire Mesh Drawers or Plastic Bins - with Adjustable Dividers - for Smaller Items.



Durable Dolly Base for Over the Road Transportation

IV Poles and Accessories

IV Pole Buying Guide

Pole Selections

Standard



Chrome Pole:
For use in non-acute areas.

Premium



Stainless Steel Pole:
For use in OR and our most durable pole option

Caster Selections

Standard



20 Ball Bearing Casters:
Quality Caster for Lighter Weight Bases.

Premium



30 Ball Bearing Casters:
For heavy duty bases. Better elevator transitions.

Base Selections

Standard



5 Leg Economy Base:
240 diameter
For lighter use areas.



6 Leg Economy Base:
240 diameter
Better stability for use where only standard IVs administered.

Premium



5 Leg Weighted Base:
160 diameter
Available in five standard colors.
For infusion pumps when paired with SSPole.



5 Leg Spider Low Center of Gravity Base:
220 diameter
Available in five standard colors
For infusion pumps when paired with SSPole.



6 Leg Spider Low Center of Gravity Base:
220 diameter
Available in five standard colors
For infusion pumps when paired with SSPole. Most stable pole and best elevator transition.

Top Selections

Standard



2-Hook Ram's Horn Top:
For light use areas.



4-Hook Ram's Horn Top:
For standard applications.

Premium



6-Hook Ram's Horn Top:
For use in specialty applications where several different IV Bags are needed.



8-Hook Rake Top:
For use in specialty applications where several different IV Bags are needed.



MCM280 Series

Double IV Pole with Steering Wheel and Tray

MCM286

Double IV Pole with Steering Wheel and Tray

This IV Pole is designed for areas where several infusion pumps are needed such as ICU. Double poles make more spots to hang pumps and the two four hook tops make it easier to keep IV lines organized. Height adjusts from 85"-110". Our 6 Leg spider base with 3" ball bearing casters make this a very stable and easy to move pole. Full circle steering wheel makes it easy to maneuver from any side. Complete pole construction is 304 grade stainless steel. Removable plastic tray makes a great place for storage and a spot to set things during bag changes and setup.



MCM290 Series

5 Leg Foot Control IV Pole

MCM290

5 Leg Foot Control IV Pole

Fully welded stainless steel constructed IV Pole with 22" diameter 5 Leg spider base. Foot control height adjustment leaves hands free to adjust pole, IV Tubing and bags. 2" swivel casters make moving easy. Bar to protect foot pedal from getting bumped. 4 Hook ram's horn style top. 1.25" diameter pole adjust in height from 52"-94". Easy to raise, simply by lifting pole to desired height. Ships fully assembled-no further assembly required.



MCM200 Series

Lift Assist IV Poles

MCM251

4 Hook Stainless Steel Lift Assist IV Pole

MCM252

8 Hook Stainless Steel Lift Assist IV Pole

MCM253

28 Hook Stainless Steel Lift Assist IV Pole

An IV Pole designed for the nurse! Eliminates lift bags up high and straining backs and shoulders. Simply load the pole up with bags and turn the crank to raise. Adjusts in height from 56"-96" just by turning the crank. Large 6 leg base adds the needed stability. 3" scuff resistant casters provide unmatched maneuverability. Base post is 2" square stainless steel tube with upper extension tube of 1 1/4" stainless steel tube. No electric motors or hydraulic pumps to replace. Available with 4-hook, 8-hook or 28-hook top.



MCM200 Series

Infusion Pump Frame for IV Pole

MCM259

Infusion Pump Frame for IV Pole

Mounts with 2 Universal Clamps (sold separately)

This frame attaches to an IV Pole with two universal clamps (sold separately). Designed to hold up to 4 infusion pumps. 1" tubular frame in chrome construction. Measures 17 3/4" x 27 3/4".

Procedure Carts and Accessories

AVAILABLE ALUMINUM CART SIZES



Elite Aluminum Unicarts
29" Width x 24.5" Depth
(includes stabilizer base)
Drawer interior dimensions
22" Wide x 16.5" Deep

Elite Aluminum Med-Jr. Carts
23" Width x 24.5" Depth
(includes stabilizer base)
Drawer interior dimensions
16.5" Wide x 16.5" Deep

AVAILABLE STEEL CART SIZES



Steel Unicarts
29" Width x 24.5" Depth
(includes stabilizer base)
Drawer interior dimensions
22" Wide x 16.5" Deep
* includes required 4" top drawer.

Steel Med-Jr. Carts
23" Width x 24.5" Depth
(includes stabilizer base)
Drawer interior dimensions
16.5" Wide x 16.5" Deep



**6-Drawer Tall
Difficult Airway Cart
(UTGKA-333369-LTB)**
With Optional
Accessories



**X-Tall Malignant
Hyperthermia Cart
(UXGKA-36F-DKB)**



**5-Drawer Tall
Cast Cart
(UTGKA-33669-GRA)**



**5-Drawer Junior Medium
Suture Cart
(JMGKA-333369-LTG)**
With Optional
Accessories



**5-Drawer Tall
Phlebotomy Cart
(MTWA-34696-WHT)**



**4-Drawer Short
Phlebotomy Cart
(MSWA-3469-WHT)**



**4-Drawer Junior Short
IV Cart
(JSGKA-3369-WHT)**
With Optional
Accessories



Feature Comparison

ELITE ALUMINUM	VS.	TRADITIONAL STEEL
Unicart Construction <input checked="" type="checkbox"/>		Unicart Construction <input type="checkbox"/>
Auto-closing Ball Bearings Sides <input checked="" type="checkbox"/>		Auto-closing Ball Bearings Sides <input type="checkbox"/>
Easy-roll Casters <input checked="" type="checkbox"/>		Easy-roll Casters <input type="checkbox"/>
Includes Drawer Divider Set <input checked="" type="checkbox"/>		Includes Drawer Divider Set <input type="checkbox"/>
Universal Accessory Mounting System <input checked="" type="checkbox"/>		Universal Accessory Mounting System <input type="checkbox"/>
Dual Pullout Work Shelves <input checked="" type="checkbox"/>		Dual Pullout Work Shelves <input type="checkbox"/>
Lightweight Construction <input checked="" type="checkbox"/>		Lightweight Construction <input type="checkbox"/>

ANESTHESIA CARTS



EMERGENCY CARTS



Feature Comparison

ELITE ALUMINUM vs. TRADITIONAL STEEL

Unicart Construction	●	●	Unicart Construction
Auto-closing Ball Bearings Slides	●	●	Auto-closing Ball Bearings Slides
Easy-roll Casters	●	●	Easy-roll Casters
Includes Drawer Divider Set	●	○	Includes Drawer Divider Set
Universal Accessory Mounting System	●	○	Universal Accessory Mounting System
Dual Pullout Work Shelves	●	○	Dual Pullout Work Shelves
Lightweight Construction	●	○	Lightweight Construction

Feature Comparison

ELITE ALUMINUM vs. TRADITIONAL STEEL

Unicart Construction	●	●	Unicart Construction
Auto-closing Ball Bearings Slides	●	●	Auto-closing Ball Bearings Slides
Easy-roll Casters	●	●	Easy-roll Casters
Includes Drawer Divider Set	●	○	Includes Drawer Divider Set
Universal Accessory Mounting System	●	○	Universal Accessory Mounting System
Dual Pullout Work Shelves	●	○	Dual Pullout Work Shelves
Lightweight Construction	●	○	Lightweight Construction



Break-Away Lock



Key Lock



Individual Drawer Gate-Locks With Key Override



Push Button Lock W/Key Override



Key-Pad Lock W/Key Override



Proximity Key-Pad Lock W/Key Override



Medical Storage Carts and Accessories



Medical Storage Carts Are Available In Single, Double or Triple Column Width with Tambour or Hinged Doors. The Interiors are Available with Shelves, Trays, Cath Slides or Any Combination To Meet Your Needs. Cart Bases Can Be Customized to Accommodate a Robotic Delivery Cart.



MRI Conditional Procedure Carts



- Designed for compatibility in MRI suites
- Tested by independent testing authority to 3 Tesla level (copies of report available)
- Meets American Society for Testing and Materials (ASTM) International, designation: F2503-05 definition of “MR-Conditional”
- Cabinet painted gloss white with MRI identification sticker applied
- Low-ferrous, ball-bearing, full extension drawer slides
- Low-ferrous 5” sealed ball-bearing casters; full swivel – one with brake, one directional
- BEST® brand lock on cabinet, with 2 keys
- Painted aluminum break-away lock bar with 100 break-away seals
- Corner bumpers, protecting the cart
- Painted aluminum pull-out shelf
- Antimicrobial plastic top, removable
- MR-Conditional accessories available
- Latex free
- Durable, hard-baked powder coat finish

Scope Cabinets



The Sure-Dry Scope Cabinet includes the industry best Positive Pressure HEPA Filtered Drying system. Inside air is replaced inside the cabinet 4 times per minute. Meets or exceeds Joint Commission, AORN, SGNA, and AAMI guidelines. Available In Painted Steel or Stainless Steel.

Stainless Steel O.R. Equipment

Stainless Steel Tables



MCM500 Series Instrument Tables with Shelf

Our most common instrument table with lower shelf. Also known as a back table in the OR. Fully welded stainless steel construction. These tables are manufactured to our CR specifications and do not have any open cavities to collect unwanted substances. All edges are glove friendly. Ships fully assembled.

- › Easy to clean
- › Noripped gloves
- › Transport & moves smoothly

MCM501	160W x 200L x 340H
MCM519	200W x 200L x 340H
MCM502	160W x 300L x 340H
MCM503	180W x 330L x 340H
MCM504	200W x 360L x 340H
MCM505	240W x 360L x 340H
MCM506	200W x 480L x 340H
MCM507	240W x 480L x 340H
MCM508	240W x 600L x 340H
MCM509	240W x 720L x 340H



MCM510 Series Instrument Tables with H-brace

Instrument table with H-brace adds more clearance around the base of the tables for storage and fitting around obstacles. Fully welded stainless steel construction. These tables are manufactured to our CR specifications and do not have any open cavities to collect unwanted substances. All edges are glove friendly. Ships fully assembled.

- › Easy to clean
- › Noripped gloves
- › Transport & moves smoothly

MCM510	160W x 200L x 340H
MCM511	160W x 300L x 340H
MCM512	180W x 330L x 340H
MCM513	200W x 360L x 340H
MCM514	240W x 360L x 340H
MCM515	200W x 480L x 340H
MCM516	240W x 480L x 340H
MCM517	240W x 600L x 340H
MCM518	240W x 720L x 340H



MCM560 Series Nested Instrument Tables

Instrument tables that nest together for storage. U-brace also allows for maneuverability around obstacles. Fully welded stainless steel construction. These tables are manufactured to our CR specifications and do not have any open cavities to collect unwanted substances. All edges are glove friendly. Ships fully assembled.

- › Less storage space required
- › Noripped gloves
- › Transport & moves smoothly

MCM560	Set of 6 Nested Tables
MCM561	140W x 280L x 320H
MCM562	160W x 320L x 340H
MCM563	180W x 360L x 360H
MCM564	200W x 400L x 380H
MCM565	220W x 440L x 400H
MCM566	240W x 480L x 420H

Stainless Steel Utility Tables



Utility Table with 3-sided guardrail and lower drawers. Standard size is 16"W x 20"L and 34"H. Also available in a larger size, custom sizes and configurations available on request. 2 locking caster on front to secure unit in place. Locking top drawer available. Fully welded construction and manufactured to our medical specifications suitable for use in the OR.

- Heavy Duty 16 gauge #304 stainless steel construction.
- Drawers mounted on ball bearing glides.
- 3-sided guardrail.

MCM 520... One drawer with shelf

MCM 521... Two-drawer with shelf

MCM 522... Three drawer with shelf

MCM 523... Four drawers with shelf

Additional Stainless Steel Items



Surgical Seating



328 Foot Operated Stool

- Controls: manual hydraulic foot pump
- Base: dark gray metal
- Backrest: none



331 Foot Operated Stool

- Controls: manual hydraulic foot pump
- Base: dark gray metal
- Backrest: ergonomic back w/twin arms



322 Hand Operated Stool

- Controls: pneumatic hand lever
- Base: chrome
- Backrest: none



323 Hand Operated Stool

- Controls: pneumatic hand lever
- Base: chrome
- Backrest: ergonomic



327 Foot Operated Stool

- Controls: pneumatic foot ring
- Base: chrome
- Backrest: curved body support



329 Foot Operated Stool

- Controls: manual hydraulic foot pump
- Base: dark gray metal
- Backrest: ergonomic



	Treston Ergo 30 AL	Treston Ergo 30 AL ESD	Treston Ergo 35 AL	Treston Ergo 35 AL ESD
Description	With soft dual-wheel safety castors with load-sensitive brakes.	With conductive soft dual-wheel safety castors with load-sensitive brakes.	High version with foot ring and glides.	High ESD version with foot ring and conductive glides.
Code	C30AL	C30AL-ESD	C35AL	C35AL-ESD

Specialty Items

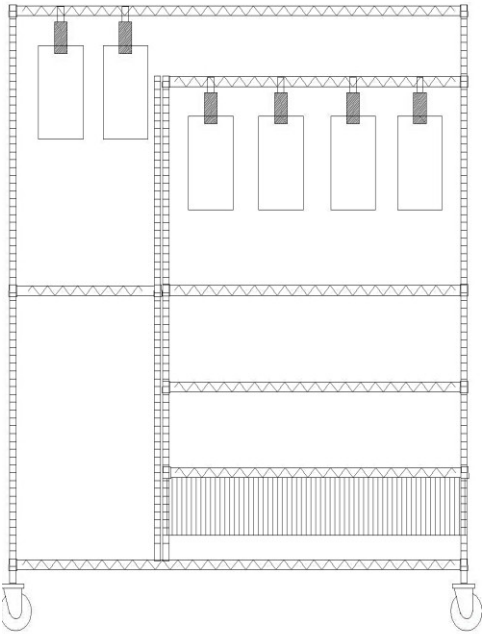
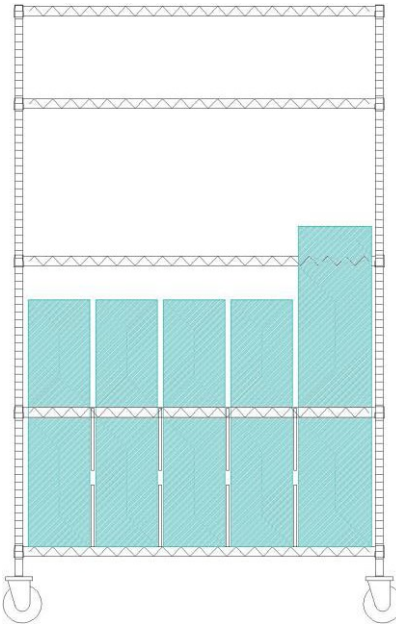
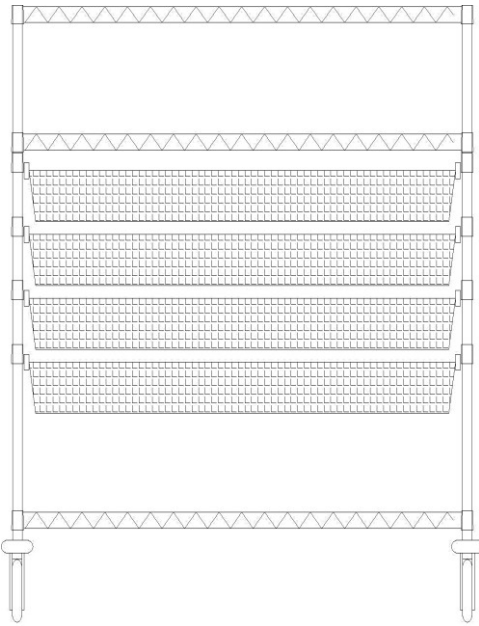

Linen/Vinyl Cart Covers



Complete Line of Custom Size Cart Covers Available

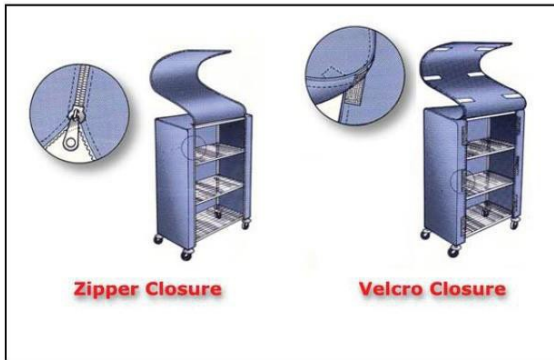

DISPOSABLE CART COVERS



Cart Cover Specification Form

Hospital/Company Name: _____ Attn: _____

Phone: _____ Fax: _____ Email: _____

Quantity: _____ Cart Brand Name: _____

Cart Style: Square Corner _____ Rounded Corner _____ Utility Cart w/Handles _____

Measurements: Depth _____ Front to Back

Width _____ Left to Right

Height _____ Exclude Casters

If ordering a utility cart cover, please provide location of the handles. (Attach Photo if Possible)

Cover Options:

Materials: _____ 400 Denier Nylon _____ Pro-Check Antimicrobial _____ Clear Vinyl

Front Flap: _____ Solid Nylon _____ Clear Vinyl _____ Clear Vinyl Strips _____ No Flap _____ Flaps on Both Sides
_____ Clear View Window in Nylon Flap (please provide size and location)

Flap Closure Type: _____ Zipper _____ Velcro

Card Holder: _____ (9" x 12") Location of Holder:

Tie Straps: _____ Top Corners _____ Bottom Corners

Cover Colors:

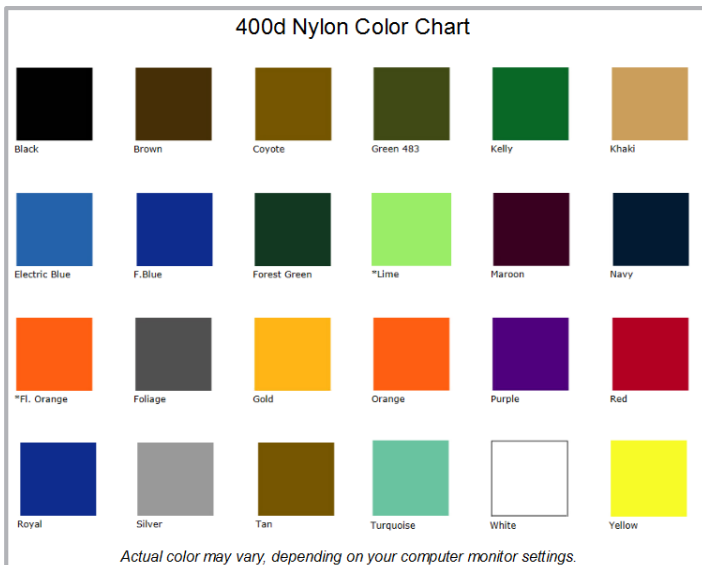

SPD - OPTION 1
2,369 PROPOSED LINEAL FT STORAGE

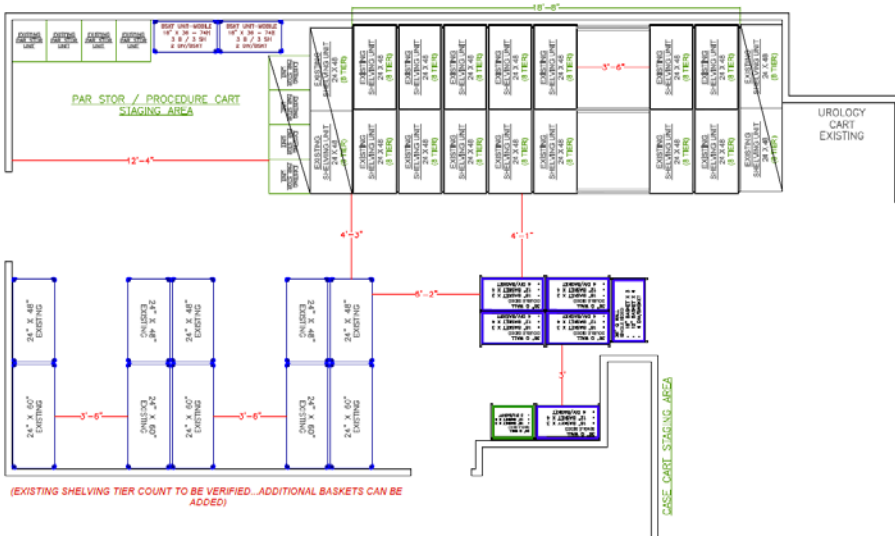

Same Room:

- 3 Different Layouts
- Same Product Mix
- 3 Different Storage Amounts Achieved

SPD - OPTION 2
2,269 PROPOSED LINEAL FT STORAGE

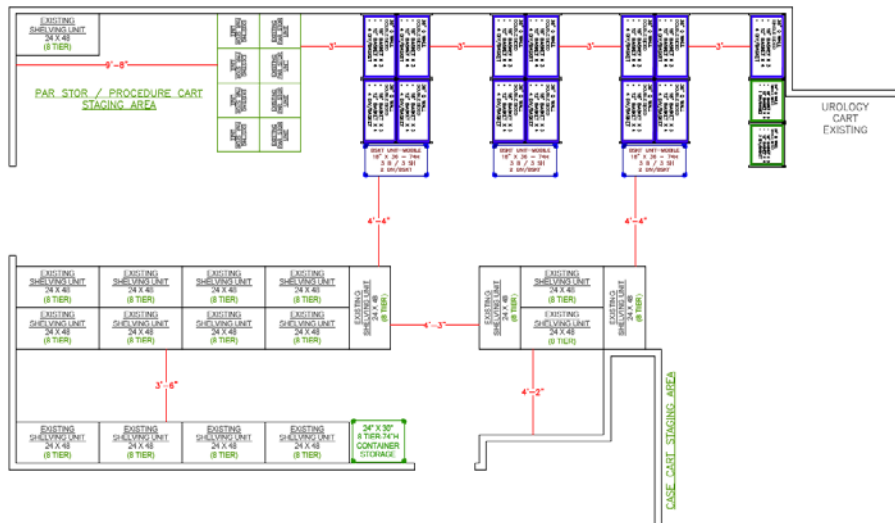

SPD - OPTION 3
2,249 PROPOSED LINEAL FT STORAGE

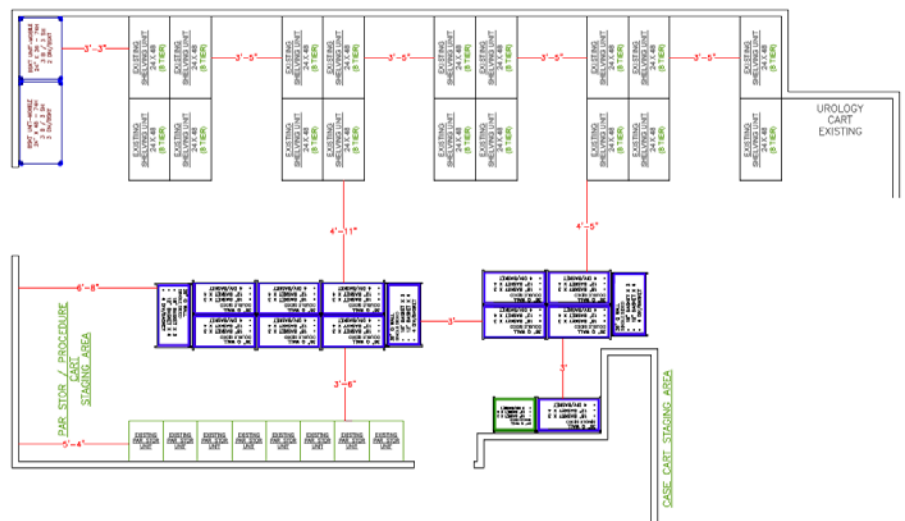

Maximize Your Storage Efficiencies
by allowing QC STORAGE to provide you creative options of your storage space:

- Use your existing shelving
- Gain storage space
- Eliminate dusty plastic bins
- Increase overall efficiencies
- Reduce expired products
- Increase flow and logistics

Option # 1 = 3,144 SQ FT Storage

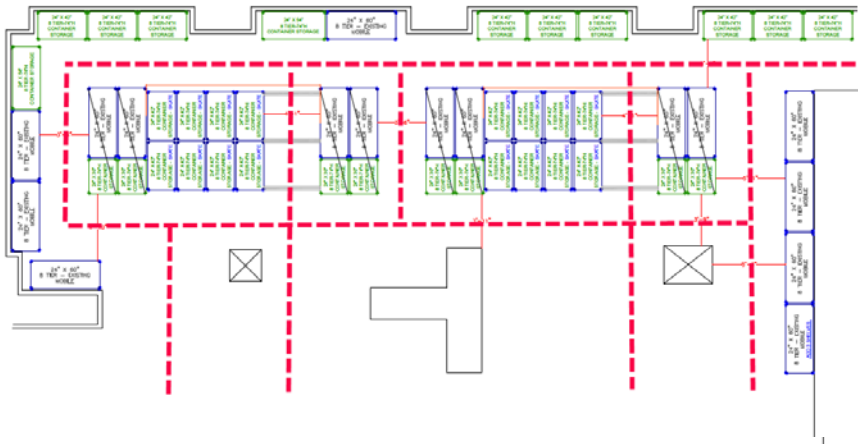

**Consider your Pathways
and Product Flow -
Before You Purchase**

Option # 2 = 3,016 SQ FT Storage

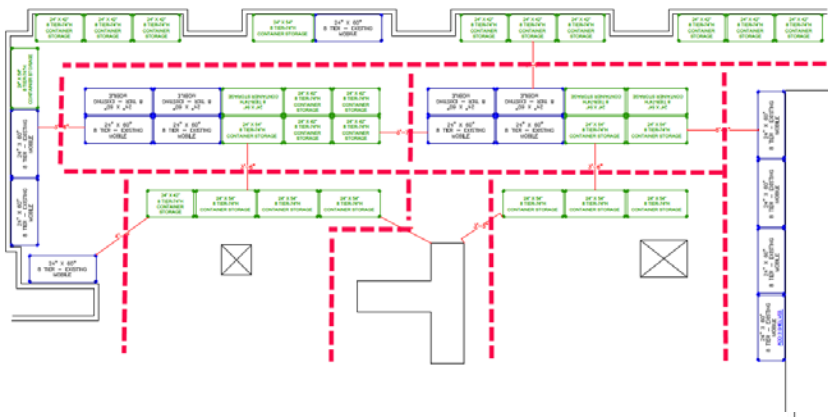

Investigate Your Options

Same Room:

- 3 Different Layouts
- Same Product Mix
- 3 Different Storage Amounts Achieved

Option # 3 = 2,912 SQ FT Storage

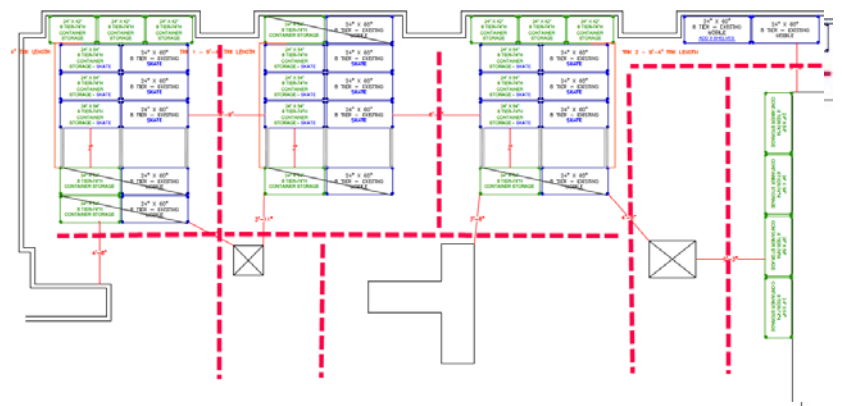

Standard Equipment List

1	AltID#	Qty	Description	Manufacturer	Model	Department	Room Name	Room #	N/E
113	E.0714	1	Waste Can, Swing Top	Rubbermaid	3071-20	3rd Floor 28 Bed Patient Unit 1	3rd Floor 28 Bed	'C365	N
114	E.0246	1	Dispenser, Hand Sanitizer, Wall Mount	Unspecified		3rd Floor ICU	3rd Floor Family	'C313	N
115	E.0327	1	Ice Machine, Dispenser, Nugget, Countertop	Follett Corporation	25CI400	3rd Floor ICU	3rd Floor Family	'C313	N
116	E.0706	1	Waste Can, 32-36 Gallon	Rubbermaid	Brute	3rd Floor ICU	3rd Floor Family	'C313	N
117	E.0211A	1	Dispenser, Beverage, Coffee	Douwe Egberts Coffee	C-300	3rd Floor ICU	3rd Floor Family	'C313	L
118	E.0446	1	Oven, Microwave, Countertop	Sears Commercial	Kenmor	3rd Floor ICU	3rd Floor Family	'C313	N
119	E.0617	1	Stool, Step	Pedigo Products	P-10	3rd Floor ICU	3rd Floor Family	'C313	N
120	E.0246	1	Dispenser, Hand Sanitizer, Wall Mount	Unspecified		3rd Floor 28 Bed Patient Unit 1	3rd Floor Family	'C385	N
121	E.0327	1	Ice Machine, Dispenser, Nugget, Countertop	Follett Corporation	25CI400	3rd Floor 28 Bed Patient Unit 1	3rd Floor Family	'C385	N
122	E.0706	1	Waste Can, 32-36 Gallon	Rubbermaid	Brute	3rd Floor 28 Bed Patient Unit 1	3rd Floor Family	'C385	N
123	E.0211	1	Coffee Maker, Single cup	Douwe Egberts Coffee	C-60	3rd Floor 28 Bed Patient Unit 1	3rd Floor Family	'C385	L
124	E.0446	1	Oven, Microwave, Countertop	Sears Commercial	Kenmor	3rd Floor 28 Bed Patient Unit 1	3rd Floor Family	'C385	N
125	E.0617	1	Stool, Step	Pedigo Products	P-10	3rd Floor 28 Bed Patient Unit 1	3rd Floor Family	'C385	N
126	E.0246	1	Dispenser, Hand Sanitizer, Wall Mount	Unspecified		3rd Floor ICU	3rd Floor ICU	'C344	N
127	E.0708	1	Waste Can, 44-55 Gallon	Rubbermaid	2655/26	3rd Floor ICU	3rd Floor ICU	'C344	N
128	E.0069	2	Bucket, Mopping	Royce Rolls Ringer	483 (8	3rd Floor ICU	3rd Floor ICU	'C344	N
129	E.0245A	1	Dispenser, Glove, Triple Box	Health Care Logistics	7467-01	3rd Floor ICU	3rd Floor ICU	'C344	E
130	E.0243	1	Dispenser, Cleaning Solution	JohnsonDiversey	Butcher	3rd Floor ICU	3rd Floor ICU	'C344	E
131	E.0136	2	Cart, Housekeeping, Stainless	Royce Rolls Ringer	F36-	3rd Floor ICU	3rd Floor ICU	'C344	N
132	E.0714	1	Waste Can, Swing Top	Rubbermaid	3071-20	3rd Floor ICU	3rd Floor ICU,	'B301	N
133	E.0246	1	Dispenser, Hand Sanitizer, Wall Mount	Unspecified		3rd Floor ICU	3rd Floor ICU,	'C307	N
134	E.0706	1	Waste Can, 32-36 Gallon	Rubbermaid	Brute	3rd Floor ICU	3rd Floor ICU,	'C307	N
135	E.0246	1	Dispenser, Hand Sanitizer, Wall Mount	Unspecified		3rd Floor ICU	3rd Floor ICU,	'C310	N
136	E.0056B	1	Board, White, Dry Erase	Quartet GBC Office	2544	3rd Floor ICU	3rd Floor ICU,	'C310	N
137	E.0327	1	Ice Machine, Dispenser, Nugget, Countertop	Follett Corporation	25CI400	3rd Floor ICU	3rd Floor ICU,	'C310	N
138	E.0706	1	Waste Can, 32-36 Gallon	Rubbermaid	Brute	3rd Floor ICU	3rd Floor ICU,	'C310	N
139	E.0211	1	Coffee Maker, Single cup	Douwe Egberts Coffee	C-60	3rd Floor ICU	3rd Floor ICU,	'C310	L
140	E.0520	1	Refrigerator, Domestic with Freezer	Sears Commercial	Kenmor	3rd Floor ICU	3rd Floor ICU,	'C310	N
141	E.0446	1	Oven, Microwave, Countertop	Sears Commercial	Kenmor	3rd Floor ICU	3rd Floor ICU,	'C310	N
142	E.0712	1	Waste Can, Open Top	Rubbermaid	2956	3rd Floor ICU	3rd Floor ICU,	'C352	N
143	E.0712	4	Waste Can, Open Top	Rubbermaid	2956	3rd Floor ICU	3rd Floor ICU,	'C353	N

QC Storage Equipment List with Product Images for Clarification

1	Item ID	Description	Qty	MANUFACTURER	PART NUMBER	DEPARTMENT	ROOM NO.	BUDGET EACH	BUDGET TOTAL
2	2013	CART, CASE LARGE	12	METRO	CASE L-36	 O.R.	2251		
3	2020	CART, CATHETER, 6 SHELVES, TOP & BOTTOM	1	METRO	CC-5M	 UROLOGY	2621		
4	11545	SHELVING SYSTEMS, WAREHOUSE	20	EAGLE	07UL9630-4H-D	 BULK STORES	1020		
5	11585	ALLOWANCE, BINS, STORAGE	7	TORAGE SYSTEMS UNLIMITED	VARIOUS	 SPD	2001		
6	2030	CART, ISOLATION, 3 DRAWER, METAL	3	ARMSTRONG MEDICAL	ABL-Y-3	 O.R	2237		
7	11163	CART, NURSE SERVER	8	METRO	SXSMDSRG	 ICU	2021		
8	12309	CART, PHLEBOTOMY	2	MARKETLAB	GO CART	 ICU	2021		
9	12097	CART, RESUSCITATION PEDIATRIC	2	WATERLOO HEALTHCARE	UTGLU-3PEDS	 PED E.D.	1041		
10	2025	CART, RESUSCITATION, MULTI DRAWER	11	ARMSTRONG MEDICAL	AP6, AOB1, ACB-1 APT-2, PMP-1, ASU-1	 EMERGENCY	1030		
11	2037	CART, SPECIALTYPROCEDURE	7	METRO	SXRSMDSRG	 PRE OP	2012		
12	2038	T, STERILE WRAP, CHROME WIRE, BOTTOM SH	1	METRO	SWF56EDC / 246DCI-4	 SPD	2001		

Steps To Completing Storage Projects On Time And Under Budget

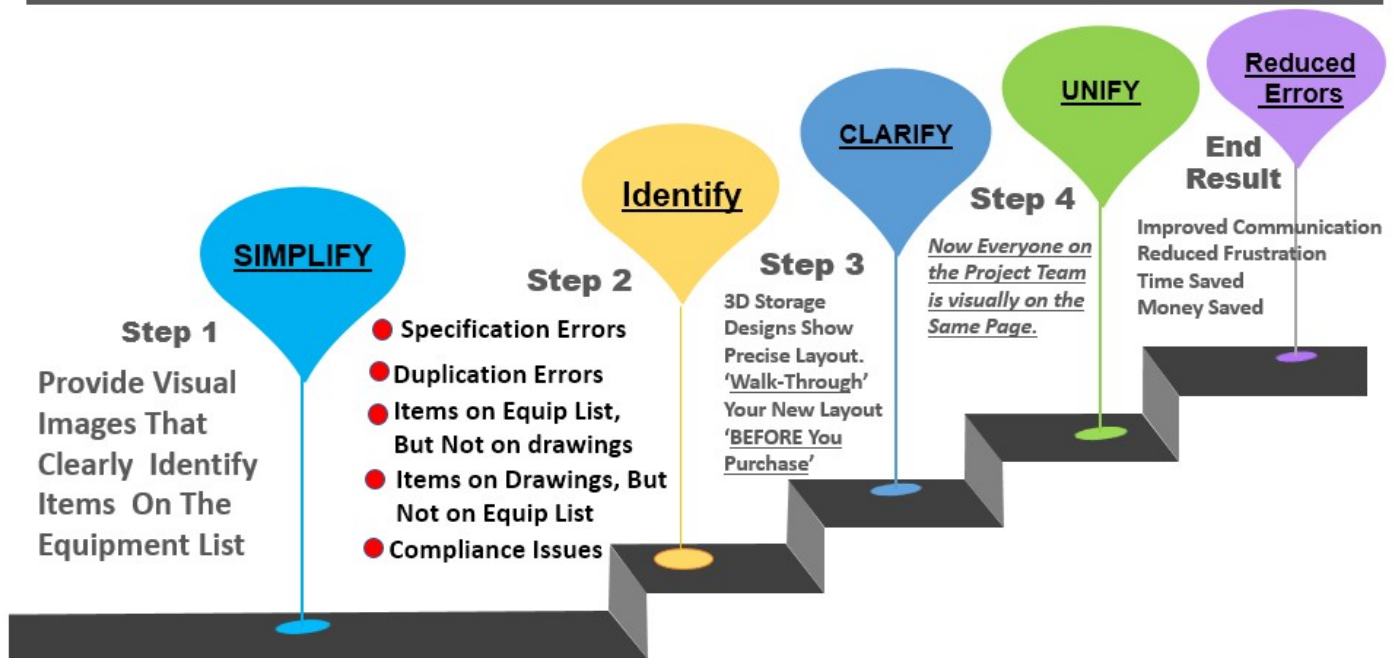



Narcotic Cabinets

MEDICAL / BP BASKETS



15" WALL MOUNT STORAGE BASKET



19" WALL MOUNT STORAGE BASKET



IV STAND MOUNT BLOOD PRESSURE BASKET



WALL MOUNT BP BASKET



#181501

#181651

#181650

#181601

#181502

#181680

#181681

#181683



Laptop/Vital Signs Stand



Bag & Glove Protection System





QC Storage LLC, 518 W. Nezpique Street, Jennings, LA 70546-5200, 1-855-824-5572,
info@qcstorage.net, www.qcstorage.net