

OCTOBER 1961

NO. 1192

Servicing the

Kodak Retina Reflex III Camera



EASTMAN KODAK COMPANY

Apparatus Service Department

ROCHESTER 4, N. Y.

SERVICE INSTRUCTIONS
RETINA REFLEX III CAMERA

1. F I L M T R A N S P O R T

SPECIFICATIONS

1. The rewind post assembly should:
 - a) Be retained by detent action when flush with top housing.
 - b) Not require excessive force to withdraw it from detent position.
 - c) Rotate in both directions with a minimum of resistance when flush with top.
2. Film type indicator inner ring should rotate with sufficient resistance to prevent accidental movement during normal use.
3. Film advance lever should:
 - a) Close aperture cover, lower mirror assembly, open shutter blades, set shutter, and open diaphragm blades of lens assembly to full aperture.
 - b) Rotate sprocket and take-up spool. (Clutch assembly should have sufficient torque to take up film).
 - c) Advance film counter one mark at end of stroke. (Accuracy - $\pm 1/3$ of a division).
 - d) Be locked when the exposure dial indicates the final or No.1 exposure.
4. Film take-up spool should not be cracked or broken and must have both take-up lugs.
5. Exposure release button should:
 - a) Be free of binds and have spring tension sufficient to return button to up position.
 - b) Be threaded to accept a cable release.
 - c) Be locked by safety catch insert until catch is depressed.
 - d) When depressed:
 1. Trip shutter, aperture cover, and mirror.
 2. Release film transport mechanism at the same time or slightly in advance of tripping shutter.
 3. Have a slight amount of overtravel after tripping shutter.
6. Safety catch insert should:
 - a) Lock exposure release button until depressed.
 - b) Be free of binds and have sufficient spring tension to return to the lock position after depressing.
7. Counter advance button should:
 - a) Be free of binds and have sufficient spring tension to return to right end of its travel.
 - b) When actuated:
 1. Rotate the exposure counter dial a maximum of two divisions.
 2. Release a partially advanced film advance lever.
 3. Release the film advance lever when locked by exposure counter dial in the No.1 position.
8. Rewind clutch button should:
 - a) When depressed, release film transport for rewinding of film.
 - b) Remain in depressed position until released on first actuation of film advance lever.

9. Pressure pad, back frame, film roller, and film rails should be free of imperfections which can damage film detrimentally in the picture area.
10. Back should be free of dents and imperfections sufficient to cause difficult film advance.
11. Camera should wind and rewind film smoothly.

DISASSEMBLY WITH REASSEMBLY NOTES

When the film advance lever and body release are actuated, the sequence of action of the basic film wind and shutter setting mechanisms is practically the same as in the Retina Reflex S Model, except that:

- a) Exposure release (with lock button) is on front of camera.
- b) There is no separate film wind release button.
- c) Exposure counter and actuating mechanisms are on the bottom of camera.

12. Clamping Transmission Cord

Certain repairs (such as replacement of winding mechanism components, adjustments of the wind release, or adjustment of the shutter release in relation to the mirror release) will require clamping the transmission cord. To prevent loss of the cord over the lower roller set (and subsequent removal of the entire front to replace the cord) the following method is recommended.

Disassembly

- a) Remove top housing, meter assembly (Instruction 26.1) and pentaprism assembly.
- b) Loosen (by approximately $1\frac{1}{2}$ turns) the screw retaining the vertically stacked rollers at the front of the meter drive drum.
- c) Place lower cord under lower roller and upper cord between the two rollers. Tighten screw sufficiently to hold cord, using care to prevent cutting cord, then remove cord from drum.

Reassembly

- a) Refer to Instruction 27, for installation of cord and Instruction 26.2 meter alignment.
- b) Assemble balance of camera.

13. Adjustment - Wind Release or Shutter Release

Disassembly

- a) Disassemble and clamp cord as suggested in Instruction 12.
- b) Remove cover discs as shown:

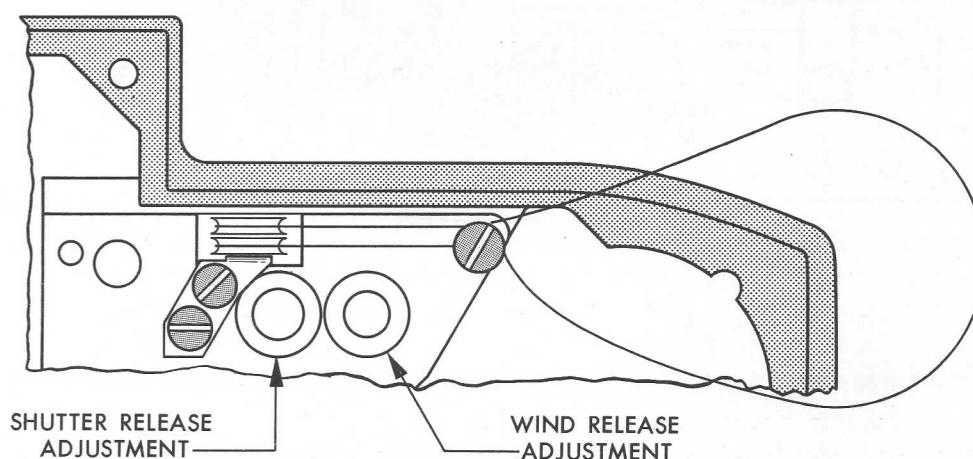

- c) If shutter release adjustment is required it is necessary to peel back cover on front and also remove cover disc on front to allow visible contact with adjustment screw.
- d) Wind release adjustment; rotate screw counterclockwise to trip wind release in advance of shutter release.
- e) Shutter release adjustment; remove cement on screw visible thru front, then rotate counterclockwise to delay shutter tripping in relation to mirror release. Re-seal screw after adjustment.

Reassembly

- a) Replace cord (Instruction 12.2).
- b) Replace meter and align (Instruction 26.2).

14. Adjustment - Exposure Counter

- a) Loosen screw in center of counter assembly.
- b) Rotate cutout disc in either direction to place index mark in alignment with pointer.

15. Winding Shaft Assembly

Disassembly

- a) Disassemble and clamp cord (Instruction 12.1).
- b) Remove advance lever and bottom panel.
- c) Remove counter advance slide and film advance lock.
- d) Set exposure counter at # 1.
- e) Remove setting rack and shaft assembly in the usual manner.

Reassembly

- a) Insert shaft assembly so that lug "A" is in the position shown. Replace screws and tighten securely.

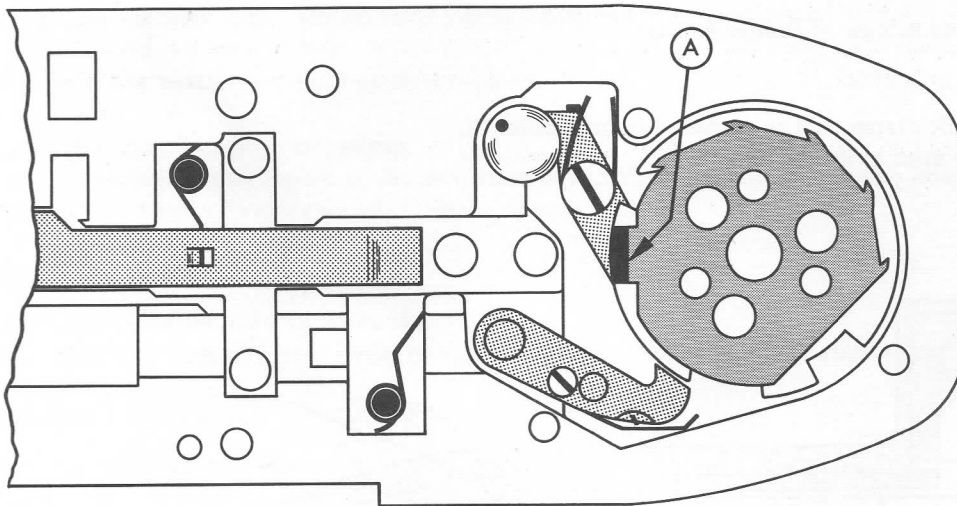

- b) Replace bushing and gear assembly and balance of components with exception of setting rack.

- c) Pretension wind shaft by rotating lug "A" clockwise $1 \frac{1}{3}$ turns to the position shown. Then insert the "Film Advance Lock Assembly".

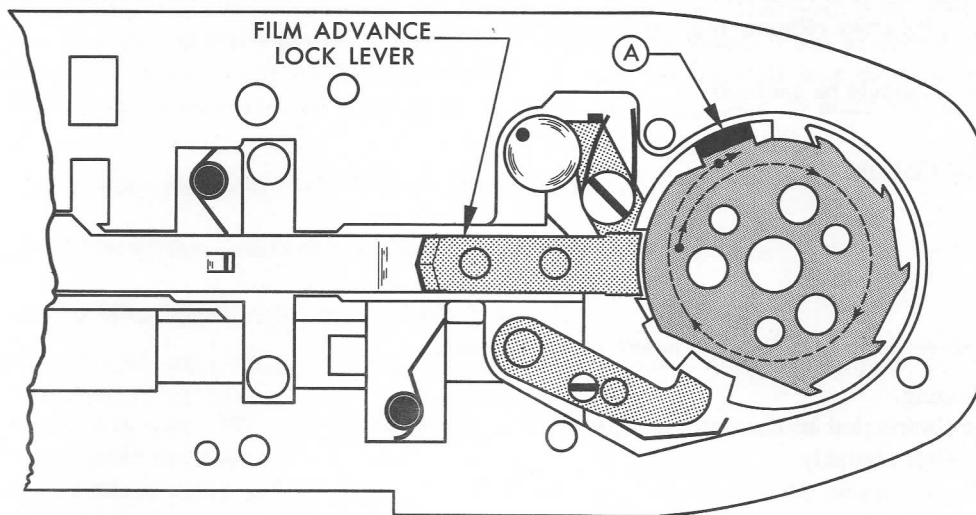

- d) Replace counter advance slide, rehook slide actuating spring, film advance lock lever spring, aperture cover slide lock spring, bottom panel and advance lever.
e) Reposition transfer shaft and replace setting rack, hold down bracket and cord drum.
f) Replace cord (Instruction 12.2) and meter (Instruction 26.2) and reassemble balance of camera.

II. R A N G E F I N D E R S P E C I F I C A T I O N S

16. Taking lens focus and rangefinder alignment should be checked on an object or chart 15-feet from film plane approximately the rear top edge of top housing.
17. Maximum permissible focus scale error of rangefinder should be limited to width of extended portion of knurled ring at focusing index arrow (50mm, f/2.8 and f/1.9).
18. Rangefinder circles should be concentric.

DISASSEMBLY WITH REASSEMBLY NOTES

19. Pentaprism

Disassembly

CAUTION: Never remove pentaprism before meter assembly.

- a) Remove top housing.
- b) Remove meter (Instruction 26.1).
- c) Remove pentaprism assembly.

Reassembly

- a) Replace pentaprism.
- b) Replace and align meter (Instruction 26.2).
- c) Replace top housing.

20. Adjustment - Rangefinder

Rangefinder adjustments using the standard 50mm lens are made in the same manner (i.e., on mirror bracket assembly) as on the Reflex S model. If the adjustment is made at Inf. position, the subject distance must be at least 165 yards from the film plane.

III. EXPOSURE METER LINKAGE

SPECIFICATIONS

21. ASA scale lock button should:

- a) When depressed permit changing film speed indication as desired (with setting wheel) from 3 to 3200.

NOTE: Resistance may be encountered in setting the film speed. Continue to turn the setting wheel if possible; this changes the shutter speed setting automatically. However, if the shutter speed and lens opening scales have both reached the limit of their travel, it will be necessary to release the lock button, rotate the setting wheel until the lens opening scale is at its opposite extreme; then again press down the lock button and rotate the setting wheel to reach the desired film speed.

- b) Have spring tension sufficient to return button to up position.

22. ASA scale of meter should hold its position at any setting within its range.

23. Meter setting wheel should (with lens assembly removed):

- a) Rotate diaphragm ring from f/1.9 through f/22 and back to f/1.9 at any speed from "B" to "500" without binds or locking.
- b) When speed ring is at "500" and diaphragm ring is set to f/1.9 and extra force is applied, rotate speed ring from "500" to "B" and stop.
- c) When speed ring is at "B" and diaphragm is at f/22 and extra force is applied, rotate speed ring from "B" to "500" and stop.
- d) Movie meter needle as follows: (initial settings - ASA10, "B", f/1.9 and all light excluded from cell) rotation of diaphragm ring (with wheel) toward f/2.8 should immediately move needle from alignment with top of rear yellow pointer (top window) into alignment with top of front yellow pointer. Further rotation of diaphragm ring to f/8 should then move meter needle toward rear of window until it comes to an abrupt stop at approximately midpoint of the rear pointer. Completion of the rotation to f/22 should cause no further movement of the needle.

NOTE: When extra force is applied to setting wheel at this position, it will rotate speed ring from "B" to "500", but no further movement of the needle should occur.

- e) Rotation of the setting wheel in opposite direction from "500" and f/22 position (with cell covered) should cause no action of needle until after 1/8 second position is reached. Continued rotation should then move the needle back to its original position of alignment with tip of rear yellow pointer.

24. Meter setting wheel should (with either lens in position) actuate the depth of field pointer of the lens.

25. Centering the meter needles within the limiting index pointers in both the finder and top housing window should indicate a diaphragm opening according to the following table when camera is set to ASA10 and exposed to a brightness of 520 foot-lamberts (Exposure Meter Tester, Tool #991, set at 100 volts). Normally, a test at 1/30 second will be sufficient.

1/4 second	-	between f/22 and f/16	1/60 second	-	between f/5.6 and f/4
1/15 "	-	between f/16 and f/8	1/125 "	-	between f/4 and f/2.8
1/30 "	-	between f/8 and f/5.6			

DISASSEMBLY WITH REASSEMBLY NOTES

26. Meter

Disassembly

- a) Remove lens assembly and set camera to "B", f/1.9 and "ASA10".
- b) Remove top housing and meter retaining screws.

CAUTION: Never remove pentaprism assembly in advance of meter removal.

- c) Remove meter by carefully (to avoid bending lower needle) lifting dial end slightly and sliding toward hinge end.
- CAUTION: Do not operate film advance lever unless a short screw is fitted in rack hold down bracket.

Reassembly

a) Set camera to "B" and "f/1.9" and remove transmission cord from locking lug of meter drive drum.

NOTE: In some cases it will not be necessary to remove the cord from locking lug of drum if the same meter is fitted. It is also important that the locking lugs (see Instruction 27) be centered between the two sets of rollers at the front of camera.

b) Set meter at "ASA10" (hold top gear and rotate bottom gear), then position ASA dial as shown:

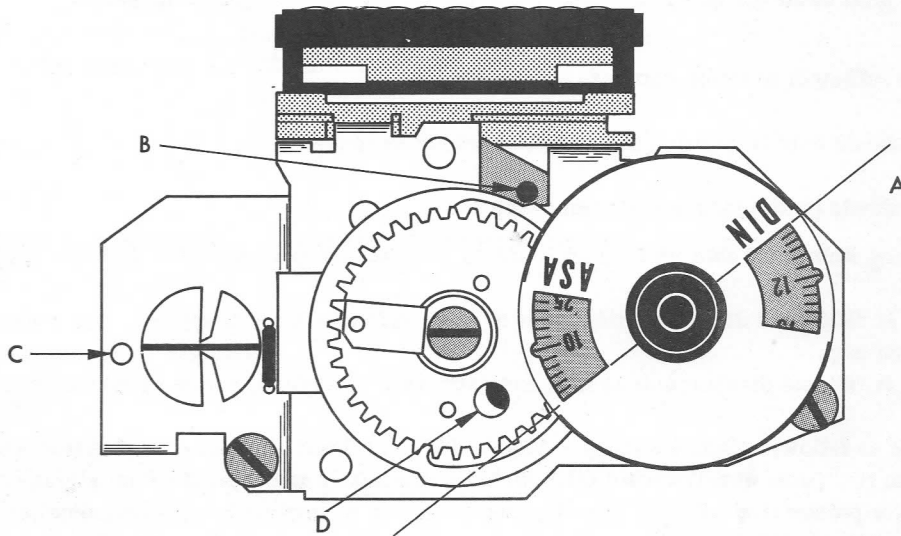

Note the following:

- A. An imaginary line "A" as shown should be tangent to the outside diameter of the gear teeth.
- B. Stud "B" should be off the high point of cam. This allows the short circuit switch to close and short out meter cell.
- C. When cell is shorted out the meter needle "C" should be at "zero position" and be visible in the small opening.
- D. Alignment hole "D" in gear should show a half moon shape below gear.

c) Grasp meter by ASA dial and carefully insert the lower needle and mask into pentaprism assembly and engage the bottom gear of meter with gear of meter drive drum.

d) Insert meter retaining screws and check out meter linkage as follows:

1. With settings "B", "f/1.9" and "ASA10" the meter needle should be visible in the small opening (zero position). Slight discrepancies can be adjusted by inserting a suitable tool into the small slot of the black moveable meter housing (rotate meter housing with setting wheel to expose the slot at rear of meter and moving the small lever).
2. Slowly move the diaphragm ring (with setting wheel) toward "f/2.8". Meter needle should jump from "zero position" toward front of meter before the diaphragm ring reaches the position shown, ("8" of "f/2.8" in alignment with the 1 second index).

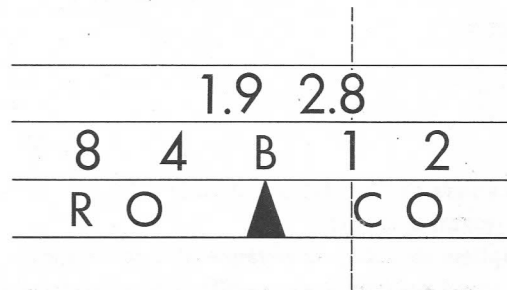

e) Temporarily fit the meter bezel and top housing and check the meter control in the following manner:

1. Position camera in front of standard light source (see Instruction 25).
 2. Set shutter at 1/30 second and align meter needle (with setting wheel) between the two yellow pointers on top housing. At this setting the diaphragm ring must indicate a reading between f/5.6 and f/8.
- f) If adjustment is required, remove top housing and with a suitable tool, block the rotation of the meter drive drum (to slip cord on drum) while rotating the diaphragm ring with the setting wheel into the tolerance (f/5.6 and f/8).
- g) Recheck for zero position (d - 1).
- h) When meter reads correctly, rotate meter drive drum (with setting wheel) until the two slots (of locking lug) are at the rear. Then carefully insert the upper turn of cord (Type A installation) into the slots.
- i) Recheck all settings and the position of the lower meter needle, with top housing fitted, by observing its location under the controlled light source. When the top needle is between the yellow pointers, the lower needle must indicate the same position. Adjustment of the lower needle can be accomplished by slight re-forming with tweezers.

27. Transmission Cord

NOTE: Two types of cord installations have been used on the Reflex III Camera. These are identified as shown in the following sketches. It is recommended that if the front assembly of the camera is removed for any reason, all Type A installations should be replaced with the Type B.

Type A Cord Installation

The following sketch illustrates the complete cord installation with camera set at "B", "f/1.9" and "ASA10". Note that the alignment of the cord from the drive drum and over roller sets #1 and #2 is identical with the "S" models of the Retina Cameras. The installation over the #3 rollers and around the meter drive drum is somewhat different from the previous models. Some meter drive drums carry two sets of anchoring slots but only the straight slots are used for this purpose on this type.

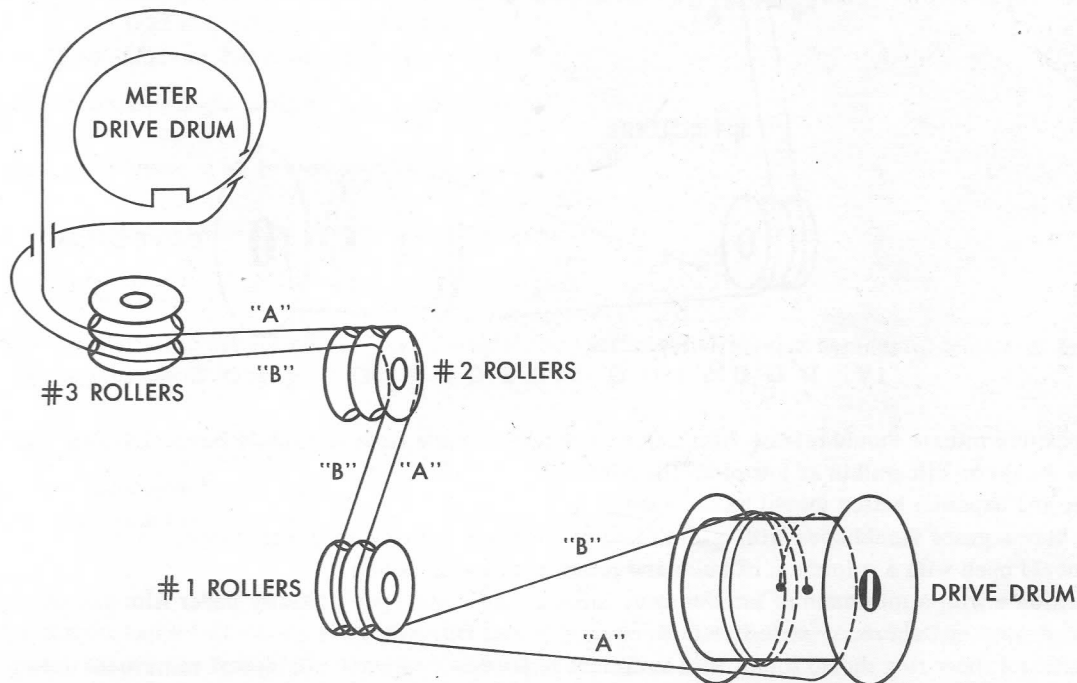

NOTE:

Disassembly of front from camera will not require bottom panel removal if the following method is used:

- a) Peel back bottom covering at front edge and remove three panel to case screws.
- b) Carefully force bottom panel away from case and insert a thin piece of metal at each side of front mount and remove front in usual manner.

Type B Cord Installation (preferred)

The following sketch illustrates the complete cord installation with the camera set at "B", "f/1.9" and "ASA10". Note that the cord from the drive drum over roller sets #1 and #2 is identical with the "S" models of the Retina Cameras. The installation over the #3 rollers and around the meter drive drum is somewhat different from the previous models. Some meter drive drums carry two sets of anchoring slots but only the angle slots are used for this purpose on this type. When readjustment or replacement of the linkage is completed it is suggested that the cord be cemented in position at the locking lug.

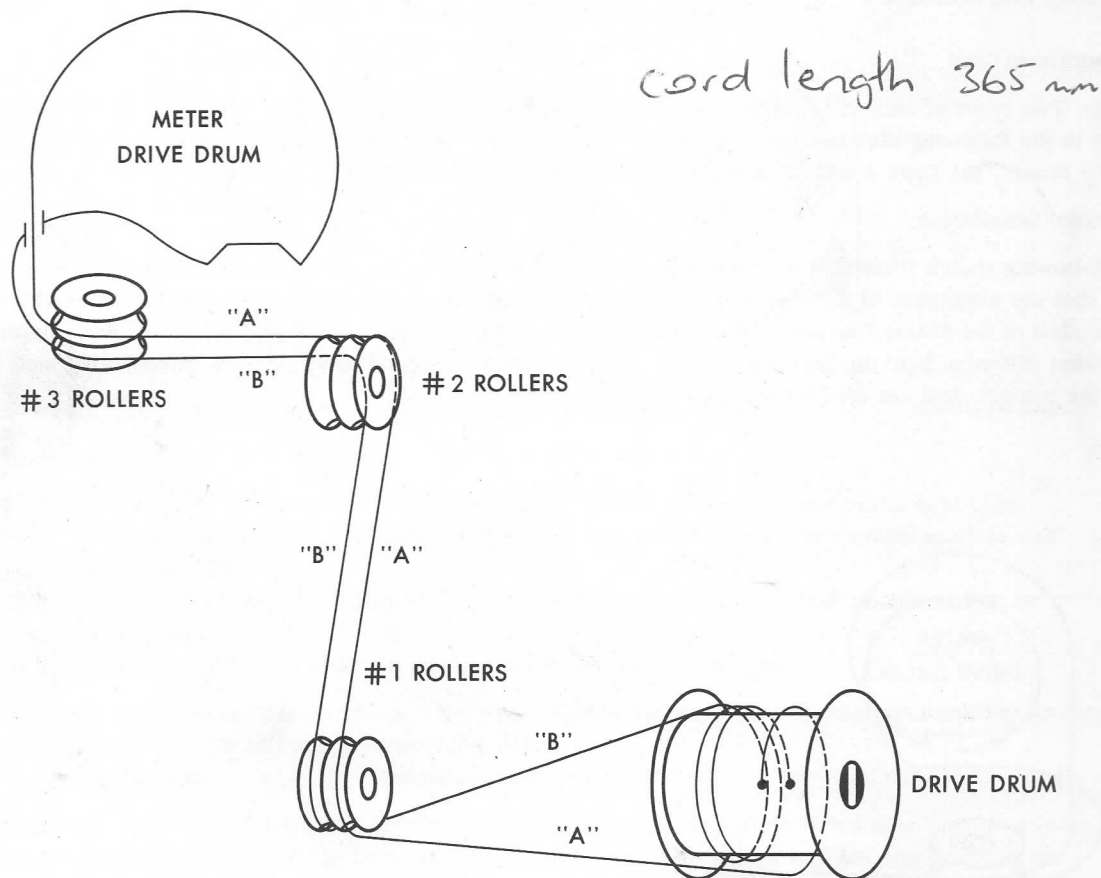

IV. HOUSING SPECIFICATIONS

28. Depressing exposure release should release film transport system at same time or slightly before tripping shutter.
29. Finder image should be discernible at low room illumination.
30. Tripod socket and exposure button should be threaded.
31. Back release button guard should open with a minimum of force and return with spring action.
32. Back latch should open with a minimum of force and return with spring action.
33. Back should fit case with a minimum of interference, latch securely and open partially under film pad pressure. It should be free of dents or imperfections sufficient to cause difficult film advance.
34. Film type indicator inner ring should rotate with sufficient resistance to prevent accidental movement during normal use.

V. SHUTTER SPECIFICATIONS

35. Shutter speeds should be within the following total time tolerances:

1 second	-	800 to 1200 milliseconds	1/30 second	-	28 to 42 milliseconds
1/2 second	-	400 to 600 milliseconds	1/60 second	-	16 to 24 milliseconds
1/4 second	-	200 to 300 milliseconds	1/125 second	-	8 to 14 milliseconds
1/8 second	-	100 to 150 milliseconds	1/250 second	-	4.5 to 8 milliseconds
1/15 second	-	55 to 82 milliseconds	1/500 second	-	2.5 to 5 milliseconds

36. Flash contact should occur as follows:

NOTE: Contact efficiency at least 75%.

- X - contact at full open shutter.
- M - 18 to 21 milliseconds from contact to full open shutter.

37. VXM lock lever should release selector lever and have spring tension sufficient to lock selector lever when released.

38. VXM selector lever should:

- a) Operate without binds.
- b) Not move into the "V" position when shutter is not set.
- c) When set to "V" returns to "X" position when the shutter is tripped.

39. Self-timer should operate for approximately 8 to 10 seconds.

40. Rotation of speed selector ring (black handles) should have detent action at each speed index and rotate diaphragm ring in opposite direction, without excessive binds or jamming, throughout the following ranges (check with lens removed):

NOTE: Make all initial settings with knurled wheel beneath shutter, and all rotation with black handles.

- a) from 1/500 second and f/1.9 to 1/4 second and midway between f/1.6 and f/22.
- b) from "B" and f/22 to 1/60 second and f/1.9.
- * c) from "B" and f/1.9 to 250 second and f/22.

* No detent action through green figure range except at "B".

41. Electrical circuit should be free of short or erratic continuity.

42. Shutter blades should be free of grease, oil or rust spots.

43. Lens lock lever should:

- a) Be free of binds or rough action and have spring tension sufficient to prevent accidental release of lens assembly.
- b) Retain the lens assembly securely.

44. Diaphragm controls should:

- a) Open the diaphragm blades fully.
- b) Allow diaphragm blades to close to any pre-selected opening.

45. Shutter

Since the shutter and all operating controls are identical with the Reflex S, service problems, disassembly (see note under Instruction 27) and reassembly are also identical.

Kodak