

Electrical  
Comms  
Data

ECD

DEC 2021  
VOL.20 NO.4

PP100007396

INSIGHTS  
2022



In partnership with





ACCURATE MEASUREMENT OF  
**FLOW, PRESSURE, LEVEL & TEMPERATURE**

Trusted German Engineering and Manufacturing



Quality Engineered Systems

JSG Industrial Systems | [jsgindustrial.com](http://jsgindustrial.com) | 1300 277 454





# INSIGHTS 2022

Welcome to the 2022 Insights issue where we've asked industry leaders to provide you with their views on what challenges and opportunities lie ahead. The issue combines content from three magazines in one – *Process Technology*, *Sustainability Matters* and *ECD*.

## CONTENTS

### CEO INSIGHTS

- 10 KATHRYN WOOD-ENRIQUEZ, POWERFLO SOLUTIONS
- 12 JASON VENNING, FIMER
- 14 DAVID SULLIVAN, ABB AUSTRALIA
- 16 STEPHEN ARMSTRONG, PACIFIC AUTOMATION
- 20 RAFAEL KOENIG, WEIDMÜLLER
- 24 MATT BROWNE, DONESAFE
- 26 ROSANNE JESSOP, PILZ AUSTRALIA AND NEW ZEALAND
- 30 BORIS GABIN, EMERSON AUTOMATION SOLUTIONS
- 32 JON MCGETTIGAN, FORTINET INTERNATIONAL
- 40 DAMIEN MCDADE, AVEVA
- 44 MARK FERGUSON, KAISHAN AUSTRALIA
- 46 LAUREATE PROFESSOR RAVI NAIDU, CRC CARE

- 
- 4 Plug it in: the electrification of everything
  - 18 Net zero within reach for Melbourne's buildings
  - 28 Flicking the switch to electric vehicles
  - 38 Australia's EV boom: what is driving its success?
  - 50 Smart building showcase: new JLL APAC headquarters delivers high employee satisfaction
  - 68 How waste management operators are dealing with new challenges to operate in residential areas as land conflicts arise
  - 79 Smart homes need to get smarter on energy use

40  
CELEBRATING  
YEARS

**wfmedia**  
connecting industry

**Westwick-Farrow Media**  
A.B.N. 22 152 305 336

[www.wfmedia.com.au](http://www.wfmedia.com.au)

Head Office  
Unit 7, 6-8 Byfield Street, North Ryde  
Locked Bag 2226, North Ryde BC NSW 1670  
AUSTRALIA  
ph: +61 2 9168 2500

#### Editors

Carolyn Jackson  
sm@wfmedia.com.au  
Glenn Johnson  
pt@wfmedia.com.au  
Amy Steed  
ecd@wfmedia.com.au

#### Publishing Director/MD

Geoff Hird

#### Art Director/Production Manager

Julie Wright

#### Art/Production

Colleen Sam, Krystyna Kappel

#### Circulation

Dianna Alberry  
circulation@wfmedia.com.au

#### Copy Control

Mitchie Mullins  
copy@wfmedia.com.au

#### Advertising Sales

##### Sales Manager

Nicola Fender-Fox – 0414 703 780  
nfender-fox@wfmedia.com.au

Liz Wilson – 0403 528 558  
lwilson@wfmedia.com.au

Sandra Romanin – 0414 558 464  
sromanin@wfmedia.com.au

Tim Thompson – 0421 623 958  
tthompson@wfmedia.com.au

#### Subscriptions

For unregistered readers price on application.

If you have any queries regarding our privacy policy please email  
privacy@wfmedia.com.au

Printed and bound by Blue Star Print

*All material published in this magazine is published in good faith and every care is taken to accurately relay information provided to us. Readers are advised by the publishers to ensure that all necessary safety devices and precautions are installed and safe working procedures adopted before the use of any equipment found or purchased through the information we provide. Further, all performance criteria was provided by the representative company concerned and any dispute should be referred to them.*

*Information indicating that products are made in Australia or New Zealand is supplied by the source company. Westwick Farrow P/L does not quantify the amount of local content or the accuracy of the statement made by the source.*

# PLUG IT IN: THE ELECTRIFICATION OF EVERYTHING

Glenn Johnson, Editor, Process Technology



There is no doubt that there will be challenges in achieving net zero GHG emissions, but a significant proportion of the task is possible with technologies available today.

The COP26 Climate Conference in Glasgow has loomed large in the news of late. Leaving Australian climate politics aside, on a global scale there have been some initiatives, summarised in a final statement from the conference:

*"We have seen a huge shift in coal, with many more countries committing to phase out unabated coal power and ending international coal financing....While on the world's roads, the transition to zero emissions vehicles is gathering pace, with some of the largest car manufacturers working together to make all new car sales zero emission by 2040 and by 2035 in leading markets. Countries and cities are following suit with ambitious petrol and diesel car phase-out dates."*

According to Oxford University's Our-WorldinData.org (Figure 1), energy consump-

tion accounted for 73.2% of GHG emissions in 2016, some significant elements being:

- Energy use in industry 24.2% (iron and steel 7.2%, other industries total: 17.2%)
- Energy use in transport 16.2% (road transport 11.9%)
- Energy use in buildings 17.5% (residential: 10.9%)
- The chemical and cement industries also accounted for a further 5.2 % through non-energy GHG emissions, while agriculture, forestry and land use accounted for 18.4% (livestock: 5.8%).

It is clear from these figures that the largest overall impact on GHG emissions will come from eliminating or reducing energy-related emissions in industry, transport and buildings.

At present there are really only two technologies that allow for energy consumption

with zero carbon emissions: electricity from renewable sources and green hydrogen (which also depends on renewable electricity). As a result, there is a growing 'electrification of everything' movement.

## Changes to the world's energy mix

According to McKinsey and Company, renewables could produce more than half of the world's electricity by 2035, at lower prices than fossil-fuel generation.<sup>2</sup> The resulting lowering of electricity prices, along with the falling cost of electric equipment and more stringent greenhouse gas (GHG) emission regulation, is expected to boost consumption of electricity in sectors, such as passenger vehicles and space heating, where fossil fuels have long been the standard energy source.



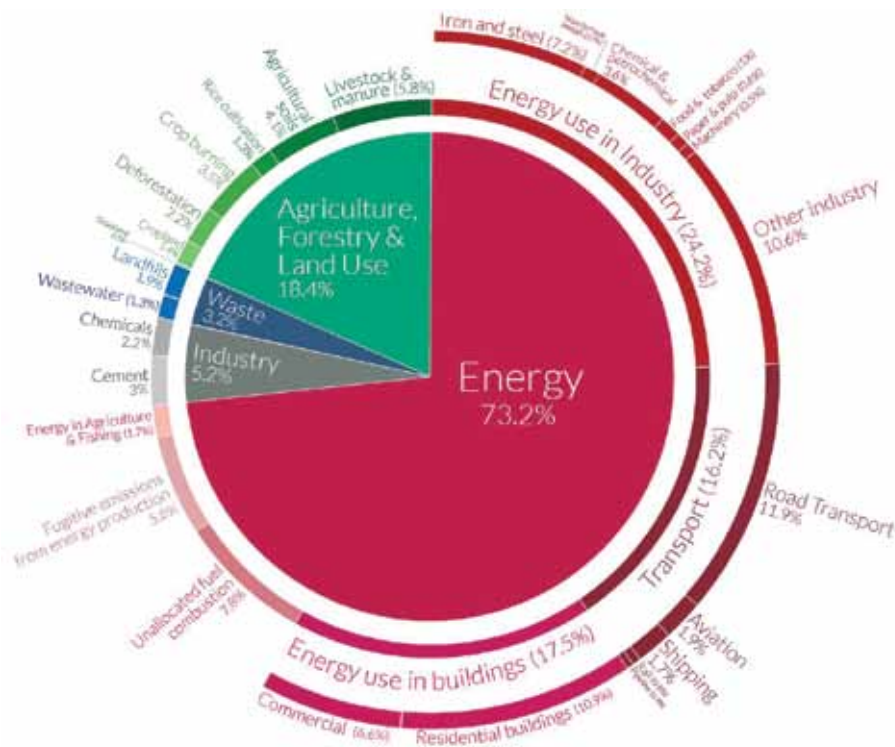

Figure 1: Global greenhouse gas emissions by sector 2016. (Source: OurWorldinData.org).

### The industrial electrification landscape

As seen in Figure 1, industry consumes more energy than any other sector, but only about 20% of the energy consumed is electricity. Most of the electricity that is used is to drive machines that move things and materials, such as pumps, robotic arms and conveyor belts. The remaining energy consumption is usually in the form of fossil-fuel energy.

Carbon-based materials are also used as feedstock, such as oil products from which plastics are produced and coking coal that is used to combine carbon with iron to produce steel — in other words, coal and oil are also used as an ingredient, rather than an energy source. In this sense, both coal and (to a lesser extent) oil will always have a place as a carbon source for the foreseeable future, but will be phased out as a source of energy.

Replacing — by electrification — the fuel that industrial companies use for energy has several benefits. Generally, electrically driven equipment is only slightly more energy efficient than the conventional option, but it has lower maintenance costs, and, in the case of (for example) an industrial boiler, the investment cost of the electrical equipment is lower. If zero-carbon renewable electricity is consumed, the greenhouse-gas emissions of the industrial site lower significantly.

McKinsey has estimated that of all the fuel that industrial companies use for energy, almost 50% could be replaced with electricity using technologies available today, including all processes that need to

generate heat up to 1000°C. About 30% of fuel consumption for energy is for processes that require very high temperatures, which include the production of steel, cement and ceramics. This will change, however. Only recently, Australian company Calix filed a patent for technology for the production of iron and steel with zero CO<sub>2</sub> emissions.<sup>3</sup> The company's technology can produce iron from iron ore in a hydrogen atmosphere between 600°C and 800°C — around 1000°C less compared to a conventional blast furnace. While the technology uses hydrogen in the kiln, the entire process can be renewably powered.

Calix says that while the use of hydrogen in blast furnaces is being tested, there will be limits on the amount of coal it could replace due to a reduction in the conversion rate of iron ore to iron.

### Mining is on an electrification binge

One industry that is a large consumer of energy is the mining industry, but over the last six months there have been numerous announcements by our major mining entities and industrial automation companies about mine electrification, particularly in the area of large haul trucks and underground mining vehicles.

BHP and Caterpillar have announced they are working to develop zero-emissions mining trucks, in order to support BHP's long-term goal of achieving net zero operational GHG emissions by 2050. Similarly, Komatsu has announced same and is working with Rio Tinto on a pilot of electric mine vehicles.<sup>4,5</sup>

In the underground mining equipment market, Hunter Region-based PPK Mining Equipment is developing battery-electric underground personnel vehicles with the aid of Ampcontrol, and retrofitting diesel drivetrains with BEV technology in other vehicles.

Of course you can't have large powerful haul trucks without large powerful batteries and the infrastructure to charge them efficiently. To that end, large automation and electrical companies are working on a solution. ABB for one has already announced high-powered fast charge technology to support large electric mining equipment, and compatible with all makes of haul trucks.<sup>6</sup>

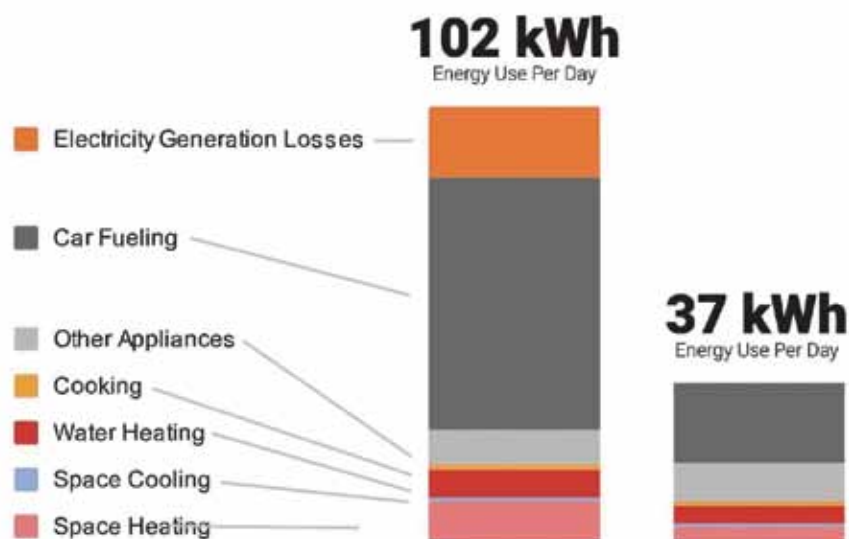

Figure 2: An electrified household is a cheaper and less wasteful future for us all. (Source: Rewiring Australia).

### The Rewire Australia movement

“Electrify everything” is also a motto being promoted here and in the US by Australian inventor and US government advisor Saul Griffith. Along with The Australia Institute, Griffith has published a discussion paper called *Castles and Cars*, which outlines how much Australian households could save if they electrified everything, including the cars, their household heating, their water heating and their cooking.<sup>7</sup>

According to the discussion paper, the average Australian household currently uses around 102 kWh of energy per day, spends \$5248 per year on energy-related costs and releases 11 tonnes of CO<sub>2</sub>-e into the atmosphere. Much of this energy use is due to the inefficiency of conventional fuels like natural gas and petrol for cars. The report claims that (along with solar panels on the roof and battery storage) changing to new electrical appliances and vehicles would drop the average daily household consumption to around 37 kWh — a nearly 64% net saving — while at the same time largely eliminating the household CO<sub>2</sub> emissions. The main reasons for this are:

- Electric vehicles charged by renewable energy sources consume only 25–35% of energy of an internal combustion engine-based vehicle (which are about 30% efficient).
- Water heaters or space heaters burning natural gas use about three times more energy than an electric heat pump. Heat pump technology as used in refrigerators and air conditioners typically needs only 1 unit of electricity to make 3–4 units of heat.

Additionally, electricity produced using fossil fuel power plants is also highly inefficient, with most coal plants only 25–30% efficient and gas plants around 40–45%. Renewable sources do not have the same thermal losses and toxic waste by-products — and of course no CO<sub>2</sub> emissions.

As with all major changes there are challenges with this course of action: problems caused by the change in the balance of energy generation in the power grid (through the addition of so many small generation sources) are proving to be a significant obstacle at the moment. But this is not a challenge that cannot be overcome with engineering know-how and the right investment.

In any case, making homes more energy-efficient will ultimately reduce the residential burden on the grid to the point where political debates over residential energy costs, fossil-fuel power generation versus renewables, and so-called ‘base-load’ power become redundant.

The problem with the Rewire Australia concept is that most households cannot afford to replace everything that is fossil fuel-based, as well as buy solar panels, battery storage and electric cars at today’s prices. Griffith therefore favours rebates and financing to make it more affordable. He says this needs to be a national priority, in the same way we built the Snowy Mountains hydroelectric scheme or spent money on the COVID-19 response.

“If we begin electrifying our homes with roughly 3% in 2022, 15% in 2024 and 40% in 2026, the spending required to pay for the capital cost difference (or break-even point) is predicted to be around \$12 billion in total,” according to the report, with the cumulative savings to be more than \$300 billion by 2035.

“For context, that’s just roughly 9% of what we are predicted to have spent on the COVID-19 response in the last two financial years, or roughly 18% of our defence spending in those two years.”

### Conclusion

There is no doubt that there will be challenges in achieving net zero GHG emissions, but a significant proportion of the task is possible — not with some as-yet undiscovered future technology, but with technologies available today, by electrifying as much as we possibly can.

### References

1. UN Climate Change Conference 2021, *COP26 keeps 5C Alive and Finalises Paris Agreement*, <<<https://ukcop26.org/cop26-keeps-1-5c-alive-and-finalises-paris-agreement/>>>
2. McKinsey & Company 2019, *Peak energy, peak oil, and the rise of renewables: An executive’s guide to the global energy system*, <<<https://www.mckinsey.com/industries/oil-and-gas/our-insights/peak-energy-peak-oil-and-the-rise-of-renewables-an-executives-guide-to-the-global-energy-system>>>
3. ProcessOnline 2021, *Calix files a patent for zero emissions iron and steel*, <<<https://www.processonline.com.au/content/business/news/calix-files-a-patent-for-zero-emissions-iron-and-steel-398345840>>>
4. ProcessOnline 2021, *BHP and Caterpillar to develop zero-emissions mining trucks*, <<<https://www.processonline.com.au/content/business/news/bhp-and-caterpillar-to-develop-zero-emissions-mining-trucks-431215927>>>
5. Rio Tinto 2021, *Rio Tinto and Komatsu partnering for zero-emission mining*, <<<https://www.riotinto.com/news/releases/2021/Rio-Tinto-and-Komatsu-partnering-for-zero-emission-mining>>>
6. ABB 2021, *ABB unveils game-changing ABB Ability eMine to fast-track transition to all-electric mines*, <<<https://new.abb.com/news/detail/82055/abb-unveils-game-changing-abb-ability-emine-to-fast-track-transition-to-all-electric-mines>>>
7. Rewiring Australia, *Castles & Cars: Savings in the Suburbs Through Electrifying Everything (Discussion Paper)*, <<[https://global-uploads.webflow.com/612b0b172765f9c62c1c20c9/615a513770739cc6477e67f4\\_Castles%20and%20Cars%20Rewiring%20Australia%20Discussion%20Paper.pdf](https://global-uploads.webflow.com/612b0b172765f9c62c1c20c9/615a513770739cc6477e67f4_Castles%20and%20Cars%20Rewiring%20Australia%20Discussion%20Paper.pdf)>>







## Industry has a new choice in Distribution Boards

Custom designed for the demands of Australian  
industry & purpose built for Siemens circuit breakers

**aps DB Eco**

**aps DB Essential**

**aps DB Ultimate**



**SIEMENS**

**RITTAL**

**Weidmüller**

**KATKO**

**BELDEN**

QUALITY | FLEXIBILITY | INTELLIGENCE | AS/NZS 61439 COMPLIANT

## ELECTRIC CAR CHARGER

ABB has launched its Terra 360 all-in-one electric vehicle (EV) modular charger that can deliver 100 km of range in less than 3 min. Suitable for refuelling stations, urban charging stations, retail parking and fleet applications, the device can simultaneously charge up to four vehicles with dynamic power distribution.

The charger has a maximum output of 360 kW and is capable of fully charging any electric car in 15 min or less, meeting the needs of a variety of EV users.

Available in Europe from the end of 2021, and in the USA, Latin America and Asia Pacific regions in 2022, the charger is designed to deliver speed and convenience along with comfort, ease of use and a sense of familiarity.

Its lighting system guides the user through the charging process and shows the state of C=charge (SoC) of the EV battery and the residual time before the end of an optimal charge session. It is also wheelchair accessible and features an ergonomic cable management system that helps drivers plug in quickly with minimal effort.

As well as serving the needs of private EV drivers at fuelling stations, convenience stores and retail locations, the chargers can also be installed on an organisation's commercial premises to charge electric fleet cars, vans and trucks. Because the chargers have a small footprint, they can be installed in small depots or parking lots where space is at a premium.

The chargers are customisable to suit branding requirements and there is also the option to include an integrated 27" advertisement screen to play video and pictures.

**ABB Australia Pty Ltd**

[www.abbaustralia.com.au](http://www.abbaustralia.com.au)



## HAZARDOUS AREA PRESSURE SWITCH/GAUGE

The Dwyer Series AT-3000MR/MRS ATEX/IECEX approved Photohelic switch/gauge incorporates a flameproof aluminium enclosure with texture epoxy coating that protects the device for use in hazardous areas commonly found in process or industrial applications.

The switch/gauge is designed for monitoring pressure, vacuum and differential pressure. Solid-state switches allow for switching in high cycle rate applications while extending the life of the sensor. These instruments can be installed in various process or HVAC applications globally because of the numerous pressure ranges and units available.

Well suited for industrial applications, the Series AT-3000MR/MRS also features a standard windowed enclosure cover that allows users the ability to visually verify changes in the process. Easy-to-adjust setpoint indicators are controlled by knobs located on the gauge face, accessible by opening the case after de-energising the instrument.

**Dwyer Instruments (Aust) Pty Ltd**

[www.dwyer-inst.com.au](http://www.dwyer-inst.com.au)

## INDUCTIVE PROXIMITY SENSORS

The Pepperl+Fuchs standard portfolio of inductive cylindrical proximity sensors is said to be characterised by a range of features to make installation and operation easy, safe and convenient. The use of updated end caps for fixed cable versions means that the sensor LED is now visible from all angles. The switch state is easily recognised simply by looking at the sensor, even during operation.

Standardised M12 connectors or fixed cables make installation quick and straightforward. Inductive proximity sensors are the preferred choice for the majority of applications requiring accurate, non-contact detection of metallic objects in machinery or automation equipment.

The standard inductive sensor range features smooth or threaded stainless housings; models with PVC, PUR or silicon cable; outputs in 2-, 3-, 4-wire DC, AC NAMUR and AS-Interface versions; LED status indication; and polarity reversal and short-circuit protection.

**Pepperl+Fuchs (Aust) Pty Ltd**

[www.pepperl-fuchs.com](http://www.pepperl-fuchs.com)





# Our capabilities

**CNC Machining**  
**UV Colour Printing**  
**Enclosure Customisation**



**Cable Assembly**

**\*\*\***

**Box Build**

**\*\*\***

**System Assembly**



**Ampec Technologies Pty Ltd**

Tel: (02) 8741 5000

Email: [sales@ampec.com.au](mailto:sales@ampec.com.au) Web: [www.ampec.com.au](http://www.ampec.com.au)





**POWERFLO**  
SOLUTIONS

EXCELLENCE IS OUR STANDARD

**HORA**  
REGELARMATUREN

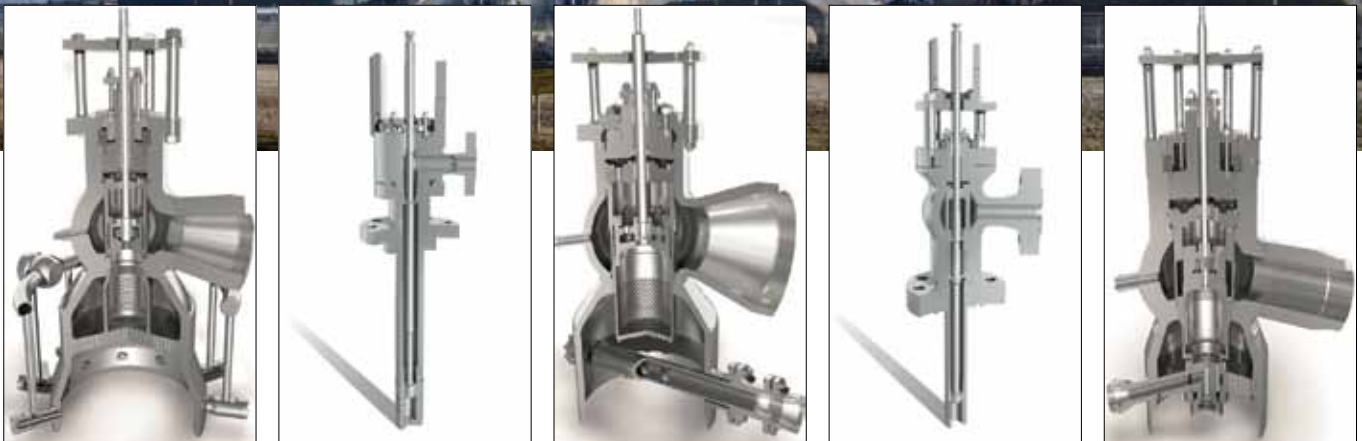

## **HORA TURBINE BYPASS VALVES, STEAM CONDITIONING VALVES AND DESUPERHEATERS HAVE NO EQUAL ...**

Engineered for the most difficult of applications, HORA POWER PLANT Control Valves are custom-built for long-term reliable service life, with unmatched turndown, ease of service (as a result of our unique capsule trim design) and control performance.

Whether it be for Coal-fired, Geothermal, CST, Biomass, WTE, Hydrogen or other types of Renewable Energy Power Plants, we can deliver a PRDS solution with proven reliability and genuinely, a low cost of ownership.

Proven in applications of over 500 Bar Differential Pressure drop, within a single Control Valve.  
Your cavitation and noise issues will be eliminated!

*Contact us at POWERFLO SOLUTIONS for local technical support and all aspects of After-Market service.*

**Total Engineered Control,  
Shut-off and Over-Pressure  
Protection Devices**

**1300 658 701  
sales@powerflo.com.au  
www.powerflo.com.au**



# KATHRYN WOOD-ENRIQUEZ

CEO AND MANAGING DIRECTOR, POWERFLO SOLUTIONS

## What opportunities do you predict for the growth of your industry in 2022?

Having been involved within this industry for more than 30 years and having witnessed, like everyone else, the greatest pandemic in my lifetime, I am personally committed to a high level of participation in the local manufacture of engineered control and safety valve products in Australia. Our team is focused on increasing our local manufacturing capabilities, so that we can be less reliant on imported products and provide more delivery flexibility on special material valves and custom-engineered designs. Everyone is being affected with supply chain issues, so we need to become more resourceful, as a company, an industry and as a nation.

We are also investing in infrastructure to support more local assembly, testing and after-market service — particularly in relation to the highly specialised types of valves that we sell, such as turbine bypass, anti-surge and very high pressure cavitation and noise control valves.

We also consider that there is a great opportunity for our industry as a whole in renewables. With a proven track record in the supply of valves and process instrumentation within a number of thermal solar, geothermal, biomass and hydrogen plants, we — together with our suppliers — can be counted on for application expertise and project execution.

## What are the three biggest challenges or threats facing your industry in 2022?

In these times, there is a serious threat to our industry: that decades upon decades of knowledge is being lost. Our greatest challenge is securing experienced and educated staff who are driven by achieving results and are committed to delivering a high level of technical support and service to our clients, from within an ever-diminishing pool of qualified engineers.

We need a raft of people to be ready to embrace the skill sets and application experience of those who have had the opportunity to 'practically' learn their craft. Now with Australia re-opening its international borders, it is crucial that we be granted the opportunity to employ qualified people in the field of chemical, mechanical, electrical and instrumentation engineering, from overseas.

The second challenge to some of us who operate within this industry is that many customers are no longer focused on specifying and procuring well-engineered, high-quality products. Rather, there has been an increasing trend of buying solely based upon the price, not understanding that a low price and high, or even good, quality do not go hand in hand. I believe that for the long-term prosperity of our country, we need to build reliable process plants that are designed for long-term operation. Decisions for procurement should therefore have a heavy weighting from the engineers who are employed in the business.

The third challenge is how we manage our prices to market, with the ever increasing cost of materials and exorbitant freight

costs. The whole world is living within unprecedented times, both as a result of the pandemic and also global political issues that are affecting supply chains. We have been thumped with air freight cost increases of up to sevenfold (and sometimes more) over the original prices of only four to six months ago. Who has to bear this cost? The buyer or the seller? Contracts have been negotiated and awarded, only to sometimes end up in a place where no one wants to be — back at the negotiation table.

Essentially, appreciating the need to place orders earlier (than usual) provides us time to evaluate other transportation methods, in order to achieve an acceptable outcome for both parties. A win-win situation is our aim.

## What are your thoughts about remote working technologies and supporting staff?

During the pandemic, we allowed most of our staff to work from home; with only essential manufacturing, assembly, service and stores staff being required to attend work. It was largely successful, with many employees stating that they achieved more from working in a 'quiet' environment, whereas, those working from home with young children around (and homeschooling) wanted to return to the office for peace and quiet. I believe that going forward, we will allow some of our staff (mostly those employed in engineering roles) to periodically 'work from home'. We have a very efficient IT network and can communicate with each other via a multitude of technology platforms. Still, this will never be permanent for us; there is no better way to achieve a cohesive and productive working environment than being together, face to face. And that goes for meeting with our clients and suppliers too.



*CEO and Managing Director of Powerflo Solutions Kathryn Wood-Enriquez has been in the engineered control valve industry for over 35 years. With an expansive knowledge of control valve design, sizing and application, Kathryn focuses on engineering long-term solutions for the most difficult of control applications.*





# Leading the way to a new energy future.

**The future is solar and we are ready for the new era of electrification.**

We are a leading global manufacturer of solar inverters and electric vehicle chargers. Our products and services are based on decades of experience in solar technology and the dedication and expertise of our specialist teams around the world.

Investing and working in the solar and e-mobility sectors is the right choice to ensure we build a better world to leave to future generations.

**Learn more: [fimer.com](https://fimer.com)**





# JASON VENNING

COUNTRY MANAGER – AUSTRALIA & NEW ZEALAND, FIMER

## What opportunities do you predict for the growth of your industry in 2022?

2020 was a record year for installing rooftop solar, and 2021 should end at a similar level, despite the impact of COVID-19 on the solar industry. There seems to be no stopping this upward growth trend in 2022. Commercial solar is growing strongly, with many large retail businesses like Woolworths and Coles committing to installing solar systems on their stores and distribution centres to achieve net zero by 2050. Investment in storage is also increasing, with more large-scale batteries being commissioned or under development for 2022 and beyond. This increase has been driven by a reduction in capital costs and grid strengthening and energy arbitrage benefits. Several state governments have also added incentives for electric vehicle ownership and usage, coupled with long-term strategies from vehicle manufacturers that will help accelerate the uptake of electric vehicle ownership in private and corporate fleets. The Future Fuels rollout's next stage will continue to boost existing public charging network infrastructure to help with long-distance travel and reduce perceived range anxiety issues.

## What are the three biggest challenges or threats facing your industry in 2022?

First is the challenge of getting the increasing amount of renewable generation integrated into the grid and available to the market. This will require significant investment in transmission infrastructure to relieve current bottlenecks and grid constraints to allow new generating plants to connect quickly and easily. Second is the policy issues around renewable energy. The policy disconnects between the federal level, where there is no coherent national policy, and states, which are going their own way, mean we have to spend more R&D resources complying with a range of different requirements instead of investing in ongoing product development to benefit the whole market. Lastly, we also strongly feel that battery storage needs a federal scheme like the Renewable Energy Target (RET) to drive uptake of residential and commercial batteries. This scheme would promote a greater reduction in our net emissions by 2030 and solve many grid stability problems.

## What impacts have the pandemic lockdowns had on your industry, and how does this affect your business strategies for 2022?

The pandemic lockdowns have caused the temporary shutdown of the construction industry in large parts of the country for a large part of 2021, which meant that many residential and commercial solar installations could not proceed. This has had a marked impact on sales during this time. The extended closure of our international borders has also cut off recruiting international talent, which has limited our ability to find new talent to grow our business. Only recruiting local talent from a small talent pool has made it very expensive to employ and retain people whose skills are in high demand. In 2022, we will be looking at using more virtual teams by employing people in APAC with the right skills and using them to augment the work of our local employees.

## How have the current international circumstances impacted your cybersecurity and/or supply chain management plans for 2022?

We have seen substantial cost increases and delays in international shipping as a result of the pandemic. We will be much more mindful of how we route our global freight from Europe to avoid highly congested ports such as Singapore. The global semiconductor shortage has affected production levels, leading to some delivery delays. For both of these reasons, we will be keeping higher inventory levels in Australia in 2022 to mitigate these issues while they hopefully resolve themselves during the course of the year. Cybersecurity will continue to be an increasingly important issue because solar inverters are now intelligent cloud-connected devices that need to be remotely monitored and controlled. As a European company, we have an obligation under GDPR to ensure that all customer data is kept safe, secure and only used for the purposes for which it was intended.

## What are your thoughts about remote working technologies, mandating vaccines and supporting staff?

The availability of Zoom, Microsoft Teams and other desktop videoconferencing tools has become vital during the pandemic. However, using these tools cannot and should not completely replace face-to-face interaction in an office environment. It is certainly harder to keep people engaged when working remotely. There are also health and safety concerns around remote working, even from home. A hybrid working model may well be an outcome of the pandemic. However, we have found there is still a strong desire from many employees to work in an office environment, side by side with their colleagues, with the added intellectual and emotional benefits derived from such interaction.

In regards to supporting our staff through the vaccination period this year, we have been fortunate to see a very high level of acceptance of getting vaccinated without using mandates. We have encouraged people to get expert advice and make informed decisions to protect their own health and the community, which has helped get those who may have been sceptical over the line.



*Jason Venning is the Country Manager of Australia and New Zealand for FIMER. FIMER is an Italian manufacturer of solar inverters and electric vehicle chargers. With more than 28 years' experience in the electricity, power generation and water infrastructure industries, he has extensive experience in leading teams and driving business performance as well as managing large-scale projects.*

# DAVID SULLIVAN

HEAD OF ELECTRIFICATION, ABB AUSTRALIA



## What opportunities do you predict for the growth of your industry in 2022?

For utilities and the construction, mobility and industrial sectors, among others, climate change and the responsible use of resources have moved to the top of the global agenda. The global consensus on climate change is driving demand for products, solutions and services that increase energy efficiency and reduce consumption of non-renewable resources, sustainable operations and products increasingly represent a competitive advantage in and of themselves.

Technological innovation will play a critical role in meeting these needs — improving people's living standards while simultaneously reducing their impact on the environment. We see huge growth opportunities in the implementation of smart, sustainable, digital technologies available today that can achieve energy efficiency and cut electric consumption and costs in industrial, commercial and residential environments.

### Smart mobility

In an effort to be more sustainable, cities today are looking for ways to get polluting internal combustion engines off the streets without disrupting the daily flow of people and goods. Going forward, e-mobility is the clear, clean choice. That is why ABB is active across the entire e-mobility value chain, offering a complete range of solutions for the electrification of buses, commercial vehicles, trucks, autonomous vehicles, automobiles, ships and railways. EV chargers can be integrated with domestic solar PV and energy storage through home automation systems to control light, heating and power demand to optimise energy usage from sustainable sources. This will require certified electricians to learn new skills in automation and wireless bus technologies.

### Smart industry

It has become essential for companies to reduce energy costs and shrink their carbon footprints as their stakeholders become

increasingly concerned about sustainability. Take mining as an example. Australia is leading the charge on the sustainability front in mining. We are seeing miners make strong commitments to the zero emissions target; for instance, FMG has brought forward their net zero target by 10 years to achieve this by 2030.

This greatly impacts decision-making around technology investment and modernisation. It needs to start with a definition of what an organisation's carbon footprint is, and what falls within their scope of decarbonisation. The next step is to examine the technology and what is currently possible to decarbonise. If companies graph this versus the benefit, the low-hanging fruit should

stand out — such as light commercial vehicles moving to electric.

ABB's whitepaper, 'The road to decarbonisation in Australian mining – How do we get to net zero?' goes into further detail about what the journey to decarbonisation looks like for the Australian mining and resources industries, and what practical steps companies within the sector can take now to prepare.

### Smart buildings

The world is going digital and the buildings segment is no exception. Applied to buildings, digital technology can increase overall transparency and help optimise building system performance for better occupant comfort and reduced energy use.

When we aim to minimise energy consumption, while still optimising the living conditions in buildings, we need to rethink the whole system from the ground up. Every possible way to save energy must be considered, and the most energy-efficient technologies and techniques must be applied. Together with renewable energy sources like wind and solar power, and energy regeneration technologies, it is possible for buildings to generate surplus energy, which will create extra revenue for the owners when the surplus energy is sold back to the grid.

An energy-efficient building with smart management systems can be a tempting dealmaker on many levels for many different target groups. In the commercial world, investors, developers, buyers and tenants are increasingly aware of how an energy-efficient building can boost the positive reputation of their company.

## Is your company working on decarbonisation strategies or net-zero goals to mitigate the effects of climate change in 2022?

The need for action on climate change is becoming ever more urgent. The hottest years on record have all occurred since 1998 and they are increasing in frequency. At the same time, over-



use of the earth's resources and environmental degradation are jeopardising the health and future prospects of huge numbers of people around the world.

With ABB's 2030 sustainability strategy, we are actively enabling a low-carbon society as well as working with our customers and suppliers to implement sustainable practices across our value chain and the lifecycle of our products and solutions. We are equally committed to driving social progress, along with our suppliers and in our communities.

By far the biggest impact we can have in reducing greenhouse gas emissions is through ABB's leading technologies, which reduce energy use in industry, buildings and transport — sectors that together account for nearly three-quarters of global energy consumption.

We have set ourselves the ambitious target of helping customers to reduce their annual CO<sub>2</sub> emissions by more than 100 megatonnes by 2030. This is equivalent to the annual emissions of 30 million combustion cars. For example, our variable speed drives for electric motors can reduce electricity consumption by up to 25%.

We also want to lead by example by achieving carbon neutrality in our own operations. We will do this by continuing to transition to renewable sources of energy, improving energy efficiency across our factories and sites, and converting our vehicle fleet to electric or other non-emitting alternatives. We have currently identified areas that can reduce our CO<sub>2</sub> emissions by at least 80%, and as technologies evolve, we will continuously seek opportunities to do more. In 2020, 32% of all the electricity used by ABB, was either purchased as certified green electricity or generated by our own solar power plants. These results represent an increase of nine percentage points from 2019.

To preserve the earth's resources today and for future generations, we are embedding circularity across our value chain even more systematically, by reducing waste, increasing recycling and reusability and making our products more durable. By 2030, at least 80% of ABB products and solutions will be covered by our circularity approach. We will also make sure that zero waste from our own operations is disposed of in landfills, wherever this is compatible with local conditions and regulations. Today, close to 40% of our sites have already stopped sending waste to landfills.

We are also leading the way when it comes to supporting our customers and industry on their route to decarbonations. One such example is by helping customers recycle and remanufacture old robots. Remanufacturing enables existing robot users to sell inactive or legacy robots to ABB with an attractive buy back service, rather than scrapping them or leaving them unused. Customers across the world are benefiting from giving old robots a new lease of life. Updating their robots with the latest technologies has helped boost flexibility and productivity, and by extending the lifetime of their robots, has helped maximise their return on investment.

## How is your industry preparing for artificial intelligence and/or advanced manufacturing?

Behind automation is AI — artificial intelligence. The starting point for bringing AI into manufacturing is data. Data is king — you can't have AI without data, and you need to digitalise your assets to get that data. AI is already making manufacturing safer, smarter and more efficient — and the future of this technology holds exponential potential.

At ABB we talk about it in terms of 'know more, do more, do better, together'. You're getting data, you're making decisions based on that data, you're optimising using AI and you're on the journey towards autonomy, when it all comes together seamlessly.

Manufacturers need to embrace the Internet of Things (IoT) to start on this journey. That means low-cost sensors and processors embedded in every part of your line, all connected and pumping data into the cloud. Humans simply cannot take in all that data, which is where the algorithms of AI come into play — it turns data into intelligent insights, and insights into action.

AI and learning algorithms revolutionise maintenance. Rather than time-based preventive or run-to-failure maintenance, sensors collect data which algorithms interpret to produce predictive analytics. AI gives us the capability to operate with condition-based or predictive maintenance, which improves uptime and savings two ways: avoiding unexpected shutdowns and planned shutdowns for maintenance that isn't needed yet.

ABB is developing advanced products, solutions and services that are radically reshaping the production landscape by making smart and sustainable factories of the future possible. ABB's portfolio enables manufacturers to respond to the increasing pressure for shorter product design cycles, the rise of mass customisation, and increased environmental, safety and compliance regulations.

Our suite of ABB Ability digital solutions and services uses sensors, network connectivity and data analytics to provide a real-time view into operations, enabling predictive maintenance, improved safety and reduced operating costs. And because ABB Ability uses the Microsoft Azure cloud as its integrated connectivity platform, our customers benefit from access to enterprise grade cloud infrastructure.

Digitalising production processes increases system reliability and throughput, reduces raw material and energy use and improves product quality. For instance, the virtual commissioning of drives and programmable logic controllers (PLCs) can cut project costs significantly while making more efficient use of engineering personnel.

To power the smart factories of the future, ABB offers a wide range of solutions for secure and efficient energy distribution. For example, our cloud platform can connect all of the electrical devices in a facility to the industrial internet, enabling precise information and control functions. Our compact, intelligent circuit breakers deploy integrated connectivity to link smartphones, tablets and PCs with data analysis tools in the ABB Ability suite in real time.

ABB's solutions for industry, just like its solutions for cities and infrastructure, leverage the latest digital technologies to deliver unprecedented levels of resource efficiency. Our world is a fragile one, with limited resources. These resources must be used sustainably and in a manner that minimises the impact of their use on the environment itself. Intelligent technologies offer the key to protecting the earth while enabling continued economic growth.



*David Sullivan is the head of ABB Australia's Electrification business. He leads a technology portfolio that covers the full electrical value chain from substation to the point of consumption, including ABB's electric vehicle charging infrastructure. David has more than 20 years' experience, both locally and internationally, in the electrical supply industry as it relates to utilities, process industries and minerals.*



**PACIFIC**  
AUTOMATION



# Solutions that work for you.

We deliver unique electrical solutions for industrial operators.

**We'll help you improve your processes.**

Since 1969, we've proudly supported industrial and mining operations across Australia.

We cover industrial automation, communication, electrical and lighting, and supply certified solutions for hazardous areas.

Work safely and efficiently with our tailored solutions. Visit our website today to browse our products and to learn more.



1300 881 876

[pacificautomation.com.au](http://pacificautomation.com.au)





# STEPHEN ARMSTRONG

CEO, PACIFIC AUTOMATION

## What opportunities do you predict for the growth of your industry in 2022?

Our industry is industry. As things pick back up across Australia, we're already seeing a growing demand for intelligent solutions. Our customers are recognising the benefits of technology that upgrades and expands plant and facility capabilities.

Across mining and oil and gas — two of our major sectors — there are some significant opportunities ahead for operators to increase efficiency and improve performance. Brownfields projects for upgrades and expansions are areas we're heavily invested in.

What we're seeing is an increasing movement away from obsolescence. Industry is moving toward solutions that last longer, that offer more value and address more challenges over their lifetime. By using modular technology that integrates with their existing systems, companies can extend the life of equipment.

## What are your thoughts about remote working technologies, mandating vaccines and supporting staff?

Adapting to remote working was challenging initially. Being a traditional business model, we did struggle in the beginning to keep our teams engaged across closed borders.

I personally found great value in connecting with my team through regular one-on-one calls. We've also made significant investments in technology and training, and this has allowed us to keep open lines of communication with our customers.

As a company, we've always had a huge focus on supporting our people. We're a family business. We value the community atmosphere that our people create both at work and outside. Flexibility is a given — we don't compromise on family time: it's in our core values.

We've had the overwhelming majority of our staff actively pursue voluntary vaccination ahead of any required mandates. It's fantastic that most of our team has made that decision, and I praise them for it.

## Is your company working on decarbonisation strategies or net-zero goals to mitigate the effects of climate change in 2022?

Since the start of the year, we've been working with an Australian Government initiative to roadmap our individual journey toward net zero. It's a great program, and one that provides us with access to industry networks and expert resources to help us along our journey.

This will assess all aspects of our business. We're currently in the process of calculating our carbon footprint, auditing our supply chain and starting to apply low-carbon solutions across our logistics. Ultimately, we're aiming toward a full-scale decarbonisation strategy and compliance in line with net zero.

We also want to be responsive to changing concerns and demands from our customers. That way, when targets and restrictions do start to affect industry, we'll be able to clearly showcase our low-carbon technologies on offer, and help move our customers toward a lower footprint, having done it ourselves.

## How is your industry preparing for artificial intelligence developments and advanced manufacturing?

It's safe to say that the majority of our customers have not yet started to utilise advanced tech. However, we're seeing great interest around AI and advanced manufacturing. Operators are starting to upgrade infrastructure and install next-generation communication devices, and are reconsidering key processes in readiness to integrate advanced technology. Example requests include migrating toward 5G networks and installing satellite communication infrastructure suitable for fleet automation. With regards to advanced manufacturing, the uptake of visual recognition systems and RFID equipment is providing a real clarity of vision for operators, through bringing data directly into their control rooms.

This emerging trend is one we've been responding to for a few years. Over the last decade, we've made conscious steps to partner with brand manufacturers that enhance our industrial IoT capabilities. We've made sure our technical support team is fully trained and able to support this technology.

## What are the potential challenges and outlook for the electrification of your industry?

A significant challenge ahead for industrial electrification exists around the unproven nature of much electrical equipment suitable for industry. That field data will come as adoption increases, but for now there are still questions around reliability and suitability.

Challenges are amplified for smaller companies. As an example, mining operators with small haul truck fleets may not find the same value in a movement toward electrification and automation.

Our challenge as service providers is helping our customers prepare for the future of industrial electrification, but at their own pace. Starting on the journey and preparation early will place operators in good stead for the challenges ahead.

Electrical costs must continue to decrease significantly before companies can make a complete switch to industrial electrification. As renewables grow over the coming decades, lower electricity prices combined with advances in technology will make industrial electric equipment more attractive and attainable for industry.



*Stephen Armstrong is the CEO of Pacific Automation, an industrial automation and electrical solutions provider. He previously held the role of General Manager and has a technical background as an electrical fitter. Stephen holds a BCom in Management and Marketing from Curtin University.*

*A prototype semi-transparent solar cell in development as an alternative to window glass.*

Image credit: Jaechoul Yoo/Eskaton Science.

# NET ZERO WITHIN REACH FOR MELBOURNE'S BUILDINGS



New modelling, on a scale ranging from individual structures through to neighbourhoods and an entire city, has shown that buildings in the City of Melbourne could provide 74% of their own electricity needs if solar technology is fully integrated into roofs, walls and windows.

Published in the journal *Solar Energy*, the research, led by members of the ARC Centre of Excellence in Exciton Science based at Monash University, together with collaborators at the University of Lisbon, is said to be the first of its kind anywhere in the world to model the viability and impact of window-integrated photovoltaics, alongside other solar technologies, at a city scale.

The results indicate that comprehensive adoption of existing rooftop photovoltaic (PV) technology alone throughout the city could radically transform Melbourne's carbon footprint, significantly reducing its reliance on grid electricity generated by burning fossil fuels.

Further gains could be made through the widespread deployment of emerging, highly efficient 'solar windows' and photovoltaic technology integrated in building facades.

The researchers hope that by using the modelling they have developed, policy makers, energy providers, construction companies and building owners will be able to optimise the PV potential of both new and existing structures.

The researchers compared Melbourne's 2018 electricity consumption to the electricity production that could potentially be achieved through fully and widely building-integrated solar. Consumption data from Melbourne's CBD was obtained from Jemena, CitiPower and Powercor distribution companies and was accessed through the independent Victorian research body, the Centre for New Energy Technologies (C4NET).

At city-scale modelling, they found that photovoltaics could provide 74% of Melbourne's building consumption needs. Rooftop solar would constitute 88% of this supply, with wall-integrated and window-integrated solar delivering 8% and 4% respectively.

Wall and window-integrated solar technology was shown to suffer less of a reduction in efficiency during winter months relative to rooftop solar, delivering more consistent year-round benefits and value.

The potential contribution of window-integrated solar rose to 18% at the neighbourhood scale, reflecting high building heights and window to wall ratios.

The researchers determined the annual solar radiation on Melbourne's building surfaces to identify suitable areas for PV installation, taking into account technical limitations and cost factors.

Detailed modelling enabled the incident solar radiation and PV potential of the urban areas to be simulated. A large range of factors had to be taken into consideration, including the impact of shadows cast by shading systems and balconies, as well as the performance characteristics of the various solar technologies.

Among other techniques, correlation and linear regression analysis were performed to identify the interdependency between urban form indicators and the annual PV potential.



The total area featured in the study is the 37.4 km<sup>2</sup> area of central Melbourne, of which 35.1 km<sup>2</sup> was built floor area in 2019, consisting primarily of residential and commercial buildings.

The results showed that the photovoltaics potential of this area is driven mainly by the possibility of adding further rooftop solar.

While blocks with high rooftop and wall solar potential are found across the city, the highest potential for window-integrated solar gains is in the city's high-density urban centres, such as the central business district.

"By using photovoltaic technology commercially available today and incorporating the expected advances in wall and window-integrated solar technology over the next 10 years, we could potentially see our CBD on its way to net zero in the coming decades," said lead author Professor Jacek Jasieniak.

"We began importing coal-fired power from the LaTrobe Valley in the 1920s to stop the practice of burning smog-inducing coal briquettes onsite to power our CBD buildings, and it's now feasible that over one hundred years later, we could see a full circle moment of Melbourne's buildings returning to local power generation within the CBD, but using clean, climate-safe technologies that help us meet Australia's Net Zero 2050 target."

Co-author Dr Jenny Zhou said: "Although there's plenty of policies supporting energy-efficiency standards for new buildings, we're yet to see a substantial response to ensuring our existing buildings are retrofitted to meet the challenges of climate change. Our research provides a framework that can help decision-makers move forward with implementing photovoltaic technologies that will reduce our cities' reliance on damaging fossil fuels."

First author Dr Maria Panagiotidou added: "In the near future, market penetration and deployment of high-efficient solar windows can make a substantive contribution towards the carbon footprint mitigation of high-rise developments. As the world transitions towards a net-zero future, these local energy solutions would play a critical role in increasing the propensity of PVs within urban environments."

**ARC Centre of Excellence in Exciton Science**  
<https://excitonscience.com/>



### Your benefits

- Full managed Fast Ethernet and Gigabit options, from 5 to 24-ports
- Fast ring-redundancy protocol with <30ms fallback
- Lite Managed switch options for cost-effective simple networks
- Wide options of SFP to tailor suit fibre optic runs easily
- Gigabit managed PoE switch options
- Redundant power inputs, and -40 to 75°C operating temperature as standard



For more information please visit  
[www.weidmuller.com.au](http://www.weidmuller.com.au)

**Weidmüller** 

## AdvancedLine Managed Switch Series

### Network switches built tough

The AdvancedLine managed switch series from Weidmüller provides a robust, secure, and cost-effective solution for industrial network management. The AdvancedLine switches can increase network availability by means of ring redundancy and security control mechanisms; and offer a range of diagnostic options for sophisticated automation networks. Integration into common fieldbus protocols such as Modbus TCP, Ethernet/IP and Profinet can be readily achieved, and they can be easily and intuitively setup via a web interface. With versions for Fast Ethernet, Gigabit and PoE as well as port sizes between 5 and 24 ports and a large variety of SFP options for fibre interfaces offers a solution fit for all requirements. Its high operating temperature range also means the switches can be used in challenging environments such as production applications or in the field.



# RAFAEL KOENIG

## MANAGING DIRECTOR, WEIDMÜLLER

### What opportunities do you predict for the growth of your industry in 2022?

Weidmüller Australia will celebrate its 50th anniversary in Australia in 2022. Today more than ever, longevity needs innovation, and we believe that there are tremendous opportunities to contribute to the electrical industry.

Our newly formed Klippon Engineering entity plays an active role to develop core strength in process industries and in particular green hydrogen. We also cannot ignore the fact that there is a reliance on traditional energy sources, and we are committed to providing the best possible technology solutions to assist the transition to new and renewable energies. Our Australian Renewable Energy Centre of Competence is driving innovation in solar, wind and utility-scale battery storage.

Considering Australia's newly found commitment to net zero by 2050, we expect the renewable energy sector to grow rapidly and are ready to service the local market.

We also believe that there will be a revival of the need to locally manufacture and reduce the reliance on sourcing finished goods from abroad. The pandemic has accelerated this need and now is the time for Australian manufacturing to invest in smart manufacturing solutions and advanced cloud-based IIoT that significantly reduce the needed economy of scale when it comes to batch quantities and the like that have in the past driven our production overseas.

As one of the few companies in our field that has retained and expanded its production capabilities, we believe Weidmüller is ideally positioned to take advantage of a growing demand for locally made products.

### What impacts have the pandemic lockdowns had on your industry, and how does this affect your business strategies for 2022?

In 2021 our industry, in general, experienced challenges related to materials and global transport issues. The shortage of computer chips combined with transport capacity shortages while experiencing a sharp increase in demand because of the bounce back after COVID, the industry has somewhat validated our long-term strategy of high availability and above-average investment in stock. Together with our distribution partners we have prioritised product availability and will continue to do so in 2022. Our close collaboration with academic institutions has helped us to build up the quality and competence of our workforce while the engagement with organisations such as the German Australian Chamber of Commerce (AHK) has enabled us to build networks with organisations that contribute to our ongoing progress in Australia.

### What are your thoughts about remote working technologies, mandating vaccines and supporting staff?

Remote working is here to stay. While many of us shared an initial reluctance at the start of the pandemic, if a business was func-

tioning when people worked from home, we soon found out that not only did the business remain functional but certain elements excelled. At Weidmüller we try to work together based on trust, and an extreme situation like the pandemic has shown that the investment we made in our company culture was repaid by our employees. So, in short, remote work is here to stay, and these days we leave it up to our line managers to discuss with each individual when to work from home or attend site.

We should not forget the colleagues who worked in production, the warehouse and the workshop and did have to come to the site. Their contribution was massive during the lockdowns, and we believe as a team we came out of the pandemic in better shape than going into it.

Public health advice to date states that vaccination is the most effective way to prevent the serious illness caused by COVID. While we have of course implemented measures such as mask-wearing, social distancing and optimised ventilation to help in managing the risk, we believe in a vaccination mandate. We take our duty of care for our employees seriously, and I believe it is impossible to protect unvaccinated employees effectively.

### Is your company working on decarbonisation strategies or net-zero goals to mitigate the effects of climate change in 2022?

Renewable energy has become a core business sector for us. This is in particular pleasing as it allows us to be part of the needed energy transition and contribute to our social responsibilities while at the same time creating meaningful employment and business models. We see ourselves as part of an industry community that embraces and drives the needed energy transition rather than waiting for politics to catch up. At Weidmüller Australia we have a long track record in photovoltaic, which we are currently expanding to include solutions for wind turbine maintenance, battery management systems and hydrogen. So, when it comes to decarbonisation, we feel we are right at the centre of it!



*Rafael Koenig is the Managing Director of Weidmüller Australia. He holds a degree in electrical engineering attained at the University of Paderborn, Germany and a master's degree in Business and Technology from the University of NSW, Australia. Rafael has more than 25 years of experience in automation technology and innovation management in Australia and Germany.*



## Lights-out robotic machine tending addresses labour issues



New England Union Company (NEU) is a family-owned foundry and machine shop that makes brass threaded pipe fittings for the plumbing and shipping industries in the US.

In the past, NEU had replaced outdated machine shop equipment with modern CNC machines, but manufacturing staffing remains a challenge in Rhode Island. To address labour shortages and longer cycle times, the company deployed a UR10e cobot from Universal Robots and an ActiNav bin picking system to run untended all night long. With ActiNav, NEU can increase output with the same number of employees.

Updating the shop from older lathes to modern CNC machines improved product quality but also increased cycle times, which impacted deliveries and didn't effectively use valuable machinists. NEU needed to increase output without adding manned shifts, and wanted to automate less-specialised tasks so that employees could be moved to higher-value roles such as setting up CNC machines and spending more time on inspection and quality.

The company's first collaborative automation project used a Universal Robots UR10e cobot and its built-in palletising function to pick parts from an organised tray to feed a gantry system for the CNC machine that performs threading, drilling and other operations. It took an employee about an hour to load the ordered grid on the tray, and the cobot could run for about eight hours unmanned.

This was an improvement, but the company needed a system that could run all night without an operator. NEU Vice President Brent Petit explored vibratory systems, but they couldn't meet NEU's repeatability requirements. That's when he was introduced to ActiNav.

"The advantage of the ActiNav system is that we can just bring a bin right over to the machine, set it up, and it will start picking right

from the bin," said Petit. "We don't need to have an employee standing there, picking up the parts and placing them into that pallet system that we were doing beforehand."

During day shifts, employees can quickly refill the bin as needed, then return to other tasks. At the end of the day, workers simply bring a full bin to the ActiNav system, check the standard, set it to run and leave for the night. The bin holds enough parts to keep the robot and CNC machine running unmanned all night long, and employees return in the morning to bins of finished product. They inspect the last part off the machine and take the finished bin to inventory, refill the raw-parts bin and let the robot keep running.

"The ActiNav system has a big bin with enough parts that fit in that bin where we don't have to worry about it stopping. It can run all through the night. We come back to finished parts, and it's a beautiful thing," said Andrew Lieffers, NEU Operations Manager.

The ActiNav system first performs a 3D scan of the bin, then the UR-10e cobot picks a raw part and places it onto a regrip fixture. The robot activates the fixture to vibrate the part so it's perfectly lined up to load into the gantry system that is the staging system for the CNC machine. At a signal from the machine, the robot picks a finished part from the gantry system, dunks it in water to rinse off the coolant and drops the part into a finish pan. Then the robot returns to the regrip fixture to pick the correctly oriented raw part and places it onto the gantry system to go into the CNC machine before starting the cycle again.

NEU is currently running 10 different parts on the ActiNav system, with the goal of running more than 30 different parts. ActiNav will run 24 hours a day, five days a week, allowing the company to increase output to meet demand with the same number of employees.

"We want our employees to be able to think through problems, and not just be assigned mindless tasks like pacing blanks on a tray," said Lieffers. "It also allows us to have inventory more readily available for our customers and to make lead times more predictable."

"I think the next steps will be looking at our entire factory from the foundry to the machine shop and seeing where else we can use automation. If you're not continuously implementing automation, you're falling behind."

**Universal Robots**  
[www.universal-robots.com](http://www.universal-robots.com)



# FOREVER YOUNG



The **Type A Range** of 19" cabinets provide rigidity, adjustability, the power to match existing installations, knock down supply and custom sizes available.



DESIGNERS & MANUFACTURERS  
OF 19" RACK SYSTEMS

**MFB's commitment to - and investment in - continuous improvement sees it as Australia's market leader for quality and innovative custom-built and off-the-shelf racking systems.**

Nothing is left to chance throughout the process - from materials, imaginative designs and use of technological advancements to no-fuss, no-stress and no-mess installations.

Yes, you can rely on MFB for consistency...and being one step ahead.



PROUDLY  
MANUFACTURING  
IN AUSTRALIA



AUSTRALIAN MADE  
MAKES AUSTRALIA



# Introducing VaxSAFE

## Workplace Vaccine & Test Status Tracking

Compliance Made Easy!

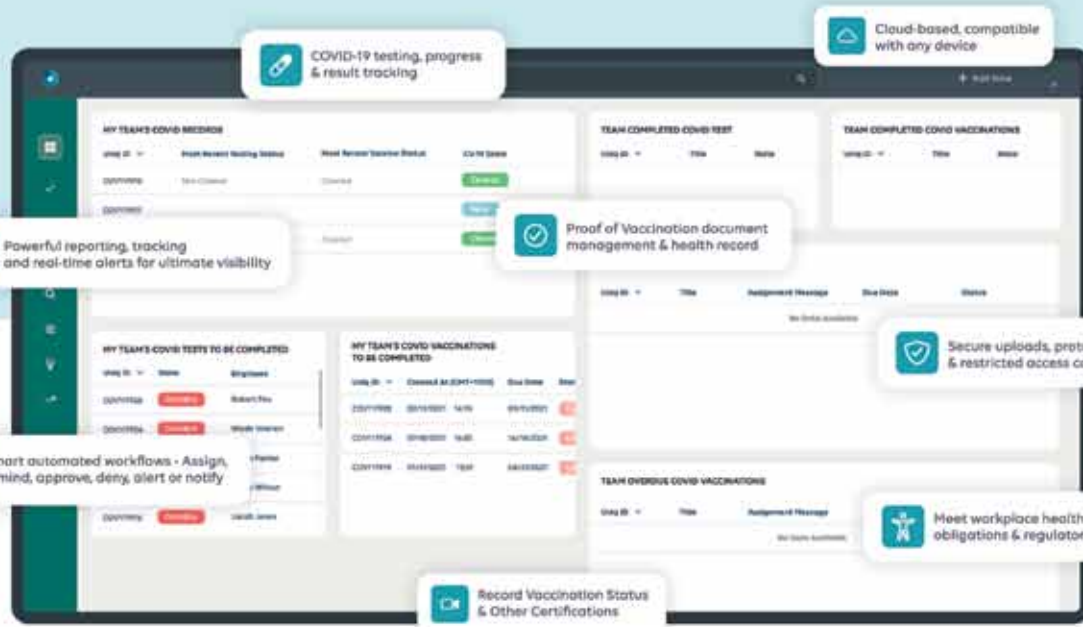

### Effortless Compliance, Adaptive Safety



On the go test submissions



Live vaccination status

### Is your business VaxSAFE?

VaxSAFE by Donesafe simplifies COVID-19 workplace tracking of vaccination and testing status all under one centralised cloud-based platform making return to work effortlessly compliant.

Trusted by Australia's Safest Workplaces.



Request a live demo & find out more  
[vaxsafe.donesafe.com](https://vaxsafe.donesafe.com) or call us on 1300 137 408





# MATT BROWNE

CO-FOUNDER AND FORMER CEO OF DONESAFE

## What opportunities do you predict for the growth of your industry in 2022?

Over the last few years, the environmental health and safety (EHS) software industry has increasingly adopted cloud-hosted environments as businesses moved away from on-prem solutions. Donesafe for example is purely an online cloud-only EHS offering used by some of the largest Australian businesses, and aligns well with a cloud-first approach that is now the standard for businesses as they reassess safety management platforms in the new year.

As lockdowns ease around Australia, many businesses are returning to the workplace. This has highlighted the importance of streamlining the return-to-work process, and ensuring businesses are aligned with OH&S and COVID-19 obligations. Given the tumultuous nature of the pandemic, this will be a big pain point that organisations will look to address in the new year. Implementing the right tools when managing workplace COVID outbreaks, vaccination and testing status will be essential to all organisations in 2022. Therefore this will be a big growth area for EHS software with businesses adopting systems for efficient COVID-19 management to ensure productivity and compliance is maximised.

Some of the other areas we are seeing growth across are safety training within the native e-learning space, occupational hygiene and risk management.

## What are the three biggest challenges or threats facing your industry in 2022?

Workplace safety, governance and adherence will be the three most important challenges businesses will need to address in 2022.

I think organisations need to ascertain how they manage workplace health and safety in a largely unpredictable environment, in the midst of a pandemic coupled with ever-tightening safe work mandates.

Safety leaders have the added challenges of making sure tight safety protocols are now adhered to outside the four walls of the 'new workplace' that can be virtually anywhere in the world!

## What impacts have the pandemic lockdowns had on your industry, and how does this affect your business strategies for 2022?

The pandemic has meant health and safety requirements are rapidly evolving driven by government mandates, safe work guidelines and legal obligations. Return to work post lockdowns has also meant organisations need to manage COVID outbreaks, vaccination and testing status of staff to ensure they are compliant. Furthermore, businesses have had to manage employees' personal feelings towards the pandemic and their safety, requiring a more flexible approach to working from home arrangements.

The new year will hopefully bring more stability for businesses to refine and improve safety measures using the right platforms that have positive impacts on adherence, productivity and com-

pliance. Due to our experience over the last two years, a bigger focus will be put on keeping the business agile, ensuring we are able to respond rapidly to change and adapt where needed.

## What are your thoughts about remote working technologies, mandating vaccines and supporting staff?

There has been an influx of remote working technologies that have hit the market over the last couple of years, with the pandemic really accelerating the maturity of these technologies for mass adoption. The success of remote work tools is ultimately measured on their productivity, simplicity and connectivity capabilities. Organisations need to ensure whatever toolset they choose will help drive workforce collaboration and seamlessly integrate with existing workflows/systems that already exist.

Vaccine mandates are a great example of the need for a robust centralised approach to managing vaccination and testing status without compromising productivity, compliance or employee privacy.

Supporting staff in this new dynamic and ever-changing workplace requires health and safety controls that go beyond legacy approaches. New workplace hazards, mental health, remote working, infectious disease are all areas that need to be added to the ever-growing list of keeping our most valuable assets safe no matter where they are in the world.



*Matt Browne is the Co-Founder and former CEO of Donesafe, a market leading global EHS SaaS platform with 1.5 million+ paying users. Matt took the business from launch in 2013 to the acquisition by HSI in 2020. He is on a mission to build greater technology efficiency and literacy.*



**Knowledge gives you a competitive edge!**

**PILZ**  
THE SPIRIT OF SAFETY

Whether you wish to deepen your knowledge in the field of safety control system design, understand the latest changes in safety standards, learn to conduct your own risk assessments or simply acquire further recognised qualifications in the field of machinery safety – with Pilz as your training partner, you are sure to reach your goal.

Check out our safety training programmes today.

- ▶ MachineSAFE Introduction & Comprehensive
- ▶ Risk Assessment Workshop
- ▶ Basis of CE Marking
- ▶ Lock Out / Tag Out – LOTO
- ▶ Safety Design incorporating AS4024.1503 (ISO 13849)
- ▶ Robot Safety & Human Robot Collaboration
- ▶ Management of Risk in Machinery Procurement
- ▶ Certified Machinery Safety Expert (CMSE®)

**Our practical expertise brings you success – safe & sound**



Melbourne • Sydney • Brisbane • Auckland

Ph: 1300 723 334 [www.pilz.com.au](http://www.pilz.com.au) [training@pilz.com.au](mailto:training@pilz.com.au)



# ROSANNE JESSOP

MANAGING DIRECTOR, PILZ AUSTRALIA AND NEW ZEALAND

## What opportunities do you predict for the growth of your industry in 2022?

Our most significant area of growth is predicted to be our services business. Pilz is renowned for being the gold standard in safe automation products, but we also provide supporting services such as training and safety consulting to help our industrial customers produce, procure, install, operate and maintain machinery safely. Industry standards are evolving rapidly, as is legislation. Establishing industrial manslaughter as a separate offence under safety legislation ensures that prosecutions can now extend to the highest levels of a corporation. It is an important reminder to senior management to instil a positive health and safety culture in their workplace.

We are seeing a rapid growth in needing these services in intralogistics, for example. We have just launched a new service specifically for making sure people are safe around AGVs. The 2020 publication of the ISO 3691-4 standard for automated guided vehicle systems (AGVs) and autonomous mobile robots (AMRs) was a reaction to the rapid development of new technologies in the field of automated vehicles. The ISO standard was long overdue, as its predecessor (EN 1525:1997) had been published 23 years previously.

The shoring up of our supply chains (ie, making more local) will also have a positive impact on our growth next year, with new production lines coming online with a number of our major customers. With every new production line comes investment in our products (automation and sensors) as well as our services (throughout the full safety lifecycle of the machinery).

## What are the three biggest challenges or threats facing your industry in 2022?

Global component shortages are deeply affecting the industry and are expected to last until 2023. We are receiving weekly reports from our factories in Europe and Asia, so that we can work closely and proactively with our customers to plan demand well ahead of when they need our products. We have never experienced this level of disruption in supply before. The component shortage is also driving up the cost to manufacture our products, and is compounded by the cost of freight also escalating tremendously. The sea freight index is above 600% and air freight index above 300% of pre-pandemic levels. The impact on our bottom line could be significant.

Ongoing border closures due to COVID-19 will continue to be a threat to our consulting business, as our consultants are based in Sydney and Melbourne. Whilst we can do some limited consulting virtually (desktop risk assessments), both ours and our customers' preference is to be onsite to perform safety assessments. We have not been able to get to our customers in other states for 18 months, and access next year remains uncertain, especially during the winter months.

The tight labour market is our other big challenge. There is a definite skills shortage in our industry. Combined with a predicted mass resignation wave, this makes talent retention a top priority for us in 2022.

## What impacts have the pandemic had on your industry, and how does this affect your business strategies for 2022?

The pandemic has certainly accelerated our own digital transformation journey. Finding new (digital) ways to keep in touch with our customers has been a priority. We have subsequently moved our full training portfolio online to provide resilience to border or office closures. The spin-off benefit of online training for our customers is great, as it enables a broader reach across a large geography such as Australia at lower cost to the trainees (ie, no flights and accommodation needed).

The pandemic has also forced us to acknowledge that to operate nationally we need a strong national presence. Our strategy for 2022 is to ensure we have a geographical spread of industrial safety expertise. We are working with our Systems Partners to upskill their staff so that they can confidently and competently represent us in locations where Pilz does not have an office.

## How is your industry preparing for artificial intelligence (AI) developments and advanced manufacturing?

Pilz managing partner Susanne Kunschert helped invent the name 'Industry 4.0', so advanced manufacturing is integral to Pilz' mission and value proposition. I also started my career, in the 1990s, using neural networks to build artificially intelligent control systems. Together we are helping many customers on their advanced manufacturing journey, from safely automating insulated lifting trucks to digitalising safety workflows in manufacturing. In order to support this, we are constantly looking to bring new skills into our engineering team. We will be hiring our first Digital Apprentice in 2022, a new qualification for school leavers that has us very excited. We believe we need to grow our own talent, especially in the current climate of rising labour costs and the significant skills shortage here in Australia.



*Rosanne Jessop is the Managing Director of Pilz Australia and New Zealand. An experienced strategic thinker who has a proven track record in leadership, partnerships and business performance, with experience gained from over 25 years' working in manufacturing, automation, digitalisation and machinery safety.*



# FLICKING THE SWITCH TO ELECTRIC VEHICLES

*Cecilia Duong*

**E**missions from road transport account for 10% of global emissions — and that number is rising faster than any other sector, as highlighted in the latest Global EV Outlook report.

Developed nations around the world, including the United Kingdom and Canada, have already pledged to phase out sales or registrations of new internal combustion engine cars by a certain date — but Australia has not.

## **Nowhere near the finish line**

Despite being one of the world's leaders in renewable energy research and innovation, Australia's vehicle emission standard is still based on the European Emission Standard five, which is now over a decade old. More than 80% of the global car market now follows 'Euro six' vehicle emission standards, including Europe, the United States, Japan, Korea, China, India and Mexico.

Beyond the failure to reduce regional air pollution, Australian standards have also fallen behind in mandating fuel efficiency

and hence lowering greenhouse emissions. Cleaner and more fuel-efficient internal combustion engine cars can assist in reducing both local air pollution and greenhouse gas emissions.

So how can Australia commit to zero emission vehicle goals if it's behind on global vehicle emission standards?

Associate Professor Iain MacGill, Joint Director of UNSW Collaboration on Energy and Environmental Markets, said despite Australia's move to support clean electricity initiatives, it hasn't made a serious effort to address transport related emissions.

"The transport sector is one of the continuing growth areas of Australia's emissions profile," he said.

"However, we've seen so many petrol-fuelled sports utility vehicles and twin cab utes being purchased that it seems likely that the average fuel efficiency of Australian cars is going backwards.

"We are actually making progress on cleaning up electricity, but really struggling with transport emissions, which continue to climb."





©stock.adobe.com/au/Blue Planet Studio

European countries, such as Iceland, Norway and Sweden, have all pledged to phase out the sales or registration of internal combustion engine cars.

### Chicken and egg debate

The pathway to zero-emission transport almost certainly requires electric vehicles fuelled by zero-emission electricity. Last year, less than 1% of new cars bought in Australia were EVs. That compares with more than 4% globally, almost 6% in China and nearly 75% in Norway.

Renewable energy expert Associate Professor Anna Bruce from UNSW School of Photovoltaics and Renewable Energy Resources said the absence of clear government policy is the biggest reason why Australia is lagging in the transition to EVs — making it difficult for manufacturers to focus on serving the Australian market.

“The catalogue of EVs available to Australian drivers is very limited because we don’t really have a clear policy on it. This

discourages car manufacturers from investing in producing left-hand drive versions of vehicles that are already available overseas,” she said.

“It’s also difficult to import second-hand vehicles into the country, and on top of that, there are additional road taxes for EV owners. So, it’s roadblocks like these that are impeding the adoption of EVs in Australia.

“It’s like the chicken and egg dilemma — but without proper policy and regulation, then demand for EVs will remain low.”

The same can be said about the network of EV charging infrastructure, said A/Prof. MacGill.

“Why should Australia invest in more charging stations if there are little EV sales? At the same time, why would drivers buy an EV if they’re concerned about the lack of charging stations?” he said.

“Australia’s an interesting mix in that we’re highly urbanised — so we take the view that our car should get us around town for 51 weeks of the year. But for the other week, we might want to drive all the way to another state.

“In most cases, nearly all the charging happens at home anyway but it’s for those special occasions where we need to drive long distances.

“The charging network can satisfy the number of current EVs but if that number were to double overnight, there will be challenges and we’ll need to roll out more infrastructure to support demand.”

### Electrify everything

UNSW PhD candidate Katelyn Purnell, whose research thesis explores electric vehicles and electricity grid modelling and planning, said we need to think bigger if Australia wants to meet its Paris Agreement commitments.

“While private vehicles make up a majority of transport use, there is a huge opportunity to electrify the entire transport network including bicycles, buses, taxis and rideshare and even ferries,” she said.

“Cross-modality transport is an important factor in reducing emissions because people are moving around differently — so policy discussions shouldn’t be limited to just motor vehicles.”

### The road ahead

There’s a lot to learn from how other countries have successfully adopted EVs.

If Australia wants to get serious about reducing emissions from transport, then it needs to start with a cohesive and holistic approach from both the state and federal government, Purnell said.

“If we look at Norway, they went with a portfolio method when introducing policy. Beyond initiatives such as reducing upfront capital costs, subsidies or access to special lanes, they signalled to the market that they were serious about this and there was no going back.”



We drive innovation that makes the world healthier, safer, smarter and more sustainable.

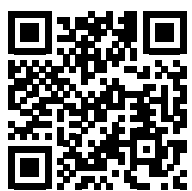

EMERSON. CONSIDER IT SOLVED.™



# BORIS GABIN

VICE PRESIDENT AND GENERAL MANAGER, EMERSON AUTOMATION SOLUTIONS

## What opportunities do you predict for the growth of your industry in 2022?

I am very optimistic about the growth opportunities we see in the industry, driven predominately by global demand for resources to support a sustainable future and meet net-zero targets. Capital investment in lithium, hydrogen and renewable energy projects in Australia is an indication of this trend.

Expansion of autonomous operations to address human safety and the current skilled labour shortage is another opportunity that will drive growth across the industry. Digital transformation is an enabler to support our customers achieving top quartile performance, across their capital investments and operations. Emerson Automation Solutions in Australia and New Zealand has secured key wins with these industry growth opportunities, as we align with our company's unified global purpose to "drive innovation that makes the world healthier, safer, smarter and more sustainable".

## What are the three biggest challenges or threats facing your industry in 2022?

The three biggest challenges I see across the industry are risk associated with cybersecurity, supply chain resilience and the shortage of skilled labour. Cybersecurity — or lack of it — is a major risk to business. It is essential that solutions deployed are aligned with the Australian Cybersecurity Framework and meet specific industry regulations to ensure company operations, data, assets, people and intellectual property are not impacted by global cybersecurity threats.

Supply chain resilience and the influence of global dynamics are impacting investment decisions and schedules. Local presence and support in major cities and key regional areas allows Emerson to mitigate some of these challenges as we continually review how we can better serve our customers and ensure service levels are met and exceeded. And with the pandemic closing international borders, the pool of skilled labour is limited. Coupling this with an ageing workforce, managing labour attrition through creative strategies is imperative to address immediate resource requirements to support the industries we serve.

## What impacts have the pandemic lockdowns had on your industry, and how does this affect your business strategies for 2022?

At the heart of our business is the principle of connecting with our customers and working hand in hand with them, but the pandemic has made connecting with customers more challenging. People are social creatures and we have seen the appetite to connect is stronger than ever. Whilst webinars and virtual meetings will be a part of our life going forward, we do see personal engagement coming back strongly but in a way that will differ from past engagements. The pandemic has accelerated digital commerce and companies are pivoting to business and interactive portals for B2B and B2C support and trade.

## What are your thoughts about remote working technologies, mandating vaccines and supporting staff?

Emerson has always been a company that drives technology adoption with our customers and internally. Our head office for Australia and New Zealand is in Melbourne, and we have offices throughout both countries. Many of our staff and our customers have been in lockdowns for a significant amount of time, so our team's quick adoption of remote working has provided positive benefits for us through the pandemic.

Digital technologies have been the key to ensuring we stay connected. As we review new work models, trust and empowerment are key as we drive flexibility with our employees by offering flexible work arrangements across Australia and New Zealand. We have supported all our staff throughout the pandemic, strengthening our focus on mental health day-to-day and training our staff on understanding their mental health.

## Is your company working on decarbonisation strategies or net-zero goals to mitigate the effects of climate change in 2022?

Absolutely: Emerson's commitment to sustainability is reflected in our Global Purpose: "We drive innovation that makes the world healthier, safer, smarter and more sustainable." Our environmental sustainability framework is designed to ensure greening of, greening by and greening with Emerson.

Our greening of Emerson roadmap includes significant reduction of emissions across our manufacturing and shared service facilities globally. Our greening by Emerson program involves working with our clients to help them on their roadmap to lower carbon-intensive operations. In Australia & New Zealand we have a well-developed program with many customers and have been working with industry bodies including the Australian Hydrogen Council.

Our greening with Emerson focuses on partnerships with industry, government and educational institutions to find and advance new technologies. We have some exciting announcements coming shortly with industry bodies and the education sector in Australia and New Zealand, and have already announced key partnerships across the globe.



*Boris Gabin is Vice President and General Manager at Emerson Automation Solutions, responsible for leading the business across Australia and New Zealand since 2016. Boris has broad international experience in general management, sales, business development and marketing across industrial automation industry. He is a critically thinking strategic leader, who cares for people and is down-to-earth.*



# Cybersecurity for ICS and SCADA

Protect Critical Infrastructure with Fortinet





# JON MCGETTIGAN

REGIONAL DIRECTOR, AUSTRALIA, NEW ZEALAND AND THE PACIFIC ISLANDS,  
FORTINET INTERNATIONAL

## What opportunities do you predict for the growth of your industry in 2022?

There is a clear opportunity in the critical infrastructure sector where operational technology (OT) devices are becoming more connected. Previously secured by virtue of being air-gapped, these devices are now connected to the internet and to corporate networks, creating an urgent need for them to be secured. These conversations are happening outside the IT department, which was traditionally responsible for security.

Also, with supply chain issues creating challenges for many manufacturers in the technology industry, opportunities will be created for those manufacturers who can meet demand. There have been some issues for manufacturers that need silicon for example, which forms a significant part of the technology market. This means that, while some vendors will struggle to ship products, those that plan in advance and do not use a just-in-time approach will be best-placed to fulfil customer needs.

## What are the three biggest challenges or threats facing your industry in 2022?

I see the three largest challenges as being the securing of OT systems, the securing of remote workers and meeting the rising challenges and costs of freight.

The Australian Government is moving to classify more industries as critical infrastructure, putting pressure on organisations in those industries to comply with legislation regarding their cybersecurity preparedness. Securing OT is challenging due to numerous factors. Chiefly, OT is usually legacy equipment with a decades-long lifespan and was never designed to support cybersecurity tools such as agents. Updating or patching this technology is usually impossible, especially because OT systems can't generally be taken offline to do so.

The leap in the number of people working from home due to the pandemic also created security risks for organisations that didn't have effective solutions in place. Attacks were created to leverage the confusion caused by the pandemic, and businesses had to move quickly to provision remote workers. The fallout from this will continue into 2022 as businesses try to work out how to secure a workforce that remains remote at least to some extent.

For technology manufacturers, the shortage of silicon and magnesium will make it difficult to meet market demand for new products. Meanwhile, the cost of freight is increasing as COVID-19 disruptions have made it difficult to process ships and cargoes in a timely fashion. Companies like Fortinet that manufacture their own products and operate with a six-month lead time will be better placed to cope with this challenge and continue providing products to customers as needed.

## What impacts have the pandemic lockdowns had on your industry, and how does this affect your business strategies for 2022?

The pandemic lockdowns meant people had to work from home, creating significant demand for security solutions that could protect remote workers, such as secure SD-WAN. The need for increased security has bolstered the industry, accelerating growth.

The spikes in cybersecurity attacks on OT infrastructure have heightened awareness of this critical area over the last 18 months. Fortinet is focused on delivering solutions that protect OT infrastructure in 2022 and beyond. Because the decisions regarding OT infrastructure are made at a global level, security vendors will require strong global relationships to ensure their security is embedded in the OT architecture. Fortinet is looking to lead the charge in this space.

## How have the current international circumstances impacted your cybersecurity and/or supply chain management plans for 2022?

According to IDC, Fortinet manufactured 59% of all security appliances entering Australia in the first half. Supply chain issues have increased costs, which means that the business has had to be prepared to adapt and take on more cost to avoid passing the full cost increase to customers. As a manufacturer, Fortinet is unlikely to be affected by supply chain issues because there is significant stock on hand and the business continues to build in advance.

## What are your thoughts about remote working technologies, mandating vaccines and supporting staff?

Fortinet was designed to be a remote workforce. At the height of the pandemic, Fortinet's purpose-built technical assistance centre (TAC) in Sydney transitioned to working remotely and it was completely seamless. In fact, quality of service increased during this time. Staff were provisioned with firewalls and other essential technology to make this happen.

The Fortinet Testing and Assurance Lab also enables live tests to be viewed remotely. The capability was conducted with a large enterprise customer during lockdown and the process was seamless.

Meanwhile, Fortinet has provided extensive support for staff members by running online sessions with educational and motivational speakers providing entertainment, and even yoga, via Zoom calls. The business provided care packages for customers and staff and conducted a wellness program with meditation and sessions on how to deal with anxiety.



*Jon McGettigan is the senior director of regional sales across Australia, New Zealand and the Pacific Islands for Fortinet. He is responsible for leading Fortinet's operations in the Australasian region, driving Fortinet's continued expansion and increasing the organisation's traction with large enterprises and services providers, as well as with the partner community.*



## EDGE AI GPU COMPUTING PLATFORM

The Neousys Nuvo-8108GC-XL is an edge AI GPU computing platform supporting NVIDIA RTX 30 Series GPU cards up to RTX 3080 and Intel Xeon E, 9th/8th-Gen Core processors.

Featuring thermal operation up to 60°C, support for shock and vibration up to 3g<sub>RMS</sub> and a wide-range 8–48 VDC power input design, the Nuvo-8108GC-XL is an industrial-grade edge AI GPU computing platform that can support vision inspection and intelligent video analytics.

To accommodate the latest RTX 30 Series GPU cards into the system and maximise its performance, Nuvo-8108GC-XL comes with an updated mechanical design offering improved heat dissipation.

Nuvo-8108GC-XL has an additional x8 PCIe slot (4 lanes) and one x16 PCIe slot (8 lanes) for developers to add on high performance or bandwidth-hungry expansion cards to extend functionality and achieve diverse applications, such as video analytics and deep learning vision inspection or 4G/5G communications via an M.2 expansion.

**Backplane Systems Technology Pty Ltd**

[www.backplane.com.au](http://www.backplane.com.au)

## APPLICATION WORKFLOW FOR DRINKING WATER ANALYSIS

The Thermo Scientific HAA9 Disinfection By-Products (HAAs) Application Workflow is designed to provide accurate and reproducible determination of haloacetic acids (HAAs) in drinking water samples.

Designed for use in municipal utility laboratories, contract testing laboratories and local or regional governing agencies performing water testing, the validated application workflow uses ion chromatography tandem mass spectrometry (IC-MS/MS) to achieve HAA analysis in drinking water in accordance with the US Environmental Protection Agency Method 557 (EPA 557).

The application workflow uses the Thermo Scientific Dionex ICS-6000 HPIC system and a Thermo Scientific Dionex IonPac AS31 column coupled with triple quadrupole mass spectrometry to deliver a fast, sensitive and simple method that has been developed for direct analysis of nine HAAs, bromate and dalapon in drinking water samples.

The MS detection method provides high sensitivity and makes it possible to directly inject drinking water samples, eliminating the complexity and variabilities of sample preparation. These method improvements allow time and cost savings for water testing laboratories and provide results that enable laboratories to more rapidly confirm the safety of drinking water.

**Thermo Fisher Scientific**

[thermofisher.com](http://thermofisher.com)



## AIR COMPRESSORS

Kaishan's scroll, fixed orbit, lubricated range of compact air compressors can provide benefits over the conventional piston-type compressors. Scroll technology has produced a compact air compressor with direct drive and dynamically 3D balancing that is said to deliver quiet, stable and energy-efficient performance.

With the added benefit of continuous load capability and an integral aftercooler to reduce moisture carryover, Kaishan says the scroll compressor can provide a compressed air supply with lower energy bills. The dynamically balanced, non-contact, fixed orbit technology can also result in longer element life.

The scroll compressor includes a digital control panel for ease and safety of operation. This provides operators with monitoring capabilities for all key compressor functions, fault detection and protection, and service due alerts.

Scroll OX series air compressors can provide higher output ratios to energy input and with fixed orbit direct drive there are zero transmission losses and no need to oversize the compressor to manage load cycles. The direct drive configuration also means there are no drive belts to wear and replace.

The scroll compressor is now available as a fully integrated, tank-mounted system complete with large 500 L receiver tank and optional built-in refrigerated dryer and air filter unit.

**Kaishan Australia Pty Ltd**

[www.kaishan.com.au](http://www.kaishan.com.au)





# The intelligent choice for compact automation

The family of Siemens SIMATIC S7-1200 controllers are the ideal choice when it comes to flexibly & efficiently performing automation tasks in the lower to medium performance range.

Efficient Engineering 

Innovative Design 

Technology Integrated 

Security Integrated 



Scan the QR code for more exclusive content!



NATIONAL DISTRIBUTORS OF  
**SIEMENS**

[apsindustrial.com.au/SIMATIC-S7-1200](http://apsindustrial.com.au/SIMATIC-S7-1200)

# 70,000 TONNES

OF OPPORTUNITY, AND LOCAL COUNCILS ARE SHOWING US HOW TO TAKE ADVANTAGE OF IT

The Tyre Export Ban came into effect on 1 December 2021 and Australia now has a challenge: what do we do with the 70,000 tonnes of whole and baled tyres we once sent offshore every year?

**T**he answer lies in the results of R&D projects, both completed and underway, being undertaken around Australia.

They are showing us how to view used tyres as a valuable resource and how to evolve processing technologies and business models to leverage it.

Many are being led by local councils, working with designers, manufacturers and construction operators, and funded by Tyre Stewardship Australia (TSA).

TSA CEO Lina Goodman said: "It's no surprise councils were one of the first to see this opportunity and are showing us the way forward.

"In terms of waste collection and recovery, they do the heavy lifting for us. They understand the risks to our environment and health; and community demand for sustainable solutions and a return on investment of rates paid."

## But first, we're going to feel some short-term pain

We've had 18 months to prepare for the ban and, under normal circumstances, tyre collection and recovery operators would have been ready to implement it with minimal disruption.

But these are not normal times.

In the wake of the pandemic, Australians have become more 'home centric' and new tyre sales have increased by about 30% over the past year.

There's also a global shipping crisis, which has left us short of containers. This means retailers and processors are struggling to get used tyres collected.

It's a perfect storm, increasing short-term risks such as:

- illegal stockpiling, dumping and mismanagement of used tyres
- the export of existing tyre-derived products (TDPs) reaching onsite EPA licence thresholds
- reduction in recovery rate of used tyres
- cheap, imported crumb undercutting domestic prices.

"The reality is that it will seem like we are taking a step backwards, before we can take a massive leap forward," Goodman said.

"There's no doubt it will be painful, but we have seen time and time again how Australians' entrepreneurial spirit and engineering ingenuity can kick in. And the rewards are there for the taking."

## New products and markets right on our doorstep

The list of tyre-derived applications emerging in Australia is extensive, and includes:

- spray seal
- blast protective concrete
- crumb rubber roads
- permeable pavement
- safety barriers
- alternative fuels.

There are surprising benefits as well. Recent work commissioned by TSA has found that tyre-derived fuel has a higher calorific value than coal and that greenhouse gas emissions would be reduced by around 20-30% for the same energy input.

## Councils are showing us the way forward: if you build it, use crumb!

Roads. Pavements. Sports grounds. Equine tracks. Playgrounds. Just some of the tyre-derived applications local councils are already using or exploring.

Pioneers include: Bendigo Council (Vic), Brisbane City Council (Qld), Central Coast Council (NSW), City of Canning (WA), Meander Valley Council (Tas) and Mitcham Council (SA).

Mitcham Council is part of Australia's largest trial of asphalt produced from recycled tyres, across six Adelaide council areas.

The trial is in collaboration with Adelaide-based Topcoat Asphalt and funded by TSA with the support of Tyrecycle Australia.

It is set to pay dividends for the jobs market, with a new asphalt manufacturing facility worth around \$5 million in Lonsdale, and the environment, with roads built for local conditions across metropolitan and country areas.

Procurement and ESG professionals, from public and private sectors, can find out more about practical opportunities to move through and beyond the Tyre Export Ban by talking to Tyre Stewardship Australia.

**Tyre Stewardship Australia Limited**  
[www.tyrestewardship.org.au](http://www.tyrestewardship.org.au)





Tyre Stewardship Australia is focused on driving a circular economy that contributes to a sustainable society, facilitates commercial outcomes and drives public awareness for end of life tyres. We can only do this with everybody on board and committed, from the consumer to government departments both locally and federally.

### **TSA IS FUNDING SOLUTIONS**

Let's make a difference by being custodians of our waste and turn this problem into a sustainable solution.



Use the QR Code to see the innovative tyre derived projects that have been brought to life through TSA funding.



[getonboard@tyrestewardship.org.au](mailto:getonboard@tyrestewardship.org.au)  
[www.tyrestewardship.org.au](http://www.tyrestewardship.org.au)





# AUSTRALIA'S EV BOOM

## WHAT IS DRIVING ITS SUCCESS?

*Stephane Marouani, Country Manager ANZ at MathWorks*

Over recent years Australia has fallen behind on the adoption of electrification compared to other countries.

Both from a political and general public perspective, the thinking has been that EVs are not adopted in Australia because of range limitation and the long distances people are often required to traverse.

However, the opposite is true — Australia is well suited to EVs, not only because its renewable energy capacity (mainly solar) is growing at a fast pace (with the ability to provide a cheap and easily deployable recharging network) but also because, in many situations, EVs make a lot of sense in major Australian industries.

For example, EVs such as utes or trucks for the mining industry are not only safer, especially in underground conditions, but also much cheaper to maintain — with significantly fewer mechanical parts subject to wearing in harsh conditions. Many mines in Australia are remote and already have plans for microgrids and operating their own renewable energy plant and storage batteries for their needs. In this particular scenario, using EVs makes absolute sense, and forestry or farming equipment fall in the same category. So, it is no surprise that electrification start-up companies are growing, with the need for specialised vehicles in mining (SafeScape), farming, construction and forestry (DC Equipment) and even aviation (MagniX).

### So, what is it about Australia that has led to this boom?

- **Engineering experience:** After some of the large original equipment manufacturers (OEMs) such as Toyota and GM either left Australia or reduced their local workforce in recent years, there is now a pool of very experienced automotive engineers who have decided to innovate and create their own startups, rather than relocating internationally.
- **History of renewable energy research:** Australia has been hosting the world's largest solar EV race, which has led to significant innovation in this market. For example, the first solar-powered luxury sedan from a company called Lightyear had its infancy in the Darwin to Adelaide Bridgestone World Solar Challenge.
- **Industry and university research collaboration:** Universities such as UTS and UNSW have been collaborating with businesses to drive electrification research and innovation, which means local innovations in electric vehicles came years ahead of those from mainstream EV manufacturers. The first battery-powered electric Holden Commodore, developed by Melbourne-based startup EV Engineering, was around as far back as 2012.





©stockadobe.com/au/U2MBrand

Although inductive, or wireless, charging is becoming more common for phones, smartwatches and other small devices, Lumen Freedom's wireless system for the Speedtail represents a unique solution for electric vehicles, according to Lumen Freedom general manager Rod Wilson and software team lead Radek Pesina.

For Lumen Freedom, the Speedtail project is just the start. Its production-ready system has the potential to transform automotive design, transportation and even the power grid as it currently operates.

The Lumen Freedom team envisions the adoption of WEVC systems by OEMs and infrastructure providers, leading to sweeping changes. One benefit will be the eventual reduction in the size of electric vehicle batteries.

"As wireless charging and accessibility to wireless charging becomes more commonplace, the forward projections are that battery sizes will be reduced because you won't need to carry as much energy onboard," Wilson said.

Wireless charging might also move Australia closer to vehicle-to-home and vehicle-to-grid scenarios. Wilson predicts that EVs will help power a house or become conduits to sell electricity back to the grid. Users just set battery storage to the desired retention level and hit a button from the car or house to engage energy transfer. The fully charged vehicle runs the lights, the TV and small appliances. For high-power home appliances, the system would revert to power from the grid.

Wireless EV charging is emerging just as autonomous vehicle testing ramps up. In August 2020, the US state of Michigan announced plans to explore building a 64-kilometre roadway between Ann Arbor and Detroit just for autonomous vehicles. Several major automakers agreed to provide input. The idea is to start with shared vehicles and then expand to personal and freight vehicles.

Wilson expects cities worldwide will designate areas like this for autonomous electric vehicles that can charge as they go.

"It's coming with a rush. We're looking forward to a big, bright, wireless future," he said.

### What does the future hold for the Australian EV industry?

Moving forward, there is likely to be an 'OEM-isation' of the EV industry. The industry will start to move from large players, such as Tesla, doing everything themselves (because as one of the pioneers of the industry, they had to invest in their own R&D — especially in battery development) to a more traditional model pushed by the traditional large manufacturers who assemble components from specialised suppliers.

There will be continued growth in Australian startups, innovating in areas such as battery technology, battery management, motors, controllers, wireless charging plates, solar charging roofs and so on. In addition, with volume increasing and technology improving, the EV industry will diversify from high-volume passenger cars to either specialised industry-focused vehicles or even restomod electrification. For example, more and more small suppliers, including in Australia, provide crate electrification conversion to either classic cars or industry-specialised vehicles.

Australia has a unique combination of engineers and researchers who can combine experience and expertise in electrification, automotive and industry. It does not seem likely that there will be a major car manufacturer coming back to Australia anytime soon, but certainly it could become home to a thriving EV supplier and specialised EV industries, thanks to the country's engineering excellence, unique needs and potential.

**MathWorks Australia**  
[au.mathworks.com](http://au.mathworks.com)

- **Overlap with motorsports:** Automotive suppliers such as MOTEK are increasingly transitioning their motorsport racing experience across to the electric vehicle industry.
- **Funding and investment:** The importance of funding to support the industry should not be underestimated. ARENA (the Australian Renewable Energy Agency) has been supporting electric vehicle innovation with the investment of a \$200 million+ fund targeting charging technologies and infrastructure.

One example of an Australian business making waves in the EV industry is Lumen Freedom.

### Wirelessly charging McLaren's fastest road car

The McLaren Speedtail Hyper-GT is the British auto manufacturer's fastest road car ever. Near the end of testing, a prototype of the sleek gas-electric hybrid sports car hit 403 kilometres per hour at the Johnny Bohmer Proving Grounds, NASA's runway in Florida. Specs for the 2020 production model say that it can go from zero to 300 kilometres per hour in 13 seconds.

To charge the lightweight battery whenever the aerodynamic three-seat vehicle isn't in use, McLaren partnered with Lumen Freedom to use its wireless electric vehicle charging (WEVC) system. The Speedtail is the first vehicle in the world to incorporate it.



# Improve your sustainability with industrial software

## Discover how your company can reduce waste and improve energy efficiency

Businesses around the world are prioritising sustainability to reduce their impact on the environment and reach net zero. Tightening regulations require a new way of thinking, in order to make these goals a reality.

AVEVA provides world-class industrial software tools to help transform operations, enhancing energy efficiency, reducing waste and driving circularity. Working together, we can accelerate a greener more sustainable future.

Find out more at [aveva.com/sustainability](https://www.aveva.com/sustainability)





# DAMIEN MCDADE

VICE PRESIDENT AND HEAD OF PACIFIC MARKETS, AVEVA

## What opportunities do you predict for the growth of your industry in 2022?

We recently commissioned a survey which found nine in 10 companies are expected to accelerate their sustainability activities over the year, as business recognise their role in tackling climate change. And technology is at the heart of this transformation, with four in five leading industries increasing their digital investment in order to drive sustainable business models. Technologies that we already have in place today could help us achieve 70% of the 169 targets underpinning the UN Sustainable Development Goals\*.

\*[https://www3.weforum.org/docs/Unlocking\\_Technology\\_for\\_the\\_Global\\_Goals.pdf](https://www3.weforum.org/docs/Unlocking_Technology_for_the_Global_Goals.pdf)

## What are the three biggest challenges or threats facing your industry in 2022?

The ability for industries to incorporate sustainability initiatives across their operations will be a major challenge. Those with end-to-end transparency of their complete value chain will have the visibility to adapt and optimise operations, to drive the circular economy and minimise their carbon footprint. Utilising technology and an integrated software strategy, feeding data insights into operational and governance reporting will be crucial in ensuring agility and efficiency for sustainable industries.

Another big challenge is the energy transition. To ultimately achieve net-zero, companies will need to move quickly to integrate renewables into their business models to offset their operations by deploying solar, wind, hydrogen and other alternate energy sources. Again, technology enablement plays a key role here, with highly digitised operations that provide insights into efficiency, reliability and reporting critical to achieving these ambitions.

An estimated 70% of new value created in the economy over the next decade will be based on digitally enabled platforms. But knowing where to start is vital, in order for both greenfield and brownfield projects to remain sustainable, viable and profitable for the long term. Leveraging technologies such as AI as well as digital twin and data platforms at a much earlier stage is critical in accelerating a sustainable operating model.

<https://www.weforum.org/agenda/2019/09/technology-global-goals-sustainable-development-sdgs/>

## What are your thoughts about remote working technologies, mandating vaccines and supporting staff?

The pandemic has changed the way we work. Organisations had to find new ways of working, and fast. Technology such as the cloud provided multi-site view of performance and unified teams to monitor plants and remain agile — without being onsite. Companies continuing to adapt remote working strategies are deploying cloud solutions which support net-zero ambitions, consolidate industrial data and provide real-time visibility of energy usage and sustainability impacts. Cloud is also increasing productivity through collaborative, remote and agile working patterns, with

up to 25% gains in workforce efficiency, while enhancing morale and wellbeing.

We recently introduced a subscription approach, allowing customers to maximise the allocation of the software they choose, which minimises their footprint by avoiding multiple distributed on-premise deployments with low utilisation.

## How is your industry preparing for artificial intelligence (AI) developments and/or advanced manufacturing?

Technological applications such as AI, IoT and machine-to-machine communication will continue to redefine the sustainable industries of the future.

A recent study by Microsoft and PwC UK demonstrates that using existing AI applications across agriculture, energy, transport and water could conservatively boost global GDP by 4% by 2030 — contributing up to US\$5.2 trillion to the global economy — while at the same time reducing global greenhouse gas emissions by 4%, which is equivalent to the projected 2030 annual emissions of Australia, Canada and Japan combined.\*

AVEVA has partnered with Schneider Electric to co-develop lean management software for their global smart factory program. The project was focused on digitally transforming the operations for over 100 discrete manufacturing sites around the world, with over 20% in energy savings achieved at select sites, with 377 tons of CO<sub>2</sub> reduced across the world. By empowering teams with real-time holistic insights into operations, and automating processes across the facilities, in addition to energy savings, downtime was reduced by 44%, with significant productivity enhancements and a 40% increase in on-time customer deliveries.

\*<https://www.pwc.co.uk/services/sustainability-climate-change/insights/how-ai-future-can-enable-sustainable-future.html>



*Damien McDade is the Vice President and Head of Pacific markets for AVEVA. Damien focuses on strategic direction, revenue management and market development of the entire AVEVA portfolio across the Pacific markets. His career spans more than 20 years in technical and commercial roles, having held various leadership positions in Schneider Electric, which merged with AVEVA in 2018. Damien holds undergraduate qualifications in Mechanical/Electrical Engineering and a master's degree in Management. Damien also holds a Master of Business Administration – MBA from Victoria University.*

# INDUSTRY 4.0 IMPLEMENTATION

Futureproofing workflows  
and supply chain  
management in factories



**Those manufacturers who had integrated IIoT technologies into their operations before the onset of the pandemic were less affected by the resulting disruptions.**

**T**he instability and disruption brought on by the COVID-19 pandemic exposed vulnerabilities in the Australian manufacturing sector. These primarily relate to issues around labour shortages and volatile supply chains.

Less affected by these widespread disruptions were those manufacturers who had integrated Industrial Internet of Things (IIoT) technologies into their operations before the onset of the pandemic.

The pandemic has seen a high demand for the IIoT to help ensure business continuity and better remote monitoring. In addition, it's been used to reduce the risk of COVID-19 outbreaks by allowing staff to work from home and to practise safe social distancing.



The members of the Open IIoT Group, a cohort comprising of some of Australia's most prominent automation companies such as SMC Corporation ANZ, Beckhoff Automation, NORD DRIVESYSTEMS, Balluff, ZI-Argus and KUKA Robot Automation, observed a spike in those seeking Industry 4.0 implementation on the factory floor as the pandemic wore on.

## Rethinking supply chain management

Borders closing and countries going into lockdown exposed the vulnerability of global supply chains and the need to 'reshore' manufacturing by strengthening local supply chains. This enhances local capabilities and protects the sector against future disruptions.



Future-thinking manufacturers are decentralising their production, building up a network of second-source suppliers, increasing their local stock and working on continuously improving their supply chain.

To improve their supply chains, manufacturers are encouraged to re-evaluate their current systems and the ability of these systems to adapt to rapid changes. The strongest supply chains are functional, digital and crucially, flexible.

Industry 4.0 implementation, along the supply chain and in the digitalisation of processes, promotes flexible manufacturing and helps meet increased demand from local customers. The challenge of changing a production line to produce more units, multiple variations or a completely different product at a rapid speed has called for the consideration of modular and scalable production lines.

A supply chain that is flexible enough to respond to changes and react to production demands requires traceability and real-time visualisation. Industry 4.0 enabled technology such as RFID systems, barcode information and software integration into ERP systems are a critical part of achieving this goal and can be implemented relatively easily.

### Futureproofing workflow with automation

In the context of the manufacturing sector, 'workflow' refers to the series of activities that are necessary to complete a task. Each step in a workflow has a specific step before it, and a specific step after, and there are various workflows across the entire manufacturing supply chain.

To avoid costly disruptions, it is necessary that the workflows be as efficient and resilient as possible to ensure continued operations and production. The most significant threat to workflow in Australia is labour shortages due to employees who either lack the skills or the desire to perform their tasks in the workflow. This challenge looks set to continue even once the pandemic is under control, with labour shortages affecting every sector.

One possible 'futureproof' solution involves fully automating manufacturing processes. Certain industries, such as those in the distribution of fast-moving consumer goods (FMCG), have been using fully automated warehouses for many years, with automation proving to be far more reliable and timelier than those using traditional manual pick-and-pack methods. By harnessing the power of live-data and automated picking machines, the process of getting goods out the door, safely and accurately, benefits both the consumer and the supplier.

In manufacturing, automation via the use of robotics has become a relatively easy 'go-to' to improve production, address labour issues and help companies stay competitive. Increasingly affordable and simple to program, collaborative robots have stepped up to the plate, performing flexible movements that can replace the boring and monotonous tasks previously done by people. The beauty of this type of automation is its ability to offer flexibility, as the same cobot can be used for multiple functions. Automation also allows for the possibility of 24/7 operations, without having to consider workforce management or overtime costs.



### About the Open IIoT Group:

Open IIoT is an initiative of some of Australia's most prominent automation companies — SMC Corporation ANZ, Beckhoff Automation, NORD DRIVESYSTEMS, Balluff, ZI-Argus and KUKA Robot Automation. It was founded with the mission of delivering valuable, efficient and easy-to-understand information on Industry 4.0, IIoT and other related topics to end-users and the broader manufacturing industry. Open IIoT industry experts break down the jargon and tackle real-world automation concerns to help unlock IIoT opportunities for commercial value — and ultimately advance Australia's economy through smart manufacturing.

### How to get the ball rolling

The wide range of IIoT solutions available can be tweaked to suit the individual needs of a manufacturer. However, before supply chain and workflow challenges can be addressed, manufacturers need to identify a simple starting point for Industry 4.0 implementation.

We suggest following these seven steps to get the ball rolling and start sooner than later:

1. First, consult with Industry 4.0 experts to get a better understanding of what the process will entail, and the costs involved.
2. Identify the areas in your current processes that will directly benefit from an Industry 4.0 solution and create KPIs for these areas to measure the success of the implementation.
3. Generate a scope of work for implementation and break it into phases, with each successful phase leading on to the next.
4. Engage Industry 4.0 experts to implement these phases and monitor changes in each area.
5. Educate existing staff members on the purpose of implementation and the tools needed to use the solution.
6. Continue to measure to ensure the solution is still making an impact on the process and production.
7. Finally, be flexible when it comes to budgeting for an implementation — in time these solutions will pay for themselves. Consider an operation costing model to support ongoing development and implementations rather than a traditional capital costing model.



Open IIoT  
[www.openiiot.com.au](http://www.openiiot.com.au)

# BIG AIR POWER



**UP TO 50% ENERGY COST SAVINGS**

## for Australian Industry

Kaishan's revolutionary range of PMV Rotary Screw Compressors deliver up to 50% energy cost savings over conventional compressors with equal or greater output.

From 250 to 15kW, these advanced machines utilise systematic optimisation of the airends through permanent magnet drive motors and variable speed drive technology to achieve higher efficiency at all operating speeds.

Advanced 2-Stage technology generates more air and ensures longer bearing life.

- Controlled air output to meet demand
- No start-up spikes and cost penalties
- Reduced part load energy consumption
- Significantly lower noise levels
- Lower maintenance requirements

### WE HAVE THE RIGHT COMPRESSED AIR SYSTEM FOR EVERY APPLICATION

From heavy industry to small workshop applications, we offer energy efficient compressors backed by 24/7 Australia wide support and service.



**KAISHAN COMPRESSORS**  
National Sales and Service

**1300 098 901**

[www.kaishan.com.au](http://www.kaishan.com.au)



**KAISHAN**  
Engineering the Future



# MARK FERGUSON

CEO, KAISHAN AUSTRALIA

## What opportunities do you predict for the growth of your industry in 2022?

As Australian industry recovers from the effects of COVID-19, there is a huge emphasis on reducing energy costs associated with running plant and equipment. Pressures are also mounting in keeping pace with carbon reduction and environmental issues. With the cost of generating compressed air the highest annual energy cost in many industries, the compressed air industry worldwide is striving to find efficiency improvements in order to be a provider of power now and into the future.

With international chain constraints, opportunities for growth in Australian manufacturing will create a demand for compressed air equipment that can keep up with new technologies and applications.

## What are the three biggest challenges or threats facing your industry in 2022?

1. Finding and developing the skills needed to cater to the national demand for energy-saving compressed air systems. Experienced and trainee management, service technicians, salespeople, system designers, warehouse and logistical service and support personnel are needed to take the industry to the next level.
2. Further developing working partnerships with our clients so they can take full advantage of the complete range of products and services that will ensure them trouble-free and cost-saving compressed air supply that exactly matches their applications.
3. Selecting and marketing the right choice of products and services that cater to the current and future needs of our customers in providing the latest, proven expertise, engineering and technologies that continue to deliver our promise of 'Engineering the Future'.

## What impacts have the pandemic lockdowns had on your industry, and how does this affect your business strategies for 2022?

Whilst the past two years have been extremely difficult in terms of workforce, production and maintenance restrictions, we have spent our time keeping our operating customers' compressed air systems running at peak efficiency and stocking up with the latest world-class machinery and system components ready for the inevitable demand to come this year and beyond. We have gone from a 'just in time' inventory model to a 'just in case' model, meaning we are well placed with excellent levels of inventory to take on the expected industry demand in 2022.

We are very optimistic of the growth in the Australian manufacturing and general industry over the coming years and have planned to lead the Australian compressed air industry in the recovery. Heavy industrial, manufacturing, automotive, mining, food, instrumental, electronics, you name it, we are ready with the products and capabilities to match the exacting needs of any application.

It will be imperative for businesses to minimise energy use whilst increasing productive output. Compressed air operators must critically assess their current system for inefficiencies and calculate input energy to determine the need for upgrades to new equipment.

## Is your company working on decarbonisation strategies or net-zero goals to mitigate the effects of climate change in 2022?

Our whole global business is about reduction of energy use for increased output for our customers.

We are also working with our global group to develop advanced power regeneration and energy solutions that convert otherwise wasted energy to usable power. We supply compressors that consume around 1500 MW of electricity from the global grid and offset this with renewable expander generation systems that produce well in excess of 1500 MW of electricity. For that reason, we are, in effect, carbon neutral.

The global Kaishan Group manufacturing divisions are already carbon neutral with stringent production recycling policies and implementation procedures.

## How is your industry preparing for artificial intelligence (AI) developments and/or advanced manufacturing?

1. By developing more highly automated functioning of industrial air compressors through variable speed drive technology that programs the compressor to provide for fluctuating demands in work schedules thereby using less energy in lower or non-usage periods.
2. Introducing advanced 2-stage compressors that allow the compression ratio to be split over two distinct rotary screw airends resulting in less slippage, less bearing loads and with intercooling, significantly higher outputs for the installed motor power. The output of a 2-stage compressor is typically around 20% higher than that of an equivalent single-stage compressor.
3. Supplying new age, PMV compressed air systems that combine the most energy-efficient combination of proven energy-saving technologies in the compressed air industry today. It's a game changer, offering unsurpassed efficiency in compressors down to 15 kW, providing models suitable for virtually any industry application. When PMVF is applied through two-stage technology models it can provide up to 50% increased efficiency over conventional fixed speed compressor types.



*For over 30 years Mark Ferguson has worked with a myriad of compressed air equipment applications across Australia. Starting in the industry as a Graduate Engineer, Mark has been involved in all aspects of compressed air including sales and marketing, design and manufacture through to business leadership.*



mat**CARE**<sup>™</sup> | *Composite*

# Safe once more.

PFAS remediation technology  
leaving water safe, land productive  
and concrete structures intact.

**CRC CARE was one of the first organisations globally to identify the PFAS problem and, since 2005, we have been working on the solution together with global scientists and industry.**

matCARE<sup>™</sup> Composite is the only remediation technology to fully and irreversibly eliminate the risk from PFAS using a modified clay sorbent. It treats 30+ PFAS contaminants plus major organic contaminants, including petroleum hydrocarbons and chlorinated hydrocarbons, in the one procedure.

Unlike granular (or powdered) activated carbon or biochar, it delivers a complete and long-term solution to PFAS – removing all PFAS from water and irreversibly locking up the PFAS in contaminated soils and concrete.

## Do it once, do it right with matCARE<sup>™</sup> Composite.

- ✓ Exhaustively researched
- ✓ Industry leading effectiveness
- ✓ Long-term
- ✓ Proven in the field
- ✓ 90% cheaper than landfill
- ✓ Treats multiple contaminants

We offer consultants and contractors training in PFAS contamination and matCARE<sup>™</sup> Composite technology and equipment, enabling them to accurately assess contamination and undertake the entire remediation process using our equipment.

matCARE<sup>™</sup> Composite provides the certainty that sites will be fully remediated as promised, leaving them safe once more.

**For site remediation,  
consultant or contractor  
training enquiries:**

[matCARE@crccare.com](mailto:matCARE@crccare.com)



# LAUREATE PROFESSOR RAVI NAIDU

CEO AND MANAGING DIRECTOR, CRC CARE PTY LTD; FOUNDING DIRECTOR,  
GLOBAL CENTRE FOR ENVIRONMENTAL REMEDIATION, UNIVERSITY OF NEWCASTLE

## What opportunities do you predict for the growth of your industry in 2022?

There is a growing understanding that chemical contamination of the environment is an existential threat on a scale as great as, if not greater than, climate change. In the wake of this, we have seen a shift by industry and governments towards a circular economy. This shift will continue such that businesses and governments will hardwire circular economy principles into the way that they operate. This evolution also offers enormous opportunities in the context of waste management and reuse, as well as prevention and management of contaminated sites.

## What are the three biggest challenges or threats facing your industry in 2022?

There are many issues that take attention and resources away from dealing with environmental contamination. The COVID pandemic is an obvious one in recent years, but also climate change, which remains the dominant environmental issue. These issues are gravely important, of course, but global pollution needs to be considered on the same level.

On a more practical level in Australia, differences in regulatory approaches across states and territories are a source of many frustrations and inefficiencies. CRC CARE has done much to harmonise assessment and remediation approaches and is continuing to do so. Examples include our development of health screening levels for petroleum hydrocarbons, which have been incorporated into national legislation and adopted by all regulators nationally, and the National Remediation Framework.

## What impacts have the pandemic lockdowns had on your industry, and how does this affect your business strategies for 2022?

Research into contaminated site management and remediation has been constrained heavily by COVID-enforced closure of research facilities (eg, laboratories). We also had a lot of difficulty accessing field sites (for both research purposes and actual remediation) — contaminated site remediation can't generally be done from a home office. In 2022, CRC CARE has strict COVID protocols in place (including a vaccination requirement) for personnel, to ensure safety and access to facilities and sites.

## How is your industry preparing for artificial intelligence (AI) developments and/or advanced manufacturing?

We are seeing a groundbreaking capacity for AI and machine learning (ML) to crunch massive datasets, automate environmental visualisation, and solve extremely complex problems with a speed and accuracy previously unimaginable. AI and ML, combined with 'big data' analytics, will drive 'precision remediation', which can deal with the complexity of contamination (particularly mixtures) and heterogeneity of sites. AI and

ML will also play a role in the design of industrial processes to minimise or eliminate waste generated in producing energy and materials (including hazardous materials).

We must develop new AI/ML-based systems to better conceptualise complex contaminated environments. This requires us to link existing and mined data approaches to new imaging platforms for subsurface and aerial geophysics, as well as to sensor data that take advantage of advanced AI/ML image correction and recognition algorithms. Ultimately this will yield a suite of new data-gathering tools that are rapid, cost-effective and require minimal ground disturbance (eg, via use of drones), while enabling more realistic virtual simulations of contaminated environments.

I can foresee several exciting developments in the waste sector. System analysis software models will use AI to accurately predict the outcomes of interventions or changes in the international environment. An AI-enabled database and framework for waste classification can provide a national waste archive that will define hazards in the material flow and identify viable pathways from waste to resources within individual sectors, as well as on a national scale.

Given that we will need to manage legacy sites well into the future, we also need to develop smart landfill management that employs AI-based digital twin systems (real-time virtual representations of a physical object or process) that optimise reuse, recycling and recovery from landfill, as well as help us avoid leaching of contaminants and other environmental impacts.



*Laureate Professor Ravi Naidu is a global leader in the remediation of contaminated soil, water and air, and the potential impacts of contaminants on environmental and human health. He has made major contributions to our understanding of bioavailability of contaminants and has played a major role in developing the now widely accepted 'risk-based'*

*approach to managing contaminated sites, which makes clean-up far more feasible and effective, saving industry many millions of dollars annually.*

# V-CONE FOR LNG

## Safety and quality benefits for cryogenic processes

The V-Cone flowmeter is often implemented in upstream, midstream, and even downstream oil and gas processes to measure a variety of flow media in various states and at various temperatures. The V-Cone's options for customisation are among the many factors that prompt users to choose this meter for such diverse and varied applications. Additionally, it's often the quality measures behind McCrometer's engineering and manufacturing teams that ultimately get the V-Cone specified into projects such as liquefied natural gas (LNG) and other cryogenic applications.

## LNG cryogenic applications

In the LNG process, gas is extracted from the earth, liquefied, shipped off, received by regassification plants to be reconstituted, and finally sent to the consumer. Liquefying the natural gas also reduces its volume, creating a cheaper storage and transport process, as it allows operators to reduce the gas volume by up to 600:1. Furthermore, in their gaseous state, hydrocarbons are volatile, and cryogenic liquefaction of such a hazardous material ultimately reduces the risk factor, as at below  $-161^{\circ}\text{C}$  LNG is non-flammable.

Many major LNG projects that have implemented liquefaction processes have used V-Cones for flow measurement. This process, among others, prioritises plant performance and economic efficiency. Liquefaction processes are insulated, complex systems that require metering solutions that are durable and consistent. As one of many variables in that system, the V-Cone is relied upon for its minimal-to-no maintenance needed and more than 25 year life expectancy.

## Non-LNG cryogenic applications

Cryogenic applications also exist outside the LNG market — in fact, McCrometer has provided V-Cones for very specialised and unique cryogenic projects since entering the market in 1985. The V-Cone was selected to measure cryogenic coolant for detectors

on a satellite in outer space, due to the meter's ability to measure flow media extremely close to absolute zero. The V-Cone's lifespan and durability were extremely beneficial as well — since maintenance cannot be carried out on a satellite.

## The V-Cone as an emergency shutdown system instrument

Other cryogenic applications, such as gas compressor discharge flow, rely on the V-Cone for its customisation flexibility. In addition to the V-Cone's range of standard and exotic materials for manufacturing, multiple taps can be engineered into the final device as well. Beyond the normal

process control taps, additional taps for checks and balances add a level of redundancy to bolster an emergency shutdown system (ESD). The V-Cone can be customised with multiple taps as a part of a Safety Instrumented System (SIS) to provide measurement redundancy to meet the required Safety Integrity Level (SIL). For cryogenic processes, V-Cone taps can be manufactured with different standoff heights to accommodate thermal and acoustic insulation.

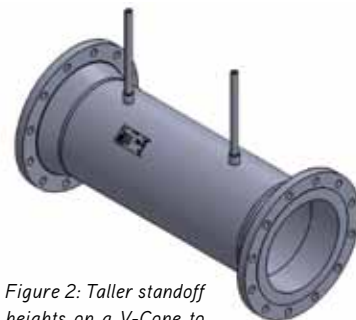

Figure 2: Taller standoff heights on a V-Cone to accommodate insulation.

## Additional V-Cone specifications for cryogenic applications

Other popular specifications for these applications include 304L stainless-steel construction due to the characteristic low temperature of cryogenic flow media. Plenty of other materials are available such as nickel-based alloys and even zirconium if required. McCrometer's engineers work on cryogenic projects often requesting low temperatures of  $-195^{\circ}\text{C}$  prompting McCrometer to perform more stringent quality checks and non-destructive testing (NDT) related specifically to temperature.

Ensuring the integrity of the welds at extremely low temperatures is critical. V-Cones for cryogenic processes are manufactured with different weld procedures to accommodate cryogenic flow media and avoid brittle fracture. NDTs are often performed on the raw material as well as the manufactured flowmeter, and may include impact testing, radiography testing, and penetrant testing, often chosen to detect fatigue cracks. All of these NDTs are meant to verify the sustainability of the welds and authenticate that in-house best practices were followed.

## Unique project? No problem

Each cryogenic flow project will face different and unique specifications and environmental factors, and each end-user will have their own project goals that McCrometer can help them achieve. Custom V-Cones are manufactured to the specifications laid out by the customer or their engineering firm. McCrometer encourages users to communicate with its engineers early on in their design process; each end-user is an expert in their project, and McCrometer's engineers are experts in flow measurement. McCrometer prioritises collaboration customers and channel partners on their challenging flow projects to help develop and manufacture lasting metering solutions.

**AMS**

**AMS Instrumentation & Calibration Pty Ltd**  
[www.ams-ic.com.au](http://www.ams-ic.com.au)



Figure 1: A V-Cone customised with multiple taps.



# Beamex MC6-T

## New revolutionary temperature calibrator



**AMS**

The Beamex MC6-T is an extremely versatile portable automated temperature calibration system. It combines a state-of-the-art temperature dry-block with Beamex MC6 multifunction process calibrator and communicator technology.

With the ability to generate temperature as well as measure and simulate temperature and electrical signals, it offers a really unique combination of functionality. In addition to temperature calibration abilities, the MC6-T also offers electrical and pressure calibration capability, all in one device.

It offers versatility, that no other temperature calibrator can match.

**AMS INSTRUMENTATION &  
CALIBRATION PTY LTD**  
Unit 20, 51 Kalman drive  
Boronia VIC 3155  
AUSTRALIA

Phone: +61-3-9017 8225  
Fax: +61-3-9729 9604  
E-mail: sales@ams-ic.com.au  
Internet: www.ams-ic.com.au

# SMART BUILDING SHOWCASE:

## NEW JLL APAC HEADQUARTERS DELIVERS HIGH EMPLOYEE SATISFACTION

**B**uilding owners and operators have been facing an exceptional number of economic and operational challenges, maybe even the greatest of their careers. While this has put many organisations under stress, it has also been an opportunity to reassess the characteristics of buildings that can affect occupant wellbeing and productivity, as well as operational performance.

The most visionary of businesses are taking a holistic approach, fully embracing the many benefits of smart building technology to move forward more quickly and successfully. As noted by Darren Battle, JLL Asia-Pacific Head of Corporate Real Estate and Workplace, "For businesses to recover fully, a smarter approach to infrastructure management is required."

Global property services company JLL took their own advice when setting the requirements for their new Asia-Pacific headquarters in Singapore. The building is the company's first smart office pilot, acting as a model for the 'Future of Workplace'. Battle explained, "At JLL we try to embrace the human side of business. At our APAC headquarters, we put people-centricity at the heart of its design. We believe that delivering the best human experience in the office space is absolutely key to our operational excellence."

The challenge for JLL was to consolidate four offices from across Singapore into a state-of-the-art space with the best possible human experience. It needed to be a relevant, engaging work environment for a new generation of the workforce. Balanced against being people-centric, the building also needed to be hyper-efficient and sustainable. Such a place would require an intelligent infrastructure.

### A smart choice of smart building technology and services

Core to enabling the ambitious goals of the project was the right choice of smart building technology. JLL found this in Schneider Electric's EcoStruxure Building platform. The key to designing and delivering the solution was the support of Automated Lifestyle, a Schneider Electric Light and Room Control EcoXpert Partner. Esther Wong, Director at Automated Lifestyle, said, "A smart office starts with a smart system designed to help measure and manage energy usage and wellness conditions. We worked with Schneider Electric at every step of the way to bring JLL a complete smart office solution."

The complete and integrated building solution includes over 150 IoT-enabled sensors to monitor space utilisation, people movement and air quality. Throughout the electrical distribution system, energy monitoring includes the use of wireless PowerTag energy meters. All room environmental and lighting conditions are managed using the KNX Lighting Control System and SE 8000 Room Controllers that provide control over lighting, blinds and kinetic sculptures. Audiovisual systems are also integrated for convenient control.



At the heart of the solution are advanced monitoring, control, and analytic applications and services. Building management tasks are automated by EcoStruxure Building Operation application and networked automation servers. The application includes an Energy Expert module that helps the facility team track energy use, meet conservation objectives and detect, diagnose and respond quickly to any power-related issues. Finally, EcoStruxure Building Advisor connects JLL to a team of experts that proactively monitor and maintain building performance, while helping optimise maintenance and maximise asset value.

### Where technology and human experience come together

The result of a strong vision driving the right design choices has resulted in a Grade A office that sets a new benchmark for the





©stock.adobe.com/au/BullRun

workplace environment. The new flagship smart office leverages big data and AI to greatly lower operating costs, improve productivity and achieve staff satisfaction.

Thermal comfort and wellbeing are being carefully managed, while employees enjoy greater engagement and a seamless user experience. For example, with building automation, users never have to touch a switch. And best-in-class, customised spaces cater to different working styles and needs. Battle said, “A study on our employee satisfaction shows positive human experience scores on factors such as health and safety provisions, air quality, light quality and temperature.”

With a single building energy management and environmental monitoring platform, JLL is now empowered to make better decisions and take advantage of condition-based maintenance. “The modular, futureproof designs in Schneider Electric’s implementations also

ensures hyper-efficiency contributing to an overall 30% reduction in energy use and operational costs.”

The new APAC headquarters has helped bring to life the JLL approach to workplace experience, providing its staff with a place to collaborate, learn, thrive and grow. It’s delivering the best occupant experience and operational excellence, while showcasing technology that will enable them to better serve their clients’ needs. Darren Battle articulated it this way: “No matter the challenges ahead, we believe that technology can give us the foresight to achieve greater ambitions.”

*To learn more about creating your sustainable and efficient Building of the Future, visit [se.com/au/buildings-of-the-future](http://se.com/au/buildings-of-the-future).*

**Schneider Electric**  
[www.se.com/au](http://www.se.com/au)

# Tired of hearing a 3 phase RCBO is going to take up 4 or 5 poles? **NOT ANYMORE**

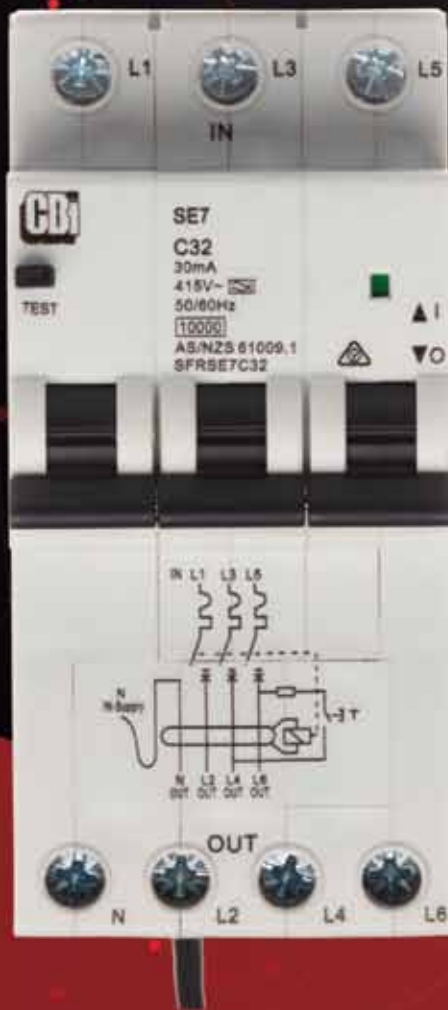

- » 10kA
- » 6-63A
- » C and D Curve
- » 54mm Wide
- » Approved to AS/NZS 61009.1

**SE4 or SE7 pick your switching direction, both DIN mount**



# Battery Storage Isolation Made Easy

QSBS250  
QSBS160

Conforms to  
AS/NZS 5139.2019

## IP67

An easy to install,  
cost effective  
alternative to the  
fuse RAT TRAP

QSBS100 QSBS125



Enclosures are fitted with a  
condensation release valve

» IP67 enclosure » Hydraulic Magnetic Breakers rated -40°C to 85°C » Lockable in the OFF position



## PROCESS CONTROL LOOP FOR WATER AND WASTEWATER TREATMENT

GF Piping Systems' complete solutions of valves, actuators, sensors, displays and controllers are designed to have an integral role for water conservation in the water and wastewater treatment industry. They can be used to increase productivity around the water cycle by raising efficiency and lowering overall costs and use of resources.

Depending on the application area, there are different challenges in water treatment processes, ranging from guaranteeing high water qualities and providing reliable measurements to assuring stringent regulations. GF Piping Systems has a wide range of process automation solutions suitable for water and wastewater treatment.

Available with a wide choice of material, the solutions have a modular set-up which allows flexible combinations. The company can provide a solution for almost all chemical resistance needs. They are also globally suitable due to a large variety of connection standards.

The measurement offer covers flow, pH, conductivity, level, temperature and various water quality parameters. Corresponding to the piping systems, most sensors are available in plastic and are therefore highly resistant to chemicals. Plug-and-play measurement products are self-explanatory, easy to maintain and offered with suitable installation fittings.

All measurement parameters can be connected with only one transmitter. Additional functionalities like batch control or communication technologies can be added anytime. The system's control products are simple to operate, have intuitive menu structures and can be upgraded in modules.

**GF Piping Systems**  
[www.gfps.com/au](http://www.gfps.com/au)

## LASER DISTANCE SENSOR

The Acuity AS2100 is a highly accurate laser distance sensor designed to work well outdoors, in bright light and on difficult targets such as dark, hot and textured surfaces. It is designed to take accurate measurements ( $\pm 1$  mm) from distances up to 500 m with a measurement frequency of up to 250 Hz.

The AS2100 distance sensor with a Class 2 red visible laser diode can measure natural targets up to 100 m with the spot size from 4 mm to about 50 mm and reflective targets up to 500 m. It can communicate using RS-232, RS-422 or RS-485 serial protocols by adjusting a single parameter. The AS2100 also comes with standard, 4–20 mA current loop output and a built-in USB connection option for easy testing and troubleshooting.

The Acuity AS2100 laser distance sensor has a wide range of applications. Metal production applications include steel and aluminium production, for controlling fill level for steel and iron, cut-to-length applications and dimensional measurements of hot materials.

Materials handling applications include crane, trolley and lift positioning and ASRS/AGV applications. AS2100 sensors also find application in fill level measurement applications, including silo level measurements.

Process control applications include cut-to-length measurements (steel and timber industries), diameter and width measurements of rolls (paper and steel) and length/width positioning measurements for sorting applications.



**Slentech Pty Ltd**  
[www.slentech.com.au](http://www.slentech.com.au)

## POWER CONNECTORS



The ILME combined CXC series of power connectors offer power and auxiliary contacts, featuring a crimp connection.

Suitable for wind energy applications, automation and installations requiring a power connector, the inserts offer increased safety and reliability, vibration resistance and a good current-density ratio, optimising the mounting space.

Choose between the two available versions: CXC 4/2 with 4 poles 80 A, 830 V + 2 poles 16 A, 400 V; or CXC 4/8 with 4 poles 80 A, 400 V + 8 poles 16 A, 230/400 V.

The series is fully compatible and interchangeable with the existing screw connection CX 4/2 and CX 4/8 inserts, and is used with CX7 silver-plated contacts for main poles, with a nominal current up to 80 A (from 6 mm<sup>2</sup>/AWG 10 to 25 mm<sup>2</sup>/AWG 4-3); and CC silver plated 16 A contacts for auxiliary poles (from 0.14–0.37 mm<sup>2</sup>/AWG 26–22 to 4 mm<sup>2</sup>/AWG 12).

**Treotham Automation Pty Ltd**  
[www.treotham.com.au](http://www.treotham.com.au)



# Reliable Security in Data Center



## THE TRUE POWER OF AN INTELLIGENT PDU

In today's world, cyberattacks, data breaches, and identity theft are all too common. Our solutions help you to prevent and combat these with extended functionality to protect your most valuable resource – data.

With award-winning solutions from Legrand, Minkels, Raritan, Server Technology and Starline you benefit from optimal uptime of mission-critical data center operations.

- **Most Reliable**
- **Easiest to Use**
- **Future Proof**



Scan to find out more



DATA CENTER  
SOLUTIONS





## Shopping centre-based EV fast-charging network underway



A strategic partnership has been forged to deliver electric vehicle (EV) fast-charging stations in shopping centre car parks.

Vicinity Centres and ENGIE have formed the partnership as part of the Australian Renewable Energy Agency's (ARENA) Future Fuels fund.

It will see ENGIE leverage the strategic locations of Vicinity's national shopping centre portfolio to deliver one of the most significant and far-reaching electric vehicle charging infrastructures in Australia.

With potential installation at up to 30 centres across Vicinity's national portfolio, the fast-charging, DC chargers will draw on renewable energy to deliver sustainable fast-charging options for users across the country, capable of charging up to 80% battery capacity in 30 minutes.

Vicinity Chief Innovation and Information Officer Justin Mills said the program represented Vicinity's long-term strategy to extract additional value from its asset portfolio by leveraging new and emerging

technology, while offering customers a more convenient and accessible way to charge their vehicles.

"With 66% of the Australian population living within a 30-minute drive of our centres, the rollout out of electric vehicle charging in our car parks will greatly expand the charging infrastructure, paving the way for greater electric vehicle ownership in Australia," Mills said.

ENGIE ANZ Director of Transport and Green Mobility Greg Schumann said ENGIE's partnership with Vicinity was an important step in accelerating Australia's transition to mass electric vehicle adoption.

"ENGIE is taking a strategic approach to EV charging, working with partners who can help us deliver charging stations that are convenient, safe and secure for customers. The collaboration with Vicinity is completely aligned with this approach and we're excited to be working with them on this project."

While delivering additional value and convenience for customers, the fast charger network will also play an important role in progressing Vicinity's decarbonisation focus, which will drive sustainable operations and deliver net zero emissions by 2030.

The first electric vehicle fast chargers will be installed in the coming months, with the remainder planned over the following two years.

Electric vehicles are expected to account for more than 50% of all vehicles sold in Australia by 2030. Currently, EV sales comprise 0.78% of the new car market (compared to a global average of 4.2%) in Australia.

## Cloud-based tool for power grid connections

A cloud-based connections simulation tool for new grid connections to Australia's electricity networks has received funding from ARENA.

The Australian Renewable Energy Agency (ARENA) announced \$2.23 million in funding to the Australian Energy Market Operator (AEMO) to develop the technology.

The \$12.95 million project will be the first step of a staged approach for the delivery of AEMO's Australian Energy Simulation Centre, which was investigated through an ARENA-funded feasibility study in 2019. The connections simulation tool is a critical foundational operating platform to achieve AEMO's overall objective to efficiently manage a large number of grid connection applications from renewable energy developers.

AEMO has identified the connections simulation tool as a critical solution to assist project developers to more efficiently prepare their applications for projects, such as new solar or wind farms, and reduce the time to connect them to the National Electricity Market (NEM).

AEMO is developing the connections simulation tool to allow project developers and their partners and electricity networks to rapidly test and



refine their renewable energy plant and project configurations using the same detailed wide-area power system simulations as used within AEMO, while preserving the confidentiality of the model data.

ARENA CEO Darren Miller said the development of the connections simulation tool would help to integrate and fast-track renewable energy into the energy system.

"Australia's energy system is evolving rapidly with most of the growth in generation coming from rooftop solar and large-scale solar and wind.

"The proposed connections simulation tool will assist large-scale developers by providing a detailed source of energy data and modelling that incorporates our electricity systems, thereby allowing them to accelerate their development process and manage potential risk before going through the formal grid connection process."

Testing will soon commence with industry participants on a working prototype, followed by a staged rollout of the connection simulation tool. The first major release is planned for the end of 2021. AEMO will work collaboratively with industry and trial users, and incorporate stakeholder feedback at each stage.



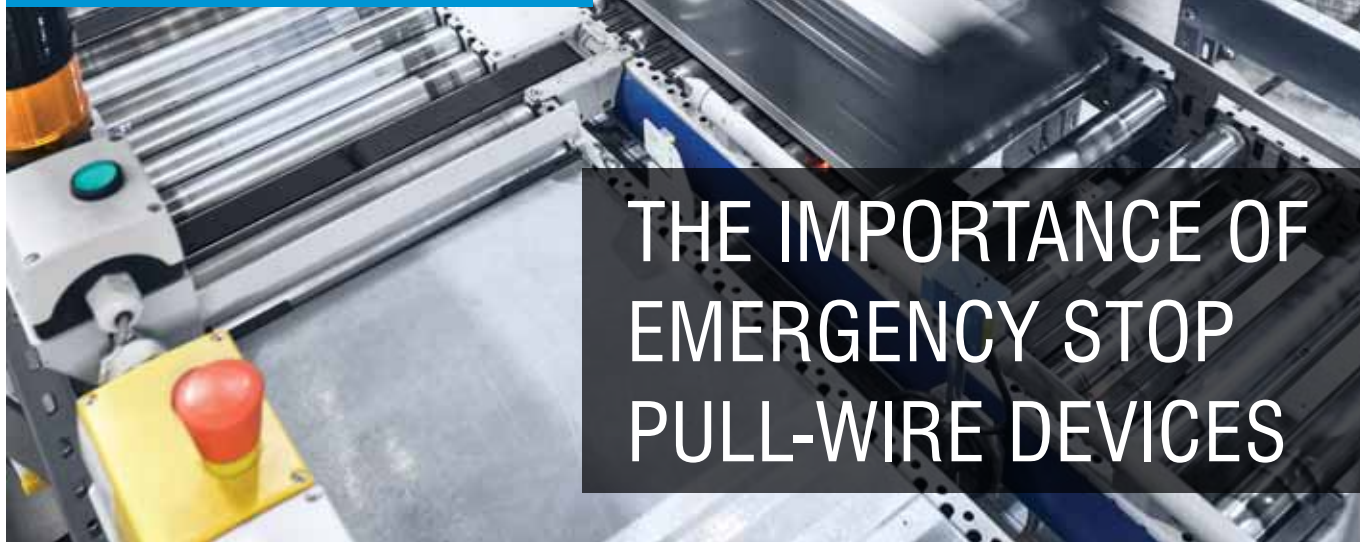

# THE IMPORTANCE OF EMERGENCY STOP PULL-WIRE DEVICES

**W**hen it comes to emergency stop devices there is no doubt that the red mushroom-head push button is the most common — they seem to be everywhere. The second most common emergency stop device is the pull wire, and like the light curtain in safeguarding devices, the pull wire is probably the most misapplied emergency stop device.

Emergency cable pull switches are designed to provide continuous emergency stop control along exposed areas of machinery and conveyors that present hazards to operators or maintenance personnel. As such, they can fulfill the requirements of having a means of an emergency shutdown at every area where a work-related task is being performed. Unlike isolated E-Stop pushbuttons, emergency cable-pull systems can be actuated at any point along the 'trip wire'.

Emergency stop pull wires are most often used where there are long stretches of machinery between normal operator stations. As an example, pull-wire emergency stop devices are commonly used on conveyors and other long machines. They can be challenging to install correctly with cable tension and support being extremely important.

Bear in mind that emergency stop systems are complementary protective measures. Complementary protective measures are backup devices to the primary safeguards, and as such they do not provide guarding to protect a person from being hit or entangled and dragged by material on the belt.

The basic idea of an emergency stop pull wire is to provide a person with a way to stop the equipment motion from any place along its length. This same idea is sometimes used when a worker could be present at many points along a piece of machinery, with no explicit workstation defined. Once the trip wire is tensioned, the switch will initiate an emergency shutdown if an operator falls into, is pulled into, or pulls on the trip wire, and will also fail to safe if the cable is cut or goes slack.

Pull-wire systems are made up of multiple components including the switch, anchor points, the cable or rope, cable guides (such as pulleys or eye-bolts), and a tensioning device. Which components are required will be determined by the application. Since the cable is flexible, it can be made to turn corners so that it can follow the work area — which also means a single system can be installed over a large distance.

As for the pull-wire switch itself, they are designed so that the switch will activate if the cable is pulled, breaks or is cut. It will also have an indicator to show that the switch has been tripped



and there must also be a way to reset the tripped connection. Switches like Schmersal's ZQ 900-02N come with a built-in push button as a secondary means to trip the switch, in addition to wire pull and breakage protection, position indicator, external watertight collar, and three cable entries.

As you can see, there are many important details to the correct installation of an emergency stop pull-wire switch. These details need to be looked after during design and maintenance, and as with any other safety device, there are many ways to do the job poorly. Cable tension, support and guidance are critical to correct operation.

Pull-wire systems are made up of multiple components including the switch, anchor points, the cable or rope, cable guides (such as pulleys or eye-bolts), and a tensioning device. Which components are required will be determined by the application. Since the cable is flexible, it can be made to turn corners so that it can follow the work area — which also means a single system can be installed over a large distance.

As for the pull-wire switch itself, they are designed so that the switch will activate if the cable is pulled, breaks or is cut. It will also have an indicator to show that the switch has been tripped and there must also be a way to reset the tripped connection. Switches like Schmersal's ZQ 900-02N come with a built-in push button as a secondary means to trip the switch, in addition to wire pull and breakage protection, position indicator, external watertight collar, and three cable entries.

As you can see, there are many important details to the correct installation of an emergency stop pull-wire switch. These details need to be looked after during design and maintenance, and as with any other safety device, there are many ways to do the job poorly. Cable tension, support and guidance are critical to correct operation.

With some care and attention to detail, users can install a system like this correctly without too much difficulty. For more information on what pull-wire switch would be best suited for your organisation, or information on machine safety or specialist training, contact Control Logic on 1800 557 705 or email [sales@controllogic.com.au](mailto:sales@controllogic.com.au).

**Control Logic Pty Ltd**  
[www.controllogic.com.au](http://www.controllogic.com.au)





# Environmentally friendly manufacture of battery electrodes

Conventional processes for manufacturing battery electrodes involve mostly toxic solvents and require much space and energy. This is not the case with DRYtraec — a new dry-coating process developed by the Fraunhofer Institute for Material and Beam Technology IWS. The technology is environmentally friendly and cost-effective and can be used on a large scale, giving it the potential to revolutionise the manufacturing of battery electrodes.

It is clear that society's overall energy demand is continuously increasing. The fast-growing electromobility sector is therefore looking for new ways to reduce the energy required to manufacture batteries and thus to design them to be as cost-effective and environmentally friendly as possible. DRYtraec is a promising solution developed by an interdisciplinary research team at Fraunhofer IWS in Dresden that focuses on the production of the battery electrodes.

A key component of any battery, electrodes normally consist of a metal foil with a thin coating. This coating contains the active components that are responsible for storing energy.

"The conventional coating process uses a wet chemical method that applies what is known as a slurry," said Dr Benjamin Schumm, Group Manager for Chemical Coating Technologies at Fraunhofer IWS. "The active material, conductive carbon and binders are dispersed in a solvent to make a kind of paste, which is initially applied to the metal foil to form a wet coating. Extremely large machines with very long drying tracks are needed to ensure that the solvent will evaporate afterward. With DRYtraec, we can design this process more efficiently."

The new coating process essentially uses similar raw materials as in the slurry process. However, the dry coating technology developed at Fraunhofer IWS works without solvents, instead using a special binder. Together, the materials form a dry mixture that is fed into a calender gap — a gap between two rollers rotating in opposite directions. The crucial detail is that one of the rollers must be turning faster than the other. This induces a shear force, which ensures that the binder forms thread-like networks known as fibrils.



"Imagine it as a spider's web that mechanically embeds the particles," Schumm said.

The pressure and motion form a fine film on the faster-rotating roller. This film is then transferred in a second calender gap onto a current collector foil. This allows both sides to be coated simultaneously without significant additional work. In the final step, the resulting coil is cut to the required size and the individual parts are stacked as appropriate in order to produce the finished battery cell.

DRYtraec has clear ecological and economic advantages over existing battery electrode coating processes. Removing toxic solvents and long, energy-intensive drying machines from the process benefits the environment. The new process also accelerates production and requires only one-third of the equipment space of a conventional solution, saving further costs.

In Schumm's view, the success of the DRYtraec process comes primarily from the diversity of expertise in the research team at Fraunhofer IWS. Colleagues with a background in chemistry worked on the optimum powder mixture, but experts in manufacturing engineering, for example, developed equipment that prevents the dry film from ever being self-supporting, ensuring that it remains stable.

The first prototype DRYtraec systems were commissioned as part of the DryProTex funding project. This project demonstrated that it is possible to manufacture electrodes continuously, regardless of the type of battery.

"The range of possible uses for the technology is not limited to a particular cell chemistry," Schumm pointed out. "It could equally be used on lithium-ion cells as on lithium-sulfur or sodium-ion cells. We are even looking at solid-state batteries. These will be increasingly important in the future, where the materials cannot tolerate wet chemical processing. Thus, DRYtraec allows us to offer a very promising solution to this problem."

The industry is showing a lot of interest in the process. Discussions are currently underway with several automobile and cell manufacturers to plan the construction of a number of pilot systems. Beyond manufacturing electrodes with DRYtraec, the re-searchers at Fraunhofer IWS are engaged in many other research projects to examine the entire battery cell development process chain. By doing so, they are playing a key role in shaping the future of the battery.

**Fraunhofer Institute for Material and Beam Technology IWS**  
[www.iws.fraunhofer.de/en.html](http://www.iws.fraunhofer.de/en.html)



# WE MAKE UNIQUE SOLUTIONS HAPPEN

MSS Data Solutions equips businesses with fibre optic design and innovation communications cabling to unleash their potential. Providing end-to-end solutions for the needs of any fibre optic and communications project in the enterprise, industrial and telecommunications industries.

We partner with our customers to deliver personalised strategies for entire projects – from invention, design and manufacture to transmission, distribution and ongoing support.

## FIBRE ENCLOSURES & COPPER SOLUTIONS CATALOGUES NOW AVAILABLE FOR DOWNLOAD!

→ Download your catalogues from [mssdatasolutions.com.au/resources](https://mssdatasolutions.com.au/resources) or scan the QR code below

SCAN ME!



## HYGIENIC CONNECTOR INTERFACE

The Han F+B range of connectors has been designed for the requirements of the food industry. Hygiene and safety are particularly important in food processing. Machines and equipment must be designed so that they are easy to clean, and dirt pockets must be avoided.

Smooth surfaces make it harder for bacteria to accumulate. The hoods, housings and seals are robust and protect the internal contacts against hose water and aggressive cleaning agents, and are certified by Ecolab and have FDA 21 approvals. The water jet from high-pressure cleaners cannot penetrate the hoods/housings when closed.

Other features and benefits include an easy-to-clean design especially for the spray zone, and secure connections, even with daily cleaning.

**HARTING Pty Ltd**

[www.harting.com.au](http://www.harting.com.au)



## CONTROLLER FOR AUTOMATION TASKS

The Siemens SIMATIC S7-1200 controllers are a good choice when it comes to flexibly and efficiently performing automation tasks in the lower to medium performance range. They feature a comprehensive range of technological functions and integrated communication as well as a compact and space-saving design.

The controller is designed as a compact CPU, which means that IOs are already integrated. Yet the S7-1200 station can be equipped with additional IO modules to enlarge the capabilities of the PLC and make it suitable for a range of Australian industry applications.

Fail-safe CPUs can be selected when safety is required in the product offering.

Because of these features, the S7-1200 offers some of the most flexible possibilities with enhanced cross-platform data transfer with other controllers and higher-level or cloud-based systems. The applications are numerous, ranging from industrial use to agriculture and infrastructure projects.

The seamless integration of the SIMATIC controllers into the common engineering framework TIA Portal provides consistent data management, the smart library concept and a uniform operating philosophy. This makes it easy to use for system-spanning functions.

Efficient error analysis and fast error localisation with the new uniform display concept shortens commissioning times and minimises production downtimes. The controller provides users with diagnostic functionality already integrated in the system without additional programming work.

Secure communication, know-how protection, copy protection and access protection prevent manipulation, opening and duplication of blocks by unauthorised persons, thus protects the user's algorithm or process.

The controllers are suitable for compact automation solutions with integrated IOs, communication and technology functions for automation tasks in the low to medium performance range. APS Industrial is the national distribution partner for Siemens.

**APS Industrial**

[www.apsindustrial.com.au](http://www.apsindustrial.com.au)

## RJ45 INDUSTRIAL PATCH CABLES

The Phoenix Contact range now includes updated RJ45 patch cables for industrial applications.

The RJ45 INDUSTRIAL patch cable series enables data speeds of up to 10 Gbps in accordance with Cat5 and Cat6A and is particularly suitable for industrial Ethernet and Profinet environments.

The connectors with a uniform look and feel feature high-quality overmoulding and a protected

locking clip to help ensure robustness. The patch cables with increased vibration resistance are suitable for industrial applications. Up to five different cable outlet directions and a broad cable portfolio including versions for drag chain and robot applications provide a versatile range of applications. All cables come with CE, cULus and EAC approvals.

**Phoenix Contact Pty Ltd**

[www.phoenixcontact.com.au](http://www.phoenixcontact.com.au)





Find out how you can

# EXPERIENCE BETTER

IPD is an Australian owned and operated business that has been servicing the electrical industry for over 60 years. We offer a wide range of products, custom solutions, and tailored services to suit any application.



**NATIONAL**  
customer service



**BEST IN CLASS**  
logistics offer



**CUSTOM**  
design assemblies



**DRAFTING**  
services



**PRE AND POST**  
technical support



**DESIGN**  
assistance

## PRODUCT RANGE



Power Distribution



Power Monitoring



Photovoltaic



Industrial Control



Installation & Accessories

Contact or visit IPD for more information:

Tel: 1300 556 601 | Email: [customerservice@ipd.com.au](mailto:customerservice@ipd.com.au)

[www.ipd.com.au](http://www.ipd.com.au)





# The ‘Tecpro Foam Busters’ help Sydney Water

Sydney Water operates 16 wastewater treatment plants. Between them, they collect over 1.3 billion litres of wastewater from homes and businesses across Sydney, the Illawarra and the Blue Mountains. This wastewater is treated before re-use or discharge into rivers and oceans following strict protocols and monitoring.

## The challenge

The Warriewood wastewater plant had a daily problem with foam. In fact, there were times when the plant’s operators were knee deep in foam. Not only was this a safety concern for workers, the foam left a residue which could impact the electrical equipment used to operate the plant.

The foam was generated during the treatment process when a treating chemical was added to the agitated liquid.

Spray nozzles had been installed previously but they were ineffectual as they were prone to blocking and required lots of maintenance.

## The solution

Sydney Water contacted Tecpro Australia in search of a turnkey solution. The Tecpro team recommended and installed a ring of special blockage-



Foam control pit sprays.

resistant nozzles inside the treatment pit. For the Sydney Water environment, these nozzles spray coarse droplets which break up the foam by bursting the bubbles during the agitation process. This prevents foam growth and build-up.

In the plant room gantry, another set of blockage-resistant spray nozzles was installed directly above the pit to prevent foaming incidents in extreme conditions (such as after heavy rain where process volumes increase).

Tecpro managed the whole process — from designing the system to implementation. For Sydney Water, it was a turnkey solution.

## The outcome

Two months after installing the new foam suppression system, Tecpro Australia contacted Katie Shield, a Production Officer for Sydney Water, to see how things were going at the

Warriewood plant. Katie’s response was:

“It has been working brilliantly! No complaints from our team at all. In fact, we haven’t had a foaming incident since!”

**Tecpro Australia**  
[www.tecpro.com.au](http://www.tecpro.com.au)

# Wastewater plant for Somerset, Qld

A new state-of-the-art wastewater treatment plant is now up and running in Somerset, Queensland, marking the completion of a \$45 million upgrade to vital infrastructure in the region.

The upgrade is Urban Utilities’ largest project in Somerset to date, and also included the laying of 8 km of new pipes and the construction of two new wastewater pump stations.

The new plant will be capable of treating 1.5 megalitres of wastewater every day from Lowood and Fernvale.

Urban Utilities Resource Recovery General Manager Peter Donaghy said the upgrade would ensure the region was well and truly prepared for growth.



Peter Donaghy from Urban Utilities with Somerset Regional Council Mayor Graeme Lehmann at the new wastewater plant.

“As more people choose to call beautiful Somerset home, it’s important we lay down the foundations for the future,” he said.

“The treatment plant has doubled the capacity of the local wastewater network, ensuring the region has the infrastructure it needs for many years to come.

“Equipped with the latest membrane technology wastewater treatment, the plant will also deliver environmental benefits for local waterways.”

Donaghy said the previous Fernvale and Lowood treatment plants were significantly impacted by the 2011 floods and the location of the new plant provided important flood resilience.

Somerset Regional Council Mayor Graeme Lehmann welcomed the completion of the upgrade.

“Somerset is one of the fastest growing regional council areas in Queensland and this significant investment by Urban Utilities will make sure we’re well prepared for growth,” he said.

“This is a great outcome for our region.”

In an additional benefit, the new wastewater treatment plant will also provide high-quality recycled water to sustainably irrigate Fernvale Sports Park.

The Drought Solutions Pipeline was funded under the Queensland Government’s Unite and Recover Community Stimulus Program part 1.

**Urban Utilities**  
[www.urbanutilities.com.au](http://www.urbanutilities.com.au)



# Robust Portable Label Printers

Industry leading contractor grade printers with extended warranty



## Epson + Panduit + Register Online = 2 Years Warranty

Panduit Mobile Label Printers are the ideal solution for labeling on the go. They offer the ultimate in flexibility with USB, Bluetooth and mobile app connectivity whilst our MP300/E Mobile Printer features **magnetic** attachments. Register online to receive an additional 12 month extended warranty on top of our standard 12 months.

**Register your Panduit Mobile Printer online to extend your Warranty to 2 years**



**REGISTER ONLINE TO EXTEND YOUR WARRANTY**

For more information:  
Phone **1 800 PANDUIT** or visit [panduit.com](http://panduit.com)

**PANDUIT**<sup>™</sup>

**EPSON**  
EXCEED YOUR VISION

PORTABLE LABEL PRINTER PARTNER

## THERMAL IMAGING CAMERA

FLIR Systems has released its latest T-Series high-performance thermal camera, the FLIR T865. Built for electrical condition and mechanical equipment inspection, the product provides  $\pm 1^\circ\text{C}$  or  $\pm 1\%$  temperature measurement accuracy, a wide temperature range between  $-40^\circ\text{C}$  and  $+120^\circ\text{C}$ , and on-camera tools for improved analysis.

The device offers professionals versatility with portable and handheld fixed mount options for inside and outside work in harsh conditions, and multiple lens options to inspect objects both near and far. The available  $6^\circ$  telephoto lens provides the required magnification for those routinely inspecting the condition of small targets at a distance, such as overhead powerlines.



A free three-month subscription to FLIR Thermal Studio Pro and FLIR Route Creator, and a one-month subscription to FLIR Research Studio, is included with purchase.

**Teledyne FLIR**  
[www.flir.com.au](http://www.flir.com.au)

## COMPRESSORS WITH PM MOTORS

Boge has now fitted some models of its C-series screw compressors with a permanent magnet motor. The C 7 PM model with a rated output of 5.5 kW for the drive motor offers free air delivery and efficiency with lower noise levels and a reduced footprint. In the 7.5 kW performance class, the C 9 PM improves on its predecessor with improved free air delivery and efficiency.

These compressors are designed to provide high free air delivery over time. Boge says the permanent magnet motor ensures that higher free air deliveries are possible despite consuming the same amount of power. This means users benefit from reduced compressor energy consumption: in the case of the C 9 PM, the savings are over 6%.

Due to their modular construction, these C-series compressors with permanent magnet motor can be combined to meet the user's requirements. For example, users can install the machine on its own or in combination with a receiver (model R), or with a dryer (model DR). All the compressors are also fully compatible with Boge's master control systems.

**Boge Compressors Ltd**  
[www.boge.net.au](http://www.boge.net.au)



## BIT HOLDER FOR IMPACT DRIVER

The Crescent VORTEX bit holder is designed to extend the life of any  $\frac{1}{4}$ " hex shank bit.

According to the company, the dual impact zone in the bit holder extends the life of bits by up to 500 times when used with an impact driver. It is designed to absorb the shock of repeated, heavy usage in impact applications while still delivering maximum torque from the impact driver. That durability makes the bit holder suitable for jobs where professionals are using impact drivers countless times each day.

The bit holder is available as a single item and is included in eight VORTEX bit sets ranging up to 55 pieces.

**Apex Tool Group**  
[www.apextoolgroup.com](http://www.apextoolgroup.com)



# PRO SERIES

## ADVANCED POWER QUALITY METERING

### with FCAS Capability



**PM335:**  
PANEL MOUNT



**EM235:**  
DIN RAIL

**REVOLUTIONARY DESIGN**

**SUPERIOR PERFORMANCE**

**INTUITIVE USER INTERFACE**

The PRO Series is SATEC's cost-effective line of power meters for advanced power monitoring applications. With waveform recording capabilities and 16GB of storage it is a powerful power quality analyzer and event recorder.

Featuring multiple protocols (IEC 61850, MODBUS, MODBUS MASTER, DNP3 and IEC 60870-5-101/104) and multiple communication ports RS485, USB, Infra Red and dual ethernet.

The ultimate solution for AC and DC power monitoring, meeting and exceeding all measurement requirements for commercial, industrial and utility applications.

ACCURACY CLASS 0.2S	DIGITAL INPUT	Modbus 101/104 DNP3 SERIAL PROTOCOL	DUAL PORT ETHERNET	WAVEFORM CAPTURE/LOGGING	IEC 61850	16GB MEMORY	ENERGY MANAGEMENT	REMOTE SETTINGS	SCADA READY	SUBSTATION AUTOMATCH	INDUSTRIAL MONITORING	RENEWABLE ENERGY
---------------------	---------------	--	--------------------	--------------------------	-----------	-------------	-------------------	-----------------	-------------	----------------------	-----------------------	------------------

Another 1st by

PHONE: (02) 4774-2959  
www.satec-global.com.au





## A concrete solution



A recycled concrete solution developed by researchers at the University of Tokyo could reduce emissions from the construction industry. Calcium carbonate concrete is made from waste concrete and carbon dioxide from the air or industrial exhaust gases. It shows promise as a future construction material, especially in places where natural resources are limited.

It is estimated that around 7% of the world's carbon dioxide emissions come from the manufacture and use of cement, the main component of concrete. And a large proportion of this 7% is due to the necessary use of calcium, which is usually obtained by burning limestone.

A new way to reduce emissions levels caused by concrete use has been proposed and proven to work by Professor Ippei Maruyama and C4S (Calcium Carbonate Circulation System for Construction) Project Manager Professor Takafumi Noguchi, both from the Department of Architecture at the University of Tokyo. They have found a way to take waste concrete and captured carbon dioxide, and combine them in a novel process into a usable form of concrete called calcium carbonate concrete.

Inspired by the way some aquatic organisms harden into fossils over time, Maruyama wondered if the same process that forms hard calcium carbonate deposits from dead organic matter could be applied to concrete. Calcium is essential for the reaction between cement and water to form concrete, and Maruyama saw this as an opportunity to investigate a less carbon-intensive way of performing the same function.

"Our concept is to acquire calcium from discarded concrete, which is otherwise going to waste," Maruyama said. "We combine this with carbon dioxide from industrial exhaust or even from the air. And we do this at much lower temperatures than those used to extract calcium from limestone at present."



*Concrete samples. Two samples of calcium carbonate concrete, one using hardened cement paste (left) and the other using silica sand. Both raw materials are common construction and demolition waste products. © 2021 Maruyama et al.*

Calcium carbonate is a stable material, so makes for a durable construction material. And the ability to recycle large quantities of material and waste is a great benefit. However, calcium carbonate concrete cannot replace typical concrete at present. It is not quite as strong as typical concrete, though for some construction projects, such as small houses, this would not be a problem. Also at present, only small blocks a few centimetres in length have been made.

"It is exciting to make progress in this area, but there are still many challenges to overcome," Noguchi said. "As well as increasing the strength and size limits of calcium carbonate concrete, it would be even better if we could further reduce the energy use of the production process. However, we hope that in the coming decades, carbon-neutral calcium carbonate concrete will become the mainstream type of concrete and will be one of the solutions to climate change."

The research paper has been published in the *Journal of Advanced Concrete Technology*.



MELBOURNE  
CONVENTION  
& EXHIBITION  
CENTRE

 **COMMS  
CONNECT**

Events for critical communications users and industry

# MELBOURNE

## 8-10 MARCH 2022

FREE  
EXPO  
ENTRY

### Featured speakers:



Shane Fitzsimmons AFSM  
Commissioner  
Resilience NSW



Lynn McDonald  
Azure Space Lead  
for Australia



Mats Henrikson  
Group Leader  
CSIRO Data61



Ed Parkinson  
CEO  
FirstNet USA



Jackie Dujmovic  
Founder and CEO  
Hover UAV



Neal Richardson  
Technical Director  
NZ Police  
NGCC Lead Agency

### What's on:

- Industry-focused case studies and technical presentations
- Panel sessions on public safety, state of the industry and satellite evolution
- Extensive exhibition and networking opportunities
- ARCIA Industry Gala Dinner on 9 March

### Half-day workshops – 8 March

- Power supply options for communications systems, including solar and battery options
- Latest initiatives and innovations in critical LMR, critical broadband 4G/5G and control centres
- Private LTE/5G – the fundamentals of technology and system design
- ACCF Public safety communications ‘town hall’ meeting

## BE INVOLVED

Contact Narelle Granger [ngranger@wfmedia.com.au](mailto:ngranger@wfmedia.com.au) for sponsorship and exhibition enquiries

#### Platinum Sponsors:



#### Gold Sponsors:



#### Silver Sponsors:



#### Media Partner:



#### Association Partners:



Visit [www.melbourne.comms-connect.com.au](http://www.melbourne.comms-connect.com.au) for more information

# HOW WASTE MANAGEMENT OPERATORS

ARE DEALING WITH NEW CHALLENGES TO OPERATE IN RESIDENTIAL AREAS AS LAND CONFLICTS ARISE

Alex Zamudio, Environmental Intelligence Advisor at Envirosuite

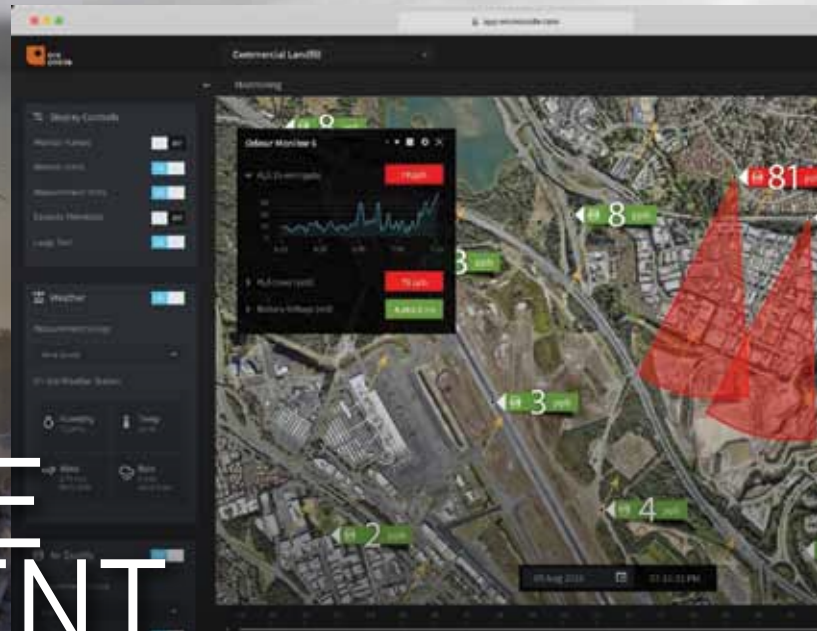

## Odour complaints arise from the community

Odour impacts livability. It's the reason for a large number of complaints made to environmental authorities and in communities, with landfills often listed as the top source.

Operators with odour issues generate hundreds of complaints a month. These complaints are often supported by a range of external data, from odour diaries and sniff tests to formal air quality monitoring systems set up by investigators.

Communities are increasingly impatient about slow and indecisive responses to odour complaints, so it is more important than ever that operators can minimise uncertainty, and reduce the time between a problem occurring and a solution being actioned.

For operators, odour management is a complex and increasingly technology-driven process. Outside factors such as meteorological conditions play a part in management approaches and need to be modelled with internal data to make abatement and control measures effective.

## New challenges in waste management as suburbia sprawls

New set of challenges driving unprecedented change in the waste management sector include:

- Residential populations are brought into closer proximity to previously isolated waste and industrial facilities.
- Landfill site operators with legacy facilities permits are under community pressure to modernise to meet quality-of-life expectations.
- External researchers are pouring pressure by using GIS, census, and satellite data to assess the suitability of locations for solid waste management.
- Communities concern more on air quality issues caused by waste management centres and industrial sites.

## How to (re)build trust within the community

As cities sprawl and communities come into closer proximity with waste sites, sustainable operations have never been more critical. Sustainable landfill operations stand on three pillars:

1. Compliance
2. Optimisation
3. Community engagement

Communities are redefining their relationship with waste management sites where odour emissions and air quality impacts due to uninformed operational decisions can lead to compliance breaches. Communities, regulators and industry need to be able to trust that one another are doing the best they can for the benefit and in the best interests of everybody. That requires an open conversation and an end to negative actions. Communities lose faith in operators that are perceived to care only about money, and not about community safety or environmental concerns.

Nowadays, residents contact landfill sites directly as they can easily find information of rankings and reviews on the internet. Communities now have a voice, an open opportunity to engage with a waste facility operator and the ability to suggest actions or influence operations, so they are more likely to accept the facility's ongoing presence. They are also less likely to lodge complaints with authorities, since they can be confident of gaining a direct audience with the operator, with a high likelihood of open dialogue and positive action or redress.

## The power of environmental intelligence in waste management

Over the past five years we've seen a significant change in the technologies available for odour detection. Only a decade ago, odour detection and management required specialist precise equipment.





Now, operators can use small, cheap sensors and low-power communications for the same purpose. Data collected from these devices can be transmitted to a central point and run through environmental intelligence platforms to identify patterns and uncover insights that can inform interventions, such as misting controls, covers, methane management and other onsite mitigation techniques.

Envirosuite provides environmental intelligence tools that enable operators to comply with permitted conditions, optimise odour mitigations and hold conversations with government agencies and communities that build and engender trust in the handling of environmental concerns. Environmental intelligence provides a 'bird's eye view' of operations, helping operators to understand what's happening and what could happen next.

Operators can calculate odour at specific locations within their site and outside its boundaries to understand any potential impact now and up to 72 hours into the future. They can also pinpoint the likely source of odour complaints to drastically shorten investigation times. These insights can be shared with local residents to help the site avoid problems, reduce costs and maintain a good reputation in the communities it serves.

### About the author:

*Alex Zamudio is Envirosuite's leading Advisor in the Eastern USA region, helping organisations in waste, wastewater and industrial operations transform their business and increase value-creation across the board through environmental intelligence. Alex has over 15 years of experience helping clients succeed through digital transformation and continues to drive Envirosuite's growth in the region by providing operators with intelligent tools that help them maintain their social licence and increase operational efficiencies.*

**Envirosuite Operations Pty Ltd**  
[www.envirosuite.com](http://www.envirosuite.com)



### SWITCHGEAR

The ABB NeoGear 4-pole switchgear offers real-time condition monitoring and predictive maintenance.

Its design eliminates hazardous exposure to live parts. The company says it uses 92% fewer busbar components than traditional switchgear and, with 90% fewer electrical joints, improves switchgear availability.

The arc ignition protected zone is designed to keep maintenance personnel safe when performing routine works and repairs, while also reducing the risk of arcs caused by

mechanical failures — one of the most serious safety risks that switchgear operators encounter.

The switchgear offers a reduced physical footprint of up to 25% compared to equivalent switchgear technologies, according to the company. Within this compact footprint, it also achieves energy efficiency of up to 20% due to reduced heat dissipation.

The 4-pole version, as well as the upcoming 690 V version, is suitable for numerous market segments and industries, including utilities, infrastructure, data centres, infrastructure and lighting. The solution offers connectivity capabilities for data analytics and data communication, making it a suitable low-voltage switchgear option for facilities working towards achieving Industry 4.0 standards.

The expanded digital capabilities include real-time condition monitoring and predictive maintenance, remote assistance, fault and solutions diagnostics, and data analytics for Industry 4.0. Furthermore, ABB Ability condition monitoring for electrical systems (CMES) is included to help users gain additional operational efficiencies.

**ABB Australia Pty Ltd**  
[www.abbaustralia.com.au](http://www.abbaustralia.com.au)



# Plastic recycling pilot for healthcare waste

NSW hospitals generate approximately 52,400 tonnes of waste a year, which costs the NSW Government at least \$16m in disposal. Now, a NSW Circular initiative has uncovered a way for NSW hospitals to improve the recycling and reuse of some single-use plastic healthcare products previously destined for landfill.

The demonstration project, conducted at St Vincent's Hospital, Sydney, enabled Orange-based company Allmould Plastics Group to recycle ampoules and needle caps into new building materials, with support of SMaRT@UNSW Sydney.

The waste was collected from selected clinical areas in the hospital, which accounted for 28% of all ampoules and 11% of all needle caps used in the hospital — in just three months, more than 80,000 pieces of clinical waste plastic was collected. If the scheme was expanded to cover all clinical use of these two items alone, this would recover nearly 2 million pieces (or 4 tonnes) of plastic a year from this one hospital.

The 205 kg of plastic collected in the trial was then recycled into products, including 1500 roller door wheels and 7400 building industry grommets and packers, which will be deployed across Australian sites.

The report, *Plastics in Healthcare: A Circular Economy Transition Plan*, found the project has scale-up potential with clear environmental and economic benefits. By recycling just 40-60% of the clinical waste



currently incinerated or landfilled, NSW hospitals could create annual savings equivalent to the cost of hiring 40 nurses. The report also found nearly 30 new additional jobs could be created in plastics recycling by turning high-quality clinical plastic into new components.

NSW Minister for Jobs, Investment, Tourism and Western Sydney, the Hon. Stuart Ayres MP said: "If every hospital in NSW undertook this program, we would be able to unlock significant savings that could be reinvested into patient care and essential services. At the same time, we would divert plastic waste from our environment and create new jobs and economic opportunities in recycling these materials."

St Vincent's Hospital CEO Associate Professor Anthony Schembri AM said the project proves that it is possible to extract value and design out of waste without compromising health or safety. "Recycling even just two

items across all clinical use can recover nearly two million pieces, or four tonnes of plastic per year, in just one of our hospitals alone. It's just the beginning."

Rodrigo Fritis-Lamora, Heart/Lung Transplant Coordinator at St Vincent's Hospital who implemented the project said: "We see enormous amounts of plastic waste going in the bin every day; it is truly disheartening. Being at the frontlines, staff have a huge desire to see more sustainable practices and we're just so happy to see our efforts resulting in real benefits to both the hospital and environment."

Scott Cantrill, Client Adviser, Allmould Plastic Group, can see the economic impacts the rollout of this project, and more of its kind, will have in regional areas such as Orange, where their business is located. "As a result of this project we are now negotiating with waste service companies and hospitals to increase our plastic feedstock and capacity. This will enable us to engage more full-time employees and support a multimillion-dollar investment in plant upgrades," Cantrill said.

Following the success of this demonstration project, NSW Circular has announced the development of new partnerships with Hunter New England and Northern Sydney Local Health Districts to divert waste from landfill, and to drive efficiencies, new jobs and investment.





# CREATING RESILIENCE, MITIGATING DISASTER



**F**rom facing a global climate crisis, to navigating a global pandemic, it's never been more important for organisations to increase their resilience in the face of disaster.

And by mitigating risks and reducing their impact, businesses around the world are realising that championing sustainable development not only saves lives (and revenue), but also helps them to achieve a competitive advantage.

Graduates of emerging postgraduate degrees like the University of Newcastle's Master of Disaster Resilience and Sustainable Development are leading this change.

The degree equips people from diverse backgrounds to understand resilience and sustainable development principles and systematically apply them to avoid disasters, operate through extreme events and emerge better placed to face the future.

It's designed for those in management positions (or those aspiring to be) whose work involves resilience-building through the mitigation of impacts arising out of extreme events — which can be as varied as natural disasters, data breaches, political instability, terror attacks or health epidemics.

Rhian Blackwell, a recent graduate from the University of Newcastle's Master of Disaster Resilience and Sustainable Development, is currently employed as an Emergency Management Coordinator with ACT Health. Throughout his career Rhian has seen and experienced extremes, from bushfires through to a global pandemic.

"Needless to say, we've had a busy 12 months.

"The program looked at prevention, mitigation strategies and how to build communities to be more resilient in the face of a hazard — and potentially avoid a disaster," Rhian said.

A major drawcard of the University of Newcastle's degree is its development in partnership with the United Nations, and its delivery through CIFAL Newcastle — a United Nations training centre with a focus on disaster resilience and sustainable development.

The result? Graduates are emerging with the best-practice knowledge and skills needed to implement the new UN Sustainable Development Goals and the Sendai framework for Disaster Risk Reduction — and make a real and lasting impact.

"It's attractive. It's one of the reasons why (students) choose the University of Newcastle to study," said graduate Aileen Mendoza.

The University of Newcastle offers its Master of Disaster Resilience and Sustainable Development full-time or part time, online or face to face. For professionals like Rhian, this flexibility made all the difference.

"The flexibility of online study — to catch up with lectures at nine o'clock at night as bedtime reading — suited my situation, and meant I could keep up with the course while still having downtime.

"The academics were as accessible to the online students as they were to the campus-based students. I spent a lot of time communicating with the program convenor," Rhian said.

Another graduate of the program, former journalist, foreign correspondent and filmmaker Ginny Stein, said the degree has expanded her career prospects in new and exhilarating ways.

"I'm working with the Forestry Department of Vanuatu under the Australian Government's Volunteers for International Development Program.

"I've been able to continue filming and editing, plus implement a social media campaign aimed at promoting forestry awareness," Ginny said.

## Career boom

Don't be surprised if you start hearing the term 'Resilience Officer' more and more. Organisations are increasingly embracing this terminology — and the intention behind it. Whether it's in local government, planning and implementing strategies for town planning, urban and rural development, community safety or service continuity in times of emergency, demand is growing.

Career opportunities are increasing in the private sector too — in business continuity, environmental protection, risk management, disaster recovery planning, emergency and crisis management and workplace health and safety functions.

To learn more about studying a Master of Disaster Resilience and Sustainable Development at the University of Newcastle visit [newcastle.edu.au/disaster-resilience](http://newcastle.edu.au/disaster-resilience).

**University of Newcastle**  
[www.newcastle.edu.au](http://www.newcastle.edu.au)



## SMART CAMERA WITH MODULAR SOFTWARE

The Wenglor weQube is a smart camera that combines a number of features into a single vision platform. With its intelligent, modular software concept, weQube can be adapted to different applications, whether for image processing, for detecting letters

and symbols or for scanning 1D/2D codes.

The weQube smart camera is based on Wenglor MultiCore technology, which combines modular software with five high-performance processors for rapid image processing without any loss of time. It offers two different image chip versions of colour and monochrome, and a teach function for easy remote maintenance and checking of the system. The 3D tracking and autofocus are designed to provide optimal object detection.

The camera has a graphic display and 12 LEDs of red light, white light or infrared light in the housing to provide illumination and prevent loss of brightness.

Communication interfaces include Ethernet, Profinet, RS-232 and an FTP server. It offers a replaceable screening grid and integrated polarisation filter, making it suitable for special applications in rough environments. It also offers six free inputs and outputs, an encoder output, a removable micro SD card, an intuitive set-up wizard and a compact IP67 housing.

The software packages are weQubeVision for standard image processing and pattern matching, weQubeDecode for scanning applications, weQubeOCR for character recognition and weQube offering all the modules in one package.

**Treotham Automation Pty Ltd**

[www.treotham.com.au](http://www.treotham.com.au)

## HIGH-VOLTAGE EV FUSES

The Eaton eMobility Bussmann EVK series of fuses are designed for high-powered electric vehicles.

According to the company, the full line of fuses require up to 33% less space than traditional fuse solutions, offer weight reduction and provide short-circuit protection for conductors.

The high-voltage fuses meet the requirements for use in the latest high-powered electrified vehicles (EVs) with ratings up to 1000 VDC and 600 A.

The fuses are designed to manage and protect the charging systems of electric commercial, passenger and high-performance vehicles such as sports cars and large sport-utility vehicles. The fuses enable more advanced EV system architectures and support vehicle acceleration and range.

The series is designed with the future in mind as battery requirements increase and technologies, such as energy dense solid-state batteries, are introduced. The fuses are available in eight different frame sizes, ranging from 15 A for auxiliary components up to 600 A for battery protection when the full application current is flowing. The fuses are designed to distribute heat away from weak spots, a key benefit for any fuse rating and especially critical for high-power fuses.

**Eaton Electrical (Australia) Pty Ltd**

[www.eaton.com](http://www.eaton.com)



## SELF-POWERED MODULE FOR AC CURRENT

ICP Australia has introduced ICP DAS's iWSN-1120X-240-RCT1000P. The iWSN series sensing module is a self-powered module for AC current, digital input and temperature measurement. It can harvest the demand electricity from CT induced current so that there is no need to supply the power line for power supply.

Employing sub-1G RF communication interface, the series can approach to real wireless deployment. The diversified IO interface, such as split-core CT, Rogowski coil, NTC thermistor and dry contact DI, provides users with more choices for various applications. Considering the maintenance and installation, the sensing module uses the DIP switch and rotary switch for configuration.

Applications include saving power, big data analysis and predictive maintenance.

The operating temperature is -20 to +50°C, and it is available in wall-mount and magnet for easy installation.

**ICP Electronics Australia Pty Ltd**

[www.icp-australia.com.au](http://www.icp-australia.com.au)



# GENOX Washing Plants. Intelligent, cost effective plastic recycling solutions for Australian industry.

## That's Applied Thinking.



Genox Washing Plants are high performance recycling systems for rigid or flexible plastics from various sources, including materials with high contamination levels. These modular systems are capable of processing general plastics including HDPE and PET bottles, PP woven bags and PE film (post-consumer or agricultural).

- High speed washing system with corresponding speed according to material type
- Under-water force-washing paddle maximises washing efficiency
- Minimises the recycling water flow rate and evaporation losses
- Mechanical and thermal drying system minimises the moisture of the end product
- System automation to ensure components actions are linked, system capacity is maximised and protected against interfering material
- Repelletising system can be fully integrated into the plant to deliver high quality, high purity pellets that are ready for immediate sale into local and global markets



To find out more, call: 03 9706 8066, Email: [sales@appliedmachinery.com.au](mailto:sales@appliedmachinery.com.au), or visit: [www.appliedmachinery.com.au](http://www.appliedmachinery.com.au)



# THREE PRODUCTS THAT KEEP INDUSTRIAL AUTOMATION HUMMING

Keeping modern industrial automation humming — from maintaining assembly lines running to managing power distribution — requires a multitude of devices for businesses of all sizes. Manufacturers continually strive to create and refine products that will enhance productivity and safety while controlling costs. Maintaining automation standards means better customer service, the lifeblood for manufacturers in a competitive environment. This means increasing and upgrading quality, flexibility, and data analysis collection in the manufacturing process and building on the productivity gains associated with automation, including robots and collaborative robots.

With so many moving parts, it's a process that seems to have no end.

Robots and cobots are significant to industrial automation's progression. The evolution of Industry 4.0 has room for humans and bots working together on the factory floor. A 2017 International Federation of Robotics' positioning paper maintains that automation and the ongoing development of robotics have a positive impact on employment, job quality, and wages.

To accomplish this progression, automation developers require a diverse array of parts — sensors providing raw data and feedback, control systems, programmable logic, connected embedded devices.

## From actuators to switchgear to position sensor

The Trinamic PD42-1-1243-IOLINK PANdrive IO-Link Actuator enables smart factories to remotely adjust an actuator's electrical characteristics to minimise factory downtime and maximise throughput. The device combines a NEMA-17 stepper motor with a controller and drive electronics. The actuator monitors 50% more configuration and performance parameters to reduce commission times and improve predictive maintenance data

quality. It might be small (2.6 times smaller than its competitors), but it incorporates motion-control technology into a plug-and-play solution.

Omron Industrial Automation J7 low-voltage switchgear is suitable for motor application solutions in every industry and conforms to space-saving control panel design's main safety standards. The push-in plus-style gear connects J7KC magnetic contactors, J7MC manual motor starters, J7KC/J7KCA industrial relays, and the J7TC thermal overload relays. The metal-enclosed switchgear is a three-phase power distribution product designed to safely, efficiently, and reliably supply power at voltages up to 1 kV and current up to 6 kA.

The Bourns HES38U-RS485 hybrid position sensor is designed for heavy-duty industrial applications requiring long cycle life and high reliability. The Bourns sensor comes in the form of a 6 mm diameter slotted shaft that provides position feedback on automated manufacturing robotics, 3D imaging, pneumatic control valves, draw wires, actuator motors, and electric linear actuators. Available in a servo-mount configuration, the sensor is durable with a rotational life of up to 5 million shaft revolutions.

## Conclusion

Industrial automation is regarded as the second step beyond mechanisation in the scope of industrialisation. For designers and developers, the human element means keeping up with a lot of diverse moving parts — from actuators to switch gear to sensors — in maintaining the hum of the industrial automation machine.



**Mouser Electronics**  
[au.mouser.com](http://au.mouser.com)



# Delivering more

The widest selection of semiconductors and electronic components in stock and ready to ship

---

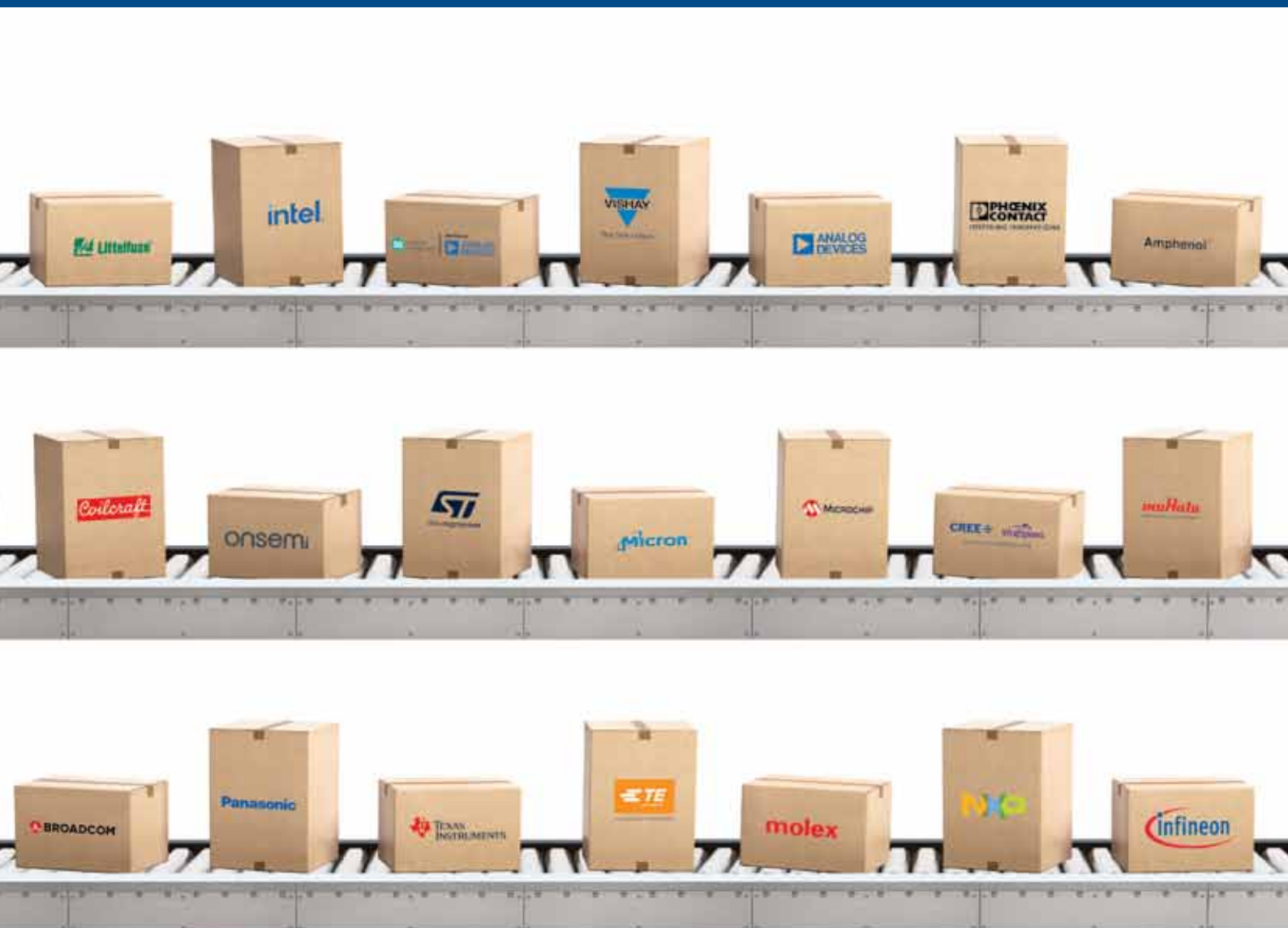

[au.mouser.com](http://au.mouser.com)



[australia@mouser.com](mailto:australia@mouser.com)



## INDUSTRIAL VACUUM SYSTEMS

EXAIR manufactures industrial duty vacuums for chip removal, liquid transfer and cleaning. All systems use compressed air powered vacuum generators that have no moving parts, no impellers to clog and no motors to wear out, assuring maintenance-free operation. Some of the vacuum systems available in the range are shown below.

EasySwitch Wet-Dry Vac is an all-purpose vacuum with the capability of handling any job — dry or wet. Switching between vacuuming liquids or solids is as easy as removing the pleated filter when vacuuming liquids and reinstalling directly into the open filter hatch when working with dry material. It is available in 205 L capacity with either standard or HEPA filtration.

Chip Vac picks up dry or wet chips and delivers them directly to an ordinary drum. It is used to clean chips from fixtures, machines, parts and work surfaces. The lid can be moved easily from drum to drum to keep materials separate for recycling. It is available in 5 gal and 205 L capacities.

Heavy Duty Dry Vac turns an ordinary drum into a powerful, industrial duty vacuum cleaner. It vacuums more dry materials in less time than ordinary vacs. It is suitable for vacuuming abrasives like steel shot, garnet, metal chips and sand. It is available in 205 L capacity with either standard or HEPA filtration.

Reversible Drum Vac is a two-way liquid vacuum that can fill or empty a 205 L drum in 90 s. It is suitable for spill recovery and filling or emptying coolant sumps. It is available in 5 gal and 205 L capacities. The High Lift Reversible Drum Vac provides the high lift power needed to fill or empty below grade (up to 4.6 m) coolant sumps, pits and cisterns.

All EXAIR industrial vacuum systems are CE certified and comply with OSHA's Safety Requirements for dead-end pressure and noise limitation.

### Compressed Air Australia Pty Ltd

[www.caasafety.com.au](http://www.caasafety.com.au)



**Ralston Instruments**

**Ralston QUICKTEST™**

### Ralston Quick-test™ Connection System

Universal pressure fitting system compatible with all standard connections

- **Low volume, high pressure hoses** for pressure testing, calibration, and leak testing
- **Leak-free instant connections** with no wrench or thread tape
- **Connect to NPT, BSPT, BSPP, Tube fitting, metric** and many other standard process connections
- **Stable, high-pressure connections** up to 35 MPa

To learn more visit [ralstoninst.com/wnipt-qts](http://ralstoninst.com/wnipt-qts) or scan the QR code

[sales@ralstoninst.com](mailto:sales@ralstoninst.com)



ISO 9001:2015 Certified • Made in the U.S.A.

## THREE-PHASE COMMERCIAL INVERTERS

The SolarEdge Synergy Inverters are three-phase commercial inverters designed for rooftop, ground mount and carport applications.

Reaching up to 100 kW, the inverters are designed to provide more power and higher profitability in large-scale commercial and industrial PV installations, as well as easier commissioning.

The inverters maximise energy production with up to 150% DC oversizing, according to the company. The system offers improved uptime through modularity and independent inverter performance. By introducing a pre-commissioning feature for in-depth visibility, installers can fully and automatically validate system components from their smartphones, before connecting to the grid. To avoid module performance degradation, the solution includes a built-in night-time PID (potential induced degradation) rectifier.

Along with integrated arc fault protection and rapid shutdown, the product offers an extra layer of protection through built-in thermal sensors on the DC and AC terminal blocks, as well as optional field-replaceable surge protection devices.

### SolarEdge Technologies Inc.

[www.solaredge.com](http://www.solaredge.com)







### PROCESS TOOL SYSTEM FOR BATTERY DEVELOPMENT

Ystral has launched the Batt-TDS series of powder dispersing systems for the development and industrial production of electrode slurries for lithium-ion batteries.

The system has the flexibility to handle diverse materials by combining multiple functions of several machines into a single core system. At R&D scale, compared to planetary mixers, which require hours of mixing to accomplish dispersion, the Batt-TDS can complete the entire process in a few minutes, enabling faster R&D cycles. Dispersion itself requires only milliseconds as components pass through its inline process chamber. At production scale, it translates to greater than 10x higher productivity than conventional technologies and twice that of available extruders, it is claimed.

Easily scalable across various battery chemistries, the solution is suitable for production at current industrial levels and ready for tomorrow's gigafactories.

The solution inducts powders dust-free under vacuum into a stream of liquid, and the technology is able to process high-solids slurries at viscosities exceeding industry requirements. A wash-in-place (WIP) feature is designed to maximise machine availability.

The product range includes a 12-L unit for rapid formulation and process screening as well as production systems for a throughput greater than 5000 L/h.

**Ystral GmbH**

<https://ystral.com/en/>



**NOW SUPPORTED BY  
PRESSURE & SAFETY SYSTEMS  
IN AUSTRALIA.**



## SMART BOILER INSTRUMENTATION

- **BOILER MONITORING**
- **LIQUID LEVEL INDICATION**
- **INDIRECT LEVEL GAUGES**
- **BOILER WATER MONITORING**
- **GERMAN EXPERTISE & QUALITY**

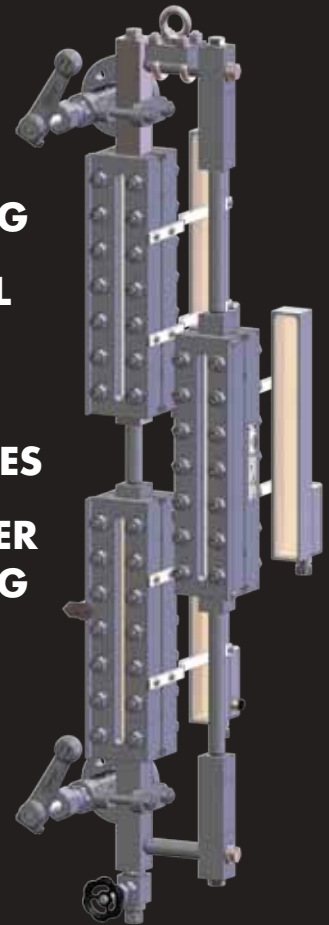

**CALL TO DISCUSS YOUR  
BOILER INSTRUMENTATION  
AND VALVE REQUIREMENTS.**

AUSTRALIAN AGENT & TECHNICAL SUPPORT

**WE HANDLE PRESSURE®**



PRESSURE & SAFETY SYSTEMS

**Tel: (03) 9699 7355**

[www.pressureandsafety.com.au](http://www.pressureandsafety.com.au)

9526838-VAN1PT

## INTELLIGENT PUMP CONTROL

Grundfos SCALA1 is an all-in-one water booster solution designed to achieve customised control over home water systems using a smartphone.

Compact and easy to install, the smart home technology solution is designed for pressure boosting in domestic and light commercial applications. The all-in-one unit includes integrating pump, motor, diaphragm tank, pressure and flow sensor, dry-running protection, controller and non-return valve.

The solution comes with a built-in two-way communication system, allowing users to track their water system anytime when in range. The Bluetooth-enabled solution allows users to monitor, control and schedule water use from their smartphone with the Grundfos GO REMOTE app, which is available for both iOS and Android operating systems.

The app alerts the user via a series of alarms that indicate issues such as leakages, dry-run, or when a pump has exceeded its maximum runtime. Users can easily access pump diagnostics, and create and email reports on-site from the app. The app also includes a calendar function designed for boosting in homes and gardens.

Applications include domestic: taps and showers in the home, garden and lawn irrigation; and light commercial: greenhouses, irrigation, car wash, produce sections in supermarkets.

**Grundfos Pumps Pty Ltd**

[www.grundfos.com](http://www.grundfos.com)



## SOLAR INVERTER AND STORAGE PLATFORMS

The FIMER PowerUNO, PowerTRIO and PowerX inverter and storage platforms are designed to help installers make the most of the increasing demand for residential solar PV and storage.

The PowerUNO and PowerTRIO inverters offer a wide range of power options from 2–8.5 kW, and feature single and three-phase options. A key benefit includes fast installation, with several easy-to-use plug and play connections allowing for a simple installation. It also has built-in high-end connectivity with Wi-Fi and ethernet, and Linux OS which allows local integration with smart home appliances and EV charging, as well as seamless interaction with FIMER's Aurora Vision cloud. In addition, it has a dedicated blockchain processor which allows utilities and aggregators to build specific use cases on top of the inverter, avoiding the need for external devices.

This approach reduces installation time and helps to mitigate cabling errors. Using a high-voltage modular battery format, PowerX provides a flexible option for capacity requirements of all sizes, with a maximum of 48 kWh, with quick and easy installation. It has a small overall footprint with a wall and floor stand — even at maximum capacity. With one module only weighing 33 kg, it also enables single person installation.

PowerX also provides the option to customise the curved front cover, and offers the choice of multiple colours to ensure the battery unit easily blends into its surroundings.

**FIMER Australia**

[www.fimer.com](http://www.fimer.com)



## IEC 61850 CLIENT COMMUNICATION MODULE

Designed for use in mining, metals and oil and gas operations, the ProSoft IEC 61850 module for ControlLogix systems is designed to allow ControlLogix control systems to interface with 61850 intelligent electronic devices (IEDs) to deliver critical equipment control and energy consumption information. This visibility can help management teams immediately improve production efficiency and optimise power use.

Industrial producers rely on hundreds of power protection relays or IEDs from manufacturers of motors, fans, conveyors, crushers, ovens and other equipment. The IEC 61850 communication module supports a standardised data structure across these devices.

The module also supports up to 40 IEDs on a parallel redundancy protocol (PRP)-enabled network and up to 225 I/O connections. It also features a generic object-oriented substation event (GOOSE) publisher to support GOOSE messaging. The GOOSE publisher provides a mechanism to interlock relays or load shed using the IEC 61850 communications network and helps eliminate hard wiring to the I/O modules.

Producers can also connect their enterprise with the PlantPax system add-on profile and custom-generated add-on instruction. The system integrates into the Studio 5000 environment from Rockwell Automation to help build complex user-defined data types and Studio 5000 tags based on an IEC 61850 network configuration.

**Rockwell Automation Australia**

[www.rockwellautomation.com/en-au.html](http://www.rockwellautomation.com/en-au.html)





# SMART HOMES

## NEED TO GET SMARTER ON ENERGY USE

*Chris Kerr, Vice President of Home & Distribution at Clipsal by Schneider Electric*

The average 'smart home' in Australia just isn't that clever. Despite the promise that the Internet of Things would seamlessly connect technology throughout our houses, it's only now that we're starting to see its potential being realised.

Home automation is set to become the key to consumers' understanding, control and improvement of their energy consumption. However, to truly empower homeowners, we need to support technology that goes beyond smart speakers and 'plug and play' options.

### Showcasing the monetary value of home automation

When it comes to 'green' technology, Australians are mostly interested in devices that provide a lifestyle benefit. Collectively, we are visibly taking small steps in the direction of home automation. It's no surprise that smart speakers in particular are driving home automation adoption, with 26% of Australians owning a Google Nest, Amazon Alexa or similar product, and accounting for a 53% increase year on year.

These products are vital to engaging homeowners in the technological advancement of their houses. However, without connection to functions such as lighting and air conditioning they fall short of the lifestyle and financial benefits offered by true home automation, while running the risk of becoming a gimmick.

While a possible part of the solution, these devices are limited unless they are incorporated into a system that offers a backbone for whole-of-home automation. It is important that affordable and accessible technologies that help visualise energy usage and creation enter the consumer market.

By educating consumers about the current and future benefits of these devices, such as connecting solar panels, photovoltaic batteries and electric vehicle chargers, whole-home automation will become more appealing to the everyday Australian — helping us create greener homes across the country.

High-end options including C-Bus have offered this connectivity for luxury homes for a number of years. Now, mass-market adoption is set to ramp up with the launch of a new, affordable and scalable system, Clipsal Wiser Smart Home. It is the opportunity for middle Australia to control everything from lighting to automated blinds from a single app. And electricians are in a unique position to help

homeowners understand the impact a smart home can have on their lifestyle, energy efficiency and back pocket.

### Flicking the switch for a greener Australia

Most importantly, smart homes also have the potential to benefit more than their occupants. In fact, the adoption of this technology within the home will help propel Australia toward a carbon-neutral future.

With the global ambition to hit net zero carbon emissions by 2050, we are seeing businesses all around the world begin to implement strategic and bold sustainability initiatives to reduce their carbon footprint, and a desire from homeowners to do the same. While this goal is more targeted globally towards corporations and large-scale buildings, residential smart homes will be key to achieving this.

Using renewable resources can dramatically lower overall household energy consumption in Australia, which is why this is set to play a large role in the race to transition from fossil-based fuels to zero carbon. In fact, renewable energy and energy efficiency measures have the potential to achieve up to 90% of the required carbon reductions.

### Leveraging the renovation revolution

Thanks to smaller, more convenient systems, installing home automation technology no longer requires major renovations. However, with \$1 billion a month on home renovations currently in progress, now is the most opportune time for Australians to consider their smart alternatives.

This is particularly critical for homeowners looking to build from the ground up. Just like large buildings, smart homes see the most impact when they are designed with the environment in mind. Industry figures estimate that 130,000 new detached homes will be built in 2021. If each of these properties harnessed smart technology, Australia would see a dramatic reduction in household energy consumption rates per year.

The future of home automation is here and growing; with it will come a range of alternatives to the energy-draining technologies that have been around for decades. Today, Australians can control their energy usage from smart lights, temperature sensor-enabled blinds, air conditioning and other electronics via a single app. They can choose what to automate as their needs change via new affordable, scalable systems to create better lifestyles for themselves and a greener, carbon-neutral future for all.

**Clipsal - by Schneider Electric**  
[www.se.com/au/en/](http://www.se.com/au/en/)



## Powering SA's electricity grid through solar farms



*Bowmans Solar Farm project in South Australia.*

Five mid- to large-scale solar farm projects will power around 5000 South Australian homes by generating electricity to the grid.

This will be undertaken as part of a long-term agreement between Yates Electrical Services Group (YES Group) and Sustainable Energy Infrastructure (SEI), to design, develop, own, operate and maintain the solar farms.

Once completed, these solar farms will deliver approximately 20 MW of electricity generation to the South Australian grid. The first two projects began construction in early 2021, with final commissioning occurring in September 2021.

The YES Group designed both solar farms to include FIMER's PVS-175 and medium-voltage compact skid inverter solutions.

"Since YES Group launched the Redmud Green Energy project five years ago in South Australia, FIMER/ABB have been a key component of our projects," said Mark Yates, Director of YES Group.

"FIMER's products are modular, flexible and scalable. Their solutions provide a simple and effective solution for installation, deployment and the ongoing operation and maintenance of medium- to large-scale

projects. This has enabled us to roll out our distributed network of solar farms — consisting of over one hundred 200 kW to 5 MW projects — throughout South Australia in a relatively short time frame and meeting a very high standard of quality."

### Bowmans Solar Farm project

The Bowmans project was the first project completed and is located 100 km north of Adelaide. The site encompasses 4400 solar panels, single-axis tracking and 11 FIMER PVS-175 string inverters combined with FIMER's PVS-175-MVCS solution. This 1.9 MW solar farm was fully commissioned in September 2021 and will produce over 4850 MWh per year or power over 750 homes.

### Renmark Solar Farm project

The Renmark project was the second project to be completed and is located 250 km northeast of Adelaide. The site encompasses over 9790 solar panels, single-axis tracking and 24 FIMER PVS-175 string inverters combined with FIMER's PVS-175-MVCS solution. This 4 MW solar farm was fully commissioned in September 2021 and will produce over 10,000 MWh per year or power over 1300 homes.

### Inverter technology

FIMER's PVS-175 is a three-phase string inverter and comes with 12 independent MPPTs for increased design flexibility and increasing yields. The fuse-free design can deliver up to 185 kVA at 800 VAC. This not only maximises the ROI for ground-mounted utility-scale applications but also reduces balance of system costs (ie, AC side cabling) for small- to large-scale, free field ground-mounted PV installations.

The PVS-175 inverters installed on both sites are connected to FIMER's medium-voltage compact skid (MVCS), which includes both LV and MV switchgear, transformer and protection in a pre-fabricated skid that enables an easy and cost-effective connection of each solar farm to the South Australian grid.

**FIMER Australia**  
[www.fimer.com](http://www.fimer.com)





# FREE

to industry and business professionals

The magazine you are reading is just **one of 11** published by Westwick-Farrow Media. To receive your **free subscription** (magazine and eNewsletter), visit the link below.



[www.WFMedia.com.au/subscribe](http://www.WFMedia.com.au/subscribe)



## Portable electronic nose sniffs out wastewater plants

Researchers from Spain have engineered a portable electronic nose (e-nose) that's almost as sharp as a human nose at sniffing out the stink of wastewater treatment plants. Coupled with a drone, the lightweight e-nose can measure the concentration of different smells, predict odour intensity and produce a real-time odour map of the plant for management.

Conventionally, a wastewater plant's odour is measured by dynamic olfactometry, where a human panel whiffs and analyses bags of air collected from the plant. Although the method has been considered the gold standard, the process is costly, slow and infrequent, which doesn't allow operators to quickly respond to problems or pinpoint the root of the stench.

To better monitor wastewater plants' odour emissions, Santiago Marco of the Institute for Bioengineering of Catalonia and his team designed a portable e-nose for real-time surveillance and data visualisation with the help of artificial intelligence (AI). The team collected bags of air from a plant and trained the e-nose to sniff out pungent chemicals such as hydrogen sulfide, ammonia and sulfur dioxide, which smell like rotten eggs, urine and burnt matches, respectively. The e-nose is also equipped with a sensor for carbon dioxide, an indicator of bacterial activity. In laboratory settings, the e-nose performed nearly as well as human noses.

The researchers then attached the 1.3 kg e-nose to a drone and sent it into the skies at a medium wastewater treatment plant in the south of

Spain between January and June. Hovering over different facilities at the plant, the 'sniffing drone' sucks in air via a 10 m tube and analyses the air in a sensor chamber.

The results demonstrated that the e-nose on a drone was feasible for wastewater odour monitoring. When analysing the same air samples in a field test, 10 out of 13 measurements from the e-nose aligned with the human panel's assessments. Aided by the drone's mobility and the AI algorithm, the team also mapped out the temporal and spatial odour concentration and, for the first time, predicted the intensity of the scent from drone measurements.

"We are extremely happy with the results, but we need more validation and to make the device more robust for a real plant operation," Marco said. The team plans to shave off some extra weight from the e-nose and develop a standardised process for the method. They are also planning to further optimise the device against the influence from temperature, humidity and other environmental conditions that can affect the accuracy.

"The work may also have implications for other facilities like landfills, composting plants or even large farms with cattle and pigs that are also known to produce all types of malodours," Marco said.

The research paper has been published in the journal *iScience*.



Image credit: Maria Desada Esclopaz



# CONTROL DEVICES



## JOYSTICK EDITION

DELIVERING YOU **EXCELLENCE** IN **ENGINEERING**

Control Devices has more than 20 years of engineering knowledge and aims to provide quality and cost-effective products and engineering solutions to optimise your operational experience and performance. We have an extensive collection of Joystick controllers, ranging from miniature to hand controlled and switched, CAN, PWM outputs and more. Custom solutions are available to suit special requirements. Suitable applications include Industrial, Mining, Automation, Marine, Defence, Agricultural and more. Get a Joystick solution today.

- ### JOYSTICK RANGE
- Fingertip Joysticks
    - Thumb Controlled
  - Hand Controlled
    - Switched Joysticks
  - Desktop USB Joysticks
  - Joystick Stations
  - Custom Design



### HANDLE & GRIP RANGE



>> CDJ900 Switched Joystick with an A Handle and rocker switch.

- |                |          |           |           |            |          |
|----------------|----------|-----------|-----------|------------|----------|
|                |          |           |           |            |          |
| HKN & CDK Knob | CDN Stem | MG Handle | HE Handle | HI Handle  | A Handle |
|                |          |           |           |            |          |
| MDG Grip       | RD1 Grip | CDG Grip  | FG Grip   | DMD Handle |          |



>> WE HAVE **MOVED**

CONTACT US FOR FURTHER INFORMATION  
 Unit 13, 538 Gardeners Road, Alexandria NSW 2015  
 02 9330 1700 sales@controldevices.net  
[www.controldevices.com.au](http://www.controldevices.com.au)





# Electrical components for machinery

- Motor protection circuit breakers
- Switch disconnectors
- Contactors
- Motor protection relays
- Electromechanical starters and enclosures
- Control and signalling units
- Limit, micro and foot switches, safety relays
- Cam switches
- Time relays
- Protection relays
- Power Supplies
- Metering instruments and current transformers
- Soft starters
- Variable speed drives
- PLCs and HMIs
- Servo motors and drives



**Lovato**  
electric

**DELTA**

**Mechtronic**  
ELECTRICAL AND MECHANICAL ENGINEERING PRODUCTS

[mechtronic.com.au](http://mechtronic.com.au)

**Sydney 02 9676 1671**  
**Melbourne 03 9706 4599**  
**Brisbane 07 3274 3327**  
**Adelaide 08 8347 2499**  
**Perth 08 9248 0410**