



RF INTERCONNECT

FULL LINE SOLUTIONS CATALOG

PRECISION 50 Ω (18 TO 110 GHz) • STANDARD 50 Ω & 75 Ω (SUB-6 GHz & 12G-SDI) • TECH SUPPORT

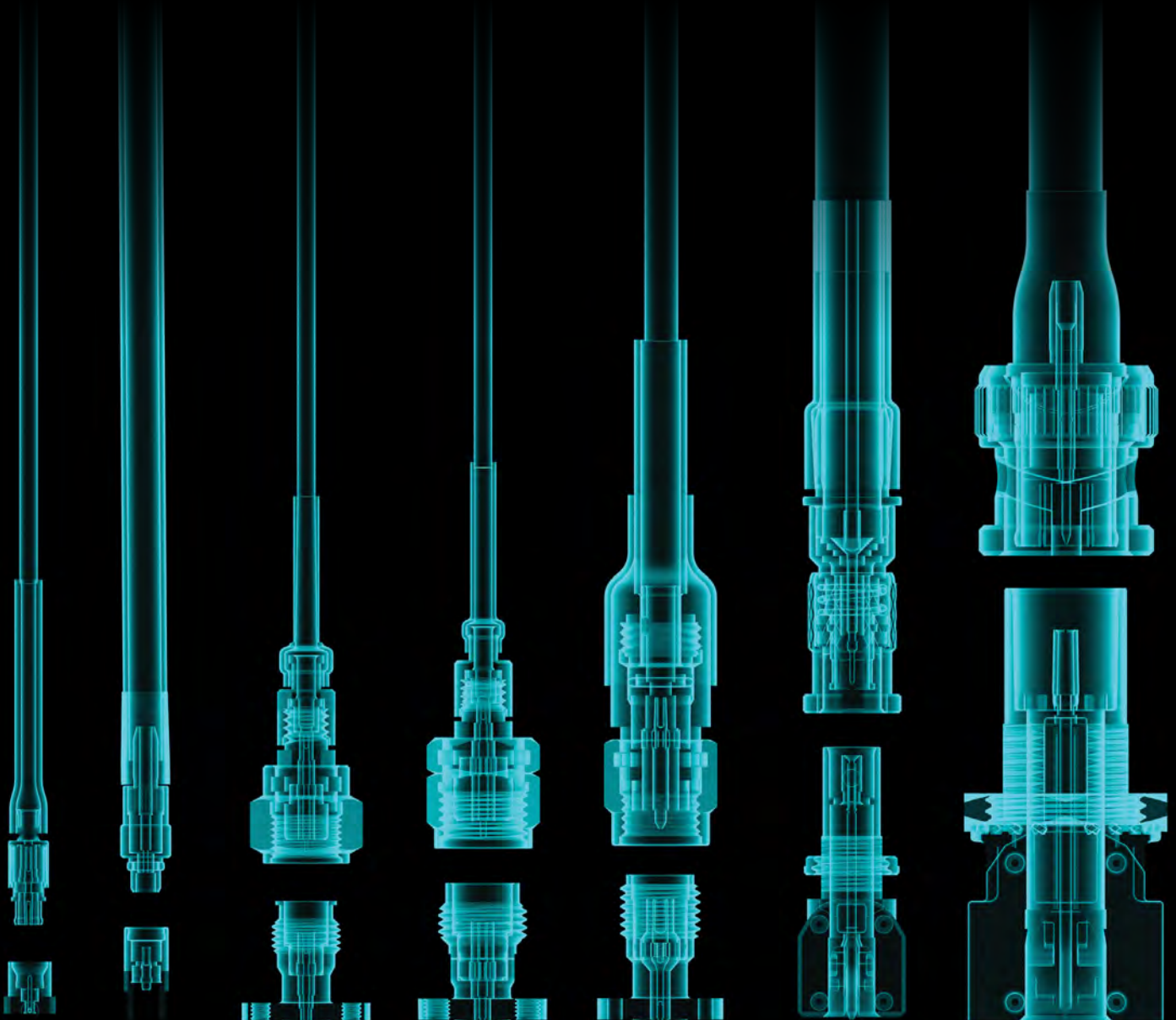

TABLE OF CONTENTS

CABLE ASSEMBLIES

8-31

Precision RF 50 Ω
(18 GHz to 110 GHz)

32-45

Standard RF 50 Ω & 75 Ω
(Sub-6 GHz & 12G-SDI)



CABLE CONNECTORS

12-25

Precision RF 50 Ω
(18 GHz to 110 GHz)

34-44

Standard RF 50 Ω & 75 Ω
(Sub-6 GHz & 12G-SDI)



BOARD CONNECTORS

12-25

Precision RF 50 Ω
(18 GHz to 110 GHz)

34-45

Standard RF 50 Ω & 75 Ω
(Sub-6 GHz & 12G-SDI)



ADAPTORS

26-27

Precision RF 50 Ω
(In-Series & Between-Series)



ORIGINAL RF SOLUTIONS

11

Precision RF

45

Low Frequency



Sudden Service® & Online Tools	4-5
RF Product Overview	6-7
Nitrowave™ Cable	9
Magnum RF® Solutions for Ganged Cable-to-Board or Board-to-Board Applications	20-21
Bulls Eye® Solutions for 40 GHz, 50 GHz, 70 GHz & 90 GHz	28-30
Flexible Waveguide Technology for Frequencies up to 90 GHz (E-band)	31
Customs & Tech Support	46
Index	47

SILICON-TO-SILICON™ SOLUTIONS

SOLUTIONS EXCEEDING TODAY'S CONNECTIVITY DEMANDS

As bandwidth, scale and power requirements continue to challenge conventional engineering methods, we want to help **optimize the landscape of your entire system** – and develop solutions, together.

Samtec's industry-leading signal integrity expertise, full system optimization strategies and, innovative products and technologies help address the challenges of next gen data transmission for **a path to 224 Gbps and beyond**.

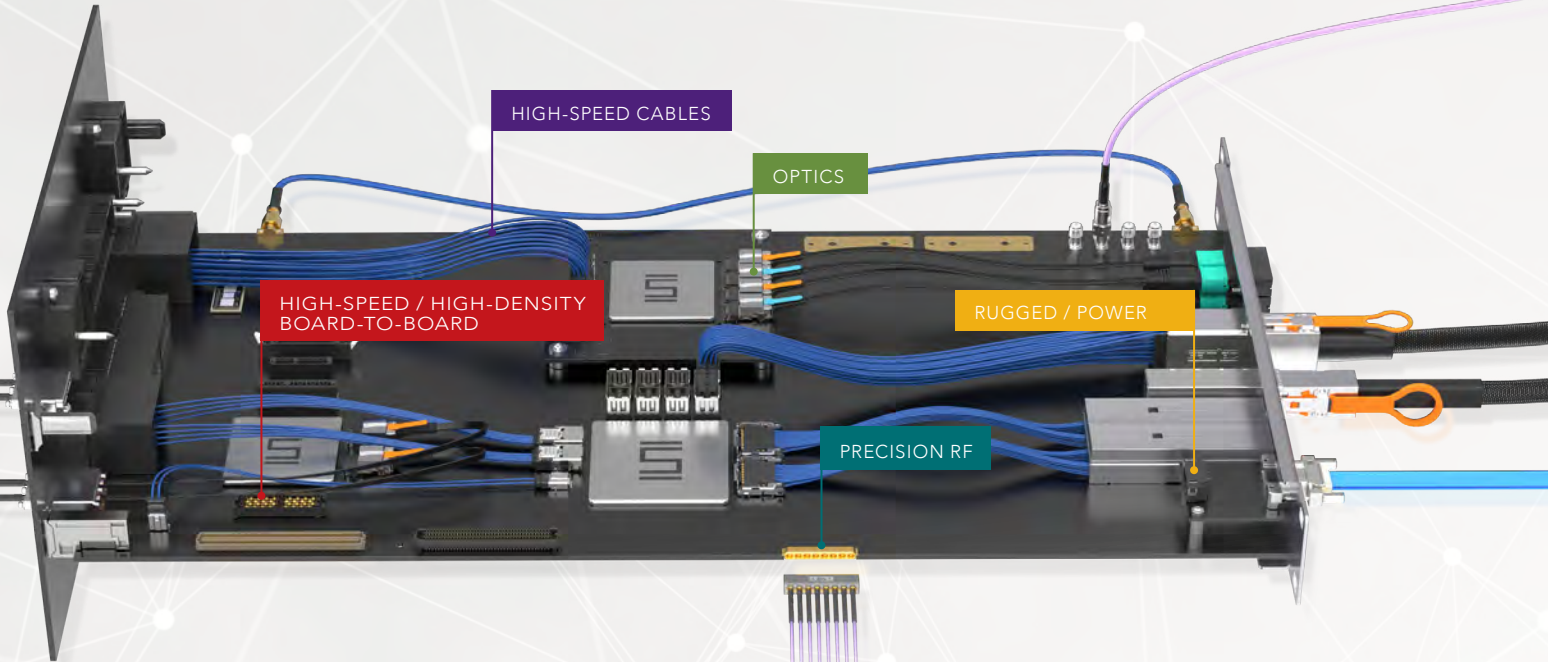

INTEGRATION LEADS TO INNOVATION

COMPLETE SYSTEM OPTIMIZATION FROM SILICON-TO-SILICON™

Samtec's integrated approach provides high-level design and development of advanced interconnect systems and **TECHNOLOGIES**, along with industry-leading expertise that allows us to offer effective strategies and support for **optimizing the entire signal channel of high-performance systems**.

Samtec is structured like no other company in the interconnect industry. We work in a fully integrated capacity that enables true collaboration and results in uniquely innovative **PRODUCTS** because **our technology teams are not limited by the boundaries of traditional business units**.

SUDDEN SERVICE®

Samtec's Sudden Service® provides unmatched global service, free access to data and industry leading tools, along with engineering support, to help you design, develop, test and deliver the best solution for any complex application.

GLOBAL OPERATIONS & SUPPORT NETWORK



AWARD-WINNING SERVICE

#1 in Bishop's Customer Survey of the Electronic Connector Industry.



Samtec has been consistently rated as the #1 connector company in North America, Europe and Asia. This is the highest overall rating in the Bishop & Associates' U.S., Europe and Asia Customer Surveys of the Electronic Connector Industry.

UNMATCHED LEAD-TIMES

Innovative Programs & Systems Enable Deliveries in Days, Not Weeks.

Reserve®

SHIPS TOMORROW

This designation allows customers to **quickly and easily identify availability of over 200,000 of Samtec's most popular connectors and cables - guaranteed to ship in 1-day.**

Look for the **Reserve®** badge throughout **samtec.com** to quickly determine if your part number is eligible, along with current availability, quantity breaks and pricing. Hundreds of part numbers are being added daily!

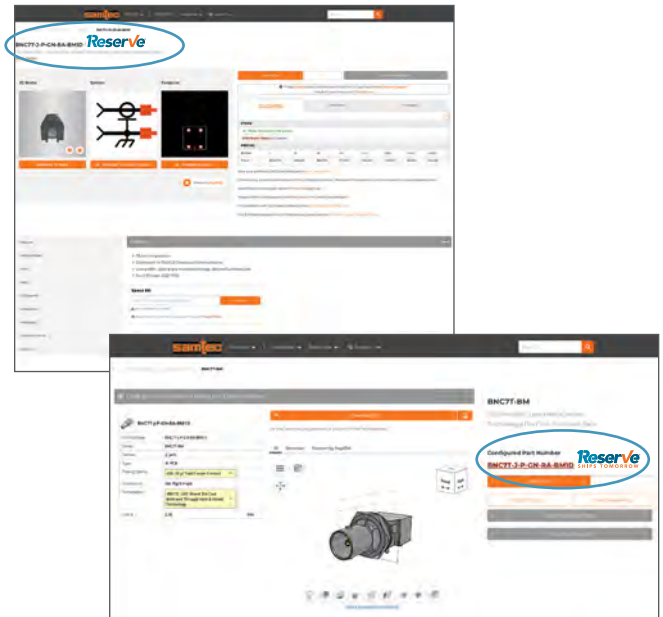

Free product samples, shipped in 24-hours or less have been a cornerstone of Samtec Sudden Service® since the company was founded. Visit **samtec.com** to quickly request your sample.

An innovative shipping program that **bridges the gap between manufacturing facilities and customers**, allowing for manufacturing flexibility without increased costs, and with even faster lead-times. Contact **ecustomerservice@samtec.com** to learn more.

24/7 WORLDWIDE ACCESS

Samtec is the Electronics Industry's Service & Technology Leader.

Technical Support

Signal Integrity Group: sig@samtec.com

Application Support Group: asg@samtec.com

Interconnect Processing Group: ipg@samtec.com

RF Group: RFGroup@samtec.com

Supply Chain Support

MySamtec™ Real-Time Account Access: account.samtec.com

Personal Account Managers & CSRs: ecustomerservice@samtec.com

Upfront, Aggressive 24-Hour Quotes: pricing@samtec.com

COMPLETE RF INTERCONNECT SOLUTIONS

PRECISION 50 Ω (18 to 110 GHz) • STANDARD 50 Ω & 75 Ω (SUB-6 GHz & 12G-SDI) • TECH SUPPORT

Samtec offers complete RF interconnect solutions supporting traditional sub-6 GHz frequencies to 110 GHz microwave/mmWave frequencies (sub-Terahertz spectrum). Products include end-to-end RF cable assemblies, board connectors, cable connectors, adaptors and Samtec Original RF solutions.

Technical Support

High-level design and development of advanced interconnect systems, along with industry leading expertise, allows us to offer effective strategies and support for optimizing the entire signal channel.

RF technical support includes launch optimization, simulation and testing. Customization of products, both quick-turn modifications or new designs, is also available.

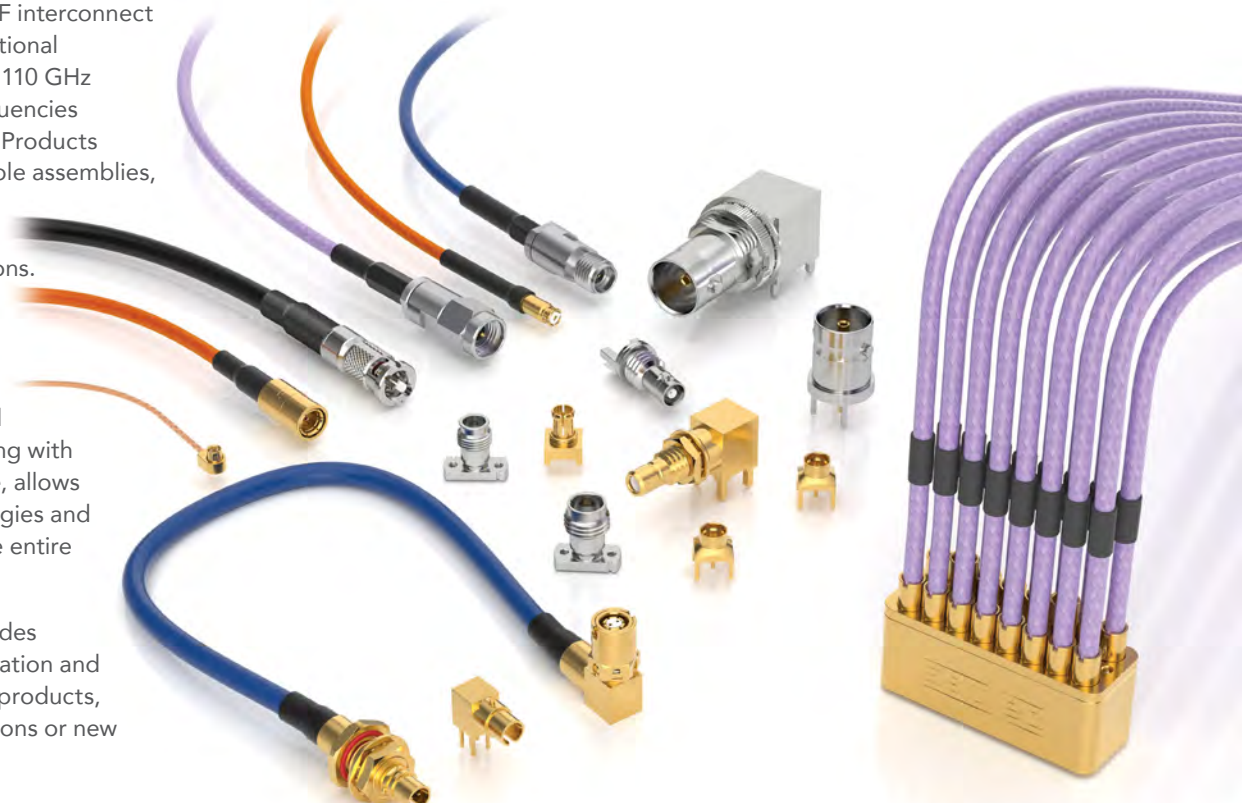

Applications

- Test and Measurement
- Military, Aerospace, Satellite, Radar
- 5G/6G, Low Latency Wireless Communications
- Automotive, Telematics
- Broadcast & 12G-SDI
- Industrial, Monitoring, Instrumentation

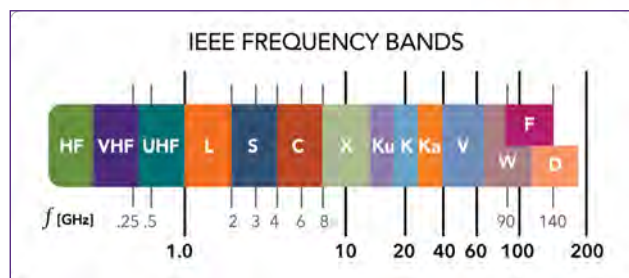

PRECISION RF, 50 Ω

Interface	1.00 mm	1.35 mm	1.85 mm	2.40 mm	2.92 mm	3.50 mm	SSMA	SMA	Ganged SMPM	SMPM	SMP	N Type	TNCA
Frequency	110 GHz	90 GHz	65 GHz	50 GHz	40 GHz	34 GHz	34 GHz	18/26.5 GHz	65 GHz	65 GHz	40 GHz	18 GHz	18 GHz

STANDARD RF, 50 Ω & 75 Ω

Interface	MHF	SMA	MCX	MMCX	TNC	BNC (50 Ω)	SMB (50 & 75 Ω)	Ganged (50 & 75 Ω)	BNC (75 Ω)	HD BNC (75 Ω)	DIN 1.0/2.3 (75 Ω)
Frequency	6 GHz	6 GHz	6 GHz	6 GHz	6 GHz	4 GHz	4 GHz	5 GHz	12 GHz	12 GHz	12 GHz

CABLE ASSEMBLIES

- Precision, high frequency or standard, low frequency
- Assemblies available with the following cable types:
 - Low-loss microwave/millimeter wave from .047 to .277, semi-flexible
 - New **Nitrowave™** cable! Phase and amplitude stable with flexure, with an outer jacket colored in **distinctive Samtec orange**. Performance is optimized for next generation frequency targets.
 - RG type (316, 174, 178, 58, 179, 6)
 - 12G-SDI optimized
 - 0.81 mm and 1.13 mm Micro High Frequency (MHF)
- Discrete and ganged solutions
- Cable lengths standard up to 10 meters (> 10 meters as custom RSP)
- Phase matching in pairs down to 1 ps
- Cable management available
- **Mix & Match Solutions for Any Application:** Samtec offers a variety of end options for each product series; this blends application-specific customization with the simplicity and lead-time efficiencies of an off-the-shelf assembly



BOARD CONNECTORS, CABLE CONNECTORS & ADAPTORS

- Precision, high frequency or standard, low frequency solutions
- Board-to-board or cable-to-board applications
- Threaded, bulkhead, push-on or bayonet coupling
- Solderless compression mount: vertical & edge launch
- Soldered: through-hole, surface mount, edge mount or mixed technology
- Balanced connectors for high-volume pick-and-place automation
- 12G-SDI optimized broadcast video solutions (BNC, High-Density BNC, DIN 1.0/2.3)
- Cable connectors for use with industry standard cables: offer the flexibility to terminate to an industry-standard cable specified for your application
- Adaptors for 50 Ω precision RF applications: in-series and between-series



Ganged Solutions



Complete Mated Sets



50 Ω , 75 Ω & 12G-SDI Solutions



Precision Interconnects

PRECISION RF

MICROWAVE / MILLIMETER WAVE CABLE ASSEMBLIES & INTERCONNECTS

Samtec's RF product line includes 18 to 110 GHz High Frequency, Precision RF solutions for microwave and mmWave applications, including full cable assemblies, cable connectors and board level interconnects. Our focus is on delivering high-quality RF products that meet precision and performance expectations, blended with industry-leading system-level signal integrity expertise.

Vertical Integration = Full System Support

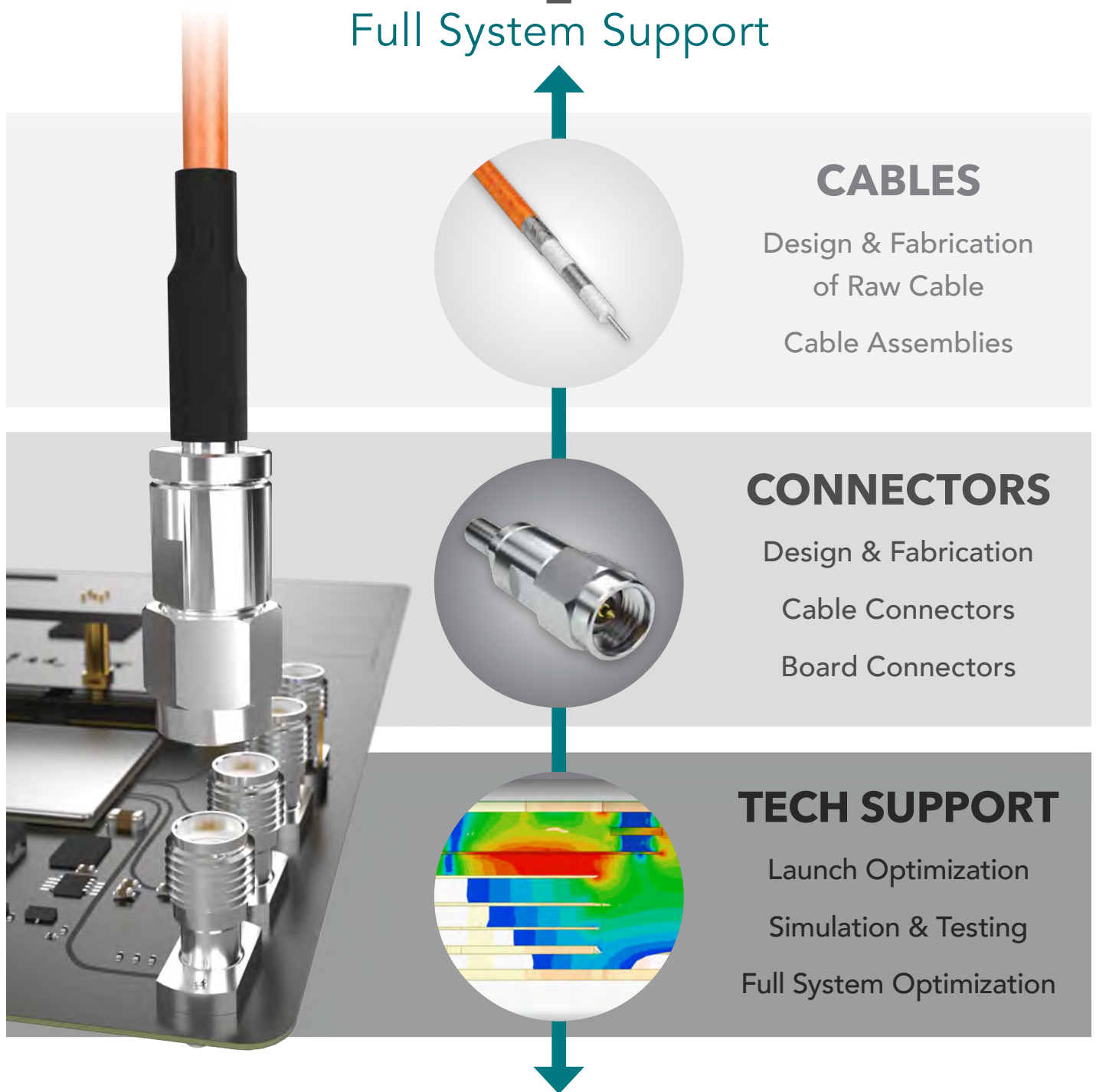

NITROWAVE™ CABLE TECHNOLOGY



HIGH-PERFORMANCE, PHASE & AMPLITUDE STABLE

DC TO
110
GHz

Samtec's new **Nitrowave™ Phase & Amplitude Stable RF Cable** offers improved stability with flexure over time. The coaxial structure – with an outer jacket colored in **distinctive Samtec orange** – is designed to meet the demands of aerospace, defense, datacom, computer/semiconductor, and instrumentation markets. Performance is optimized at frequencies beyond traditional industry targets to support emerging applications.

NITROWAVE™ CABLE TECHNOLOGY

- High-performance, low-loss microwave cable assemblies
- Phase and amplitude stable with flexure
- Consistent contact resistance between layers
- Lower density dielectric minimizes loss
- State-of-the-art shielding techniques and interlayer
- Silver plating enhancements mitigate corrosion potential
- Electrical performance optimized at next gen frequencies (GHz): 18, 32, 43.5, 71, 95, 110
- Mechanical and environmental robustness
- Phase vs. Bending = $< 0.2^\circ \times F(\text{GHz})$
- VSWR = 1.4:1 @ 43.5 GHz (LL043 Series)
- Typical phase vs. temp & power handling



Series	LL018	LL032	LL043*	LL071	LL095	LL110
Impedance (Ω)	50					
Max Frequency (GHz)	18	32	43.5	71	95	110
Outer Dia. (inches)	0.306	0.192	0.143	0.096	0.078	0.068
Min Static Bend Radius	1.25	0.375	0.25	0.25	0.125	0.125
Velocity of Propagation (%)	77					
Min Shielding Effectiveness (dB)	-100					
Temp Range (°C)	-65 °C to +125 °C					
Insertion Loss	See Maximum IL Chart					
End 1/End 2	1.00 mm, 1.35 mm, 1.85 mm, 2.40 mm, 2.92 mm, SMPM, SMP, SMA, N Type, TNCA					

MAXIMUM INSERTION LOSS (dB/m)

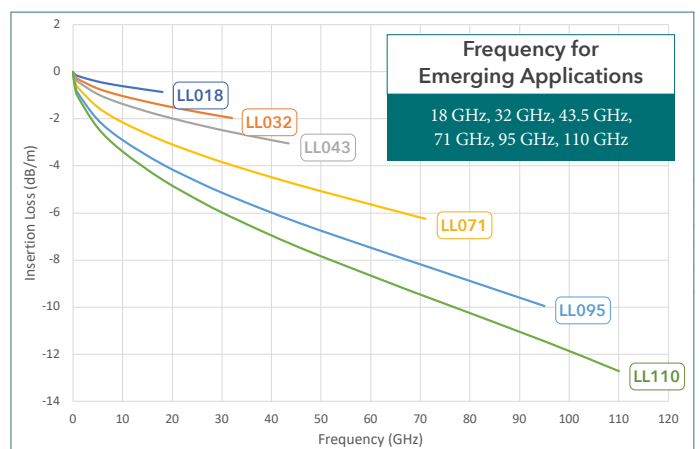

*Visit www.samtec.com?LL043 for more information about the LL043 Series.

50 Ω μWAVE/mmWAVE CABLE SPECIFICATIONS

STANDARD OFF-THE-SHELF ASSEMBLIES

SERIES	RF047-A	RF25S	RF40S	RF085	RF086	RF23C	RF23S	RF402	RF180	RF280	
TYPE	.047 (29 AWG), low loss flexible	Samtec 25 AWG, flexible	RG 40S, .086, (24 AWG), semi- flexible	.085 (24 AWG), low loss flexible	.086 (23 AWG), low loss flexible	Samtec 23 AWG, flexible, copper shield	Samtec 23 AWG, flexible	RG 402, .141 (19 AWG), semi- flexible	.178 (16 AWG), low loss flexible	.277 (11 AWG), low loss flexible	
ELECTRICAL											
Max. Frequency (GHz)	110	40	20	50	67	50	35	20	27	18	
Max. Insertion Loss (dB/m)	1 GHz	1.21	0.79	0.72	0.69	0.65	0.68	0.72	0.40	0.27	0.17
	26 GHz	7.43	3.80 @ 20 GHz	4.26 @ 20 GHz	4.28	3.90	4.27	3.71 @ 20 GHz	2.30 @ 20 GHz	1.23 @ 18 GHz	0.79 @ 18 GHz
	40 GHz	9.68	–	–	5.59	5.06	5.59	–	–	–	–
	50 GHz	11.14	–	–	6.47	5.81	6.46	–	–	–	–
Propagation Delay (ns/m)	4.76		4.79	4.75	4.20	4.76	4.72	4.79	4.17	4.02	
Velocity of Propagation	70%				80%	70%		70%	80%	83%	
Capacitance (pF/m)	95.00	96.80	104.97	88.20	83.37	97.80	95.45	98.07	82.00		
CONSTRUCTION											
Center Conductor	Material	Solid Silver Plated Copper									
	AWG (mm/in.)	29 (.2870 / .0113)	25 (.4570 / .0180)	24 (.5100 / .0200)		23 (.5740 / .0226)			19 (.9200 / .0362)	16 (1.3000 / .0512)	11 (2.2600 / .0889)
Dielectric	Material	PFA	Solid FEP	PTFE	Solid PTFE	Foam FEP	FEP	Solid FEP	PTFE	PTFE Tape	
	Dia. (mm/in.)	.9220 / .0363	1.4700 / .0578	1.6800 / .0660	1.6300 / .0640	1.6150 / .0636	1.8470 / .0727	1.8470 / .0727	2.9800 / .1170	3.6800 / .1450	6.3500 / .2500
Shield	Material	1) Ag Plated Cu 2) Ag Plated Cu		Tinned Cu	Spiral Strip Ag Plated Cu	1) Ag Plated Cu 2) Ag Plated Cu	1) Ag Plated Cu 2) Cu Tape 3) Ag Plated Cu	1) Ag Plated Cu 2) Ag Plated Cu	Tinned Cu	1) Flat Ag Plated Cu 2) Al Polyester 3) Round Ag Plated Cu	
Outer Braid	Dia. (mm/in.)	1.1700 / .0460	1.8600 / .0735	2.2000 / .0860	2.1300 / .0840	2.1080 / .0830	2.2730 / .0895	2.2480 / .0885	3.5800 / .1410	4.5200 / .1780	7.0400 / .2770
Jacket	Material	FEP		–	FEP			–	FEP		
	Dia. (mm/in.)	1.4200 / .0560	2.0600 / .0810	3.2000 / .1260	2.6400 / .1040	2.5400 / .1000	2.6670 / .1050	2.5900 / .1020	4.5800 / .1803	4.9500 / .1950	7.6200 / .3000
MECHANICAL											
Operating Temp	-65° C to 125° C	-40° C to 200° C	-40° C to 125° C	-65° C to 125° C	-55° C to 125° C	-65° C to 125° C	-40° C to 200° C	-40° C to 150° C	-55° C to 200° C		
Min. Bend Radius	3.18 mm	9.00 mm	6.35 mm	13.20 mm	8.90 mm	3.18 mm	8.89 mm	10.90 mm	24.80 mm	38.10 mm	
Connector Options	1.00 mm, 1.35 mm, 1.85 mm, 2.40 mm, 2.92 mm, SMA, SMP, SMPM, Ganged SMPM (Magnum RF®)	SMA, SMP		2.92 mm, 2.40 mm	1.85 mm, 2.40 mm, 2.92 mm, SMA, SMP, SMPM, Ganged SMPM (Magnum RF®)	2.40 mm, 2.92 mm, SMA, SMP, SMPM	3.50 mm	SMA	SMA, TNCA, N Type	SMA, TNCA, N Type	

For complete specifications, visit samtec.com or contact RFGroup@samtec.com

ORIGINAL SOLUTIONS PRECISION RF

PRECISION ALIGNMENT FEATURES

- Eliminates misalignment that can occur during board assembly
- Ensures repeatable peak connector performance
- Available on 135, 185, 240, 292 & GPPC Series

DIFFERENTIAL PAIR TEST & MEASUREMENT

- Two-port SMPM ganged solution (GPPC Series)
- Solderless compression mount design
- Saves board real estate (2x the spacing savings)
- Cable-to-board or board-to-board

RIGHT-ANGLE, LOW PROFILE, GANGED SMPM

- Extremely low profile, high-density, right-angle connector (GPPC Series, -RA-SM option)
- Belly-to-belly, surface mount PCB connection for maximum density
- Body height: 3.94 mm (.155")

COUNTERWEIGHT SOLUTIONS

- Enables efficient board assembly (eliminates hand soldering)
- Balanced for automated, high-volume pick-and-place automation
- Edge mount SMA (26.5 GHz) or 2.92 mm (40 GHz)

ANALOG OVER ARRAY™ CONNECTORS

- Enhanced open-pin-field arrays simultaneously run analog, digital, and power signals
- Reference designs and evaluation kits
- Industry-leading crosstalk and return loss performance

DC TO
90
GHz

DC TO
65
GHz

DC TO
65
GHz

DC TO
40
GHz

DC TO
15
GHz



SERIES	135/185/240/292/GPPC	GPPC (-CMM)	GPPC (-RA-SM)	RSP (SMA/2.92 mm)	ANALOG OVER ARRAY™
Application	Precision Alignment	Differential Pair Testing	Extremely Low Profile	Balanced Edge Mount	Analog, Digital & Power
URL	samtec.com/alignment	samtec.com?GPPC	samtec.com?GPPC	Contact: RFGroup@samtec.com	samtec.com/AOA
PRODUCT FAMILY	BULLS EYE®	FLEXIBLE WAVEGUIDE	VNX+™	MAGNUM RF®	
URL	samtec.com/BullsEye	samtec.com/Waveguide	samtec.com/VNX-plus	samtec.com/magnumRF	

VITA/VNX/VNX+/FMC/FMC+/XMC/XMC+ are all respective trademarks of VITA

1.00 mm TO 110 GHz

1.00 mm Cable Assemblies RF047-A



SERIES	END 1 CONNECTOR	END 2 CONNECTOR	OVERALL LENGTH
RF047-A = (1.2 mm) .047" overshield DIA 29 AWG millimeter wave cable	-10BJ = 1.00 mm Bulkhead Straight Jack -10SP = 1.00 mm Straight Plug		-“XXXX” = Overall Length in millimeters -0100 (100 mm) 3.94" minimum

ALSO AVAILABLE

1.35 mm, 1.85 mm, 2.40 mm, 2.92 mm,
SMPM, SMP, SMA = RF047-A

VSWR

1.40 max. (DC to 90 GHz)
1.50 max. (90 GHz to 110 GHz)

1.00 mm Board Connectors 100

Cable Mates:
RF047-A



100	GENDER	TYPE	PLATING	ORIENTATION	TERMINATION	OPTION	PACKAGING
-----	--------	------	---------	-------------	-------------	--------	-----------

-J
= Jack

-P
= PCB Mount

-VP
= 50 μ"
(1.27 μm)
Gold center contact,
Passivated outer body

-ST
= Straight

-EL
= Edge Launch

-01
= .040" to
.100" PCB
thickness

Leave blank for
individually
bagged

-B
= Bulk
packaged

PRELIMINARY

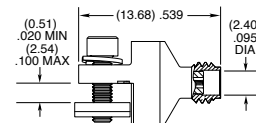
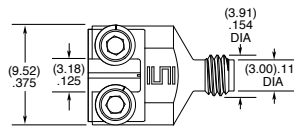

1.00 mm Cable Connectors PRF10



CONNECTORS FOR INDUSTRY STANDARD CABLES	
PRF10-J-C-VP-047D-SS	.047 Semi-Rigid
PRF10-P-C-VP-047D-SS	.047 Semi-Rigid

For a complete list of 1.00 mm cable connectors, visit www.samtec.com?PRF10

J-C = Cable Jack

P-C = Cable Plug

VP = Plating (75 μ" Gold center contact, passivated outer contact)

SS = Straight, Solder Clamp

INTERFACE STANDARD

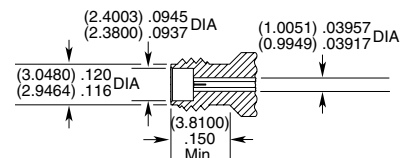
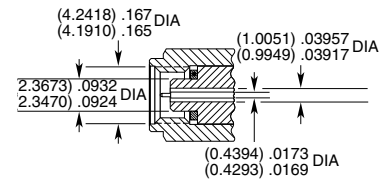

1.35 mm TO 90 GHz

1.35 mm Cable Assemblies RF047-A



SERIES	END 1 CONNECTOR	END 2 CONNECTOR	OVERALL LENGTH
RF047-A = (1.2 mm) .047" overshield DIA 29 AWG millimeter wave cable	-13BJ = 1.35 mm Bulkhead Straight Jack -13SP = 1.35 mm Straight Plug		-“XXXX” = Overall Length in millimeters -0100 (100 mm) 3.94" minimum

ALSO AVAILABLE

1.00 mm, 1.85 mm, 2.40 mm, 2.92 mm,
SMPM, SMP, SMA = RF047-A

VSWR

RF047-A: 1.40 max.

1.35 mm Board Connectors 135

Cable Mates:
RF047-A



135	GENDER	TYPE	PLATING	ORIENTATION	TERMINATION	OPTION	PACKAGING
	-J = Jack	-P = PCB Mount	-VP = 50 μ" (1.27 μm) Gold center contact, Passivated outer contact	-ST = Straight	-CM = Compression Mount Stripline -CMM = Compression Mount Microstrip	-1 = Without screws -2 = With screws	Leave blank for individually bagged. -B = Bulk packaged

-CMM

-CM

1.35 mm Cable Connectors PRF13



CONNECTORS FOR INDUSTRY STANDARD CABLES	
PRF13-P-C-VP-047A-SS	Temp-Flex 1000671047
PRF13-J-C-VP-047A-BS	Temp-Flex 1000671047

For a complete list of 1.35 mm cable connectors, visit www.samtec.com?PRF13
P-C = Cable Plug
J-C = Cable Jack
VP = Plating (75 μ" Gold center contact, passivated outer contact)
SS = Straight, Solder Clamp
BS = Bulkhead, Solder Clamp

INTERFACE STANDARD

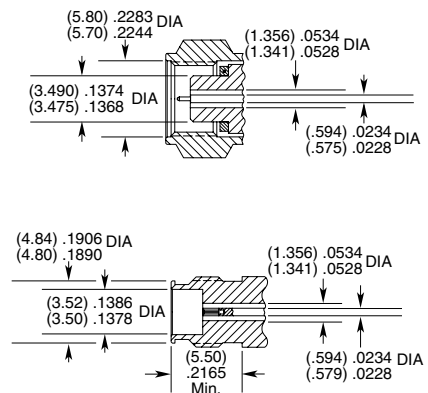

1.85 mm TO 65 GHz

1.85 mm Cable Assemblies

RF047-A, RF086



VSWR

RF047-A: 1.40 max.
RF086: 1.40 max.

SERIES	END 1 CONNECTOR	END 2 CONNECTOR	OVERALL LENGTH
--------	-----------------	-----------------	----------------

RF047-A
= (1.2 mm) .047" overshield DIA 29 AWG millimeter wave cable

RF086
= (2.18 mm) .086" overshield DIA 23 AWG millimeter wave cable

-18SJ
= 1.85 mm Straight Jack

-18SP
= 1.85 mm Straight Plug

-"XXXX"
= Overall Length in millimeters

-0100 (100 mm) 3.94" minimum

ALSO AVAILABLE

1.00 mm, 1.35 mm, 2.40 mm,
2.92 mm, SMPM, SMP, SMA = RF047-A

2.40 mm, 2.92 mm, SMPM, SMP, SMA = RF086

1.85 mm Board Connectors

185

Cable Mates:
RF047-A, RF086



185	GENDER	TYPE	PLATING	ORIENTATION	TERMINATION	OPTION	PACKAGING
-----	--------	------	---------	-------------	-------------	--------	-----------

-J
= Jack

-P
= PCB Mount

-EP
= 50 μ" (1.27 μm) Gold center contact, Passivated outer contact

-ST
= Straight

-CM
= Compression Mount Stripline

-CMM
= Compression Mount Microstrip

-1
= Without Screws (-CM & -CMM only)

-2
= With Screws (-CM & -CMM only)

Leave blank for individually bagged.

-B
= Bulk packaged

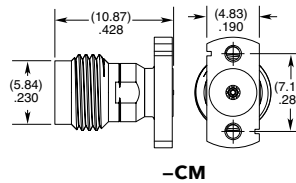
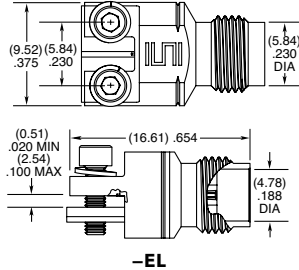

1.85 mm Cable Connectors

PRF18



CONNECTORS FOR INDUSTRY STANDARD CABLES	
PRF18-J-C-EP-085-BS	Harbour SS405
PRF18-P-C-EP-085-SS	Harbour SS405
PRF18-P-C-EE-085-SD	Harbour SS405
PRF18-J-C-EP-086-SS	Temp-Flex 1001935086
PRF18-J-C-EP-047A-SS	Temp-Flex 1000671047
PRF18-P-C-EP-047A-SS	Temp-Flex 1000671047
PRF18-J-C-EP-047D-SS	.047 Semi-Rigid
PRF18-P-C-EP-047D-SS	.047 Semi-Rigid
PRF18-P-C-EE-047D-SD	.047 Semi-Rigid
PRF18-P-C-EE-047H-SD	EZ-47-LA Semi-Rigid
PRF18-P-C-EP-070-SD	EZ-70-LA Semi-Rigid
PRF18-J-C-EE-405-SD	RG 405 Semi-Rigid
PRF18-P-C-EE-405-SD	RG 405 Semi-Rigid
PRF18-P-C-EP-086E-SS	Dynawave DF165

For a complete list of 1.85 mm cable connectors, visit www.samtec.com?PRF18

INTERFACE STANDARD

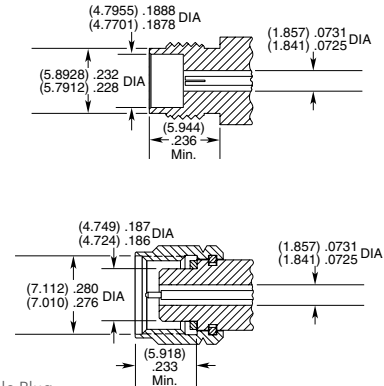

P-C = Cable Plug
J-C = Cable Jack
EE = Plating (50 μ" gold center contact, & outer contact)
EP = Plating (50 μ" gold center contact, passivated outer contact)
SS = Straight, Solder Clamp
SD = Straight, Direct Solder
BS = Bulkhead, Solder Clamp

2.40 mm TO 50 GHz

2.40 mm Cable Assemblies

RF047-A, RF085,
RF086, RF23C



VSWR

RF047-A: 1.35 max.
RF086: 1.40 max.
RF085: 1.40 max.
RF23C: 1.40 max.

SERIES

RF047-A

= (1.2 mm) .047" overshield DIA 29 AWG millimeter wave cable

RF086

= (2.18 mm) .086" overshield DIA 23 AWG millimeter wave cable

RF085

= (2.16 mm) .085" overshield DIA 24 AWG millimeter wave cable

RF23C

= MWC-2350CU-01 millimeter wave cable with copper foil shield

END 1 CONNECTOR

-24SJ

= 2.40 mm Straight Jack

-24SP

= 2.40 mm Straight Plug

END 2 CONNECTOR

OVERALL LENGTH

-“XXXX”

= Overall Length in millimeters

-0100 (100 mm)
3.94" minimum

ALSO AVAILABLE

1.00 mm, 1.35 mm, 1.85 mm,
2.92 mm, SMPM, SMP, SMA = RF047-A

1.85 mm, 2.92 mm, SMPM, SMP, SMA = RF086

2.92 mm = RF085

2.92 mm, SMPM, SMP, SMA = RF23C

2.40 mm Board Connectors

240

Cable Mates:

RF047-A, RF086,
RF085, RF23C



240 - GENDER - TYPE - PLATING - ORIENTATION - TERMINATION - OPTION - PACKAGING

-J

= Jack

-P

= PCB Mount

-EP

= 50 μ" (1.27 μm) Gold center contact, Passivated outer contact

-ST

= Straight

-CM

= Compression Mount Stripline

-CMM

= Compression Mount Microstrip

-EL

= Edge Launch

-1

= Without Screws (-CM & -CMM only)

-2

= With Screws (-CM & -CMM only)

-01

= .040" to .100" PCB thickness (-EL only)

Leave blank for individually bagged

-B = Bulk packaged

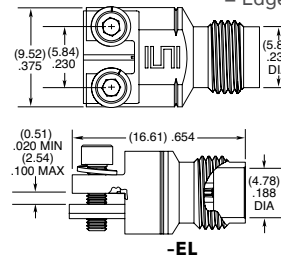
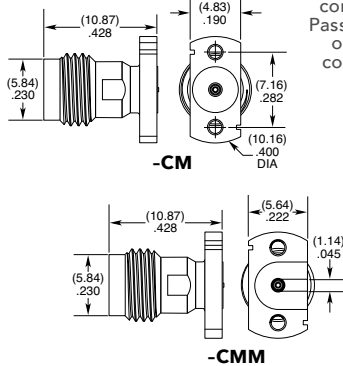

2.40 mm Cable Connectors

PRF24



CONNECTORS FOR INDUSTRY STANDARD CABLES

PRF24-J-C-EP-085-SS	Harbour SS405
PRF24-J-C-EP-405-BS	RG 405
PRF24-P-C-EE-085-SS	Harbour SS405
PRF24-P-C-EP-120A-SD	Semflex HP120
PRF24-J-C-EP-160-SS	Semflex HP160
PRF24-P-C-EP-160-SS	Semflex HP160
PRF24-J-C-EP-140B-SS	IW 1401
PRF24-P-C-EP-140B-SS	IW 1401
PRF24-J-C-EP-150B-SS	IW 1501
PRF24-J-C-EP-150-SS	Dynawave DF150
PRR24-J-C-EP-086-SS	Temp-Flex 1001935086
PRF24-P-C-EP-086-SS	Temp-Flex 1001935086

For a complete list of 2.40 mm cable connectors, visit www.samtec.com?PRF24

P-C = Cable Plug

J-C = Cable Jack

EE = Plating (50 μ" gold center contact & outer contact)

EP = Plating (50 μ" gold center contact, passivated outer contact)

SS = Straight, Solder Clamp

SD = Straight, Direct Solder

BS = Bulkhead, Solder Clamp

INTERFACE STANDARD

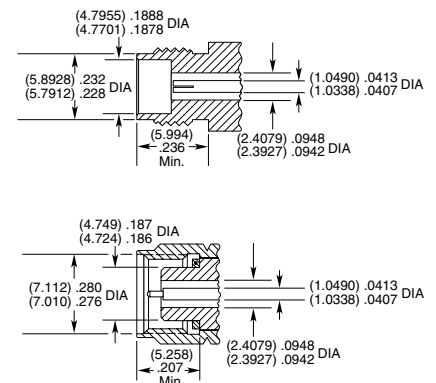

2.92 mm TO 40 GHz

2.92 mm Cable Assemblies

RF047-A, RF086, RF085, RF23C



VSWR

RF047-A: 1.35 max.
RF086: 1.40 max.
RF085: 1.40 max.
RF23C: 1.40 max.

SERIES	END 1 CONNECTOR	END 2 CONNECTOR	OVERALL LENGTH
RF047-A = (1.2 mm) .047" overshield DIA 29 AWG millimeter wave cable	-92SJ = 2.92 mm Straight Jack		-“XXXX” = Overall Length in millimeters -0100 (100 mm) 3.94" minimum
RF086 = (2.18 mm) .086" overshield DIA 23 AWG millimeter wave cable	-92SP = 2.92 mm Straight Plug		
RF085 = (2.16 mm) .085" overshield DIA 24 AWG millimeter wave cable			
RF23C = MWC-2350CU-01 millimeter wave cable with copper foil shield			
ALSO AVAILABLE			
1.00 mm, 1.35 mm, 1.85 mm, 2.40 mm, SMPM, SMP, SMA = RF047-A			
1.85 mm, 2.40 mm, SMPM, SMP, SMA = RF086			
2.40 mm = RF085			
2.40 mm, SMPM, SMP, SMA = RF23C			

2.92 mm Board Connectors

292

Cable Mates:
RF047-A, RF085,
RF086, RF23C



292	GENDER	TYPE	PLATING	ORIENTATION	TERMINATION	OPTION	PACKAGING
	-J = Jack	-P = PCB Mount	-EP = 50 μ" (1.27 μm) Gold center contact, Passivated outer contact	-ST = Straight	-CM = Compression Mount Stripline -CMM = Compression Mount Microstrip	-1 = Without Screws (-CM & -CMM only) -2 = With Screws (-CM & -CMM only) -01 = .040" to .100" PCB thickness (-EL only)	Leave blank for individually bagged. -B = Bulk packaged
					-EL = Edge Launch		

2.92 mm Cable Connectors

PRF92



CONNECTORS FOR INDUSTRY STANDARD CABLES	
PRF92-P-C-EE-405-SD	RG 405 Semi-Rigid
PRF92-P-C-EE-085A-SD	.085 Semi-Rigid
PRF92-P-C-EP-160-SS	Semflex HP160
PRF92-P-C-EP-150B-SS	IW 1501
PRF92-P-C-EP-142-SS	Harbour LL142
PRF92-J-C-EP-085-SS	Harbour SS405
PRF92-J-C-EP-085-BS	Harbour SS405
PRF92-P-C-EP-085-SS	Harbour SS405
PRF92-P-C-EE-402-SD	RG 402
PRF92-P-C-EP-190-SS	Semflex HP190
PRF92-J-C-EP-160-SS	Semflex HP160
PRF92-P-C-EP-120A-SS	Semflex HP120
PRF92-P-C-EP-140-SS	Dynawave DF140
PRF92-P-C-EP-047D-SS	.047 Semi-Rigid
PRF92-J-C-EP-047D-SS	.047 Semi-Rigid
PRF92-P-C-EP-150-SS	Dynawave DF150
PRF92-P-C-EE-118-SD	Haverhill HC35004
PRF92-J-C-EP-402-SS	RG 402
PRF92-J-C-EP-047D-4S	.047 Semi-Rigid
PRF92-P-C-EP-086-SS	Temp-Flex 1001935086
PRF92-P-C-EP-200-SS	Times Max Gain 200

For a complete list of 2.92 mm cable connectors, visit www.samtec.com?PRF92

INTERFACE STANDARD

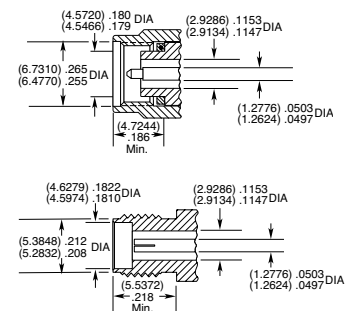

P-C = Cable Plug
J-C = Cable Jack
EE = Plating (50 μ" Gold center contact & outer contact)
EP = Plating (50 μ" Gold center contact, passivated outer contact)
SS = Straight, Solder Clamp
SD = Straight, Direct Solder
BS = Bulkhead, Solder Clamp
4S = 4-hole flange, Solder Clamp

3.50 mm TO 34 GHz

3.50 mm Cable Assemblies RF235



VSWR

RF235: 1.30 max

SERIES

RF235
= MWC-2350-01 microwave cable with 23 AWG solid FEP Dielectric

END 1 CONNECTOR

-35SJP
= 3.50 mm Straight Jack

-35SPP
= 3.50 mm Straight Plug

END 2 CONNECTOR

OVERALL LENGTH

-"XXXX"
= Overall Length in millimeters
-0100 (100 mm) 3.94" min.

3.50 mm Cable Connectors PRF35



CONNECTORS FOR INDUSTRY STANDARD CABLES

PRF35-P-C-EP-405-SS	RG 405, Semi-Rigid
PRF35-J-C-EP-402-SS	RG 402, .141, Semi-Rigid
PRF35-J-C-EP-402-BS	RG 402, .141, Semi-Rigid
PRF35-P-C-EP-402-SS	RG 402, .141, Semi-Rigid
PRF35-P-C-EP-120A-SS	Semflex HP120
PRF35-J-C-EP-160-SS	Semflex HP160
PRF35-P-C-EP-160-SS	Semflex HP160
PRF35-P-C-EP-210A-SS	Micro-Coax UFA210A

For a complete list of 3.50 mm cable connectors, visit www.samtec.com?PRF35

P-C = Cable Plug

J-C = Cable Jack

EP = Plating (50 μ" Gold center contact, passivated outer contact)

SS = Straight, Solder Clamp

BS = Bulkhead, Solder Clamp

INTERFACE STANDARD

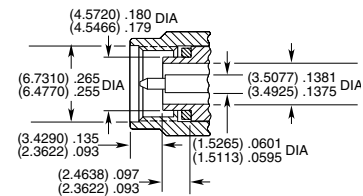
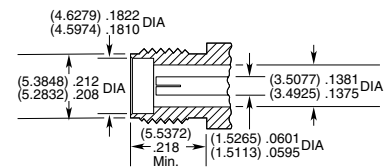

SSMA TO 34 GHz

SSMA Cable Connectors PRFS1



CONNECTORS FOR INDUSTRY STANDARD CABLES

PRFS1-J-C-EE-405-BD	RG 405, Semi-Rigid
PRFS1-P-C-EE-405-SD	RG 405, Semi-Rigid
PRFS1-P-C-EP-141A-SS	Harbour SS402

For a complete list of SSMA cable connectors, visit www.samtec.com?PRFS1

P-C = Cable Plug

J-C = Cable Jack

EE = Plating (50 μ" Gold center contact & outer contact)

EP = Plating (50 μ" Gold center contact, passivated outer contact)

SS = Straight, Solder Clamp

SD = Straight, Direct Solder

BD = Bulkhead, Direct Solder

INTERFACE STANDARD

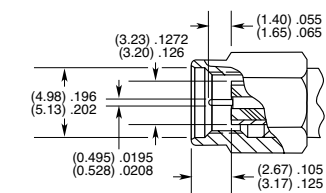
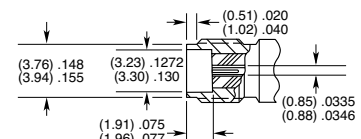

SMA TO 26.5 GHz

SMA Cable Assemblies

RF047-A, RF086, RF23C, RF25S, RF402, RF405, RF180, RF280

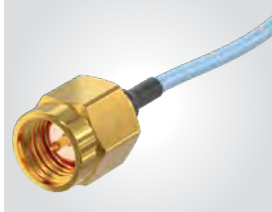

VSWR

RF047-A: 1.30 max.
RF086: 1.30 max.
RF23C: 1.30 max.
RF180: 1.35 max.
RF280: 1.35 max.

Additional connector options available. Contact RFGroup@samtec.com

SERIES	END 1 CONNECTOR	END 2 CONNECTOR	OVERALL LENGTH
RF047-A = (1.2 mm) .047" overshield DIA 29 AWG millimeter wave cable	-01SP1* = SMA Straight Plug		-“XXXX” = Overall Length in millimeters
RF086 = (2.18 mm) .086" overshield DIA 23 AWG millimeter wave cable	-01RP1* = SMA Right-angle Plug (RF047-A, RF086, RF23C & RF25S not available)		-0100 (100 mm) 3.94" minimum (RF047-A, RF086, RF23C, RF25S, RF402, & RF405)
RF23C = MCW-2350CU-01 millimeter wave cable with copper foil shield	-01BJ1* = SMA Bulkhead Jack (RF402 & RF405 not available)		-0152 (152 mm) 5.984" minimum (RF180)
RF25S = MWC-2550-01 microwave cable with 25 AWG solid FEP dielectric	-01SB = Straight Bulkhead Jack, Sealed (RF047-A, RF086 & RF23C only)		-0200 (200 mm) 7.87" minimum (RF280)
RF402 = RG 402 (.141") 19 AWG semi-flexible microwave cable	*Remove last "1" from end connector when specifying RF047-A, RF086, RF23C, RF180 & RF280.		
RF405 = RG 405 (.086") 24 AWG semi-flexible microwave cable	ALSO AVAILABLE		
RF180 = (4.52 mm) .178" overshield DIA, 16 AWG microwave cable	1.00 mm, 1.35 mm, 1.85 mm, 2.40 mm, 2.92 mm, SMPM, SMP = RF047-A		
RF280 = (7 mm) .277" overshield DIA, 11 AWG microwave cable	1.85 mm, 2.40 mm, 2.92 mm, SMPM, SMP = RF086		
	2.40 mm, 2.92 mm, SMPM, SMP = RF23C		
	SMP = RF25S, RF405		
	TNCA, N Type = RF180		
	TNCA, N Type = RF280		

SMA Board Connectors

SMA-TH, SMA-SM, SMA-MT, SMA-EM

Cable Mates:
 RF047-A, RF086, RF23C, RF25S, RF402, RF405, RF180, RF280



SMA	GENDER	TYPE	PLATING	ORIENTATION	TERMINATION
	-J = Jack	-P = PCB Mount	-H = 30 μ" (0.76 μm) Gold center contact, 3 μ" (0.08 μm) Gold outer contact	-ST = Straight	-TH1 = Through-hole
			-GF = 10 μ" (0.25 μm) Gold center contact, 3 μ" (0.08 μm) Gold outer contact (-SM1 only)	-RA = Right-angle	-SM1 = Surface Mount (-GF-RA only)
					-EM1 = Edge Mount (-ST only)
					-EM3 = Drop-in Edge Mount (-ST only)
					-MT1 = Mixed Technology (-ST only)

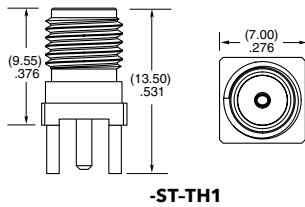

SMA Cable Connectors

PRF01



CONNECTORS FOR INDUSTRY STANDARD CABLES		
PRF01-P-C-EP-120C-SS		Harbour LL120
PRF01-J-C-EP-142-SS		Harbour LL142
PRF01-P-C-EP-142-SS		Harbour LL142
PRF01-P-C-EP-142-RS		Harbour LL142
PRF01-P-C-EP-142A-SS		Harbour SB142
PRF01-P-C-EP-335-SS		Harbour LL335
PRF01-P-C-EP-335A-SS		Harbour LL335i
PRF01-P-C-EP-190-SS		Semflex HP190
PRF01-P-C-EP-190-RS		Semflex HP190
PRF01-P-C-EP-305-SS		Semflex HP305
PRF01-P-C-EP-290-SS		Semflex LA290

For a complete list of SMA cable connectors, visit www.samtec.com?PRF01

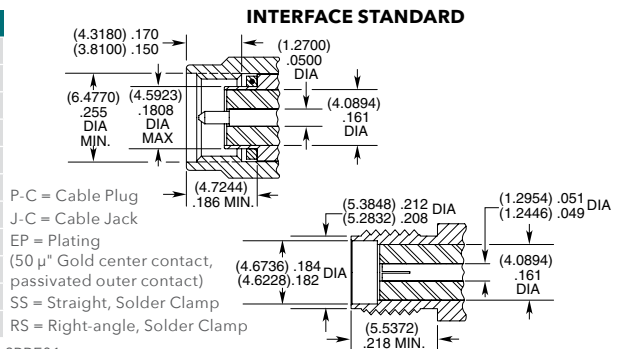

SMMP TO 65 GHz

SMMP Cable Assemblies

RF047-A, RF086, RF23C



VSWR

RF047-A: 1.40 max.
RF086: 1.40 max.
RF23C: 1.20 max. (DC to 26.5 GHz)
 1.40 max. (26.5 GHz to 50 GHz)

SERIES	END 1 CONNECTOR	END 2 CONNECTOR	OVERALL LENGTH
RF047-A = (1.2 mm) .047" overshield DIA 29 AWG millimeter cable RF086 = (2.18 mm) .086" overshield DIA 23 AWG millimeter cable RF23C = MWC-2350CU-01 millimeter wave cable with copper foil shield	-MOSP = SMMP Straight Plug, Full Detent -MOSJ = SMMP Straight Jack -MORJ = SMMP Right-angle Jack (RF047-A only) -MOBJ = SMMP Straight Bulkhead Jack (RF047-A only)	-"XXXX" = Overall Length in millimeters -0100 (100 mm) 3.94" minimum	

ALSO AVAILABLE

1.00 mm, 1.35 mm, 1.85 mm, 2.40 mm,
 2.92 mm, SMP, SMA = RF047-A
 1.85 mm, 2.40 mm, 2.92 mm, SMP, SMA = RF086
 2.40 mm, 2.92 mm, SMP, SMA = RF23C

SMMP Board Connectors

SMPM-SM, SMPM-TH, SMPM-RA, SMPM-MT, SMPM-EM

Cable Mates:
 RF047-A, RF086, RF23C

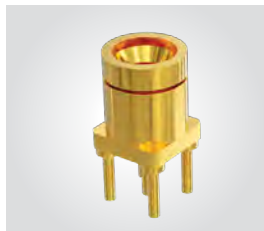

SMMP	GENDER	TYPE	PLATING	ORIENTATION	TERMINATION	OPTION
	-PF = Full Detent -PS = Smooth Bore -PC = Catcher's Mitt (-ST-TH, -ST-MT & -ST-SM only)	-P = PCB Mount	-HG = 30 μ" (0.76 μm) Gold center contact, 10 μ" (0.25 μm) Gold outer contact (-ST only) -HF = 30 μ" (0.76 μm) Gold center contact, 3 μ" (0.08 μm) Gold outer contact (-RA only) -EG = 50 μ" (1.27 μm) Gold center contact, 10 μ" (0.25 μm) Gold on body (-MT & -SM only) -EE = 50 μ" (1.27 μm) extra heavy Gold center contact and outer body (SM-2 only)	-ST = Straight -RA = Right-angle (-TH required)	-EM = Drop-in Edge Mount (-ST only) -TH = Through-hole -SM = Surface Mount (-ST only) -MT = Mixed Technology (-ST only)	-1 = Standard -2 = Reverse Mount (-EE and -SM only; see website for print)
 -ST-TH-1	 -RA-TH-1	 -ST-SM-1	 -ST-EM-1			

SMMP Cable Connectors

PRFM0



CONNECTORS FOR INDUSTRY STANDARD CABLES

PRFM0-J-C-EE-085-BD	Harbour SS405
PRFM0-J-C-EE-047A-BD	Temp-Flex 1000671047
PRFM0-J-C-HG-047A-SD	Temp-Flex 1000671047
PRFM0-J-C-EE-047A-RD	Temp-Flex 1000671047
PRFM0-P-C-HG-047A-SD	Temp-Flex 1000671047
PRFM0-J-C-EE-047B-SD	Temp-Flex 1001935047
PRFM0-J-C-EE-086-SD	Temp-Flex 1001935086
PRFM0-P-C-EE-086-SD	Temp-Flex 1001935086

For a complete list of SMMP cable connectors, visit www.samtec.com?PRFM0

INTERFACE STANDARD (CATCHER'S MITT)

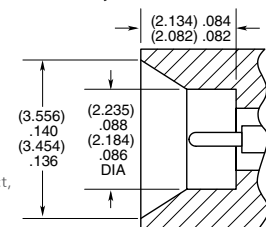

P-C = Cable Plug
 J-C = Cable Jack
 EE = Plating
 (50 μ" Gold center contact,
 & outer contact)
 HG = Plating
 (30 μ" Gold center contact,
 10 μ" Gold outer contact)
 SD = Straight, Direct Solder
 BD = Bulkhead, Direct Solder
 RD = Right-angle, Direct Solder

SMPM TO 65 GHZ

SMPM Ganged Cable: GC47, GC86

Mates With: GPPC

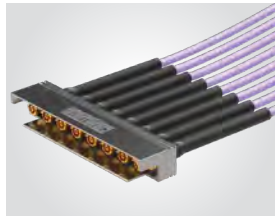

SERIES	NO. OF ROWS	NO. OF POSITIONS	ASSEMBLY LENGTH
--------	-------------	------------------	-----------------

GC47
= Ganged SMPM with (1.2 mm) .047" overshield DIA 29 AWG millimeter wave cable

GC86
= Ganged SMPM with (2.18 mm) .086" overshield DIA 23 AWG millimeter wave cable

-1

-02, -04, -06, -08, -10

-"XXXX"
= Assembly Length in millimeters -0100 (100 mm) 3.94" minimum

NO. OF POSITIONS	A	B
-02	(8.89) .350	(3.56) .140
-04	(16.00) .630	(10.67) .420
-06	(22.10) .870	(17.78) .700
-08	(30.23) 1.190	(24.89) .980
-10	(37.34) 1.470	(32.00) 1.260

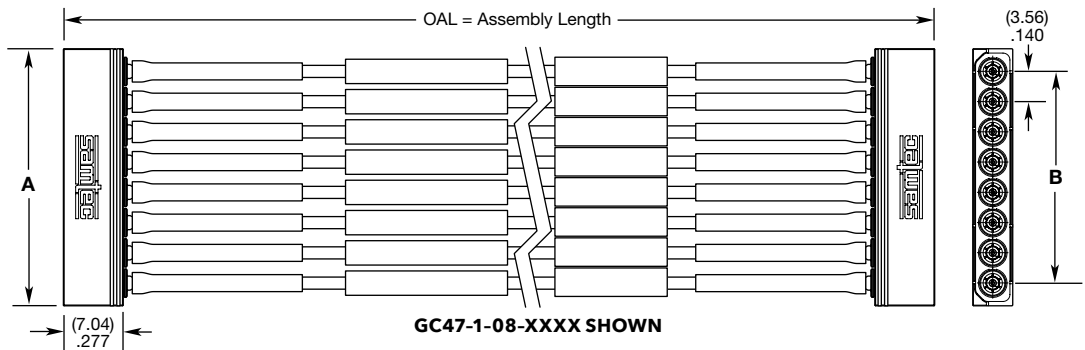

ALSO AVAILABLE

Other RF options for end 2
Contact RFGroup@samtec.com

Notes:
Cable lengths longer than 1000 mm (39.37") are not supported with S.I. test data.

Some sizes, styles and options are non-standard, non-returnable.

SMPM Ganged Block: GPPC

Mates With: GC47, GC86



GPPC	GENDER	1	NO. OF POSITIONS	PLATING	ORIENTATION	TERMINATION	1N
------	--------	---	------------------	---------	-------------	-------------	----

-PF
= Plug Full Detent

-PS
= Plug Smooth Bore

-PC
= Catcher Mitt (-ST-SL & -RA-SM only)

-02, -04, -06, -08, -10 (Per Row)

-EG
= 50 μm (1.27 μm) heavy Gold center contact, 10 μm (0.25 μm) extra Gold outer body (-EM only)

-HG
= 30 μm (0.76 μm) Gold center contact, 10 μm (0.25 μm) Gold outer body (-SL & -SM only)

-ST
= Straight

-RA
= Right-angle (-SM only)

-SM
= Surface Mount (Right-angle only)

-EM
= Edge Mount

-SL
= Stub Launch

Leave blank for -SL & -SM

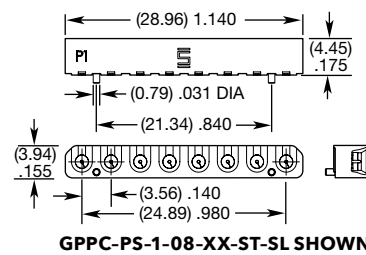

NO. OF POSITIONS	A	B	C	D	E
-02	(9.35) .368	(7.70) .303	(3.56) .140	(7.62) .300	N/A
-04	(16.46) .648	(14.81) .583	(10.67) .420	(14.73) .580	(7.11) .280
-06	(23.57) .928	(21.92) .863	(17.78) .700	(21.84) .860	(14.22) .560
-08	(30.68) 1.208	(29.03) 1.143	(24.89) .980	(28.96) 1.140	(21.34) .840
-10	(37.80) 1.488	(36.14) 1.423	(32.00) 1.260	(36.07) 1.420	(28.45) 1.120

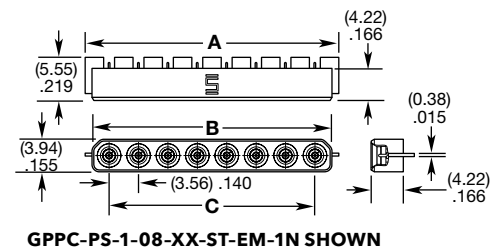
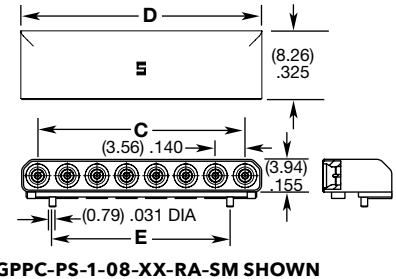

Notes:
Some sizes, styles and options are non-standard, non-returnable.

SMPM TO 65 GHz

SMPM Ganged Block: GPPB

Mates With: PRFIA

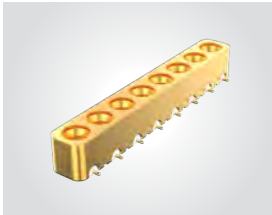

GPPB	GENDER	NO. OF ROWS	NO. OF POSITIONS	PLATING	ST	SM	CHANNEL PITCH
------	--------	-------------	------------------	---------	----	----	---------------

- PF** = Plug Full Detent
- PS** = Plug Smooth Bore
- PC** = Catcher's Mitt
- 1**
- 02, -04, -06, -08, -10**
- EG** = 50 μ" (1.27 μm) heavy Gold center contact, 10 μ" (0.25 μm) Gold outer body
- 1N** = 3.56 mm (.140") Pitch

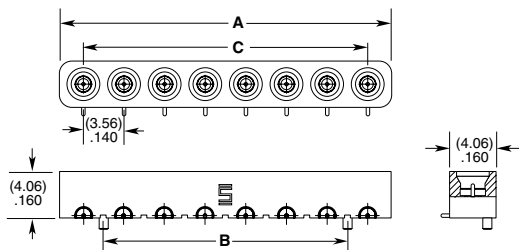

NO. OF POSITIONS	A	B	C
-02	(7.62) .300	N/A	(3.56) .140
-04	(14.73) .580	(7.11) .280	(10.67) .420
-06	(21.84) .860	(14.22) .560	(17.78) .700
-08	(28.96) 1.14	(21.34) .840	(24.89) .980
-10	(36.07) 1.42	(28.45) 1.12	(32.00) 1.26

GPPB-PF-1-08-EG-ST-SM-1N SHOWN

ALSO AVAILABLE

(8.33 mm) .328" Pitch
 (5.08 mm) .200" Pitch
 Edge Mount termination
 Contact: RFGroup@samtec.com

DUAL PORT SOLDERLESS COMPRESSION MOUNT

SMPM Ganged Block: GPPC

Mates With: GC47, GC86, PRFIA



GPPC	GENDER	1	2	PLATING	ORIENTATION	TERMINATION	PACKAGING
------	--------	---	---	---------	-------------	-------------	-----------

- PF** = Plug Full Detent
- PS** = Plug Smooth Bore
- EP** = 50 μ" (1.27 μm) heavy Gold center contact, Passivated outer body
- ST** = Straight
- CMM** = Compression Mount
- Leave blank for Individually bagged
- B** = Full Tray (Multiples of 100 required)

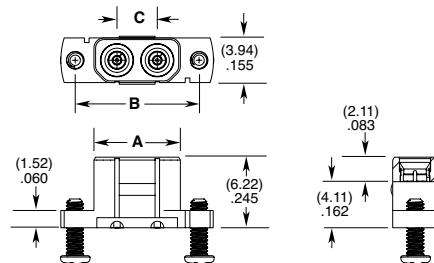

NO. OF POSITIONS	A	B	C
-02	(7.62) .300	(10.92) .430	(3.56) .140

GPPC-PX-1-2-EP-ST-CMM-X SHOWN

See Page 26 for SMPM In-Series Bullet Adaptors or visit Samtec.com?PRFIA

SMP TO 40 GHz

SMP Cable Assemblies

RF047-A, RF086, RF23C, RF25S, RF405

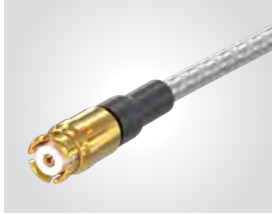

VSWR

RF047-A: 1.50 max.
RF086: 1.50 max.
RF23C: 1.50 max.
RF25S: Contact Samtec
RF405: Contact Samtec

SERIES	END 1 CONNECTOR	END 2 CONNECTOR	OVERALL LENGTH
RF047-A = (1.2 mm) .047" overshield DIA 29 AWG millimeter wave cable	-00SJ = SMP Straight Jack (RF047-A, RF086 & RF23C only)		-“XXXX” = Overall Length in millimeters
RF086 = (2.18 mm) .086" overshield DIA 23 AWG millimeter wave cable	-00MJ = SMP Right-angle Jack (RF047-A, RF086 & RF23C only)		-0100 (100 mm) 3.94" minimum
RF23C = MWC-2350CU-01 millimeter wave cable with copper foil shield	-00BF = SMP Bulkhead Jack, Full Detent (RF086 & RF23C only)		
RF25S = MWC-2550-01 microwave cable with 25 AWG solid FEP dielectric	-00BL = SMP Bulkhead Jack, Limited Detent (RF086 & RF23C only)		
RF405 = RG 405 (.086") 24 AWG semi-flexible microwave cable	-00BS = SMP Bulkhead Jack, Smooth Bore (RF086 & RF23C only)		
	-00BC = SMP Bulkhead Jack, Catcher's Mitt (RF086 & RF23C only)		
	-00SJ7 = SMP Straight Jack (RF25S & RF405 only)		
	-00RJ7 = SMP Right-angle Jack (RF25S & RF405 only)		

ALSO AVAILABLE

1.00 mm, 1.35 mm, 1.85 mm, 2.40 mm, 2.92 mm, SMPM, SMA = RF047-A
 1.85 mm, 2.40 mm, 2.92 mm, SMPM, SMA = RF086
 2.40 mm, 2.92 mm, SMPM, SMA = RF23C
 SMA = RF25S
 SMA = RF405

SMP Cable Connectors

PRF00



CONNECTORS FOR INDUSTRY STANDARD CABLES	
PRF00-J-C-EE-047A-RD	Temp-Flex 1000671047
PRF00-J-C-EE-085A-SD	.086 Semi-Rigid
PRF00-PF-C-KK-047D-BD	.047 Semi-Rigid

For a complete list of SMP cable connectors, visit www.samtec.com?PRF00

J-C = Cable Jack

EE = Plating (50 μ" Gold center contact & outer contact)

KK = Plating (100 μ" Gold over Nickel center contact, passivated outer contact)

BD = Bulkhead, Direct Solder

SD = Straight, Direct Solder

RD = Right-angle, Direct Solder

INTERFACE STANDARD (FULL DETENT)

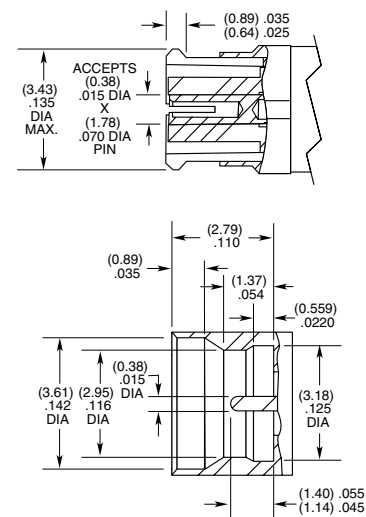

SMP TO 40 GHz

SMP Board Connectors

SMP-TH, SMP-EM,
SMP-MT, SMP-SM

Cable Mates:

RF047-A, RF086,
RF23C, RF405, RF25S

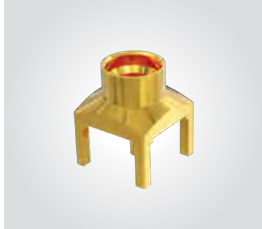

SMP	GENDER	TYPE	PLATING	ORIENTATION	TERMINATION
-----	--------	------	---------	-------------	-------------

-PF
= Plug, Full Detent

-PL
= Plug, Limited Detent

-PS
= Plug, Smooth Bore

-PC
= Plug, Catcher's Mitt

-P
= PCB Mount

-HG
= 30 μ" (0.76 μm)
Gold center contact,
10 μ" (0.25 μm)
Gold outer body

-ST
= Straight

-SM
= Surface Mount
(Not available with PS)

-TH"X"
= Through-hole
(Specify "X"
from chart)

-MT"X"
= Mixed Technology
(Specify "X"
from chart)

-EM
= Edge Mount
(-PL & -PS only)

OPTION (X)	A (HEIGHT DIM.)	BOARD THICKNESS
1 (-MT only)	(5.88) .2315	(1.60 mm) .062" PCB
2 (-MT only)	(6.72) .2645	(2.36 mm) .093" PCB
3 (-TH only)	(5.88) .2315	(1.60 mm) .062" PCB
4 (-TH only)	(6.72) .2645	(2.36 mm) .093" PCB

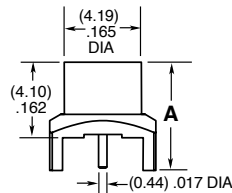

-PF/-PL/-PS-TH2

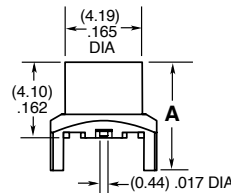

-MT(X)

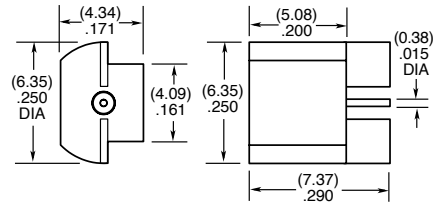

-EM

ALSO AVAILABLE

Low Frequency options.
Contact RFGroup@samtec.com

SMP Bullet Adaptor

SMP-B



SMP	J	TYPE	PLATING	ORIENTATION	BULLET LENGTH
-----	---	------	---------	-------------	---------------

-B
= Bullet Adaptor

-HG
= 30 μ" (0.76 μm)
Gold center contact,
10 μ" (0.25 μm)
Gold outer body

-ST
= Straight

-0591*
= (5.91 mm) .233"

-0645
= (6.45 mm) .254"

-0690*
= (6.90 mm) .272"

-0795*
= (7.95 mm) .313"

-0896*
= (8.96 mm) .353"

-1305*
= (13.05 mm) .514"

-1450
= (14.50 mm) .571"

**PRELIMINARY*

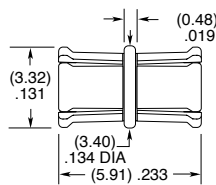

-0591

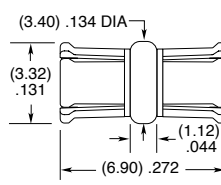

-0690

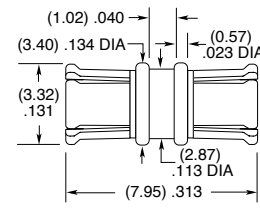

-0795

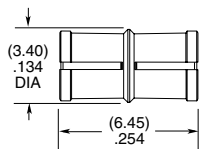

-0645

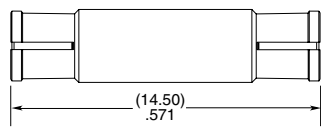

-1450

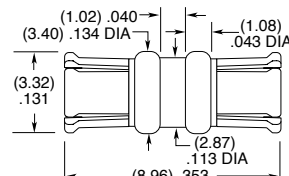

-0896

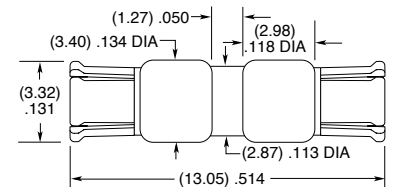

-1305

N TYPE TO 18 GHz

N Type Cable Assemblies

RF180, RF280



VSWR

RF 180:
1.35 max. (-06SP & -06BJ)
1.45 max. (-06RP)

RF 280:
1.35 max. (-06SP & -06BJ)
1.35 max. (DC to 14 GHz) (-06RP)
1.50 max. (14 GHz to 18 GHz)

SERIES	END 1 CONNECTOR	END 2 CONNECTOR	OVERALL LENGTH
RF180 = (4.52 mm) .178" overshield DIA, 16 AWG microwave cable	-06SP = N Type Straight Plug		-"XXXX" = Overall length in millimeters
RF280 = (7 mm) .277" overshield DIA, 11 AWG microwave cable	-06RP = N Type Right-angle Plug		-0152 (152 mm) 5.984" minimum (RF180)
	-06BJ = N Type Straight Bulkhead Jack		-0200 (200 mm) 7.87" minimum (RF280)

ALSO AVAILABLE

SMA, TNCA = RF180
SMA, TNCA = RF280

N Type Cable Connectors

PRF06



CONNECTORS FOR INDUSTRY STANDARD CABLES	
PRF06-P-C-EP-141A-SS	Harbour SS402
PRF06-J-C-EP-142-BS	Harbour LL142
PRF06-P-C-EP-142-SS	Harbour LL142
PRF06-P-C-EP-142-RS	Harbour LL142
PRF06-P-C-EP-142A-SS	Harbour SB142
PRF06-J-C-EP-335-BS	Harbour LL335
PRF06-P-C-EP-335-SS	Harbour LL335
PRF06-P-C-EP-335-RS	Harbour LL335
PRF06-P-C-EP-335A-SS	Harbour LL335i
PRF06-P-C-EP-335A-SS	Harbour LL335i
PRF06-P-C-EP-335A-RS	Harbour LL335i
PRF06-J-C-EP-160A-BS	Harbour LL160
PRF06-P-C-EP-160A-SS	Harbour LL160
PRF06-P-C-EP-160A-RS	Harbour LL160
PRF06-P-C-EP-120A-SS	Semflex HP120
PRF06-J-C-EP-190-BS	Semflex HP190
PRF06-P-C-EP-190-SS	Semflex HP190
PRF06-P-C-EP-190-RS	Semflex HP190
PRF06-J-C-EP-290-BS	Semflex LA290
PRF06-P-C-EP-290-SS	Semflex LA290
PRF06-P-C-EP-290-RS	Semflex LA290
PRF06-P-C-EP-305-SS	Semflex HP305
PRF06-J-C-EP-402-4S	RG 402, .141, semi-rigid
PRF06-P-C-EP-300A-SS	Times Max Gain 300
PRF06-P-C-EP-180B-SS	IW 1801
PRF06-P-C-EP-135-SS	Dynawave DF440W
PRF06-P-C-EP-270A-RS	Dynawave DF218
PRF06-P-C-EP-160B-SS	ATM CF-210
PRF06-P-C-EP 135B-SS	Lab-Flex 160S
PRF06-P-C-EP-284-SS	Micro-Coax UFB311A

For a complete list of N Type cable connectors, visit www.samtec.com?PRF06

INTERFACE STANDARD

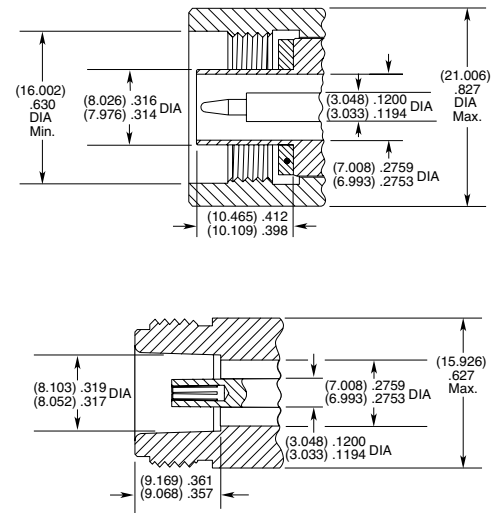

P-C = Cable Plug
J-C = Cable Jack
EP = Plating (50 μ" Gold center contact, passivated outer contact)
SS = Straight, Solder Clamp
RS = Right-angle, Solder Clamp
BS = Bulkhead, Solder Clamp
4S = 4-hole Flange, Solder Clamp

TNCA TO 18 GHz

TNCA Cable Assemblies

RF180, RF280

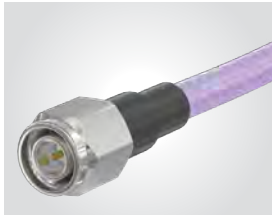

VSWR

RF180: 1.35 max. (-04SP & -04BJ)
1.45 max. (-04RP)
RF280: 1.35 max. (-04SP & -04BJ)

SERIES	END 1 CONNECTOR	END 2 CONNECTOR	OVERALL LENGTH
RF180 = (4.52 mm) .178" overshield DIA, 16 AWG microwave cable RF280 = (7 mm) .277" overshield DIA, 11 AWG microwave cable	-04SP = TNCA Straight Plug -04RP = TNCA Right-angle Plug (RF180 only) -04BJ = TNCA Straight Bulkhead Jack	-"XXXX" = Overall length in millimeters -0152 (152 mm) 5.984" minimum (RF180) -0200 (200 mm) 7.87" minimum (RF280)	

ALSO AVAILABLE

SMA, N Type = RF180
SMA, N Type = RF280

TNCA Cable Connectors

PRF04



CONNECTORS FOR INDUSTRY STANDARD CABLES	
PRF04-P-C-EP-142-RS	Harbour LL142
PRF04-J-C-EP-142-BS	Harbour LL142
PRF04-P-C-EP-142-SS	Harbour LL142
PRF04-P-C-EP-335-SS	Harbour LL335
PRF04-P-C-EP-290-SS	Semflex LA290
PRF04-J-C-EP-190-BS	Semflex HP190
PRF04-P-C-EP-190-RS	Semflex HP190
PRF04-P-C-EP-190-SS	Semflex HP190
PRF04-P-C-EP-335A-RS	Harbour LL335i
PRF04-J-C-EP-335A-BS	Harbour LL335i
PRF04-P-C-EP-300A-SS	Times Max Gain 300
PRF04-P-C-EP-200-SS	Times Max Gain 200
PRF04-P-C-EP-160A-SS	Harbour LL160
PRF04-J-C-EP-270A-BS	Dynawave DF218
PRF04-P-C-EP-135-SS	Dynawave DF440W
PRF04-P-C-EP-300A-SS	Times Max Gain 300
PRF04-J-C-EP-210A-BS	Micro-Coax UFA210A
PRF04-P-C-EP-210A-SS	Micro-Coax UFA210A
PRF04-P-C-EP-284-SS	Micro-Coax UFB311A
PRF04-J-C-EP-127-4S	Storm VSR150

For a complete list of TNCA cable connectors, visit www.samtec.com?PRF04

INTERFACE STANDARD

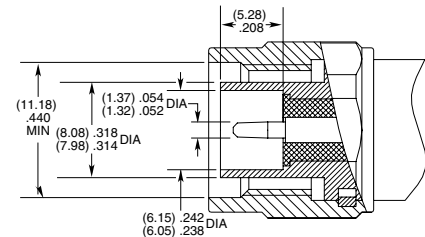
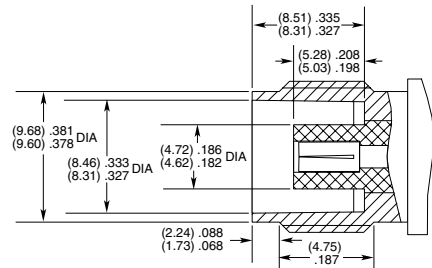

P-C = Cable Plug
J-C = Cable Jack
EP = Plating (50 μ" Gold center contact, passivated outer contact)
SS = Straight, Solder Clamp
RS = Right-angle, Solder Clamp
BS = Bulkhead, Solder Clamp
4S = 4-Hole Flange

IN-SERIES PRECISION RF ADAPTORS

1.85 mm, 2.40 mm, 2.92 mm In-Series Adaptors
PRFIA



VSWR

-185: 1.30 max.
-240: 1.20 max.
-292: 1.15 max.

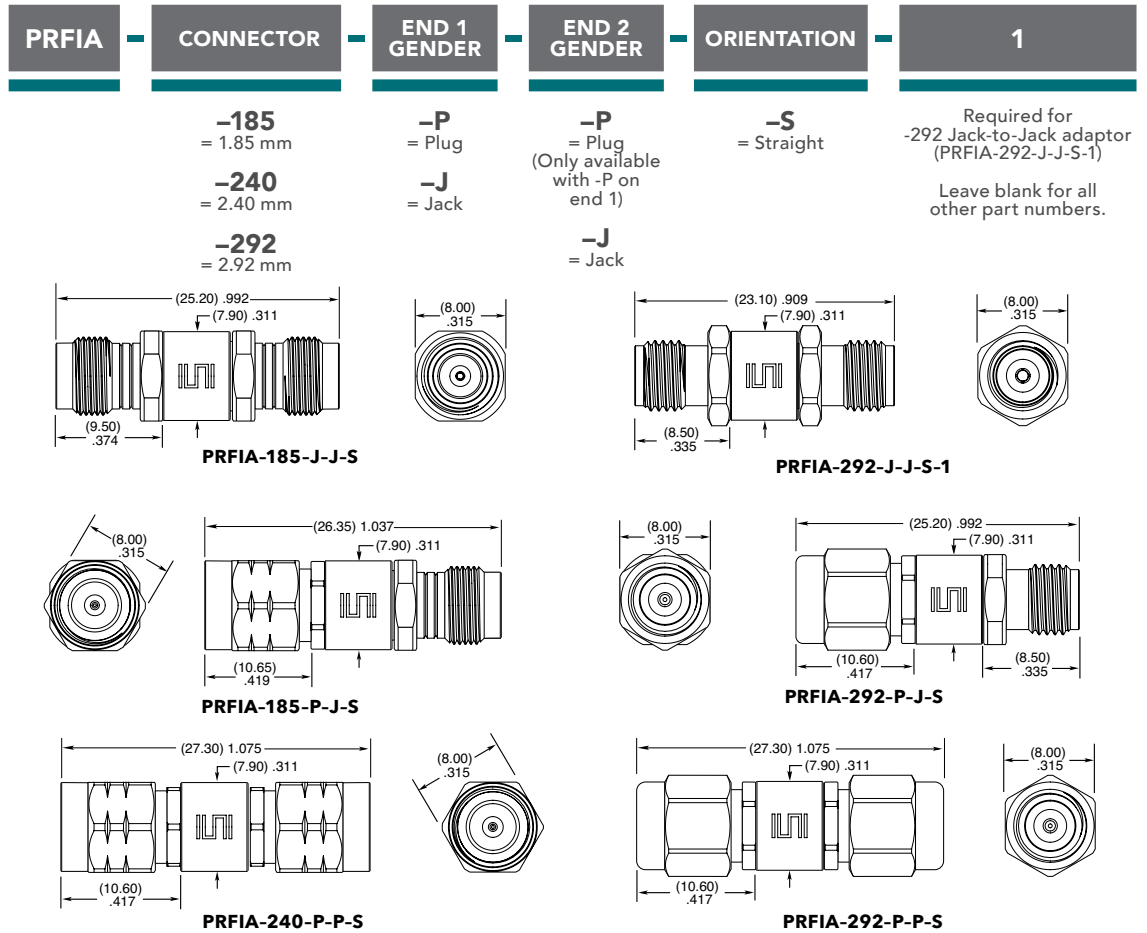

SMPM In-Series Adaptor:
PRFIA

Mates With:
SMPM, GPPB, GPPC



VSWR

1.15 max. (DC to 26.5 GHz)
1.35 max. (26.5 GHz to 40 GHz)
1.50 max. (40 GHz to 65 GHz)

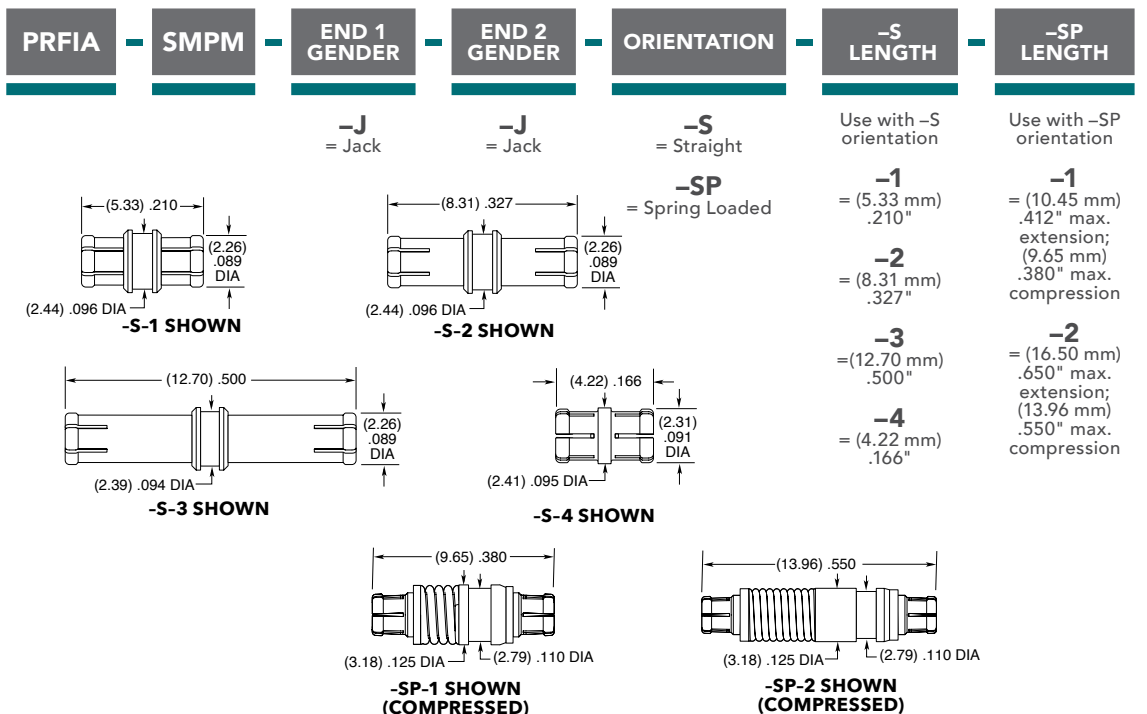

BETWEEN-SERIES PRECISION RF ADAPTORS

1.00 mm to 1.85 mm Adaptors

PRFBA



VSWR

1.12 max. (DC to 26.5 GHz)
 1.25 max. (26.5 GHz to 40 GHz)
 1.30 max. (40 GHz to 50 GHz)
 1.35 max. (50 GHz to 67 GHz)

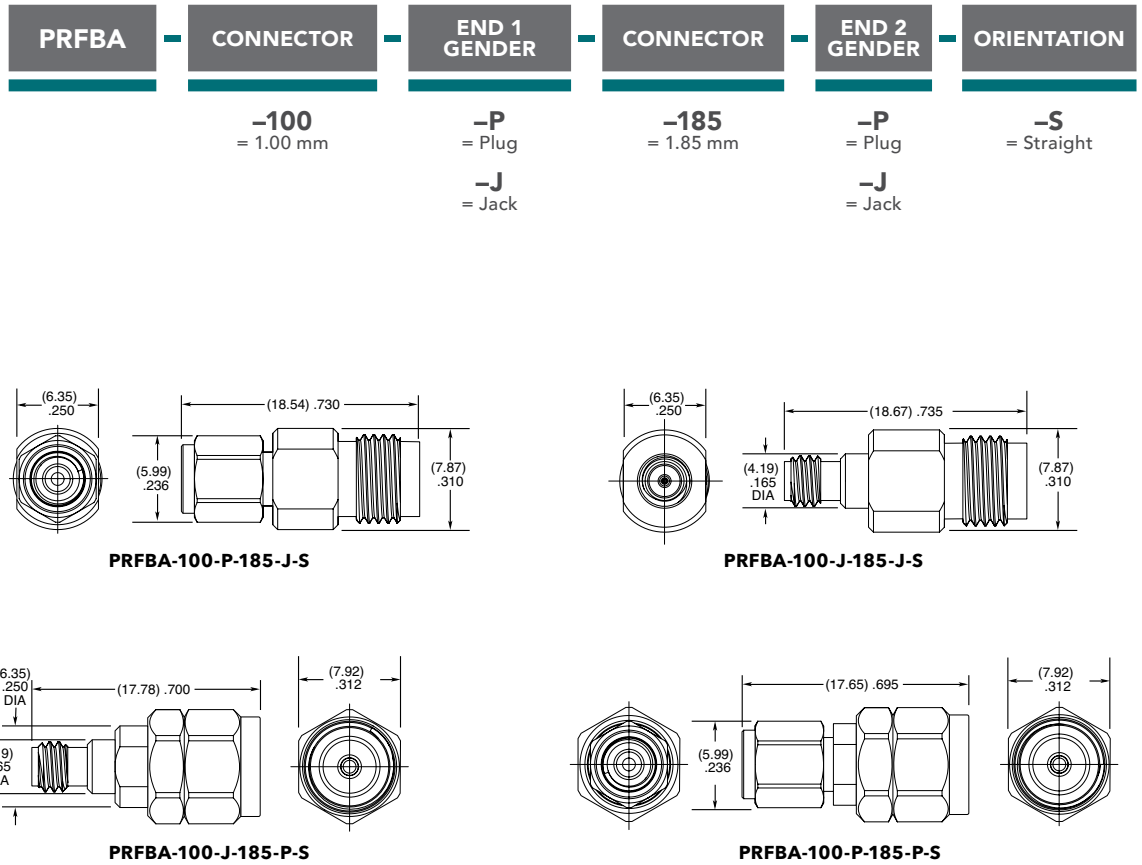

2.92 mm to SMPM Adaptors

PRFBA



VSWR

1.30 max. (DC to 40 GHz)

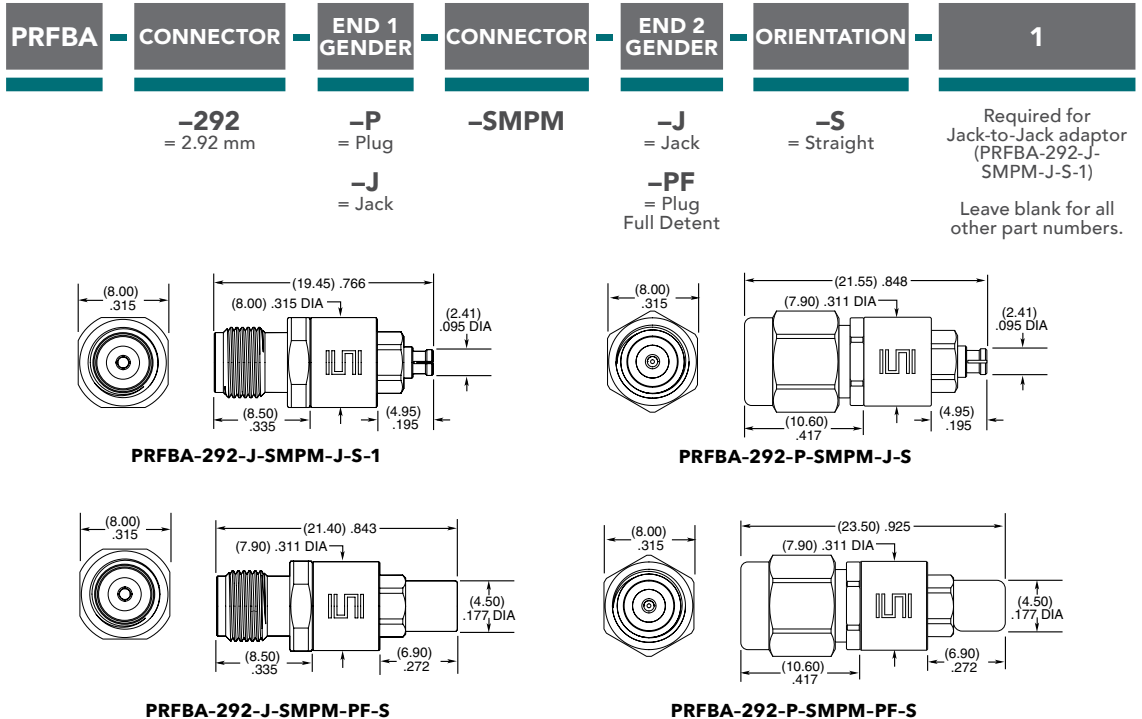

HIGH-PERFORMANCE TEST ASSEMBLIES TO 90 GHz

FEATURES & BENEFITS

The Bulls Eye® high-performance test assembly features a high-density, space-saving design that enables smaller evaluation boards and shorter trace lengths in test and measurement applications to 90 GHz.

- Compression mounts to the board for placement directly adjacent to the SerDes being characterized
- Solderless design improves cost and is easy to use within a lab setting
- End 2 connection to instrumentation: 1.00 mm, 1.35 mm, 1.85 mm, 2.40 mm or 2.92 mm
- High-density, space-saving design
- Single row or double row
- Complete list of applications: SerDes characterization, clock/data recovery (CDR), mmWave radar, automated test equipment, FR2 5G networks

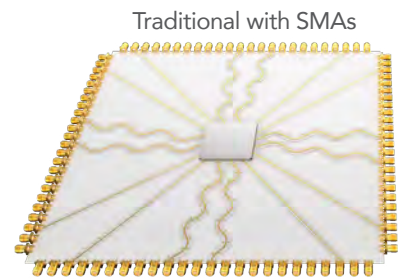

Bulls Eye®



DC TO	PAM 4
90 GHz	224 Gbps

HIGH-DENSITY & SPACE-SAVING

Enables smaller evaluation boards and shorter trace lengths.



PRODUCT FAMILY CROSS REFERENCE GUIDE

ASSEMBLY	90 GHz	70 GHz	50 GHz	40 GHz	TEST ASSEMBLY	SERDES CHARACTERIZATION		
Block Bottom View					BE90A, 90 GHz	<table border="1"> <tr><td>PAM 4</td></tr> <tr><td>224 Gbps</td></tr> </table>	PAM 4	224 Gbps
PAM 4								
224 Gbps								
End 2 Connector	1.00 & 1.35 mm	1.85 mm	2.40 mm	2.92 mm				
Samtec Series	BE90A	BE70A	BE40A					
Cable Type	.047	.086	MWC-2350CU-01		BE70A, 70 GHz	<table border="1"> <tr><td>PAM 4</td></tr> <tr><td>112 Gbps</td></tr> </table>	PAM 4	112 Gbps
PAM 4								
112 Gbps								
Cable Management	Yes							
PCB Transition	Microstrip/CPW or Stripline							
Bulls Eye® Connector Design	Spring-Loaded Contact; 360° Grounding		Pogo-Pin for Signal & Ground		BE40A, 50 GHz	<table border="1"> <tr><td>PAM 4</td></tr> <tr><td>56 Gbps</td></tr> </table>	PAM 4	56 Gbps
PAM 4								
56 Gbps								
No. of Rows	Single or Double		Double					
No. of Positions	1x: 2, 4, 8, 12 2x: 4, 8, 12, 16	1x: 2, 4, 8, 12 2x: 3, 4, 6, 8, 10, 12, 14, 16	2x: 3, 4, 6, 8, 10, 12, 14, 16					
Impedance	50 Ω				Xilinx® Zynq® UltraScale+™ RFSoc ZCU1275			
FPGA Development Kit	-							
SI Evaluation Kit	Contact RFgroup@samtec.com	70 GHz: REF-213864-01	50 GHz: REF-213497-01					

90 GHz ASSEMBLIES

BE90A	TRANSMISSION TYPE	END 2	PHASE MATCHING	ROW OPTION	POSITIONS PER ROW	OVERALL LENGTH
	-S = Stripline -M = Microstrip	-10BJ = 1.00 mm Straight Jack -10SP = 1.00 mm Straight Plug -13BJ = 1.35 mm Straight Jack -13SP = 1.35 mm Straight Plug	-1 = 1.0 Pico-second -2 = 2.0 Pico-seconds -5 = 5.0 Pico-seconds -N = No Phase Matching	-1 = Single Row (-02, -04, -08 & -12 positions only) -2 = Double Row (-04, -08, -12 & -16 positions only)	-02, -04, -08, -12, -16	-“XXXX” = Overall length in millimeters -0152 (152 mm) 5.984" minimum

BE90A

End 2 Connectors:
1.00 mm, 1.35 mm

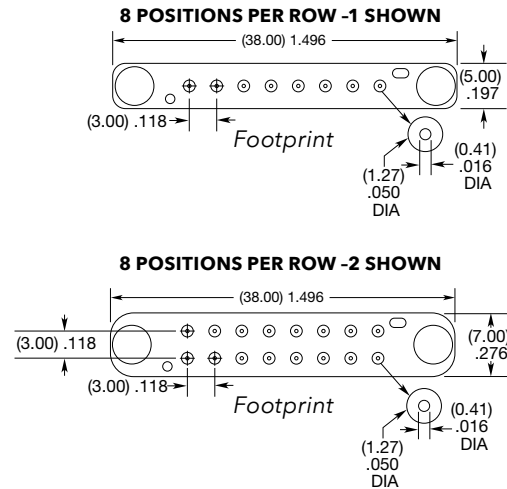

BE90A, 2 X 4 FOOTPRINT

Performance was measured using 50 Ohm coplanar waveguide (CPW) transmission line and 6 layer PCB (Isola Tachyon). The BE90A DUT consisted of a 2 row x 4 position -M (CPW/microstrip) block, 6-inch (152 mm) low-loss microwave cable and 1.00 mm end 2 connectors. Results include the breakout region and BE90A cable assembly. All other effects have been removed by de-embedding (AFR technique).

Insertion Loss Performance

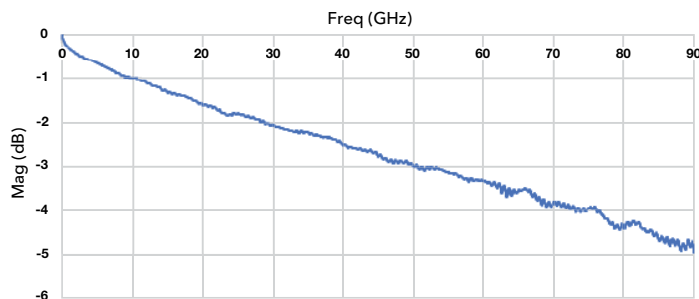

MEASURED: BREAKOUT REGION + BE90A

Return Loss Performance

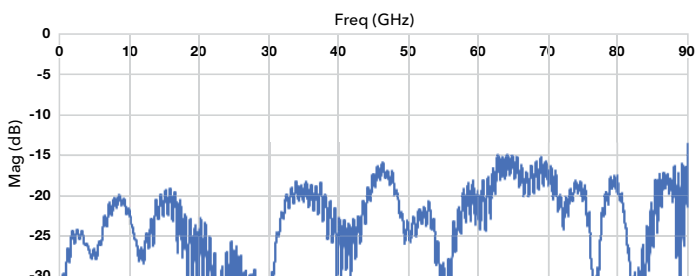

MEASURED: BREAKOUT REGION + BE90A

70 GHz ASSEMBLIES

BE70A	TRANSMISSION TYPE	END 2	PHASE MATCHING	ROW OPTION	POSITIONS PER ROW	OVERALL LENGTH
	-S = Stripline -M = Microstrip	-18SJ = 1.85 mm Straight Jack -18SP = 1.85 mm Straight Plug	-2 = 2.0 Pico-seconds -5 = 5.0 Pico-seconds -N = No Phase Matching	-1 = Single Row (-02, -04, -08 & -12 positions only) -2 = Double Row (-03 through -16 positions only)	-02, -03, -04, -06, -08, -10, -12, -14, -16	"XXXX" = Overall length in millimeters -0152 (152 mm) 5.984" minimum
DC TO	PAM 4					
70 GHz	112 Gbps					

BE70A
End 2 Connectors:
1.85 mm (70 GHz)

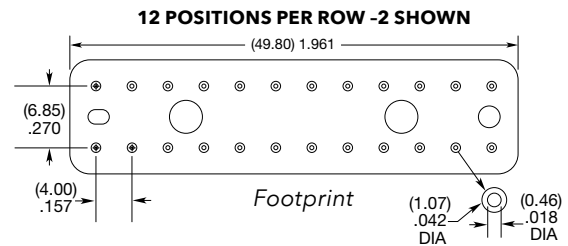
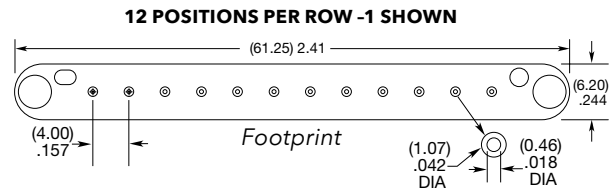

50 GHz & 40 GHz ASSEMBLIES

BE40A	TRANSMISSION TYPE	END 2	PHASE MATCHING	2	POSITIONS PER ROW	OVERALL LENGTH
	-S = Stripline -M = Microstrip	-92SJ = 40 GHz, 2.92 mm Straight Jack -24SJ = 50 GHz, 2.40 mm Straight Jack -92SP = 40 GHz, 2.92 mm Straight Plug -24SP = 50 GHz, 2.40 mm Straight Plug	-2 = 2.0 Pico-seconds -5 = 5.0 Pico-seconds -N = No Phase Matching		-03, -04, -06, -08, -10, -12, -14, -16	"XXXX" = Overall length in millimeters -0152 (152 mm) 5.984" minimum
DC TO	PAM 4					
50 GHz	56 Gbps					

BE40A
End 2 Connectors:
2.40 mm (50 GHz)
2.92 mm (40 GHz)

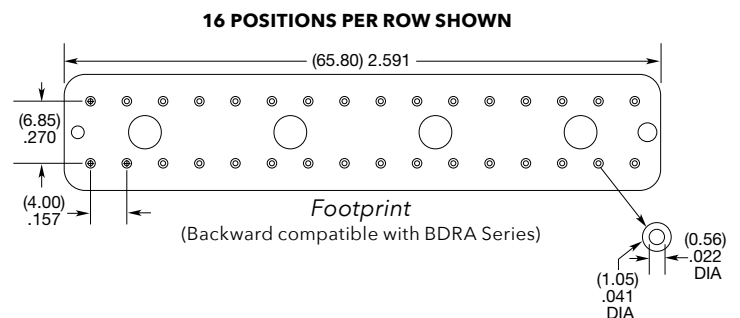

NEXT GENERATION FLEXIBLE WAVEGUIDE



HIGH FREQUENCY • FLEXIBLE CABLE • SMALL FORM FACTOR • LOW LOSS

Samtec's new, high frequency micro waveguide technology is designed to support the demands of next generation millimeter wave systems. It uses a cable design allowing flexibility and a reduced size, and supports frequencies up to 90 GHz (E-band), but with a loss performance greatly improved over coaxial cables.

Due to loss requirements, higher frequencies often require the use of rigid, metallic waveguides. However, Samtec's innovative technology provides an alternative solution that is flexible, easier to use, and lower cost, while also maintaining the near-loss performance of a traditional rigid waveguide.

LOSS COMPARISON

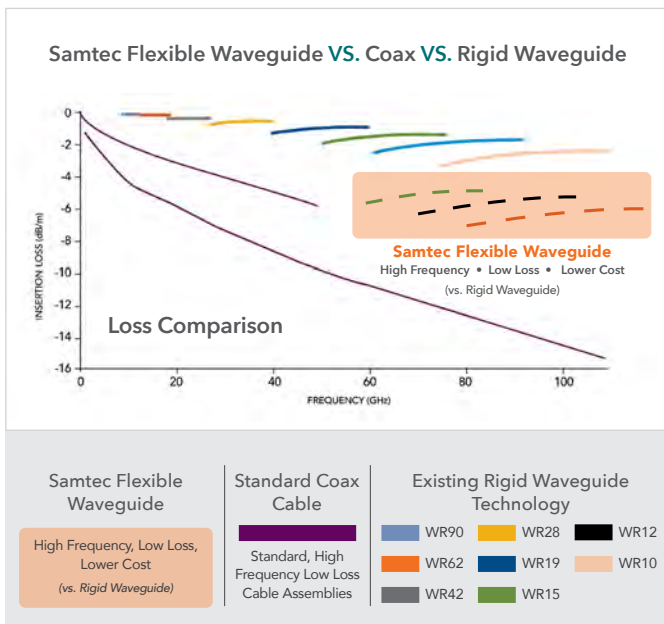

E-BAND, FLEXIBLE WAVEGUIDE

- 60 GHz to 90 GHz, E-band
- Low loss
- Flexible cable with dynamic stability
- Ultra-small form factor

PRODUCT	SERIES	FREQUENCY BAND	DIMENSIONS
Waveguide	WF12	E (60 to 90 GHz)	Overall Length: 102 mm (4.00") Min.
	WGBA		Threaded Plug: 5 mm (.196") x 8 mm (.314")
Adaptor	WGBA		Diameter: 19.05 mm (.750") (mates with WR12 standard flange)

V-Band (50 to 75 GHz)
WF15 Series Flexible Waveguide
Cross Section: 3.76 mm (.148") x 1.88 mm (.074") nom.
UG-385 flange adaptor to Threaded Waveguide Jack

FLEXIBILITY & STABILITY

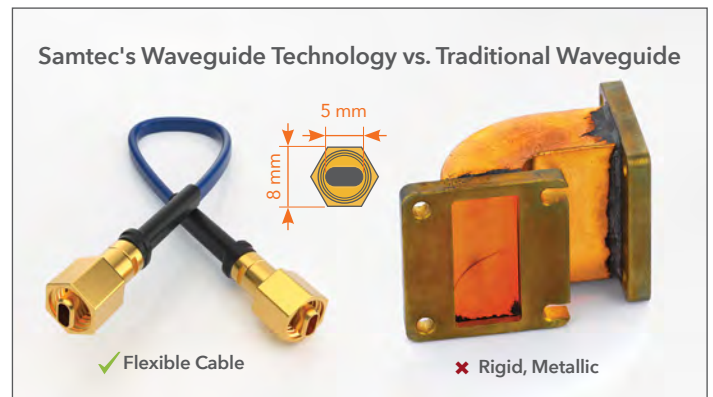
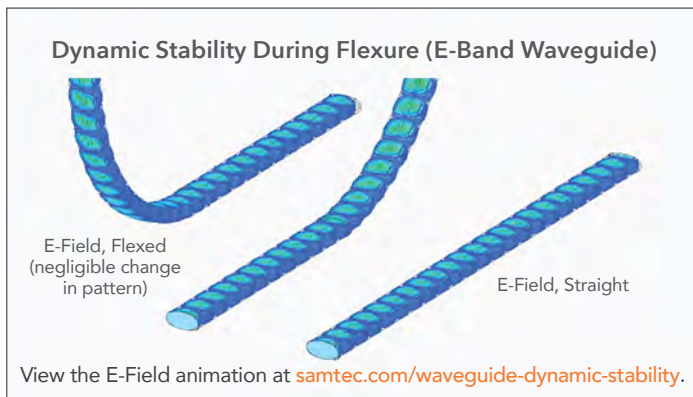

View complete specifications at: samtec.com?WF12 and samtec.com?WGBA

LOW FREQUENCY CABLE SPECIFICATIONS

STANDARD OFF-THE-SHELF ASSEMBLIES

SERIES	MH081	MH113	RF178	RF174	IJ5C [†] (IsoRate [®])	RF316, IJ5C, IJ5H, GRF1-C, GRF1H-C	RS316	RF058	RF179, GRF7-C, GRF7H-C	RFB8T	RFC8T	RFB6T	RFC6T	RFA6T	C28S		
TYPE	50 Ω CABLES								75 Ω CABLES						100 Ω CABLES		
	0.81 mm (34 AWG)	1.13 mm (31 AWG)	RG 178 (28 AWG)	RG 174 (24 AWG)	Samtec 26 AWG, high-temp micro coax	RG 316 (24 AWG)	RG 316, double shielded (24 AWG)	RG 58 (20 AWG)	RG 179 (28 AWG)	Belden 1855A (23 AWG)	12G-SDI, Belden 4855R (23 AWG)	Belden 1694A (18 AWG)	12G- SDI, Belden 4694R (18 AWG)	RG 6 (18 AWG)	Samtec 28 AWG, shielded twisted pair		
ELECTRICAL																	
Impedance	Ω	50 ± 3	50 ± 2	50 ± 5	50 ± 2	50 ± 3	75 ± 3						100 ± 5				
Insertion Loss (dB/m)	100 MHz	1.00	0.60	0.50	0.40	0.68	0.30	1.40 @ 2 GHz	0.20	0.30	0.12		0.07	0.06	0.07	-----	
	1 GHz	3.10	1.90	1.70	1.40	2.37	1.25	1.60 @ 3 GHz	0.80	0.80	0.37	0.36	0.21	0.19	0.21	-----	
	6 GHz	8.60	4.90	5.90	4.40	6.53	4.25	2.20 @ 5 GHz	5.40	3.60	0.97	0.91	0.59	0.51	0.59	-----	
Propagation Delay	nS/m	4.70	4.70	4.83	5.06	4.17	4.83	-----	5.05	4.83	4.12		4.06		3.92	4.03	-----
Current Rating	Amps	1.20	2.10	3.00	5.00	3.00	5.00	-----	-----	3.00	5.00	4.70	-----	16.00	-----		
Capacitance	pF/m	100.00	95.00	96.00	101.00	85.60	96.00	95.80	102.00	64.00	55.70	53.40	53.14	52.20	53.14	38.00	
CONSTRUCTION																	
Center Conductor	Material	Silver Plated Copper		Silver Plated Copper Clad Steel	Bare Copper	Silver Plated Copper	Silver and Copper Plated Steel	Silver Plated Copper Clad Steel	Tinned Copper	Silver Plated Copper	Bare Copper	Silver Plated Copper	Bare Copper	Silver Plated Copper	Bare Copper	Silver Plated Copper	
	AWG	34	31	28	24	26	24		20	28	23		18		28		
Dielectric	Material	FEP		PTFE	KLPE	Foamed FEP	PTFE	FEP	Solid Polyethylene	PTFE	FHDPE	PE (Foam)	FHDPE	PE (Foam)	FHDPE	FEP	
Shield	Material	Silver Plated Copper	Tinned Copper	Silver Plated Copper	Tinned Copper	Silver Plated Copper			Tinned Copper	Silver Plated Copper	1. Al Foil-Polyester Tape-Al Foil 2. Tinned Copper		1. Bonded Al Foil 2. Al Wire		1. Al Foil-Polyester Tape-Al Foil 2. Tinned Copper		Silver Plated Copper
Jacket	Material	PFA	FEP		PVC	FEP			PVC	FEP	PVC						
MECHANICAL																	
Operating Temp		-40 °C to +90 °C		-50 °C to +165 °C	-20 °C to +80 °C	-40 °C to +200 °C	-55 °C to +165 °C		-50 °C to +90 °C	-50 °C to +165 °C	-30 °C to +75 °C		-20 °C to +75 °C	-30 °C to +75 °C	-20 °C to +105 °C		
Bend Radius	Min	5.00 mm	6.80 mm	10.20 mm	25.40 mm	3.18 mm	12.80 mm	12.80 mm	49.50 mm	10.20 mm	38.10 mm	41.00 mm	69.85 mm	70.00 mm	69.85 mm	19.05 mm	
Connector Options		MHF1, MHF3, MHF4	MHF1, SMA	MMCX, MCX, SMA, SMB, BNC, TNC, N Type	MMCX, MMCXV, MCX, SMA, SMB, BNC, TNC, N Type, Ganged	IsoRate [®]	MMCX, MMCXV, MCX, SMA, SMB, BNC, TNC, N Type, Ganged	MMCX, MCX, SMA, SMB, BNC, TNC	SMA, TNC, N Type	MCX, MMCX7, SMB, BNC, DIN 1.0/2.3, Ganged	HD-BNC, DIN 1.0/2.3		BNC, HD-BNC, DIN 1.0/2.3		CJT		

[†] ALSO USES RG 316

50 Ω MICRO HIGH FREQUENCY RF CABLES TO 6 GHz

MHF Cable Assemblies MH081, MH113



SPECIFICATIONS

Outer Contact Material:
Au plated Phosphor Bronze
Center Contact Material:
Au plated Phosphor Bronze (MHX)
Au plated BeCu (SMA)
Insulator Material:
PBT (MHX)
PTFE (SMA)
Operating Temperature:
-40 °C to +90 °C
Voltage Rating:
170 V max
Dielectric Withstanding Voltage:
200 Vrms

0.81 mm Cable:

Capacitance:
100 pF/meter
Max Attenuation (cable only):
3.1 dB @ 1 GHz
Conductor Size:
36 AWG, (0.81 mm) .032" dia.
Conductor Material:
Silver Plated Copper
Conductor Resistance:
1.40 Ω/meter max
Insulator Diameter:
(0.4 mm) .016"
Insulator Material: FEP
Shield Material:
Silver Plated Copper
Jacket Material: PFA
Jacket Diameter:
(0.81 mm) .032" dia.
Bend Radius: 5.0 mm
Jacket Temp Rating:
-40 °C to +90 °C

1.13 mm Cable:

Capacitance:
95 pF/meter
Max Attenuation (cable only):
2 dB @ 1 GHz
Conductor Size:
32 AWG, (1.13 mm) .045" dia.
Conductor Material:
Silver Plated Copper
Conductor Resistance:
0.60 Ω/meter max
Insulator Diameter:
(0.66 mm) .026"
Insulator Material:
FEP
Shield Material:
Tinned Copper
Jacket Material:
FEP
Jacket Diameter:
(1.13 mm) .045" dia
Bend Radius:
6.8 mm
Jacket Temp Rating:
-40 °C to +90 °C

SERIES	END 1 CONNECTOR	END 2 CONNECTOR	OVERALL LENGTH
--------	-----------------	-----------------	----------------

MH081
= 0.81 mm Cable
MH113
= 1.13 mm Cable

Specify END OPTIONS from chart

-0030
= 1.18" (30 mm)
-0050
= 1.97" (50 mm)
-0100
= 3.94" (100 mm)
-0150
= 5.91" (150 mm)
-0300
= 11.81" (300 mm)

APPLICATION

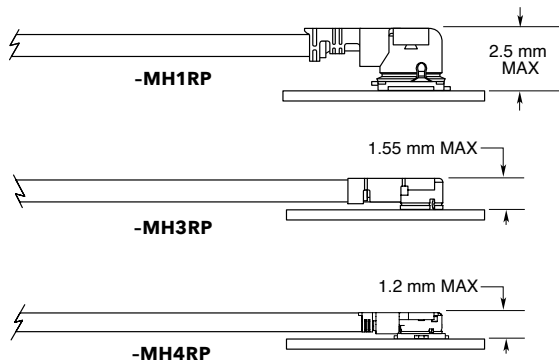

EXTRACTION TOOLS

MH1RP = RSP-122893-01
MH3RP = RSP-122893-02
MH4RP = RSP-122893-03

MATING SOLUTIONS

MH1RP end mates with RSP-122811-01 (Cycles: 30 max.)

MH3RP end mates with RSP-122811-02

MH4RP end mates with RSP-122811-03



END OPTIONS

-MH1RP = MHF1 Type Plug (3.9 μ" (0.1 μm) Gold on Center Contact, 1.9 μ" (0.05 μm) Gold on Shell)	
-MH3RP = MHF3 Type Plug (3.9 μ" (0.1 μm) Gold on Center Contact, 1.9 μ" (0.05 μm) Gold on Shell) (MH081 only)	
-MH4RP = MHF4 Type Plug (10 μ" (0.25 μm) Gold on Center Contact, 1.9 μ" (0.05 μm) Gold on Shell) (MH4RP is not available with MH1RP & MH3RP) (MH081 only)	
-01BJ1 = SMA Straight Bulkhead Jack (MH081 only) -01BJ2 = SMA Straight Bulkhead Jack, Reversed Polarity -01SB1 = SMA Straight Jack, Sealed Bulkhead -01SR1 = SMA Straight Jack, Sealed Bulkhead, Reversed Polarity (30 μ" (0.76 μm) Gold on Center Contact, Gold Flash on Shell)	
-SING = Single Ended (End 2 callout)	
XXXXXX = Stripped & Tinned (End 2 callout)	

STRIPPED & TINNED (Dimensions in mm)

CALLOUT	A	B	C
-303030	3.0	3.0	3.0
-303040	3.0	3.0	4.0
-403030	4.0	3.0	3.0
-403040	4.0	3.0	4.0
-404040	4.0	4.0	4.0

Both center conductor and braid shield are stripped, only the center conductor is tinned.

50 Ω SMA TO 6 GHz

SMA Cable Assemblies

RF174, RF178, RF316, RS316, RF058



SERIES	END 1 CONNECTOR	END 2 CONNECTOR	OVERALL LENGTH
RF174 = RG 174 Cable	-01SP1 = SMA Straight Plug		-"XXXX" = Overall Length in millimeters
RF178 = RG 178 Cable (-01BJ1 & -01BR1 only)	-01RP1 = SMA Right-angle Plug		-0100 (100 mm) 3.94" minimum
RF316 = RG 316 Cable, Single Braid Shield	-01BJ1 = SMA Straight Bulkhead Jack		
RS316 = RG 316 Cable, Double Shield (-01SP1 & -01BJ1 only)	-01SB1 = Straight Bulkhead Jack, Sealed		
RF058 = RG 58 Cable (-01SP1, -01BJ1 & -01SB1 only)	-01SR1 = Straight Bulkhead Jack, Sealed, Reversed Polarity		
	-01BR1 = Straight Bulkhead Jack, Reversed Polarity		
	-01PN1 = 4-Hole Panel Mount Jack		

ALSO AVAILABLE

50 Ω: MCX, MMCX, SMB, BNC, TNC,
N Type = RF174, RF178, RF316

50 Ω: MCX, MMCX, BNC, TNC = RS316

50 Ω: TNC = RF058

SMA Cable Connectors

SMA-CA



Supplied with pins, washers, nuts and ferrules. See website for dimensions.

SMA	GENDER	TYPE	PLATING	ORIENTATION	TERMINATION	PACKAGING
	-J = Jack	-C = Cable	-H = 30 μ" (0.76 μm) Gold center contact, 3 μ" (0.08 μm) Gold outer contact (N/A with -BH1S)	-ST = Straight	-BH1 = Bulkhead RG 174 / 316 Cable	Leave blank for individually bagged.
		-C4 = Cable 4-Mounting Screws (-PN1 only)	-HF = 30 μ" (0.76 μm) Gold center contact, 3 μ" (0.08 μm) Gold outer contact (-BH1S only)		-BH2 = Bulkhead RG 178 Cable	-B = Bulk packaged (-BH1 only)
					-BR1 = Bulkhead RG 174 / 316, Reversed Polarity	-B10 = Bulkhead RG 58 Cable
					-BR2 = Bulkhead RG 178 Cable, Reversed Polarity	-PN1 = 4-Hole Panel Mount RG 174 / 316 Cable
					-S10 = Sealed Bulkhead RG 58 Cable	

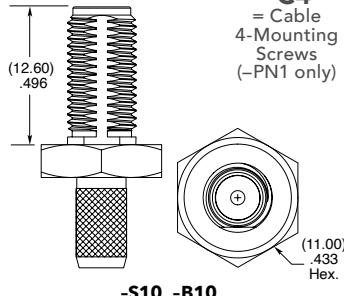

SMA Board Connectors

See page 18 for Board Connectors

SMA	GENDER	TYPE	PLATING	ORIENTATION	TERMINATION	PACKAGING
	-P = Plug	-C = Cable	-H = 30 μ" (0.76 μm) Gold center contact, 3 μ" (0.08 μm) Gold outer contact (-CA1, -C10 only)	-ST = Straight	-CA1 = RG 174 / 316 Cable	Leave blank for individually bagged.
			-HF = 30 μ" (0.76 μm) Gold center contact, 3 μ" (0.08 μm) Gold outer contact (-CA1S only)	-RA = Right-angle	-C10 = RG 58 Cable (-ST only)	-B = Bulk packaged (-CA1 only)
					-CA1S = RG 316 Double Shielded Cable (-ST only)	

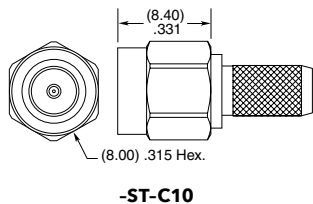

Supplied with pins, washers, nuts and ferrules. See website for dimensions.

50 Ω MCX TO 6 GHz

MCX Cable Assemblies

RF174, RF178, RF316, RS316



SERIES	END 1 CONNECTOR	END 2 CONNECTOR	OVERALL LENGTH
RF174 = RG 174 Cable	-02SJ1 = MCX Straight Jack		-“XXXX” = Overall Length in millimeters
RF178 = RG 178 Cable	-02RP1 = MCX Right-angle Plug (RS316 not available)		-0100 (100 mm) 3.94" minimum
RF316 = RG 316 Cable, Single Braid Shield	-02SP1 = MCX Straight Plug		
RS316 = RG 316 Cable, Double Shielded			

ALSO AVAILABLE

50 Ω: MMCX, SMA, SMB, BNC, TNC,
N Type = RF174, RF178, RF316
50 Ω: MMCX, SMA, BNC, TNC = RS316

MCX Board Connectors

MCX-TH, MCX-SM, MCX-EM, MCX-MT

Cable Mates:

RF174, RF178, RF316, RS316, GRF1H-C, IJ5H

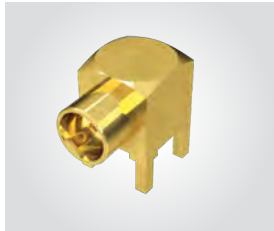

MCX	GENDER	TYPE	PLATING	ORIENTATION	TERMINATION
	-J = Jack	-P = PCB Mount	-H = 30 μ" (0.76 μm) Gold center contact, 3 μ" (0.08 μm) Gold outer contact	-ST = Straight -RA = Right-angle	-TH1 = Through-hole (-ST plug not available) -TH2 = Elevated Through-hole (-ST plug only) -SM1 = Surface Mount (Jack only) -EM1 = Edge Mount (-ST jack only) -MT1 = Mixed Technology (-ST jack only)

-ST-SM1 (Jack)

-RA-TH1 (Plug)

MCX Cable Connectors

MCX-CA



CONNECTORS FOR INDUSTRY STANDARD CABLES	
MCX-J-C-H-ST-CA1	RG 174/316 Cable
*MCX-J-C-H-ST-CA2	RG 178 Cable
MCX-J-C-HF-ST-CA1S	RG 316 Double Shielded Cable
*MCX-P-C-H-ST-CA1	RG 174/316 Cable
MCX-P-C-H-ST-CA2	RG 178 Cable
MCX-P-C-HF-ST-CA1S	RG 316 Double Shielded Cable
*MCX-P-C-H-RA-CA1	RG 174/316 Cable
MCX-P-C-H-RA-CA2	RG 178 Cable

P-C = Cable Plug
J-C = Cable Jack
H or HF = Plating (30 μ" Gold center contact, 3 μ" Gold outer contact)
ST = Straight
RA = Right-angle

*Add "-B" to the end of the part number for bulk packaging

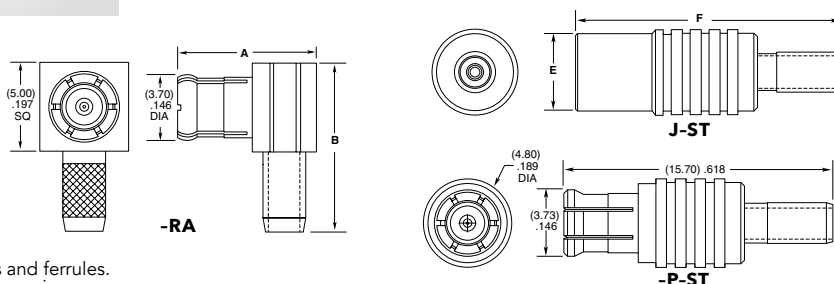

Supplied with pins and ferrules. See website for dimensions.

TYPE (-RA)	A	B
-P-CA1	(7.78) .306	(9.50) .374
-P-CA2	(8.58) .338	(10.00) .394

TYPE (-ST)	E	F
-J-CA1	(4.50) .177	(15.50) .610
-J-CA2	(4.78) .188	(15.00) .591
-J-CA1S	(4.50) .177	(15.50) .610

50 Ω MMCX TO 6 GHz

MMCX Cable Assemblies

RF174, RF178, RF316, RS316

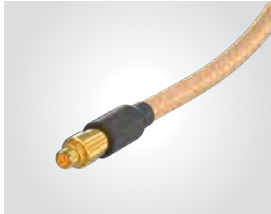

SERIES	END 1 CONNECTOR	END 2 CONNECTOR	OVERALL LENGTH
RF174 = RG 174 Cable	-03SP1 = MMCX Straight Plug		-“XXXX” = Overall Length in millimeters -0100 (100 mm) 3.94" minimum
RF178 = RG 178 Cable (-03SP1 & -03RP1 only)	-03RP1 = MMCX Right-angle Plug		
RF316 = RG 316 Cable, Single Braid Shield	-V3SP1 = MMCXV Straight Plug, High Vibration		
RS316 = RG 316 Cable, Double Shielded (-03SP1 only)	-V3RP1 = MMCXV Right-angle Plug, High Vibration		
		-V3SJ1 = MMCXV Straight Jack, High Vibration	

ALSO AVAILABLE

50 Ω: MCX, SMA, SMB, BNC, TNC,
N Type = RF174, RF178, RF316

50 Ω: MCX, SMA, BNC, TNC = RS316

MMCX Board Connectors

MMCX-SM, MMCX-TH, MMCX-MT, MMCX-EM

Cable Mates:
RF174, RF178, RF316, RS316,
GRF1H-C, IJ5H



MMCX	GENDER	TYPE	PLATING	ORIENTATION	TERMINATION
	-J = Jack	-P = PCB Mount	-H = 30 μ" (0.76 μm) Gold center contact, 3 μ" (0.08 μm) Gold outer contact	-ST = Straight -RA = Right-angle	-TH1 = Through-hole -MT1 = Mixed Technology (-ST only) -SM1 = Surface Mount (-RA plug not available) -EM1 = Edge Mount (-ST only)

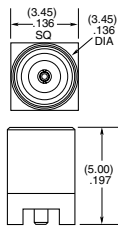

-ST-SM1 (Jack)

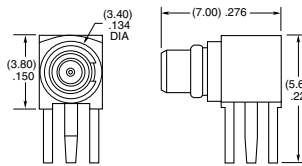

-RA-TH1 (Plug)

MMCX Cable Connectors

MMCX-CA



CONNECTORS FOR INDUSTRY STANDARD CABLES	
MMCX-P-C-H-ST-CA1	RG 174/316 Cable
MMCX-P-C-H-ST-CA2	RG 178 Cable
MMCX-P-C-HF-ST-CA1S	RG 316 Double Shielded Cable
MMCX-P-C-H-RA-CA1	RG 174/316 Cable
MMCX-P-C-H-RA-CA2	RG 178 Cable

Add "-B" to the end of the part number for bulk packaging

P-C = Cable Plug

H or HF = Plating (30 μ" Gold center contact,
3 μ" Gold outer contact)

ST = Straight

RA = Right-angle

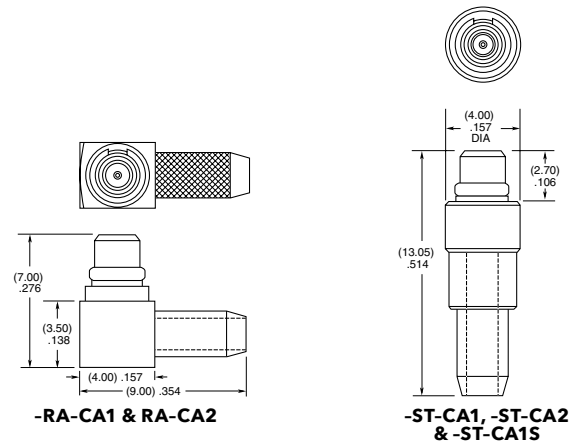

-RA-CA1 & RA-CA2

-ST-CA1, -ST-CA2 & -ST-CA1S

Supplied with pins and ferrules.
See website for dimensions.

50 Ω TNC TO 6 GHz

TNC Cable Assemblies

RF174, RF178, RF316, RS316, RF058

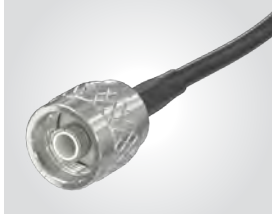

SERIES	END 1 CONNECTOR	END 2 CONNECTOR	OVERALL LENGTH
RF174 = RG 174 Cable	-05SP3 = TNC Straight Plug (RF058 not available)	-05BJ3 = TNC Straight Bulkhead Jack (RS316 & RF058 not available)	-“XXXX” = Overall Length in millimeters -0100 (100 mm) 3.94" minimum
RF178 = RG 178 Cable			
RF316 = RG 316 Cable, Single Braid Shield			
RS316 = RG 316 Cable, Double Shielded			
RF058 = RG 58 Cable			

ALSO AVAILABLE

50 Ω: MCX, MMCX, SMA, SMB, BNC,
N Type = RF174, RF178, RF316

50 Ω: MCX, MMCX, SMA, BNC = RS316

50 Ω: SMA, N Type = RF058

TNC Board Connectors

TNC-TH

Cable Mates:

RF174, RF178, RF316, RS316, RF058, GRF1H-C

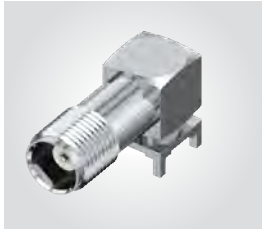

TNC	GENDER	TYPE	PLATING	ORIENTATION	TERMINATION
	-J = Jack	-P = PCB Mount	-H = 30 μ" (0.76 μm) Gold center contact, Nickel on shell	-RA = Right-angle	-TH1 = Through-hole

TNC Cable Connectors

TNC-CA



CONNECTORS FOR INDUSTRY STANDARD CABLES	
TNC-P-C-GN-ST-CA1	RG 174/316 Cable
TNC-P-C-GN-ST-CA2	RG 178 Cable
TNC-P-C-GN-SR-C10	RG 58 Cable
TNC-J-C-GN-ST-BH1	RG 174/316 Cable, Bulkhead
TNC-J-C-GN-ST-BH2	RG 178 Cable, Bulkhead

P-C = Cable Plug
J-C = Cable Jack
GN = Plating (10 μ" Gold on contact, Nickel on body)
ST = Straight
SR = Straight Reverse Polarity

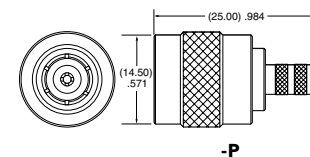
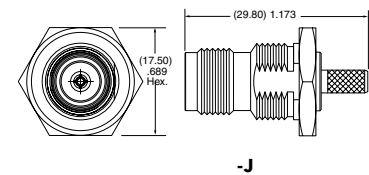

Supplied with pins, washers, nuts and ferrules. See website for dimensions.

50 Ω BNC TO 4 GHz

BNC Cable Assemblies

RF174, RF178, RF316, RS316



SERIES	END 1 CONNECTOR	END 2 CONNECTOR	OVERALL LENGTH
RF174 = RG 174 Cable	-04SP3 = BNC Straight Plug (RS316 not available)	-04BJ2 = BNC Bulkhead Jack	-"XXXX" = Overall Length in millimeters -0100 (100 mm) 3.94" minimum
RF178 = RG 178 Cable			
RF316 = RG 316 Cable, Single Braid Shield			
RS316 = RG 316 Cable, Double Shielded			
ALSO AVAILABLE			
50 Ω: MCX, MMCX, SMA, SMB, TNC, N Type = RF174, RF178, RF316			
50 Ω: MCX, MMCX, SMA, TNC = RS316			

BNC Cable Connectors

BNC5-CA



Supplied with pins, washers, nuts, gaskets and ferrules. See website for dimensions.

CONNECTORS FOR INDUSTRY STANDARD CABLES	
*BNC5-P-C-GN-ST-CA1	RG 174/316 Cable
*BNC5-P-C-GN-ST-CA2	RG 178 Cable
*BNC5-J-C-GN-ST-BH1	RG 174/316 Cable, Bulkhead
BNC5-J-C-GN-ST-BH2	RG 178 Cable, Bulkhead
BNC5-J-C-GN-ST-BH1S	RG 316 Double Shielded Cable, Bulkhead

*Add "-B" to the end of the part number for bulk packaging

P-C = Cable Plug

J-C = Cable Jack

GN = Plating (10 μ" Gold on contact, Nickel on body)

ST = Straight

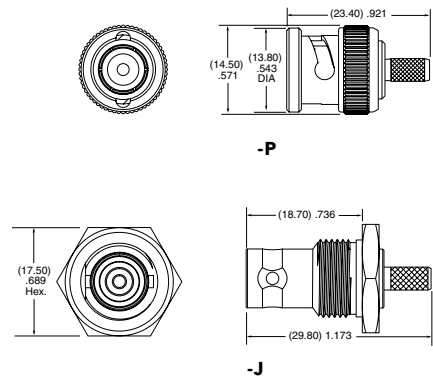

50 Ω SMB TO 4 GHz

SMB Cable Assemblies

RF174, RF178, RF316



SERIES	END 1 CONNECTOR	END 2 CONNECTOR	OVERALL LENGTH
RF174 = RG 174 Cable	-07SP1 = SMB Straight Plug		-“XXXX” = Overall Length in millimeters
RF178 = RG 178 Cable	-07RP1 = SMB Right-angle Plug		-0100 (100 mm) 3.94" minimum
RF316 = RG 316 Cable, Single Braid Shield	-07BJ1 = SMB Bulkhead Jack		
	-07BJ2 = SMB Bulkhead Jack (RF178 only)		

ALSO AVAILABLE

50 Ω: MCX, MMCX, SMA, BNC, TNC,
N Type = RF174, RF178, RF316

SMB Board Connectors

SMB5-TH

Cable Mates:
RF174, RF178, RF316,
GRF1H-C, IJ5H

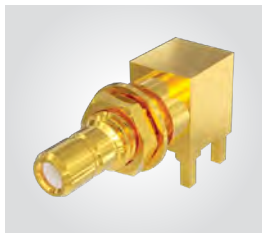

SMB5	GENDER	TYPE	PLATING	ORIENTATION	TERMINATION
	-J = Jack	-P = PCB Mount	-H = 30 μ" (0.76 μm) Gold center contact, 3 μ" (0.08 μm) Gold outer contact	-RA = Right-angle	-TH1 = Through-hole

SMB Cable Connectors

SMB5-CA



CONNECTORS FOR INDUSTRY STANDARD CABLES	
SMB5-P-C-H-ST-CA1	RG 174/316 Cable
SMB5-P-C-H-RA-CA1	RG 174/316 Cable
SMB5-J-C-H-ST-CA2	RG 178 Cable
SMB5-J-C-H-ST-BH1	RG 316 Cable, Bulkhead

P-C = Cable Plug
J-C = Cable Jack
H = Plating (30 μ" Gold center contact, 3 μ" Gold on outer contact)
ST = Straight
RA = Right-angle

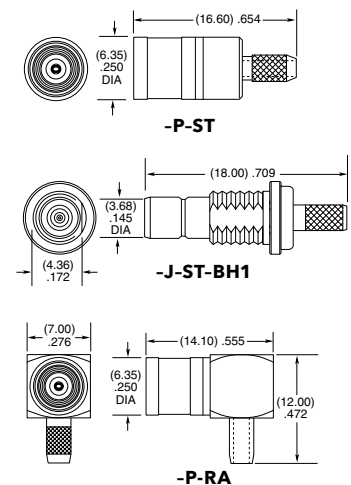

Supplied with pins, washers, nuts and ferrules. See website for dimensions.



75 Ω BNC TO 12 GHz

BNC Cable Assemblies

RFC6T, RFA6T, RFB6T, RF179



SERIES	END 1 CONNECTOR	END 2 CONNECTOR	OVERALL LENGTH
RFC6T* = 12G-SDI, Belden 4694R Cable	-74SP3 = 75 Ω BNC Straight Plug		-“XXXX” = Overall Length in millimeters -0300 (300 mm) 11.81" minimum (RFA6T, RFB6T, RFC6T) -0100 (100 mm) 3.94" minimum (RF179)
RFA6T = RG 6 Cable	-D4SP3 = 75 Ω BNC Die Cast Straight Plug (RFA6T, RFB6T, RF179 only)		
RFB6T = Belden 1694A Cable	-74BJ3 = 75 Ω BNC Bulkhead Jack (RF179 only)		
RF179 = RG 179 Cable	-74RP3 = 75 Ω BNC Right-angle Plug (RFA6T, RFB6T, RFC6T only)		

ALSO AVAILABLE

75 Ω: DIN 1.0/2.3, HDBNC = RFA6T, RFB6T, RFC6T

75 Ω: DIN 1.0/2.3, SMB, MCX, MMCX = RF179

*Designed to meet SMPTE 2082 12G-SDI specifications.

BNC Cable Connectors

BNC7T-CA



Supplied with pins, washers, nuts, gaskets and ferrules. See website for dimensions.

CONNECTORS FOR INDUSTRY STANDARD CABLES	
**BNC7T-P-C-GN-ST-CA3	Machined, RG 179 Cable
**BNC7T-P-C-GN-RA-CA3	Machined, RG 179 Cable
**BNC7T-P-C-GN-ST-CA6	*Machined, RG 6 Cable
**BNC7T-P-C-GN-RA-CA6	*Machined, RG 6 Cable
**BNC7T-P-C-GN-ST-CA6B	Belden 4694R Cable
**BNC7T-P-C-GN-RA-CA6B	Belden 4694R Cable
**BNC7T-J-C-GN-ST-BH3	Machined, Bulkhead, RG 179 Cable
BNC7T-P-C-GN-ST-CA3D	Die Cast, RG 179 Cable
BNC7T-P-C-GN-ST-CA6D	Die Cast, RG 179 Cable

P-C = Cable Plug
J-C = Cable Jack
GN = Plating (10 μ" Gold on contact, Nickel on outer contact and shell)
ST = Straight
RA = Right-angle

**Add "-B" to the end of the part number for bulk packaging

*Designed to meet SMPTE 2082 12G-SDI specifications.

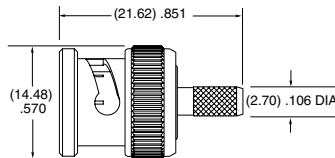

-CA3D

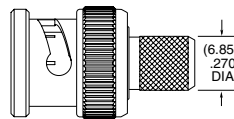

-CA6D

DIE CAST

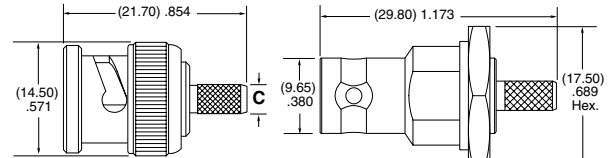

-P-ST-CA3 & -P-ST-CA6

-J-ST-BH3

MACHINED

TERMINATION	C (DIA)
-CA3	(2.70) .106
-CA6	(6.85) .270

Note:
Additional plating options available on Cable Assemblies, Cable Connectors and Board Connectors. Contact RFGroup@samtec.com

75 Ω DIE CAST BNC TO 12 GHz

BNC Board Connectors
BNC7T-TH, BNC7T-BH,
BNC7T-BM, BNC7T-EM

Cable Mates:

RF179, RFA6T, RFB6T,
RFC6T, GRF7H-C



BNC7T	GENDER	TYPE	PLATING	ORIENTATION	TERMINATION	PACKAGING
	-J = Jack	-P = PCB Mount	-GN = 10 μ" (0.25 μm) Gold contact, 100 μ" (2.54 μm) Nickel Shell	-ST = Straight -RA = Right-angle Bulkhead/Panel Mount	-TH2D = Tall Through-hole Die Cast (-ST only) -BH2D* = Low Profile Die Cast Bulkhead Through-hole (-RA only) -BM1D* = Low Profile Die Cast Bulkhead Mixed Technology for (1.60 mm) .062" PCB (-RA only) -BM2D* = Low Profile Die Cast Bulkhead Mixed Technology for (3.18 mm) .125" PCB (-RA only) -EM1D* = Edge Mount Die Cast Bulkhead/Panel Mount for (1.60 mm) .062" PCB (-ST only) -EM2D* = Edge Mount Die Cast Bulkhead/Panel Mount for (2.40 mm) .093" PCB (-ST only)	Leave blank for individually bagged. -B = Bulk packaged (-BH2D only)
	<p>-RA-BM1D (BALANCED FOR PICK-AND-PLACE)</p>					
	<p>-RA-BH2D</p>					
	<p>-ST-EM1D & -ST-EM2D</p>					
				<p>-ST-TH2D</p>		

Notes:
Contact RFGroup@samtec.com for 12G-SDI PCB mount launch characteristics.

Designed to meet SMPTE 2082 12G-SDI specifications.

Additional plating options available on Board Connectors. Contact RFGroup@samtec.com

*Lock washers & knurled nuts supplied with bulkhead/panel mount options

75 Ω MACHINED BNC TO 12 GHz

BNC Board Connectors
BNC7T-TH, BNC7T-BH,
BNC7T-EM

Cable Mates:

RF179, RFA6T, RFB6T,
RFC6T, GRF7H-C



BNC7T	GENDER	TYPE	PLATING	ORIENTATION	TERMINATION	PACKAGING
	-J = Jack	-P = PCB Mount	-GN = 10 μ" (0.25 μm) Gold contact, 100 μ" (2.54 μm) Nickel Shell	-ST = Straight -RA = Right-angle Bulkhead/Panel Mount	-TH1 = Standard Through-hole (-ST only) -BH1* = Standard Bulkhead Through-hole (-RA only) -EM1* = Edge Mount Bulkhead/Panel Mount for (1.60 mm) .062" PCB (-ST only) -EM2* = Edge Mount Bulkhead/Panel Mount for (2.40 mm) .093" PCB (-ST only)	Leave blank for individually bagged. -B = Bulk packaged (-BH1 only)
	<p>-ST-EM1 & -ST-EM2</p>					
	<p>-RA-BH1</p>					
				<p>-ST-TH1</p>		

Notes:
Contact RFGroup@samtec.com for 12G-SDI PCB mount launch characteristics.

Designed to meet SMPTE 2082 12G-SDI specifications.

Additional plating options available on Board Connectors. Contact RFGroup@samtec.com

*Lock washers & knurled nuts supplied with bulkhead/panel mount options

75 Ω HIGH-DENSITY BNC TO 12 GHz

HIGH-DENSITY BNC Cable Assemblies

RFA6T, RFB6T, RFB8T, RFC6T, RFC8T



SERIES	END 1 CONNECTOR	END 2 CONNECTOR	OVERALL LENGTH
RFC6T* = 12G-SDI, Belden 4694R Cable	-H4SP3 = 75 Ω High-Density BNC Straight Plug		-“XXXX” = Overall Length in millimeters -0300 (300 mm) 11.81" minimum
RFC8T* = 12G-SDI, Belden 4855R Cable			
RFA6T = RG 6 Cable			
RFB6T = Belden 1694A Cable			
RFB8T = Belden 1855A Cable			

ALSO AVAILABLE

75 Ω: DIN 1.0/2.3, BNC = RFB6T, RFA6T, RFC6T

75 Ω: DIN 1.0/2.3 = RFB8T, RFC8T

*Designed to meet SMPTE 2082 12G-SDI specifications.

HIGH-DENSITY BNC Board Connectors

HDBNC-TH, HDBNC-EM, HDBNC-BH, HDBNC-BM

Cable Mates:

RFA6T, RFB6T, RFB8T, RFC6T, RFC8T



HDBNC	GENDER	TYPE	PLATING	ORIENTATION	TERMINATION	PACKAGING
	-J = Jack	-P = PCB Mount	-GN = 10 μ" (0.25 μm) Gold contact, 100 μ" (2.54 μm) Nickel shell	-ST = Straight -RA = Right-angle	-BH1 = Through-hole -BH2 = Through-hole (2.36 mm) .093" PCB (-RA only) -BM1D = Die Cast Bulkhead Mixed Technology for (1.60 mm) .062" PCB (-RA only) -BM2D = Die Cast Bulkhead Mixed Technology for (3.18 mm) .125" PCB (-RA only)	Leave blank for individually bagged. -B Bulk packaged (-BHX only)
					-EM1 = Edge Mount (-ST only) -TH1 = Through-hole, Three Legs (-ST only)	

-RA-BH2

-ST-EM1

-RA-BM1D & -BM2D (BALANCED FOR PICK-AND-PLACE)

-ST-BH1

-ST-TH1

Notes:

Designed to meet SMPTE 2082 12G-SDI specifications.

Additional plating options available on Cable Assemblies, Cable Connectors and Board Connectors. Contact RFGroup@samtec.com

HIGH-DENSITY BNC Cable Connectors

HDBNC-CA



CONNECTORS FOR INDUSTRY STANDARD CABLES	
HDBNC-P-C-GN-ST-CA6	RG 6, Belden 1694A or Belden 4694R Cable
HDBNC-P-C-GN-ST-CA8	Belden 1855A or Belden 4855R Cable

Add "-B" to the end of the part number for bulk packaging (100 max.)

P-C = Cable Plug

GN = Plating (10 μ" Gold on contact, Nickel on outer contact & shell)

ST = Straight

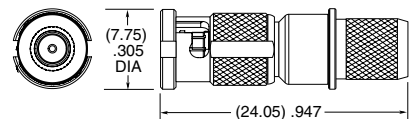

-CA6

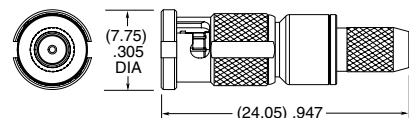

-CA8

Supplied with pins and ferrules. See website with dimensions.

Designed to meet SMPTE 2082 12G-SDI specifications.

DIN Cable Assemblies

RFA6T, RFB6T, RF179, RFB8T, RFC6T, RFC8T



SERIES	END 1 CONNECTOR	END 2 CONNECTOR	OVERALL LENGTH
RFC6T* = 12G-SDI, Belden 4694R Cable RFC8T* = 12G-SDI, Belden 4855R Cable RFA6T = RG 6 Cable RFB6T = Belden 1694A Cable RF179 = RG 179 Cable RFB8T = Belden 1855A Cable	-78SP4 = 75 Ω DIN Straight Plug		-“XXXX” = Overall length in millimeters -0100 (100 mm) 3.94" minimum (RF179) -0300 (300 mm) 11.81" minimum (RFA6T, RFB6T, RFB8T, RFC6T, RFC8T)
ALSO AVAILABLE 75 Ω: HDBNC, BNC = RFB6T, RFA6T, RFC6T 75 Ω: BNC, SMB, MCX, MMCX = RF179 75 Ω: HDBNC = RFB8T, RFC8T			

*Designed to meet SMPTE 2082 12G-SDI specifications.

DIN Board Connectors

DIN7A-TH, DIN7A-BH

Cable Mates:

RFA6T, RFB6T, RF179, RFB8T, RFC6T, RFC8T, GRF7H-C



DIN7A	GENDER	TYPE	PLATING	ORIENTATION	TERMINATION	PACKAGING
	-J = Jack	-P = PCB Mount	-GF = 10 μ" (0.25 μm) Gold center contact, 3 μ" (0.08 μm) Gold outer contact, 100 μ" (2.54 μm) Nickel body -RA only)	-ST = Straight (-TH1 only) -RA = Right-angle (-BH1 only)	-TH1 = Through-hole (-ST only) -BH1 = Bulkhead Through-hole (-RA only)	Leave blank for individually bagged. -B = Bulk packaged (-BH1 only)
				-ST-TH1	NUT	-RA-BH1

Notes:

Contact RFGroup@samtec.com for 12G-SDI PCB mount launch characteristics.

Designed to meet SMPTE 2082 12G-SDI specifications.

Additional plating options available on Cable Assemblies, Cable Connectors and Board Connectors. Contact RFGroup@samtec.com

DIN Cable Connectors

DIN7A-CA



CONNECTORS FOR INDUSTRY STANDARD CABLES	
DIN7A-PP-C-GF-ST-CA3	RG 179
DIN7A-PP-C-GF-ST-CA6	*RG 6, Belden 1694A or Belden 4694R Cable
DIN7A-PP-C-GF-ST-CA8	*Belden 1855A or Belden 4855R Cable

Add "-B" to the end of the part number for bulk packaging (100 max.)

*Designed to meet SMPTE 2082 12G-SDI specifications.

PP-C = Push Pull Plug Cable

GF = Plating (10 μ" Gold on center contact, Flash Gold on outer contact, Nickel on Shell)

ST = Straight

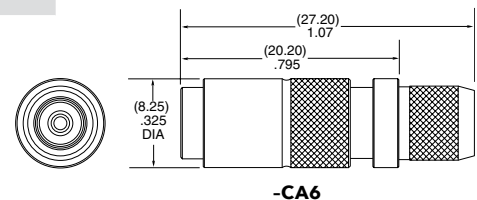

-CA6

Supplied with pins and ferrules. See website for dimensions

75 Ω SMB TO 4 GHz

SMB Cable Connectors RF179

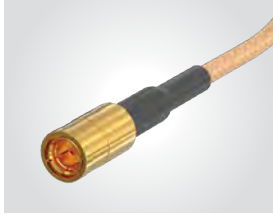

SERIES	END 1 CONNECTOR	END 2 CONNECTOR	OVERALL LENGTH
--------	-----------------	-----------------	----------------

RF179
= RG 179 Cable

-77SP1
= 75 Ω SMB Straight Plug

-77RP1
= 75 Ω SMB Right-angle Plug

-“XXXX”
= Overall Length in millimeters
-0100 (100 mm) 3.94" minimum

ALSO AVAILABLE

75 Ω: DIN 1.0/2.3, BNC, MCX, MMCX = RF179

SMB Cable Connectors SMB7H-TH, SMB7H-EM

Cable Mates:
RF179, GRF7H-C

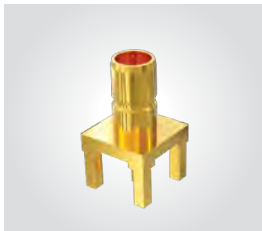

SMB7H	GENDER	TYPE	PLATING	ORIENTATION	TERMINATION
-------	--------	------	---------	-------------	-------------

-J
= Jack

-P
= PCB Mount

-H
= 30 μ" (0.76 μm) Gold center contact,
3 μ" (0.08 μm) Gold outer contact

-ST
= Straight

-RA
= Right-angle

-TH1
= Through-hole ((0.90 mm) .035" DIA Signal Pin)

-TH2
= Through-hole ((0.51 mm) .020" DIA Signal Pin) (-ST only)

-EM1
= Edge Mount (-ST only)

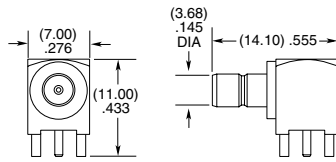

-RA-TH1

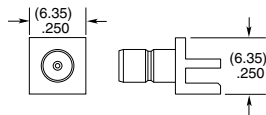

-ST-EM1

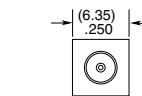

-ST-TH1 & -ST-TH2

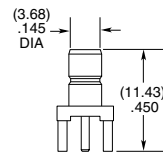

Note:
Additional plating options available on Cable Assemblies, Cable Connectors and Board Connectors. Contact RFGroup@samtec.com

SMB Cable Connectors SMB7H-CA



CONNECTORS FOR INDUSTRY STANDARD CABLES	
SMB7H-P-C-H-ST-CA3	RG 179 Cable
SMB7H-P-C-HF-RA-CA3	RG 179 Cable

P-C = Cable Plug
H or HF = Plating (30 μ" Gold center contact, 3 μ" Gold outer contact)
ST = Straight
RA = Right-angle

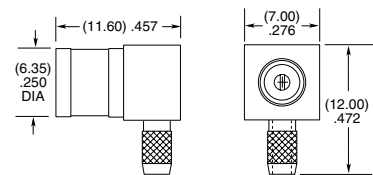

-P-RA

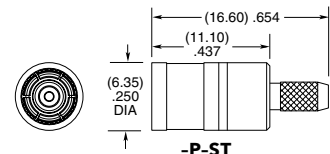

-P-ST

Supplied with pins and ferrules.
See website for dimensions

ORIGINAL SOLUTIONS LOW FREQUENCY RF

SHIELDED TWISTED PAIR SYSTEM

- 100 Ω differential pair
- 28 AWG shielded twisted pair cable assembly
- High reliability BeCu contacts
- 1/4-turn bayonet lock

DC TO
4
GHz

GANGED MICRO-MINI SYSTEMS

- 50 Ω & 75 Ω board stacking and cable assemblies
- High performance rugged contacts
- Variety of End 2 connectors (GRF1H-C, GRF7H-C Series)

DC TO
5
GHz

ISORATE® SYSTEMS

- 50 Ω board stacking and cable assemblies
- Isolated signal systems for 90 percent performance of traditional RF at 50 percent of the cost

DC TO
9.5
GHz

MINI & MICRO-MINI INTERCONNECTS

- 75 Ω impedance (MMCX7 & MCX7 Series)
- Higher extraction forces (MMCXV Series)
- Not intermateable with standard MMCX, MCX

DC TO
6
GHz

HIGH-CYCLE U.FL CABLE PLUG

- 500 cycle U.FL compatible plug (HMHF1 Series)
- .047" DIA flexible cable (RF047 Series)

DC TO
10
GHz

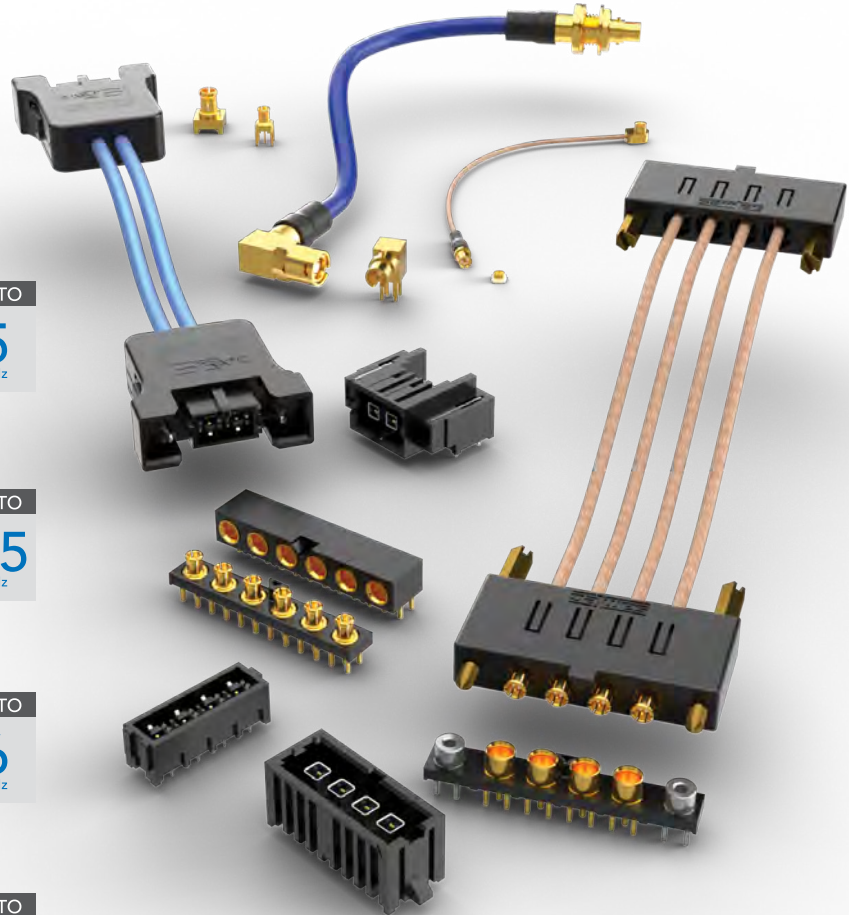

High Frequency Original RF Solutions Available.
See page 11

CABLE SOLUTIONS

SERIES	C28S/CJT	GRF1-C/GRF7-C	GRF1H-C/GRF7H-C	RF047	IJ5C/IJ5H
Application	Shielded Twisted Pair	50 Ω & 75 Ω Micro-Mini Ganged	50 Ω & 75 Ω Micro-Mini Hybrid Ganged	50 Ω .047 DIA Flexible Cable	50 Ω IsoRate®
URL	samtec.com?C28S samtec.com?CJT-BH samtec.com?CJT-TH	samtec.com?GRF1-C samtec.com?GRF7-C	samtec.com?GRF1H-C samtec.com?GRF7H-C	samtec.com?RF047	samtec.com?IJ5C samtec.com?IJ5H

BOARD-TO-BOARD SOLUTIONS

SERIES	GRF1-P/GRF1-J	GRF7-P/GRF7-J	MMCX7	MCX7	MMCXV	IJ5/IP5
Application	50 Ω Micro-Mini Ganged	75 Ω Micro-Mini Ganged	75 Ω Mini and Micro-Mini Interconnects		High-Vibration Micro-Mini	50 Ω IsoRate®
URL	samtec.com?GRF1-P samtec.com?GRF1-J	samtec.com?GRF7-P samtec.com?GRF7-J	samtec.com?MMCX7-TH samtec.com?MMCX7-CA	samtec.com?MCX7 samtec.com?MCX7-CA	samtec.com?MMCXV-TH samtec.com?MMCXV-EM samtec.com?MMCXV-CA	samtec.com?IJ5 samtec.com?IP5

RF DESIGN, DEVELOPMENT & TECHNICAL SUPPORT

SIGNAL INTEGRITY & RF DESIGN EXPERTISE & SUPPORT

- Launch optimization & design services
- Simulation
- Prototyping
- Physical test and measurement verification
- Full channel analysis, system support
- Application specific design and development assistance

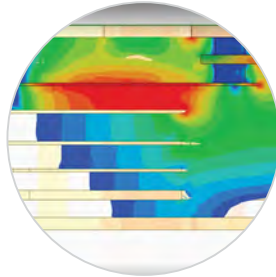

E-field Simulation

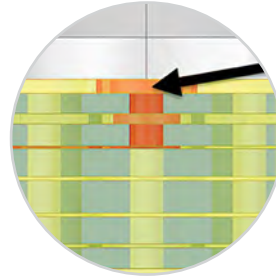

3D Modeling

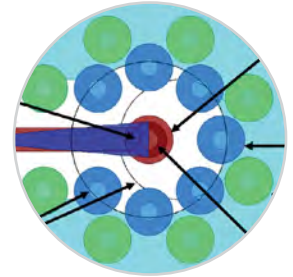

Launch Optimization

TECHNICAL RESOURCES

Samtec's Technical Library contains white papers, application/technical notes, published papers, webinars and presentations on high-performance system design. These resources underscore how Samtec supports interconnectivity needs across multiple industries, applications, performance requirements and operating environments.

WHITE PAPERS

- Wideband RF Launches
- Impacts of Solder Reflow on RF Connectors
- Millimeter Wave Design
- Visit [samtec.com/tech-library](https://www.samtec.com/tech-library)

TECHNICAL REPORTS

- Precision Alignment in Test and Measurement Applications: [samtec.com/alignment](https://www.samtec.com/alignment)

PRESENTATIONS & WEBINARS

- Understanding Transmission Line Discontinuities: [samtec.com/system-impedance](https://www.samtec.com/system-impedance)
- Precision RF Connector PCB Launches for 224 Gbps Devices: [samtec.com/rf-launches-224](https://www.samtec.com/rf-launches-224)

CUSTOM SOLUTIONS & QUICK-TURN MODIFICATIONS

Samtec's fully vertically integrated business model enables the flexibility to quickly and efficiently identify and/or develop innovative, application-specific interconnect solutions to meet a variety of demands in digital/analog systems.

- Board termination types
- Tin dipping capabilities
- Heat-shrink tubing
- Alternate platings
- Pick & place machine designs
- Automated assembly counterweights
- Contact RFGroup@samtec.com to discuss your system requirements

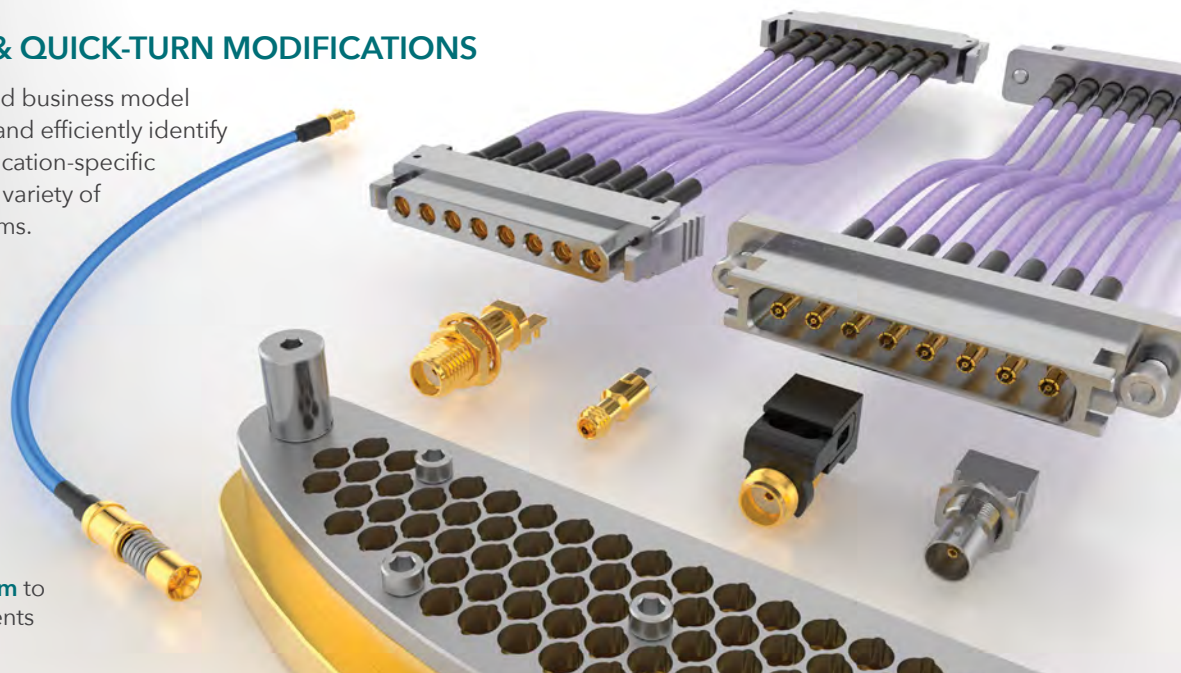

Series	Description	Page	Series	Description	Page
100	50 Ω Precision 1.00 mm Compression Jacks	12	RF047	50 Ω Flexible RF Cable Assembly, (.047" DIA) 28 AWG	45
135	50 Ω Precision 1.35 mm Compression Jacks	13	RF047-A	50 Ω .047" Overshield DIA, 29 AWG mmWave Cable	12-16, 18-19, 22
185	50 Ω Precision 1.85 mm Compression Jacks	14	RF058	50 Ω RF Cable Assembly, RG 58 Cable	34, 37
240	50 Ω Precision 2.40 mm Compression Jacks	15	RF085	50 Ω .085" Overshield DIA 24 AWG mmWave Cable	15, 16
292	50 Ω Precision 2.92 mm Compression Jacks	16	RF086	50 Ω .086" Overshield DIA 23 AWG mmWave Cable	14-16, 18-19, 22
BE90A	90 GHz Bulls Eye® Assembly, Single or Double Row	29	RF23C	50 Ω mmWave Cable, 23 AWG, Copper Shield	15-16, 18-19, 22
BE70A	70 GHz Bulls Eye® Assembly, Single or Double Row	30	RF23S	50 Ω μWave Cable, 23 AWG Solid FEP Dielectric	17
BE40A	50 GHz & 40 GHz Bulls Eye® Assembly, Double Row	30	RF25S	50 Ω μWave Cable, 25 AWG Solid FEP Dielectric	18, 22
BNC5-CA	50 Ω BNC Cable Connectors	38	RF174	50 Ω RF Cable Assembly, RG 174 Cable	34-39
BNC7T	75 Ω 12G-SDI BNC Jacks	41	RF178	50 Ω RF Cable Assembly, RG 178 Cable	34-39
BNC7T-CA	75 Ω 12G-SDI BNC Cable Connectors	40	RF179	75 Ω RF Cable Assembly, RG 179 Cable	40, 43-44
C28S	100 Ω Shielded Twisted Pair Twinax Cable Assembly	45	RF180	50 Ω .178" Overshield DIA, 16 AWG μWave Cable	18, 24-25
CJT	100 Ω Twinax Jacks	45	RF280	50 Ω .277" Overshield DIA, 11 AWG μWave Cable	18, 24-25
DIN7A	75 Ω, 12G-SDI DIN 1.0/2.3 Jacks	43	RF316	50 Ω RF Cable Assembly, RG 316 Cable	34-39
DIN7A-CA	75 Ω, 12G-SDI DIN 1.0/2.3 Cable Connectors	43	RF402	50 Ω RG 402 19 AWG Semi-flexible μWave Cable	18
GC47	50 Ω Precision Ganged SMPM Assembly, .047" Cable	20	RF405	50 Ω RG 405 24 AWG Semi-flexible μWave Cable	18, 22
GC86	50 Ω Precision Ganged SMPM Assembly, .086" Cable	20	RFA6T	75 Ω RF Cable Assembly, RG 6 Cable	40, 42-43
GPPB	50 Ω Precision Ganged SMPM Block, Board-to-Board	21	RFB6T	75 Ω RF Cable Assembly, 1694A Cable	40, 42-43
GPPC	50 Ω Ganged SMPM Cable Board Mates	20, 21	RFB8T	75 Ω RF Cable Assembly, 1855A Cable	42-43
GRF1-C	5.00 mm 50 Ω Ganged Micro-Mini RF Plugs, Cable	45	RFC6T	75 Ω RF Cable Assembly, Belden 4694R Cable	40, 42-43
GRF1H-C	5.00 mm 50 Ω Ganged Hybrid Micro-Mini RF Cable	45	RFC8T	75 Ω RF Cable Assembly, Belden 4855R Cable	42-43
GRF1-J	5.00 mm 50 Ω Ganged Micro-Mini RF Jacks, PCB Mount	45	RS316	50 Ω RF Cable Assembly, Double-Shielded RG 316 Cable	34-38
GRF1-P	5.00 mm 50 Ω Ganged Micro-Mini RF Plugs, PCB Mount	45	SMB5	50 Ω SMB Jacks	39
GRF7-C	5.00 mm 75 Ω Ganged Micro-Mini RF Plugs, Cable	45	SMB5-CA	50 Ω SMB Cable Connectors	39
GRF7H-C	5.00 mm 75 Ω Ganged Hybrid Micro-Mini RF Cable	45	SMB7H	75 Ω SMB Jacks	44
GRF7-P	5.00 mm 75 Ω Ganged Micro-Mini RF Plugs, PCB Mount	45	SMB7H-CA	75 Ω SMB Cable Connectors	44
GRF7-J	5.00 mm 75 Ω Ganged Micro-Mini RF Jacks, PCB Mount	45	SMA	50 Ω Precision SMA Jacks	18
HDBNC	75 Ω, 12G-SDI High-Density BNC Jacks	42	SMA-CA	50 Ω SMA Low Frequency Cable Connectors	34
HDBNC-CA	75 Ω, 12G-SDI High-Density Cable Connectors	42	SMP	50 Ω Precision SMP Plugs & Bullet Adaptors	23
IJ5	4.00 mm IsoRate® 50 Ω High Isolation RF Jack Strip	45	SMPM	50 Ω Precision SMPM Plugs	19
IJ5C	4.00 mm IsoRate® 50 Ω High Isolation RF Cable	45	TNC	50 Ω TNC Jacks	37
IJ5H	4.00 mm IsoRate® 50 Ω High Isolation Hybrid Cable	45	TNC-CA	50 Ω TNC Cable Connectors	37
IP5	4.00 mm IsoRate® 50 Ω High Isolation RF Plug Strip	45	WF12	E-Band Flexible Waveguide Assembly	31
LL043	43.5 GHz Nitrowave™ High-Performance μWave Cable	9	WF15	V-Band Flexible Waveguide Assembly	31
MCX	50 Ω MCX Jacks & Plugs	35	WGBA	Between-Series Waveguide Flange Adaptor	31
MCX7	75 Ω MCX Jacks & Plugs	45			
MCX7-CA	75 Ω MCX Cable Connectors	45			
MCX-CA	50 Ω MCX Cable Connectors	35			
MMCX	50 Ω MMCX Jacks & Plugs	36			
MMCX-CA	50 Ω MMCX Cable Connectors	36			
MMCX7	75 Ω MMCX Jacks & Plugs	45			
MMCXV	50 Ω MMCX High-Vibration Jacks & Plugs	45			
MMCXV-CA	50 Ω MMCX High-Vibration Cable Connectors	45			
MH081	50 Ω Micro High Frequency RF Cable, 0.81 mm DIA	33			
MH113	50 Ω Micro High Frequency RF Cable, 1.13 mm DIA	33			
PRF00	Precision SMP Cable Connectors, 40 GHz	22			
PRF01	Precision SMA Cable Connectors, 26.5 GHz	18			
PRF04	Precision TNCA Cable Connectors, 18 GHz	25			
PRF06	Precision N Type Cable Connectors, 18 GHz	24			
PRF10	Precision 1.00 mm Cable Connectors, 110 GHz	12			
PRF13	Precision 1.35 mm Cable Connectors, 90 GHz	13			
PRF18	Precision 1.85 mm Cable Connectors, 65 GHz	14			
PRF24	Precision 2.40 mm Cable Connectors, 50 GHz	15			
PRF92	Precision 2.92 mm Cable Connectors, 40 GHz	16			
PRF35	Precision 3.50 mm Cable Connectors, 34 GHz	17			
PRFIA	Precision 50 Ω In-Series Bullet Adaptors	26			
PRFBA	Precision 50 Ω Between-Series Bullet Adaptors	27			
PRFMO	Precision SMPM Cable Connectors, 65 GHz	19			
PRFS1	Precision SSMA Cable Connectors, 34 GHz	17			





Scan the Code to Find Your
Samtec Location or Visit:
[samtec.com/locations](https://www.samtec.com/locations)

samtec
SUDDEN SERVICE®

[samtec.com/RF](https://www.samtec.com/RF)

© DECEMBER 2023, SAMTEC INC.