

MAKANDA TWP. FIRE DEPT.

PUMPER

TID NO. 13136



BODY

- Bolted Painted Stainless Steel Body
- ROM Roll Up Doors
- Rear Slide-In Ladder and Pike Pole Storage
- Coffin Compartment Hard Suction Storage
- Storage for 8 SCBA Bottles in Wheel Wells
- Toyne Custom Slide Out Shelves
- Rear Mounted Ladder for Easy Hosebed Access
- Roll Out Toolboards and Trays
- In-Compartment SCBA Brackets

CHASSIS

- International HV607 2 Door
- Cummins ISL9 450 Engine
- 3000 EVS Transmission
- Back Up Camera
- FireCom Intercom System
- Custom Lettering and Striping

TANK

- UPF 1000 Gallon Tank
- ICI SL Plus Tank Gauge
- Rear 2.5" Direct Tank Fill

PUMP

- Waterous CSU 1500 GPM Pump
- Fire Research Pump Boss Pressure Governor
- (2) 1.75" Crosslays
- Left side: (2) 2.5" Discharges
2.5" Intake
Master Intake
- Right side: 2.5" Discharge
3" Discharge
2.5" Intake
Master Intake
- Elkhart Stinger Monitor
- Front Bumper Hosewell with 1.75" Discharge
- Hosebed 2.5" Pre Connect,

ELECTRICAL

- Whelen M9 LED Scene Lights
- Whelen Warning Lighting
- Whelen LED Arrowstick
- FireTech Hi Viz 46" LED Brow Light
- Smart Power 6000 Watt Hydraulic Generator
- ILI LED Strip Compartment Lighting
- Electric Cord Reel

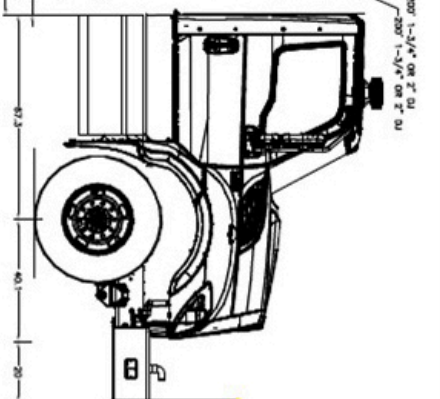
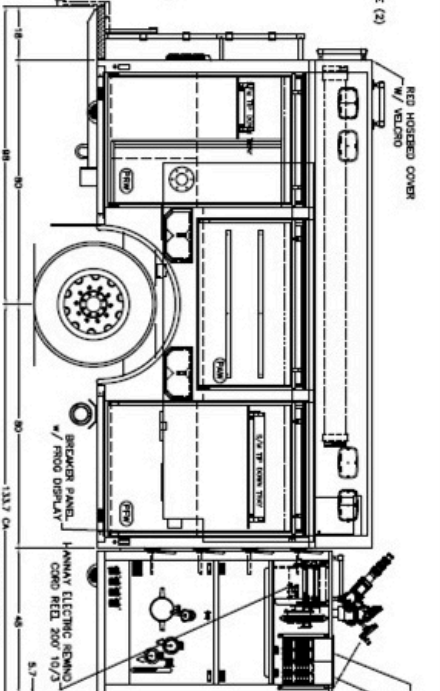
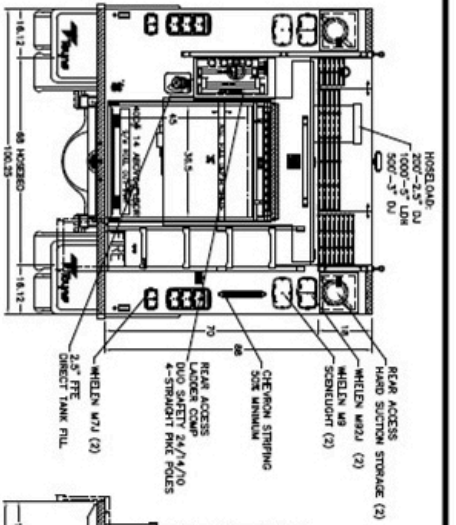

COMP.	HEIGHT	WIDTH	USABLE DEPTH		DIMENSION	FT.
			UPPER	LOWER		
OPW	67.12	47.89	1.4	2.6	28	35.35
DAW	37.12	63.75	1.4	2.6	28	18.69
OPW	67.12	46.00	1.4	2.6	28	32.48
DAW	37.12	63.75	1.4	2.6	27	44.99
OPW	67.12	47.89	1.4	2.6	27	31.13
DAW	37.12	63.75	1.4	2.6	27	44.99
HOUSED	67.12	44.00	1.4	2.6	27	38.82
FRONT X-LAY	16	7.5	—	2.3	25	5.12
REAR X-LAY	16	7.5	—	2.3	25	5.12

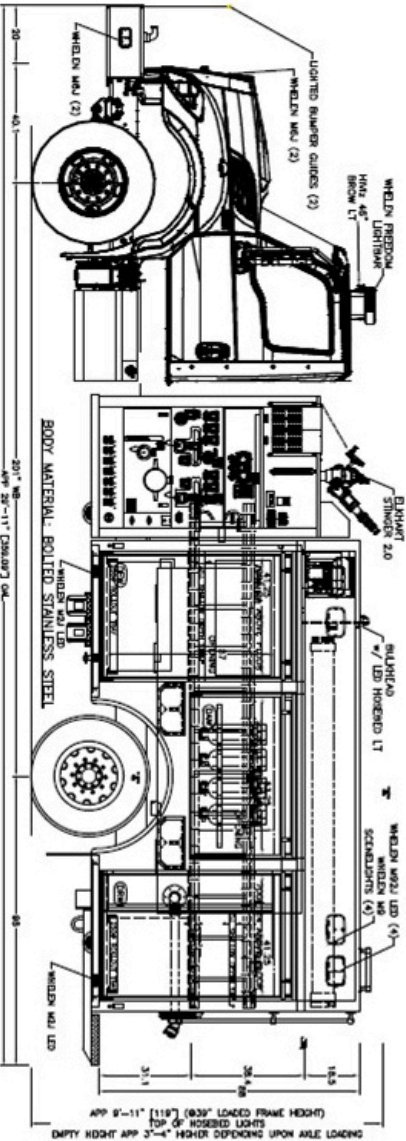
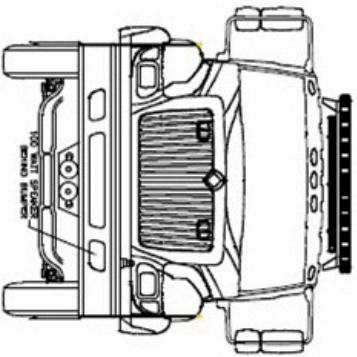
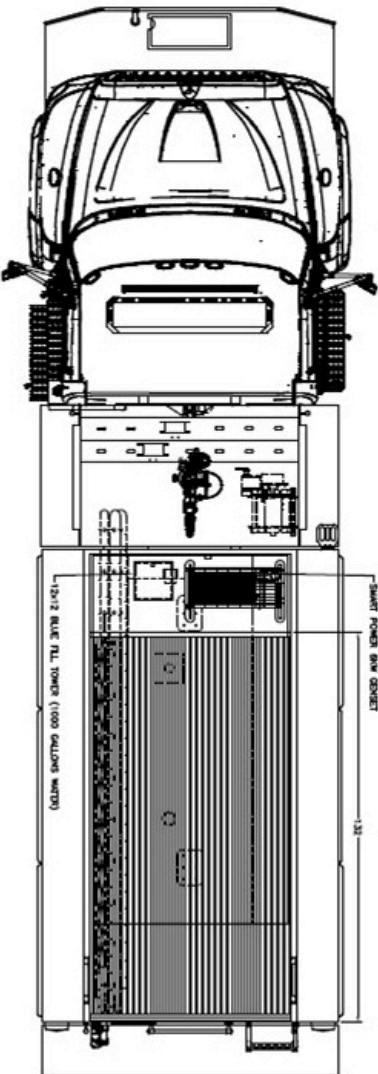

125

NOTE:
DIMENSIONS SHOWN ARE APPROXIMATE AND ARE SUBJECT TO MINOR CHANGE AS MAY BE FOUND NECESSARY DURING CONSTRUCTION. MINOR DETAILS MAY NOT BE SHOWN. IF DISCREPANCIES EXIST BETWEEN THIS DRAWING AND THE WRITTEN SPECIFICATIONS PROVIDED BY JONE, THE WRITTEN SPECIFICATIONS SHALL PREVAIL.

ORIGINAL DRAWING	INTERNATIONAL HV607 2000R 4x2	SCALE: 1/66	SHEET: A
REV A	201"-132.6"-47" D17	CITY: MAKANDA	
ISR	BOLTED STAINLESS STEEL	STATE: ---	
REVIEW	WATEROUS CSU 1500	DUR: DFC	
AS BUILT A/W	1000 UPF POLY-TANK III	CAO: GROSSMAN	
	FOAM SYSTEM: N/A	DATE: 18 NOVEMBER 2020	
	GENERATOR: SMART POWER HR6 HYDRAULIC	FILE: MAKANDA20-A	

Toune
MAKANDA
CUSTOM PUMPER

BREDA, IA 51438
800-648-3358
WWW.TOUNE.COM