



NATIONAL AERONAUTICS AND SPACE ADMINISTRATION

SKYLAB

COMMAND SERVICE  
MODULE  
SYSTEMS HANDBOOK

CSM 116 - 119

APRIL 20, 1972

PREPARED BY

FLIGHT CONTROL DIVISION

MANNED SPACECRAFT CENTER  
HOUSTON, TEXAS

1 STANDARDS

2 SEQUENTIAL  
EVENTS SYSTEM

3 ELECTRICAL  
SYSTEM

4 ENVIRONMENTAL  
CONTROL SYS

5 FUEL CELL/  
CRYOGENICS  
SYSTEM

6 COMMUNI-  
CATIONS  
SYSTEM

7 INSTRU-  
MENTATION

8 GUIDANCE AND  
CONTROL  
SYSTEM

9 SERVICE  
PROPULSION  
SYSTEM

10 REACTION  
CONTROL  
SYSTEM

11 MISCELLANEOUS

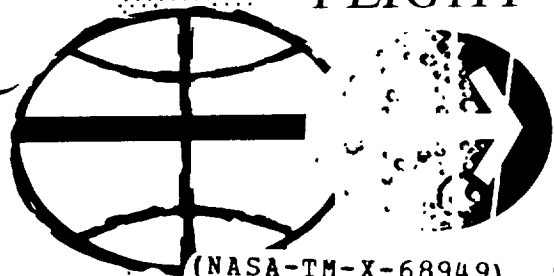
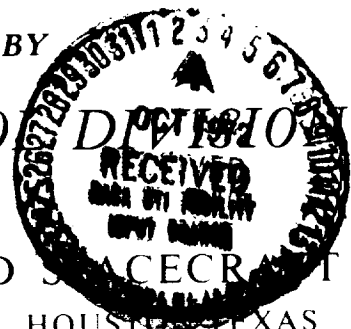
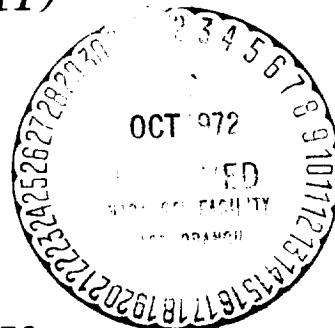

(NASA-TM-X-68949) SKYLAB: COMMAND SERVICE  
MODULE SYSTEMS HANDBOOK, CSM 116 - 119  
(NASA) 20 Apr. 1972 228 p

N72-75717

00/99 Unclas  
41349

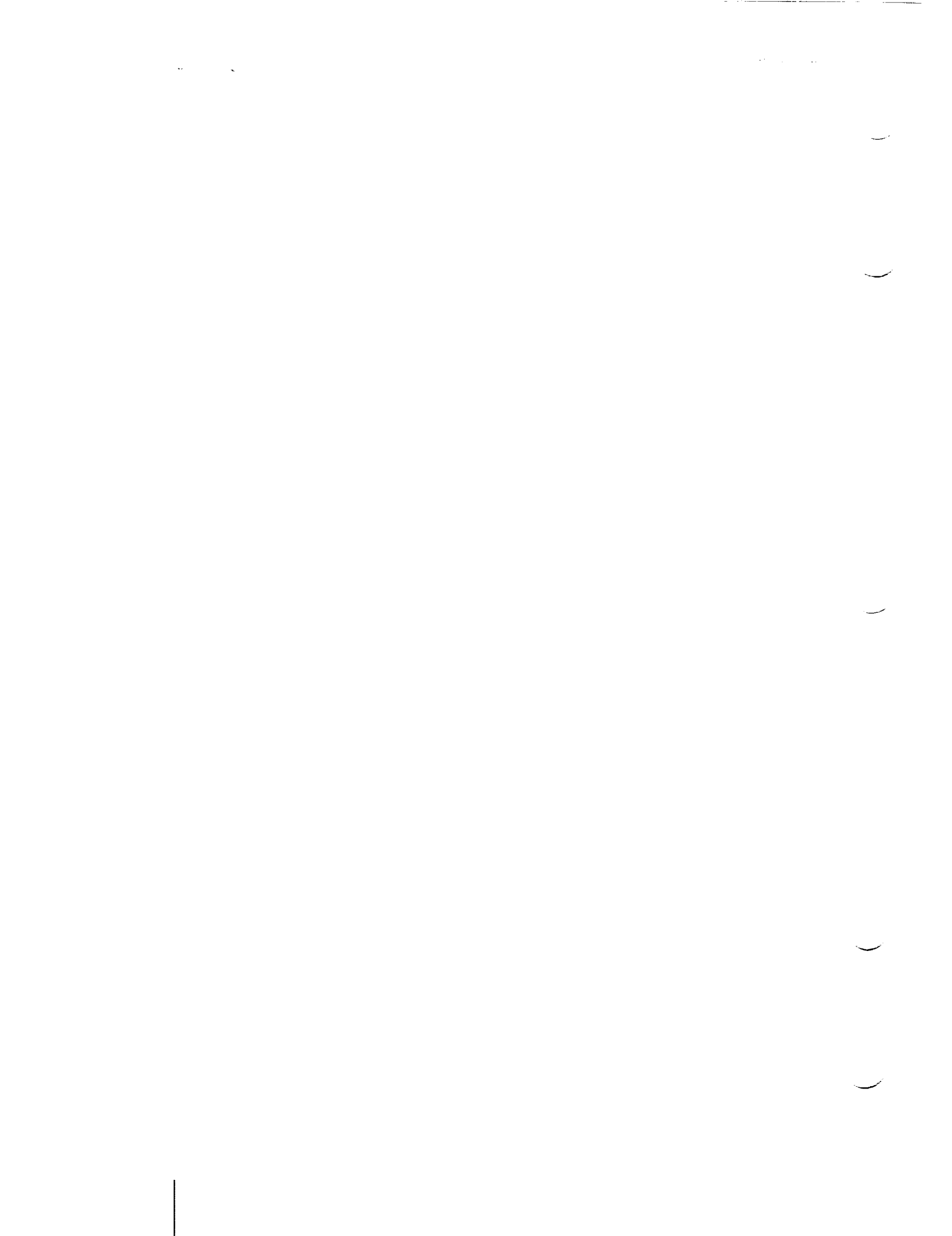

# CSM

SYSTEMS HANDBOOK

CSM 116 - 119

APRIL 20, 1972





SKYLAB

COMMAND/SERVICE MODULE SYSTEMS HANDBOOK

CSM 116-119

PREFACE

This document, prepared by the Flight Control Division, NASA, Manned Spacecraft Center, Houston, Texas, with technical support by North American Rockwell (NR) and Service Technology Corporation (STC), reflects the Command/Service Module Systems for S/C 116 through 119 as of April 20, 1972.

Omitted from this first publication are Sections 5, 7, 8, 9, 10, three figures in Section 3 and one in Section 11. When this material is subsequently published, it will be distributed in document change packages, which may also include revisions to previously published data.

Major emphasis is on material for use by the flight crew and flight controllers during mission operations. Caution should be exercised in using the systems drawings or other information in the handbook for other purposes.

Comments concerning the general contents of this handbook should be directed to FC3/Mr. Fred Whitehead, Jr., NR, Flight Operations Support, 713-483-6206.

This document is not to be reproduced without written approval of the Chief, Flight Control Division, Manned Spacecraft Center, Houston, Texas.

Approved by:

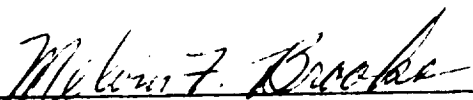
  
\_\_\_\_\_  
Melvin F. Brooks  
Acting Chief, CSM Systems Branch

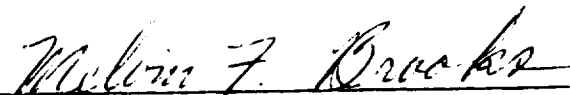
  
\_\_\_\_\_  
Eugene F. Kranz  
Chief, Flight Control Division



ii

SKYLAB  
 COMMAND/SERVICE MODULE SYSTEMS HANDBOOK  
 CSM 116-119  
 APRIL 20, 1972

TABLE OF CONTENTS AND ITEM EFFECTIVITY

ITEM	TITLE	REV/PCN	DOC CHG	SIGNOFF DATE	PAGE	REMARKS
<u>SECTION 1 STANDARDS</u>						
PAR 1.1	GENERAL DRAWING INFORMATION		BASIC	4/20/72	1-1	
PAR 1.2	LINE LEGEND		BASIC	4/20/72	1-3	
PAR 1.3	PIPE LEGEND		BASIC	4/20/72	1-4	
PAR 1.4	TELEMETRY SYMBOLS		BASIC	4/20/72	1-5	
PAR 1.5	ELECTRICAL SYMBOLS		BASIC	4/20/72	1-6	
PAR 1.6	PYROTECHNIC SYMBOLS		BASIC	4/20/72	1-15	
PAR 1.7	MECHANICAL SYMBOLS		BASIC	4/20/72	1-16	
PAR 1.8	MISCELLANEOUS SYMBOLS		BASIC	4/20/72	1-18	
<u>SECTION 2 SEQUENTIAL EVENTS SYSTEM</u>						
DWG 2.1	SEQUENTIAL OVERVIEW		BASIC	4/11/72	2-1	
DWG 2.2	SEQUENTIAL POWER DISTRIBUTION		BASIC	4/11/72	2-2	
DWG 2.3	SEQUENTIAL ABORT INITIATION		BASIC	4/11/72	2-3	
DWG 2.4	SEQUENTIAL LES AND SPS ABORT SUBSYSTEM		BASIC	4/11/72	2-4	
DWG 2.5	SEQUENTIAL EARTH LANDING SUBSYSTEM		BASIC	4/11/72	2-5	
DWG 2.6	SEQUENTIAL UPRIGHTING SYSTEM		BASIC	4/11/72	2-6	
DWG 2.7	DOCKING PROBE WITH CREWMEN OPTICAL ALIGNMENT SIGHT SYSTEM		BASIC	4/11/72	2-7	COAS DETAIL ON DWG APRON
<u>SECTION 3 ELECTRICAL SYSTEM</u>						
DWG 3.1	CSM ELECTRICAL BUS DISTRIBUTION		BASIC	4/11/72	3-1	
DWG 3.2	ELECTRICAL DIRECT CURRENT DISTRIBUTION AND CONTROL SYSTEM		BASIC	4/11/72	3-2	
DWG 3.3	ELECTRICAL ALTERNATING CURRENT DISTRIBUTION AND CONTROL SYSTEM		BASIC	4/11/72	3-3	
DWG 3.4	EXPERIMENT/UTILITY POWER		BASIC	4/11/72	3-4	
DWG 3.5	LIGHTING INTERIOR AND EXTERIOR		BASIC	4/11/72	3-5	
DWG 3.6	TIMER CONTROL		BASIC	4/11/72	3-6	
DWG 3.7	SYSTEM TEST METER		BASIC	4/11/72	3-7	
FIG 3-1	POWER DISTRIBUTION MATRIX - MAIN BUSES		TO BE SUPPLIED			
FIG 3-2	POWER DISTRIBUTION MATRIX - AC BUSES		TO BE SUPPLIED			
FIG 3-3	POWER DISTRIBUTION MATRIX - MISCELLANEOUS BUSES		TO BE SUPPLIED			
<u>SECTION 4 ENVIRONMENTAL CONTROL SYSTEM</u>						
DWG 4.1	ENVIRONMENTAL CONTROL SYSTEM OVERVIEW		BASIC	4/11/72	4-1	
DWG 4.2	SUIT AND CABIN PRESSURIZATION		BASIC	4/11/72	4-2	
DWG 4.3	PRIMARY GLYCOL LOOP		BASIC	4/11/72	4-3	
DWG 4.4	SECONDARY GLYCOL LOOP		BASIC	4/11/72	4-4	
DWG 4.5	WATER AND WASTE MANAGEMENT		BASIC	4/11/72	4-5	
<u>SECTION 5 FUEL CELL/CRYOGENICS SYSTEM</u>						
DWG 5.1	FUEL CELL/CRYOGENIC OVERVIEW		TO BE SUPPLIED			
DWG 5.2	CRYOGENIC GAS STORAGE SYSTEM		TO BE SUPPLIED			
DWG 5.3	FUEL CELL		TO BE SUPPLIED			

TABLE OF CONTENTS AND ITEM EFFECTIVITY 4/20/72 (CONTINUED)

ITEM	TITLE	REV/PCN	DOC CHG	SIGNOFF DATE	PAGE	REMARKS
<u>SECTION 6 COMMUNICATIONS</u>						
DWG 6.1	COMMUNICATION SYSTEM OVERVIEW WITH ANTENNA LOCATIONS DIAGRAM	BASIC		4/11/72	6-1	ANTENNA LOCATIONS ON DWG APRON
DWG 6.2	UNIFIED S-BAND SYSTEM RF EQUIPMENT	BASIC		4/11/72	6-2	
DWG 6.3	SKYLAB CSM VHF AM TRANSCEIVERS AND AUDIO EQUIPMENT	BASIC		4/11/72	6-3	
DWG 6.4	PREMODULATION PROCESSOR	BASIC		4/11/72	6-4	
DWG 6.5	UPDATA LINK	BASIC		4/11/72	6-5	
DWG 6.6	RECOVERY EQUIPMENT	BASIC		4/11/72	6-6	
TABLE 6-I	UNIFIED S-BAND TRANSPONDER AND FM TRANSMITTER	BASIC		4/20/72	6-7	
TABLE 6-II	S-BAND POWER AMPLIFIER	BASIC		4/20/72	6-10	
TABLE 6-III	S-BAND DOWNLINK MODES AND MODULATION PROCESS	BASIC		4/20/72	6-12	
TABLE 6-IV	S-BAND UPLINK MODES AND MODULATION PROCESS	BASIC		4/20/72	6-13	
TABLE 6-V	PREMODULATION PROCESSOR	BASIC		4/20/72	6-14	
TABLE 6-VI	VHF AM TRANSCEIVER EQUIPMENT	BASIC		4/20/72	6-17	
TABLE 6-VII	AUDIO CENTER EQUIPMENT	BASIC		4/20/72	6-19	
TABLE 6-VIII	UPDATA LINK EQUIPMENT	BASIC		4/20/72	6-21	
TABLE 6-IX	VHF RECOVERY BEACON	BASIC		4/20/72	6-24	
TABLE 6-X	VHF SURVIVAL BEACON - TRANSCEIVER	BASIC		4/20/72	6-25	
TABLE 6-XI	ANTENNA SWITCH, S-BAND	BASIC		4/20/72	6-26	
TABLE 6-XII	ANTENNA SWITCH, VHF	BASIC		4/20/72	6-27	
TABLE 6-XIII	ANTENNA, S-BAND OMNI	BASIC		4/20/72	6-28	
TABLE 6-XIV	ANTENNA, VHF SCIMITAR	BASIC		4/20/72	6-29	
TABLE 6-XV	VHF RECOVERY	BASIC		4/20/72	6-30	
TABLE 6-XVI	VHF DIGITAL RANGING GENERATOR	BASIC		4/20/72	6-31	
TABLE 6-XVII	COLOR TELEVISION CAMERA	BASIC		4/20/72	6-33	
TABLE 6-XVIII	DATA STORAGE EQUIPMENT (DSE)	BASIC		4/20/72	6-34	
<u>SECTION 7 INSTRUMENTATION</u>						
PAR 7.1	GENERAL					TO BE SUPPLIED
TABLE 7-I	SIGNAL CONDITIONING EQUIPMENT (SCE) PARAMETER LISTING					TO BE SUPPLIED
TABLE 7-II	INSTRUMENTATION - POWER DISTRIBUTION					TO BE SUPPLIED
DWG 7.1	INSTRUMENTATION POWER AND CONTROL					TO BE SUPPLIED
PAR 7.2	PCM EQUIPMENT (51.2 Kbps) SYSTEM NOTES					TO BE SUPPLIED
TABLE 7-III	PCM EQUIPMENT PARAMETER CAPABILITIES					TO BE SUPPLIED
TABLE 7-IV	PCM EQUIPMENT OPERATING CHARACTERISTICS					TO BE SUPPLIED
PAR 7.3	COLUMN DEFINITIONS FOR PCM EQUIPMENT PARAMETER LOADING TABLES 7-V THROUGH 7-XVIII					TO BE SUPPLIED
TABLE 7-V	CSM PCM TELEMETRY (51.2 Kbps) - STRUCTURES					TO BE SUPPLIED
TABLE 7-VI	CSM PCM TELEMETRY (51.2 Kbps) - ELECTRICAL POWER SYSTEM					TO BE SUPPLIED
TABLE 7-VII	CSM PCM TELEMETRY (51.2 Kbps) - LAUNCH ESCAPE SYSTEM					TO BE SUPPLIED
TABLE 7-VIII	CSM PCM TELEMETRY (51.2 Kbps) - EARTH LANDING SEQUENCE CONTROLLER					TO BE SUPPLIED
TABLE 7-IX	CSM PCM TELEMETRY (51.2 Kbps) - ENVIRONMENTAL CONTROL SYSTEM					TO BE SUPPLIED

TABLE OF CONTENTS AND ITEM EFFECTIVITY (CONTINUED)

ITEM	TITLE	REV/PCN	DOC CHG	SIGNOFF DATE	PAGE	REMARKS
<u>SECTION 7 INSTRUMENTATION (CONTINUED)</u>						
TABLE 7-X	CSM PCM TELEMETRY (51.2 KBPS) - GUIDANCE AND NAVIGATION SYSTEM					TO BE SUPPLIED
TABLE 7-XI	CSM PCM TELEMETRY (51.2 KBPS) - STABILIZATION AND CONTROL SYSTEM					TO BE SUPPLIED
TABLE 7-XII	CSM PCM TELEMETRY (51.2 KBPS) - LIFE SYSTEM					TO BE SUPPLIED
TABLE 7-XIII	CSM PCM TELEMETRY (51.2 KBPS) - FLIGHT TECHNOLOGY					TO BE SUPPLIED
TABLE 7-XIV	CSM PCM TELEMETRY (51.2 KBPS) - SCIENTIFIC EQUIPMENT					TO BE SUPPLIED
TABLE 7-XV	CSM PCM TELEMETRY (51.2 KBPS) - SERVICE PROPULSION SYSTEM					TO BE SUPPLIED
TABLE 7-XVI	CSM PCM TELEMETRY (51.2 KBPS) - REACTION CONTROL SYSTEM					TO BE SUPPLIED
TABLE 7-XVII	CSM PCM TELEMETRY (51.2 KBPS) - CREW SAFETY SYSTEM					TO BE SUPPLIED
TABLE 7-XVIII	CSM PCM TELEMETRY (51.2 KBPS) - COMMUNICATION AND INSTRUMENTATION					TO BE SUPPLIED
TABLE 7-XIX	ELECTRON/PROTON SPECTROMETER SUBCOMMUTATED DATA (SK9075K)					TO BE SUPPLIED
TABLE 7-XX	S071/S072 EXPERIMENT SUBCOMMUTATED DATA (SL9021Y)					TO BE SUPPLIED
DWG 7.2	INSTRUMENTATION PCM SIGNAL FLOW					TO BE SUPPLIED
DWG 7.3	CAUTION AND WARNING SYSTEM					TO BE SUPPLIED
<u>SECTION 8 GUIDANCE AND CONTROL SYSTEM</u>						
DWG 8.1	GUIDANCE AND NAVIGATION OVERVIEW WITH MISCELLANEOUS G & C INFORMATION					TO BE SUPPLIED
DWG 8.2	STABILIZATION CONTROL SYSTEM OVERVIEW (POWER AND SCS SIGNAL AND POWER CODE)					TO BE SUPPLIED
DWG 8.3	STABILIZATION CONTROL SYSTEM OVERVIEW					TO BE SUPPLIED
TABLE 8-I	CMC INPUT/OUTPUT CHANNELS ON TELEMETRY					TO BE SUPPLIED
TABLE 8-II	CSM ALARM CODES					TO BE SUPPLIED
TABLE 8-III	G&N/SCA ASSOCIATED POWER SUPPLY/SWITCH					TO BE SUPPLIED
DWG 8.4	G&N POWER DISTRIBUTION					TO BE SUPPLIED
DWG 8.5	INERTIAL SUBSYSTEM					TO BE SUPPLIED
DWG 8.6	OPTICS SUBSYSTEM					TO BE SUPPLIED
DWG 8.7	SCS POWER DISTRIBUTION					TO BE SUPPLIED
FIG 8-1	SCS LOGIC POWER DISTRIBUTION					TO BE SUPPLIED
DWG 8.8A	ATTITUDE REFERENCE LOGIC					TO BE SUPPLIED
DWG 8.8	ATTITUDE REFERENCE SUBSYSTEM					TO BE SUPPLIED
DWG 8.9A	SCS TVC/RCS ELECTRONICS LOGIC					TO BE SUPPLIED
DWG 8.9	CONTROL ELECTRONICS (ECA/TVC/GYROS)					TO BE SUPPLIED
DWG 8.10	AUTO/MANUAL RCS					TO BE SUPPLIED
DWG 8.11	ENTRY MONITORING SYSTEM					TO BE SUPPLIED
<u>SECTION 9 SERVICE PROPULSION SYSTEM</u>						
DWG 9.1	SERVICE PROPULSION SYSTEM					TO BE SUPPLIED
<u>SECTION 10 REACTION CONTROL SYSTEM</u>						
DWG 10.1	SERVICE MODULE REACTION CONTROL SYSTEM					TO BE SUPPLIED
DWG 10.2	PROPELLANT STORAGE MODULE (PSM)					TO BE SUPPLIED
DWG 10.3	COMMAND MODULE REACTION CONTROL SYSTEM					TO BE SUPPLIED

::

CSM  
S/C 116-119  
BASIC

TABLE OF CONTENTS AND ITEM EFFECTIVITY (CONCLUDED)

ITEM	TITLE	REV/PCN	DOC CHG	SIGNOFF DATE	PAGE	REMARKS
<u>SECTION 11 MISCELLANEOUS</u>						
FIG 11-1 (SHEET 1 OF 3)	CONTROL-DISPLAY FIGURE		BASIC		11-1	
FIG 11-1 (SHEET 2 OF 3)	CONTROL-DISPLAY FIGURE		BASIC		11-2	
FIG 11-1 (SHEET 3 OF 3)	CONTROL-DISPLAY FIGURE		BASIC		11-3	
FIG 11-2	EXTERNAL COMPONENT LOCATIONS		TO BE SUPPLIED			
DWG 11.1.1 THROUGH	NR INBOARD PROFILE DRAWINGS	1.1 STR THROUGH	BASIC		11-5 THROUGH	
DWG 11.1.13		1.13 STR			11-17	

1 STANDARDS

—

—

—

—

—

|



**SECTION 1**  
**STANDARDS**

CSM  
S/C 116-119

1.1 **GENERAL DRAWING INFORMATION**  
1.1.1 Cross-indexing  
1.1.1.1 General drawing configuration

The X coordinate zones are marked alphabetically from the right-hand edge of the sheet (including the 1/2 inch margin). The Y coordinate zones are marked numerically from the bottom right-hand and left-hand corners of the sheet.

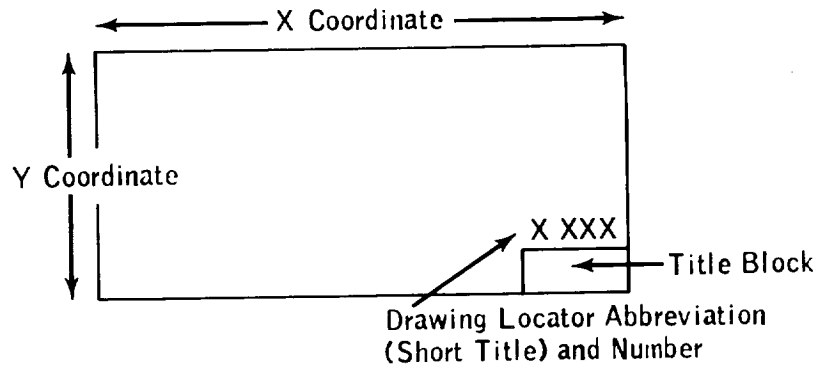

1.1.1.2 Component location code

The component location code is used to reference controls (on the control-display figure) and components (on the overview drawing) into the detail system drawings.



- 3 - Drawing Locator Number for the given detail subsystem drawing
- K - X Coordinate
- 4 - Y Coordinate

1.1.2 Technical Zone References  
1.1.2.1 Zone reference

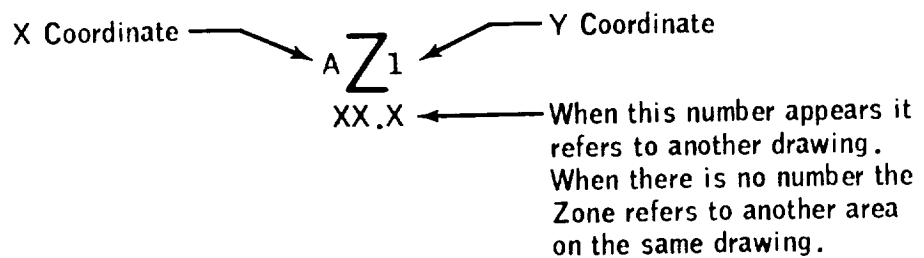

1.1.2.2 Power intra-drawing  
(Section to section within the same drawing)

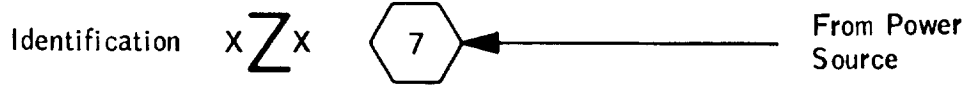
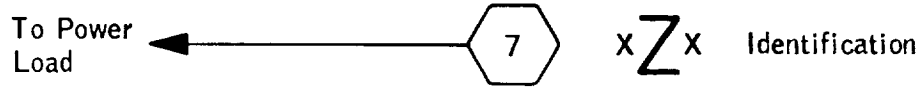

1.1.2.3 Power inter-drawings  
(Drawing to drawing)

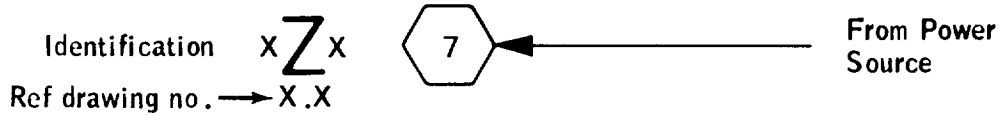
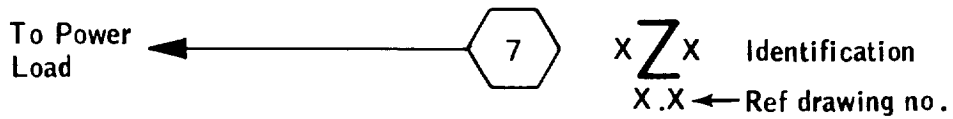

1.2 **LINE LEGEND**

1.2.1 **RF Cable**

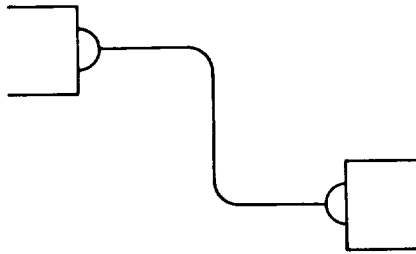

1.2.2 **Electrical Line, Power and control**



1.2.2.1 **Electrical connected**

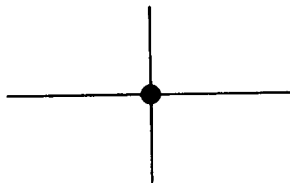

1.2.2.2 **Electrical crossover**



1.2.3 **Directional Flow Arrows**



1.2.4 **Component Enclosures**

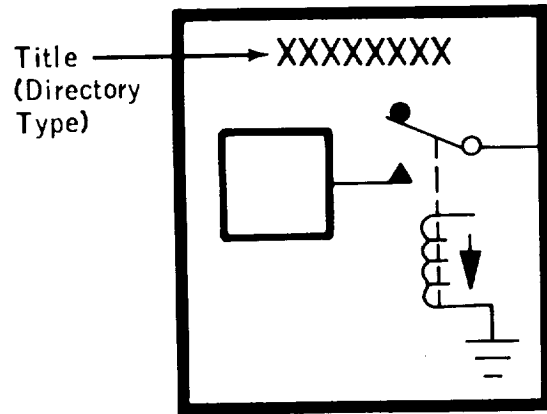

1.2.4.1 **Main enclosure**  
1/16-inch solid black line



1.2.4.2 **Sub enclosure**  
1/32-inch solid black line



1.2.4.3 **Component enclosure with crew (manual control)**  
1/16-inch dashed black line



1.2.4.4 **Module interface and systems assembly**  
1/8-inch dashed black line



1.2.5 **Mechanical Linkage**

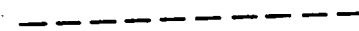

1.2.6 **Timing Pulses**

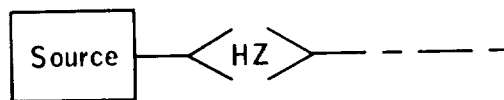

1.3 PIPE LEGEND  
1.3.1 General  
1.3.1.1 Plumbing connected

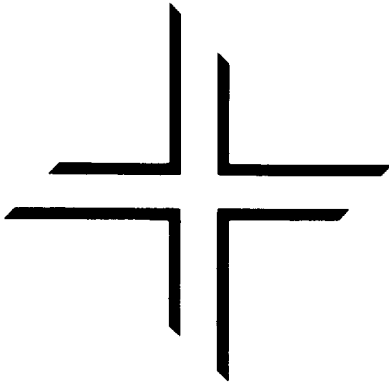

1.3.1.2 Plumbing crossover

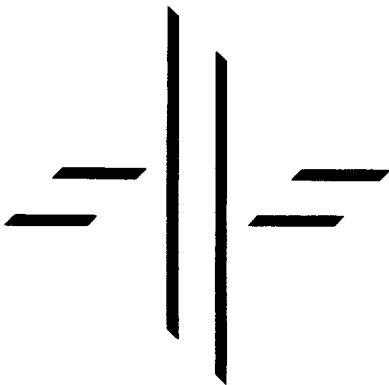

1.3.2 Line designation

1.3.2.1 Water



1.3.2.2 Oxygen



1.3.2.3 Nitrogen

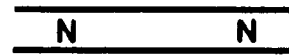

1.3.2.4 Helium



1.3.2.5 Primary Coolant



1.3.2.6 Secondary Coolant



1.3.2.7 Fuel



1.3.2.8 Hydrogen



1.3.2.9 Steam

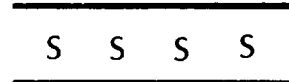

1.3.2.10 Suit Loop



1.3.2.11 Sense Lines



1.3.2.12 Oxidizer



1.3.2.13 Others



1.4  
1.4.1

**TELEMETRY SYMBOLS**  
**Measurements Telemetered**

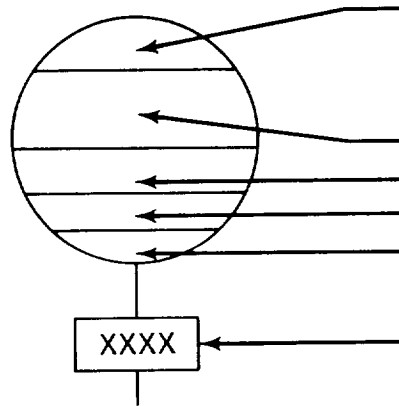

**Measurement Number:** Should include the letter associating it with the transducer type. Alternate system measurement numbers and PCM codes may appear near the TM bubble.

**Measurement Name**  
**Measurement Range**  
**High Bit Sample Rate**  
**Low Bit Sample Rate**

**TM Signal Conditioner:** To be located on the input line next to TM bubble, positioned at 0°, 90°, 180° and 270° around bubble.

1.4.2

**Onboard Meters**

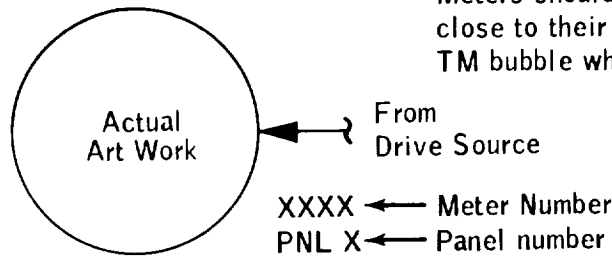

Meters should be placed close to their associated TM bubble wherever possible.

1.4.3  
1.4.3.1

**Sensors**  
**Single source**

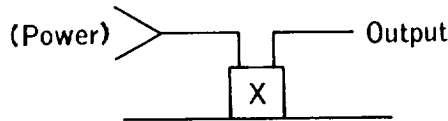

**Example:** Letter indicates the type:  
P - Pressure  
T - Temperature  
Q - Quantity  
W - Wetness  
R - Rate

1.4.3.2

**Double source**

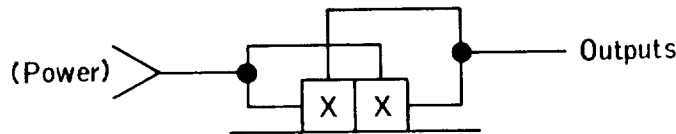

1.4.4  
1.4.4.1

**Ground Commands (Contents Optional by Vehicle)**  
**RTC's**

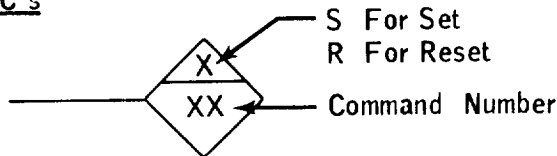

1.5 ELECTRICAL SYMBOLS

1.5.1 Switches

All switches will be shown in the de-energized position (if possible). When a switch has more than one set of contacts, only one set needs to have switch contact nomenclature.

1.5.1.1 Switch nomenclature

Major Title: The title given to a group of switches on the panel.

Minor Title: The title given to a sub-group of switches

Note: If more than one switch has identical major and minor titles, they may be stacked without repeating these titles.

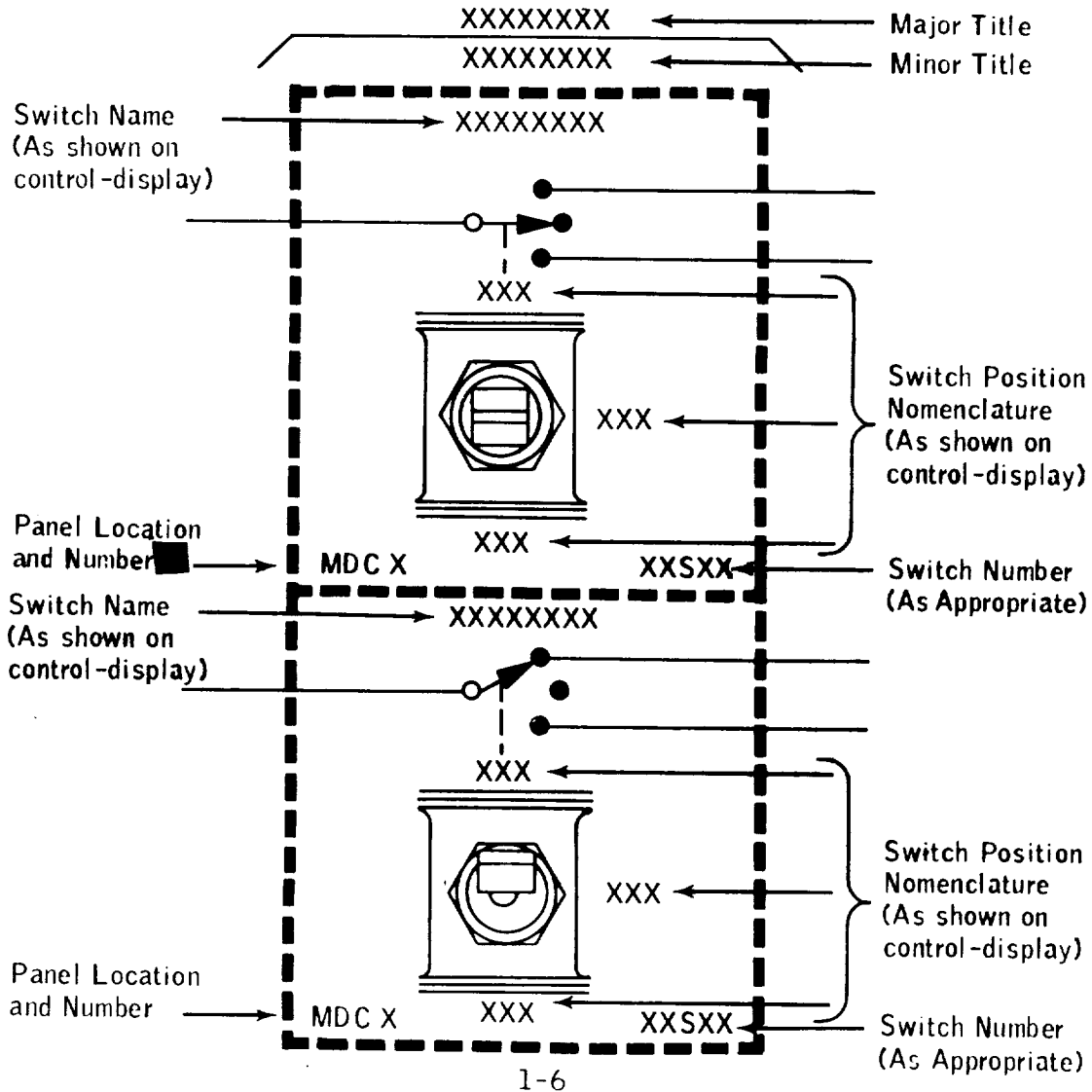

1.5.1.2

Switch controlled flag

If a flag is directly controlled by a switch, it may be shown in the following manner:

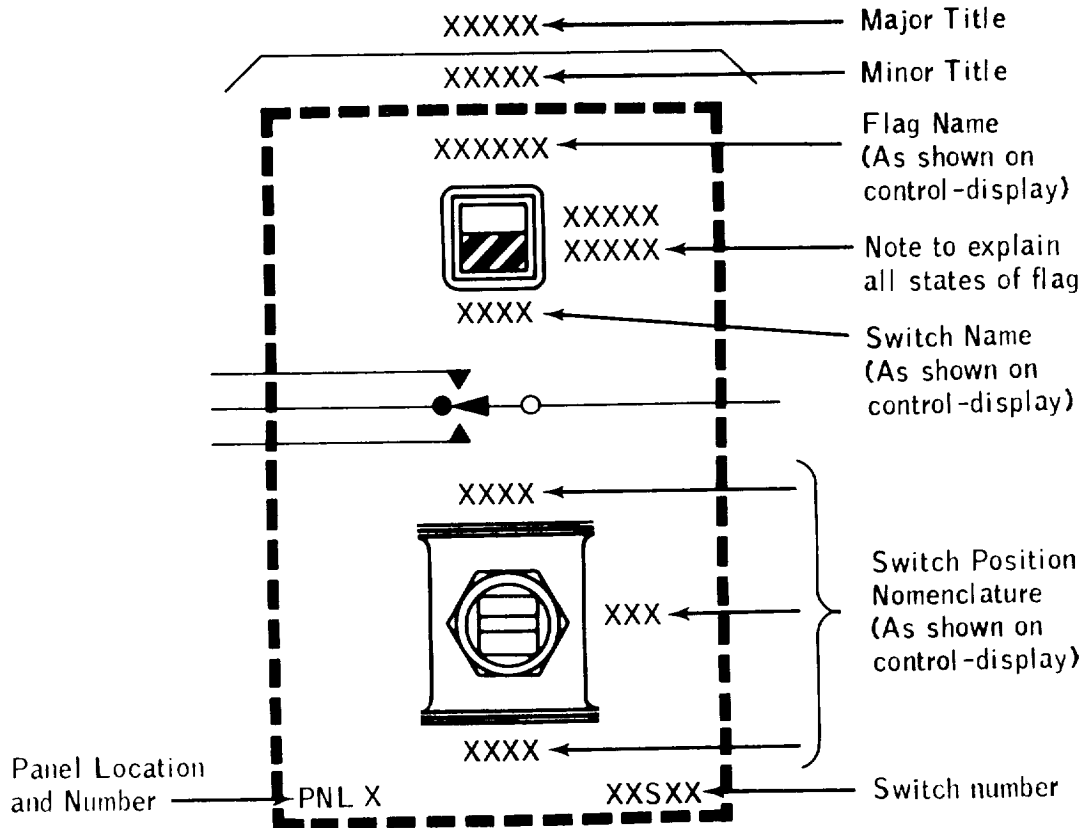

1.5.1.3

Two-position

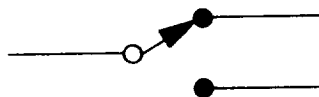

1.5.1.4

Three-position

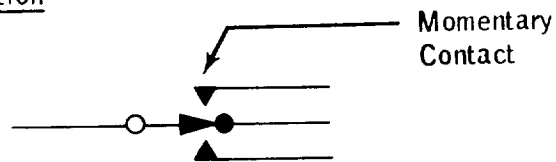

1.5.1.5 Pushbutton  
1.5.1.5.1 Latching

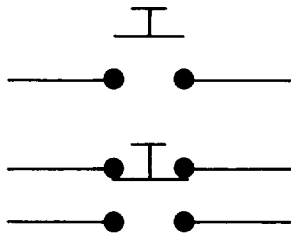

1.5.1.5.2 Momentary

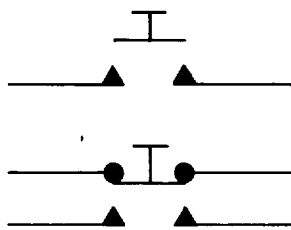

1.5.1.6 Coax

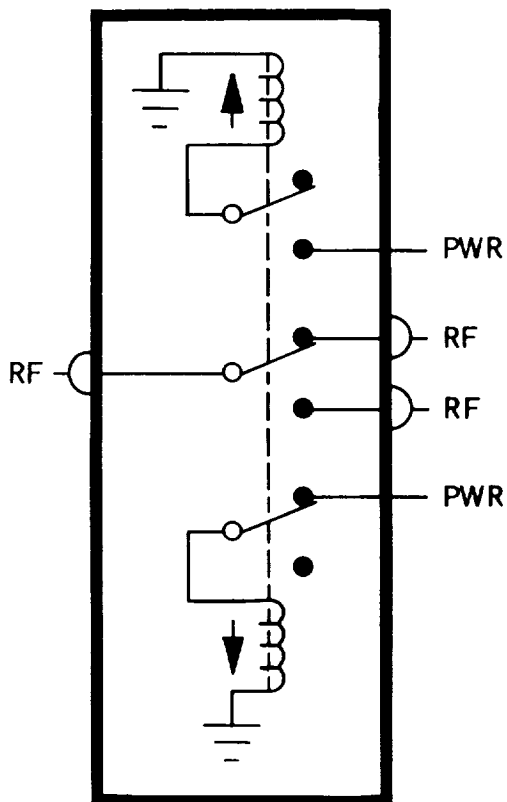

1.5.1.7 Pressure  
1.5.1.7.1 Closed decreased pressure

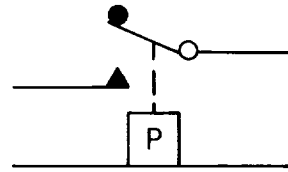

1.5.1.7.2 Closed increased pressure

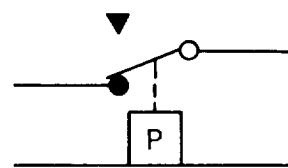

1.5.1.8 Motor  
1.5.1.8.1 Break before make

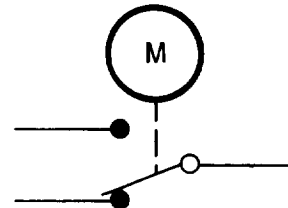

1.5.1.8.2 Make before break

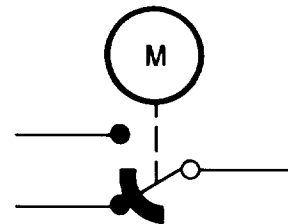

1.5.1.9 Baro

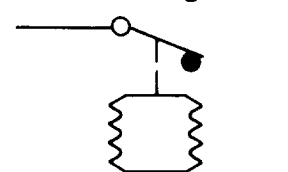

Close XXX psi or altitude  
Open XXX psi or altitude



1.5.2

Circuit Breakers

The circuit breaker should be placed near the associated bus whenever possible. For the difference between major and minor titles see remark under switches (1.5.1.1).

1.5.2.1

Pushbutton

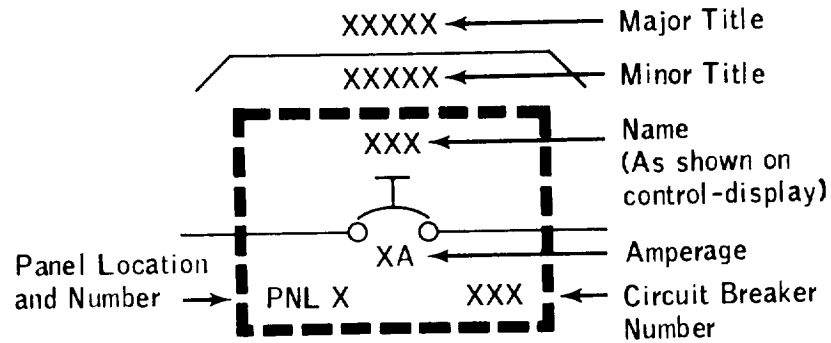

1.5.2.2

Automatic

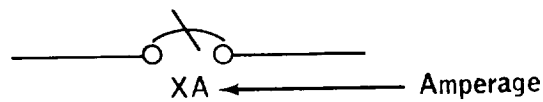

1.5.3

Fuses

1.5.3.1

General

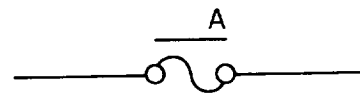

1.5.3.2

Fusistor

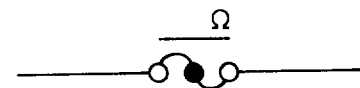

1.5.4

Battery

1/16-inch black tape  
Size varies with number of cells and drawing arrangement.

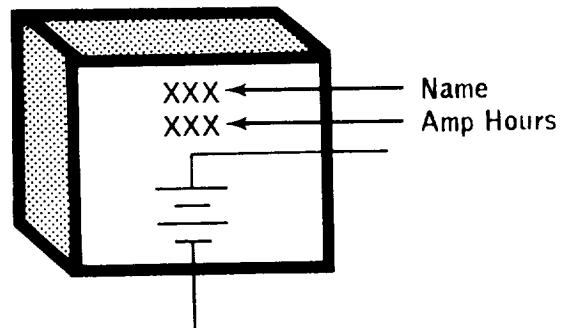

1.5.5  
1.5.5.1

Lights  
Telelights

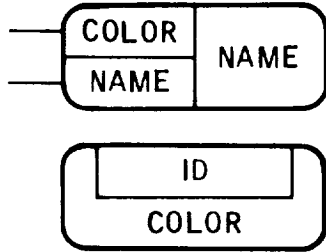

1.5.5.2

Switching

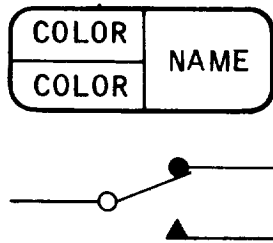

1.5.5.3

Caution and warning

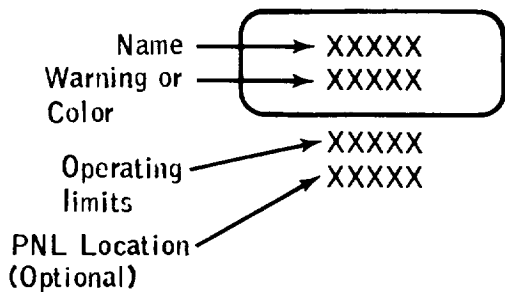

1.5.5.4

Component

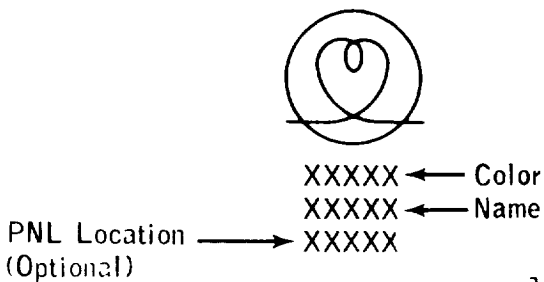

1.5.6

Annunciator Flag  
Flag symbol will not reflect switch position of the associated switch.

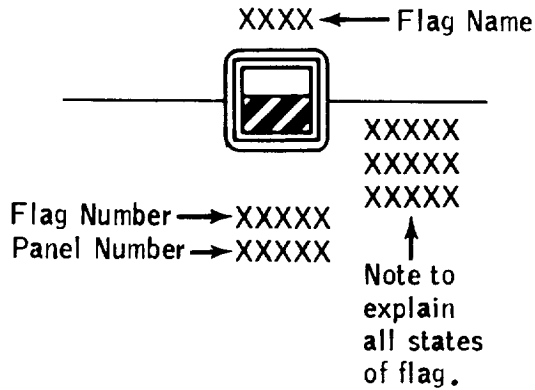

1.5.7

Relays

1.5.7.1

Momentary contact

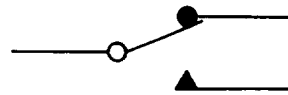

1.5.7.2

Latching contacts

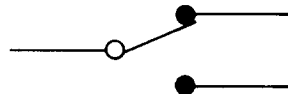

1.5.7.3

Non-Latching relay

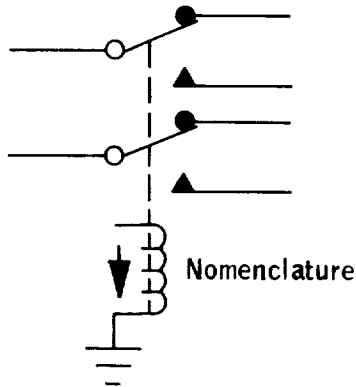

1.5.7.4 Latching relay

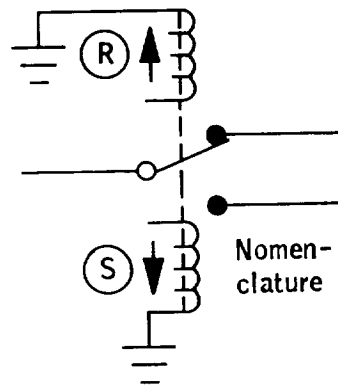

1.5.8 Relay or Solenoid Driver

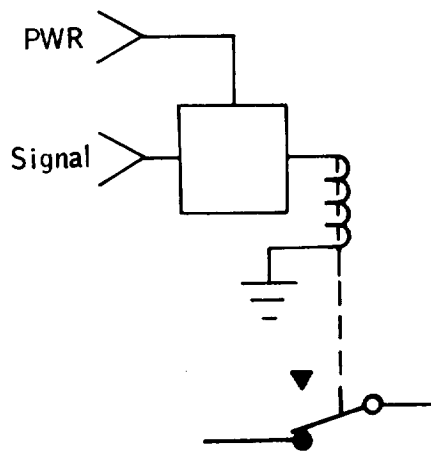

1.5.9  
1.5.9.1 Buses  
Symbol  
Length can vary depending on the bus function on a given drawing.

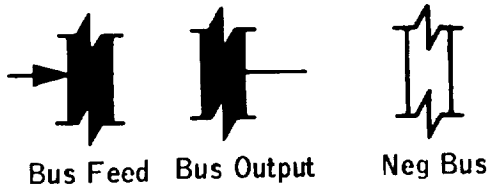

1.5.9.2 Designation  
See bus designation list.



1.5.10  
1.5.10.1 Grounds  
System

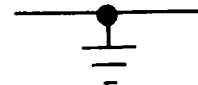

1.5.10.2 Frame

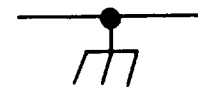

1.5.10.3 Floating or Controlled

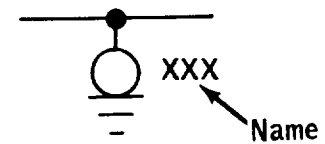

1.5.10.4 Signal

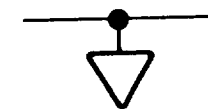

1.5.11  
1.5.11.1 Diodes  
General



1.5.11.2 Zener



1.5.11.3 Tunnel



1.5.11.4 Control rectifier (SCR)



1.5.12 Potentiometer

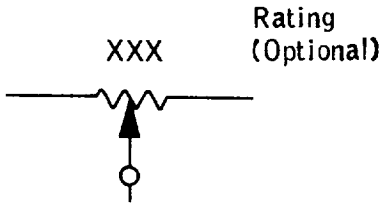

1.5.13 Fixed Resistor

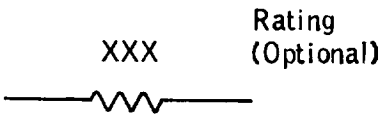

1.5.14 Heater

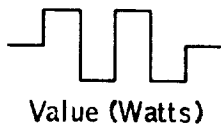

1.5.15 Thermostat



1.5.16 Transformers

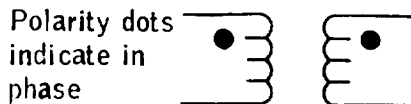
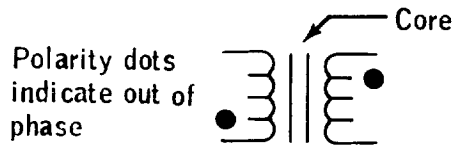

1.5.17 Amplifier

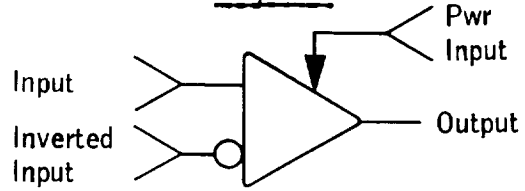

1.5.18 Capacitor

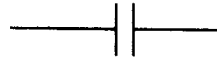

1.5.19 Digital Inverter



1.5.20 Wire Resolver

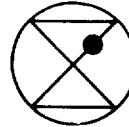

⊗ = Sine Winding

● = Minus Sine

— = Cosine Winding

1.5.21 Time Delay

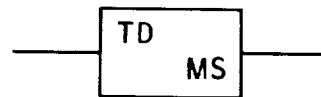

1.5.22 Electrical Filter



1.5.23 Modulator

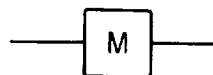

1.5.24 Gates

1.5.24.1

And

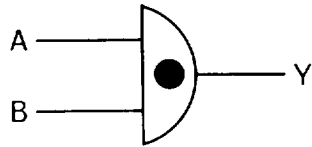

A	B	Y
1	1	1
1	0	0
0	1	0
0	0	0

1.5.24.2

Nand

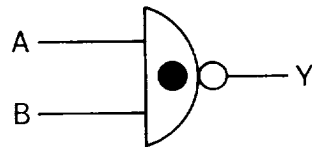

A	B	Y
1	1	0
1	0	1
0	1	1
0	0	1

1.5.24.3

Or

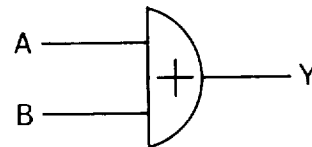

A	B	Y
1	1	1
1	0	1
0	1	1
0	0	0

1.5.24.4

Nor

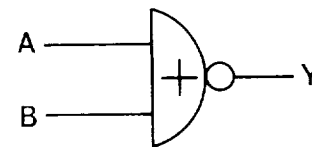

A	B	Y
1	0	0
0	1	0
1	1	0
0	0	1

1.5.24.5

Exclusive Or

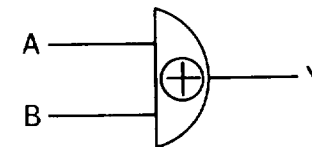

A	B	Y
1	1	0
1	0	1
0	1	1
0	0	0

Open circle means it is an inverter and may appear on any of the lines on the gate.

1.5.24.6

SRT Flip-Flop

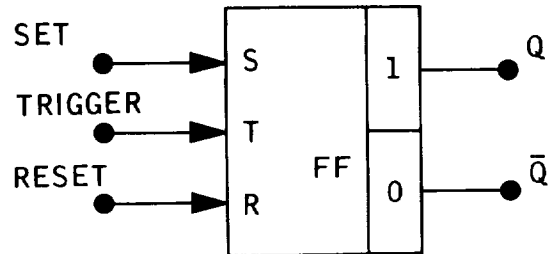

INPUT

OUTPUT

- S Sets Q to "1"  
Sets  $\bar{Q}$  to "0"
- T Q and  $\bar{Q}$  Change States
- R Resets Q to "0"  
Resets  $\bar{Q}$  to "1"

1.5.25

Demodulator



1.5.26

RF Circulator

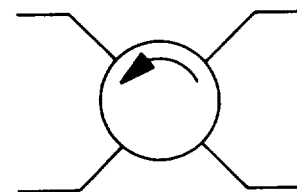

1.5.27     Transistor  
1.5.27.1   NPN

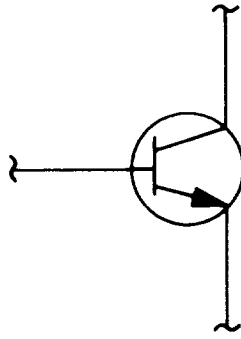

1.5.27.2     PNP

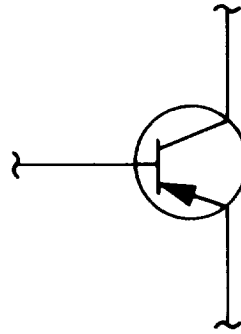

1.5.28     Antenna

Name  
(Type or Function)



1.6 PYROTECHNIC SYMBOLS  
1.6.1 Pyro Guillotine

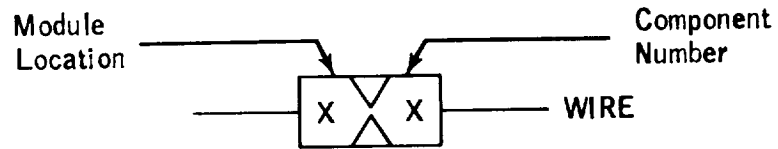

1.6.2 Pyro Valve with Single Initiator

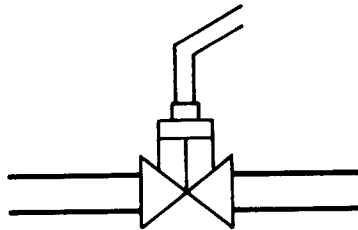

1.6.3 Electrical Circuit Interrupter

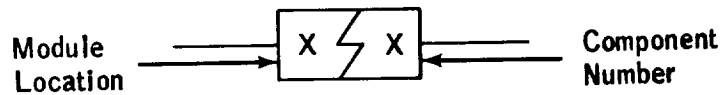

1.7 MECHANICAL SYMBOLS

1.7.1 Mechanical Filter

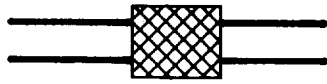

1.7.2 Burst Diaphragm

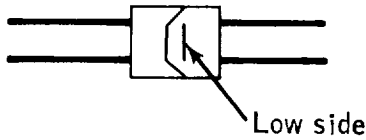

1.7.3 Venturi

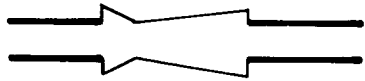

1.7.4 Vent



1.7.5 Thrust Neutralized Vent

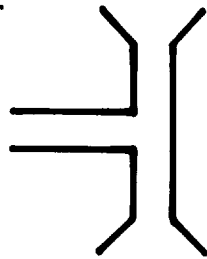

1.7.6 Disconnects

1.7.6.1 Self-sealing



1.7.6.2 Quick

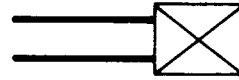

1.7.7 Quick Disconnect Fill and Drain

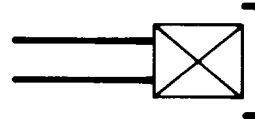

1.7.8 Fill and Drain

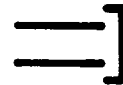

1.7.9 Ball Valve Actuator

May be shown  
in depressed  
or partially  
depressed  
position

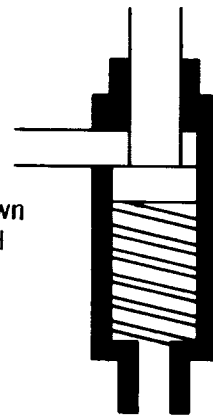

1.7.10 Valves





1.7.10.1 Motor Control

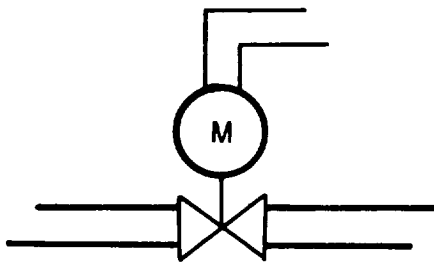

1.7.10.2 Manual Control



1.7.10.3 Check Valve



1.7.10.4 Orifice

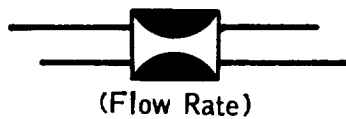

1.7.10.5 Pressure regulator

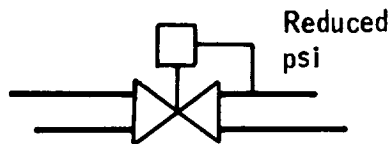

1.7.10.6 Relief Valve

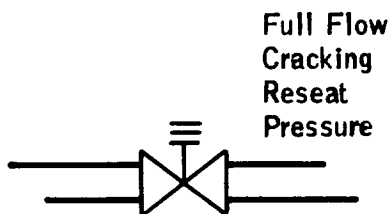

1.7.10.7 Pneumatic controlled valve with line bleed

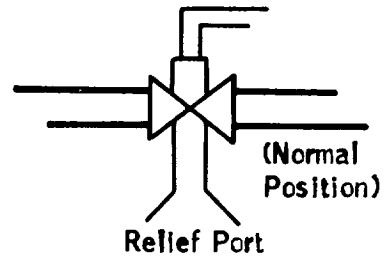

1.7.10.8 Solenoid valve

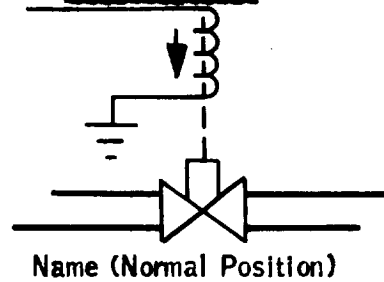

1.7.10.9 Three-way valve

1.7.10.9.1 Manual

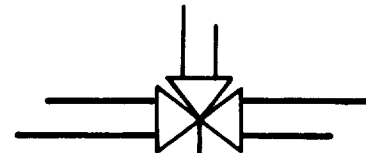

1.7.10.9.2 Solenoid

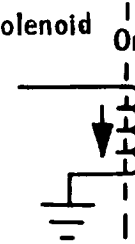

1.7.10.9.3 Motor controlled

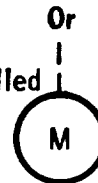

1.7.10.10 Ball valve



1.8 MISCELLANEOUS SYMBOLS  
1.8.1 Drawing Note Reference



1.8.2 Overview Drawing Instrumentation Legend  
1.8.2.1 Automatic control only

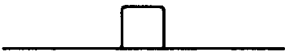

1.8.2.2 PCM only

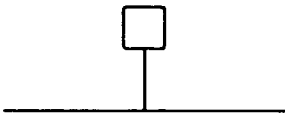

1.8.2.3 PCM and/or onboard display

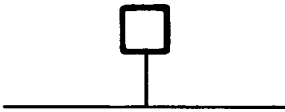

1.8.3 Two-unit Interface

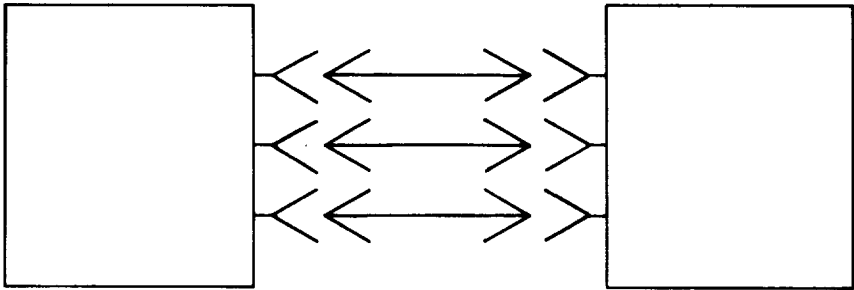

1.8.4 Two-unit Cable Connection

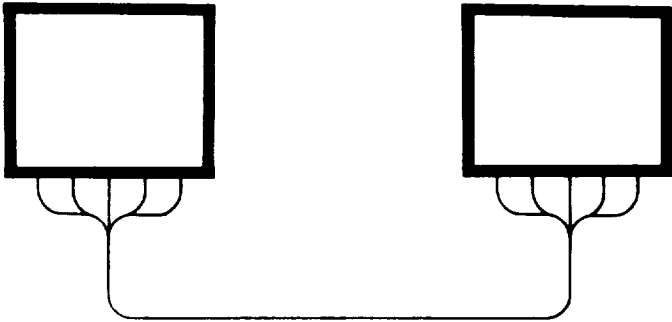

1.8.5	<u>Buses</u>	
1.8.5.1	<u>Power buses .-</u>	Prime CSH generation <u>dwg No.</u>
	V <sub>MA</sub> - MAIN BUS A	3.2
	V <sub>MB</sub> - MAIN BUS B	3.2
	V <sub>BA</sub> - BATTERY BUS A	3.2
	V <sub>BB</sub> - BATTERY BUS B	3.2
	V <sub>BR</sub> - BATTERY RELAY BUS	3.2
	V <sub>FP</sub> - FLIGHT AND POSTLANDING BUS	3.2
	V <sub>E</sub> - EXPERIMENT BUS	3.2
	V <sub>AC1</sub> - AC BUS 1	3.3
	V <sub>AC2</sub> - AC BUS 2	3.3
	V <sub>F</sub> - FLIGHT BUS	3.2
	V <sub>SMA</sub> - SERVICE MODULE BUS A	3.2
	V <sub>SMB</sub> - SERVICE MODULE BUS B	3.2

1.8.5.2

Sequential buses.-

		<u>Prime CSH generation dwg No.</u>
✓	SQA - SEQUENTIAL PYRO BUS A	2.2
✓	RQA - RCS CONTROLLER PYRO BUS A	2.2
✓	RLA - RCS CONTROLLER LOGIC BUS A	2.2
✓	SLA - SEQUENTIAL LOGIC BUS A	2.2
✓	SAA - SEQUENTIAL ARM BUS A	2.2
✓	ELA - EARTH LANDING BUS A	2.5
✓	SQB - SEQUENTIAL PYRO BUS B	2.2
✓	RQB - RCS CONTROLLER PYRO BUS B	2.2
✓	RLB - RCS CONTROLLER LOGIC BUS B	2.2
✓	SLB - SEQUENTIAL LOGIC BUS B	2.2
✓	SAB - SEQUENTIAL ARM BUS B	2.2
✓	ELB - EARTH LANDING BUS B	2.5
✓	ED 1 - EMERGENCY DETECTION SYSTEM BUS NO 1	2.3
✓	ED 2 - EMERGENCY DETECTION SYSTEM BUS NO 2	2.3

Sequential buses (cont'd) .-

Prime CSH  
generation  
dwg No .

V	ED 3	- EMERGENCY DETECTION SYSTEM BUS NO 3	2.3
V	6D95	- IU ABORT BUS	2.3

1.8.5.3

Instrumentation buses .-

V	1	- CM ESS INST BUS PWR FROM RHEB PNL 276-CB1	7.1
V	2	- CM ESS INST BUS PWR FROM RHEB PNL 276-CB2	7.1
V	3S	- SM ESS INST BUS PWR FROM RHEB PNL 276-CB3	7.1
V	4S	-SM ESS INST BUS PWR FROM RHEB PNL 276-CB4	7.1
V	SC	- SCE PWR REQ'D FOR SIGNAL CONDITIONING (+20, -20, and/or +10Vdc)	7.1 and Page 7-18
V	SC5	- SCE CM +5Vdc PWR	7.1
V	RCS	- SM RCS INDICATOR BUS POWER FROM SM MAIN BUS	10.2
V	RCS	- SM RCS INDICATOR BUS POWER FROM SM MAIN BUS	10.2

1.8.5.4

SCS logic buses .-

✓ LB1 - LOGIC BUS 1

✓ LB2 - LOGIC BUS 2

✓ LB3 - LOGIC BUS 3

✓ LB4 - LOGIC BUS 4

Prime CSH  
generation  
dwg No .

8.2

8.2

8.2

8.2

2 SEQUENTIAL  
EVENTS SYSTEM

1

2

3

4

5

6



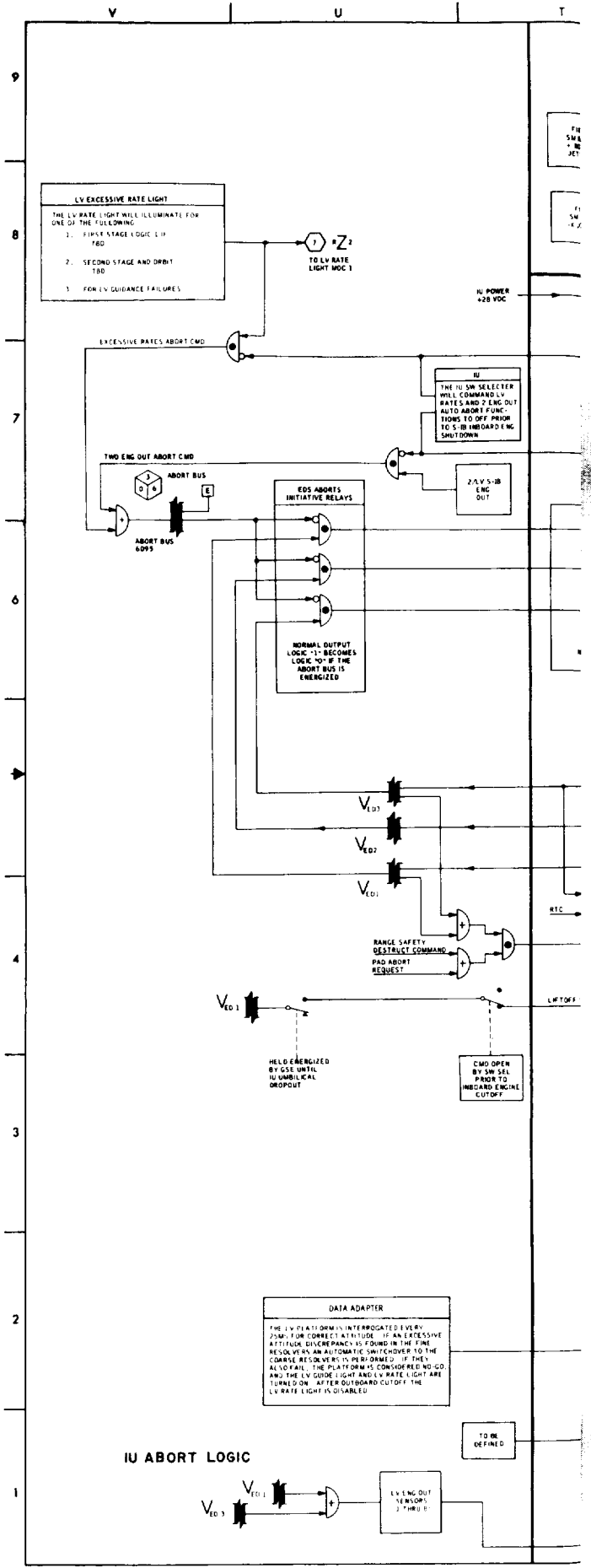

**FOLDOUT FRAME**



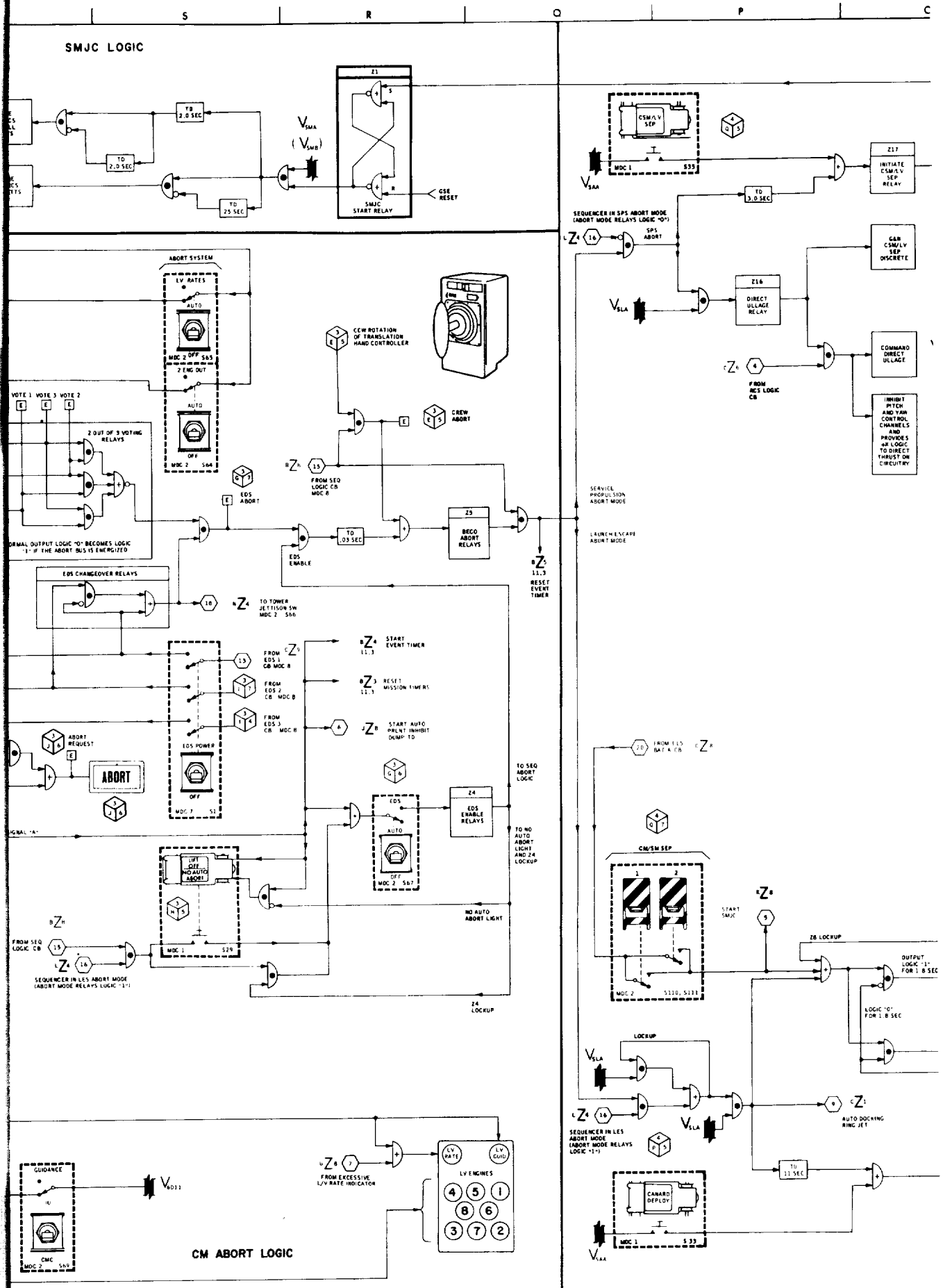



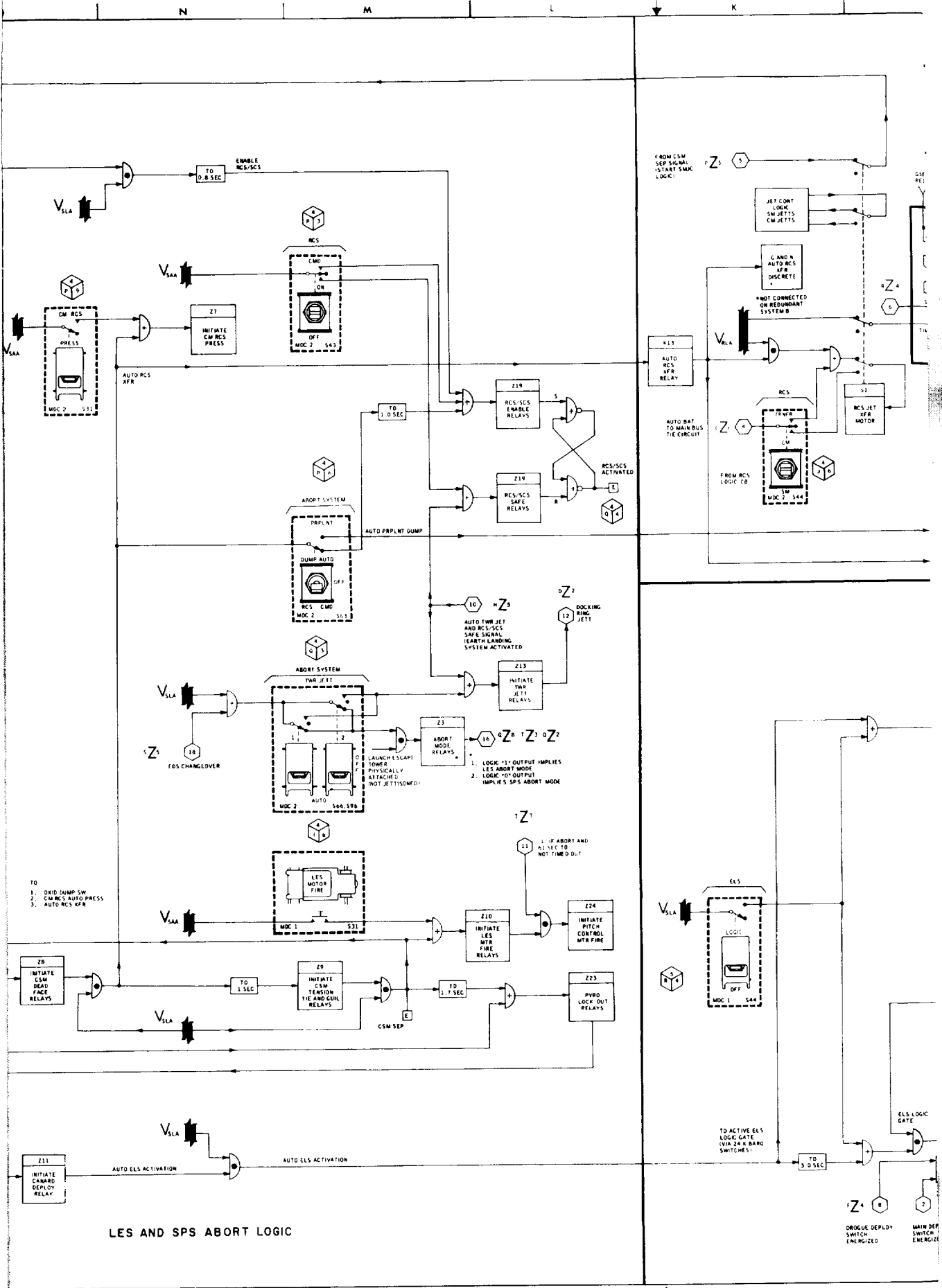

LES AND SPS ABORT LOGIC



RCSC LOGIC

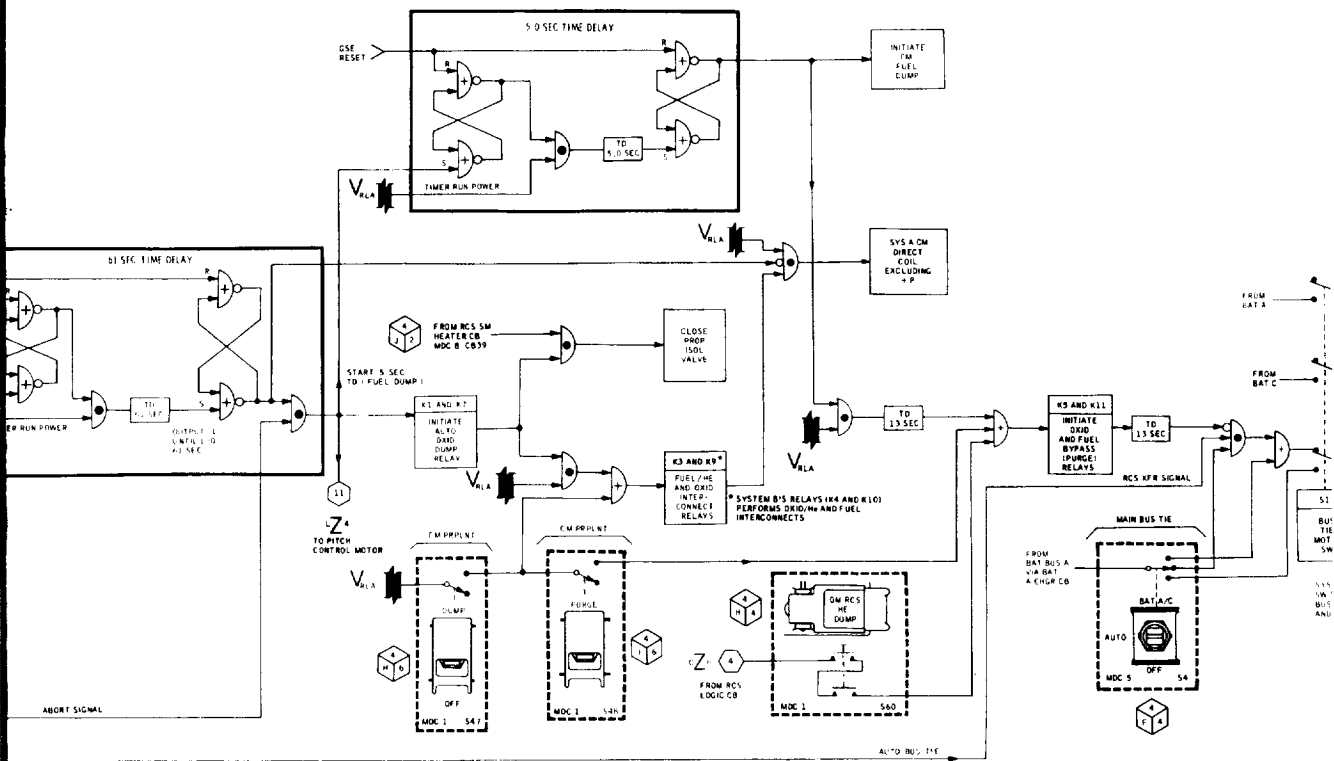

ELS LOGIC

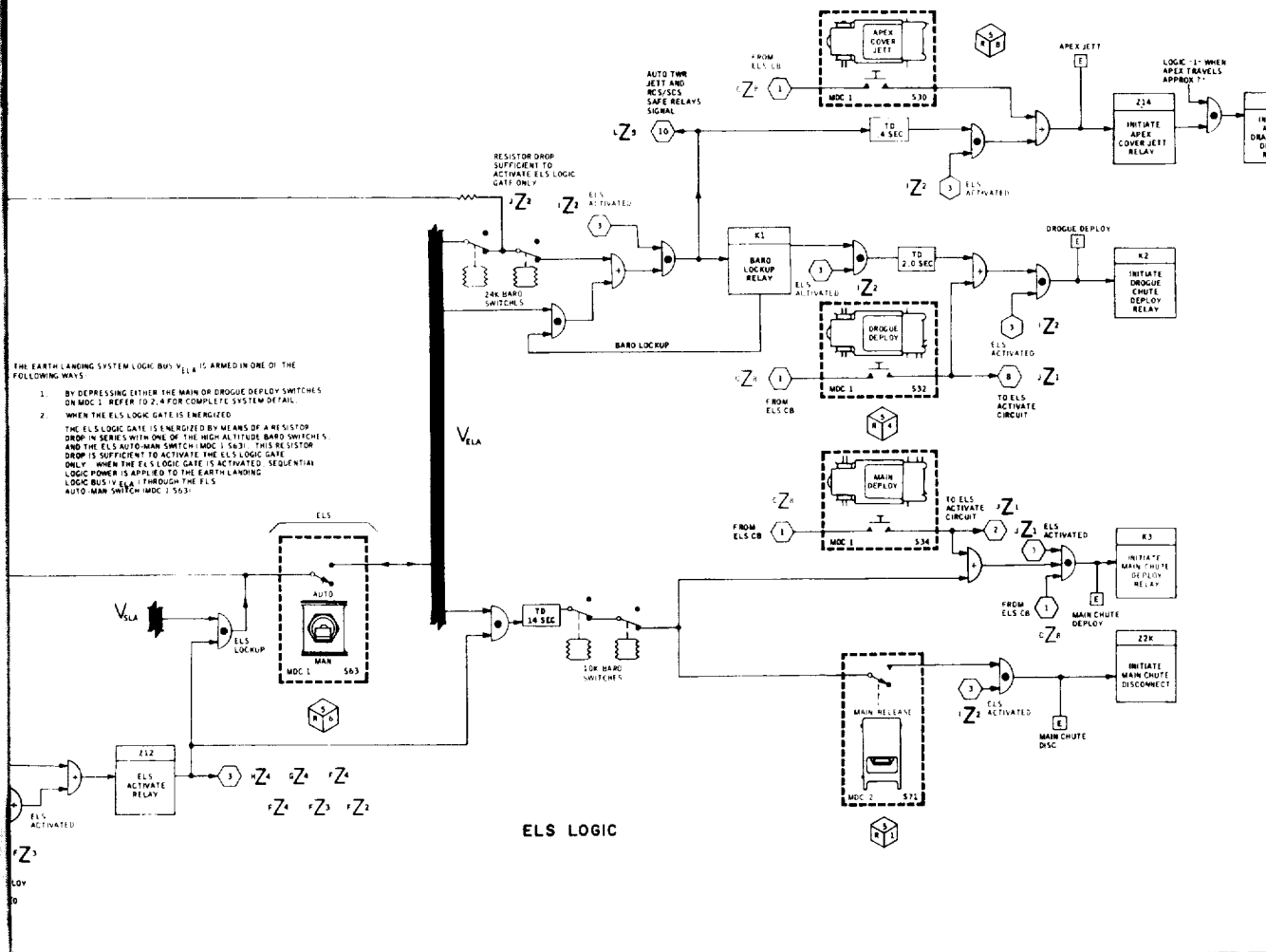

THE EARTH LANDING SYSTEM LOGIC BUS V<sub>ELA</sub> IS ARMED IN ONE OF THE FOLLOWING WAYS:

1. BY DEPRESSING EITHER THE MAIN OR DROGUE DEPLOY SWITCHES ON MDC 1. REFER TO 2.4 FOR COMPLETE SYSTEM DETAIL.
2. WHEN THE ELS LOGIC GATE IS ENERGIZED.

THE ELS LOGIC GATE IS ENERGIZED BY MEANS OF A RESISTOR DROP IN SERIES WITH ONE OF THE HIGH ALTITUDE BARO SWITCHES AND THE ELS AUTO MAIN SWITCH (MDC 1 S63). THIS SYSTEM DROP IS SUFFICIENT TO ACTIVATE THE ELS LOGIC GATE ONLY WHEN THE ELS LOGIC GATE IS ACTIVATED. SEQUENTIAL LOGIC POWER IS APPLIED TO THE EARTH LANDING LOGIC BUS V<sub>ELA</sub> THROUGH THE ELS AUTO MAIN SWITCH (MDC 1 S63).





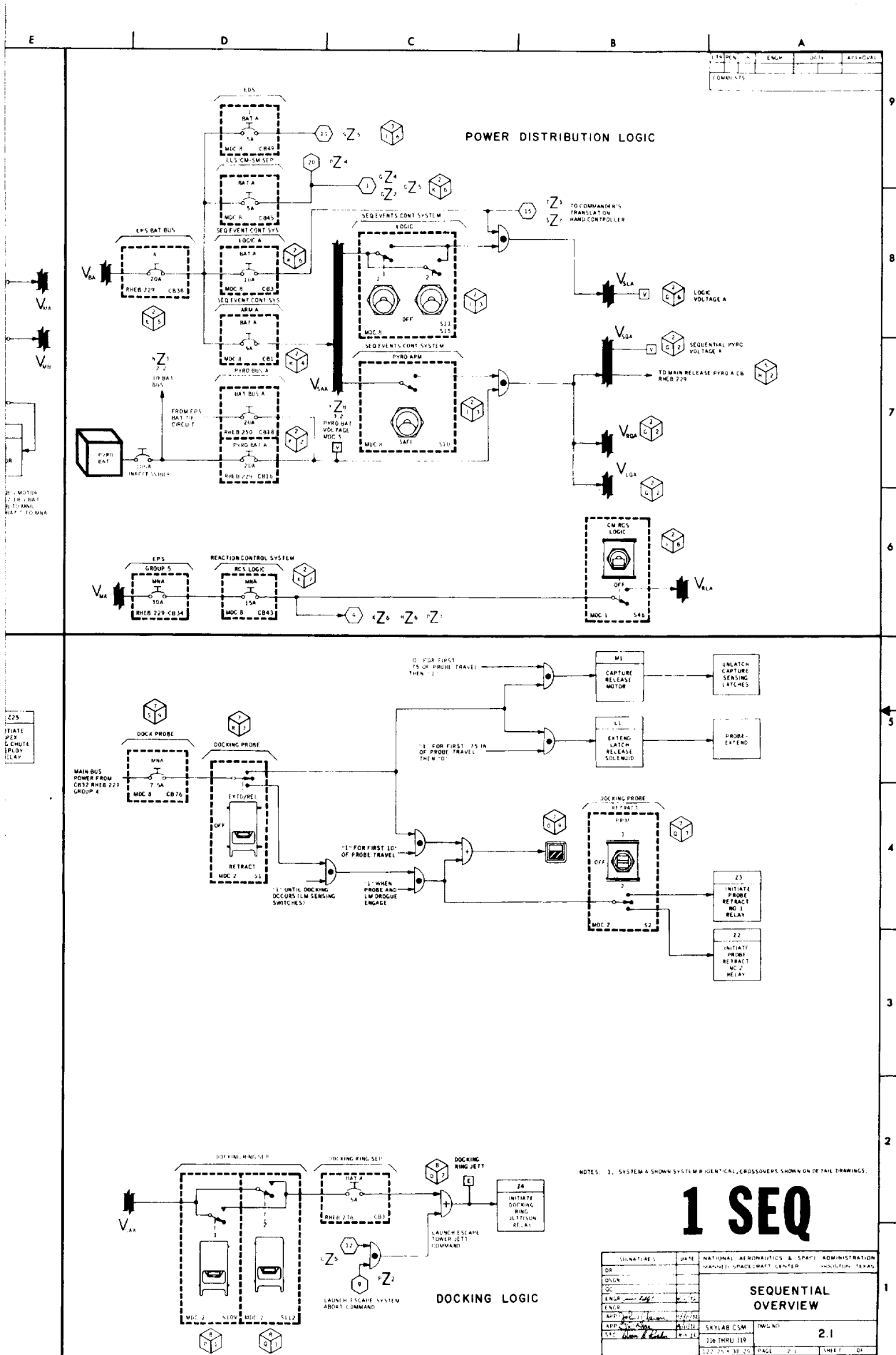

# 1 SEQ

NOTES: 1. SYSTEM AS SHOWN SYSTEM IDENTICAL, CROSSOVERS SHOWN ON DETAIL DRAWINGS.

SIGNATURE	DATE	NATIONAL AERONAUTICS & SPACE ADMINISTRATION
DR		MANNED SPACEFLIGHT CENTER HOUSTON, TEXAS
QC		
ENGR		
APP		
ESC		
SKYLARK CSM		FWG NO
110 THRU 119		2.1
110 THRU 119	PAGE 2	SHEET 04



8

7

6

5

4

3

2

1



**FOLDOUT FRAME |**

1000

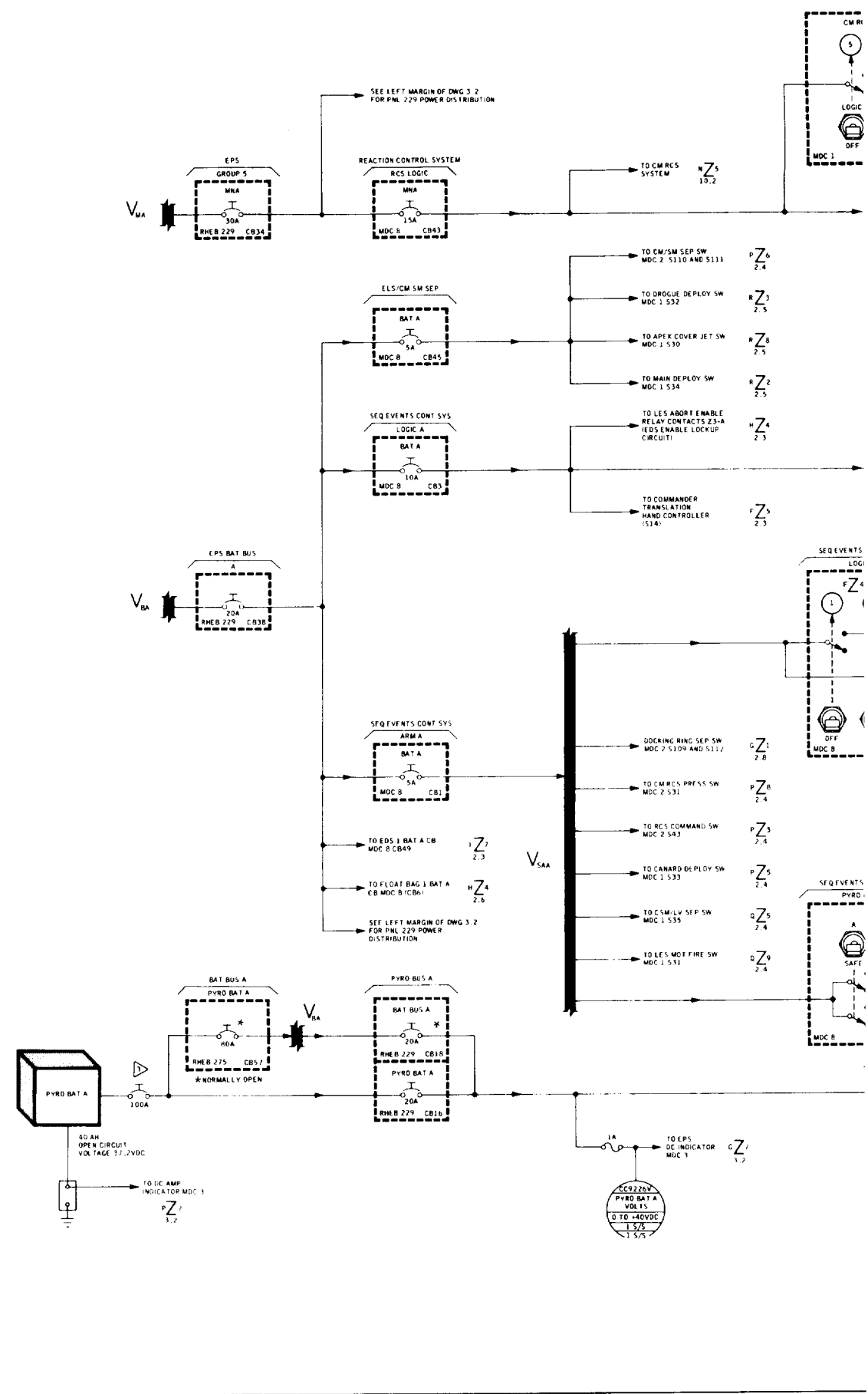



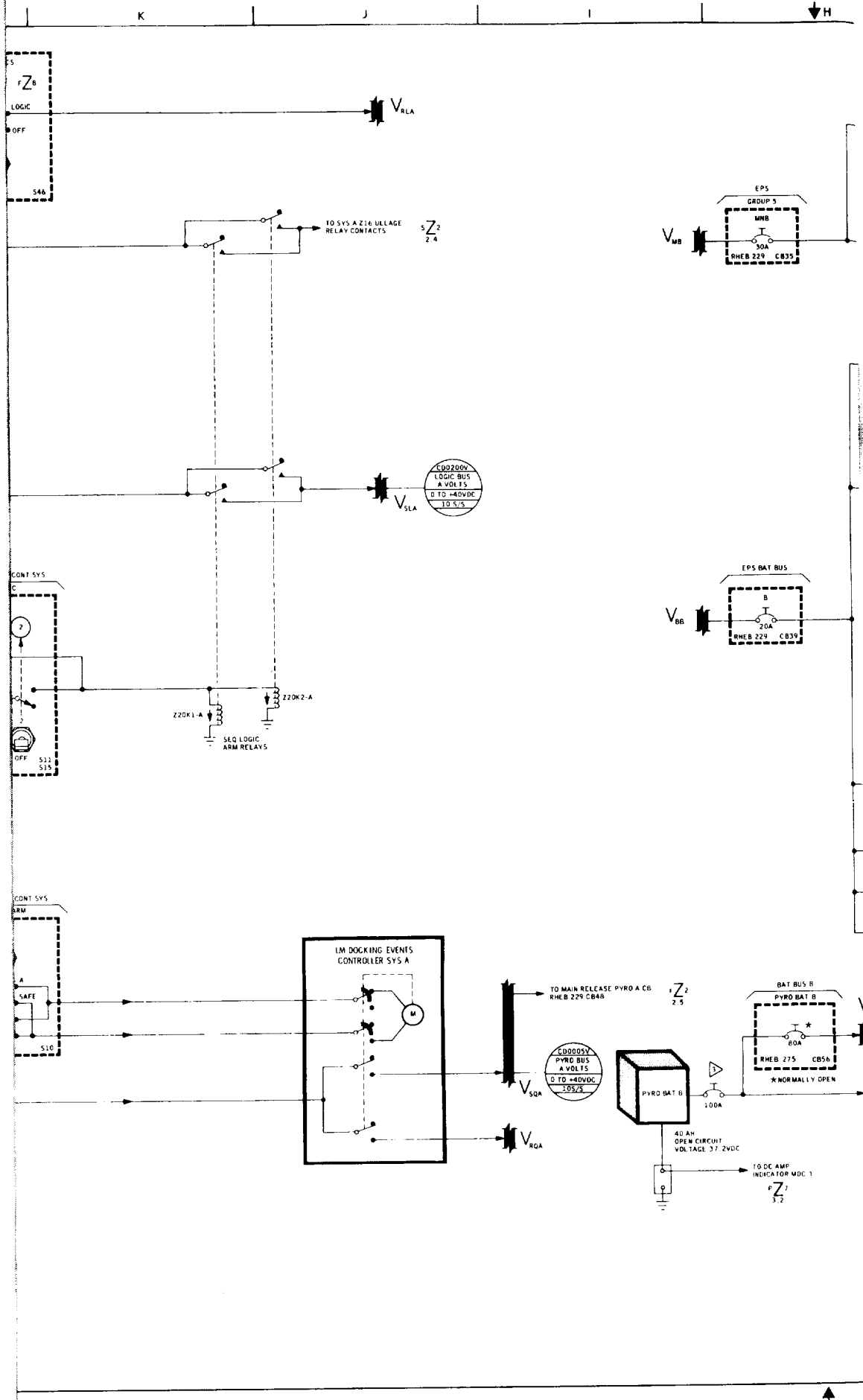

FOLDOUT FRAME 3





G

F

E

SEE LEFT MARGIN OF DWG 3.2 FOR PNL 229 POWER DISTRIBUTION

REACTION CONTROL SYSTEM

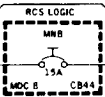

TO CM RCS SYSTEM  
N Z 4  
10.2

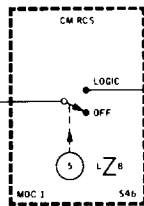

EIS/CM SW SEP

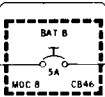

TO CM/SM SEP SW  
MDC 2 5110 AND 5111  
P Z 6  
2.4

TO DROGUE DEPLOY SW  
MDC 1 532

TO APEX COVER JET SW  
MDC 1 530

TO MAIN DEPLOY SW  
MDC 1 534

SEQ EVENTS CONT SYS

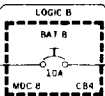

TO LES ABORT ENABLE RELAY CONTACTS 23-B (EDS ENABLE LOCKUP CIRCUIT)

TO COMMANDER TRANSLATION HAND CONTROLLER (5151)  
E Z 5  
2.3

SEQ EVENTS CONT SYS

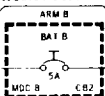

DOCKING RING SEP SW  
MDC 2 5109 AND 5112  
N Z 1  
2.7

TO RCS COMMAND SW  
MDC 2 143  
P Z 3  
2.4

TO CM RCS PRESS SW  
MDC 2 531  
P Z 9  
2.4

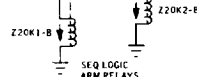
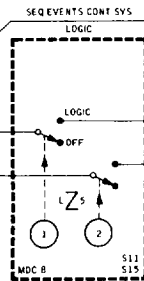

V<sub>SAB</sub>

TO LHS BAT B CH  
MDC H CB51  
I Z 3  
2.3

TO FLOAT BAG 2 BAT B  
CB MDC B (CB7)  
H Z 6  
2.6

SEE LEFT MARGIN OF DWG 3.2 FOR PNL 229 POWER DISTRIBUTION

PYRO BUS B

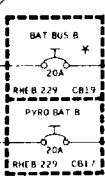

TO CANARD DEPLOY SW  
MDC 1 533  
P Z 5  
2.4

TO OSM/LV SEP SW  
MDC 1 535  
Q Z 5  
2.4

TO LES MOT FIRE SW  
MDC 531  
Q Z 9  
2.4

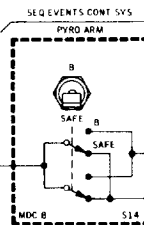

TO EPS DC INDICATOR  
MDC 3  
G Z 6  
3.2



FOLDOUT FRAME 4

.....

LTN	PCR	DR	ENGR	DATE	APPROVAL
COMMENTS					

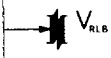

YS B 216 ULLAGE  
BY CONTACTS

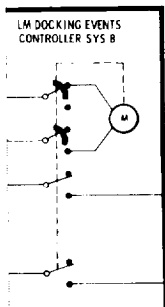
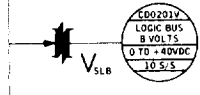

TO MAIN RELEASE PYRO R CB  
RHEB 229 CB49 (SYS B NOT SHOWN)

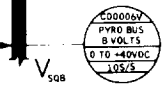

▷ INACCESSIBLE CIRCUIT BREAKERS

- V\_ELA EARTH LANDING BUS A
- V\_ELB EARTH LANDING BUS B
- V\_RQA REACTION CONTROL SYSTEM CONTROLLER PYRO BUS A
- V\_RQB REACTION CONTROL SYSTEM CONTROLLER PYRO BUS B
- V\_LLA REACTION CONTROL SYSTEM CONTROLLER LOGIC BUS A
- V\_RLB REACTION CONTROL SYSTEM CONTROLLER LOGIC BUS B
- V\_SLA SEQUENTIAL LOGIC BUS A
- V\_SLB SEQUENTIAL LOGIC BUS B
- V\_SAA SEQUENTIAL ARM BUS A
- V\_SAB SEQUENTIAL ARM BUS B

NOTES: 1. THIS DRAWING SHOWS ARMING OF SYSTEM A AND SYSTEM B OF THE SEQUENTIAL EVENT CONTROL SYSTEM. IN GENERAL, OTHER DRAWINGS IN THIS SECTION SHOW ONLY SYSTEM A WITH APPROPRIATE SYSTEM B CROSSOVERS.

# 2 SEQ PWR

SIGNATURES		DATE	NATIONAL AERONAUTICS & SPACE ADMINISTRATION MANNED SPACECRAFT CENTER - HOUSTON, TEXAS	
DR	<i>James J. ...</i>	1/17/71	<b>SEQUENTIAL POWER DISTRIBUTION</b>	
DC				
ENGR	<i>James J. ...</i>	1/17/71		
ENGR				
APP	<i>James J. ...</i>	1/17/71	SKYLAB CSM	2.2
APP	<i>James J. ...</i>	1/17/71	116 THRU 119	
STC	<i>James J. ...</i>	1/17/71	82.5 X 34	
			PAGE 2-2	SHEET 1 OF 1



EOLDOUT FRAME /



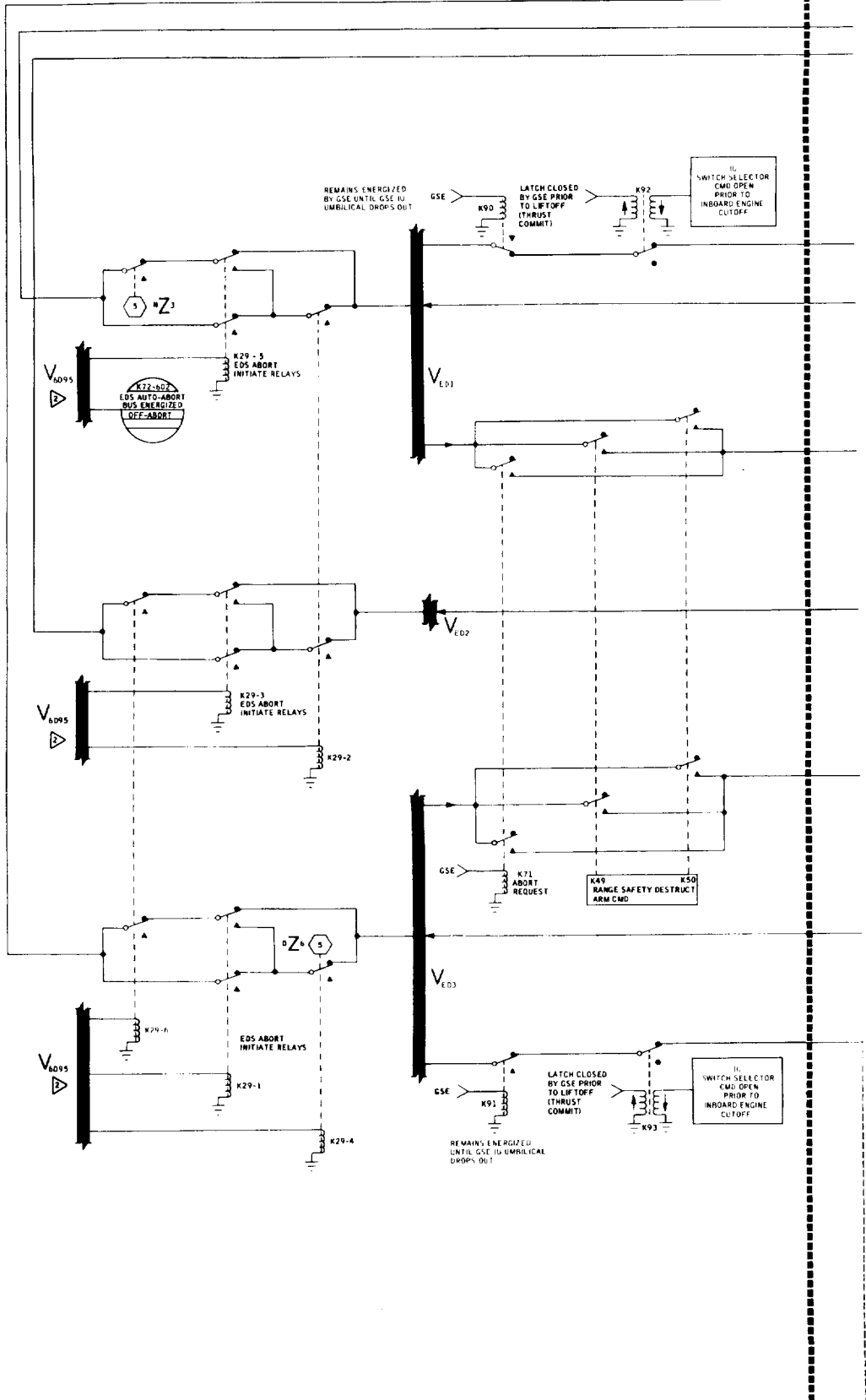





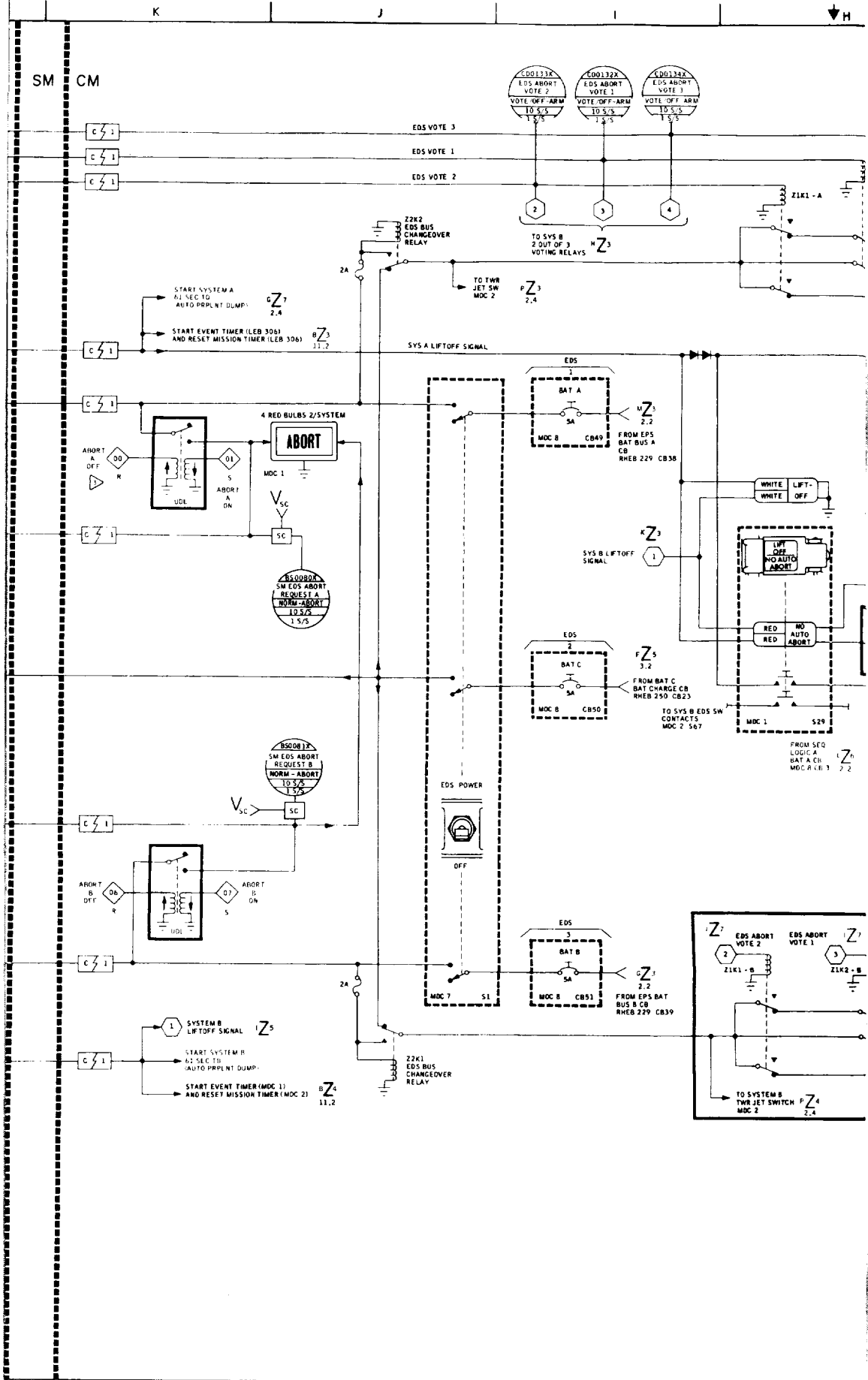

1  
2  
3  
4  
5  
6  
7  
8  
9  
10  
11  
12  
13  
14  
15  
16  
17  
18  
19  
20  
21  
22  
23  
24  
25  
26  
27  
28  
29  
30  
31  
32  
33  
34  
35  
36  
37  
38  
39  
40  
41  
42  
43  
44  
45  
46  
47  
48  
49  
50  
51  
52  
53  
54  
55  
56  
57  
58  
59  
60  
61  
62  
63  
64  
65  
66  
67  
68  
69  
70  
71  
72  
73  
74  
75  
76  
77  
78  
79  
80  
81  
82  
83  
84  
85  
86  
87  
88  
89  
90  
91  
92  
93  
94  
95  
96  
97  
98  
99  
100

G

F

E

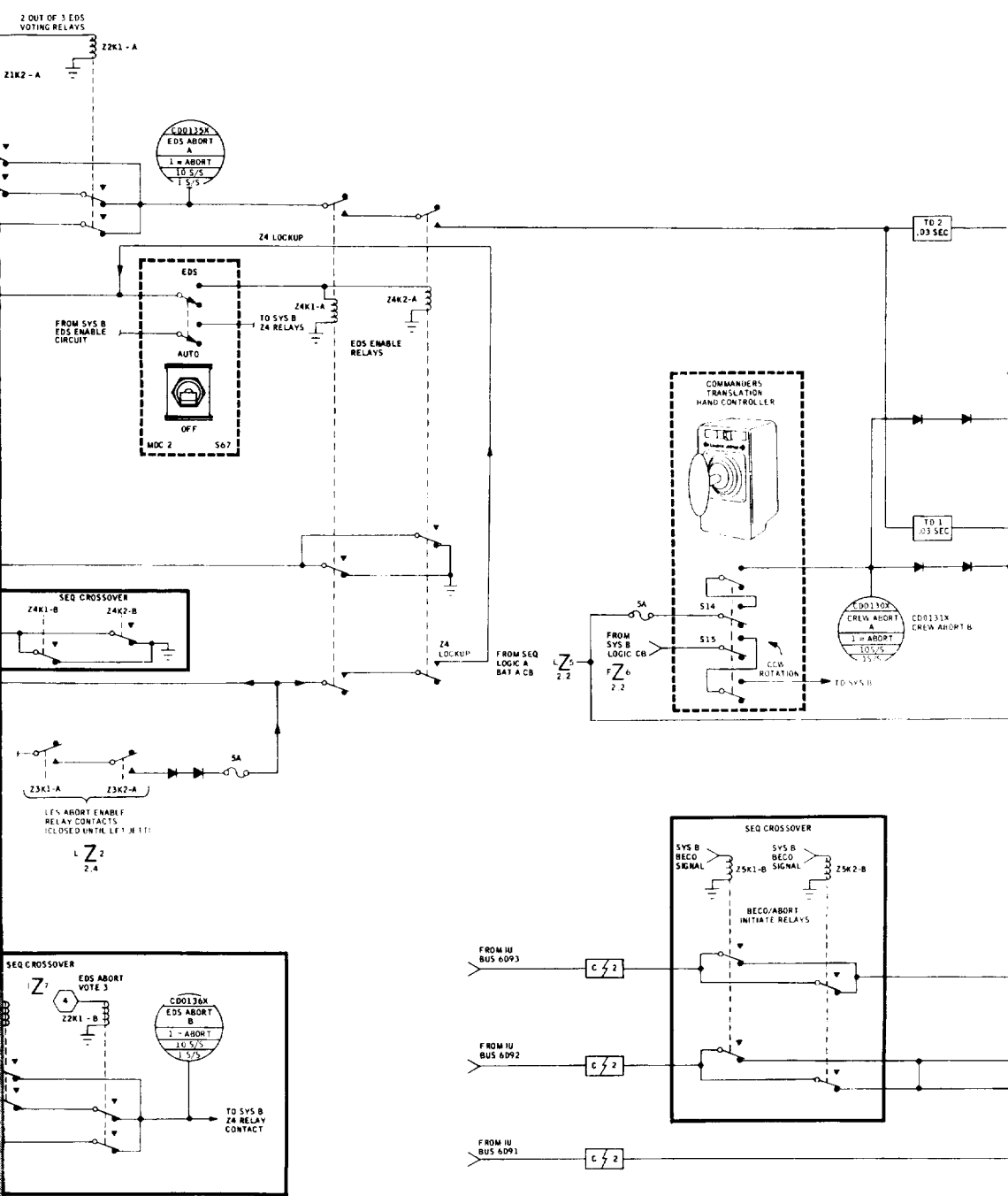



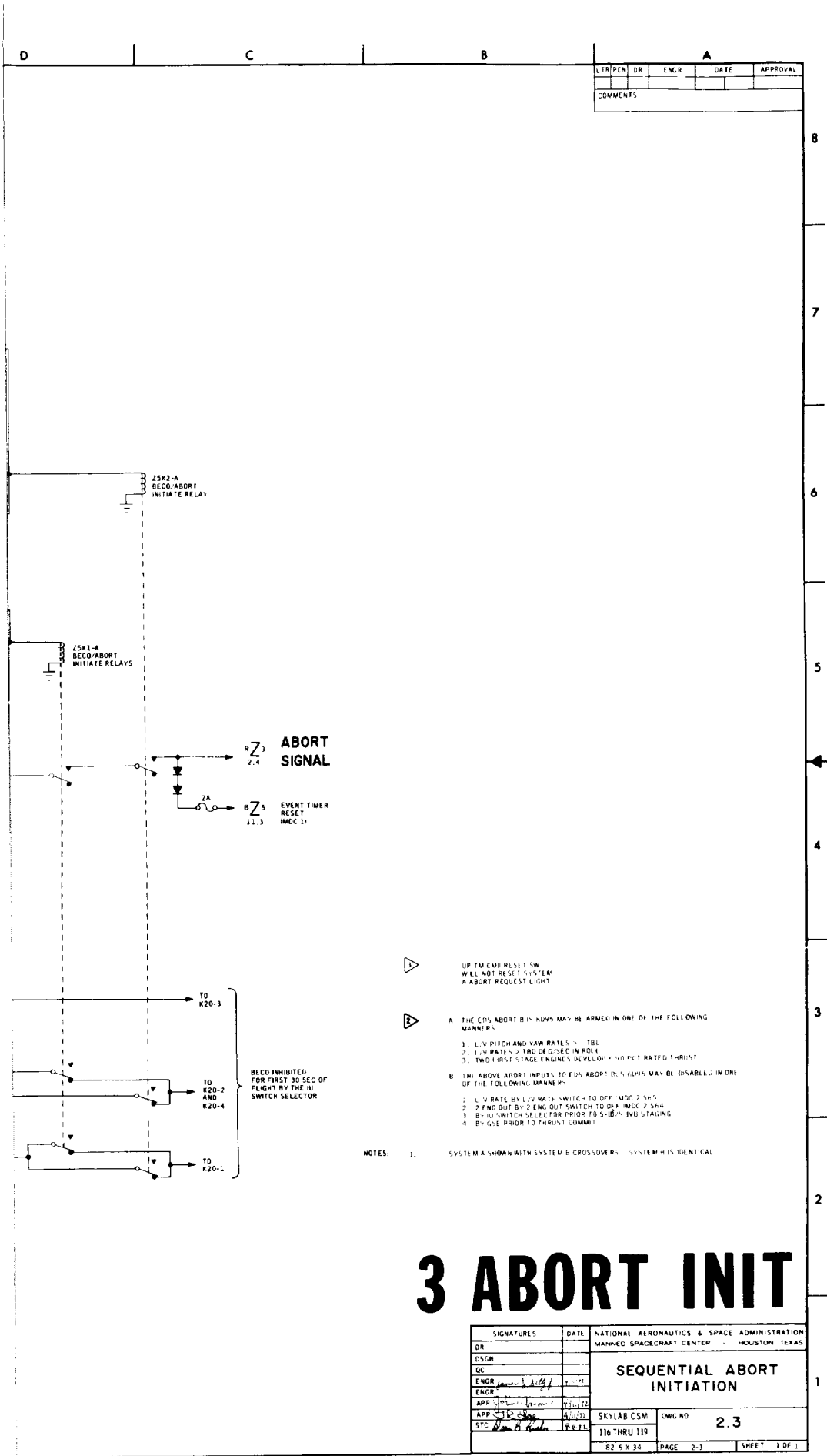

LTR/PCN	DR	ENGR	DATE	APPROVAL
COMMENTS				

8  
7  
6  
5  
4  
3  
2

**ABORT SIGNAL**  
Z 2.4

**EVENT TIMER RESET**  
Z 11.3

BECO INHIBITED FOR FIRST 30 SEC OF FLIGHT BY THE IU SWITCH SELECTOR

- ▽ UP TM ENR RESET SW WILL NOT RESET SYSTEM A ABORT REQUEST LIGHT
- ▽ A THE CIV ABORT BUS AIDS MAY BE ARMED IN ONE OF THE FOLLOWING MANNERS:
  1. L/V PITCH AND YAW RATES > TBU
  2. L/V RATES > TBU DEG/SEC IN ROL
  3. TWO FIRST STAGE ENGINE'S DEVELOP > 400 PCT RATED THRUST
- B THE ABOVE ABORT INPUTS TO CIV ABORT BUS AIDS MAY BE DISABLED IN ONE OF THE FOLLOWING MANNERS:
  1. L/V RATE BY L/V RATE SWITCH TO OFF, IMDC 2 565
  2. 2 ENG OUT BY 2 ENG OUT SWITCH TO DEF, IMDC 2 565
  3. BY IU SWITCH SELEC FOR PRIOR TO S-IB/4 IWB STAGING
  4. BY USE PRIOR TO THRUST COMMT

NOTES: 1. SYSTEM A SHOWN WITH SYSTEM B CROSSOVERS. SYSTEM B IS IDENTICAL

# 3 ABORT INIT

SIGNATURES	DATE	NATIONAL AERONAUTICS & SPACE ADMINISTRATION MANNED SPACECRAFT CENTER HOUSTON, TEXAS	
DR		<b>SEQUENTIAL ABORT INITIATION</b>	
DSGN			
DC			
ENGR			
ENGR			
APP		SKYLAB CSM	OWC NO
APP		116 THRU 119	2.3
STC		82 5 X 34	PAGE 2-3 SHEET 3 OF 1

**FOLDOUT FRAME 5**



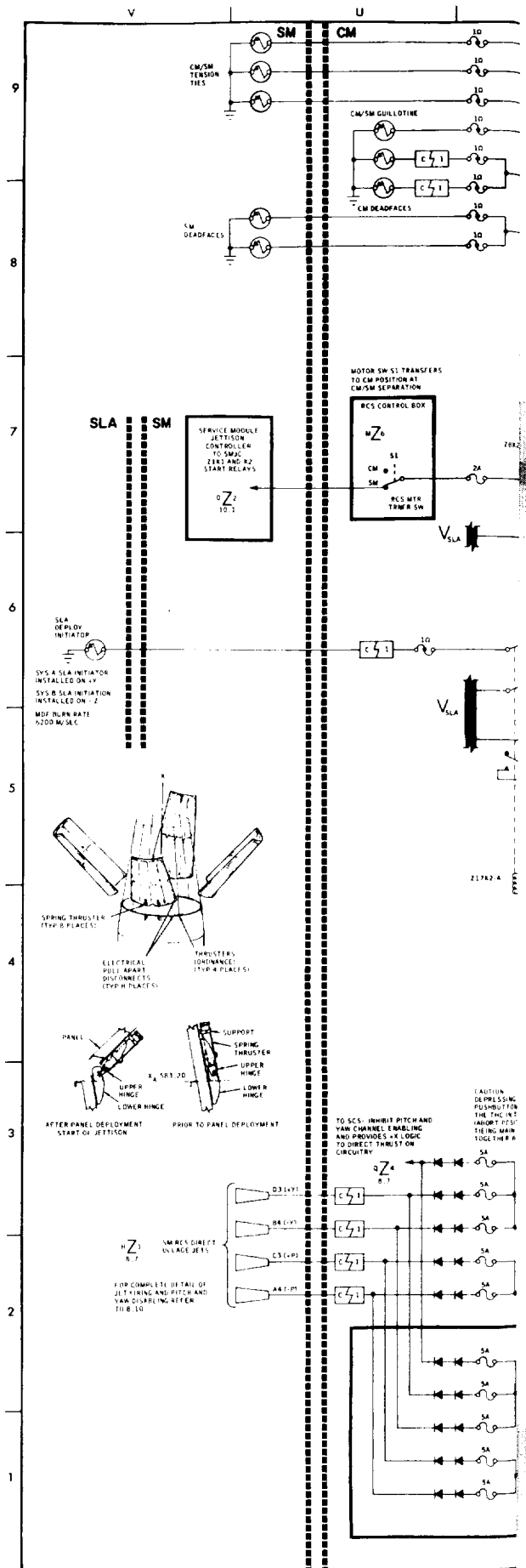

**FOLDOUT FRAME 1**





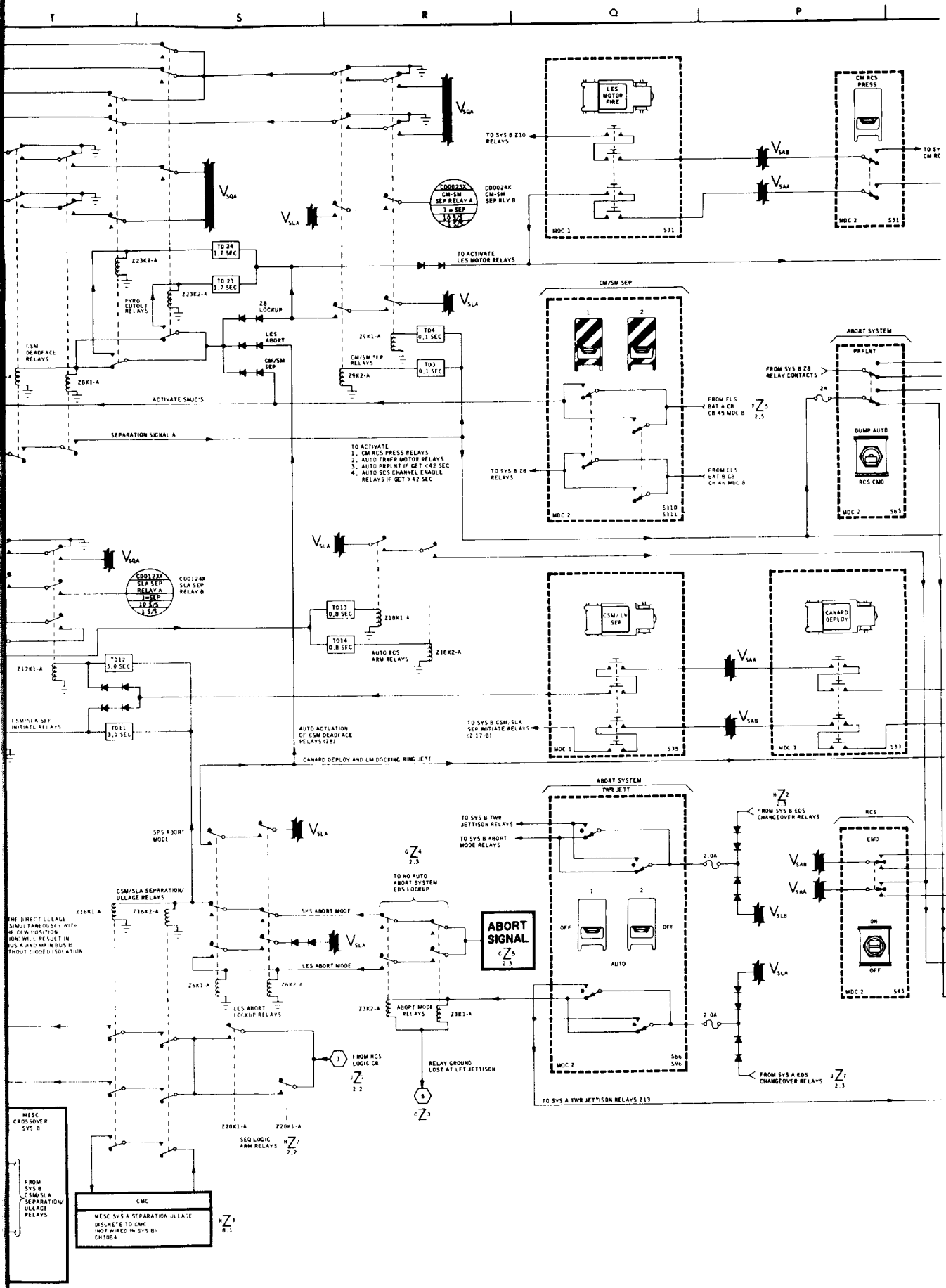

FOLDOUT FRAME 2





10/10/19

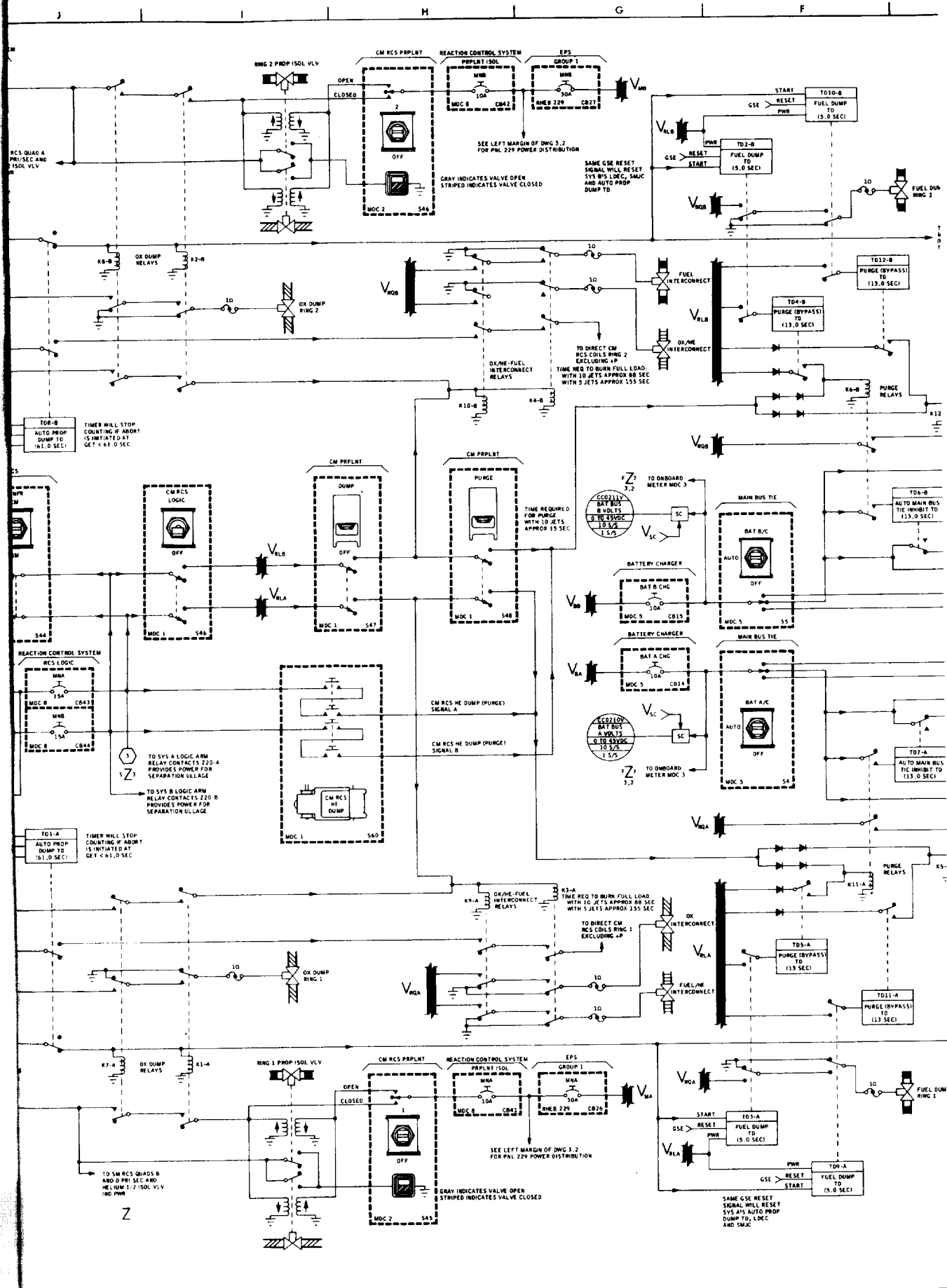

FOLDOUT FRAME 4



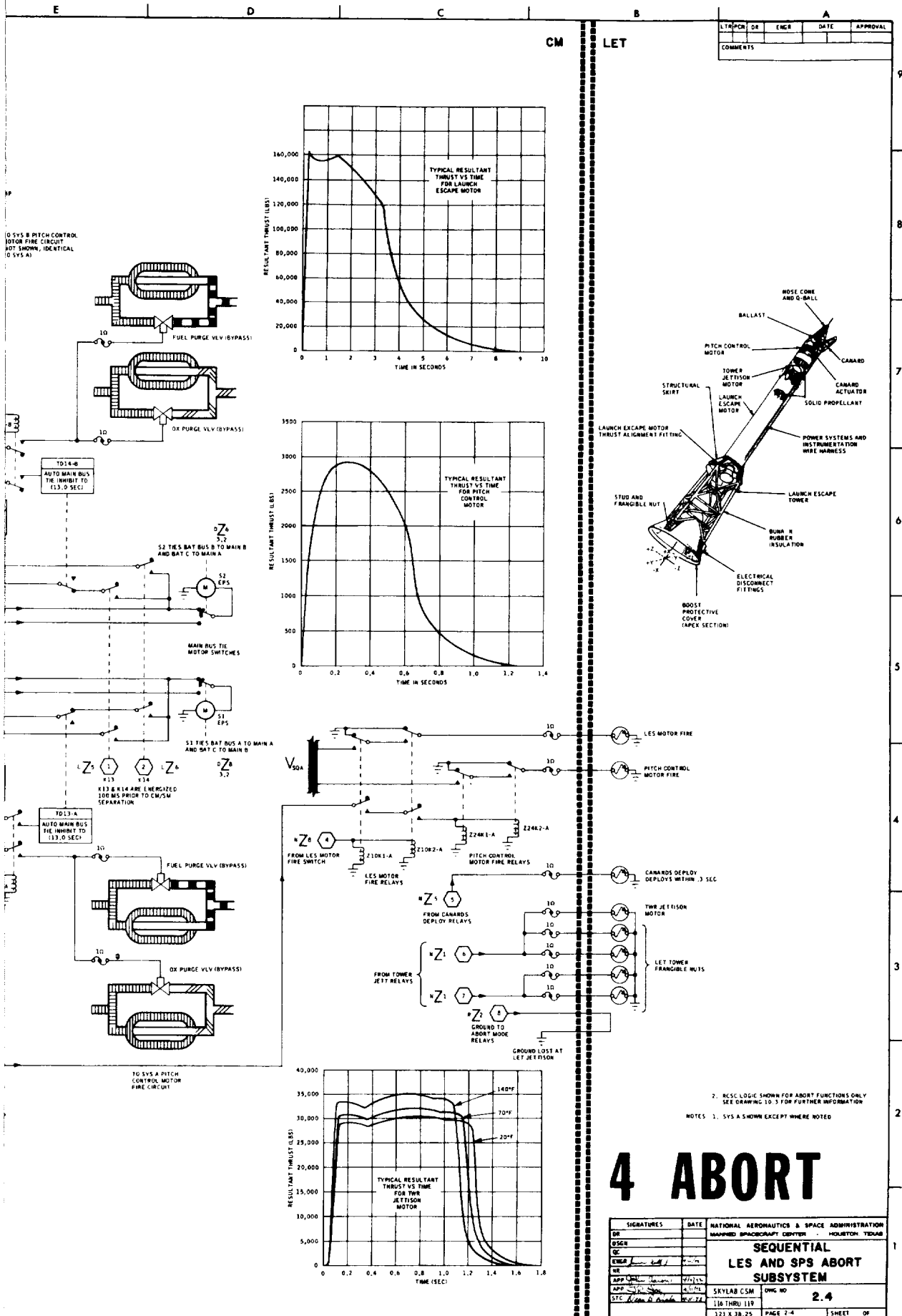

LT/PC/DR	EMER	DATE	APPROVAL

COMMENTS

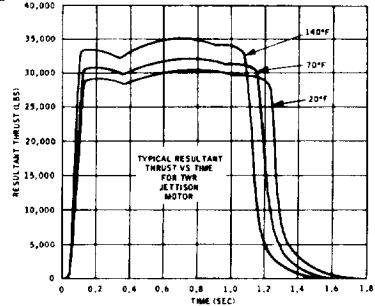
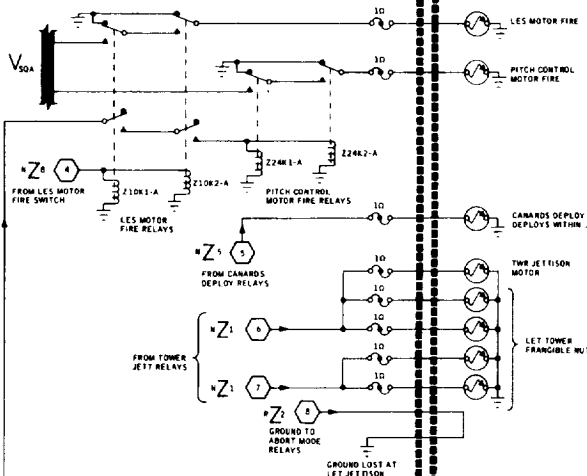
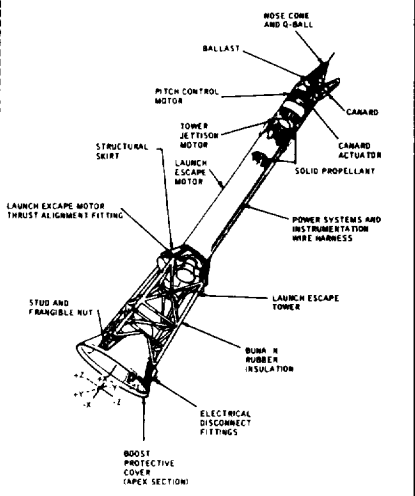
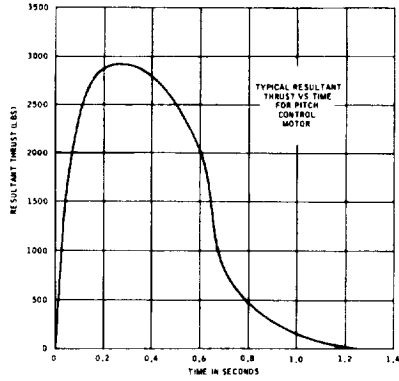
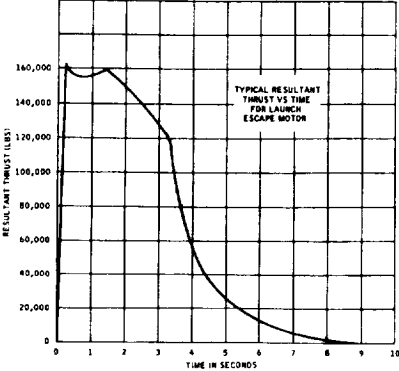

2. RECL LOGIC SHOWN FOR ABORT FUNCTIONS ONLY SEE DRAWING 10-3 FOR FURTHER INFORMATION  
 NOTES 1. SYS A SHOWN EXCEPT WHERE NOTED

# 4 ABORT

SIGNATURES	DATE	NATIONAL AERONAUTICS & SPACE ADMINISTRATION
DR		MANHATTAN SPACECRAFT CENTER HOUSTON TEXAS
EMER		
SR		
APP		
DR		
STC		

SEQUENTIAL  
 LES AND SPS ABORT  
 SUBSYSTEM  
 SKYLAB CSM DMC NO  
 116 THRU 119  
 121 X 38-25 PAGE 2-4 SHEET OF





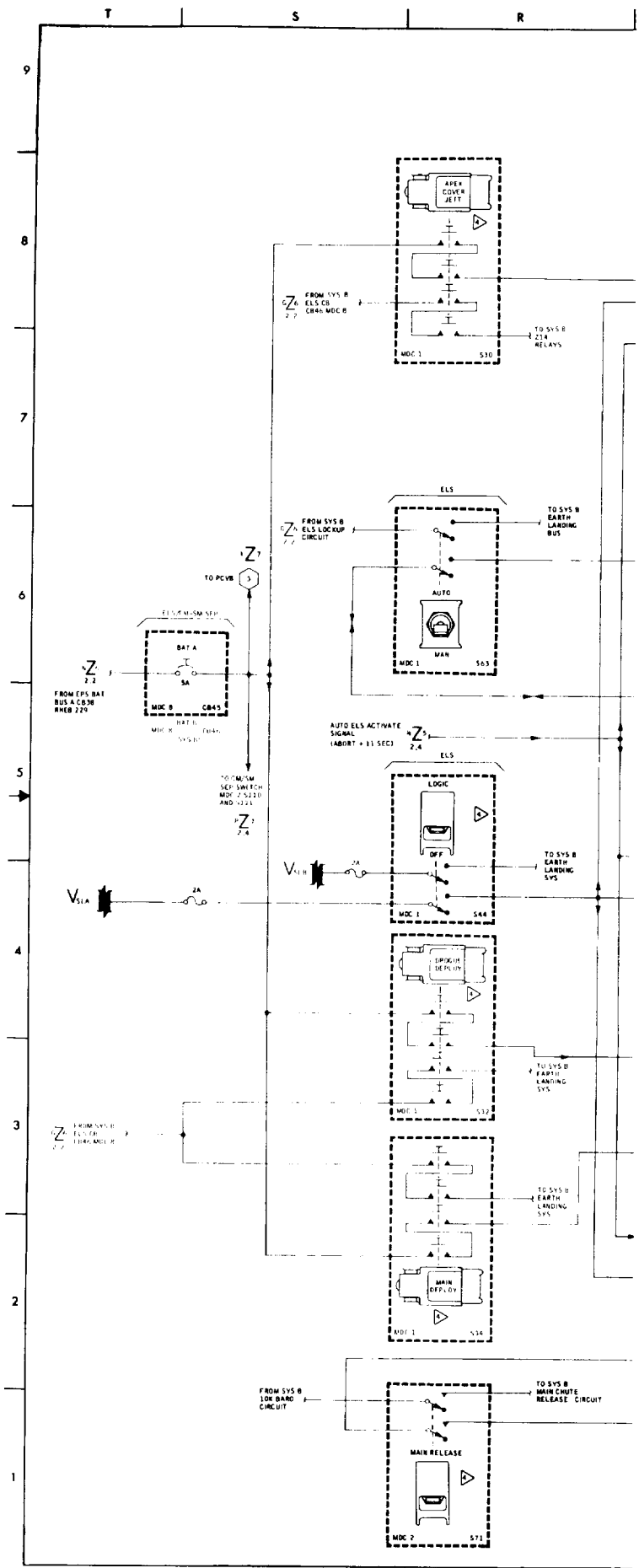

**EQLDOUT FRAME**



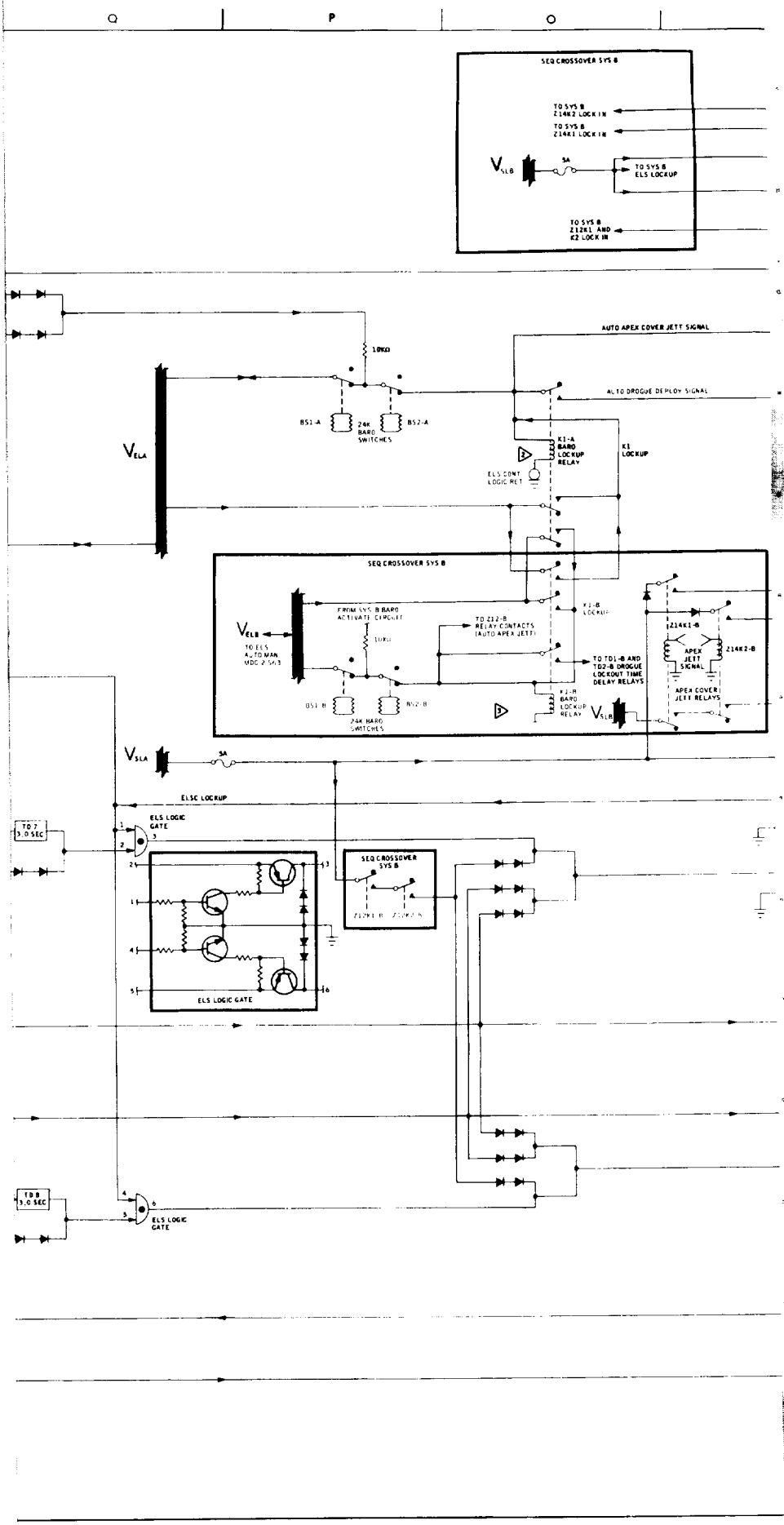



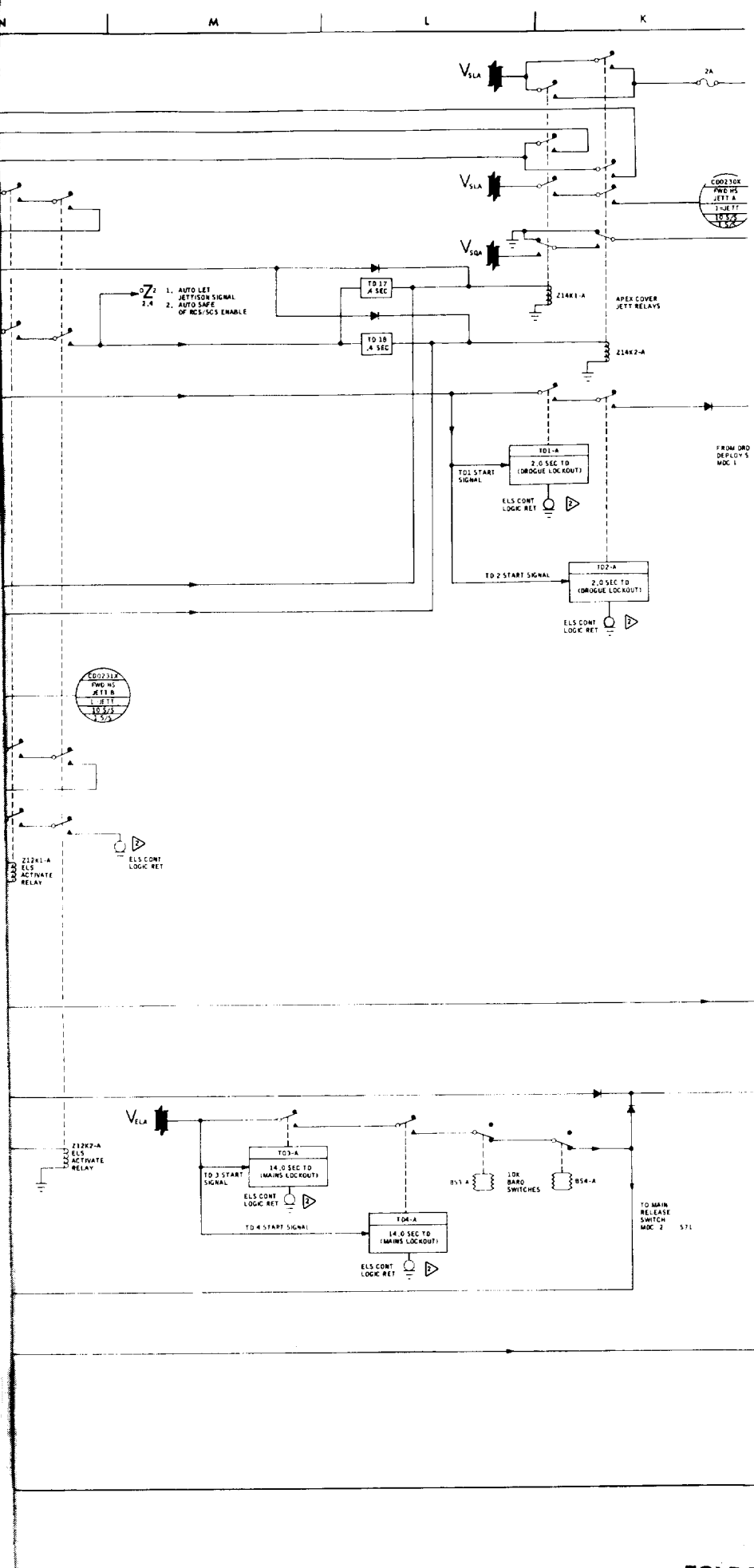

2023年12月27日











DATE	OR	ENGR	DATE	APPROVAL
COMMENTS				

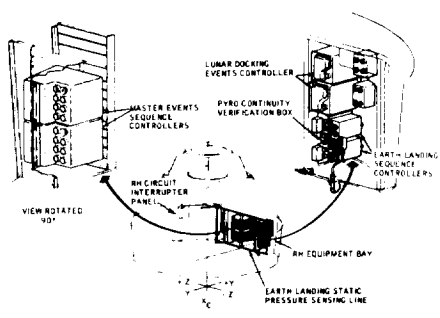
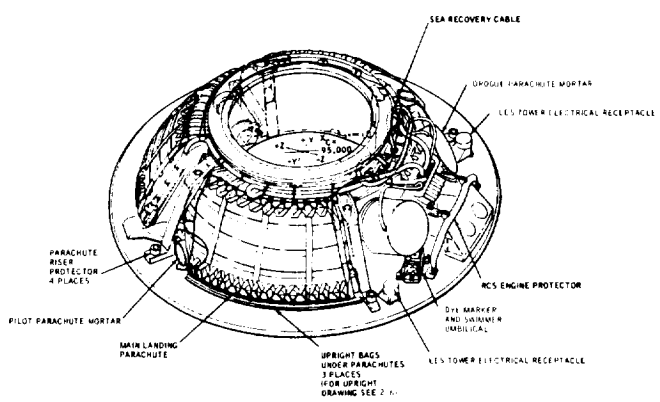

- ▷ SWITCH LOCATED UNDER PROTECTIVE COVER
  - ▷ RELAYS WILL NOT BE GROUNDED UNTIL ELS ACTIVATED RELAYS 222/5/5/5/5 ARE ENERGIZED
  - ▷ RELAYS WILL NOT BE GROUNDED UNTIL THE ELS ACTIVATE RELAYS 222/5/5/5/5 ARE ENERGIZED
- NOTES 1 SYSTEM A SHOWN EXCEPT WHERE NOTED. PYRO VERIFICATION BOX SHOWN WITH SYSTEM A FUNCTIONS AND SYSTEM B CROSSOVERS. SYSTEM B MAIN CHUTE RELEASE IDENTICAL TO SYSTEM A.

# 5 EARTH LDG

SIGNATURES	DATE	NATIONAL AERONAUTICS & SPACE ADMINISTRATION MANNED SPACECRAFT CENTER HOUSTON, TEXAS	
DSGR		<b>SEQUENTIAL EARTH LANDING SUBSYSTEM</b>	
QC			
ENGR			
INC			
APP			
STC		SKYLAR CSM	DATE: <b>2.5</b>
		116 THRU 119	
		210 X 38 75	PAGE 2-5 SHEET 1 OF 1

FOLDOUT FRAME 6



L K J

8  
7  
6  
5  
4  
3  
2  
1

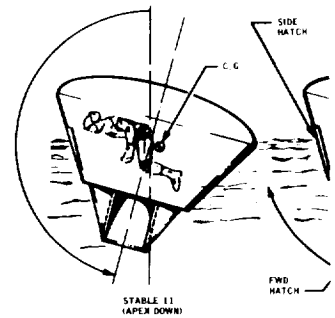
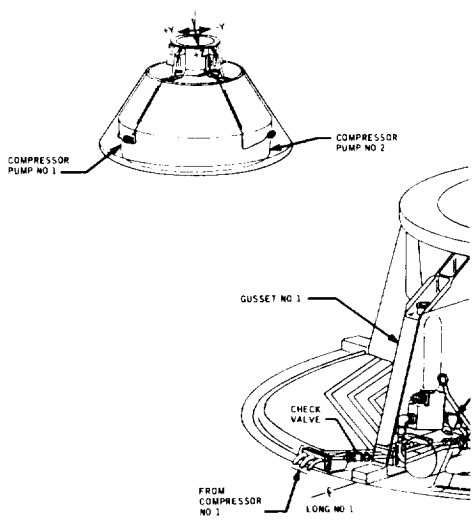

**FOLDOUT FRAME**

10/10/10

H

G

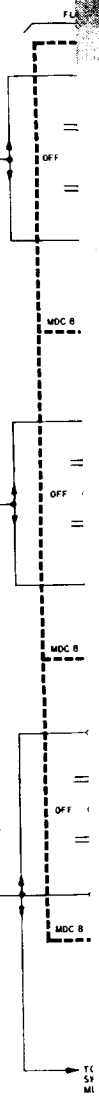
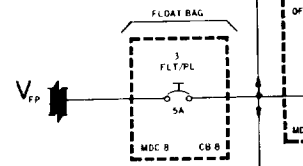
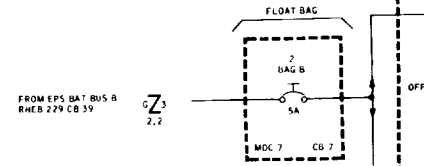
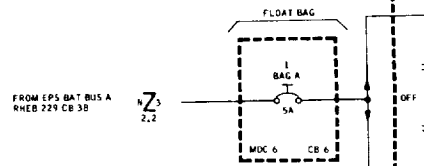
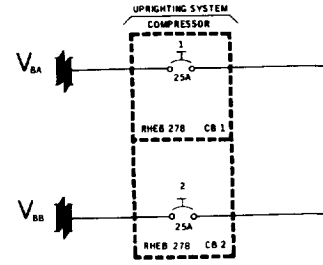
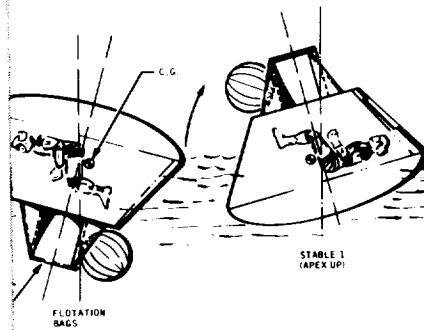
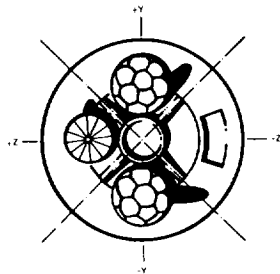
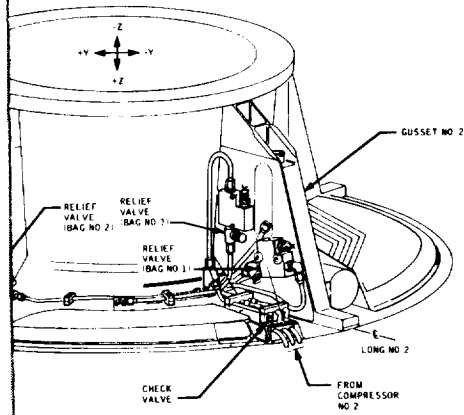

FOLDOUT FRAME 2





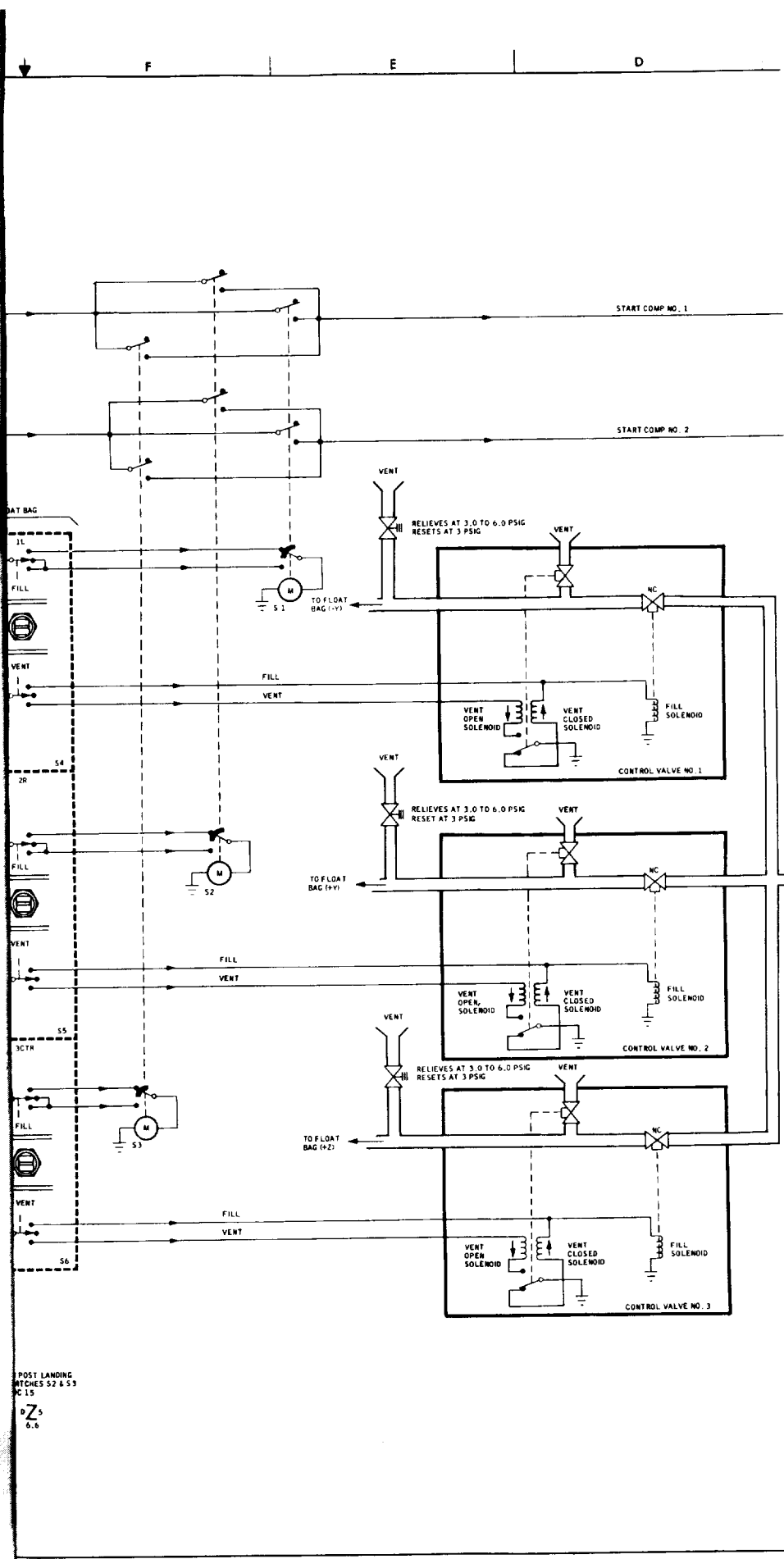

POST LANDING  
LATCHES S2 & S3  
PC 15  
DZ 5  
0.6

FOLDOUT FRAME 3



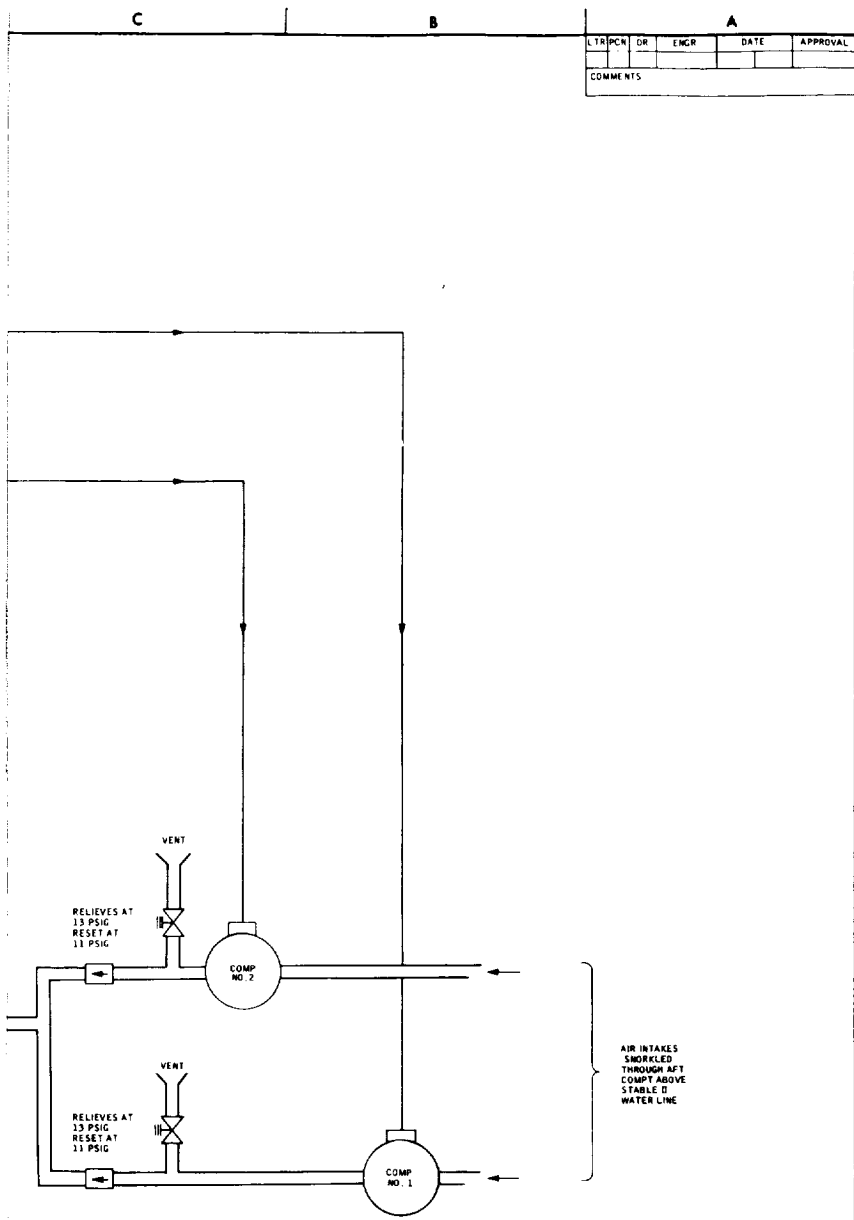

3. APPROXIMATE TIME TO UPRIGHT
  - 1 COMPRESSOR, 3 BAGS - 12 MINUTES
  - 2 COMPRESSOR, 3 BAGS - 5 MINUTES
  - 2 COMPRESSOR, 2 BAGS - 10 MINUTES
2. BAG CAPACITY
  - Y 43 IN DIA @ 24 CUBIC FEET
  - Y 43 IN DIA @ 24 CUBIC FEET
  - Z 34 IN DIA @ 12 CUBIC FEET

NOTES: 1. THIS DRAWING SHOWS BOTH SYSTEM A AND SYSTEM B OF THE COMMAND MODULE UPRIGHTING SYSTEM

# 6 UPRIGHTING

SIGNATURES		DATE	NATIONAL AERONAUTICS & SPACE ADMINISTRATION	
DR	<i>[Signature]</i>	12-2-73	MANNED SPACECRAFT CENTER - HOUSTON TEXAS	
DSCR				
DC				
ENGR	<i>[Signature]</i>	12/1/73	<b>SEQUENTIAL UPRIGHTING SYSTEM</b>	
APP	<i>[Signature]</i>	12/1/73		
APR	<i>[Signature]</i>	12/1/73		
STC	<i>[Signature]</i>	12-1-73		
			SKYLAB CSM	OWC NO
			116 THRU 119	2.6
			34 X 66	PAGE 2-6 SHEET 1 OF 1

FOLDOUT FRAME 4

2024

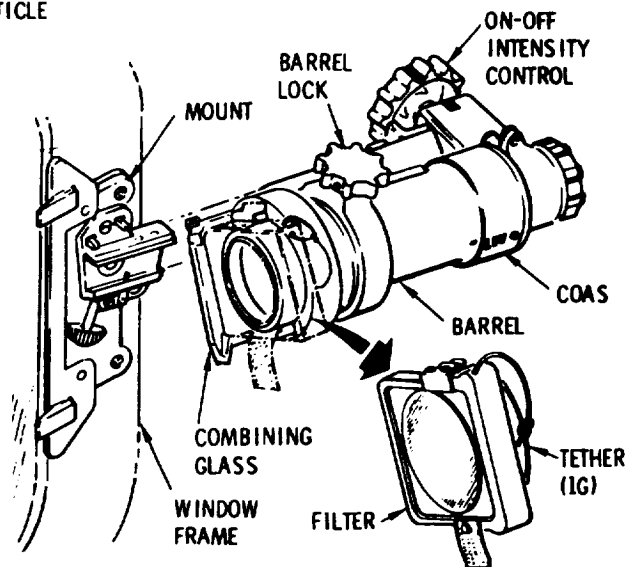
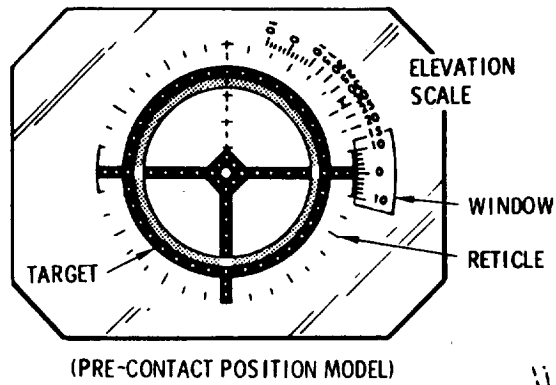
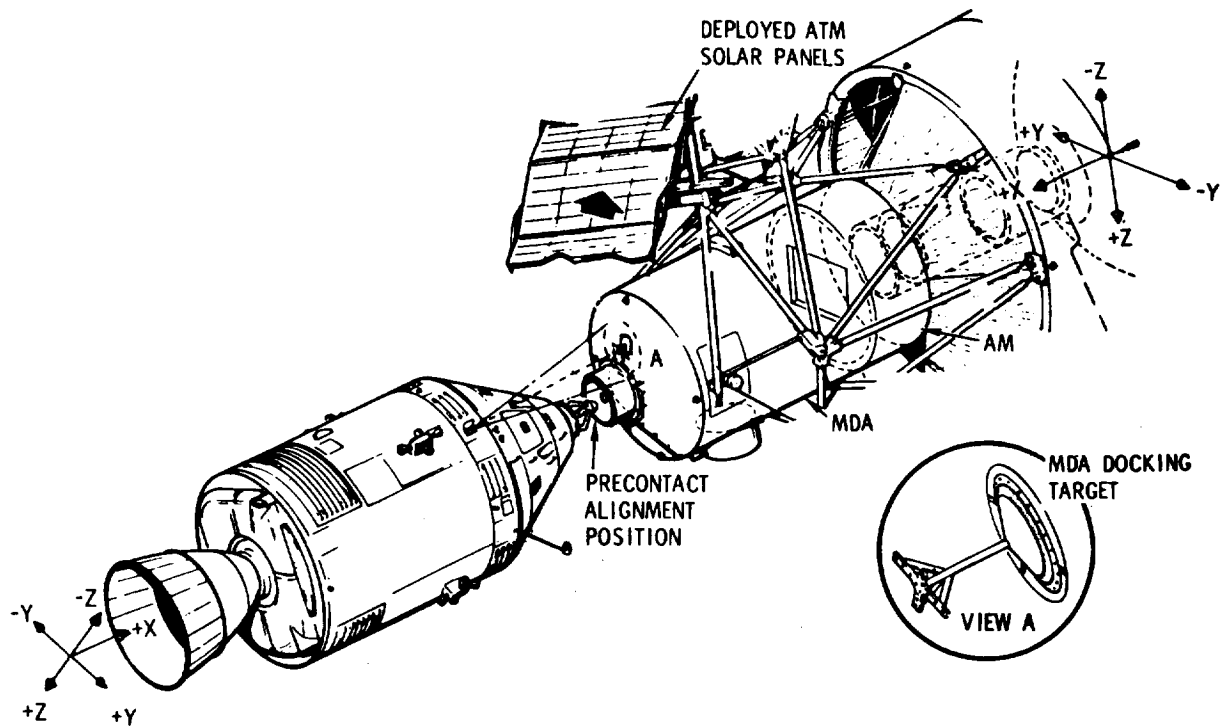

CREWMAN OPTICAL ALIGNMENT SIGHT SYSTEM  
APRON ITEM DWG NO 2.7

**EXPLODE FRAME**



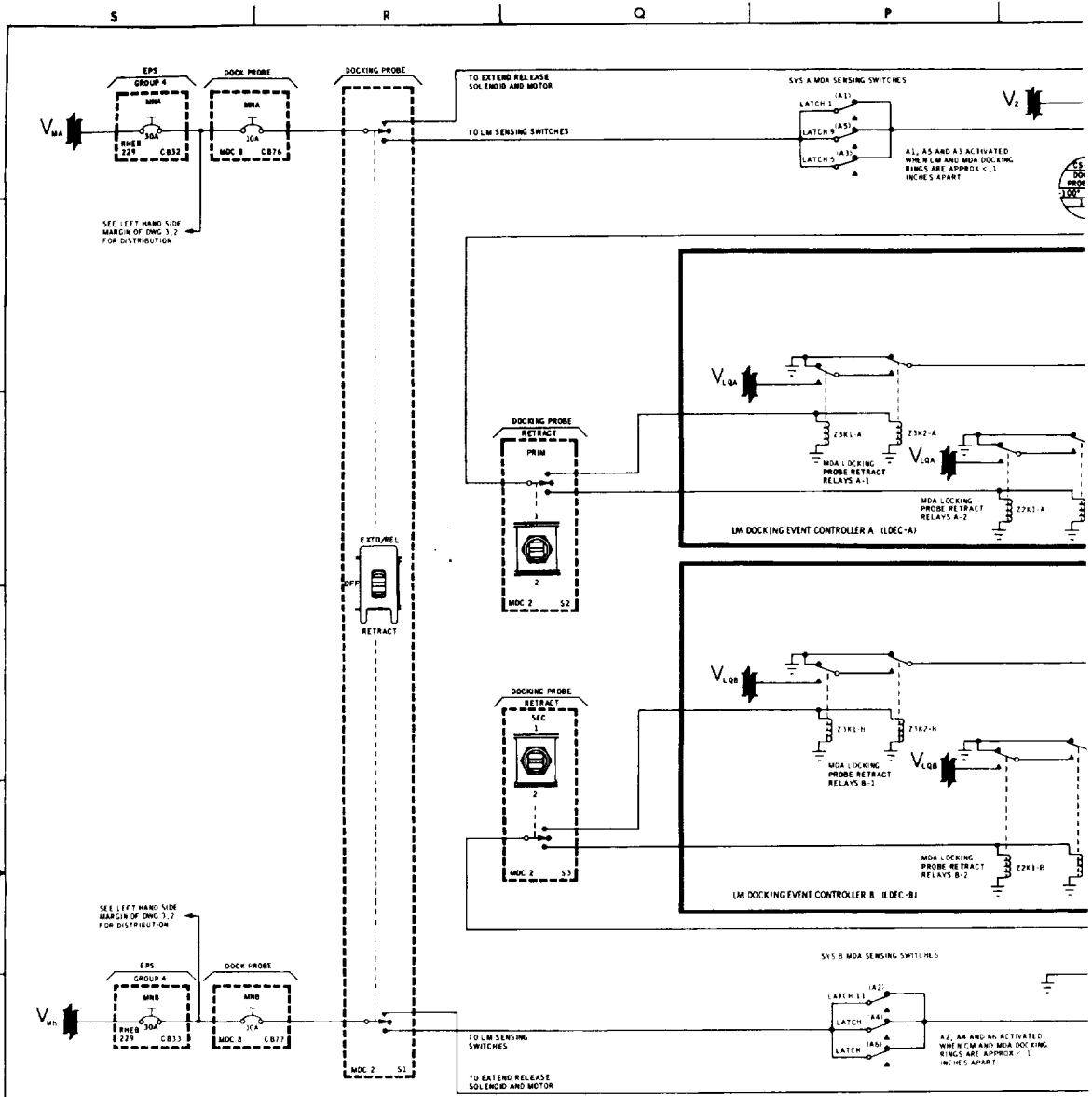

	DOCKING PROBE EXT/REL-RET SWITCH POSITION	NORMAL EXTENSION FROM >10 INCHES	PROBE < 3/4 IN	PROBE > 3/4 IN < 10 IN	NO PROBE POWER	PROBE > 10 IN BUT CAPTURE LATCHES NOT CLOKED
EXTENSION	EXTD					
	OFF					
	RET					
	SHOCK	YES	NO	NO	NO	YES

	DOCKING PROBE EXT/REL-RET SWITCH POSITION	NORMAL PRIOR TO CAPTURE	NORMAL AT CAPTURE
CAPTURE	EXTD		
	OFF		
	RET		
	SHOCK	NO	YES

	DOCKING PROBE EXT/REL-RET SWITCH POSITION	NORMAL RE TRACTION (HARD OFF FLW)
RETRACTION	EXTD	
	OFF	
	RET	
	SHOCK	YES

\* DO NOT PLACE SWITCH IN THIS POSITION

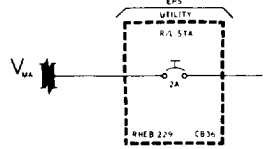

TO UT POWER PNL





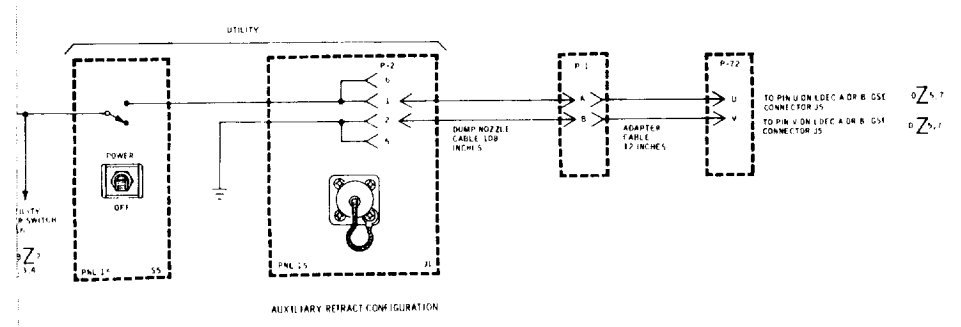
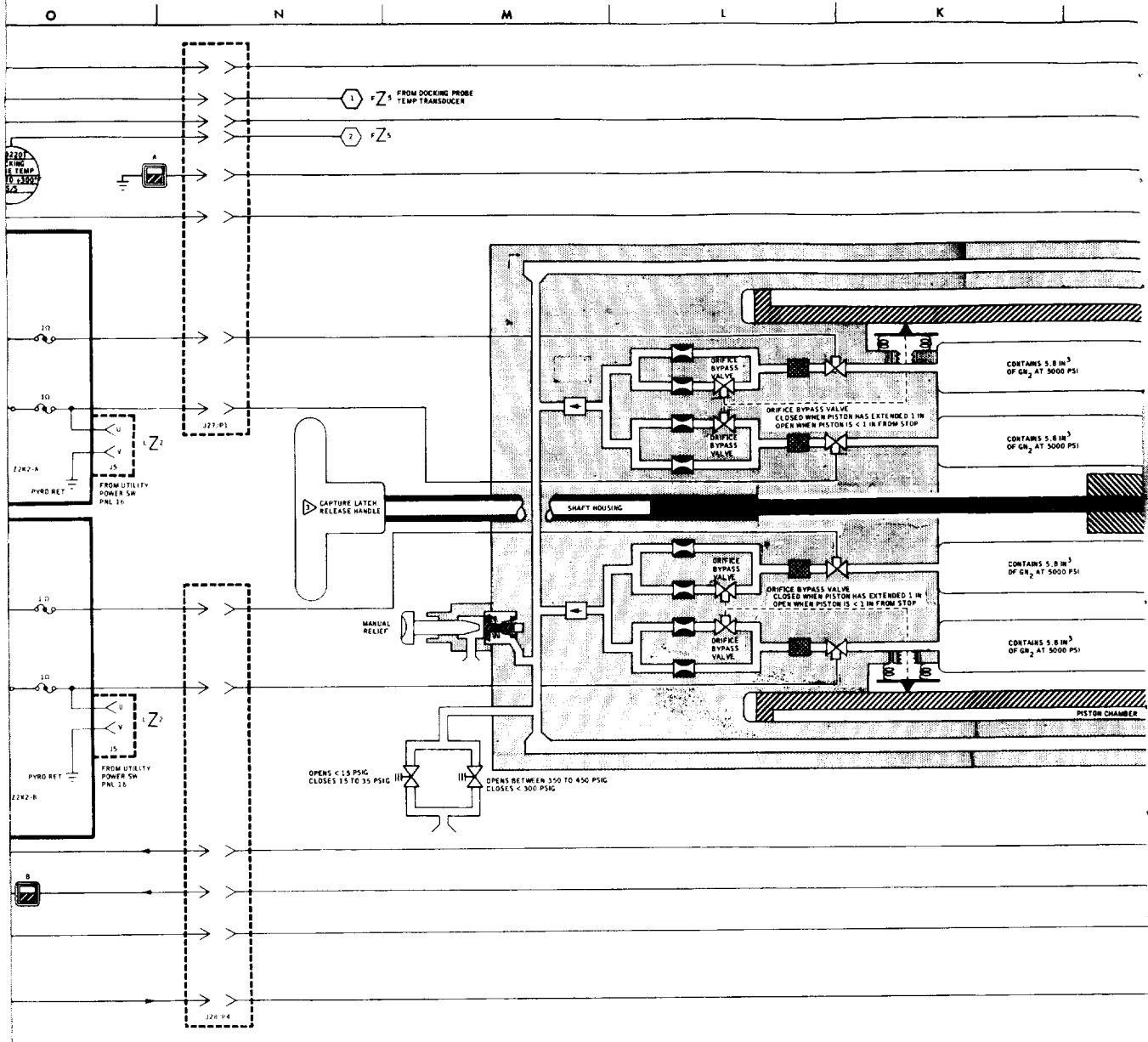



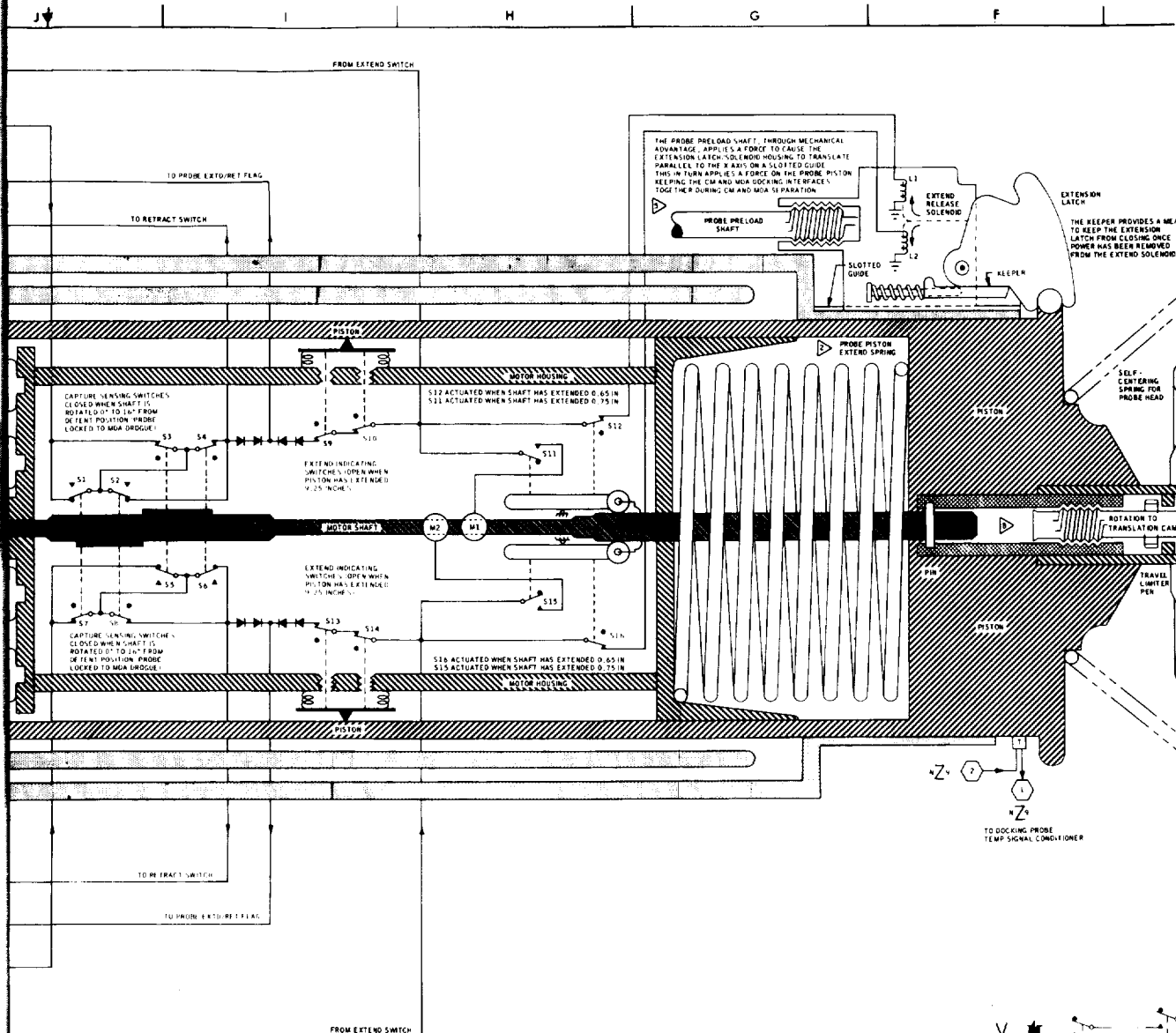

FOLDOUT FRAME 4



CTR	PCN	OR	ENGR	DATE	APPROVAL

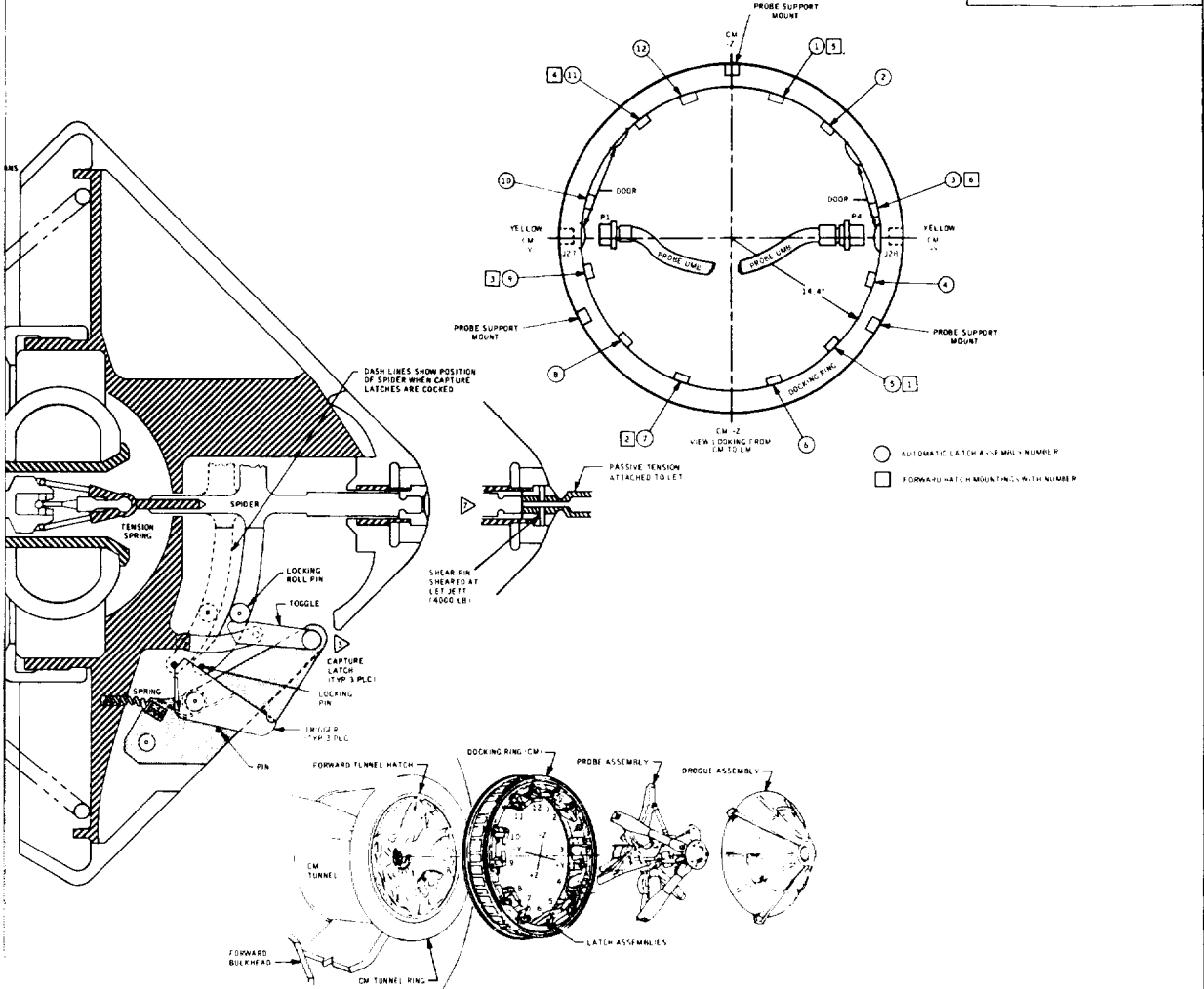

- 1. THE CAPTURE LATCHES ARE LOCKED PRIOR TO OFF-LOAD INSTALLATION OF THE PASSIVE TENSION PIN.
- 2. FOR LOCATION AND ELECTRIC CONTROL OF LIGHT AND TARGET SEE DRAWING W SECTION 11.
- 3. COM/MDA SEPARATION IS ACCOMPLISHED BY THE CREW APPLYING A PRELOAD ON THE EXTENSION SHAFT BY MEANS OF A PERMANENTLY INSTALLED TORQUE PRELOAD HANDLE. WHEN A PRELOAD HAS BEEN APPLIED AT THE INTERFACE, THE CREW WILL MANUALLY RELEASE AND COCK THE 12 AUTOMATIC DOCKING LATCHES. AFTER THE FORWARD FUNNEL HATCH HAS BEEN INSTALLED, THE CREW WILL PLACE THE EXT-DREL-RETRACT SWITCH MODE 2 TO THE EXT-DREL POSITION TO EFFECT COM/MDA UNDOCKING.
- 4. DRIFF BYPASS VALVE
  - DURING THE LAST ONE INCH OF THE RETRACT CYCLE, THE DRIFF BYPASS VALVE WILL BE OPEN ALLOWING THE PRESSURE CHAMBER TO BUILD UP TO 250 PSIG.
- 5. CAPTURE LATCHES MOTOR SHAFT
  - A. THE CAPTURE LATCHES ARE UNLOCKED BY THE MOTOR ROTATING THE MOTOR SHAFT FROM 0° TO 180° CLOCKWISE WHEN THE EXT-DREL-RETRACT SWITCH(S) MODE 2 IS PLACED IN THE EXT-DREL POSITION AND PROBE HAS TRAVELED 3/4 INCH.
    - 1) THE MOTOR SHAFT APPLIES A TORQUING MOMENT TO THE ROTATION TO TRANSLATION CAM. THE ADDITION TO TRANSLATION CAM IN TURN APPLIES A TENSION FORCE TO THE TENSION SPRING, PULLING THE SPIDER DOWN AND ALLOWING THE LOCKING PIN TO ENGAGE THE TRIGGER (COCKS THE CAPTURE LATCHES).
    - 2. THE MOTOR SHAFT IS KEPT IN A COCKED POSITION BY THE LOCKING PIN. PREVENTS THE TENSION SPRING FROM ROTATING THE SHAFT COUNTerclockwise UNTIL THE PROBE HEAD AND MDA PRODUCE MECHANICAL CONTACT CAPTURE.
    - 3) AN INDICATION THAT THIS HAS OCCURRED IS THAT THE PROBE EXT-DREL A AND B FEELS ON MODE 2 WILL CHANGE FROM GRAY TO BARBER.
  - B. WHEN THE PROBE HEAD AND MDA PRODUCE CONTACT, THE THREE CAPTURE LATCHES, THROUGH MECHANICAL ACTION, RELEASE THE LOCKING PIN WHICH IS HOLDING THE SPIDER DOWN, ALLOWING THE TENSION SPRING TO DRIVE THE SHAFT BACK TO 0°.
    - 1) AN INDICATION THAT THIS HAS OCCURRED IS THE PROBE EXT-DREL A AND B FEELS ON MODE 2 CHANGE FROM GRAY TO BARBER POLE.
    - 2) IF THE EXT-DREL-RETRACT SWITCH(S) MODE 2 HAS PREVIOUSLY BEEN PLACED IN THE RETRACT POSITION, AN AUTOMATIC GAS RETRACTION WILL OCCUR IF THE DOCKING PROBE-RETRACT PRIM OR SEC SWITCH(S) MODE 2 IS AND IS HAVE BEEN PLACED TO AN UNUSED BOTTLE POSITION.
  - C. THE SHAFT RETURNS TO 180° FROM DEFENT WHEN THE CREW ROTATES THE CAPTURE LATCH RELEASE HANDLE CLOCKWISE TO REMOVE THE PROBE UNDOCKS THE CAPTURE LATCHES.
- 6. THE PROBE PISTON SPRING ACTS AS A PRELOAD TO EXTEND THE PROBE ONCE THE PROBE EXTEND LATCH RELEASE SOLENOID HAS BEEN ENERGIZED. THE PROBE EXTENSION LATCH IS ENERGIZED BY PLACING THE EXT-DREL-RETRACT SWITCH (MODE 2) TO THE EXT-DREL POSITION. IN THE RETRACTED POSITION, THE PROBE PISTON EXERTS A FORCE OF 130 LBS ON THE PROBE ASSEMBLY AND 700 LBS WHEN EXTENDED TENCHES.

NOTES: 1. SYSTEM A AND B OF THE DOCKING PROBE AND RELATED ELECTRONIC COMPONENT'S SHOWN.

- 9. MDA RADIAL LOCKING PORT IDENTICAL TO AXIAL EXCEPT IT DOES NOT HAVE POWER TRANSFER CAPABILITY.
- 10. TRANSLATION TO ROTATION CAM DESCRIPTION
  - A. THE MOTOR SHAFT TURNS THE CAM 180° FROM 0° TO UNLOCK THE CAPTURE LATCHES, PULLING THE TENSION SPRING UP.
  - B. WHEN FORCE IS RELEASED FROM THE MOTOR, A TORSION SPRING PULLS THE CAM BACK TO 180° FROM 0° (COCKING THE CAPTURE LATCHES).
  - C. WHEN THE THREE TRIGGERS ARE DEPRESSSED AT DROGUE CAPTURE, THE TORSION SPRING DRIVES THE CAM BACK TO 0°.

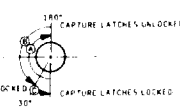

# 7 DOCKING

SIGNATURES		DATE	NATIONAL AERONAUTICS & SPACE ADMINISTRATION	
DR	ENGR		MANNED SPACECRAFT CENTER - HOUSTON, TEXAS	
DR [Signature]	ENGR [Signature]	02/27/70		
DESIGN	ENGR			
APP [Signature]	ENGR	02/27/70		
STC [Signature]	ENGR	02/27/70		
			SKYLAB 5M	27
			110 THRU 119	
			004 N X 30 25	PAGE 2-7 SHEET 1 OF 1



3 ELECTRICAL  
SYSTEM

1

2

3

4

5

6



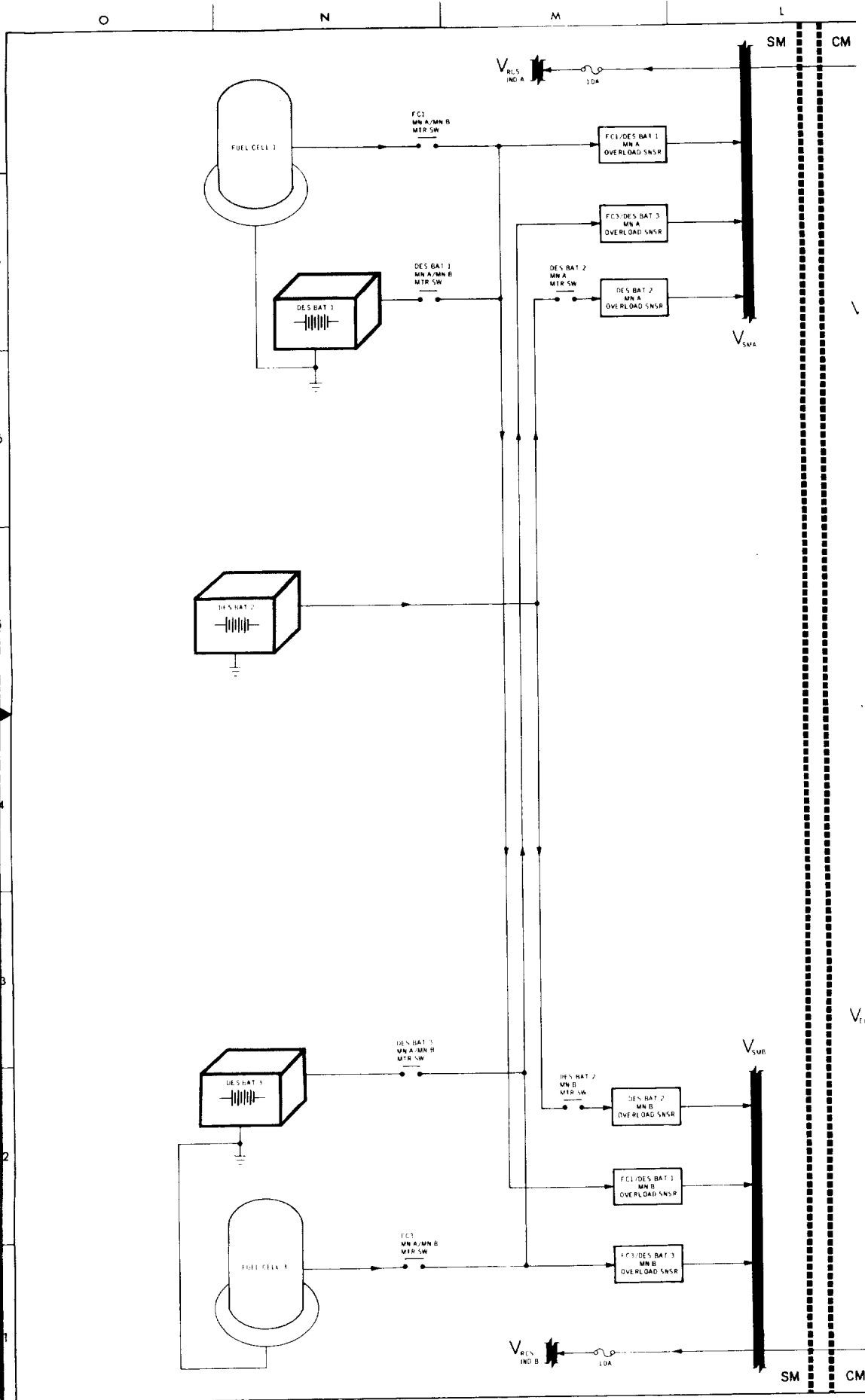

**FOLDOUT FRAME**







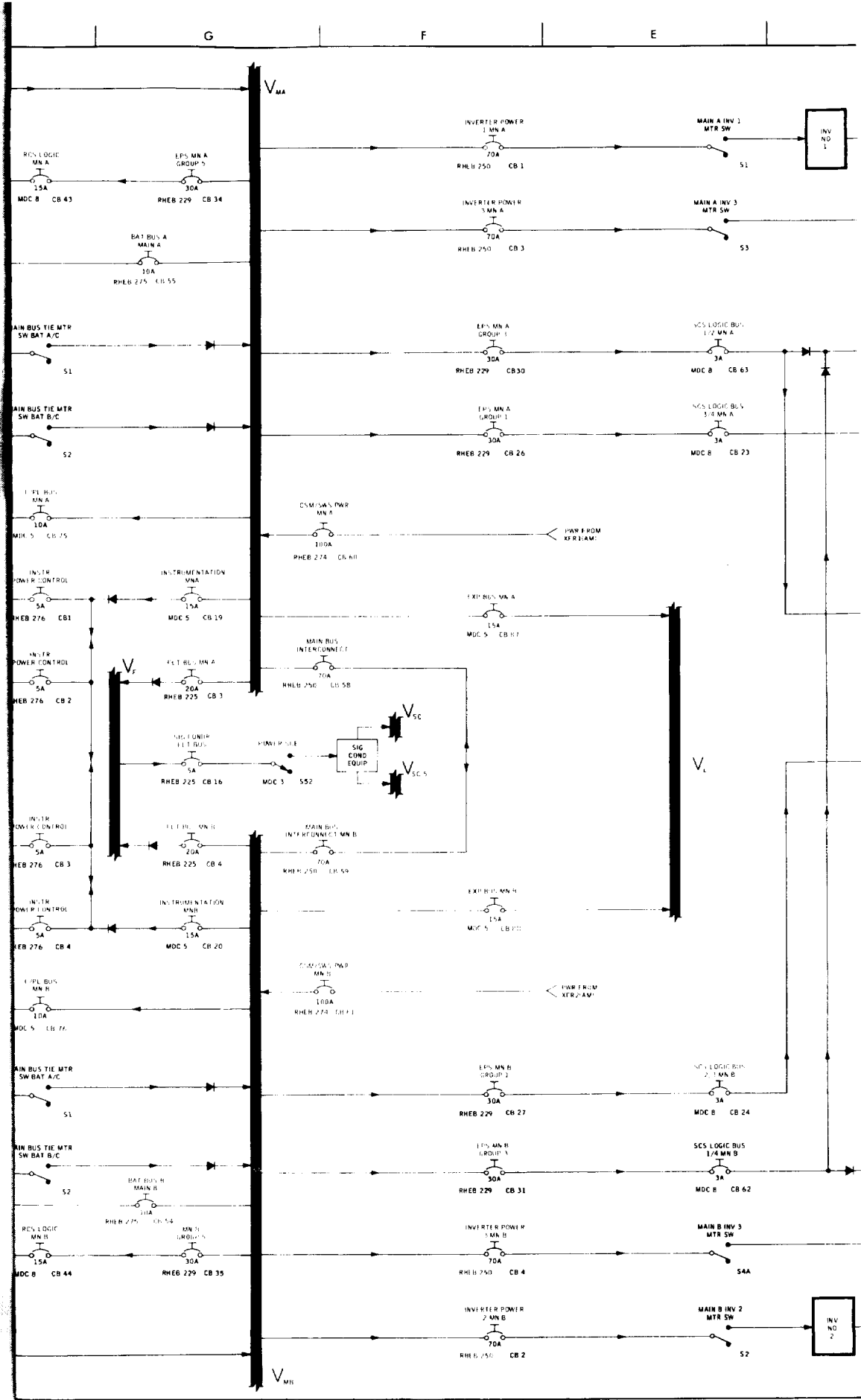

**FOLDOUT FRAME 3**



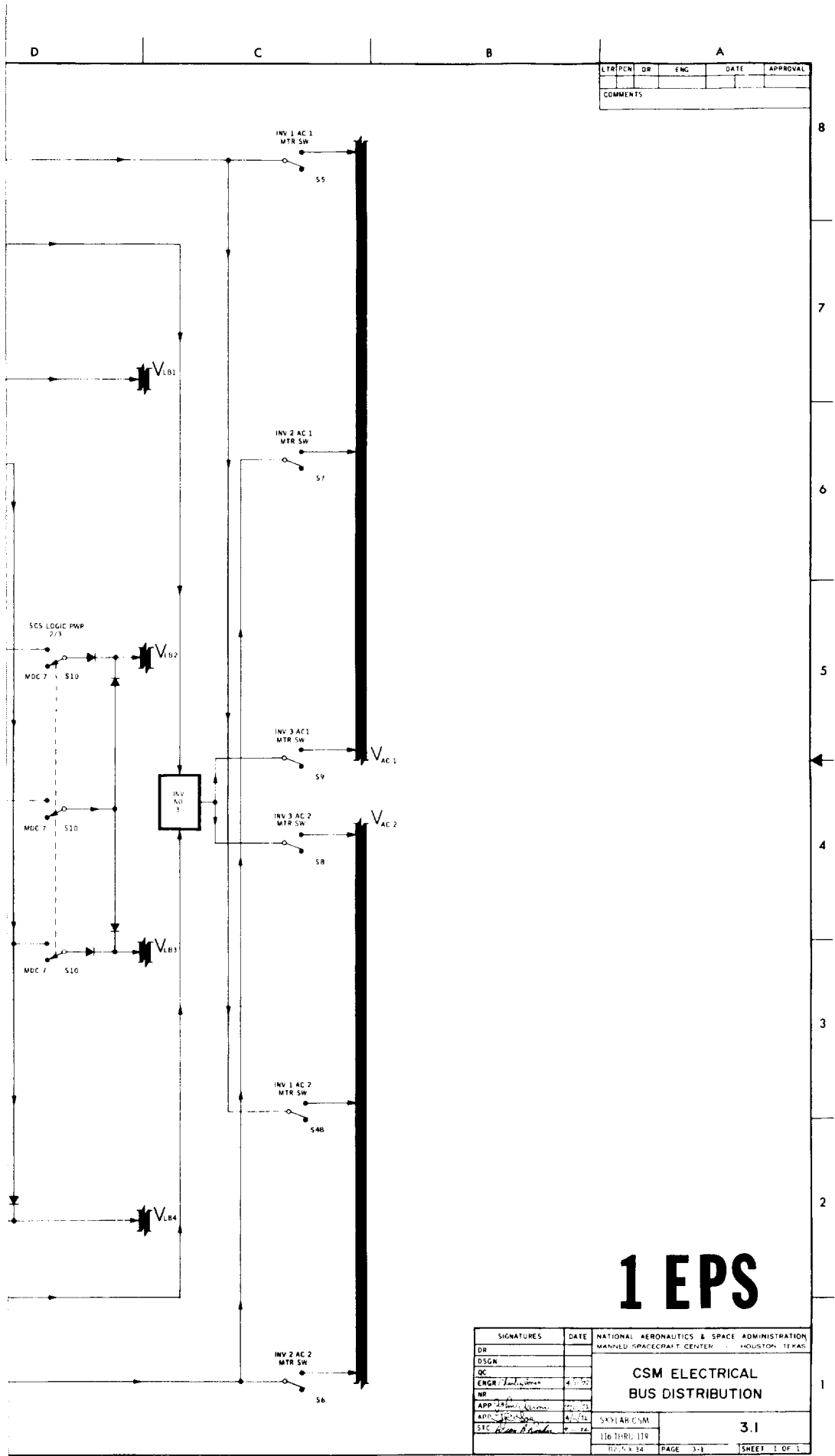

LT/PCW	DR	ENG	DATE	APPROVAL
COMMENTS				

# 1 EPS

SIGNATURES		DATE	NATIONAL AERONAUTICS & SPACE ADMINISTRATION MANNED SPACECRAFT CENTER HOUSTON, TEXAS	
DR			<b>CSM ELECTRICAL BUS DISTRIBUTION</b>	
DSGN				
QC				
ENGR		4/1/72		
NR				
APP		7/2/73	SAXLAR CSM	3.1
APPC		6/2/76	110-3181-119	
STC		6/2/76		
		PAGE 3-1	SHEET 3 OF 3	

FOLDOUT FRAME 4





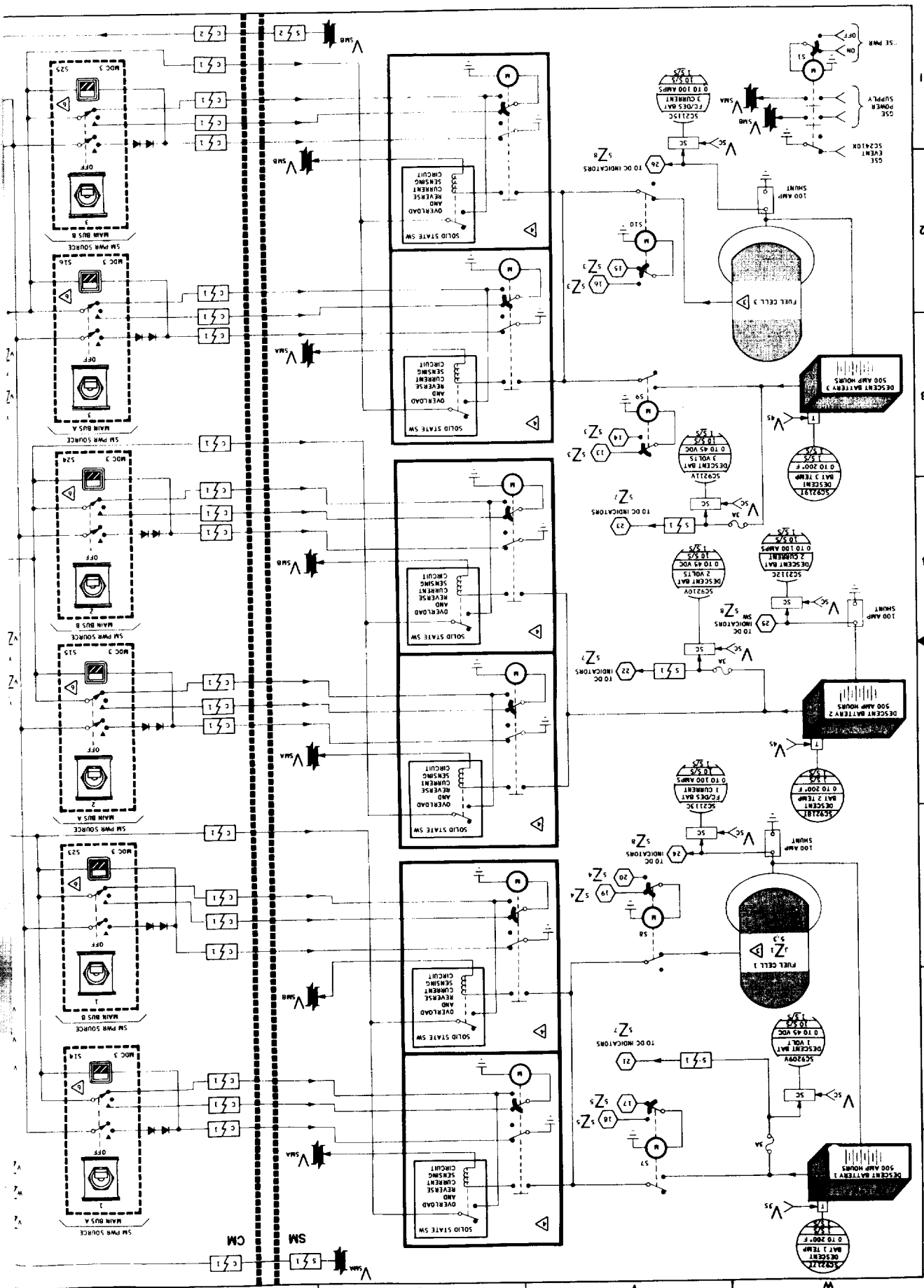

FOLDOUT FRAME



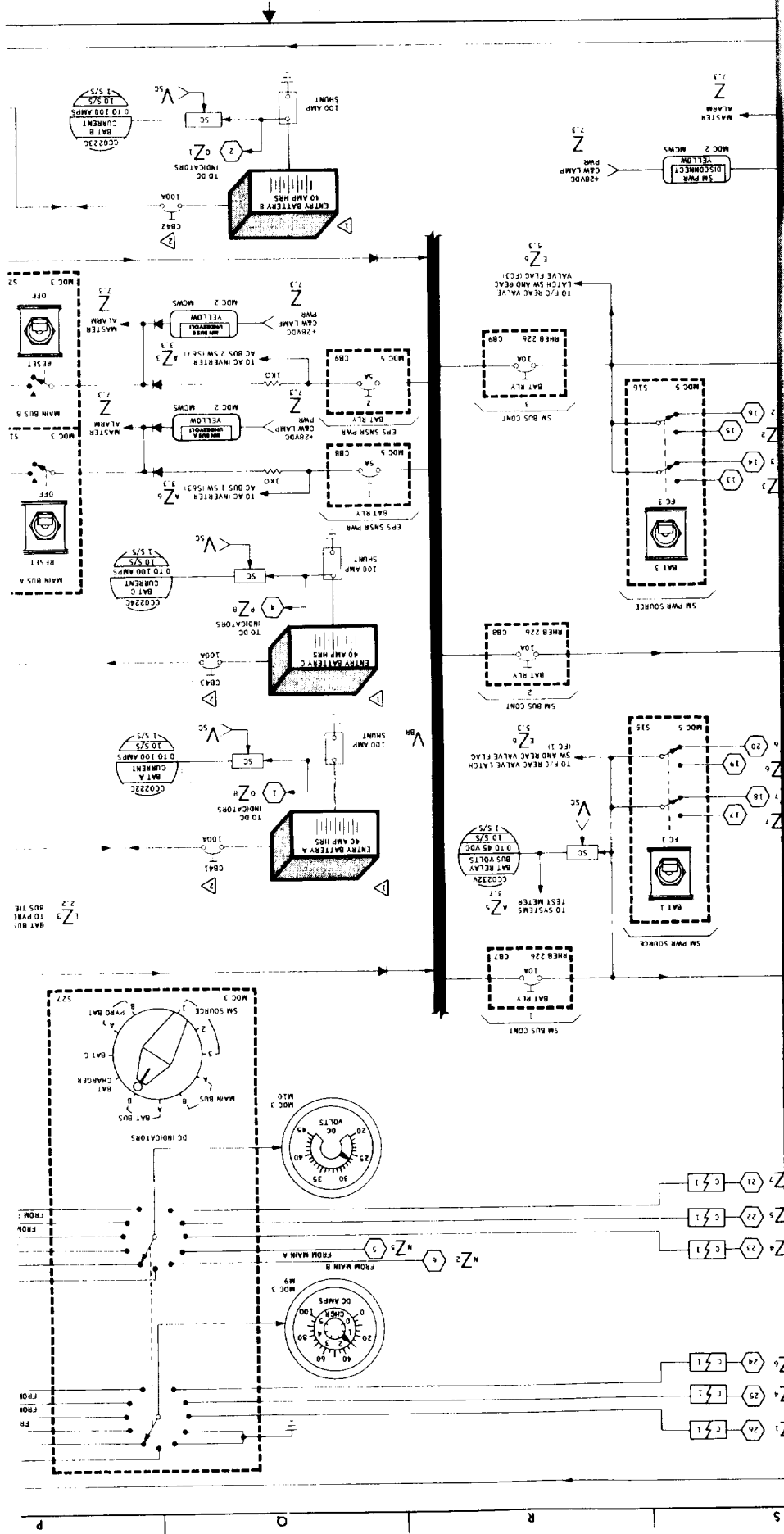

FOLDOUT FRAME 2



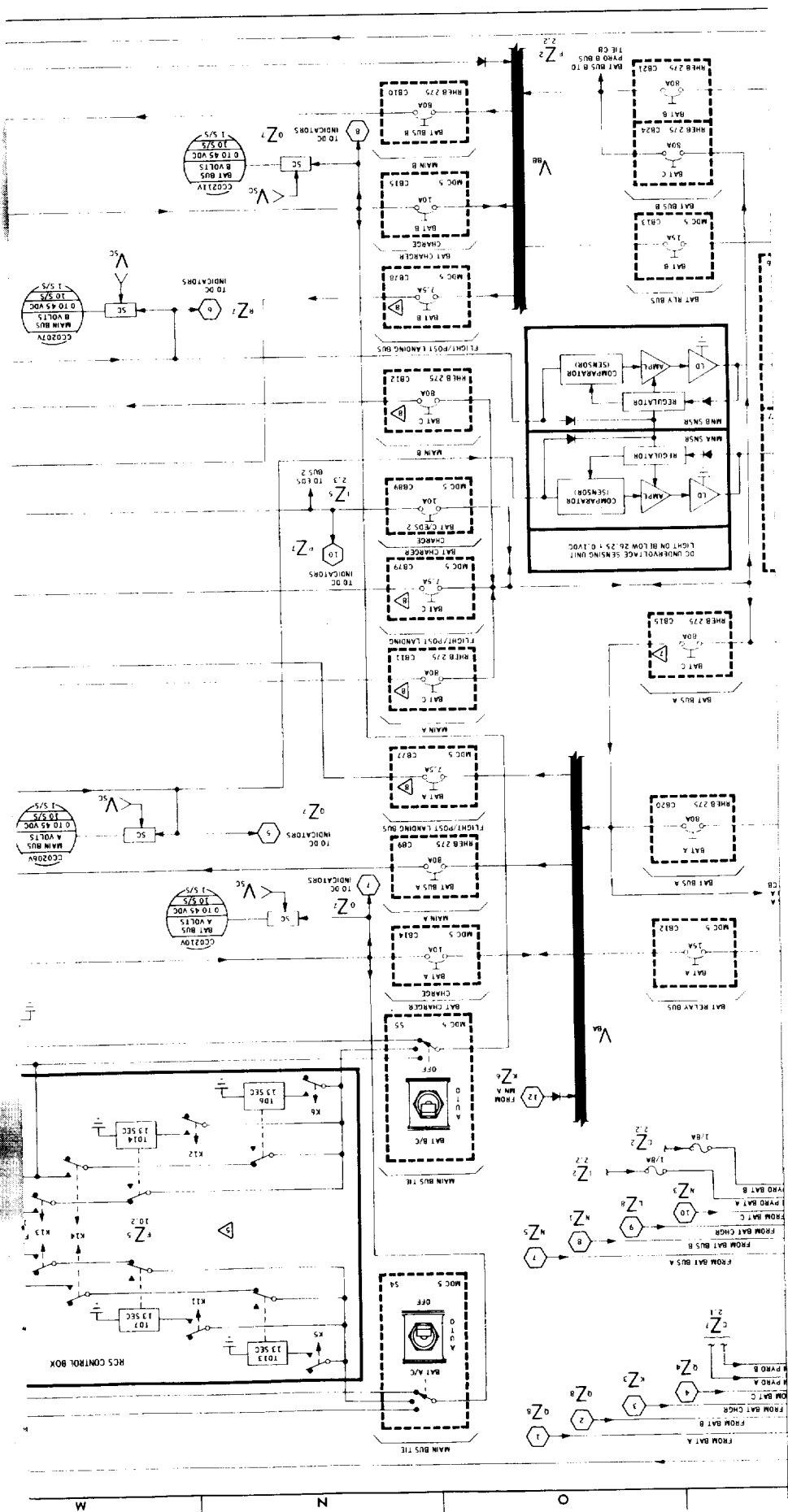

FOLDOUT FRAME 3



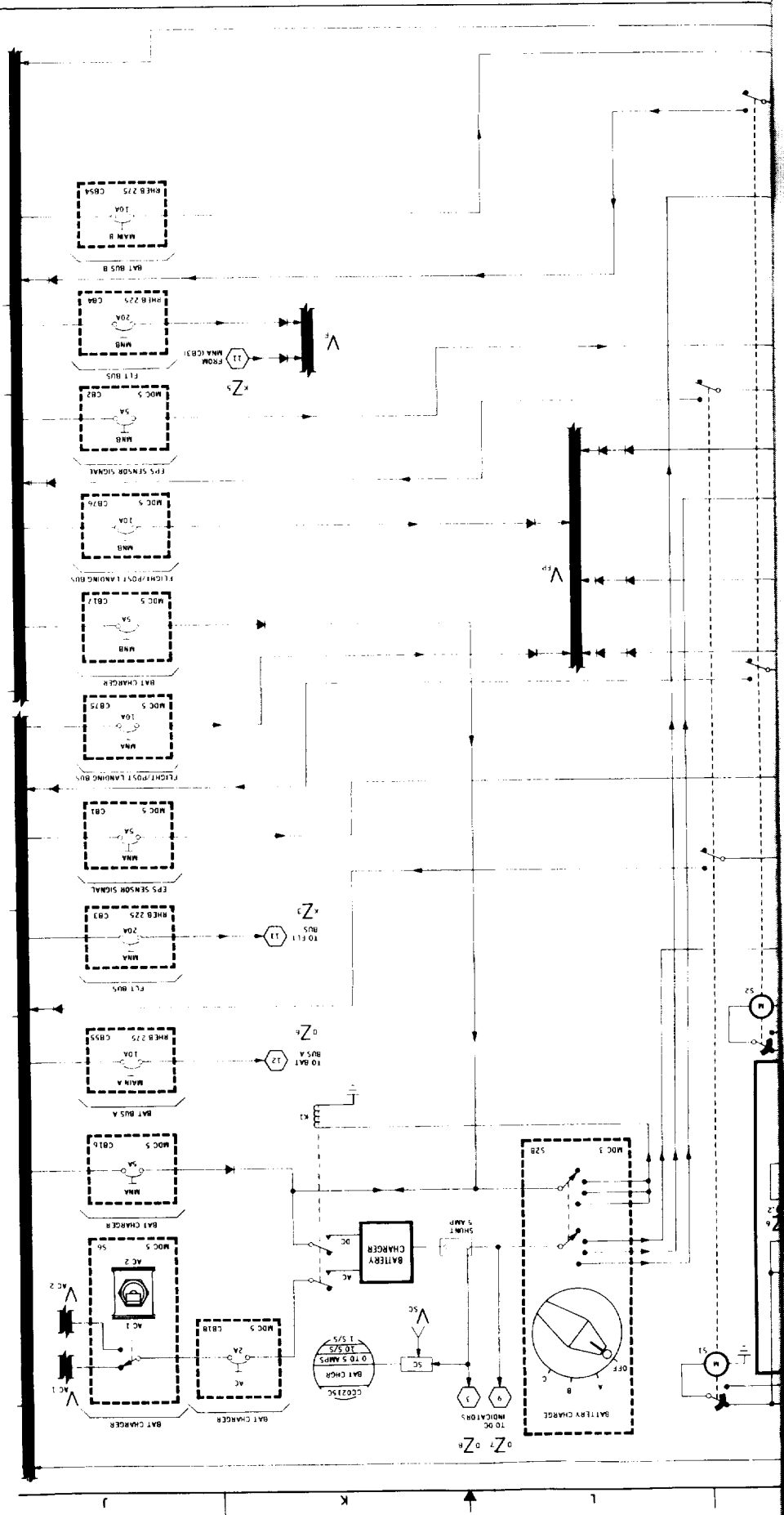

FOLDOUT FRAME 4





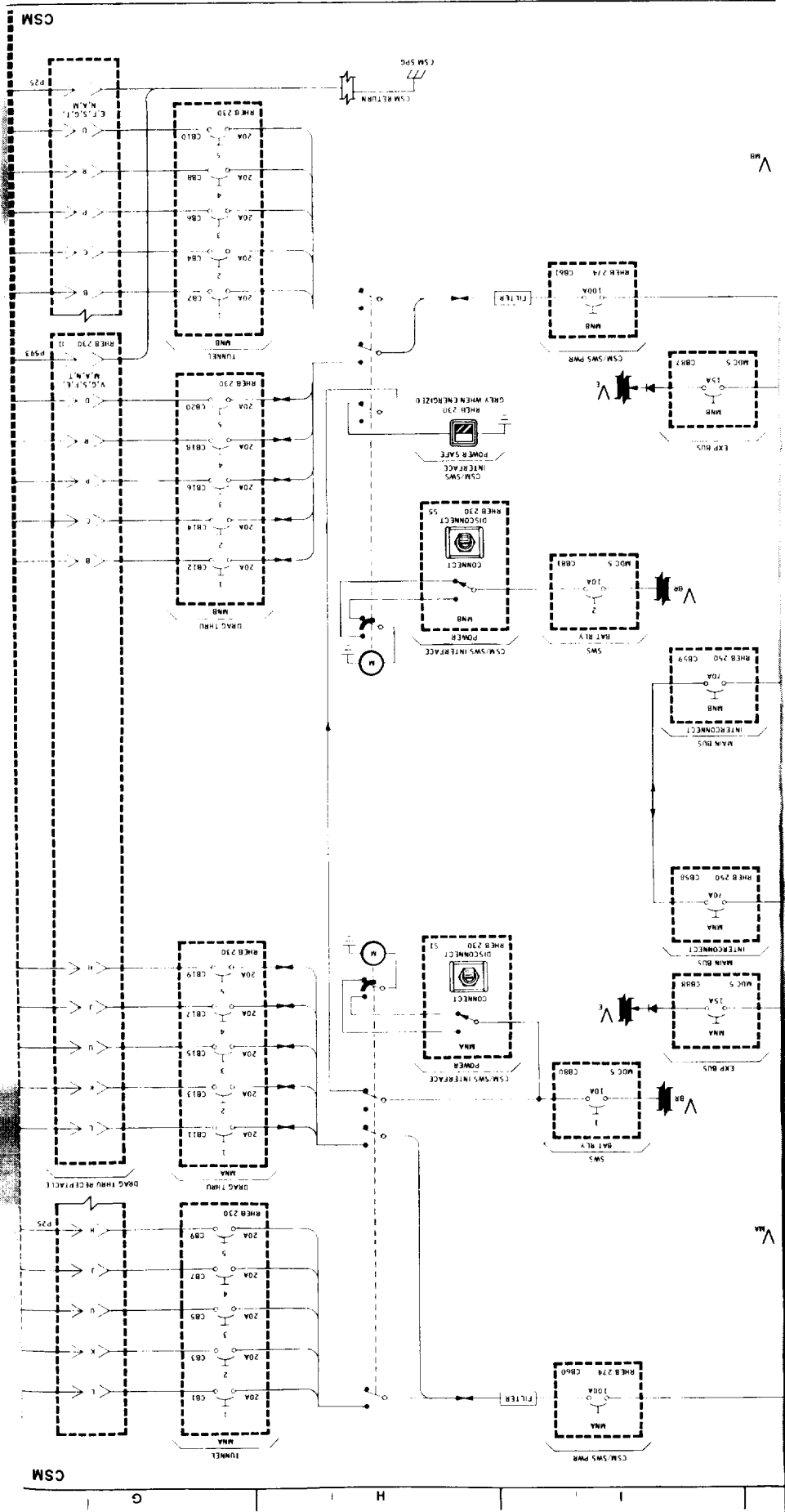

FOLDOUT FRAME 5



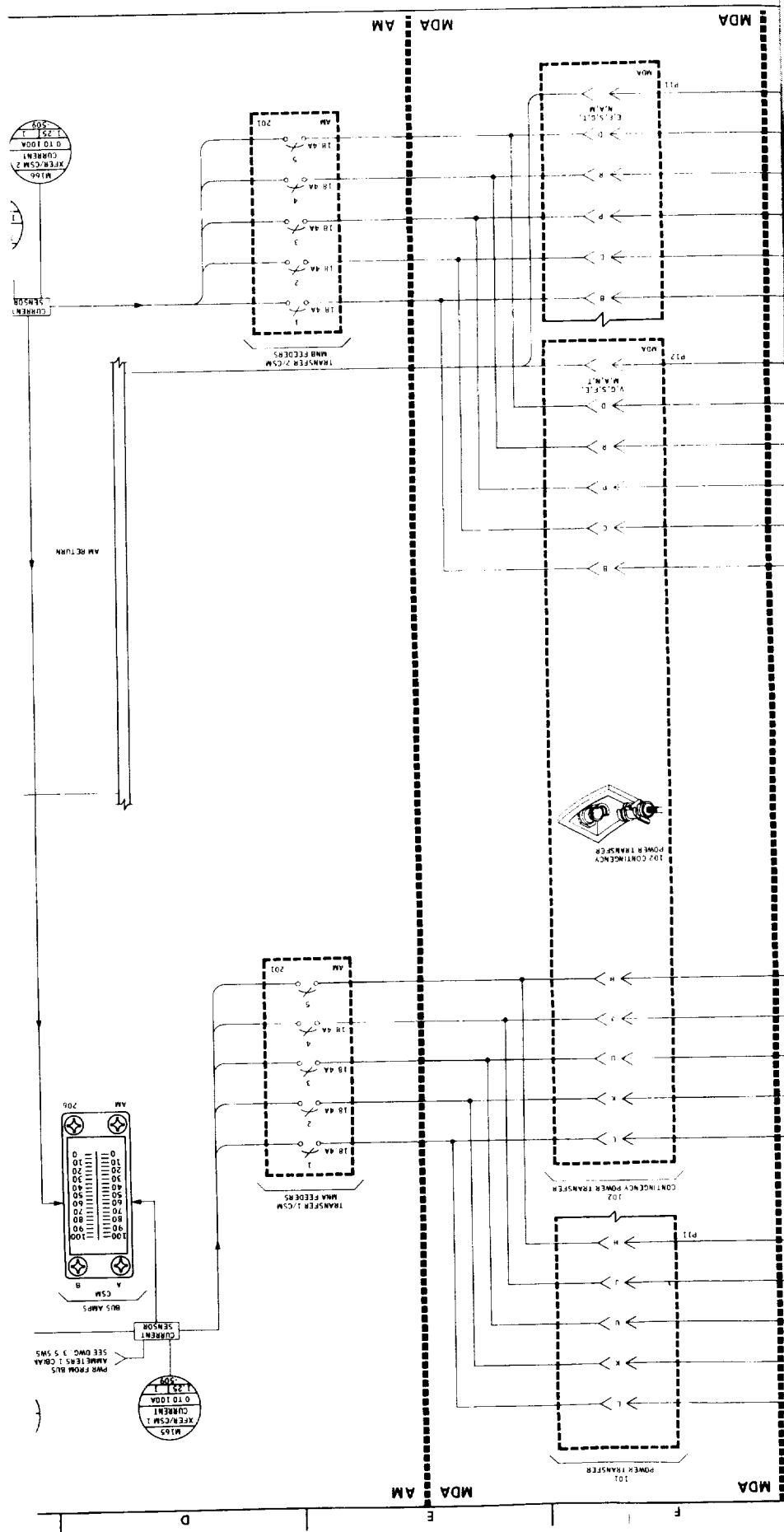

**FOLDOUT FRAME 6**



DATE	2-7-72	DR	M. J. ...
SIGNATURES			
NATIONAL AERONAUTICS & SPACE ADMINISTRATION MANNED SPACECRAFT CENTER - HOUSTON, TEXAS			
PROJECT	126,5 X 3A	WAC	3-2
SHEET	1 OF 3		
<b>3.2</b>			
<b>SYSTEM</b>			
<b>ELECTRICAL DIRECT CURRENT DISTRIBUTION AND CONTROL</b>			
FIG. NO.	119	APP.	...
REV.	...	DATE	...
BY	...	DATE	...
CHKD.	...	DATE	...
APP.	...	DATE	...
DATE	...	BY	...

# 2DC

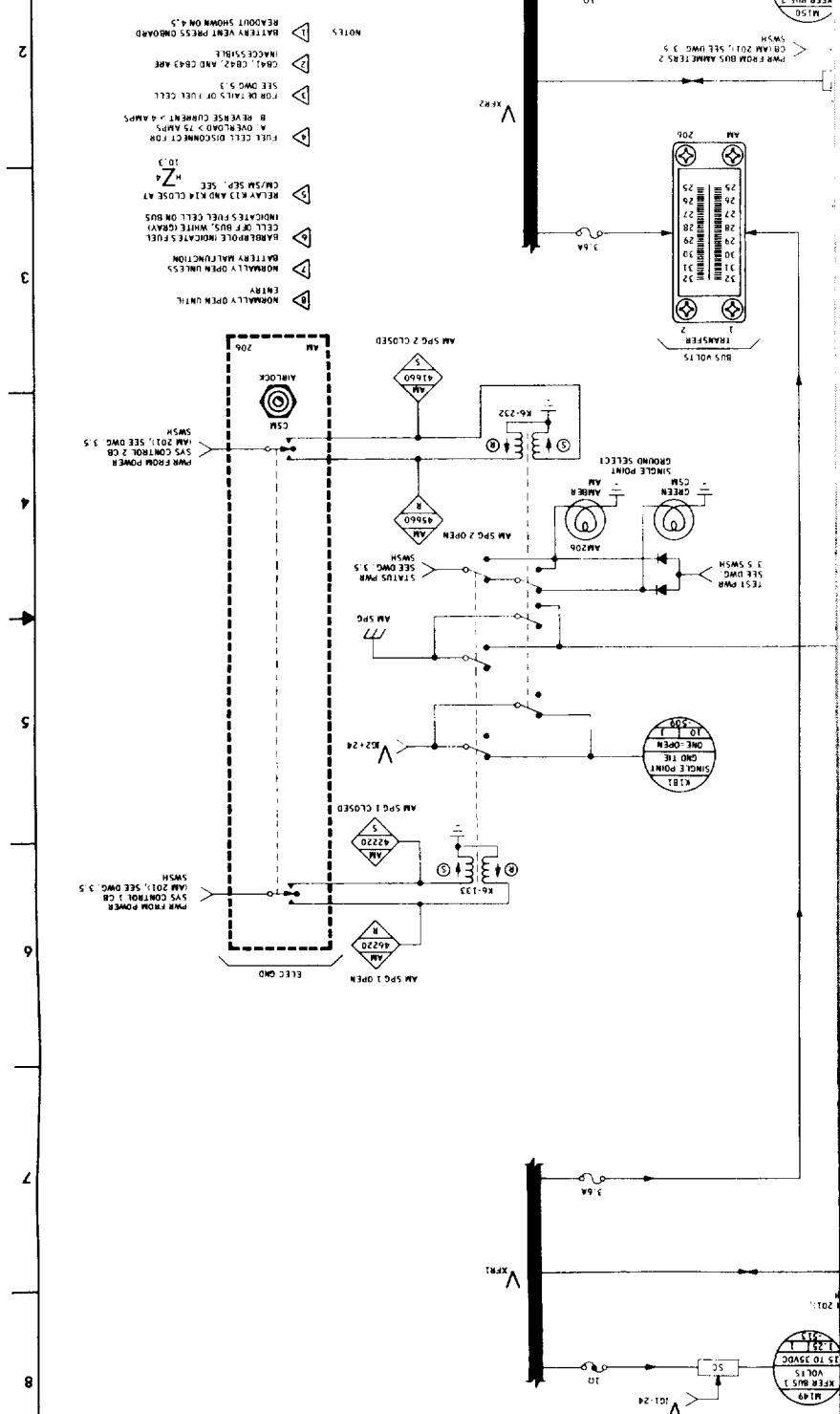

- NOTES
- ▷ BATTERY VENT PRESS ONBOARD
  - ▷ INACCESSIBLE
  - ▷ CABLE, CORDS, AND CRDS ARE
  - ▷ SEE DWG 3.3
  - ▷ FROM TAILS OF FUEL CELL
  - ▷ FUEL CELL DISCONNECT 2.4 AMPS
  - ▷ R. OVERLOAD > 75 AMPS
  - ▷ B. REVERSE CURRENT > 4 AMPS
  - ▷ CM/SM DEP. SEE
  - ▷ RELAYS K13 AND K14 CLOSE AT
  - ▷ INDICATES FUEL CELL ON BUS
  - ▷ CELL OFF BUS, WHITE (GRAY)
  - ▷ BATTERY VENT PRESS ONBOARD
  - ▷ NORMALLY OPEN UNLESS
  - ▷ BATTERY MALFUNCTION
  - ▷ NORMALLY OPEN UNLESS
  - ▷ EMPTY
  - ▷ NORMALLY OPEN UNLESS

COMMENTS				
DATE	DR	ENGR	DATE	APPROVAL

FOLDOUT FRAME 7



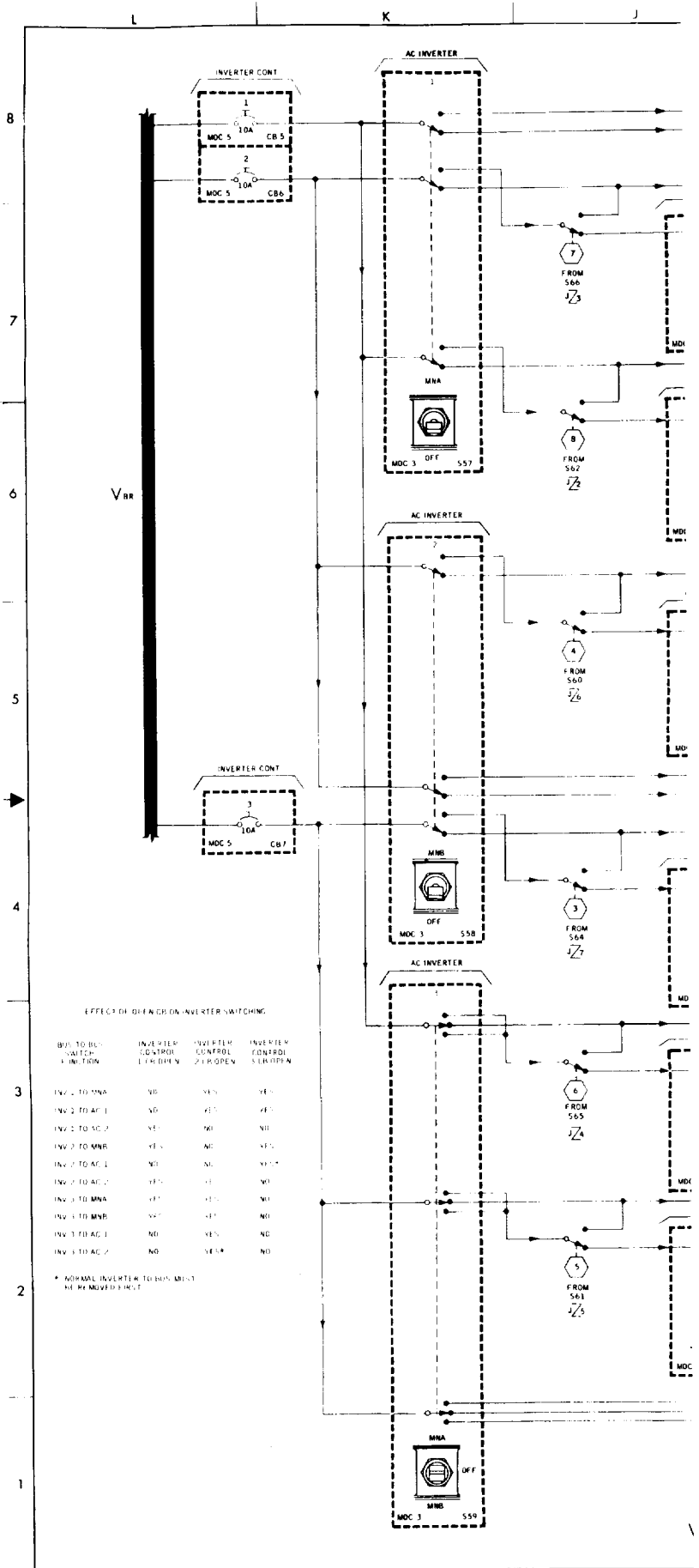

EFFECT OF OFF POSITION ON INVERTER SWITCHING

BUS TO BUS SWITCH POSITION	INVERTER CONTROL 1 (OFF)	INVERTER CONTROL 2 (OFF)	INVERTER CONTROL 3 (OFF)
INV 1 TO MNA	NO	YES	YES
INV 2 TO AC 1	NO	YES	YES
INV 2 TO AC 2	YES	NO	NO
INV 2 TO MNB	YES	NO	YES
INV 2 TO AC 1	NO	NO	YES
INV 2 TO AC 2	YES	YES	NO
INV 3 TO MNA	YES	YES	YES
INV 3 TO MNB	YES	YES	NO
INV 3 TO AC 1	NO	YES	NO
INV 3 TO AC 2	NO	YES	NO

\* NORMAL INVERTER TO BUS MUST BE RE-MANUALLY RESET

FOLDOUT FRAME





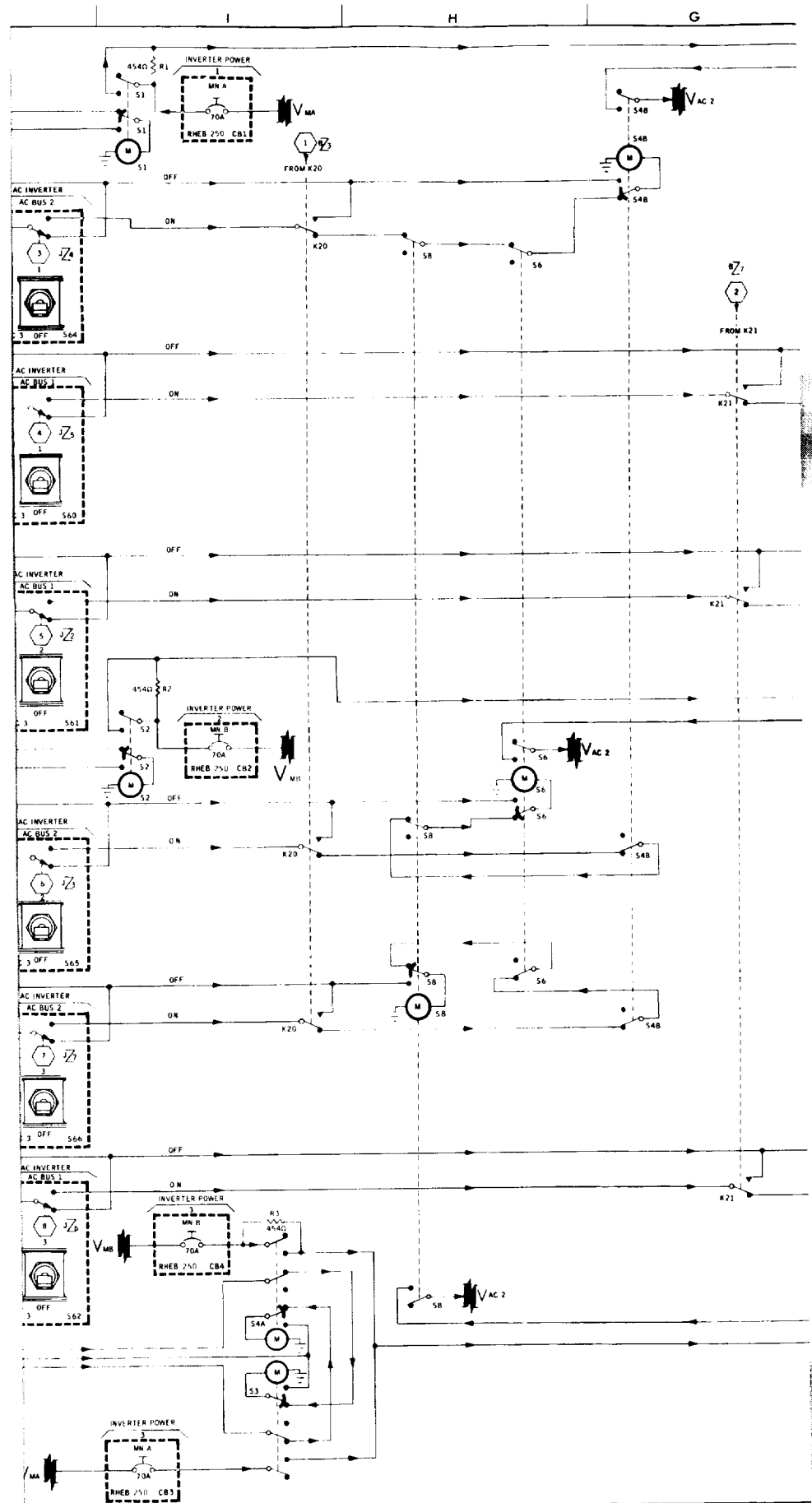

FOLDOUT FRAME 2



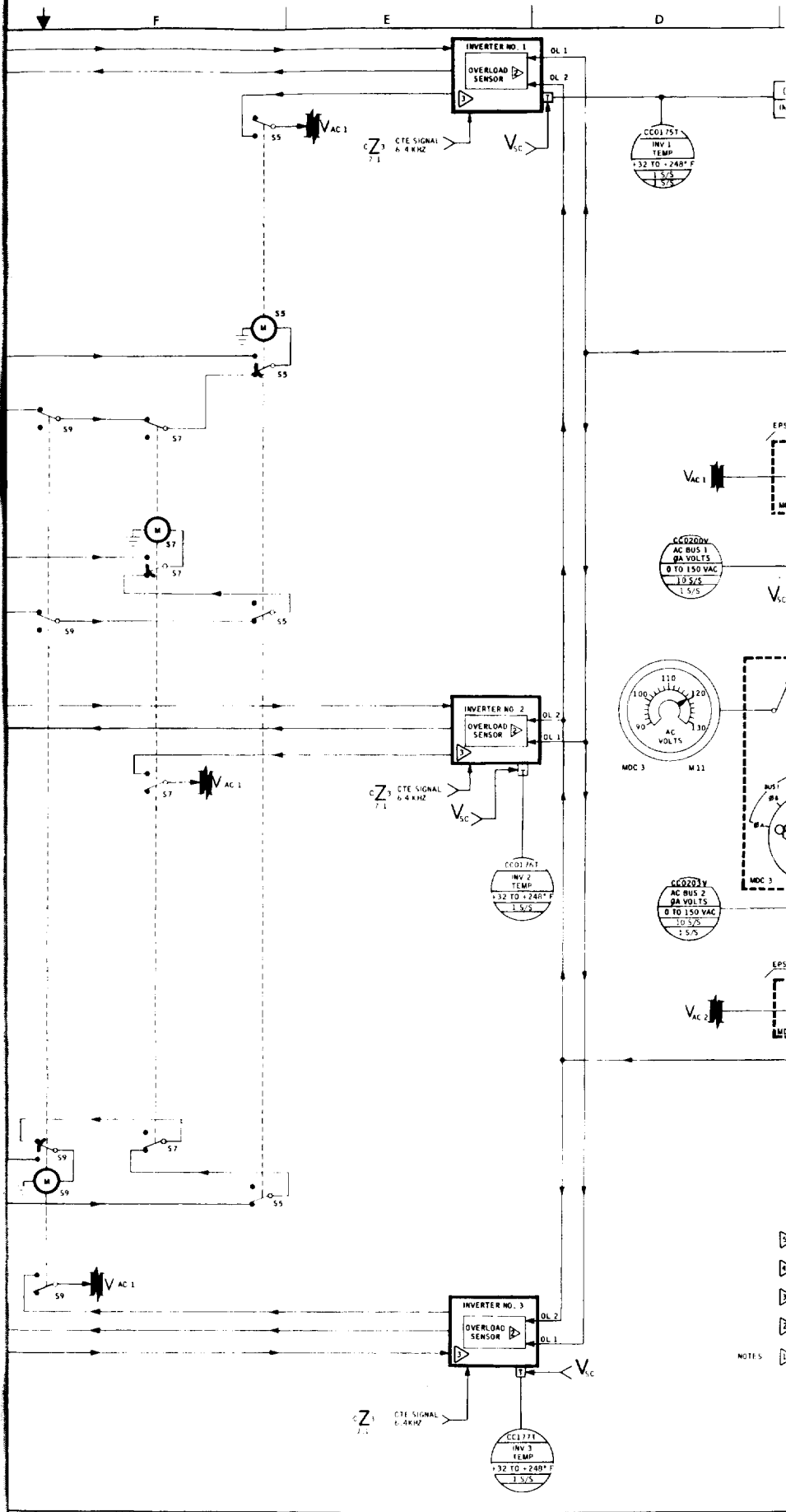

FOLDOUT FRAME 3



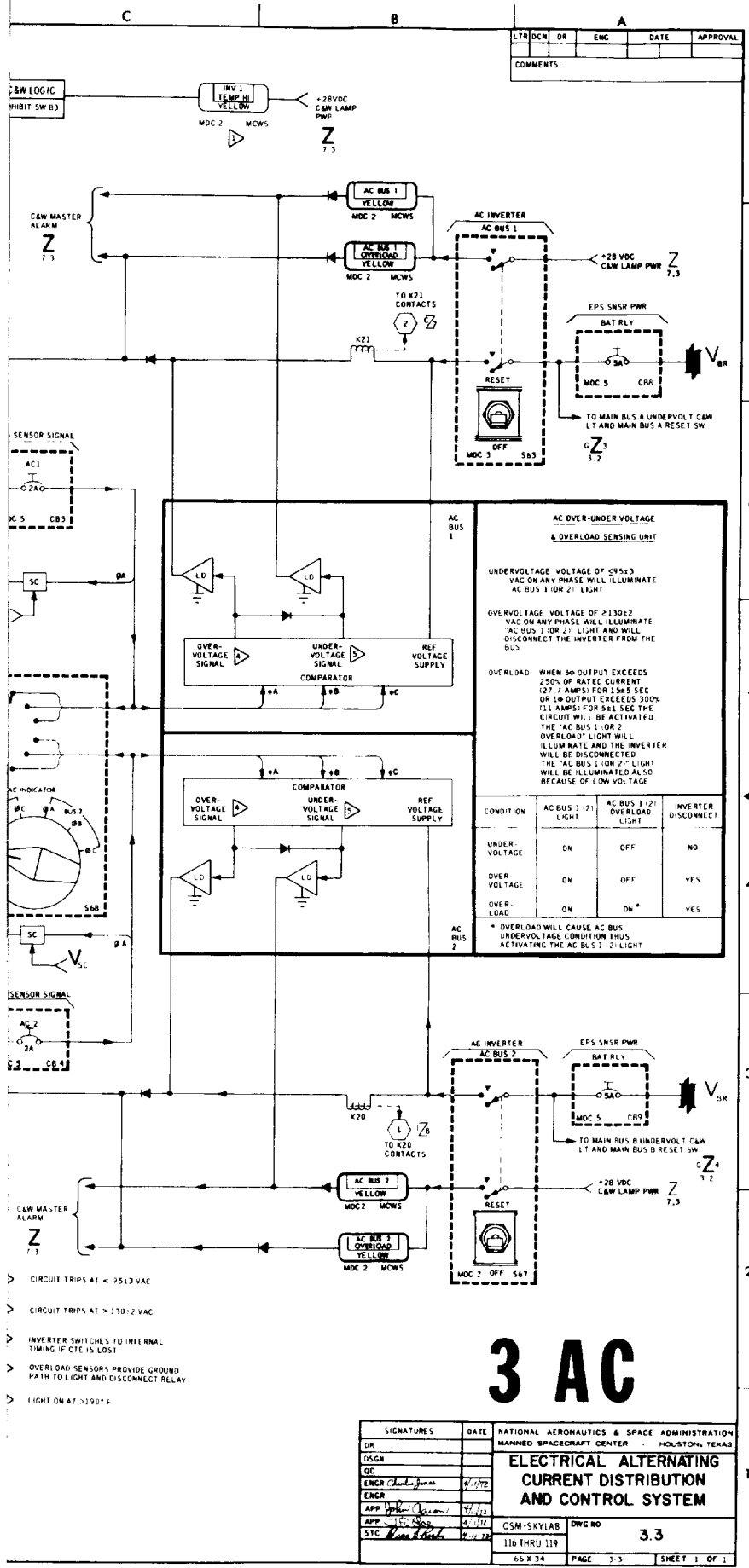

LTR	DCN	OR	ENG	DATE	APPROVAL

COMMENTS:

# 3 AC

- > CIRCUIT TRIPS AT < 95±3 VAC
- > CIRCUIT TRIPS AT > 130±2 VAC
- > INVERTER SWITCHES TO INTERNAL TIMING IF CTE IS LOST
- > OVERLOAD SENSORS PROVIDE GROUND PATH TO LIGHT AND DISCONNECT RELAY
- > LIGHT ON AT >190°±

SIGNATURES		DATE	NATIONAL AERONAUTICS & SPACE ADMINISTRATION MANNED SPACECRAFT CENTER HOUSTON, TEXAS	
DR				
OSGN				
QC				
ENGR	<i>Charles Jones</i>	9/11/72		
ENGR				
APP	<i>John ...</i>	7/1/72		
APP	<i>FS ...</i>	5/1/72		
SYC	<i>...</i>	4/1/72		
CSM-SKYLAB DWG NO			3.3	
116 THRU 119			66 X 34 PAGE 3-3 SHEET 1 OF 1	

FOLDOUT FRAME 4



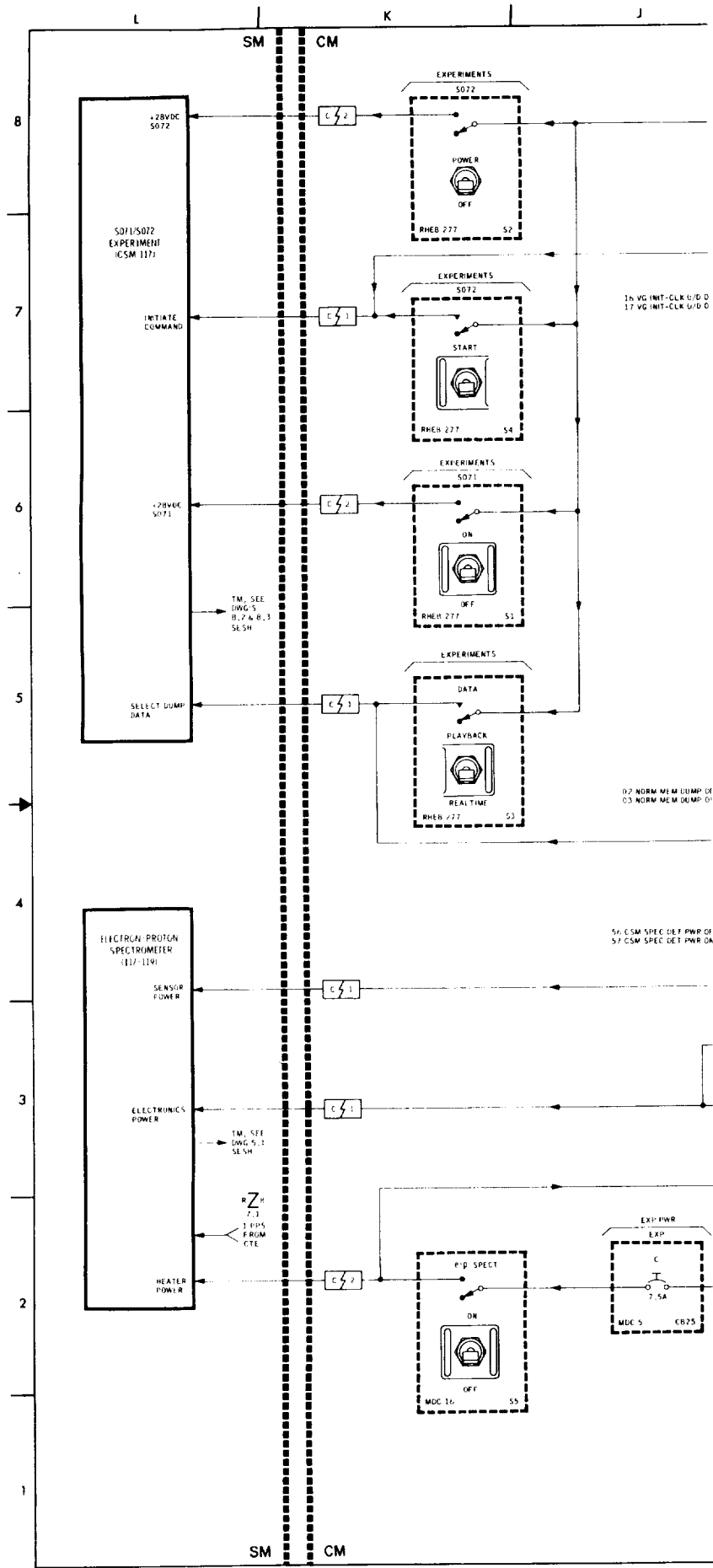

**FOLDOUT FRAME /**





CSM 117, 118 & 119

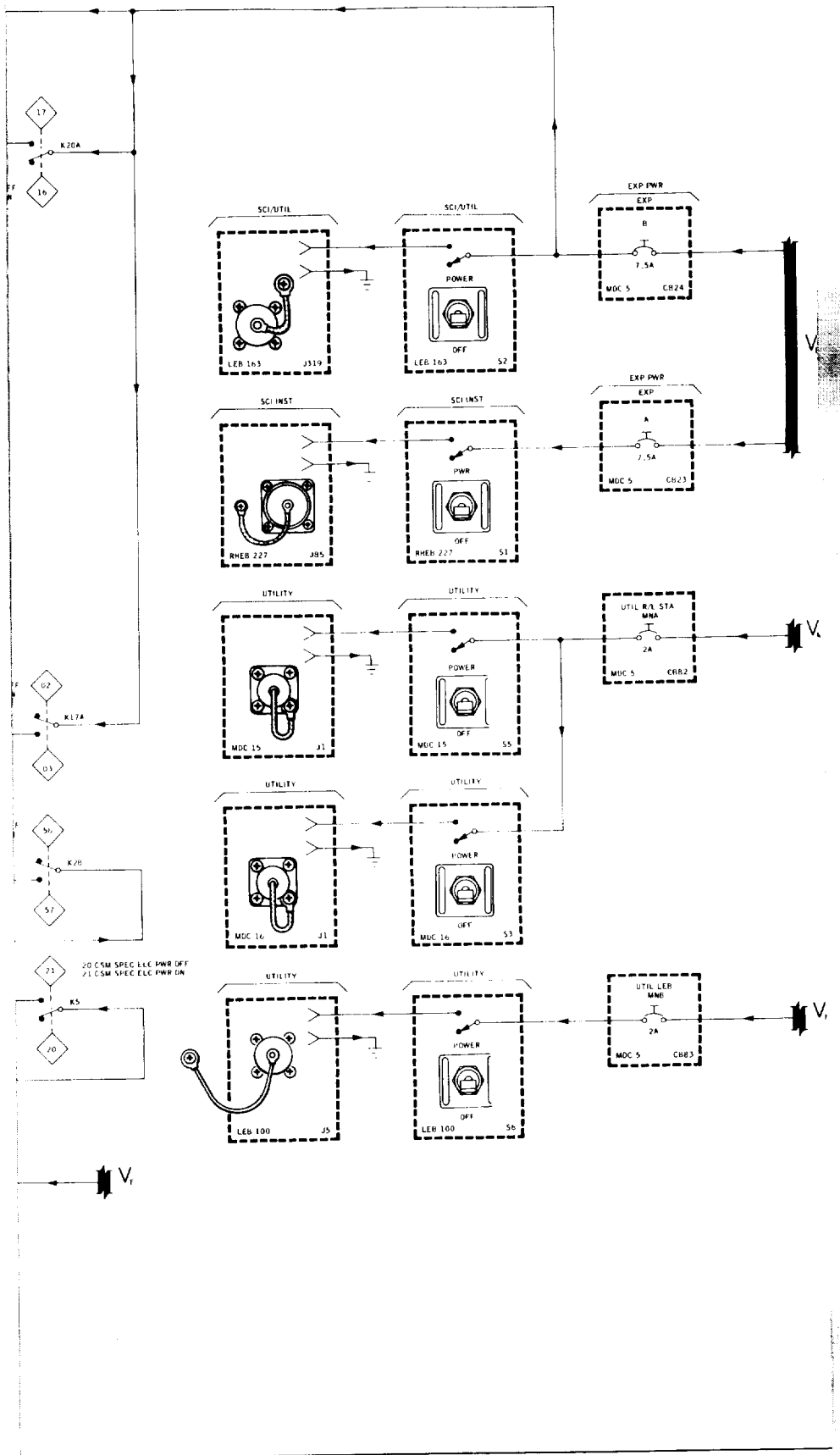

FOLDOUT FRAME 2



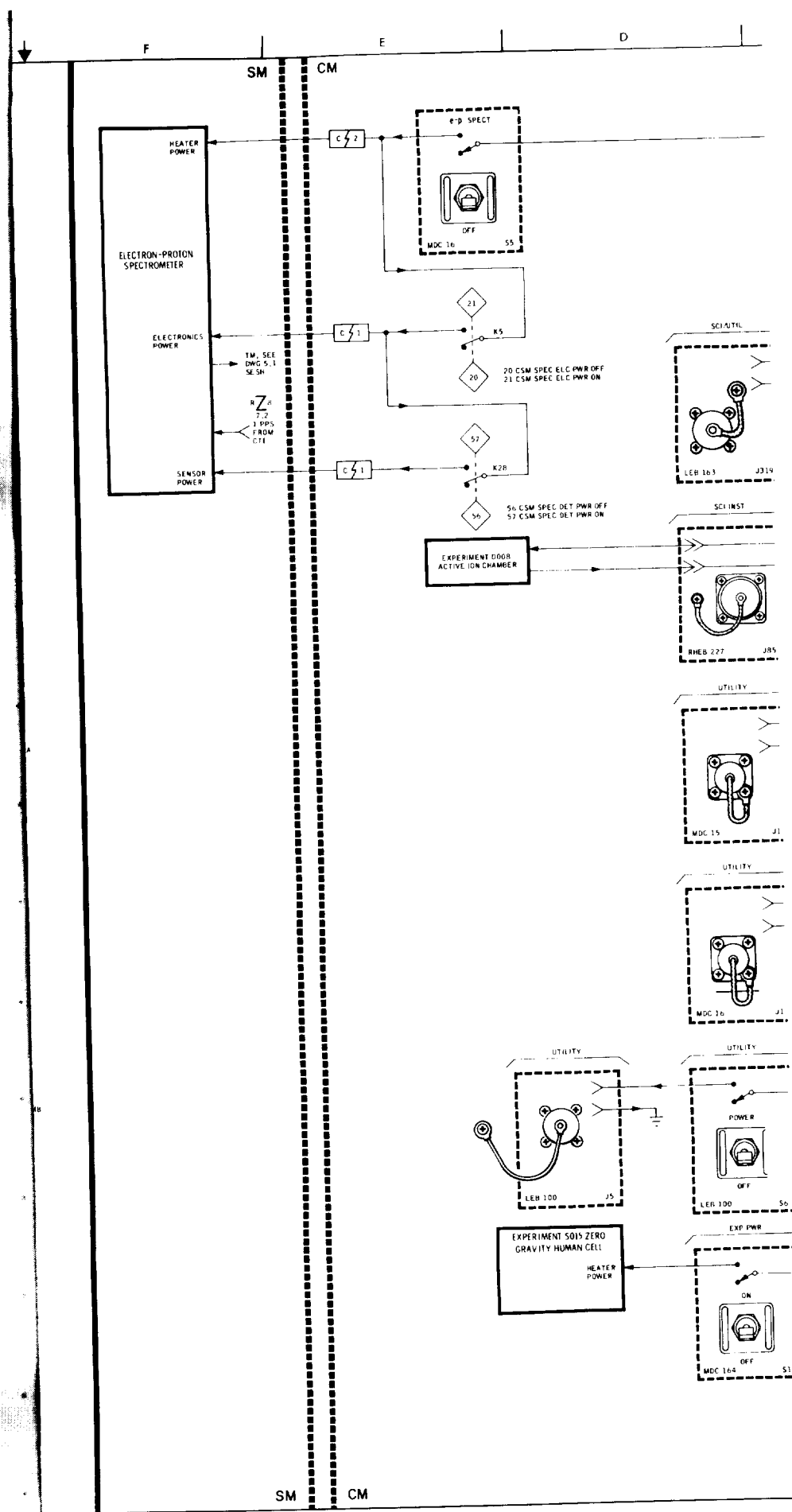



CSM 116

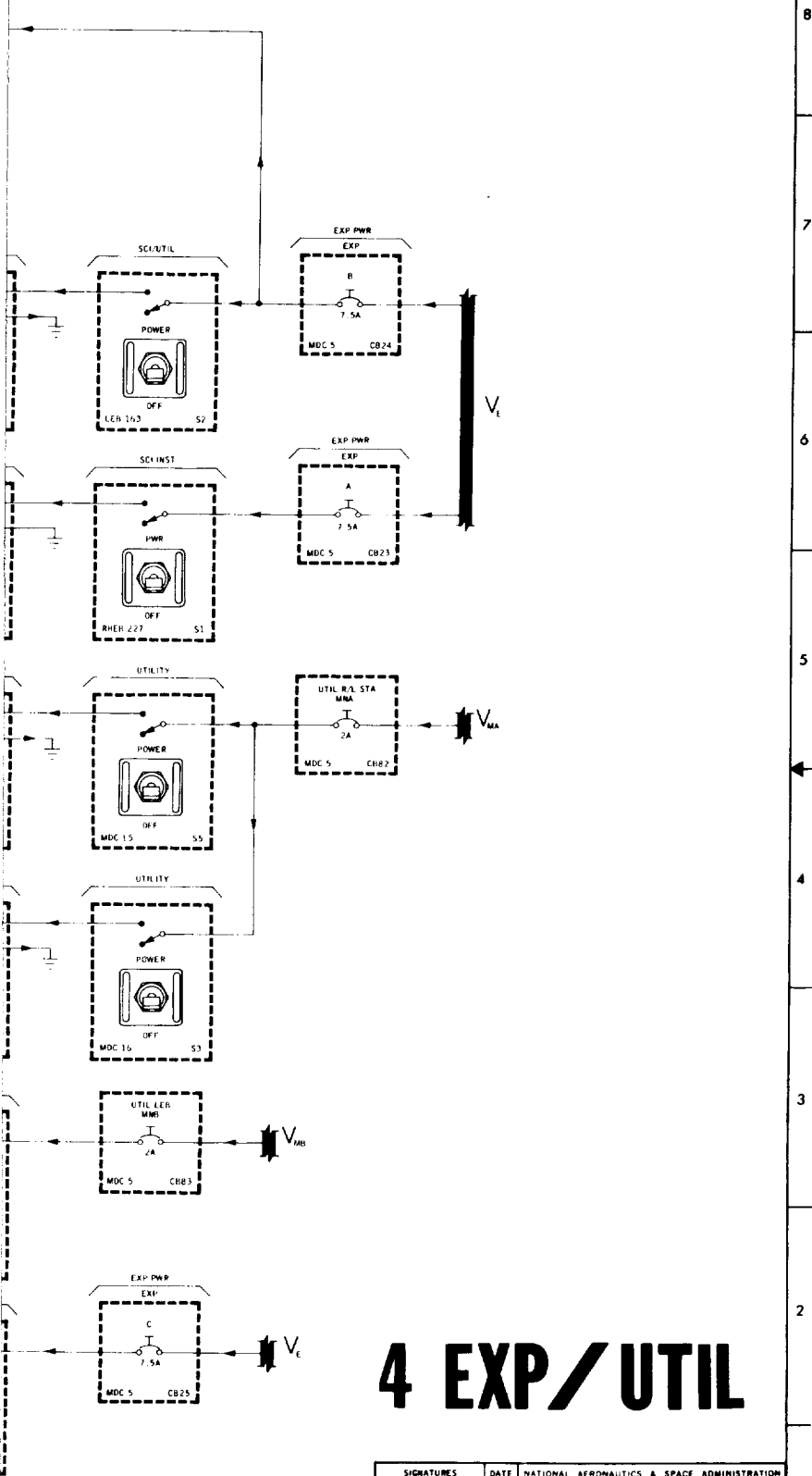

# 4 EXP/UTIL

SIGNATURES		DATE	NATIONAL AERONAUTICS & SPACE ADMINISTRATION	
DR <i>[Signature]</i>		4/17/72	MANNED SPACECRAFT CENTER - HOUSTON, TEXAS	
DSCR <i>[Signature]</i>				
QC				
ENGR <i>[Signature]</i>		4/17/72	<b>EXPERIMENT/UTILITY POWER</b>	
APP <i>[Signature]</i>		4/17/72		
STC <i>[Signature]</i>		4/17/72		
			SKYLAB CSM	DWG NO
			116 THRU 119	<b>3.4</b>
			66 X 34	PAGE 3-4 SHEET 1 OF 1



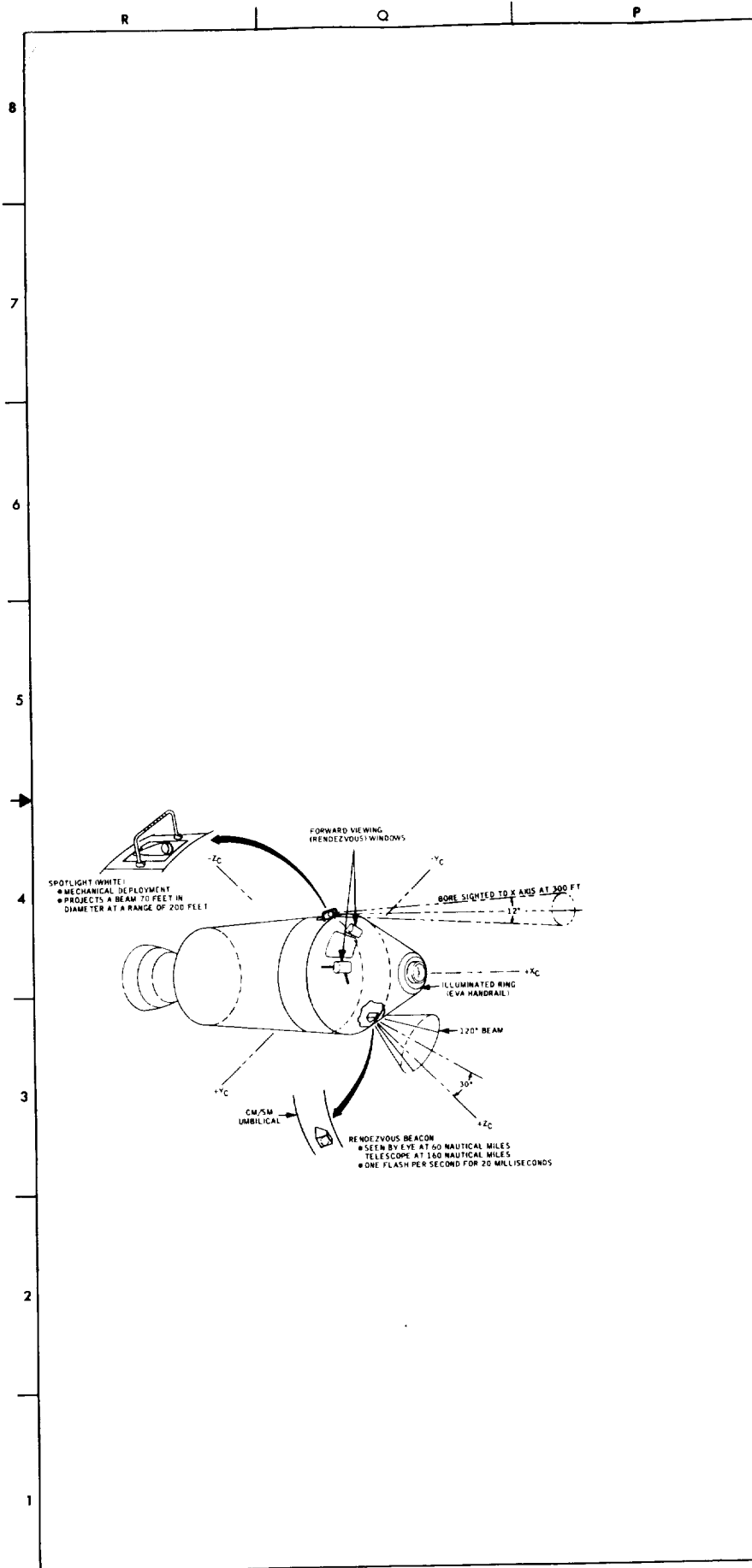

FOLDOUT FRAME 1





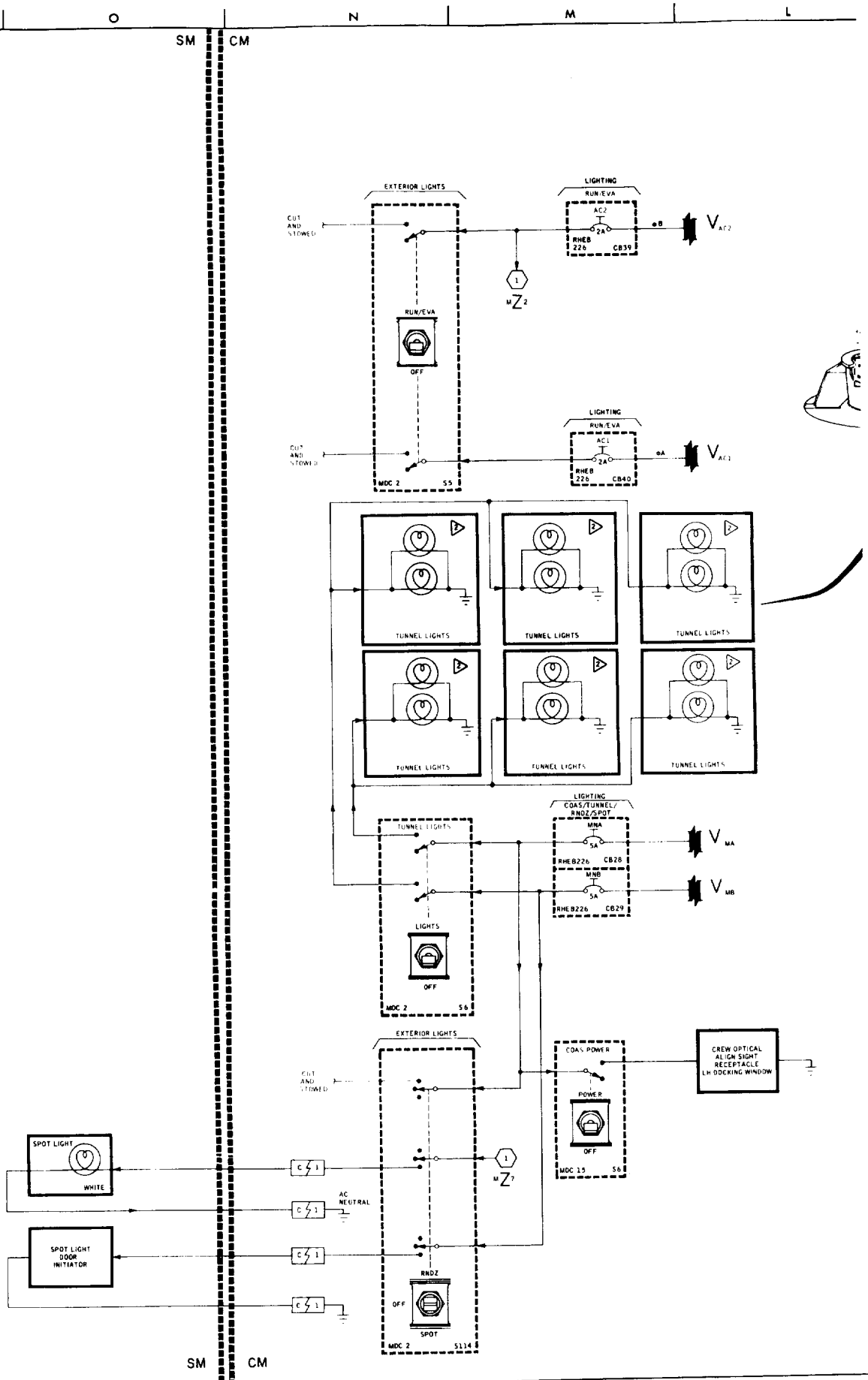

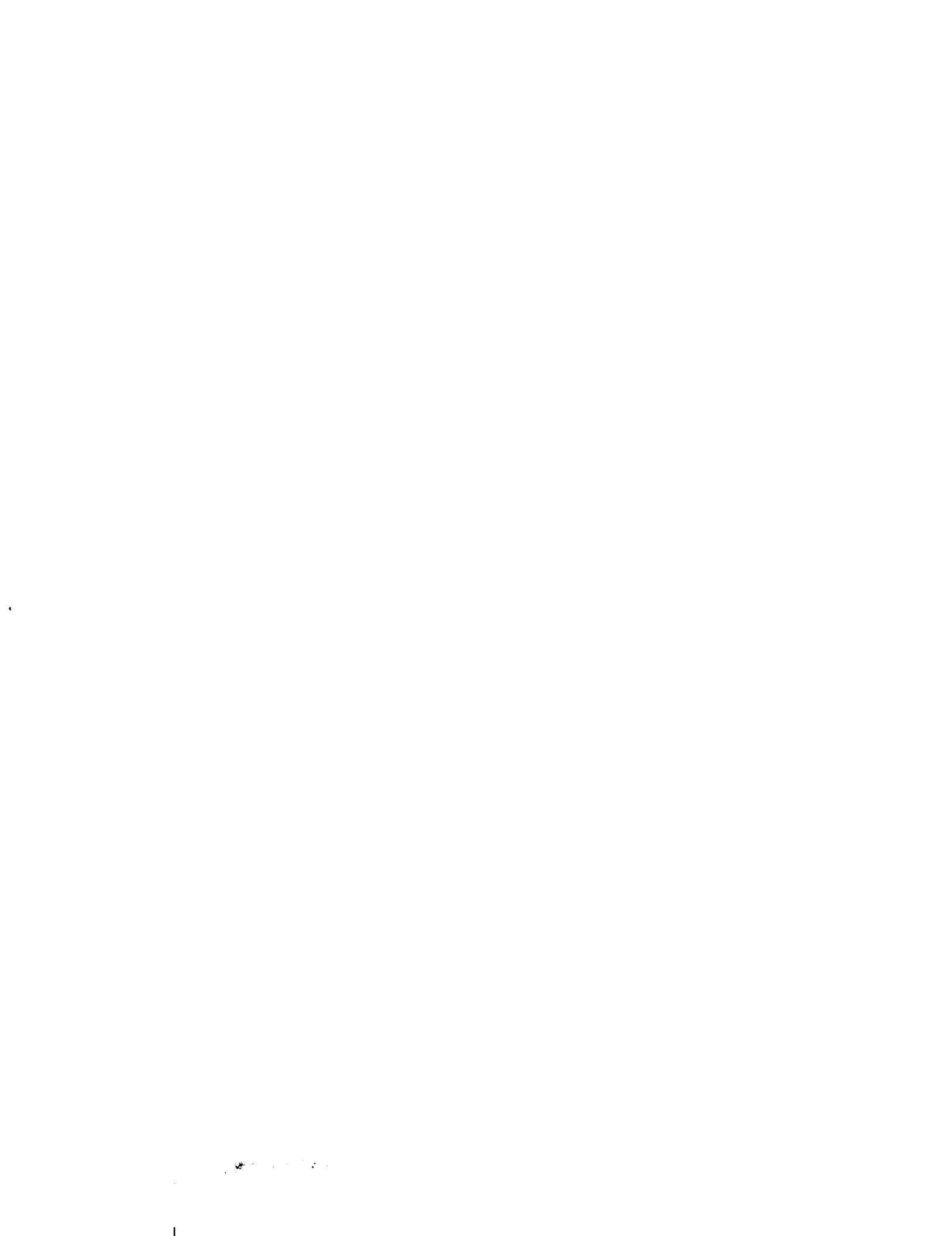

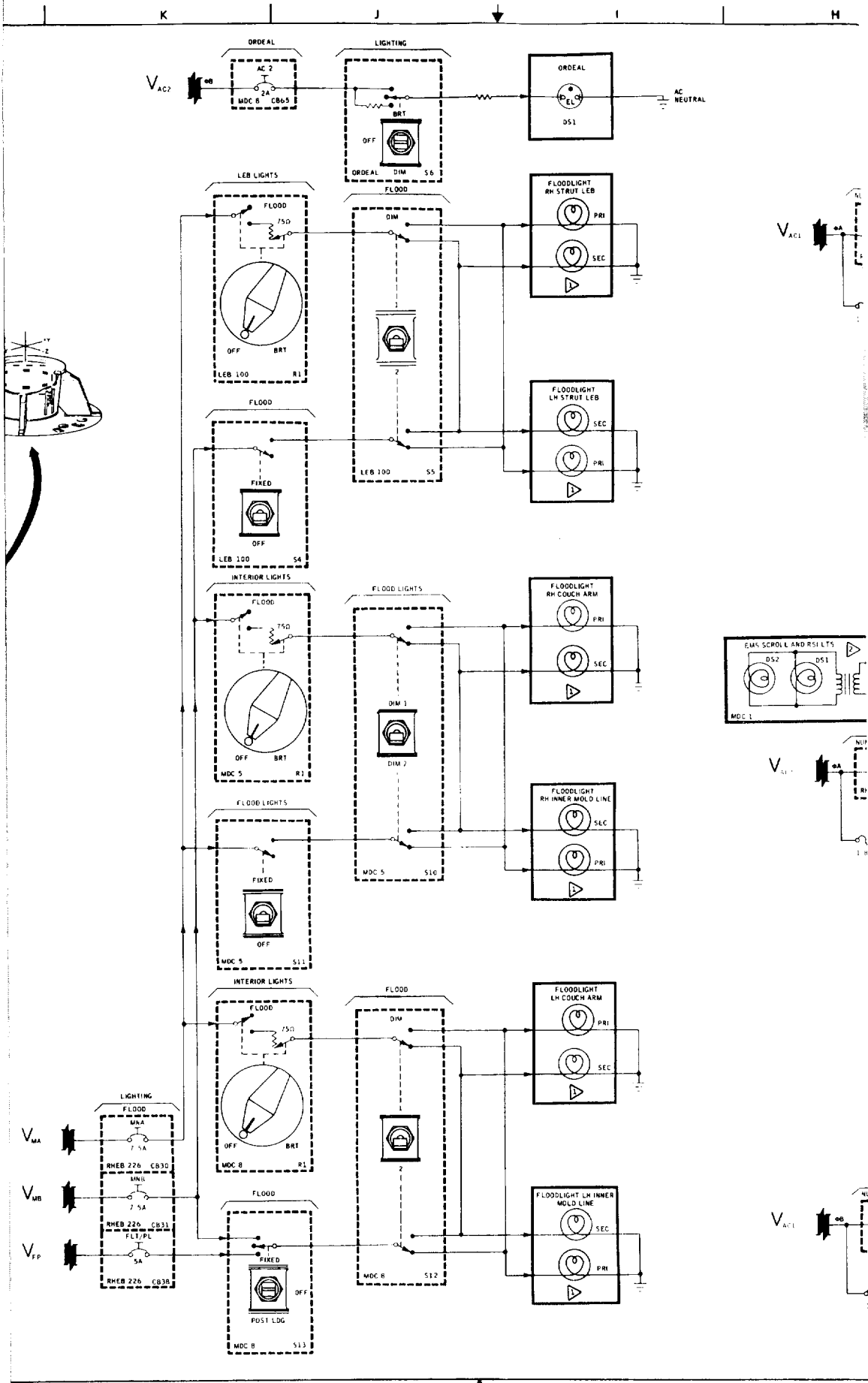

FOLDOUT FRAME 3



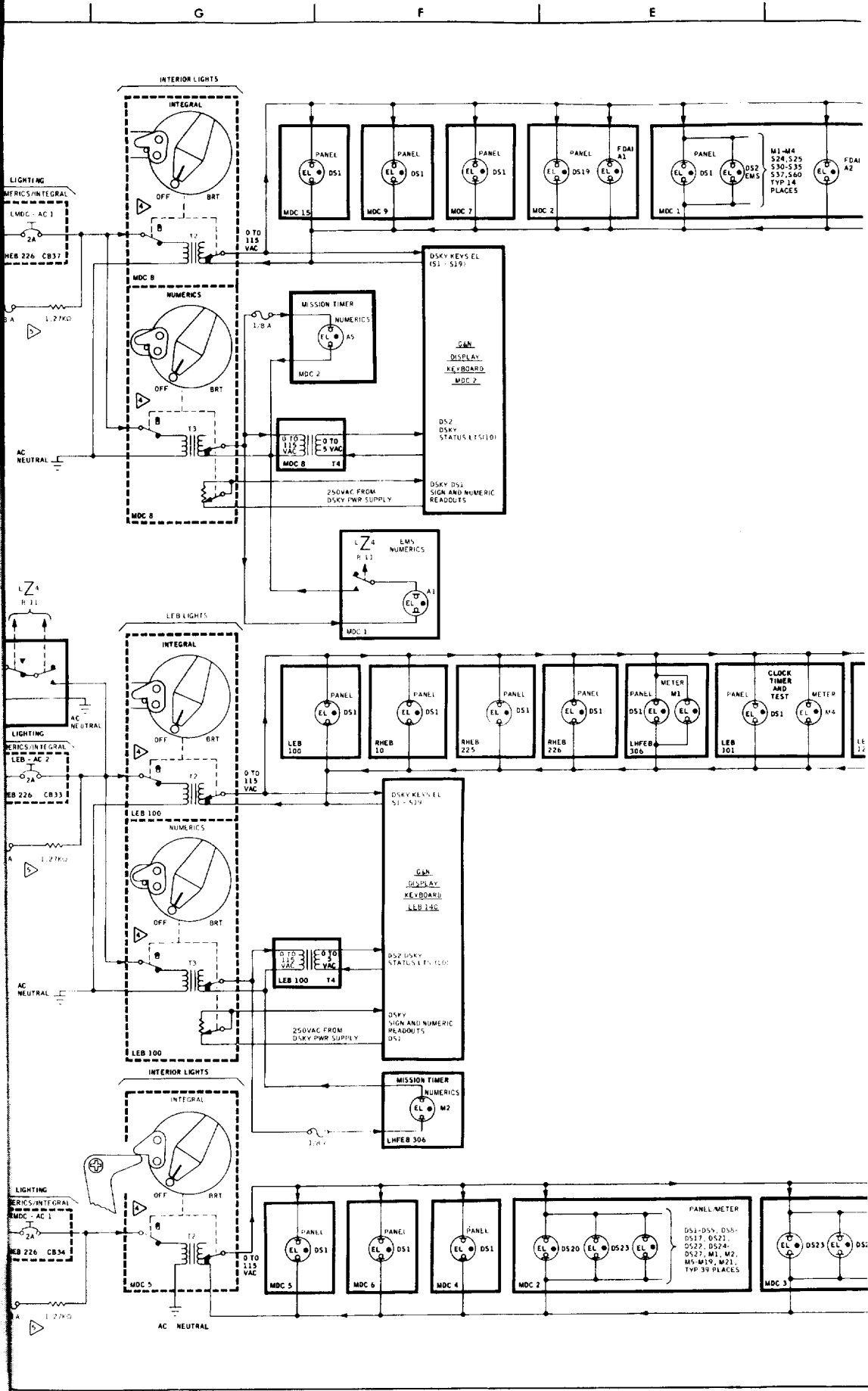

FOLDOUT FRAME 4



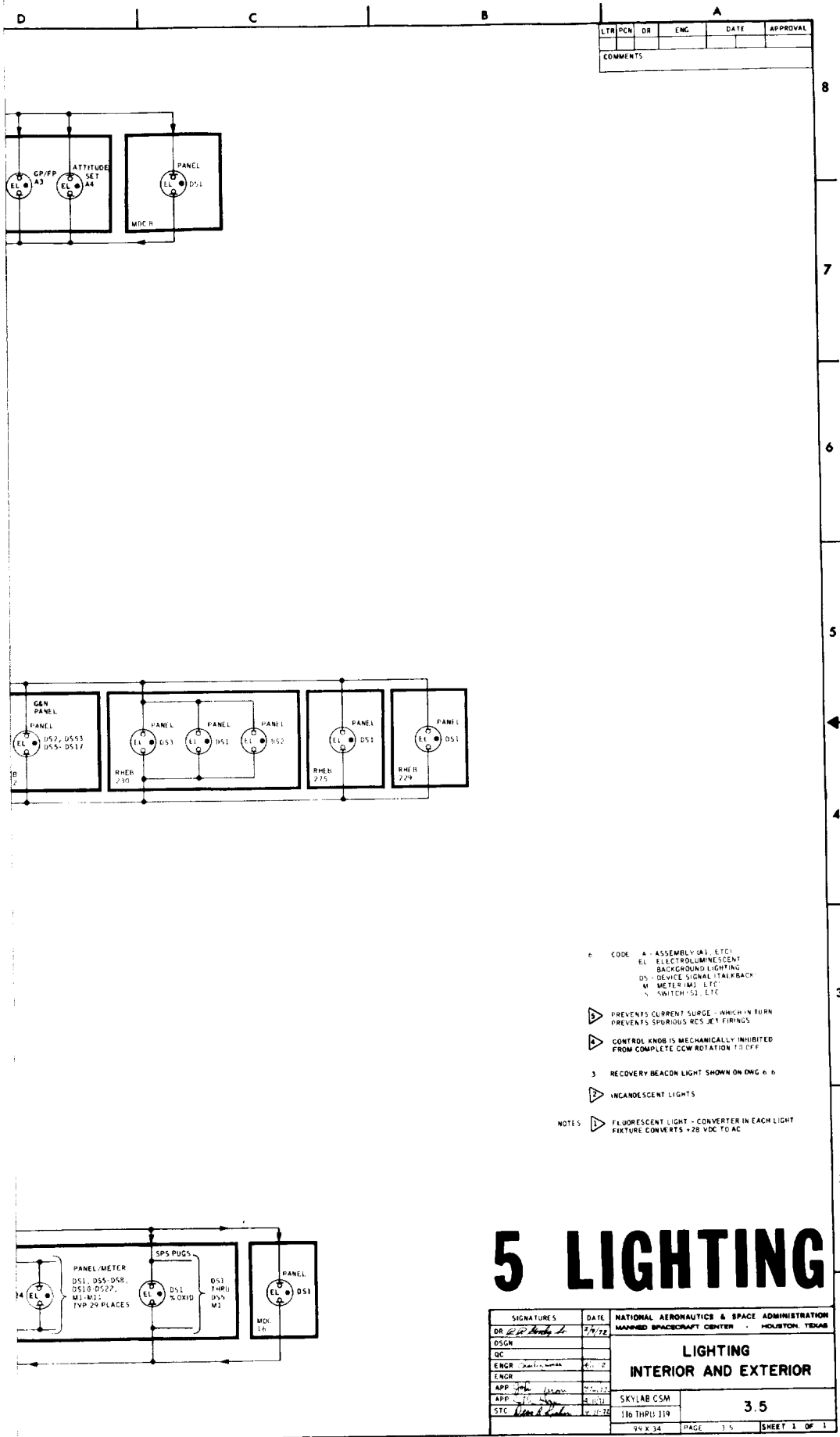

LTR	PKR	DR	ENG	DATE	APPROVAL
COMMENTS					

- 6 CODE A - ASSEMBLY (A1, ETC.)  
EL - ELECTROLUMINESCENT  
BACKGROUND LIGHTING  
DS - DEVICE SIGNAL (TALKBACK,  
M - METER (M) ETC.  
S - SWITCH (S) ETC.
- ▷ PREVENTS CURRENT SURGE - WHICH IN TURN  
PREVENTS SPURIOUS RCS JET FIRINGS
- ▷ CONTROL KNOB IS MECHANICALLY INHIBITED  
FROM COMPLETE CCW ROTATION TO OFF
- 3 RECOVERY BEACON LIGHT SHOWN ON DNG 6.6
- ▷ INCANDESCENT LIGHTS
- NOTES ▷ FLUORESCENT LIGHT - CONVERTER IN EACH LIGHT  
FIXTURE CONVERTS +28 VDC TO AC

# 5 LIGHTING

SIGNATURES		DATE	NATIONAL AERONAUTICS & SPACE ADMINISTRATION	
DR	<i>R. P. Smith, Jr.</i>	7/9/72	MANNED SPACECRAFT CENTER - HOUSTON, TEXAS	
DSCN				
QC				
ENGR	<i>James L. ...</i>	6/11/72		
ENGR				
APP	<i>...</i>	7/20/72		
APP	<i>...</i>	8/11/72	SKYLAB CSM	
STC	<i>...</i>	8/11/72	116 THRU 119	
			44 X 34	PAGE 15 SHEET 1 OF 1





5

—

4

—

3

—

2

—

1

**FOLDOUT FRAME** |

1000

F

E

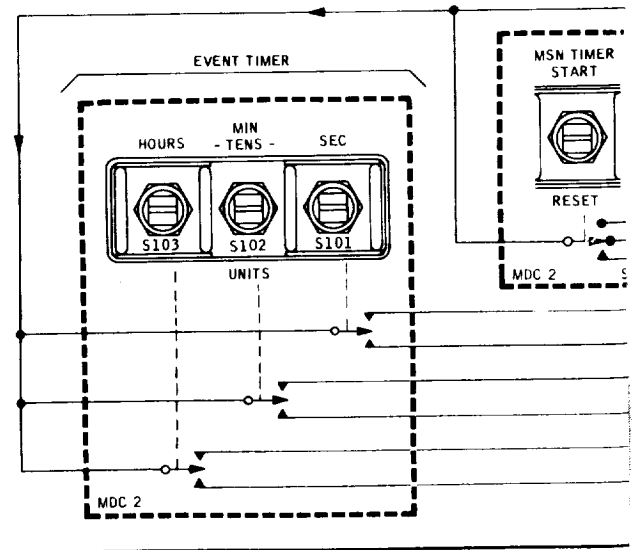
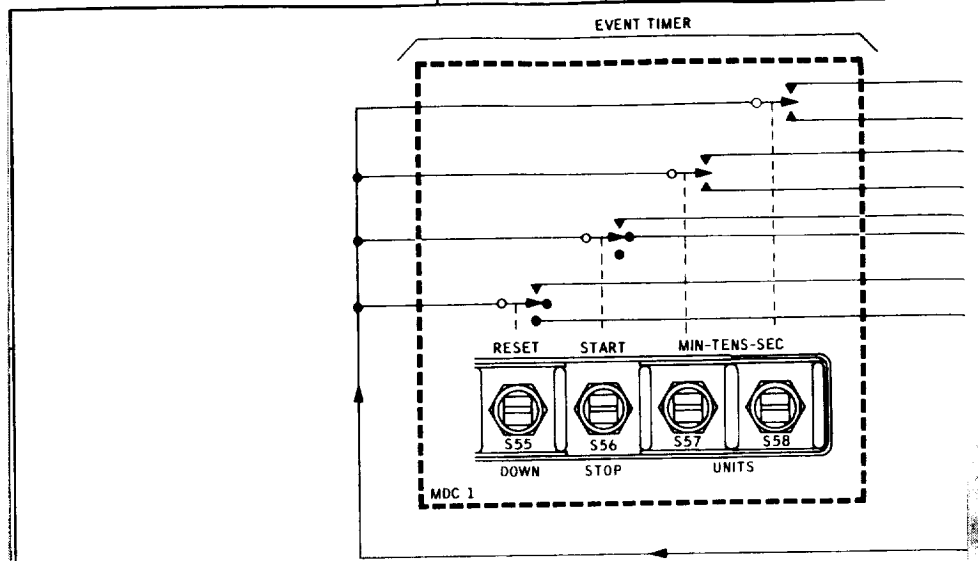

FOLDOUT FRAME 2



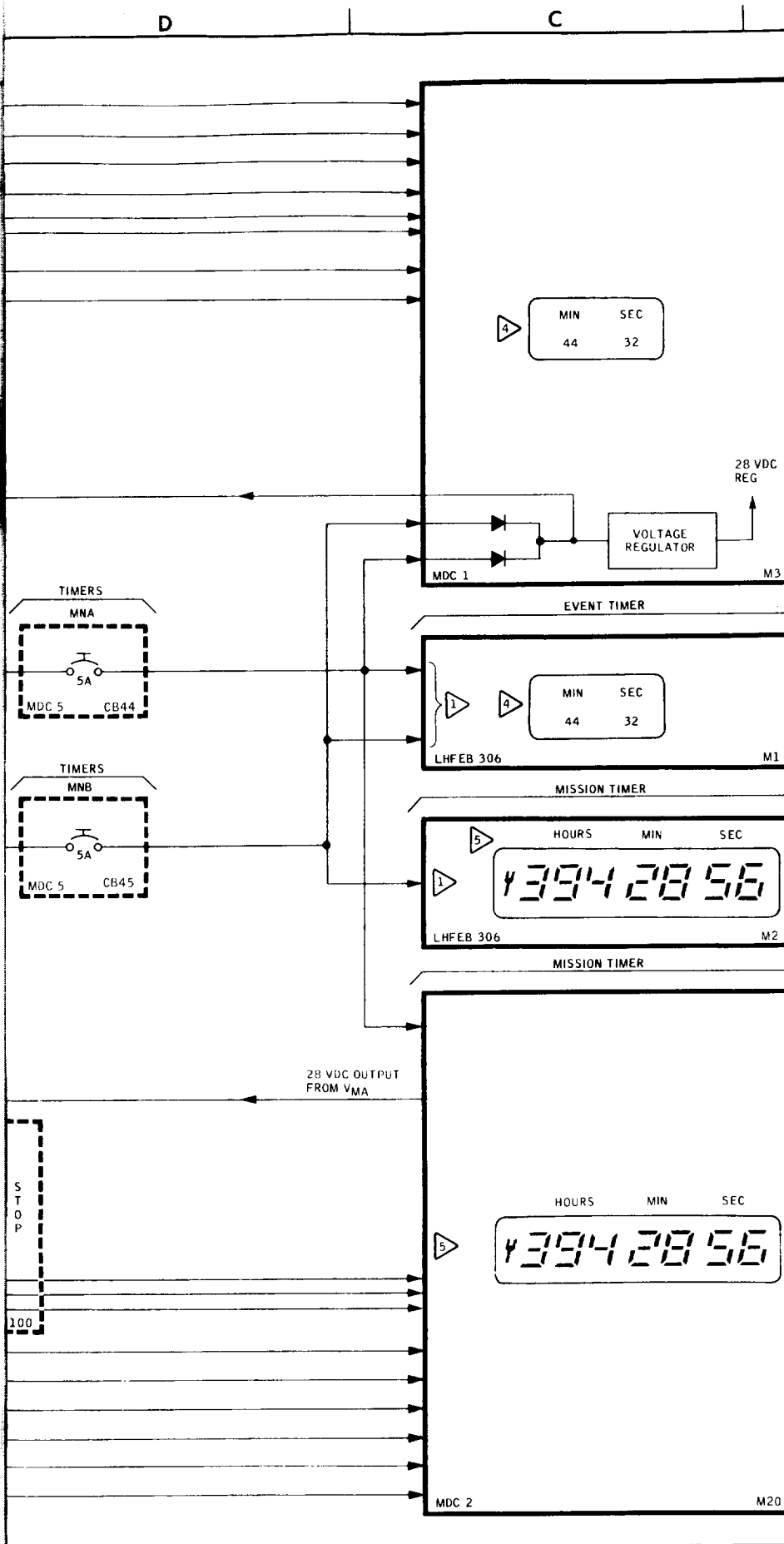



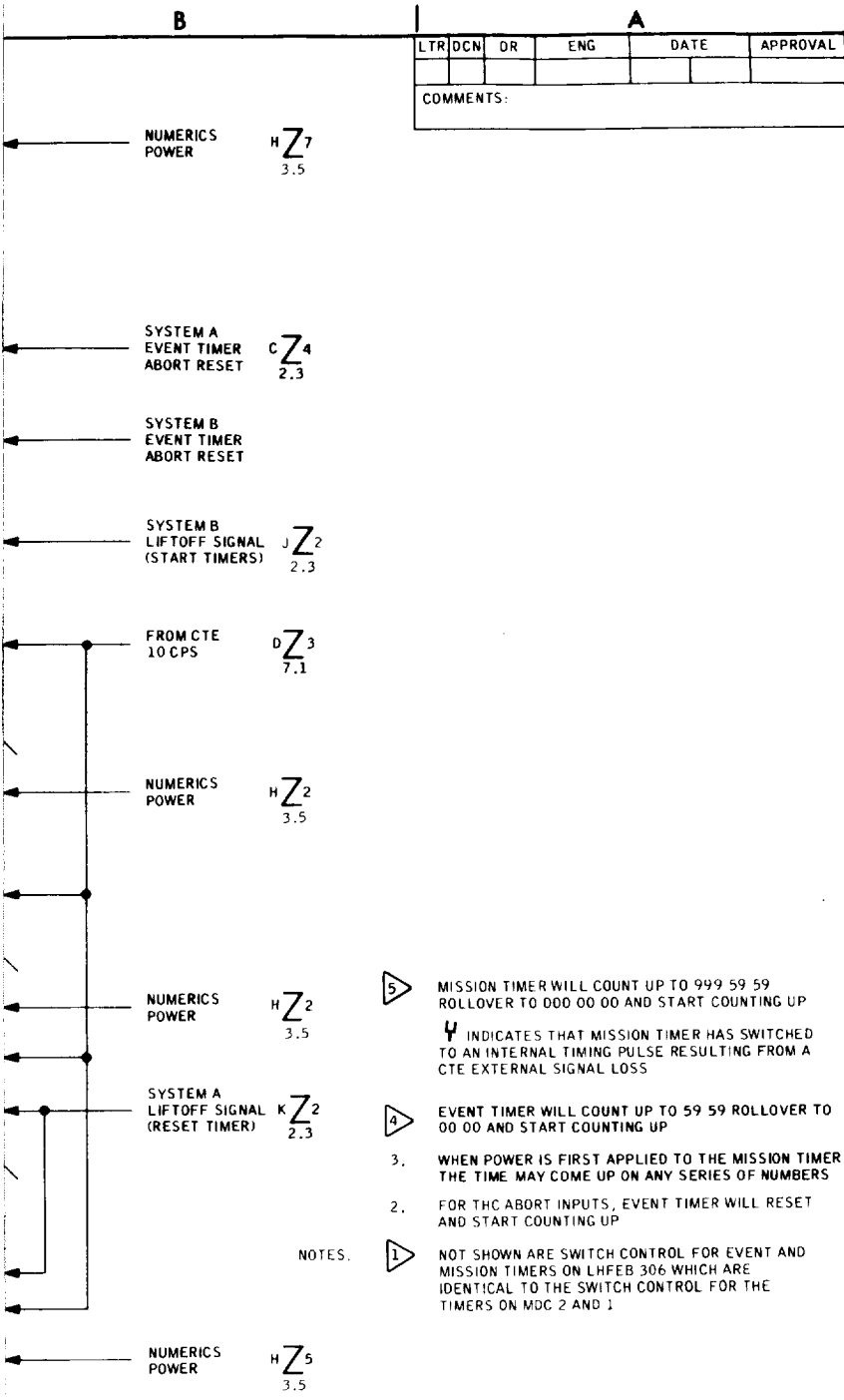

# 6 TIMER

SIGNATURES	DATE	NATIONAL AERONAUTICS & SPACE ADMINISTRATION MANNED SPACECRAFT CENTER · HOUSTON, TEXAS			
DR		<b>TIMER CONTROL</b>			
DSGN					
QC					
ENGR <i>Charlie Jones</i>	4/11/72				
ENGR					
APP <i>John Canon</i>	4/11/72	SKYLAB CSM	DWG NO	<b>3.6</b>	
APP <i>JR Spivey</i>	4/11/72				
STC <i>Don A. Risher</i>	4-11-72	116 THRU 119			
		34 X 22	PAGE 3-6	SHEET 1 OF 1	

FOLDOUT FRAME 4

10/10/2020



		H					G					F					E												
		SYSTEMS TEST METER DISPLAYS (VOLTS)																											
		0.0	0.2	0.4	0.6	0.8	1.0	1.2	1.4	1.6	1.8	2.0	2.2	2.4	2.6	2.8	3.0	3.2	3.4	3.6	3.8	4.0	4.2	4.4	4.6	4.8	5.0		
8																													
7																													
6																													
5																													
4																													
3																													
2																													
1																													

- O<sub>2</sub> TANK 2 HTR TEMP
- O<sub>2</sub> TANK 1 HTR TEMP
- SPS OXID TANK OUTBD TEMP
- SPS FUEL CHECK VLV TEMP
- SPS OXID FEED LINE TEMP
- SPS ENGL VLV BODY TEMP
- SM RCS PRI TANK TEMP
- SM RCS PSM 3 FUEL TANK TEMP
- CM RCS ENGL VLV TEMP
- BAT RELAY BUS VOLTAGE
- BAT COMPT PRESS
- FUEL CELL RAD OUT TEMP
- FUEL CELL PRESSURE

FOLDOUT FRAME /



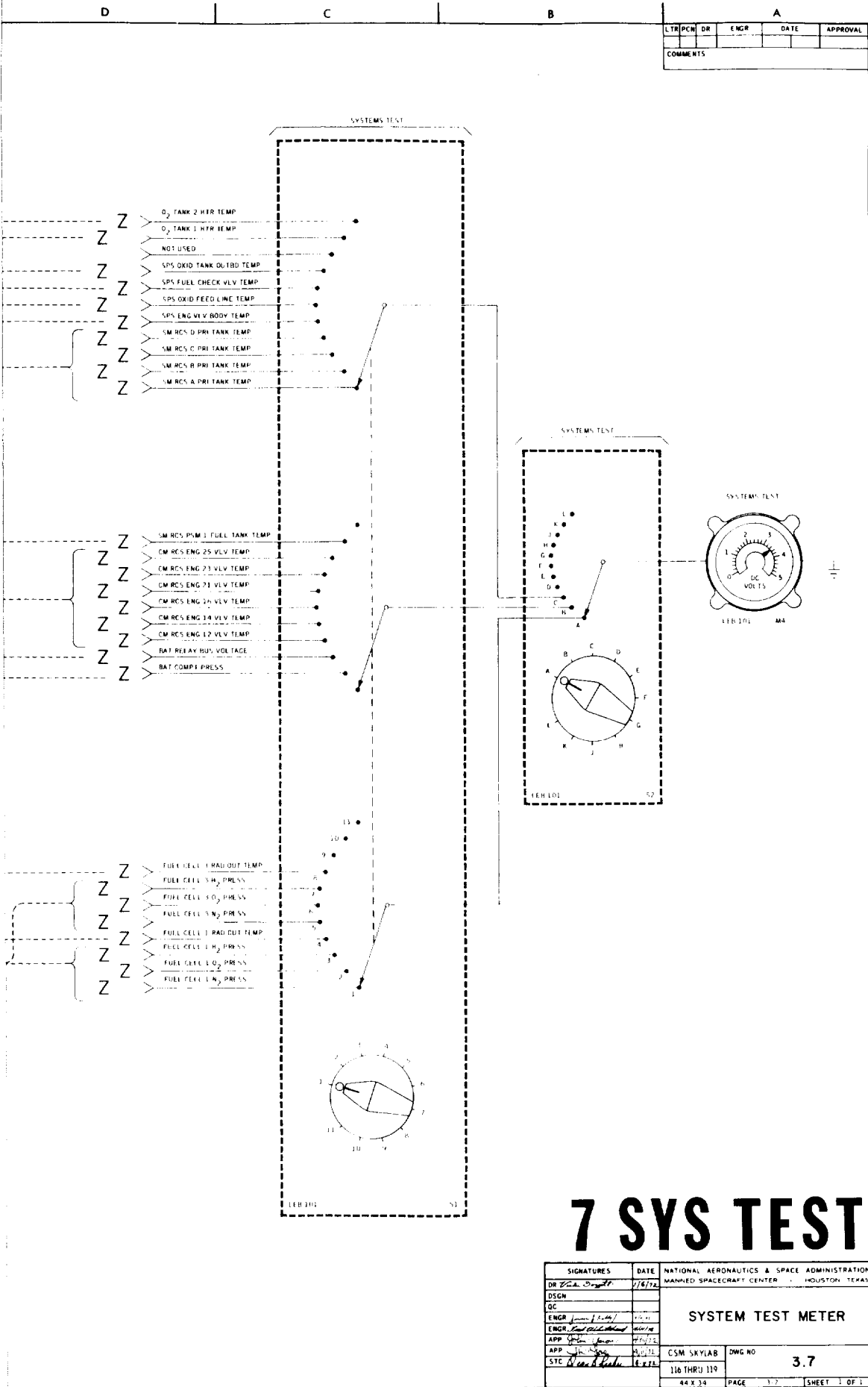

# 7 SYS TEST

SIGNATURES		DATE	NATIONAL AERONAUTICS & SPACE ADMINISTRATION MANNED SPACECRAFT CENTER HOUSTON TEXAS	
DR	<i>[Signature]</i>	1/6/72	SYSTEM TEST METER	
DSGN				
QC				
ENGR	<i>[Signature]</i>	1/6/72		
APP	<i>[Signature]</i>	1/6/72		
STC	<i>[Signature]</i>	1/6/72	CSM SKYLAB	DWG NO
			116 THRU 119	3.7
			44 X 34	PAGE 3.7 SHEET 1 OF 1

EOLDOUT FRAME *[Handwritten mark]*



4 ENVIRONMENTAL  
CONTROL SYS

)

)

)

)

)

1000

|

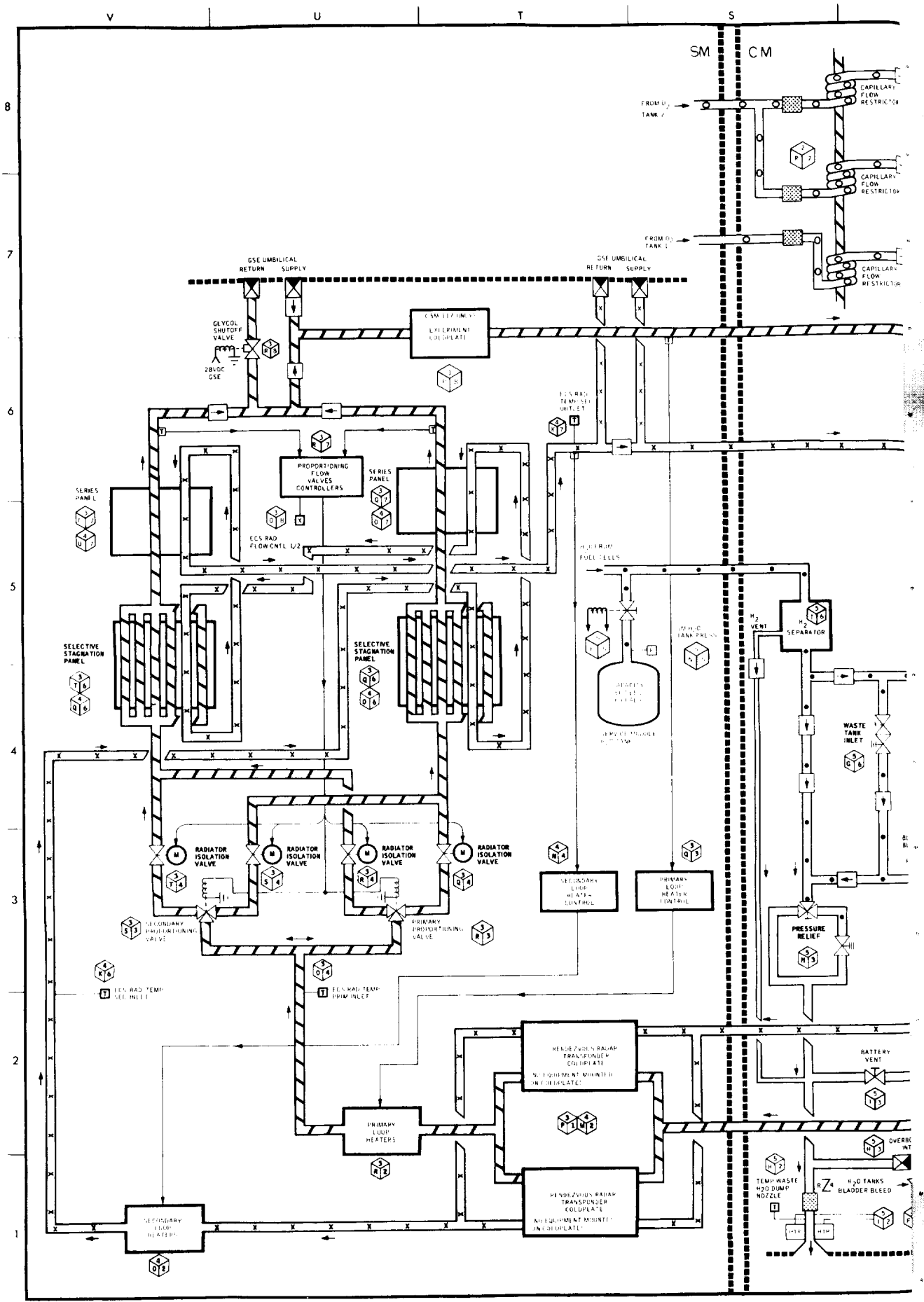

**FOLDOUT FRAME 1**





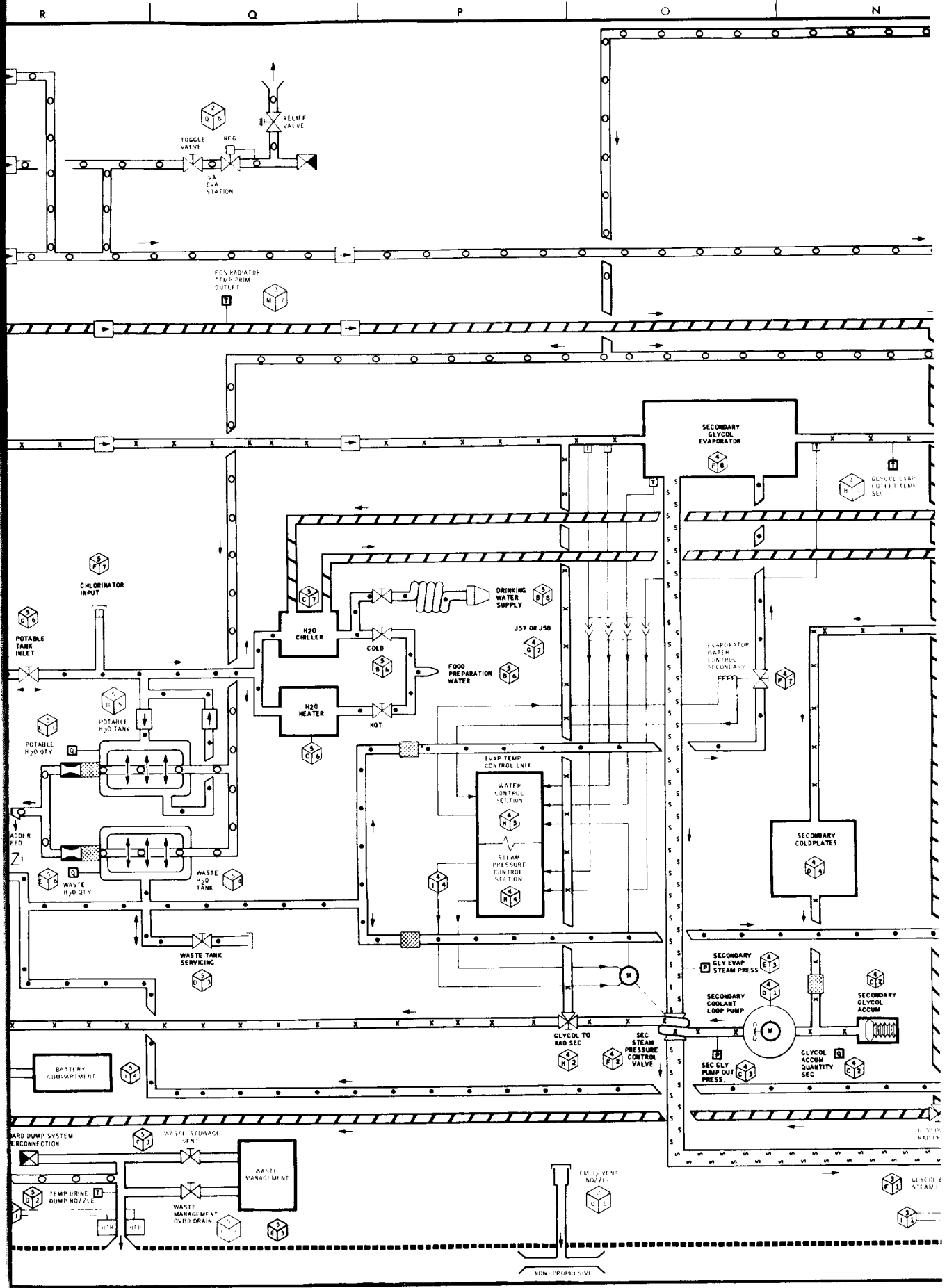

FOLDOUT FRAME 2



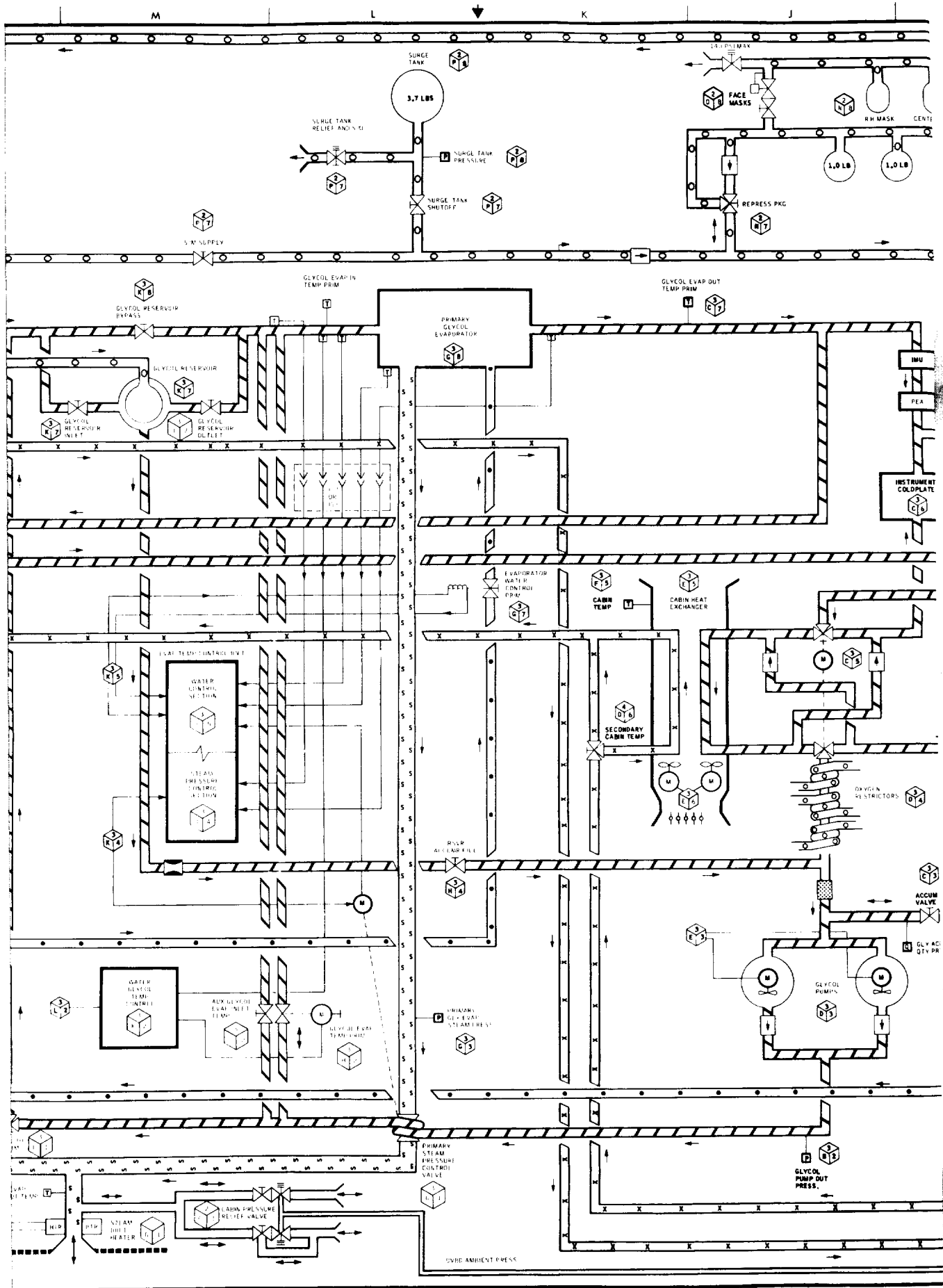

FOLDOUT FRAME 3



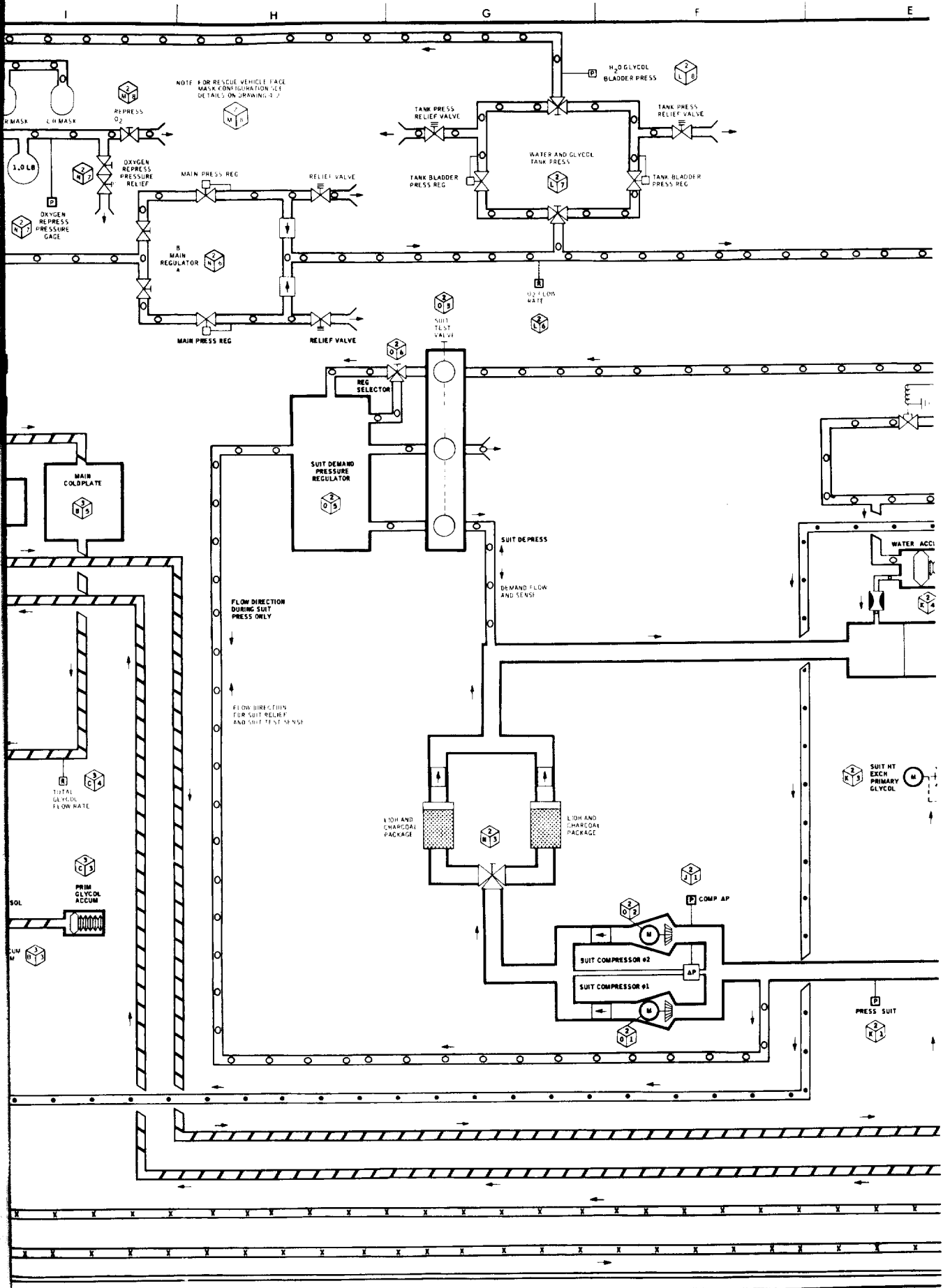

FOLDOUT FRAME 4



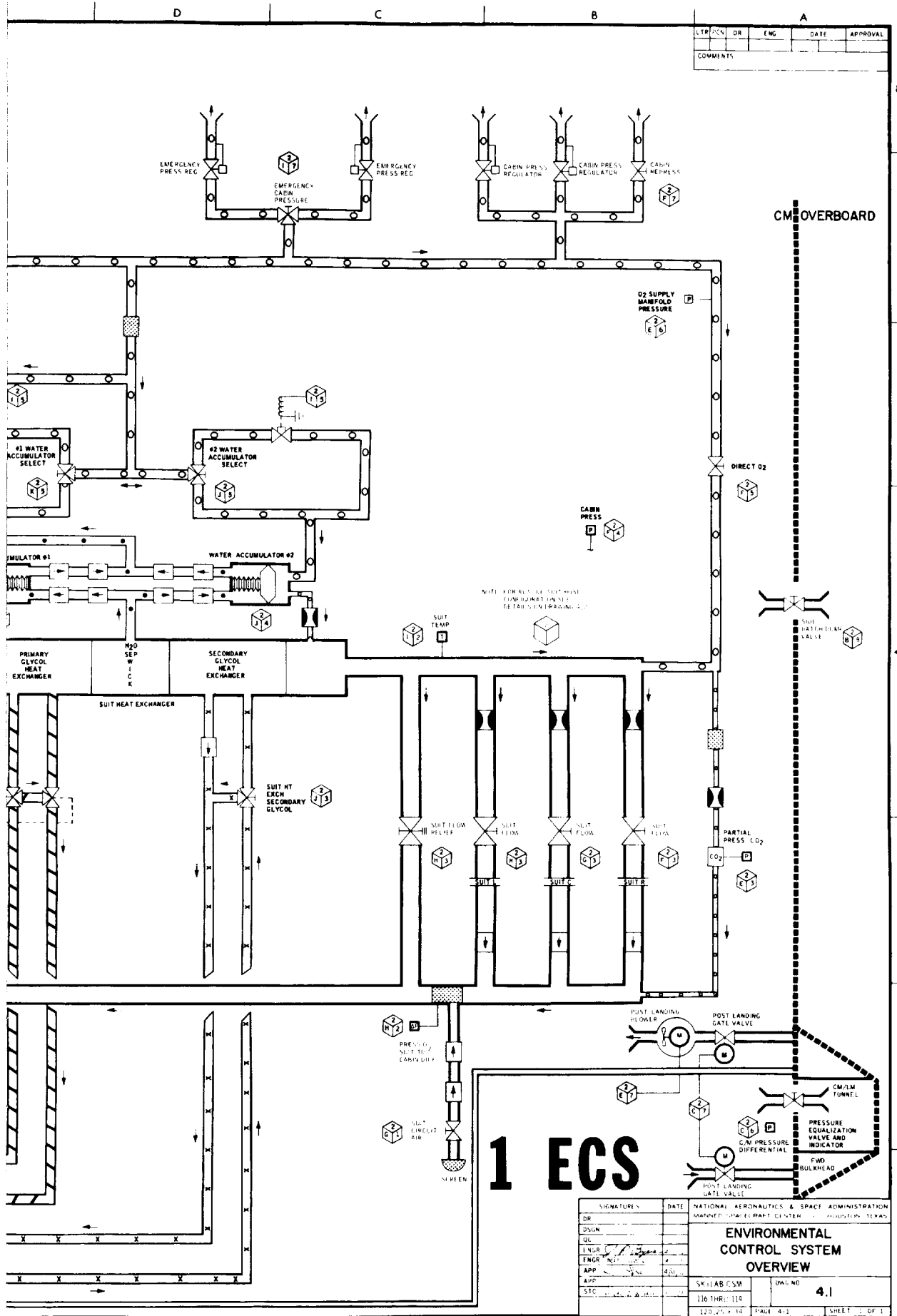

LT/PS	DR	ENG	DATE	APPROVAL
COMMENTS				

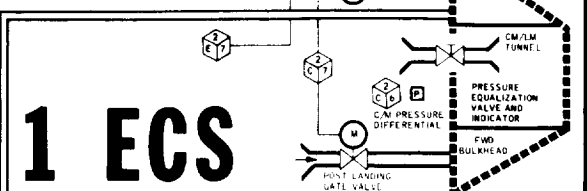

# 1 ECS

SIGNATURES		DATE	NATIONAL AERONAUTICS & SPACE ADMINISTRATION	
DR			MARSHALL SPACE FLIGHT CENTER, HOUSTON, TEXAS	
ENGR			<b>ENVIRONMENTAL CONTROL SYSTEM OVERVIEW</b>	
APP				
STC				
SKYLAB/CSM		UPL NO	4.1	
116 THR: 118		120, 25 x 142		PAGE 4-1 SHEET 1 OF 1

FOLDOUT FRAME 5





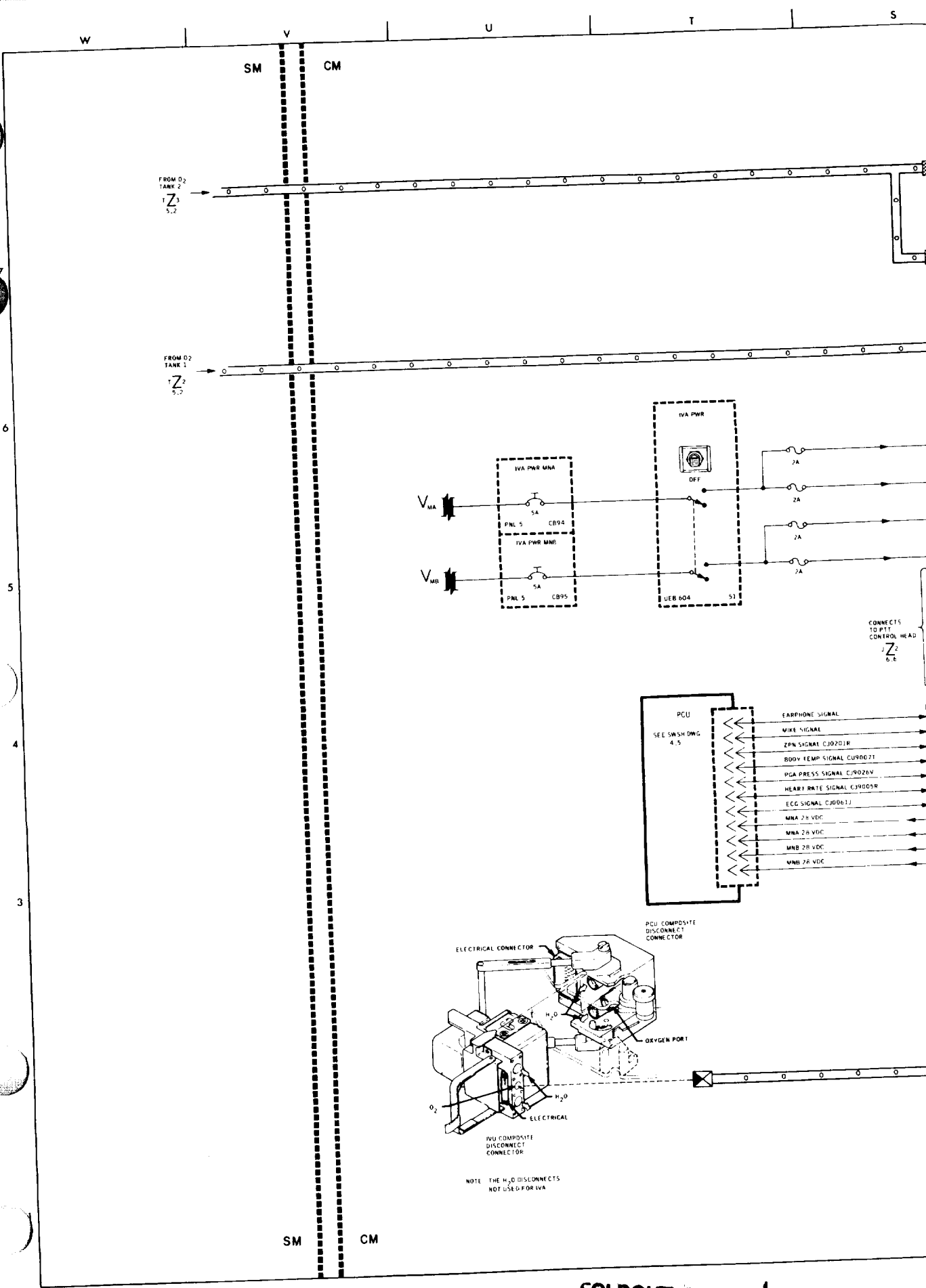

FROM O<sub>2</sub>  
TANK 2  
Z 3  
5.2

FROM O<sub>2</sub>  
TANK 1  
Z 2  
5.2

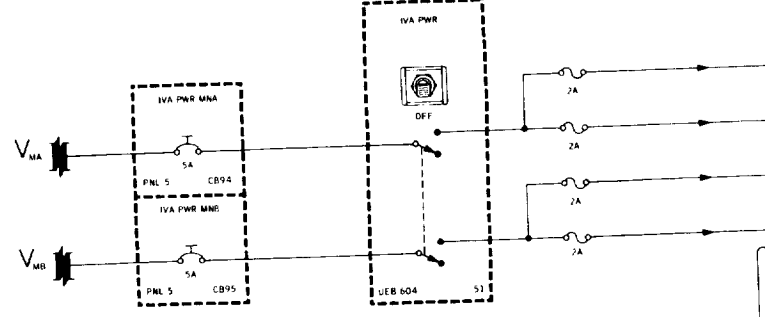

CONNECTS  
TO PT11  
CONTROL HEAD  
Z 2  
5.2

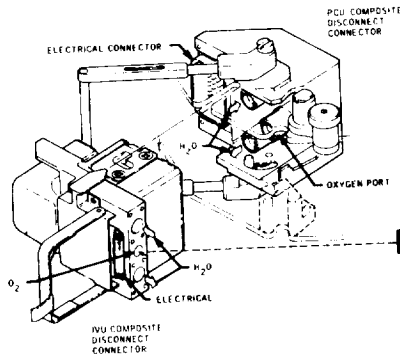
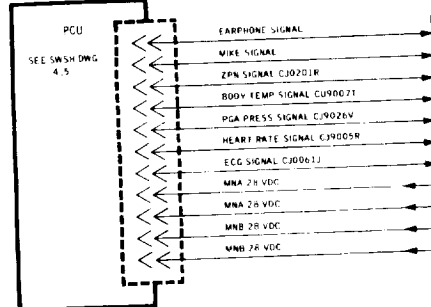

NOTE THE H<sub>2</sub>O DISCONNECTS  
NOT USED FOR IVA

**FOLDOUT FRAME**



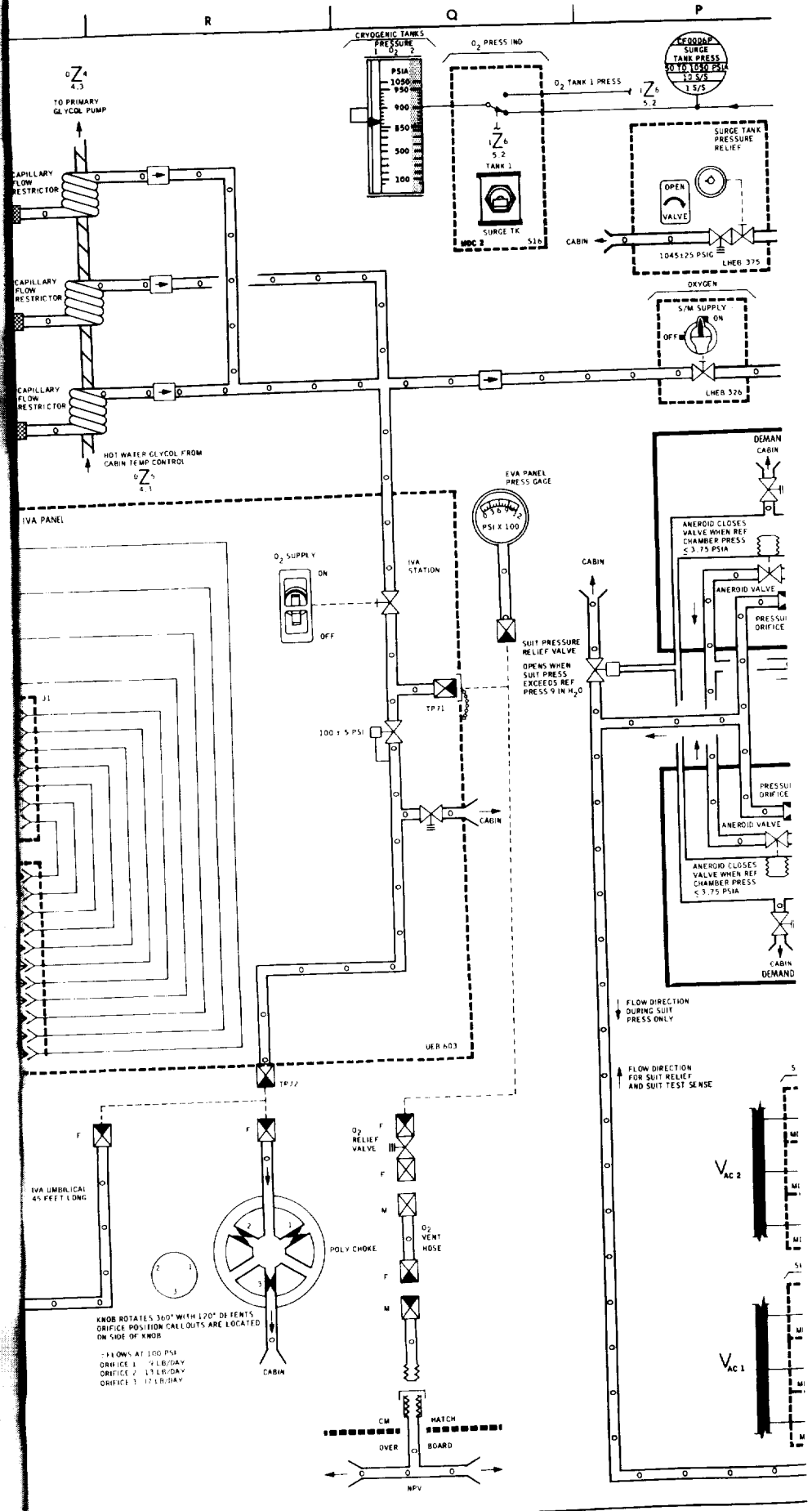



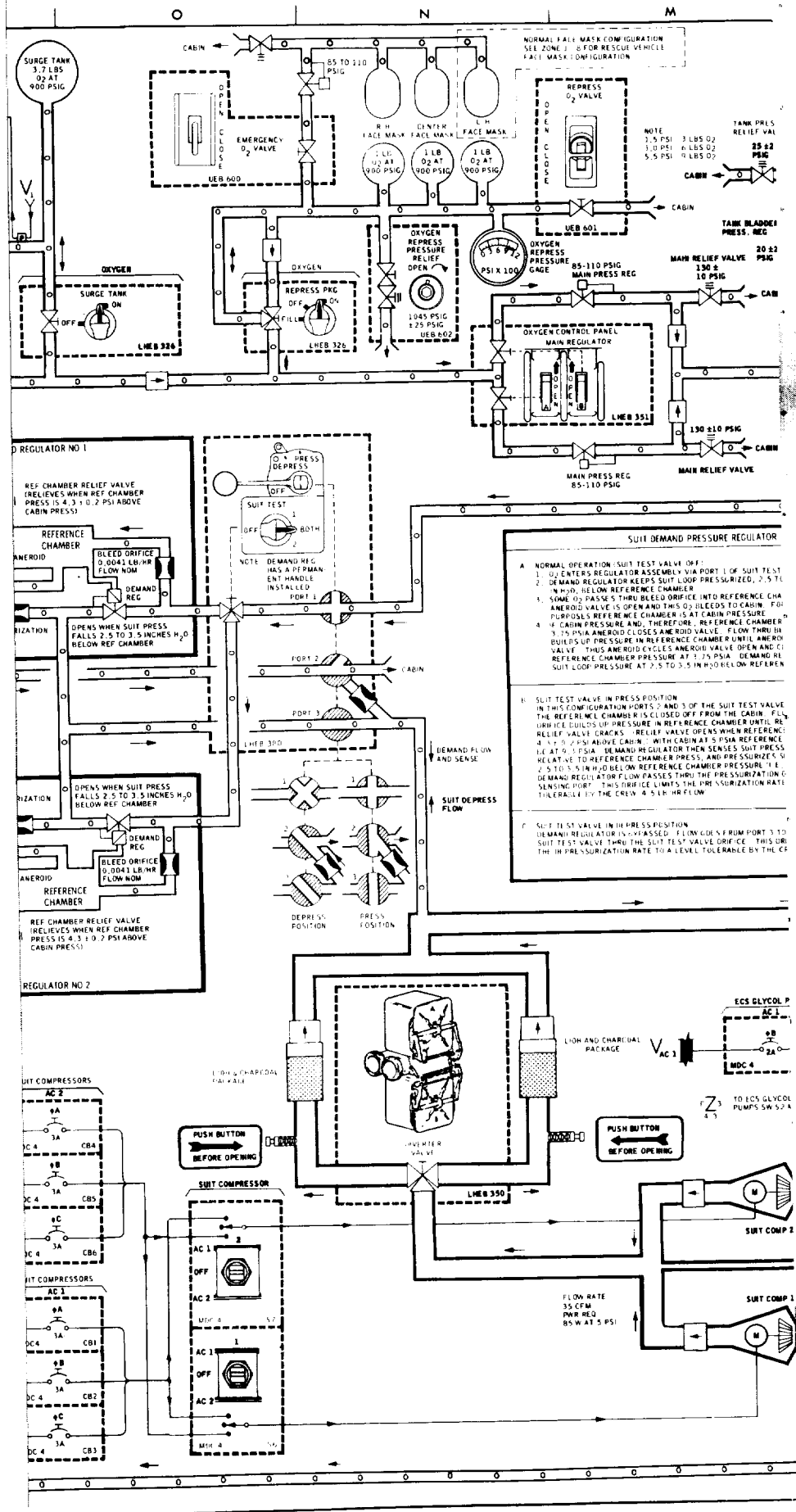

FOLDOUT FRAME 3



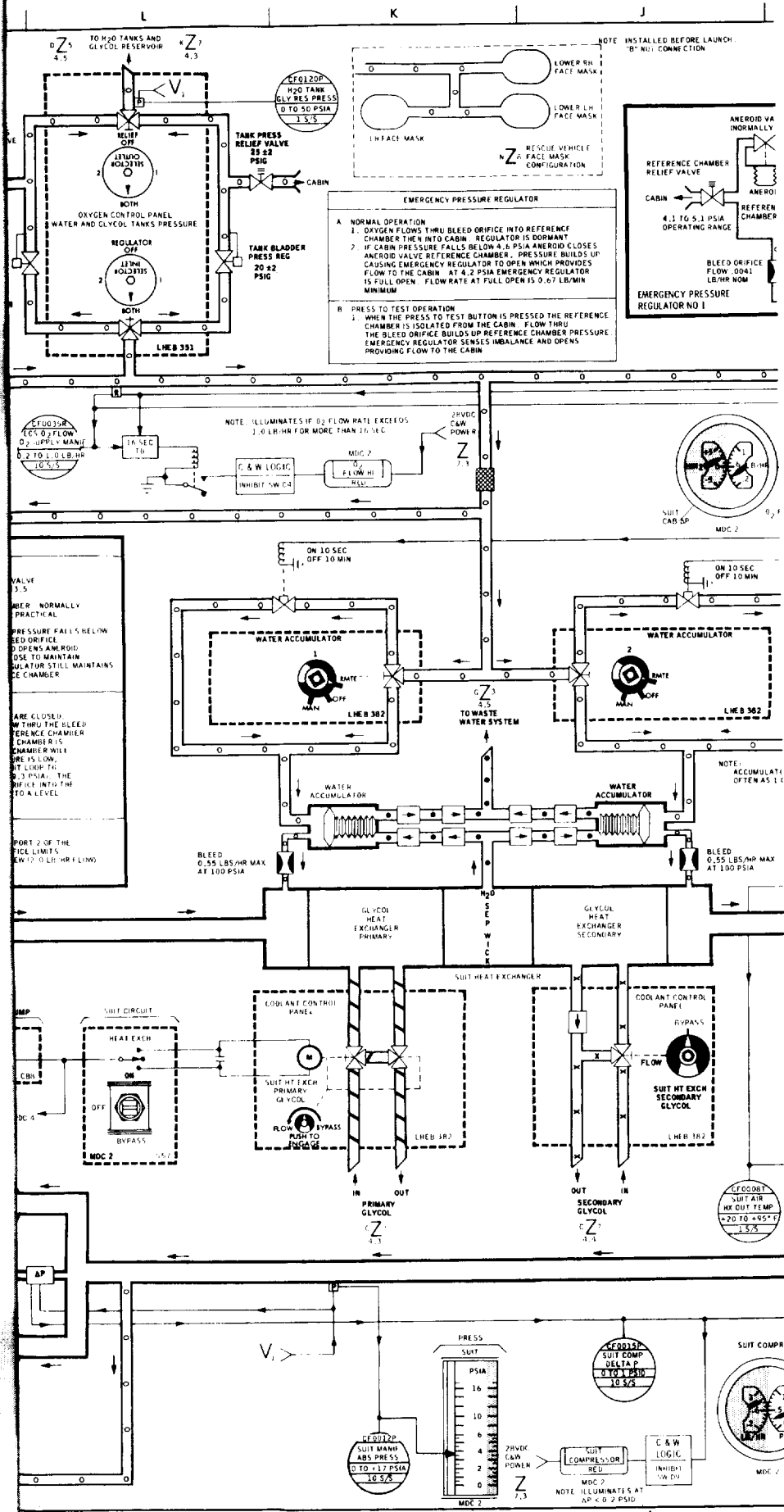

FOLDOUT FRAME 4





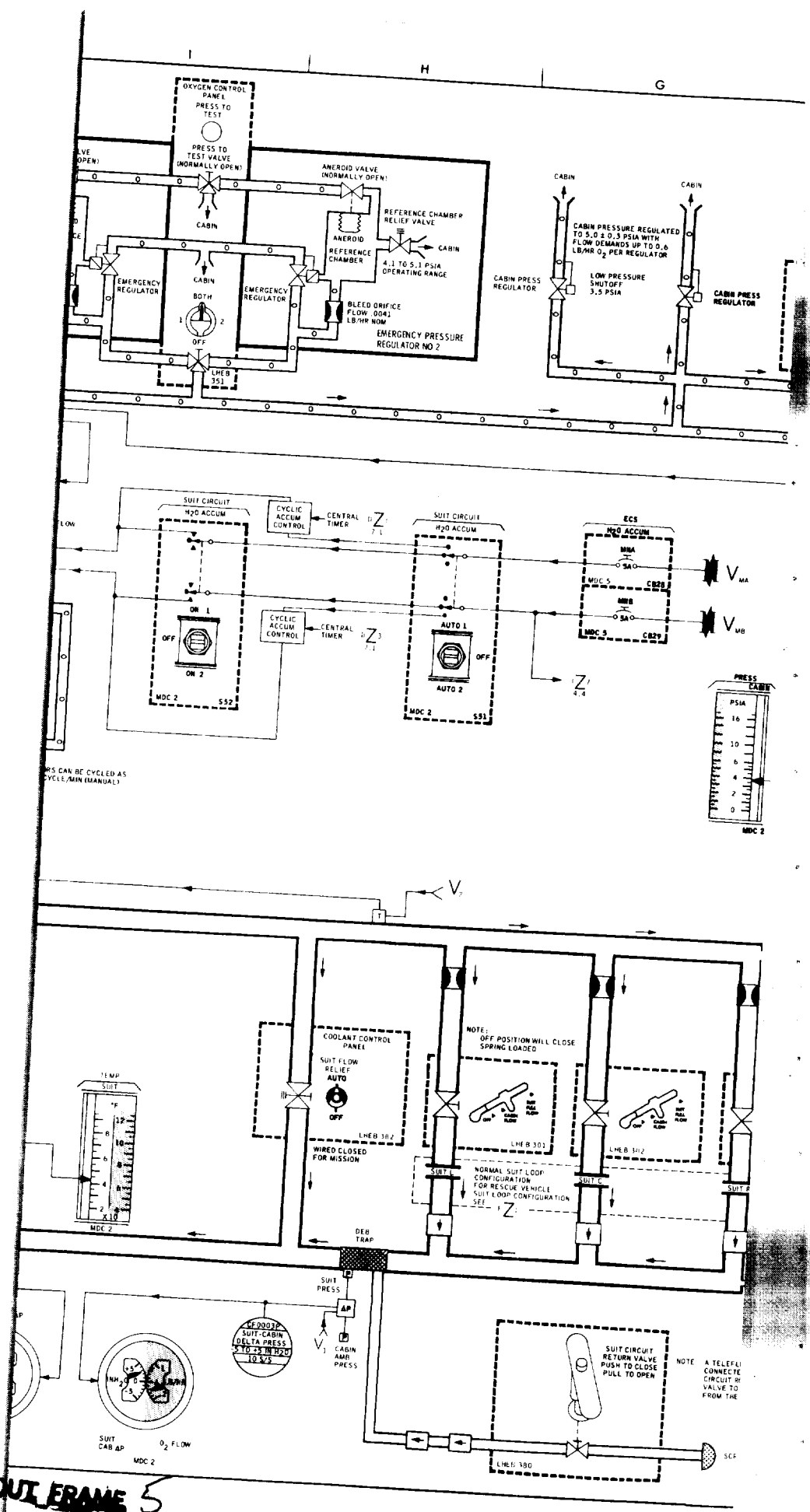

**FOLDOUT FRAME 5**



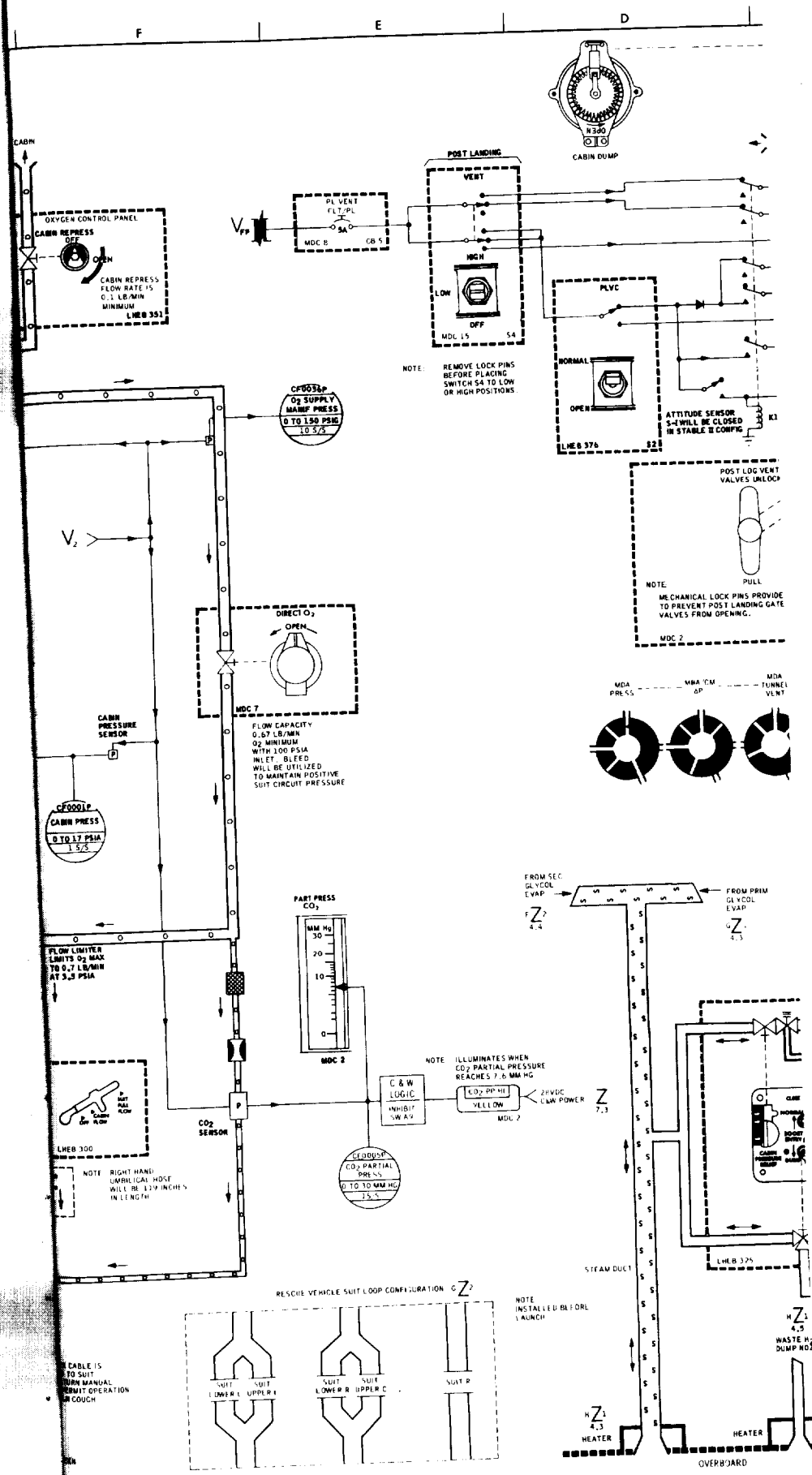

EQLODOUT FRAME 6



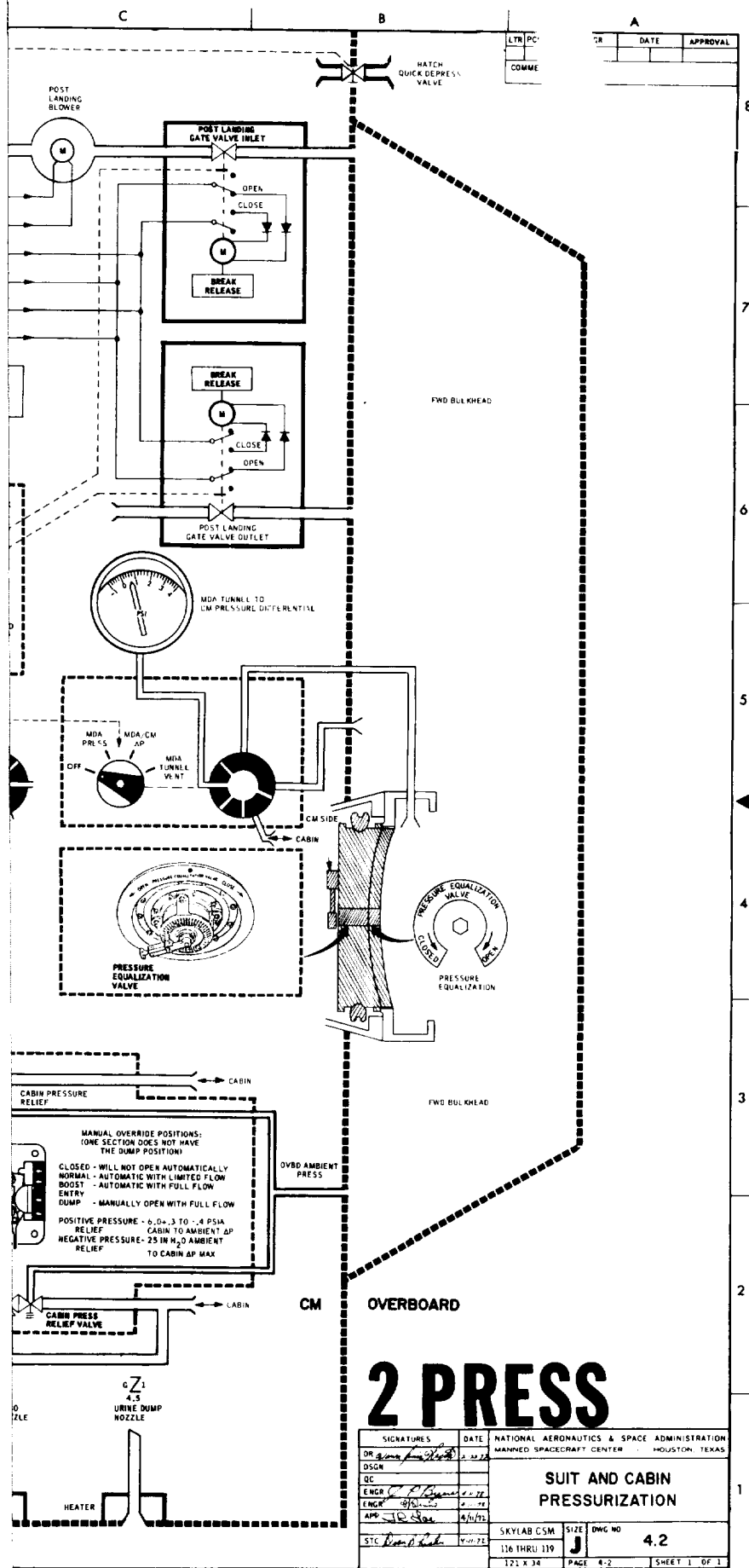

LTR	PC	DATE	APPROVAL
COMME			

MANUAL OVERRIDE POSITIONS:  
(ONE SECTION DOES NOT HAVE THE DUMP POSITION)

CLOSED - WILL NOT OPEN AUTOMATICALLY  
 NORMAL - AUTOMATIC WITH LIMITED FLOW BOOST  
 BOOST - AUTOMATIC WITH FULL FLOW ENTRY  
 DUMP - MANUALLY OPEN WITH FULL FLOW

POSITIVE PRESSURE - 6.0, 3 TO -4 PSIA RELIEF  
 CABIN TO AMBIENT AP  
 NEGATIVE PRESSURE - 25 IN H<sub>2</sub>O AMBIENT RELIEF  
 TO CABIN AP MAX

# 2 PRESS

SIGNATURES		DATE	NATIONAL AERONAUTICS & SPACE ADMINISTRATION MANNED SPACECRAFT CENTER - HOUSTON, TEXAS	
DR	<i>[Signature]</i>	2-22-72		
DSCR				
QC				
ENGR	<i>[Signature]</i>	2-22-72		
ENGR	<i>[Signature]</i>	2-22-72		
APP	<i>[Signature]</i>	2/22/72		
STC	<i>[Signature]</i>	2-22-72		
SKYLAB CSM		SIZE	DWG NO	
116 THRU 119		J	4.2	
121 X 34	PAGE 4-2	SHEET 1 OF 1		

FOLDOUT FRAME 7



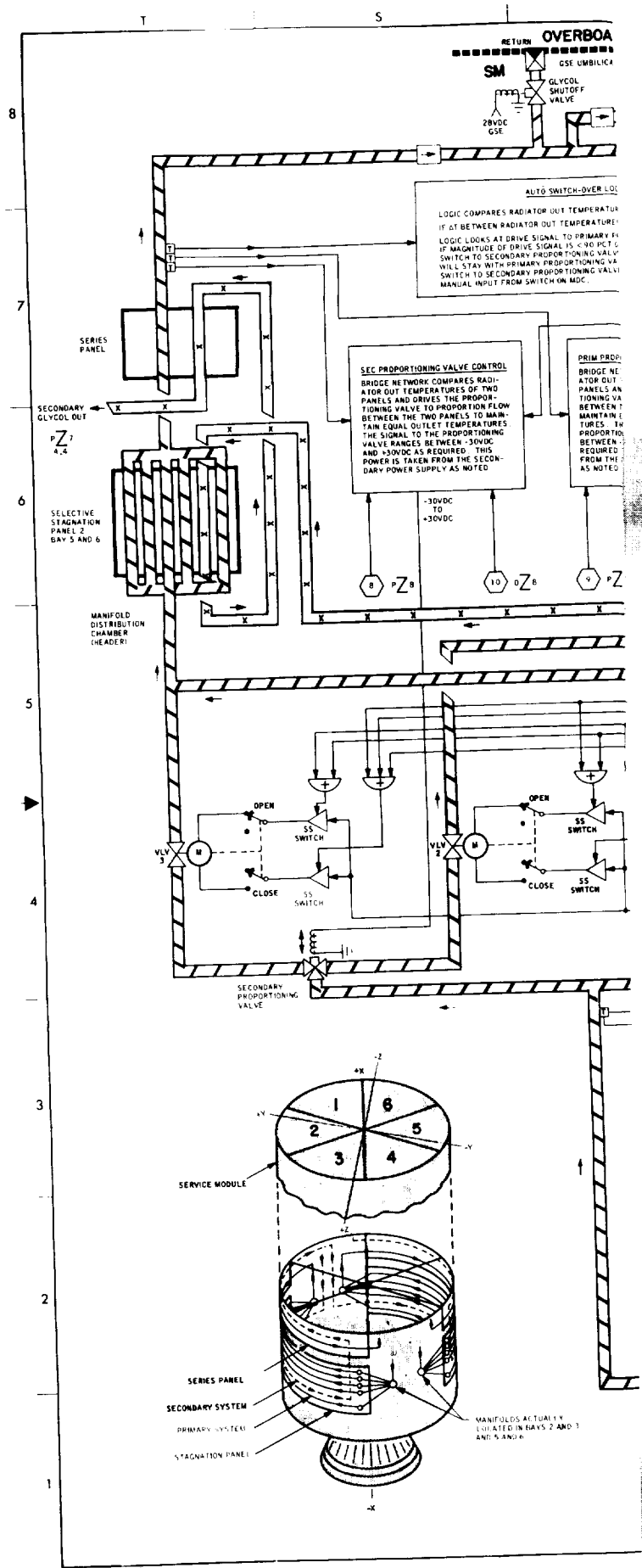

**EOLDOUT FRAME**

1



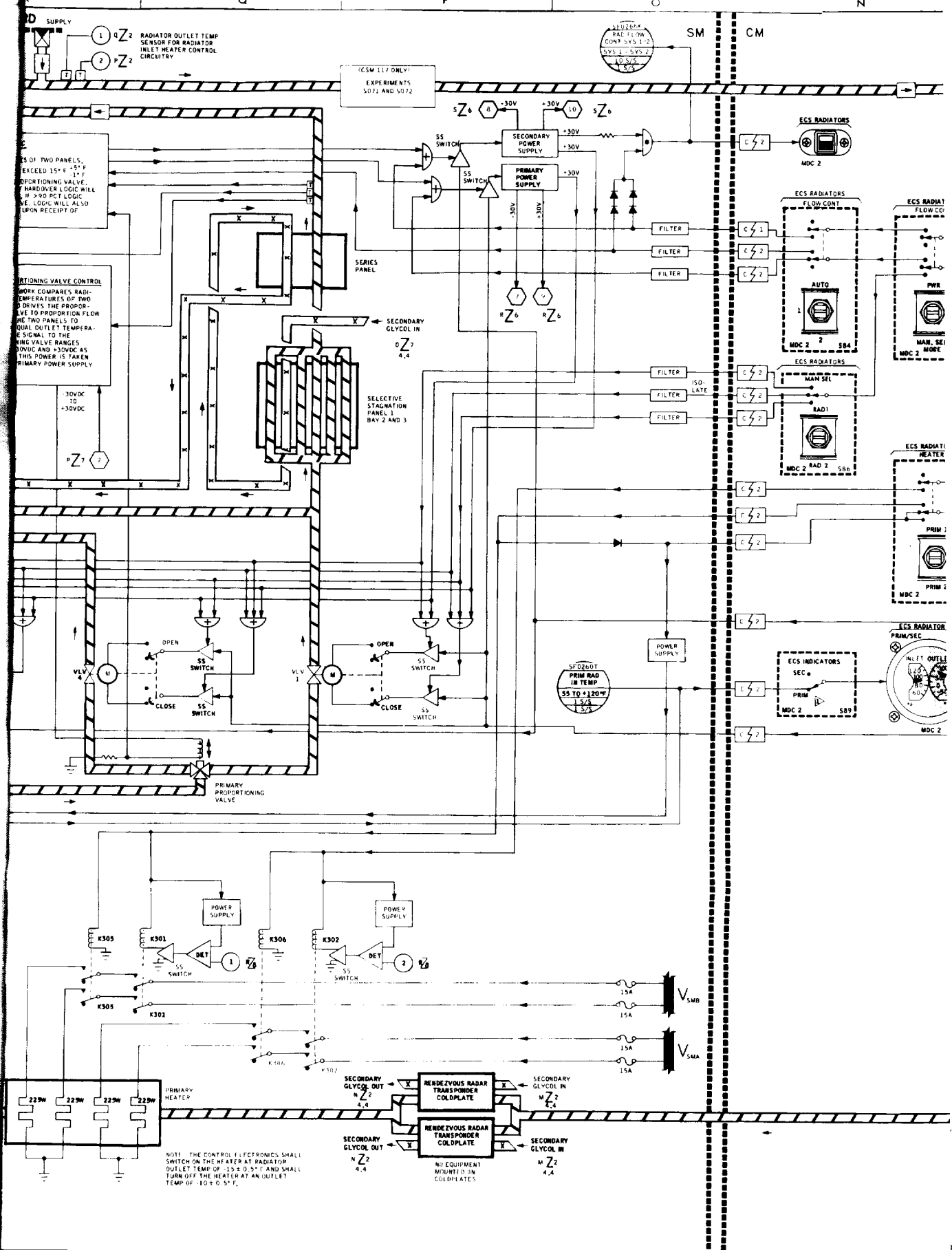

IS OF TWO PANELS, EXCEED 15 ± 0.5°F. OPERATING VALVE HARDOVER LOGIC WILL IN > 90 PCT LOGIC. LOGIC WILL ALSO UPON RECEIPT OF

OPERATING VALVE CONTROL WORK COMPARES RAD-TEMPERATURES OF TWO D DRIVES THE PROPORTIONING VALVE TO PROPORTION FLOW THE TWO PANELS TO EQUAL OUTLET TEMPERATURE SIGNAL TO THE OPERATING VALVE RANGES 0.0VDC AND +30VDC AS THIS POWER IS TAKEN FROM PRIMARY POWER SUPPLY

NOTE: THE CONTROL ELECTRONICS SHALL SWITCH ON THE HEATER AT RADIATOR OUTLET TEMP OF 15 ± 0.5°F AND SHALL TURN OFF THE HEATER AT AN OUTLET TEMP OF 10 ± 0.5°F.

FOLDOUT FRAME 2



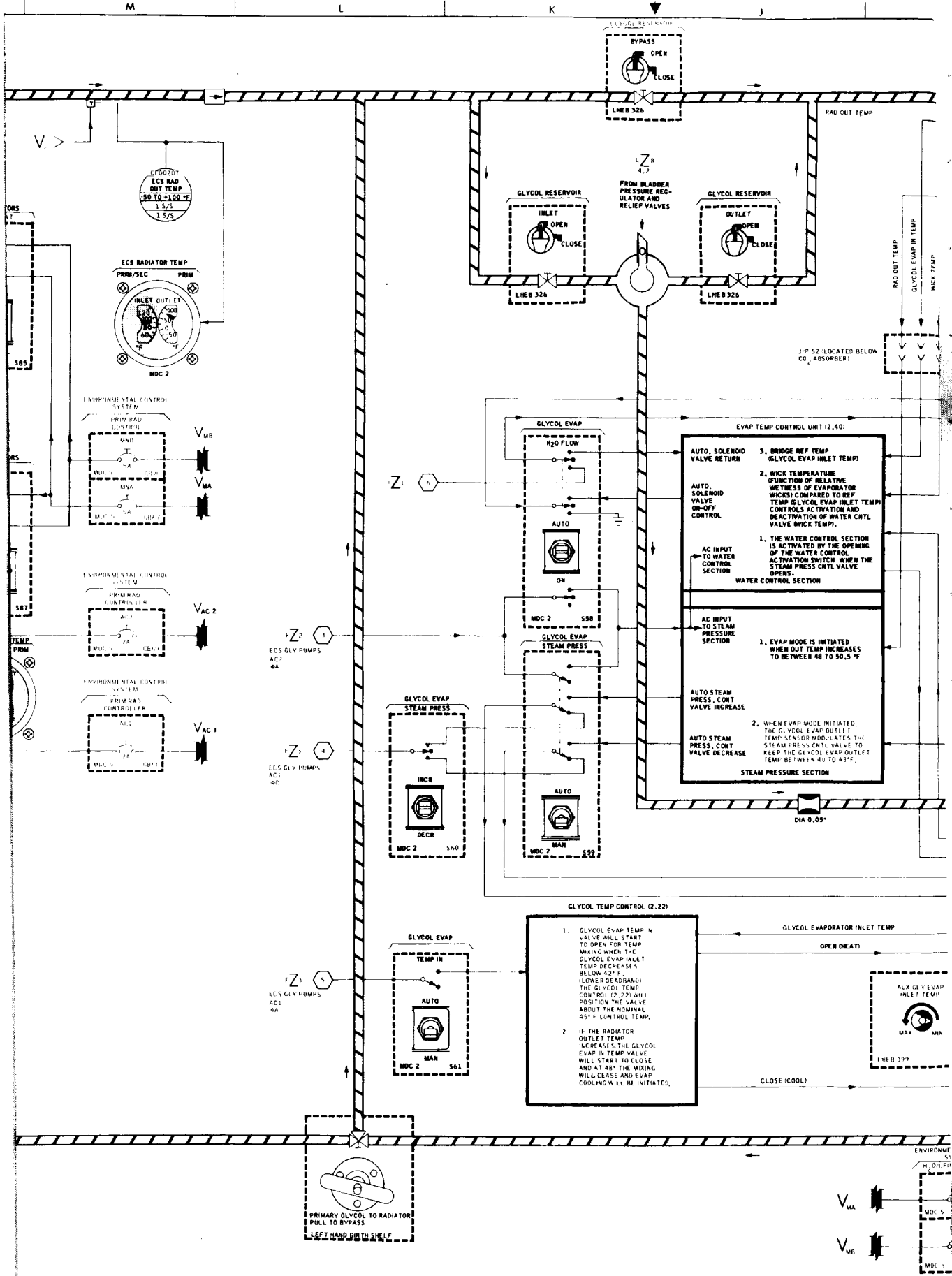

FOLDOUT FRAME 3

*Imaging*

CF0181  
 PRIM EVAP  
 INLET TEMP  
 175 TO 180°  
 1.5/2

NOTE: IN THE EVENT ONE OF THE SENSORS SHOULD FAIL, A REDUNDANT SET CAN BE SELECTED BY RECONNECTING PLUG FROM J52 TO J53. BE SURE POWER IS REMOVED FROM EVAP TEMP CONTROL UNITS 17, 22 AND 2401 ANYTIME PLUG IS REMOVED. SET GLYCOL EVAP W20 FLOW SWITCH, 558 MDC 2, TO OFF (CENTER). GLYCOL EVAP STEAM PRESS SWITCH, 559 MDC 2, TO MAN. AND GLYCOL EVAP TEMP IN SWITCH 5A3 MDC 2 TO MAN.

JIP 53 (LOCATED BELOW CO<sub>2</sub> ABSORBER)

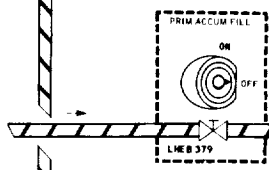
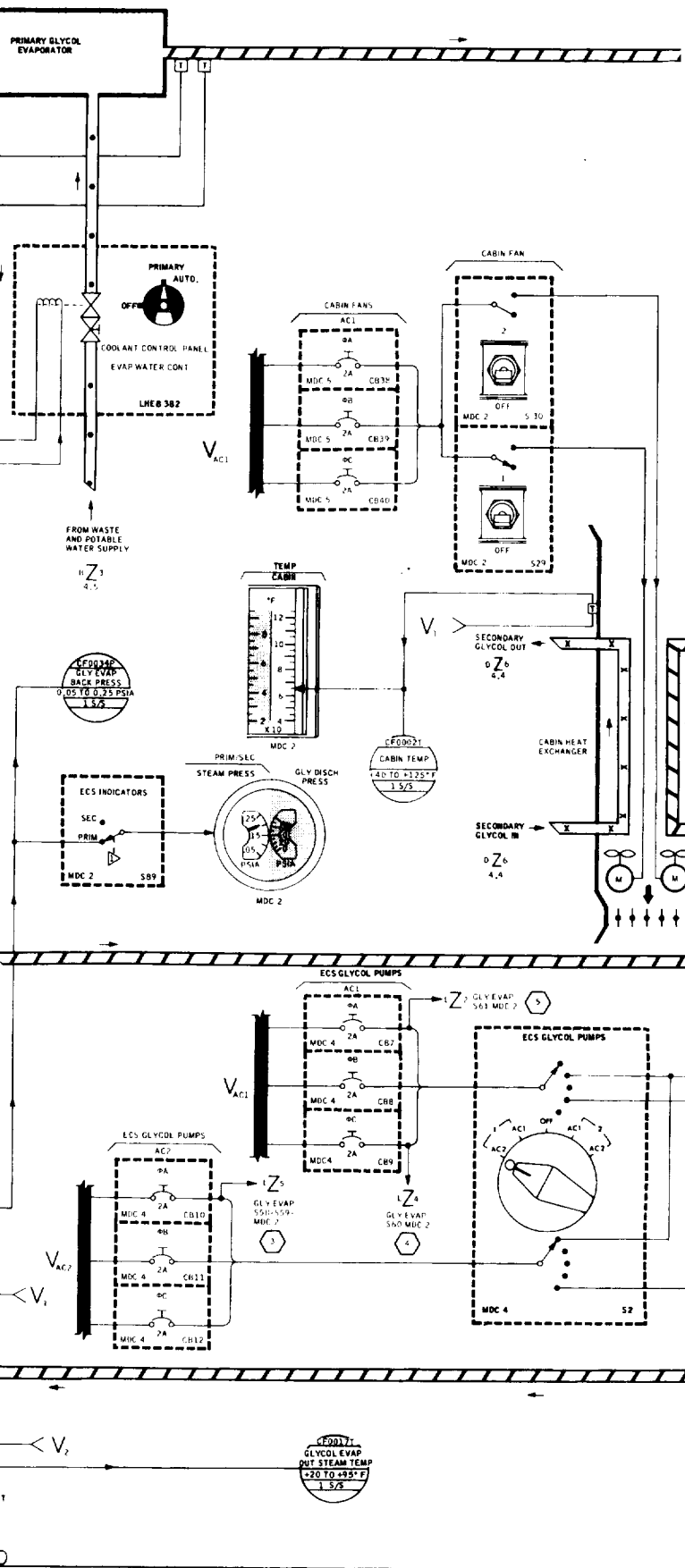

WATER CONTROL ACTIVATION SWITCH OPENS WHEN STEAM PRESSURE CONTROL VALVE OPENS TO ALLOW OPERATION OF THE WATER CONTROL SECTION. SWITCH CLOSURES WHEN STEAM PRESSURE CONTROL VALVE CLOSURES TO PREVENT WATER CONTROL SECTION OPERATION.

MOTOR TAKES APPROX 50 SEC FROM FULL OPEN TO FULL CLOSE.

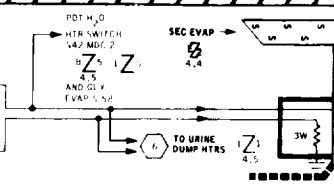
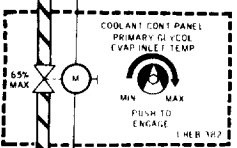

FOLDOUT FRAME 4



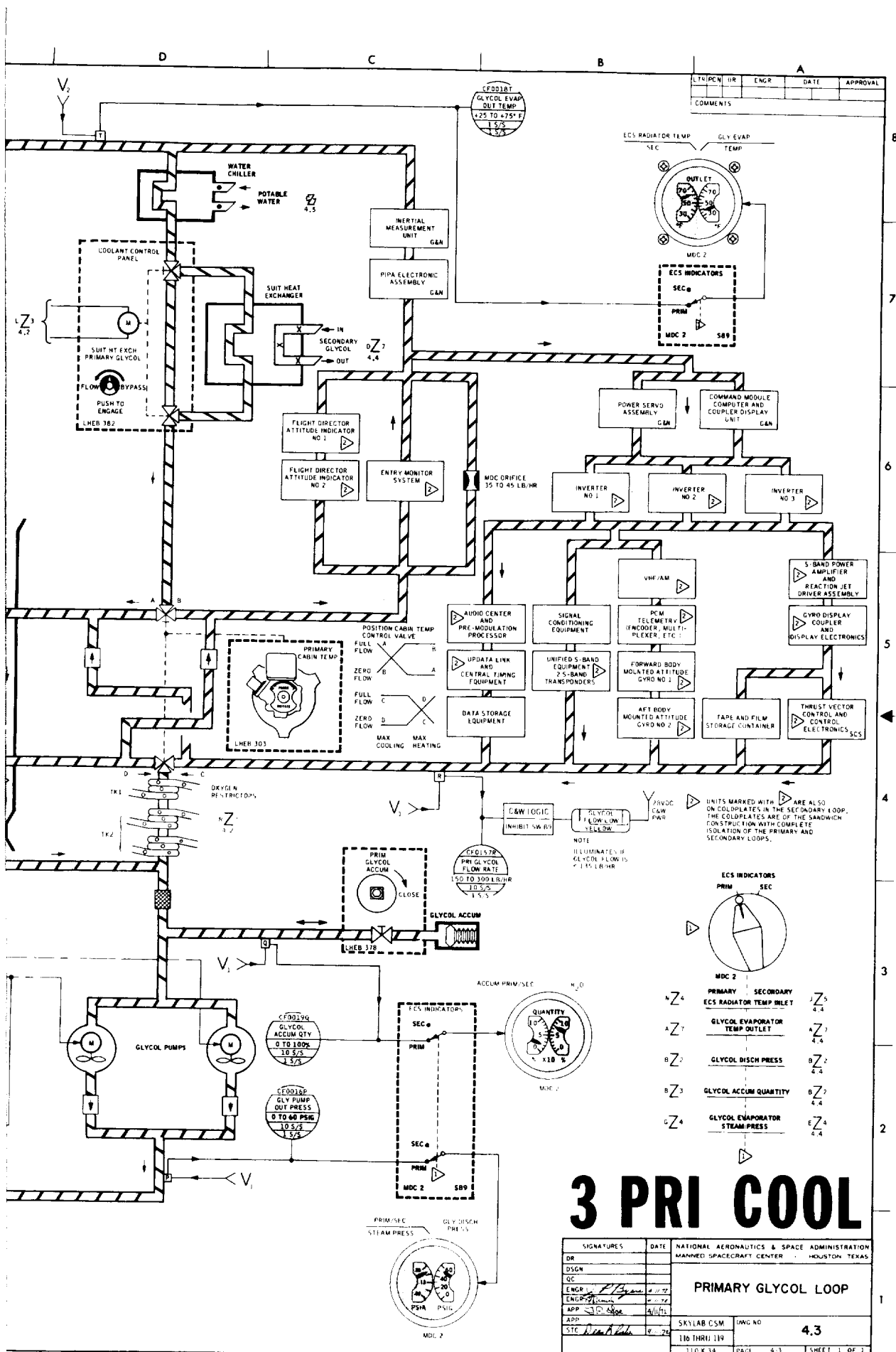

LT	PCN	HR	ENGR	DATE	APPROVAL

COMMENTS

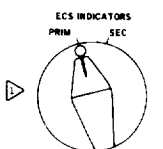

- PRIM 2
- SEC 2
- PRIM 4
- SEC 4
- PRIM 7
- SEC 7
- PRIM 2
- SEC 2
- PRIM 3
- SEC 3
- PRIM 4
- SEC 4

# 3 PRI COOL

SIGNATURES	DATE	NATIONAL AERONAUTICS & SPACE ADMINISTRATION MANNED SPACECRAFT CENTER - HOUSTON, TEXAS	
DR			
DSEN			
QC			
ENGR			
ENGR			
APP			
APP			
STC		SKYLAB CSM	HWG NO
		116 THRU 119	4.3
		310 K 34	PAGE 4.3 SHEET 1 OF 3

FOLDOUT FRAME 5





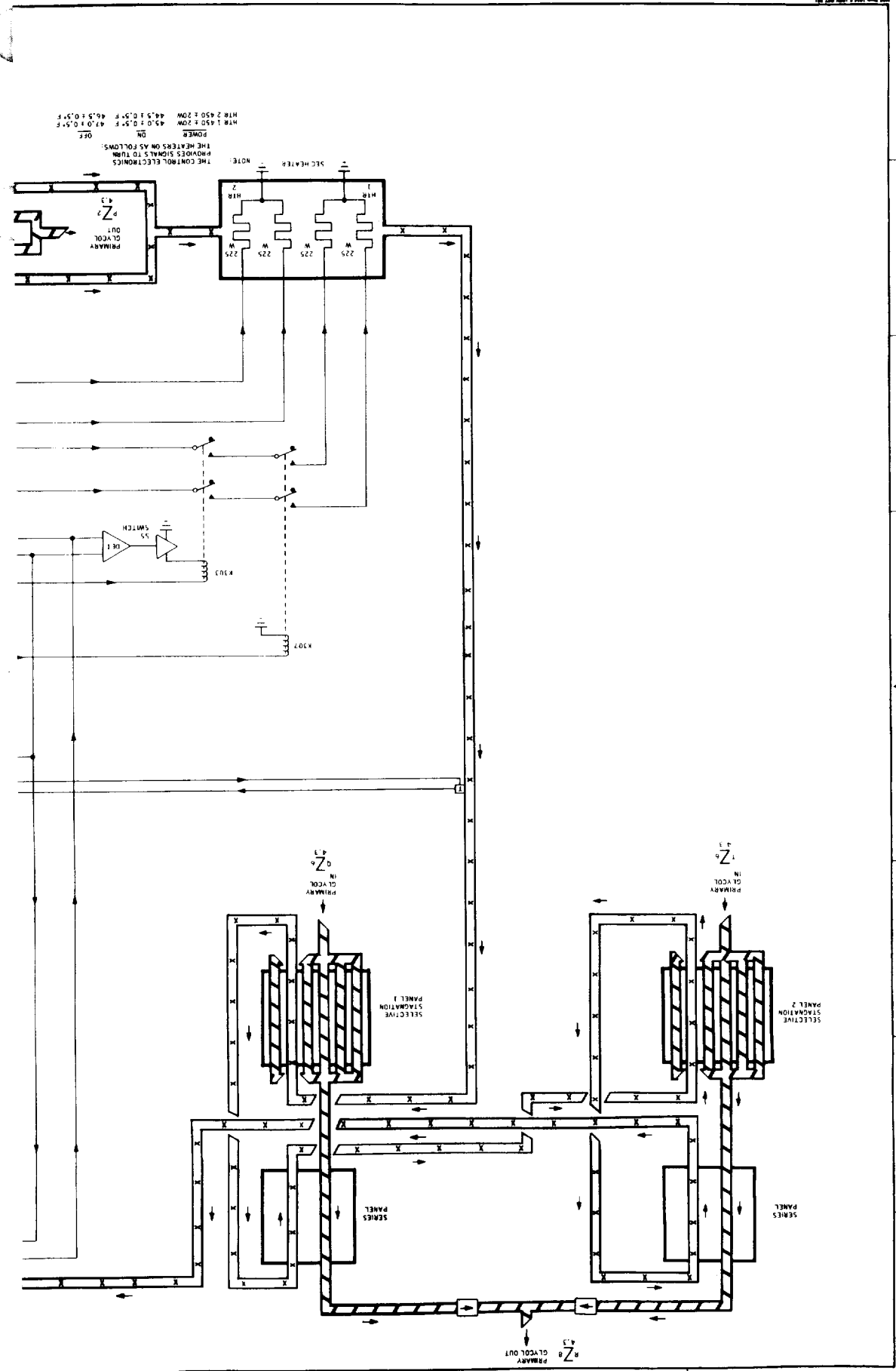

HIR 2450 F 20W 44.5 F 0.5 F 46.5 F 0.5 F  
 HIR 1450 F 20W 43.0 F 0.5 F 47.0 F 0.5 F  
 HIR 2450 F 20W 44.5 F 0.5 F 46.5 F 0.5 F  
 POWER ON  
 OFF  
 THE CONTROL ELECTRONICS  
 PROVIDES SIGNALS TO TURN  
 THE HEATERS ON AS FOLLOWS:

NOTE

FOLDOUT FRAME

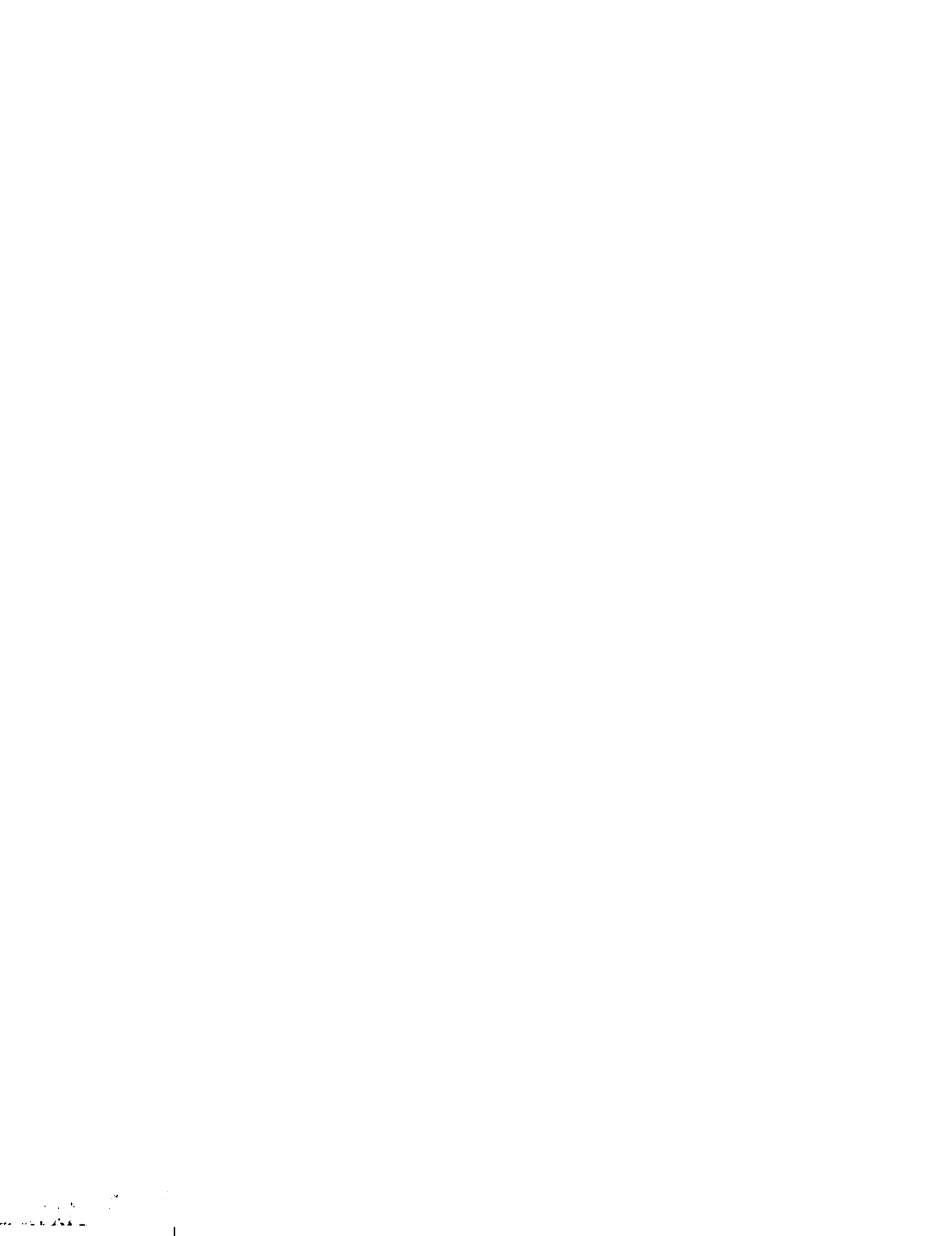

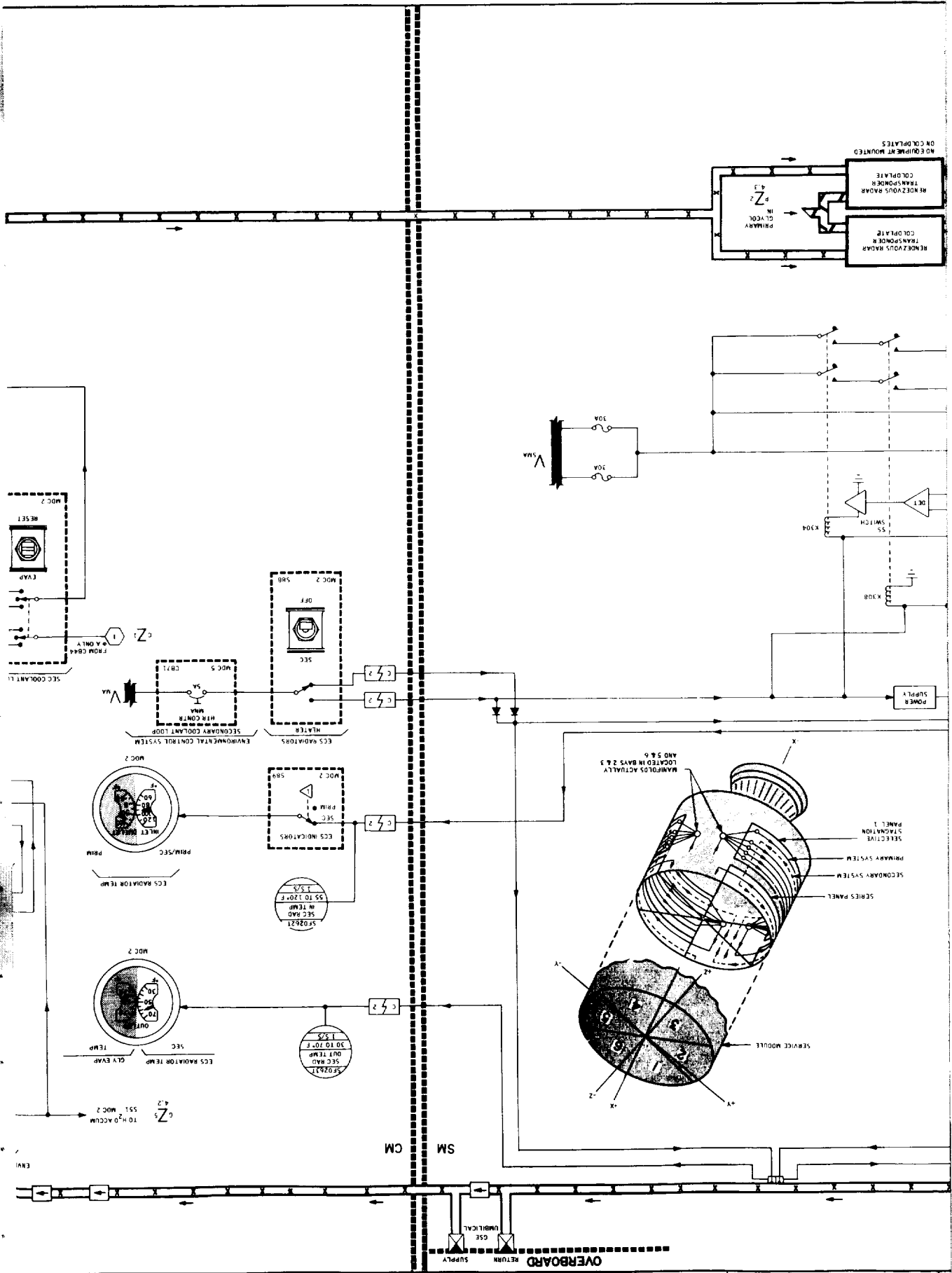

FOLDOUT FRAME 2

1000

1000

1

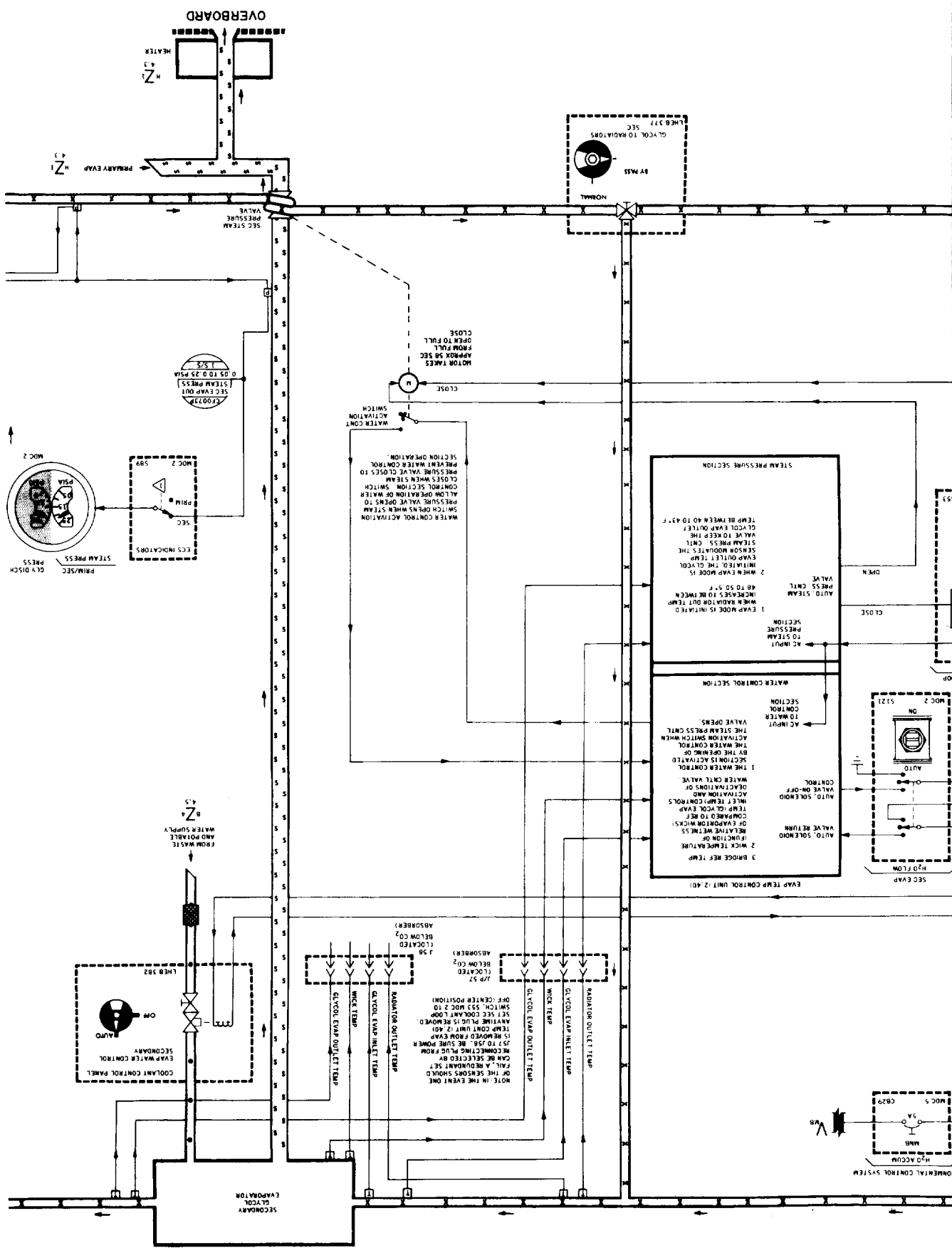

OVERBOARD

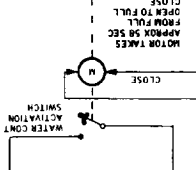
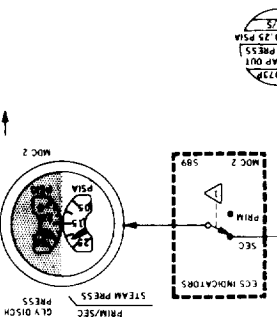
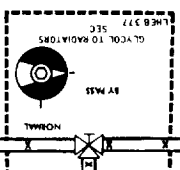
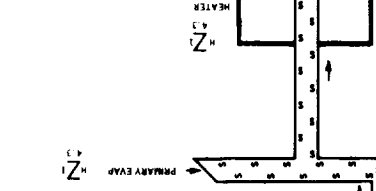

WATER CONTROL ACTIVATION SWITCH  
 SWITCH OPENS WHEN STEAM PRESSURE VALVE OPENS TO ALLOW OPERATION OF WATER CONTROL SECTION.  
 CLOSURE WHEN STEAM PRESSURE VALVE CLOSURE TO PREVENT WATER CONTROL SECTION OPERATION.

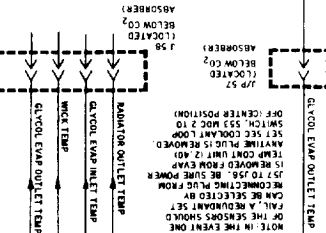
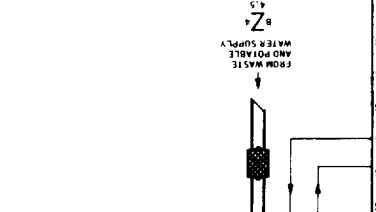
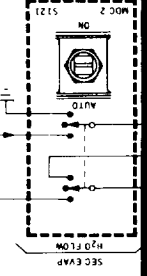
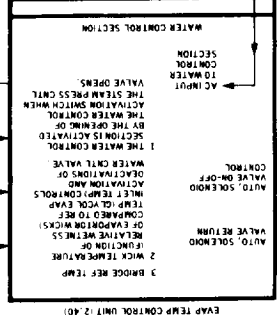
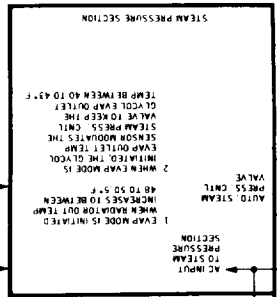

NOTE: IN THE EVENT ONE OR THE OTHERS SHOULD FAIL, REDUNDANT SET POINTS SHOULD BE USED TO DETERMINE IF THE SURE POWER IS REMOVED FROM EVAPORATOR. THE SURE POWER CAN BE SELECTED BY ANNOTATING THE ROOM NUMBER IN THE POSITION OF (CENTER POSITION) 537 SEC COOLANT FLOW. MONITORING PLUG IS REMOVED. 537 SEC COOLANT FLOW MONITOR OUTLET TEMP. RADIATOR OUTLET TEMP. GLYCOL EVAP INLET TEMP. GLYCOL EVAP OUTLET TEMP.

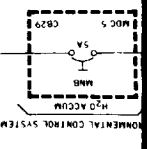

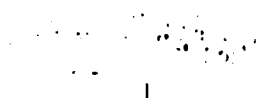

DATE	DESIGNER	APP. NO.	SIZE	SCALE	SHEET
11/18/72	J. J. ...	118 THRU 119	44	4-4	1 OF 1

**SECONDARY GLYCOL LOOP**

NATIONAL AERONAUTICS & SPACE ADMINISTRATION  
 MANAGED PROMOBILITY CENTER - HONOLULU, HAWAII

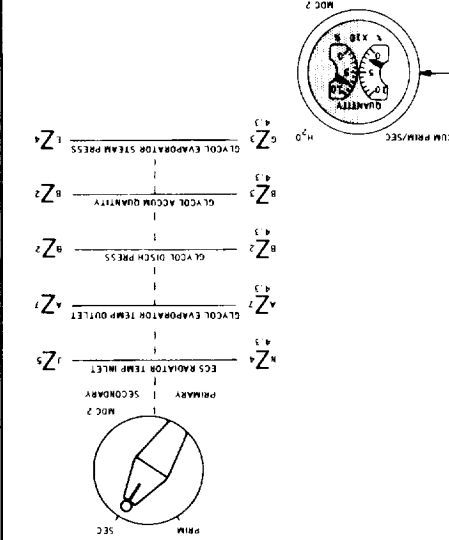

**NOTES**

1. ALL UNITS SHOWN ON SECONDARY GLYCOL LOOP.

2. DRAWING 4-3 FOR PRIMARY GLYCOL LOOP, SEE ECS OF THE PRIMARY AND SECONDARY THERM COMPENSATE ISOLATION OF THE SAMPLING LINE RELATION COLLECTORS ARE ALSO ON PRIMARY COLLECTORS.

3. ECS INDICATORS

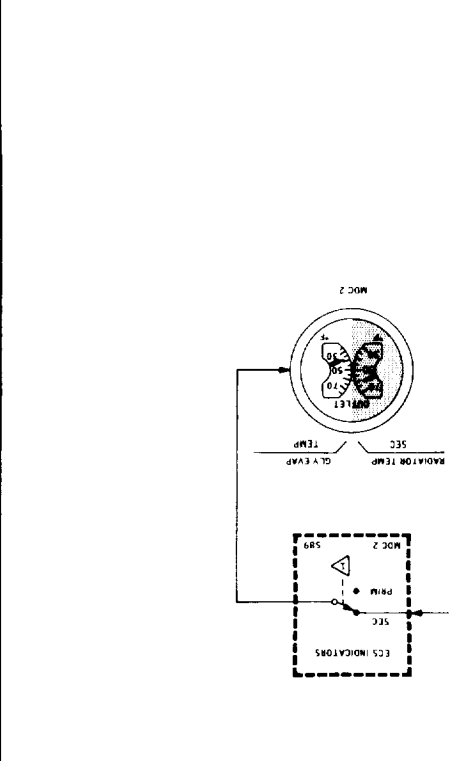

DATE	DESIGNER	APP. NO.	SIZE	SCALE	SHEET
11/18/72	J. J. ...	118 THRU 119	44	4-4	1 OF 1

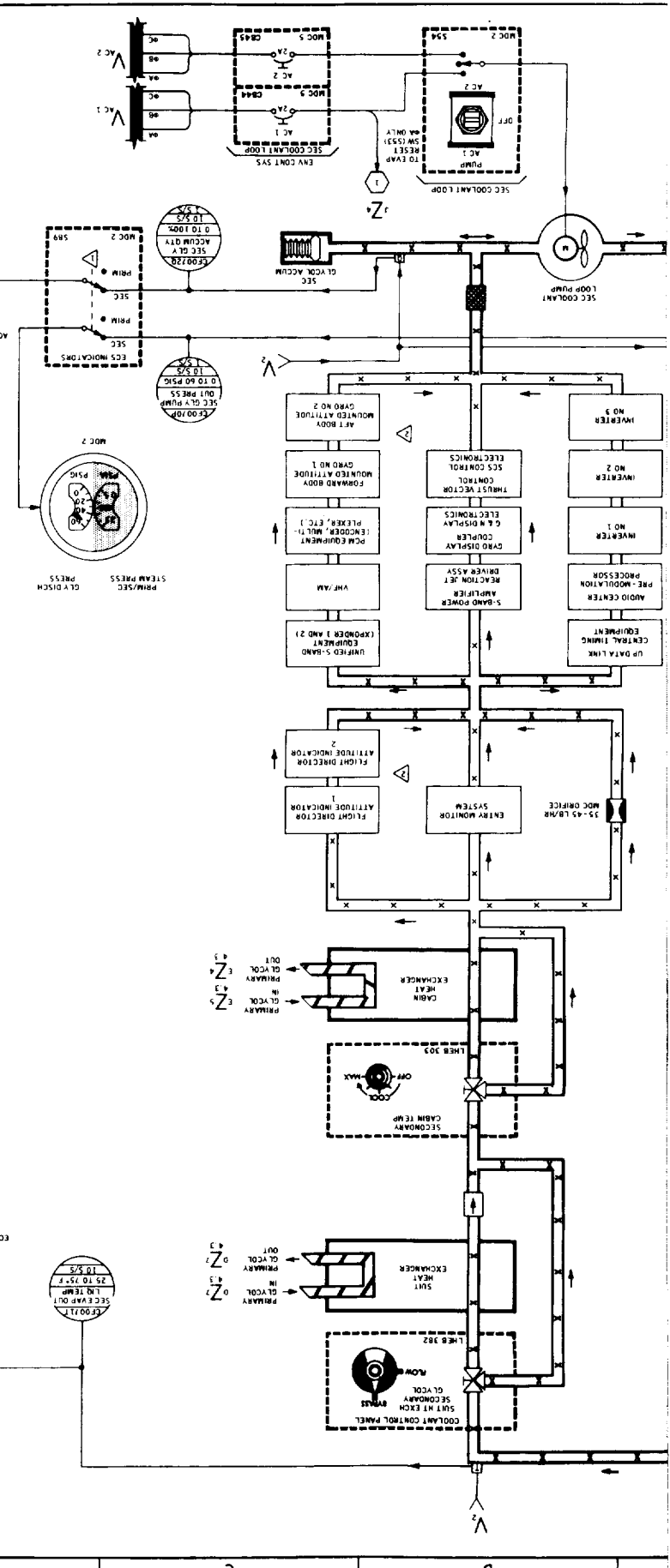

**FOLDOUT FRAME 4**

1000



8

7

6

5

4

3

2

1

**FOLDOUT FRAME**



H<sub>2</sub>O FROM FUEL CELLS  
AT APPROX 61.5 PSIG

GZ  
4.7

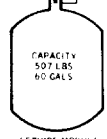
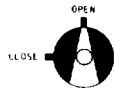

CS 1

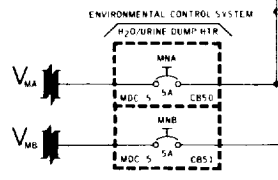
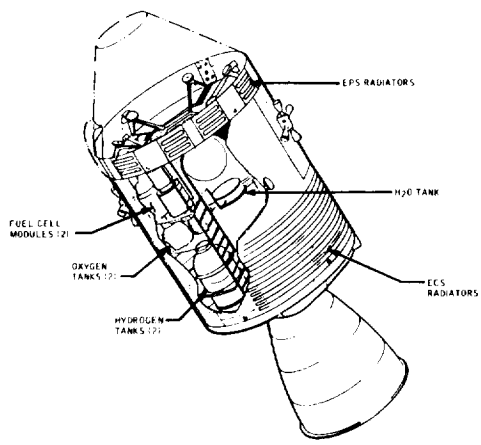
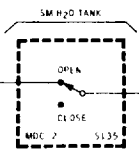



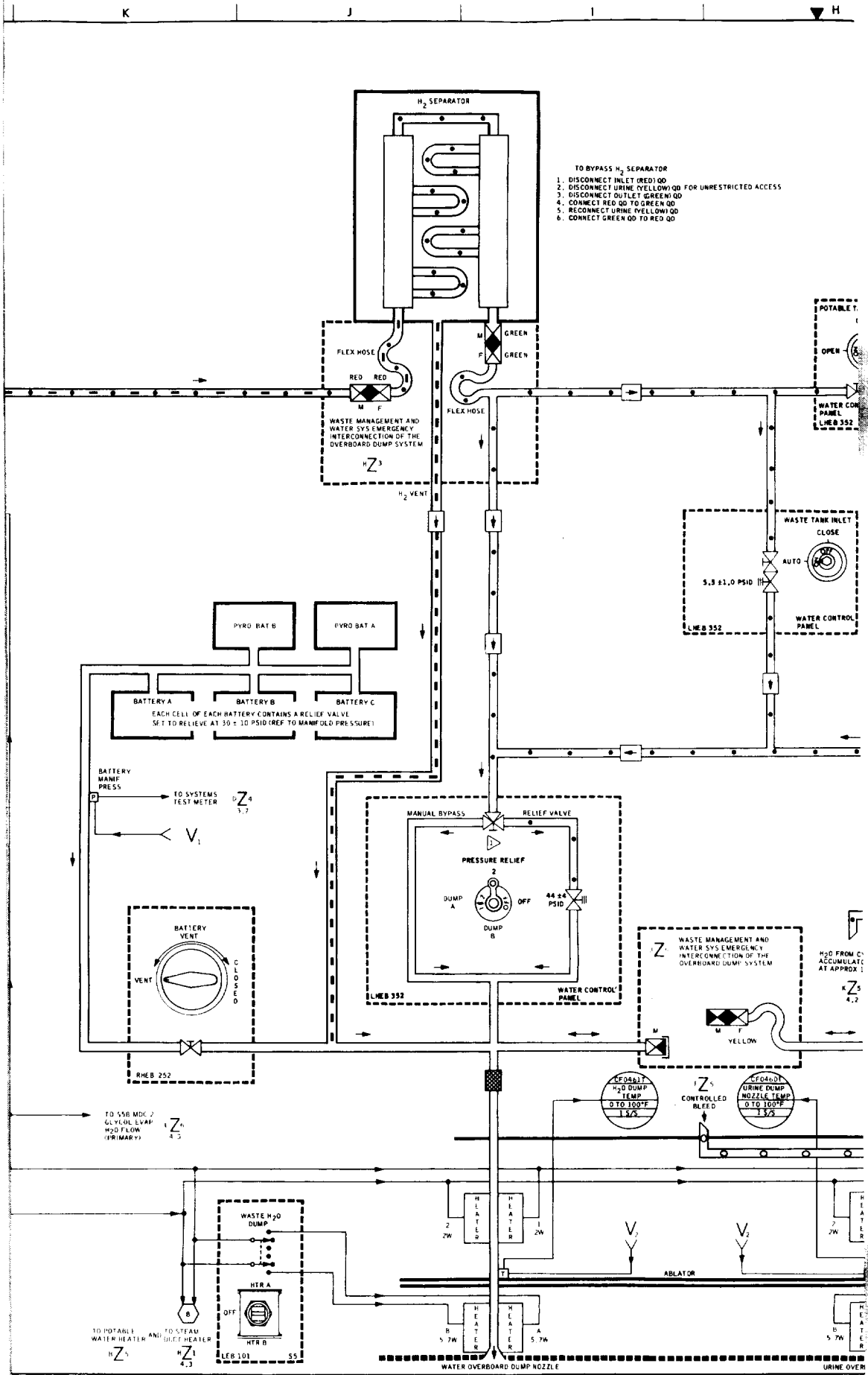

FOLDOUT FRAME 3



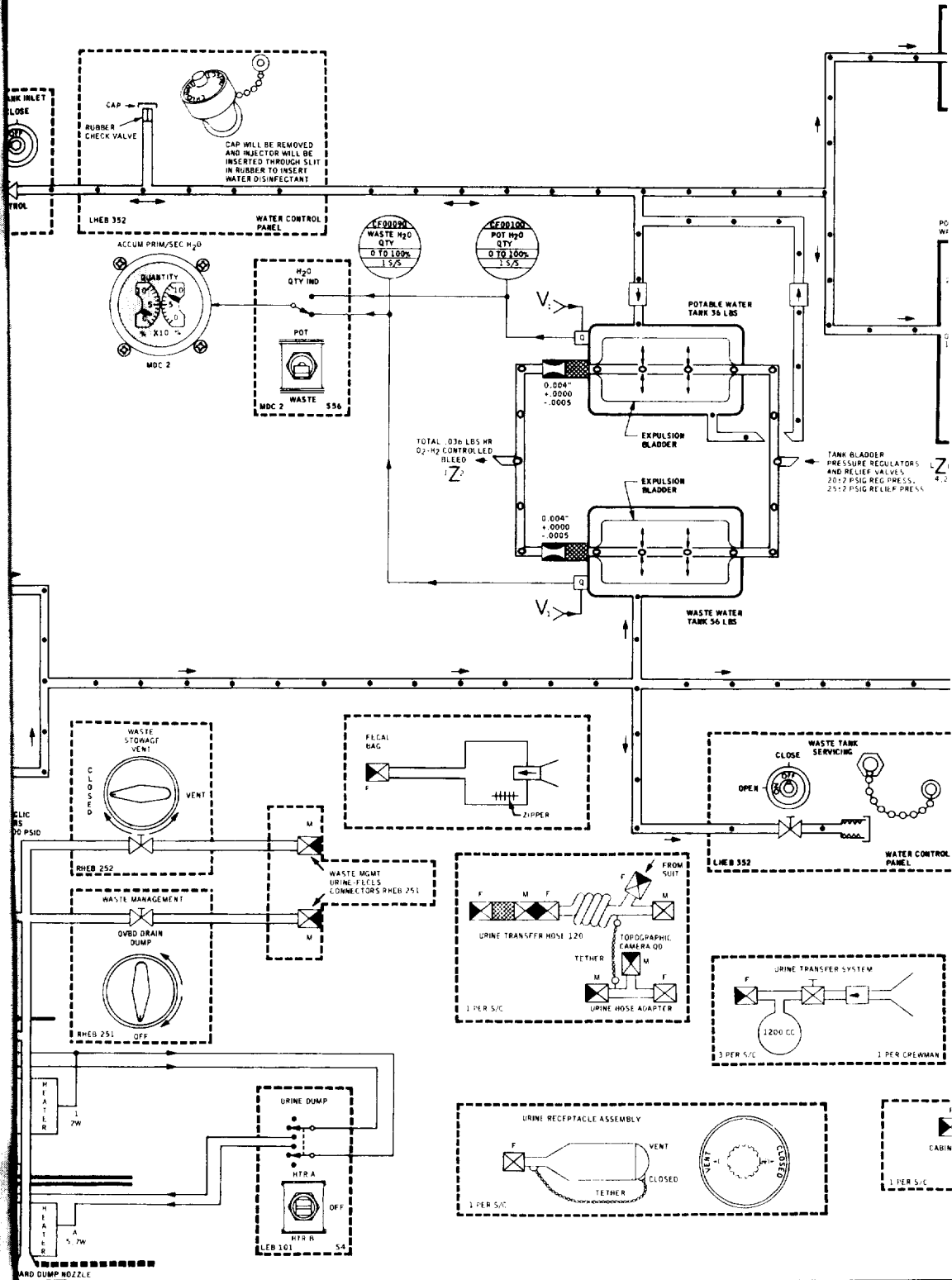





D		C		B		A	
LTR	PCN	DR	ENGR	DATE	APPROVAL	COMMENTS	

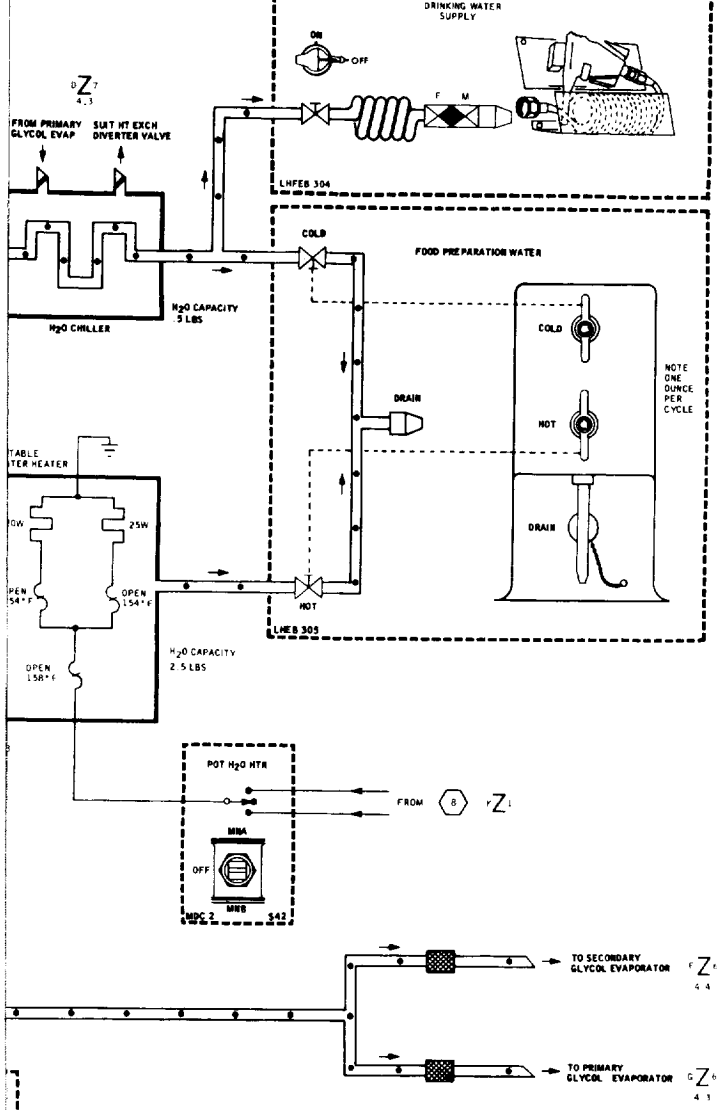

8
7
6
5
4
3
2
1

▽ PRESSURE RELIEF VALVE BUMP MODES  
 POSITION                      FUNCTION  
 OFF                              NO FLOW  
 2                                  FLOW THRU RELIEF VALVE ONLY  
 A                                  FLOW THRU RELIEF VALVE AND MANUAL BYPASS  
 B                                  FLOW THRU MANUAL BYPASS ONLY

# 5 WATER

SIGNATURES		DATE		NATIONAL AERONAUTICS & SPACE ADMINISTRATION MANNED SPACECRAFT CENTER HOUSTON, TEXAS	
DR				<b>WATER AND WASTE MANAGEMENT</b>	
DSGX					
QC					
ENGR	<i>[Signature]</i>				
APP	<i>[Signature]</i>				
CSM		DWG NO	4.5		
116 THRU 119		PAGE	4-5	SHEET 1 OF 1	

FOLDOUT FRAME 5



5 FUEL CELL/  
CRYOGENICS  
SYSTEM

)

)

)

)

)

|

6 COMMUNI-  
CATIONS  
SYSTEM

)

)

)

)

)

2000

|

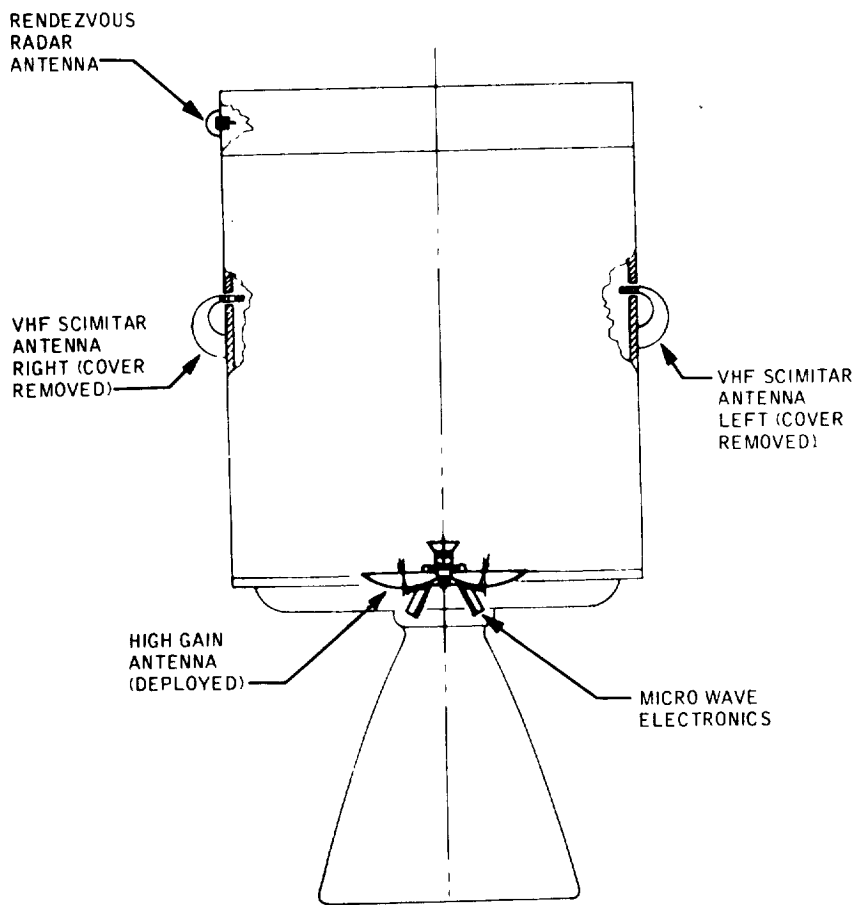
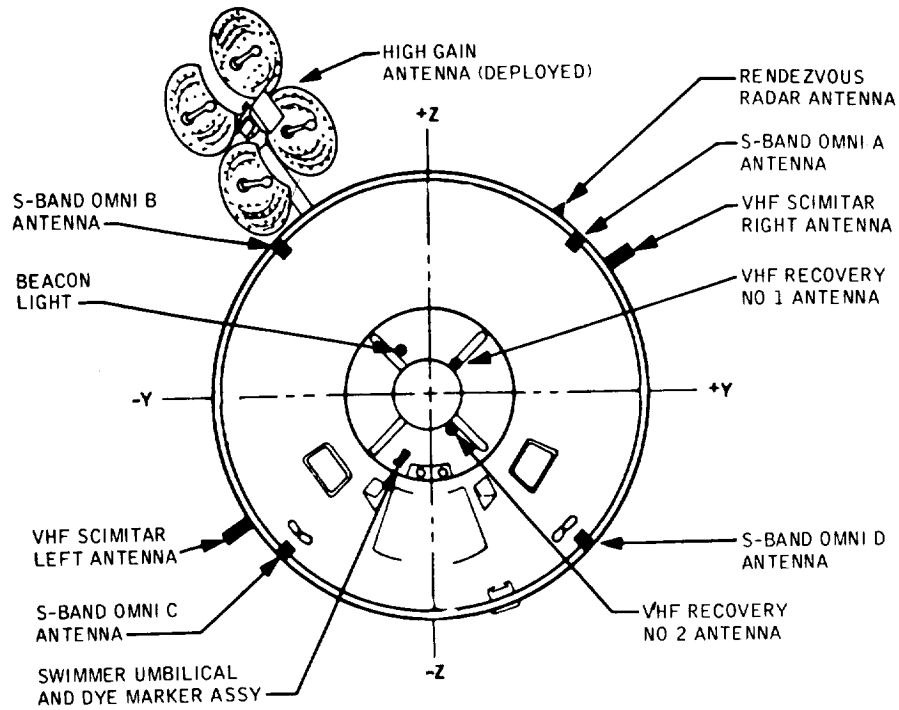

APRON ITEM 6.1

**EOLDOUT FRAME**

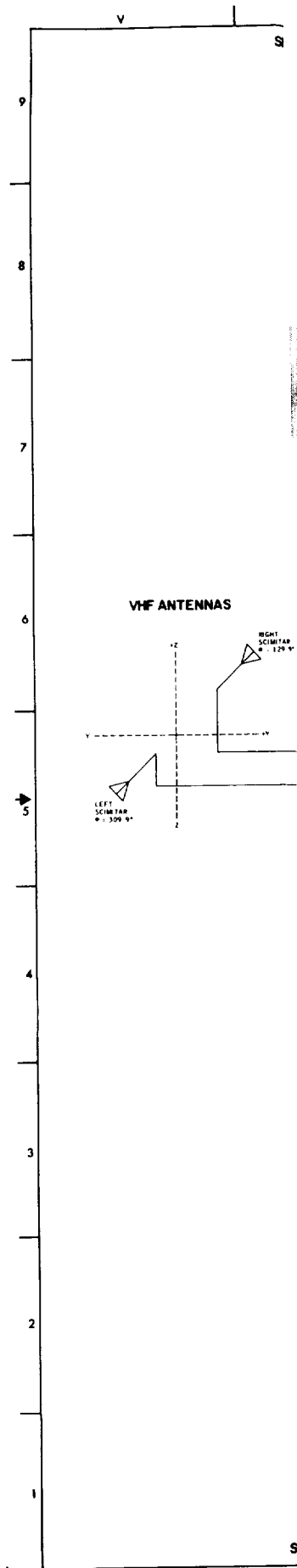





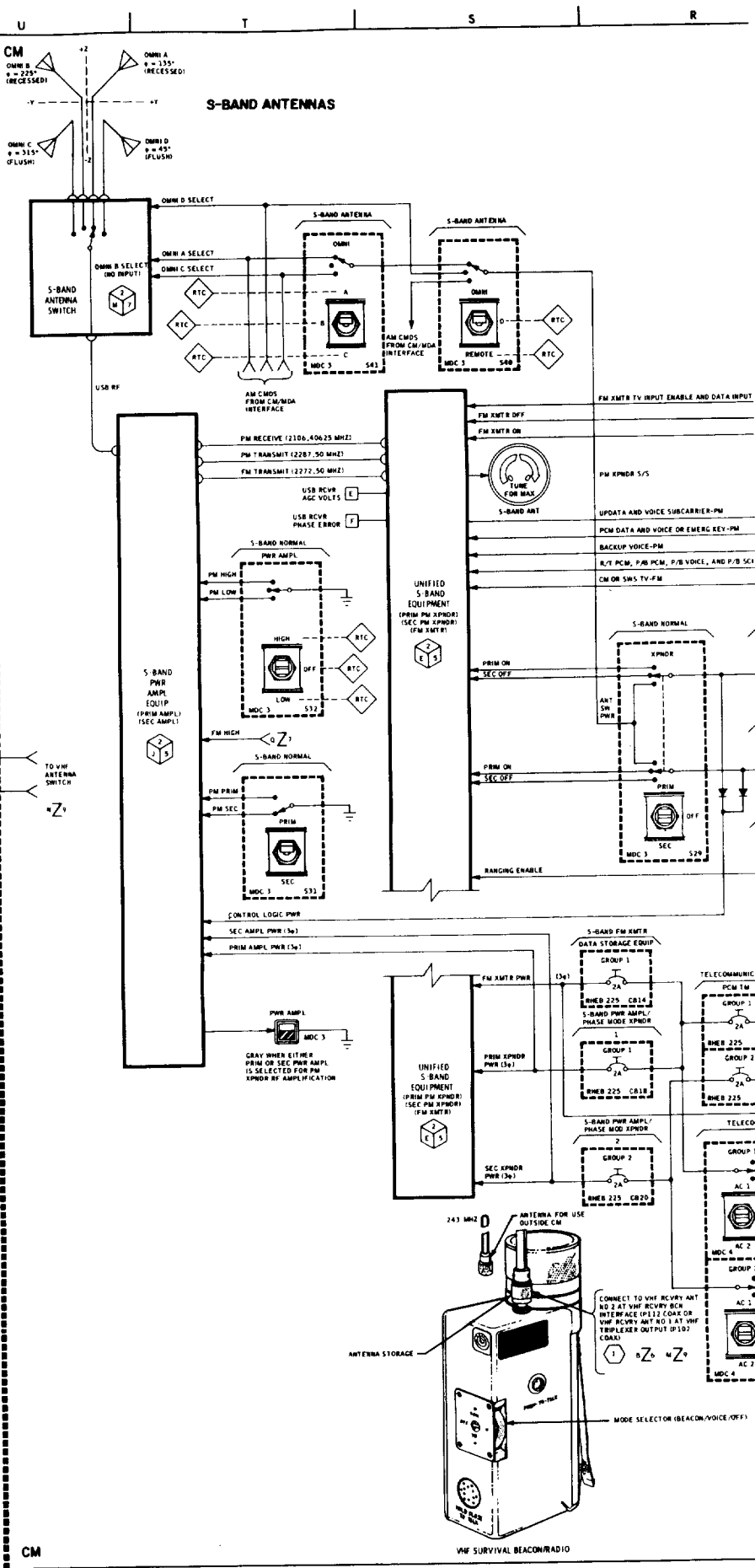



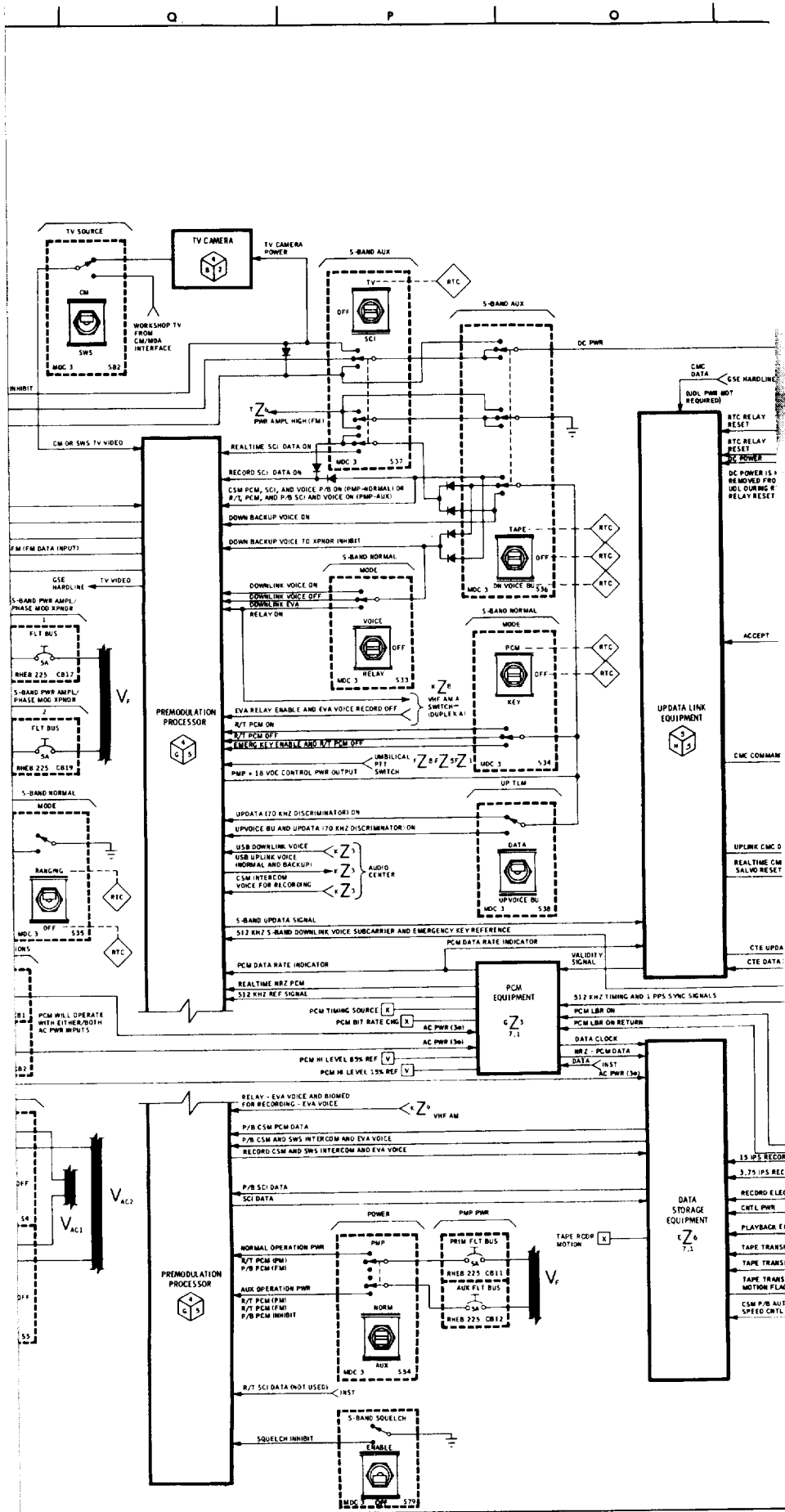



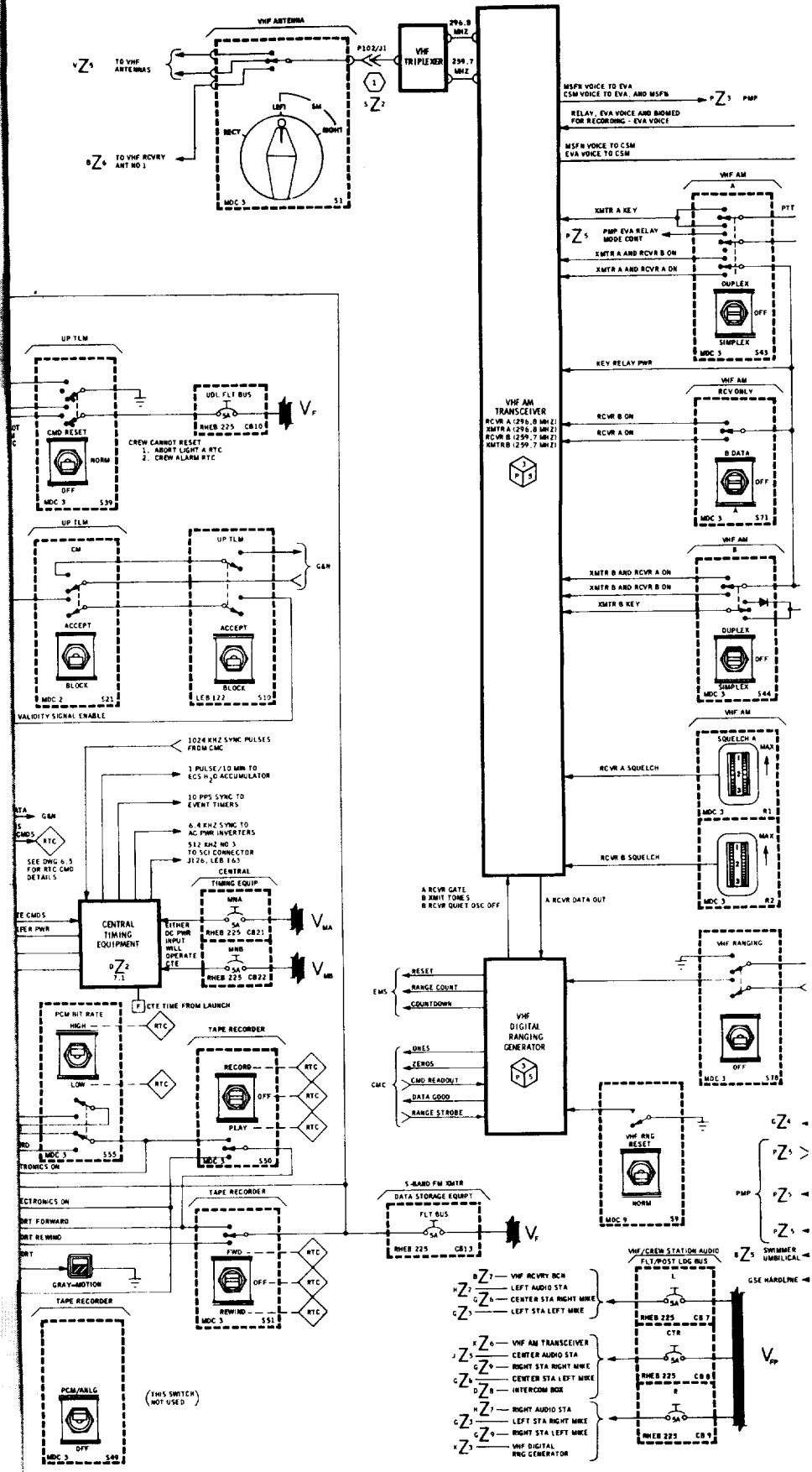



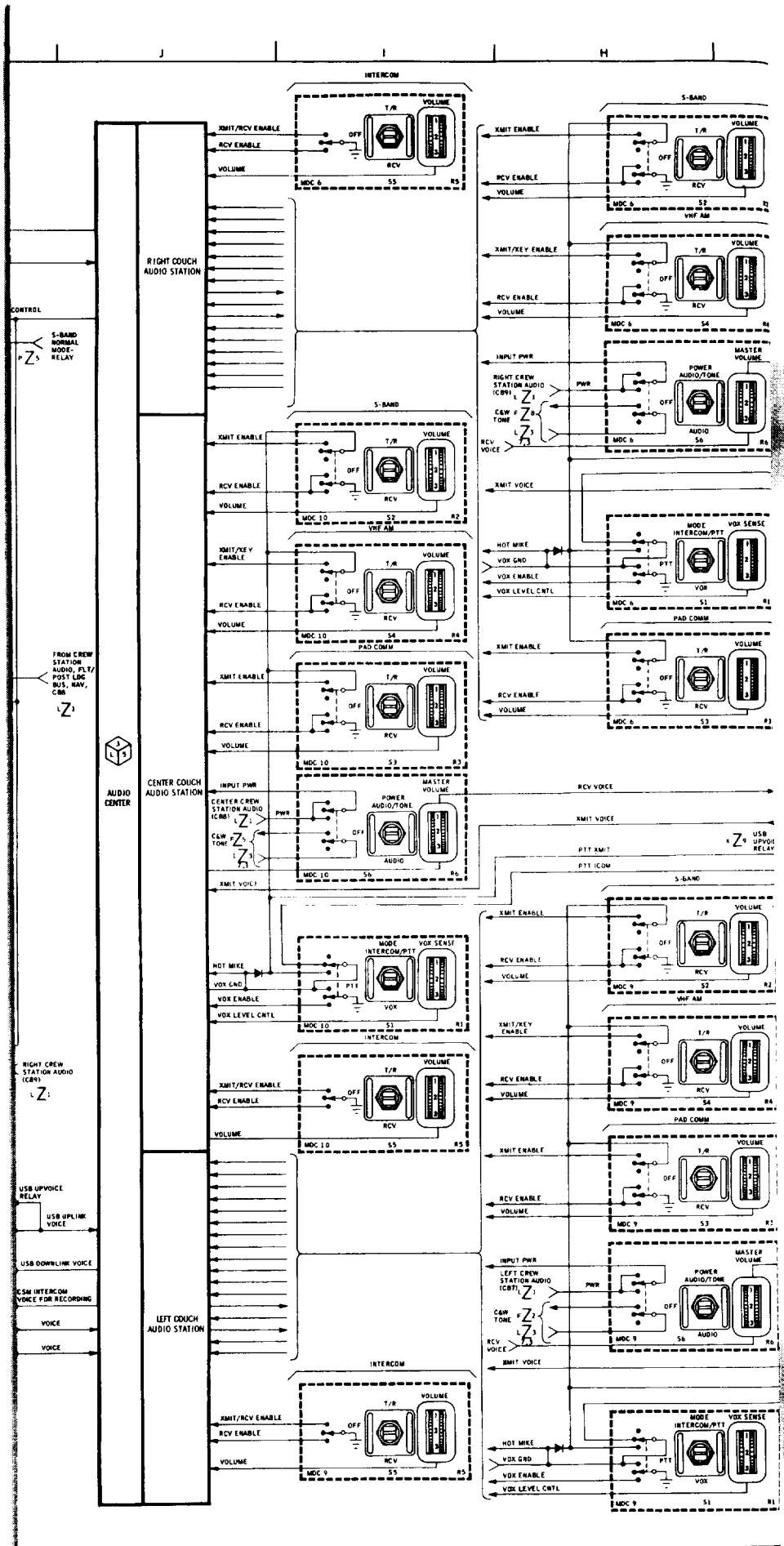





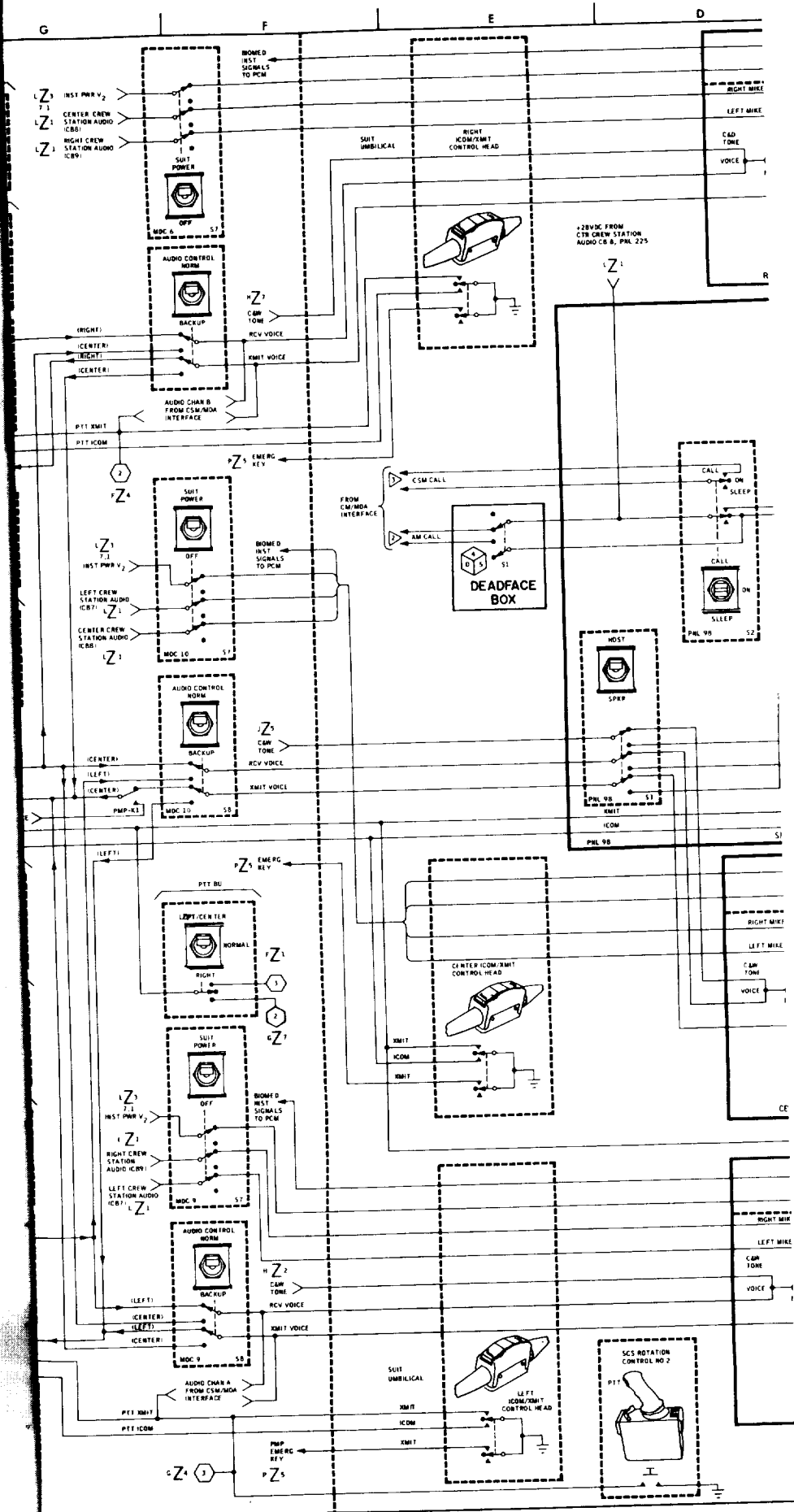

FOLDOUT FRAME 6



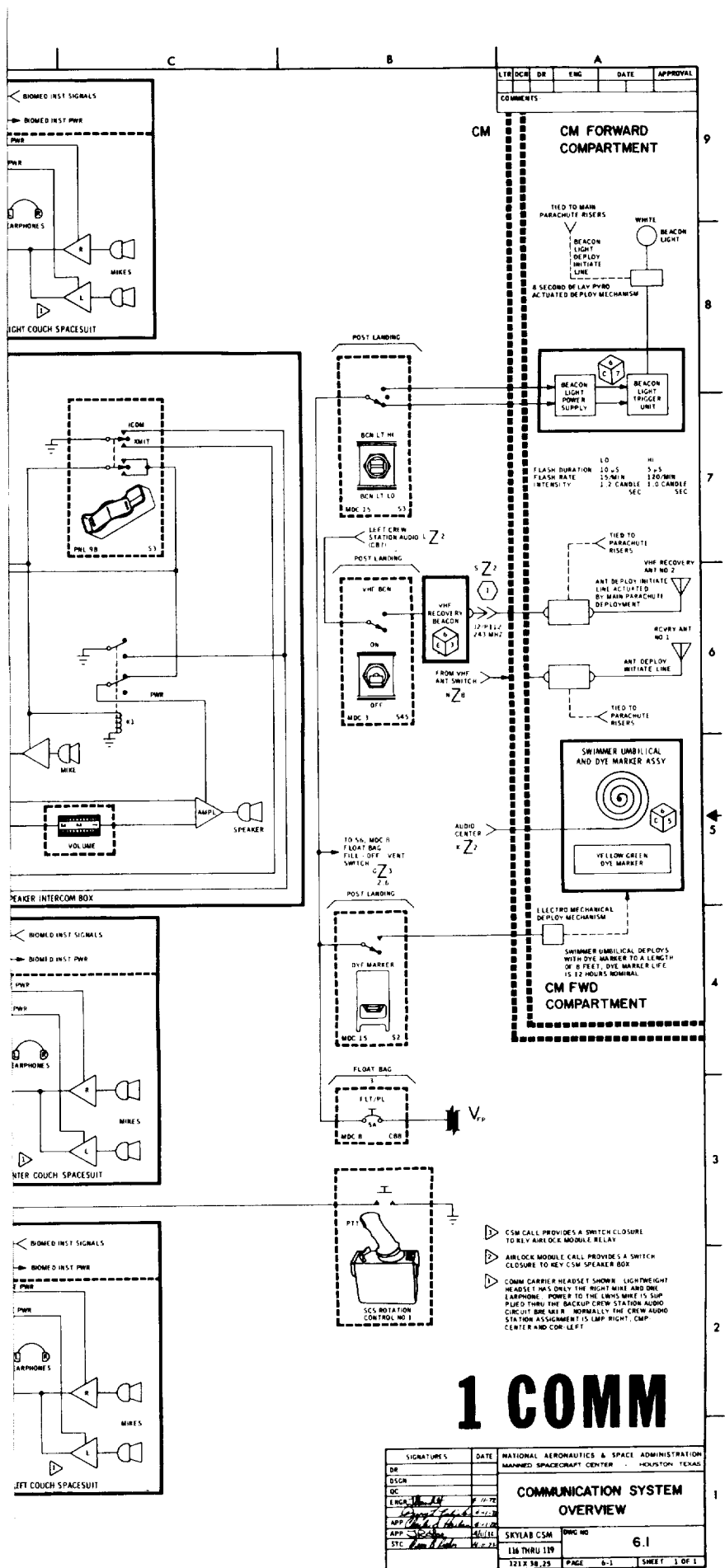

# 1 COMM

SIGNATURES	DATE	NATIONAL AERONAUTICS & SPACE ADMINISTRATION
DR		MANHATTAN SPACECRAFT CENTER HOUSTON TEXAS
ESC		
ENGR	8/11/72	
APP	8/11/72	
STC	8/11/72	
SKYLAB CSM		FIG NO
116 THRU 119		6.1
121X 58.25		PAGE 6-1 SHEET 1 OF 1

FOLDOUT FRAME 7



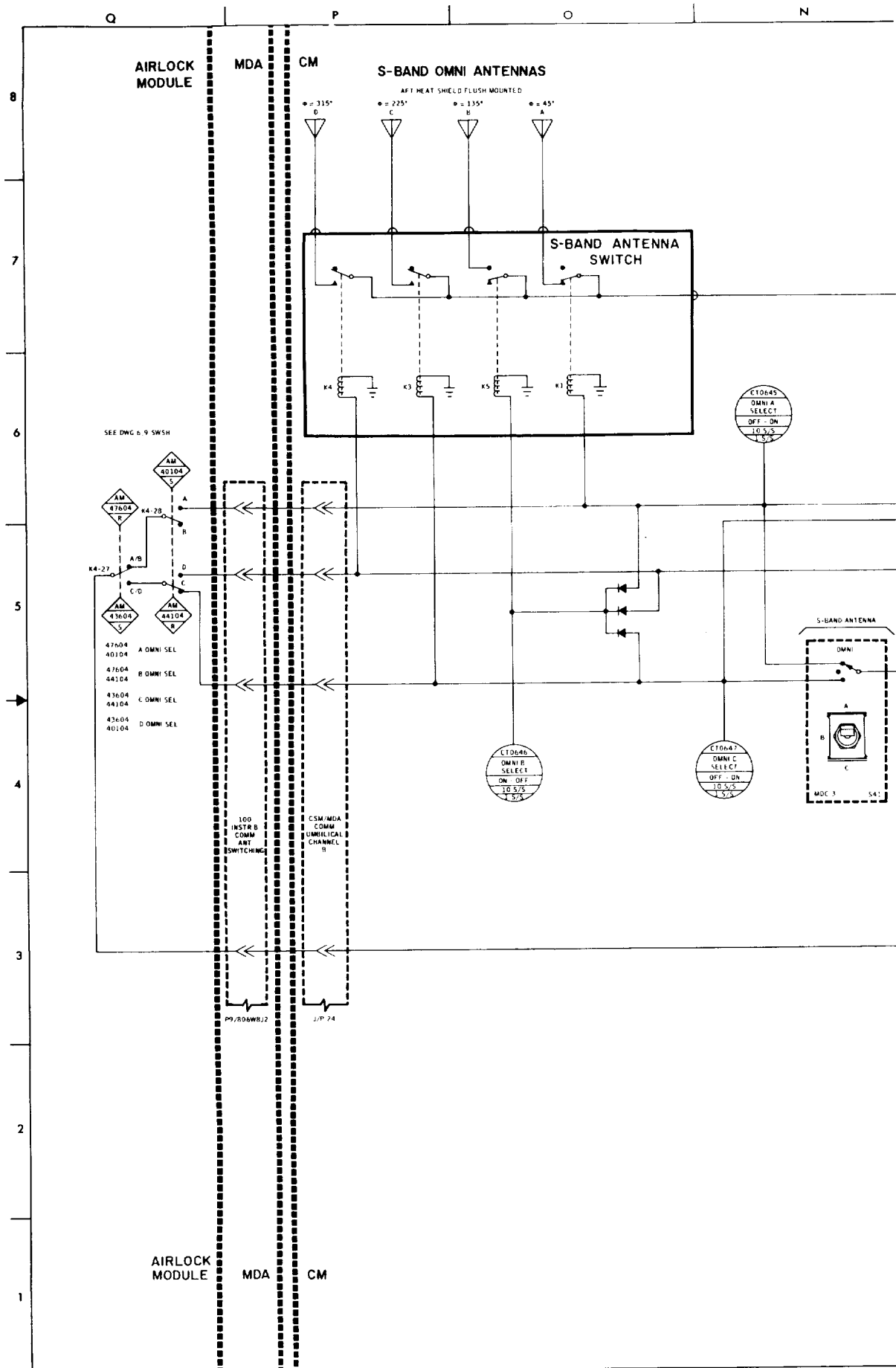

**FOLDOUT FRAME**

1. *Chlorophyll a*

1

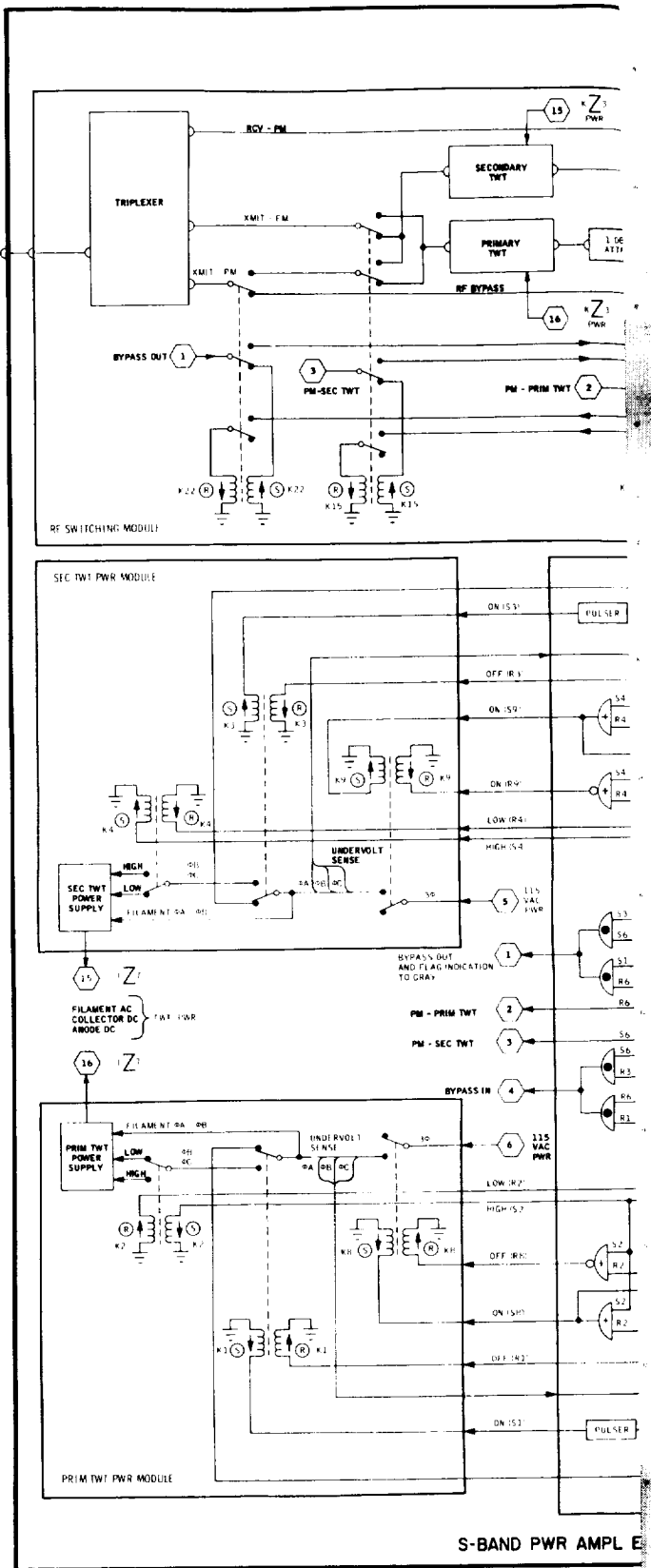
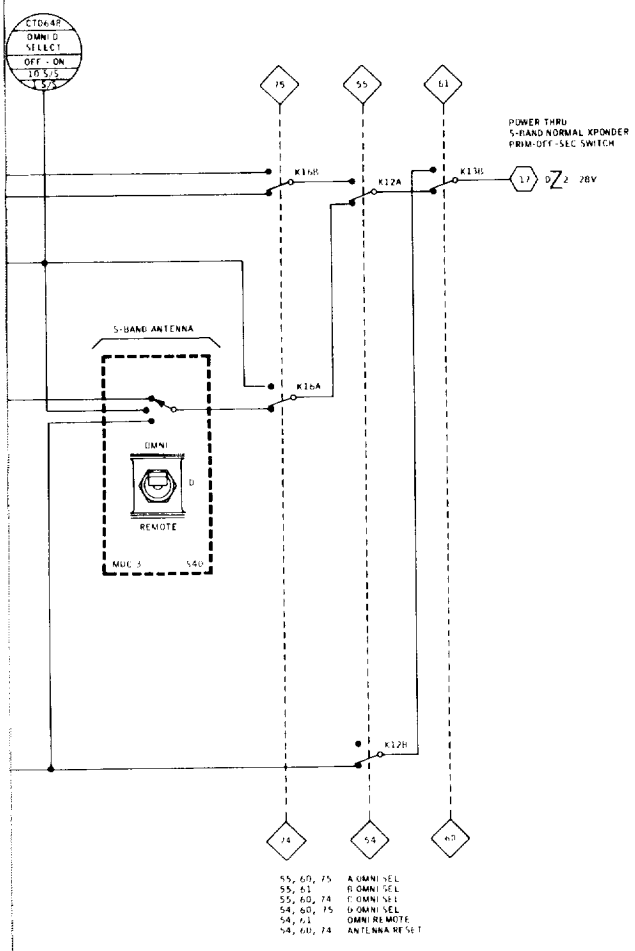

FOLDOUT FRAME 2





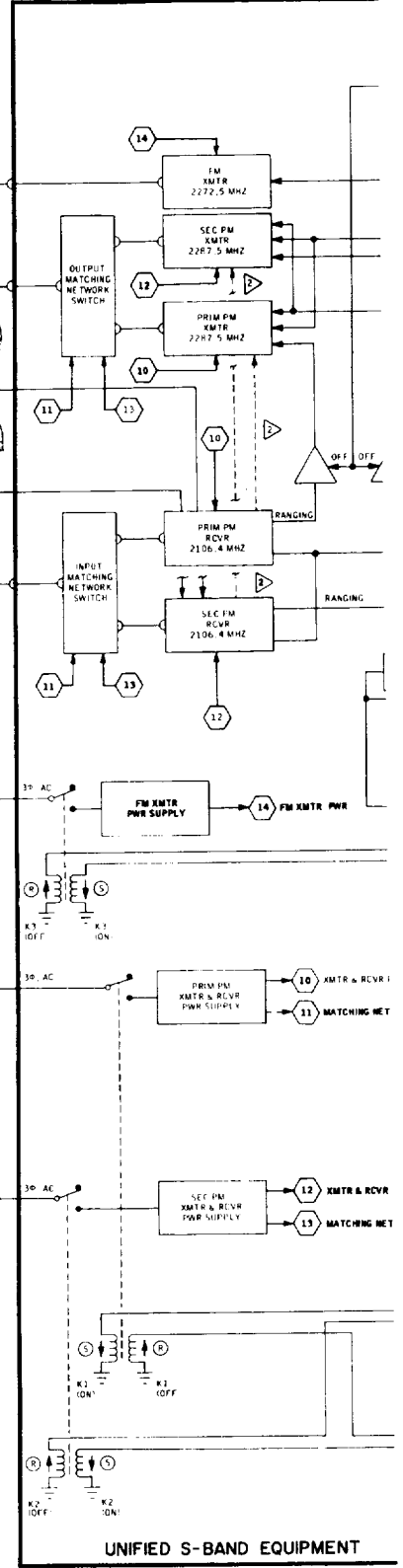
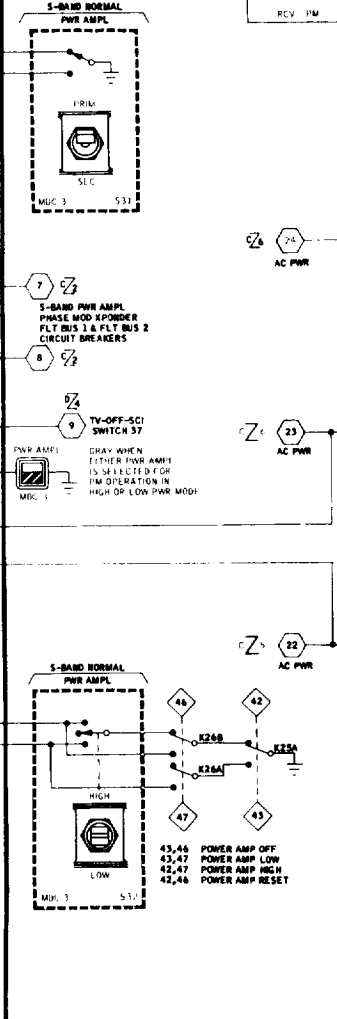
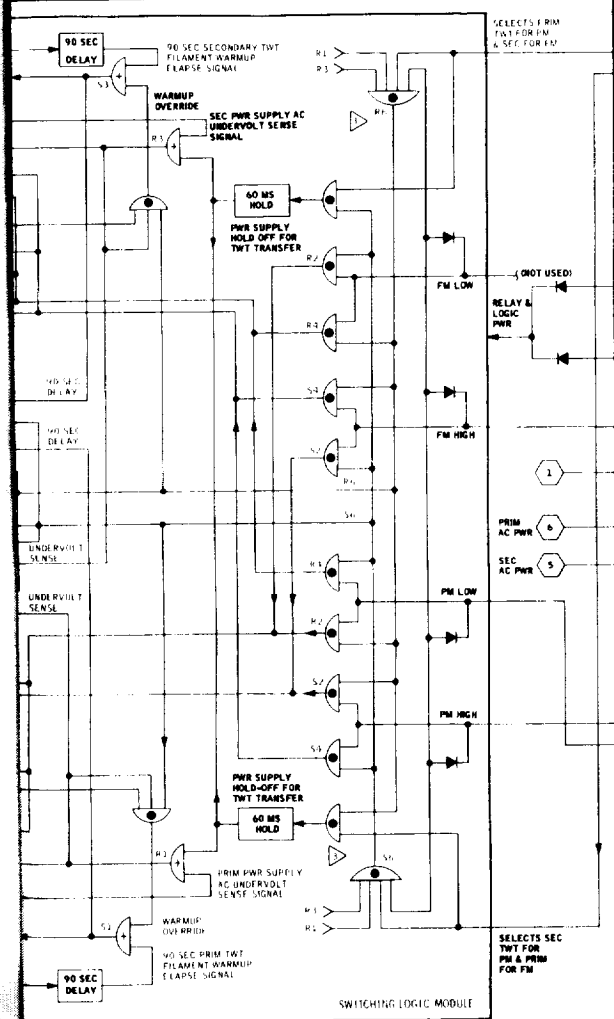
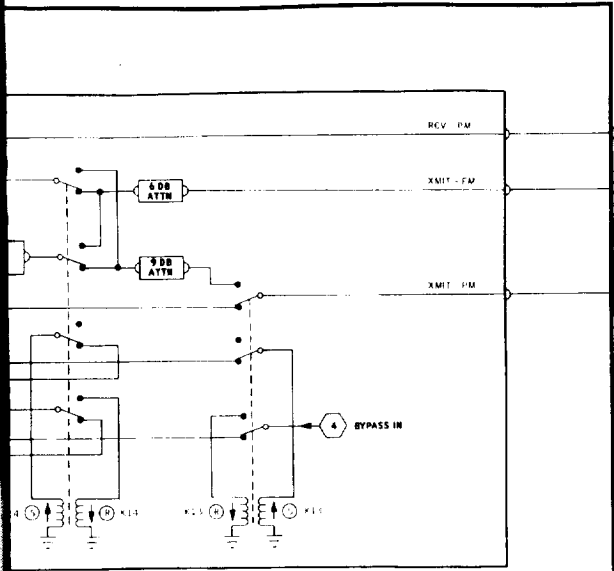

EQUIPMENT



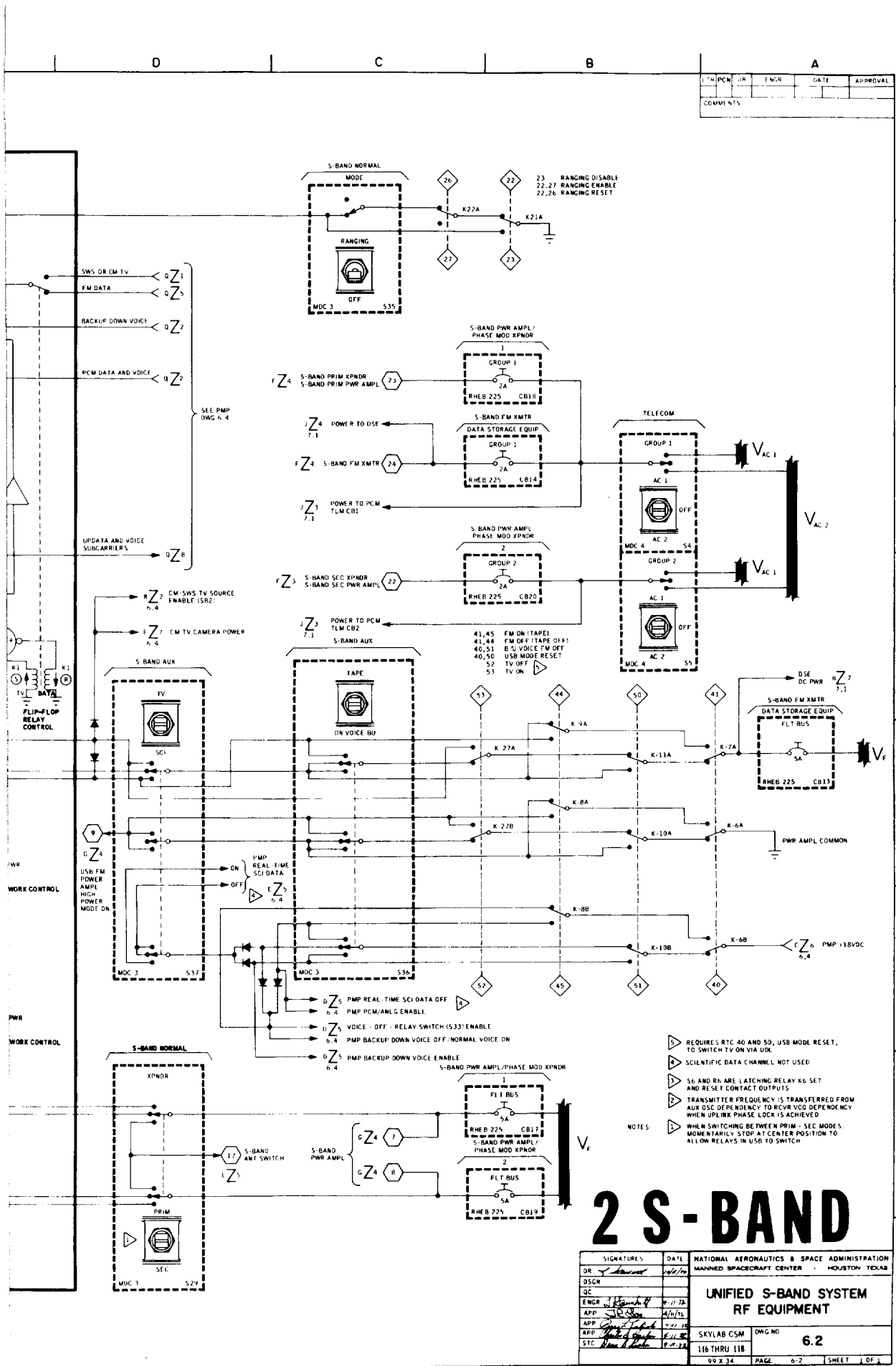

DATE	ENGR	DATE	APPROVAL

COMMENTS

# 2 S-BAND

SIGNATURES	DATE	NATIONAL AERONAUTICS & SPACE ADMINISTRATION MANNED SPACECRAFT CENTER - HOUSTON, TEXAS	
DR			
OSGN			
QC			
ENGR	8-11-73	UNIFIED S-BAND SYSTEM RF EQUIPMENT	
APP	8/22/73		
APP	8/22/73		
APP	8/22/73		
SEC	8/22/73	SKYLAB CSM	DWG NO. 6.2
		116 THRU 118	99 X 34 PAGE 6-2 SHEET 1 OF 4

FOLDOUT FRAME 4



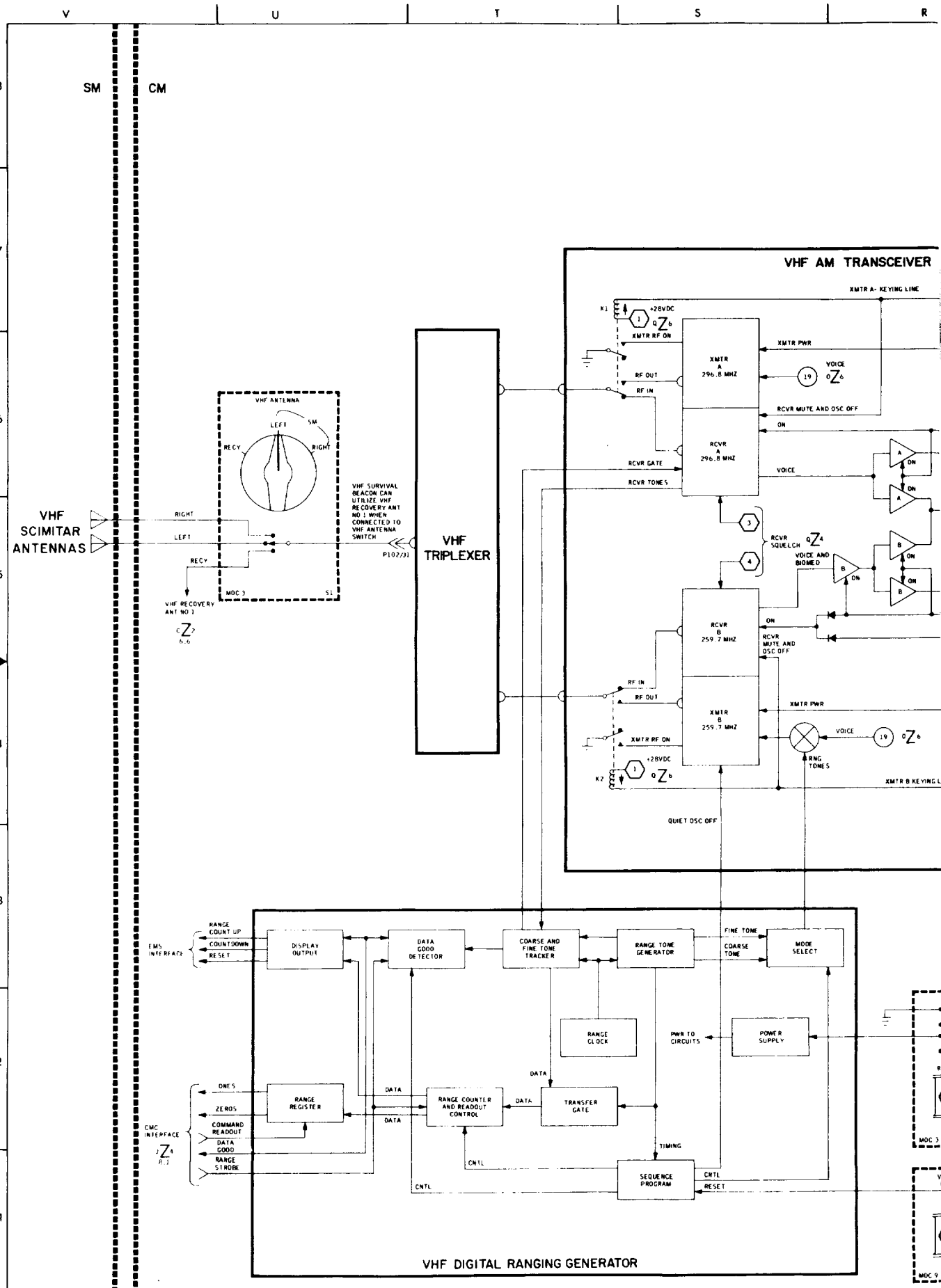

FOLDOUT FRAME



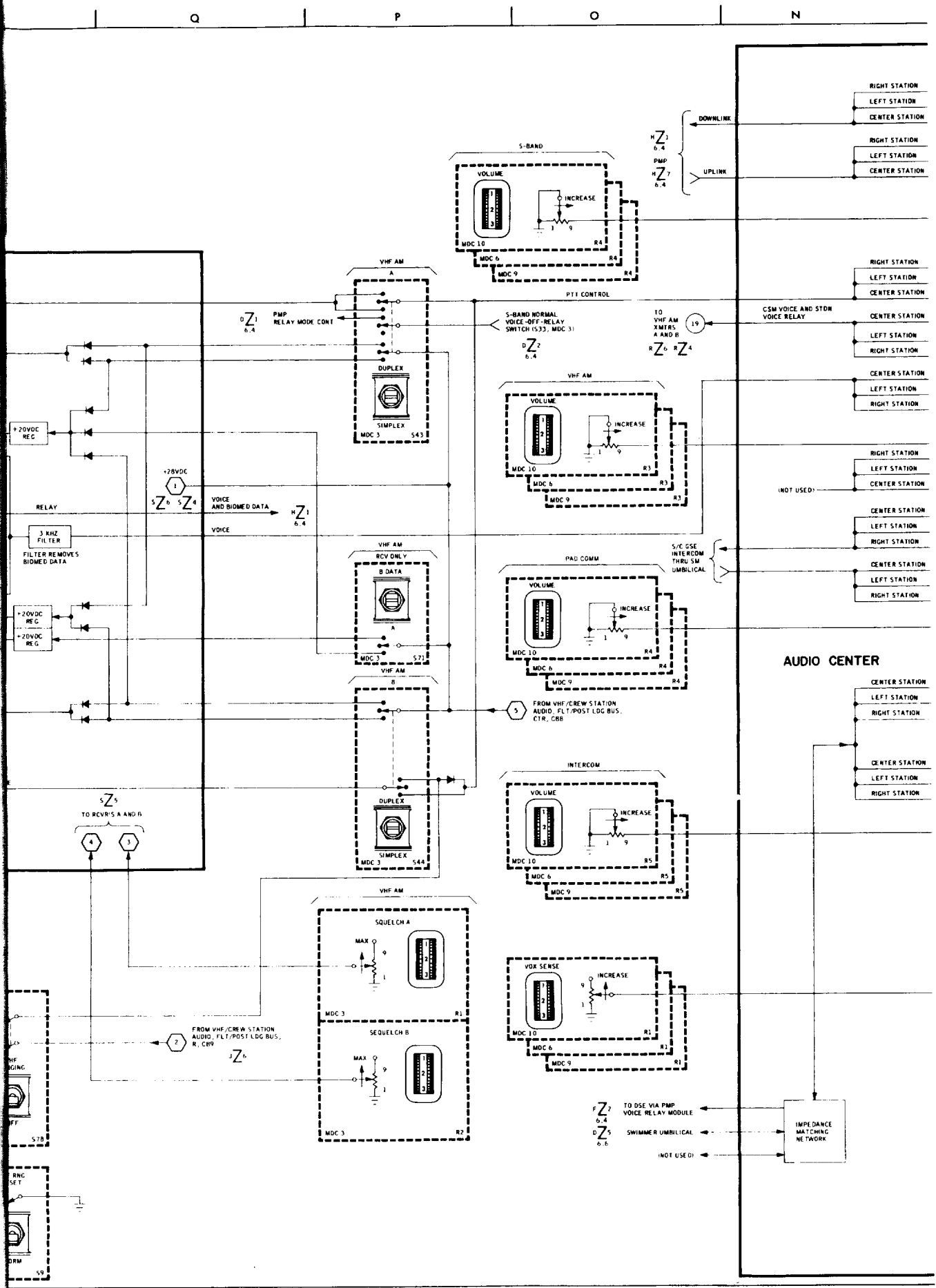

FOLDOUT FRAME 2





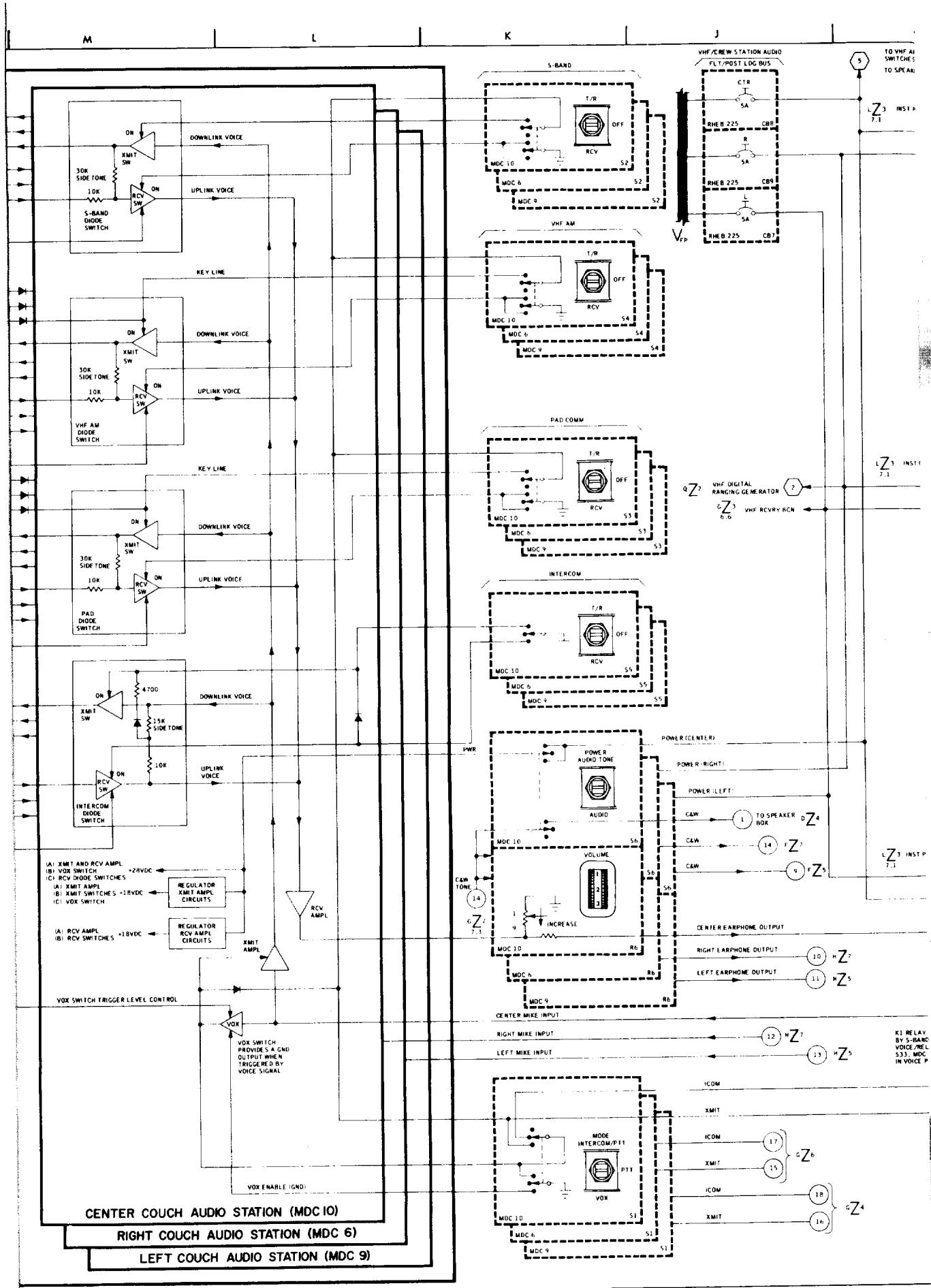

**FOLDOUT FRAME 3**



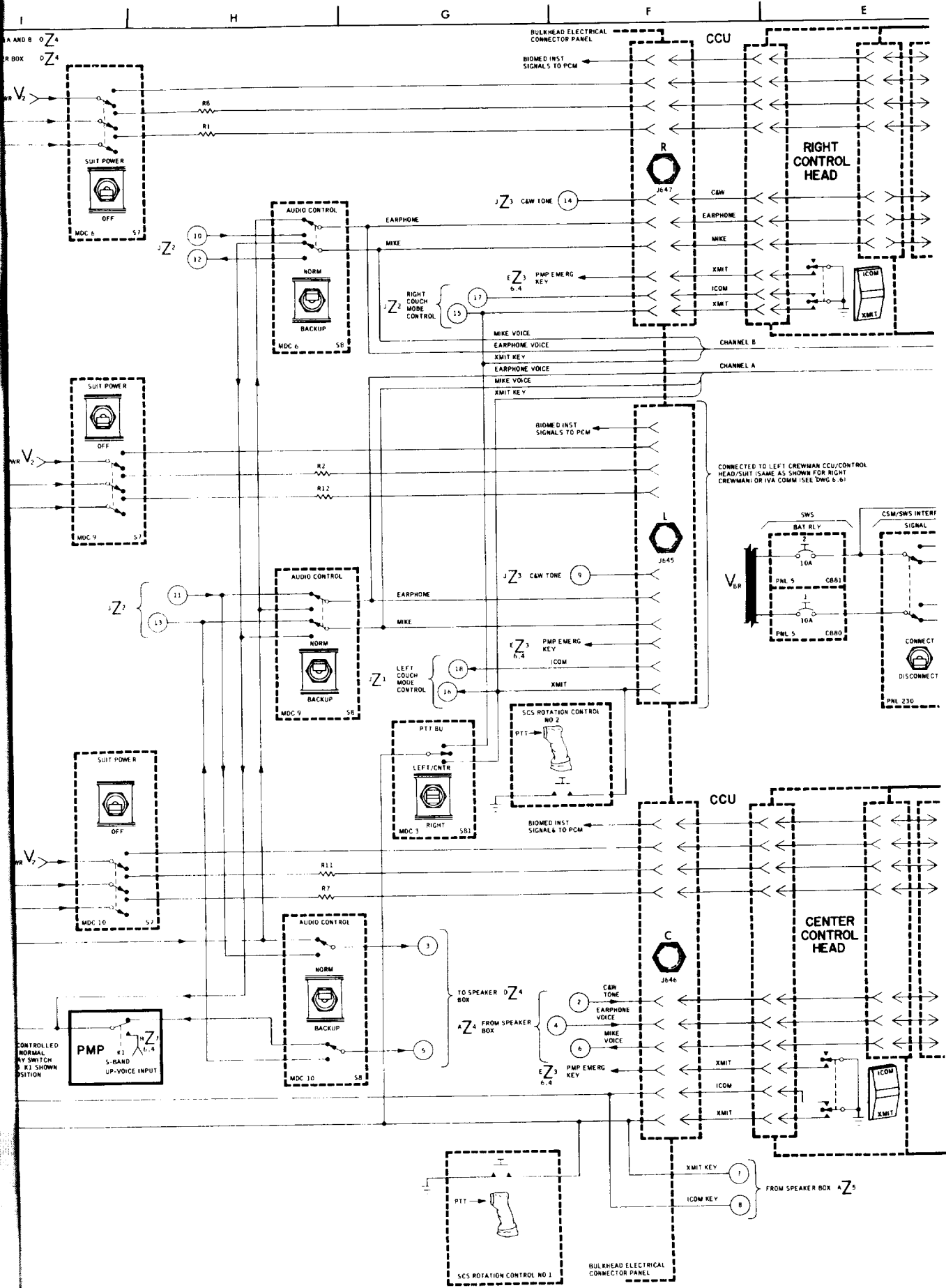



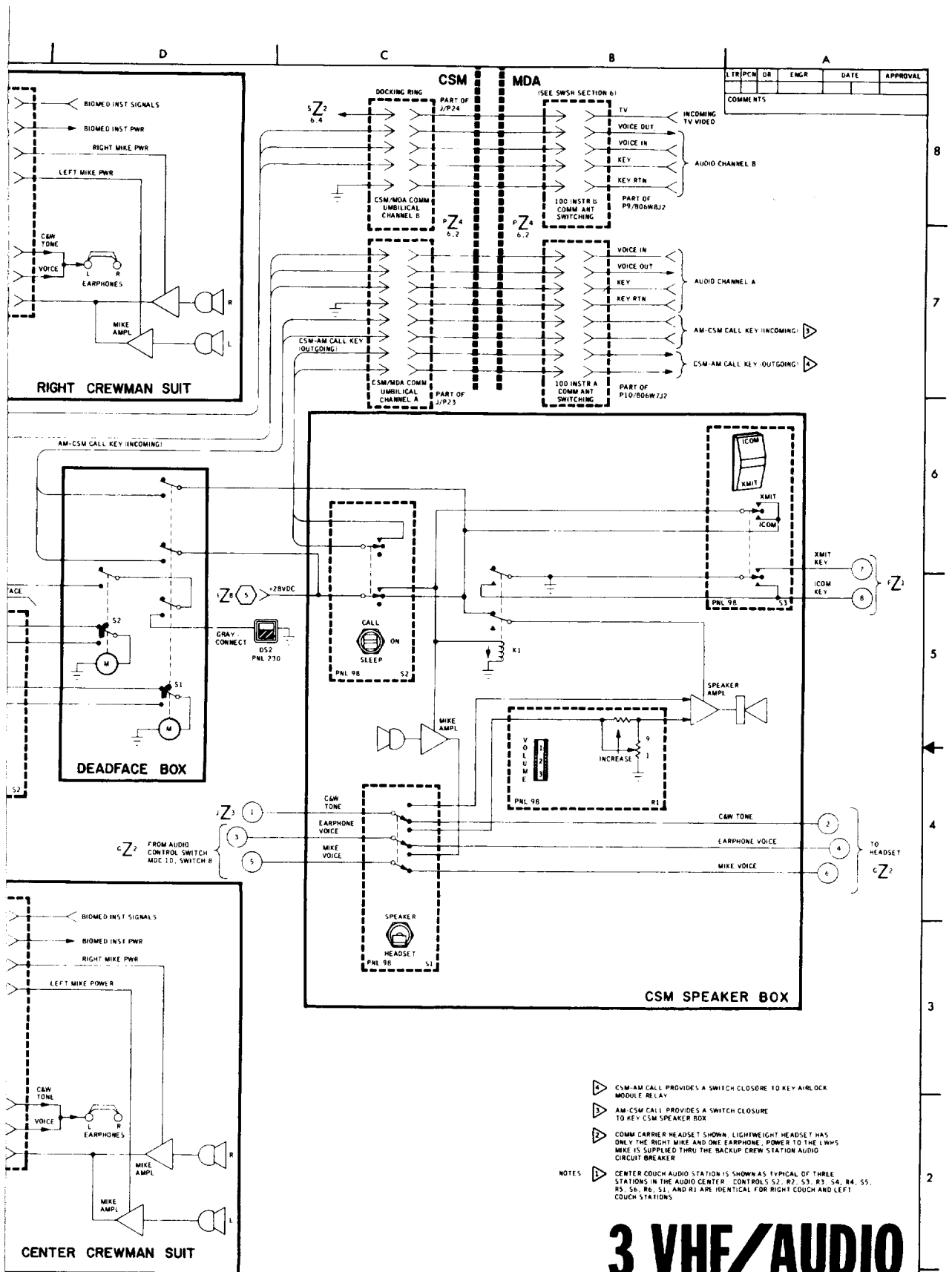

REV	PCB	DR	ENGR	DATE	APPROVAL

COMMENTS

- NOTES
- ▷ CSM-AM CALL PROVIDES A SWITCH CLOSURE TO KEY AIRBLOCK MODULE RELAY
  - ▷ AM CSM CALL PROVIDES A SWITCH CLOSURE TO KEY CSM SPEAKER BOX
  - ▷ COMM CARRIER HEADSET SHOWN. LIGHTWEIGHT HEADSET HAS ONLY THE RIGHT MIKE AND ONE EARPHONE. POWER TO THE LHM'S MIKE IS SUPPLIED THRU THE BACKUP CREW STATION AUDIO CIRCUIT BREAKER
  - ▷ CENTER COUCH AUDIO STATION IS SHOWN AS TYPICAL OF THREE STATIONS IN THE AUDIO CENTER. CONTROLS S2, R2, S3, R3, S4, R4, S5, S5, S6, R6, S1, AND R1 ARE IDENTICAL FOR RIGHT COUCH AND LEFT COUCH STATIONS

# 3 VHF/AUDIO

SIGNATURES	DATE	NATIONAL AERONAUTICS & SPACE ADMINISTRATION MANNED SPACECRAFT CENTER HOUSTON, TEXAS	
DSGN	5/17/72	<b>SKYLAB CSM VHF AM TRANSCIVERS AND AUDIO EQUIPMENT</b>	
QC			
ENGR	6/11/72		
APP	6/17/72		
STC	8/21/72		
SKYLAB CSM		DWG NO	6.3
116 THRU 119		121 K 14 PAGE 6-3 SHEET 1 OF 1	

EQLDOUT FRAME 5

2023

2023

V U T S

8  
7  
6  
5  
4  
3  
2  
1

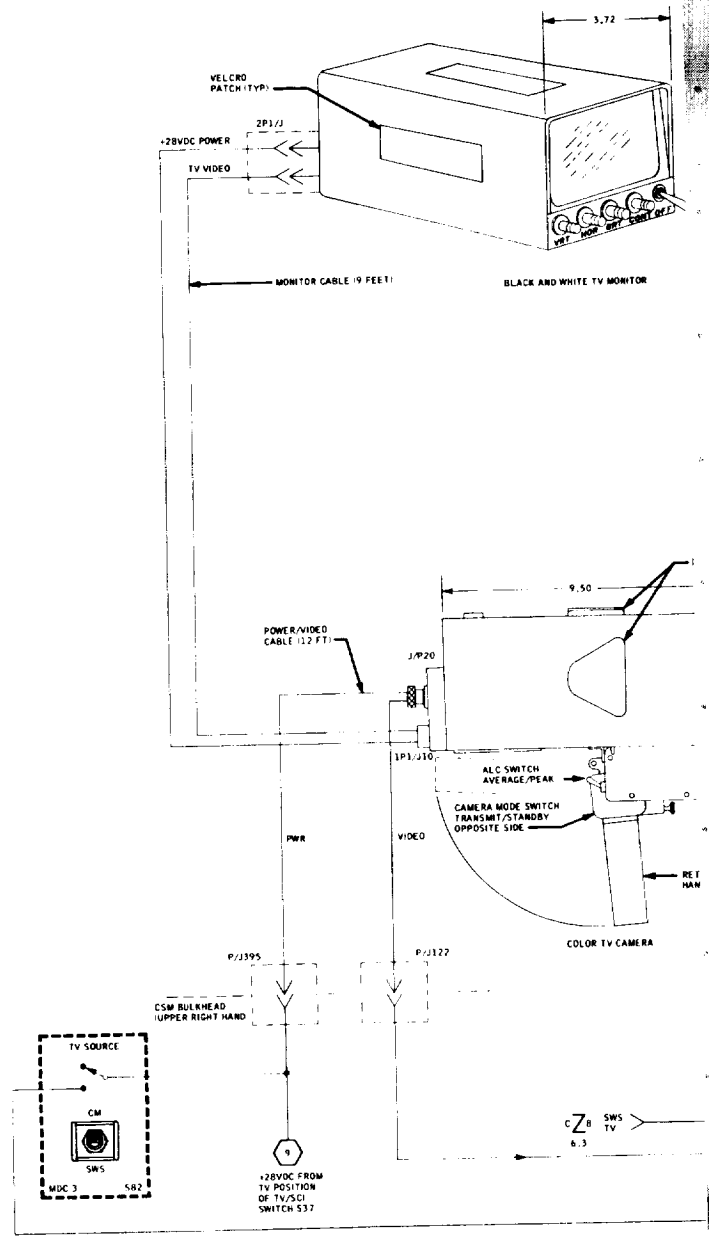

FOLDOUT FRAME





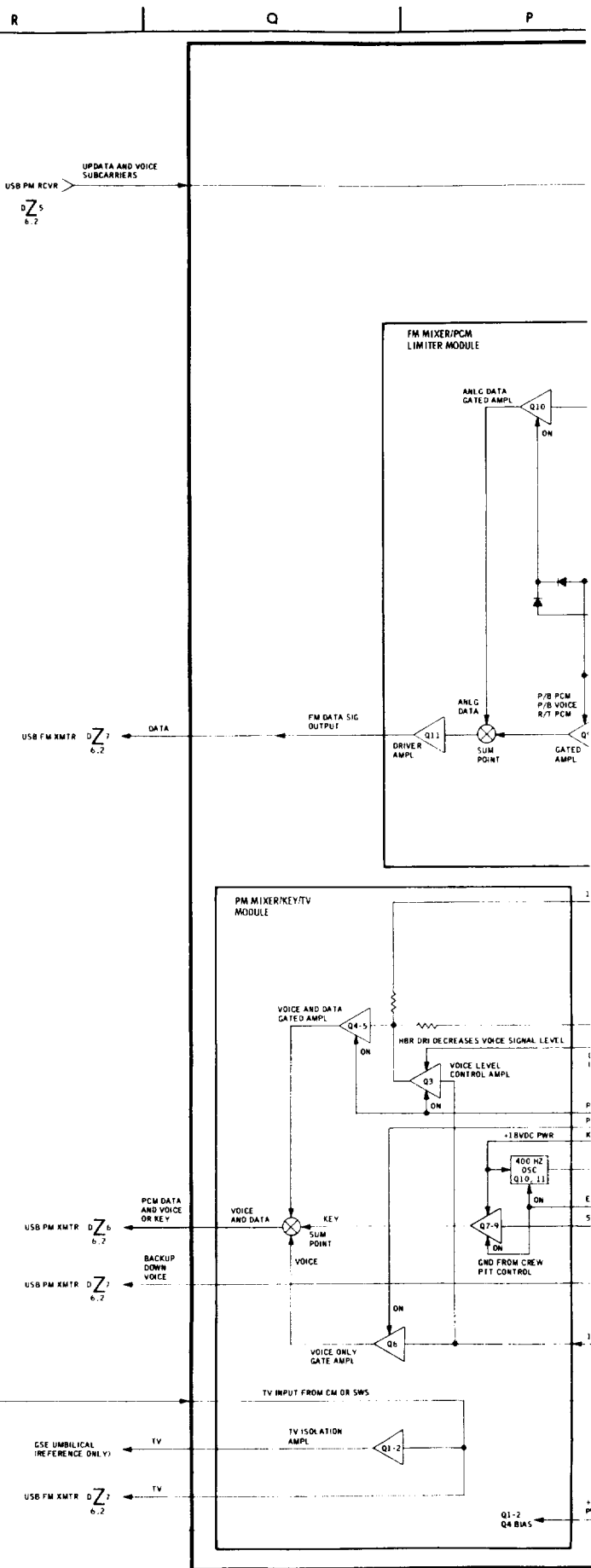

FOLDOUT FRAME 2



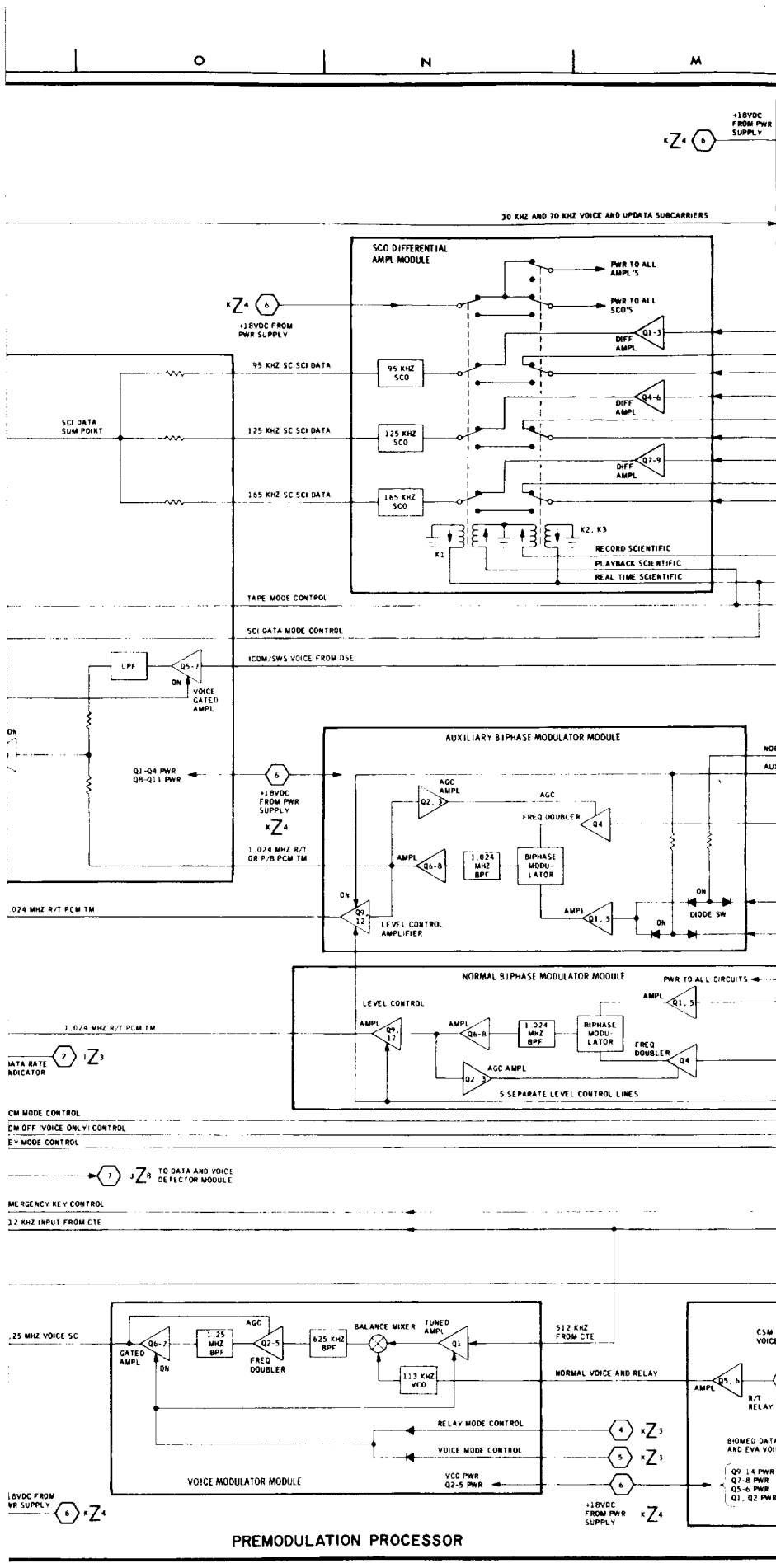



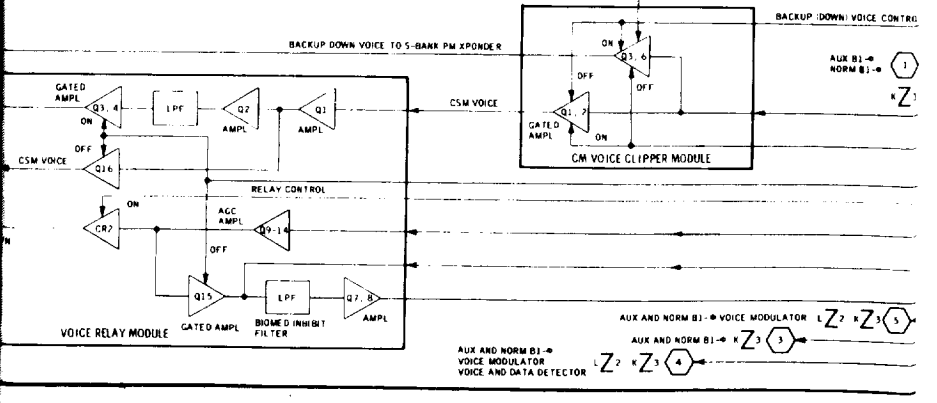
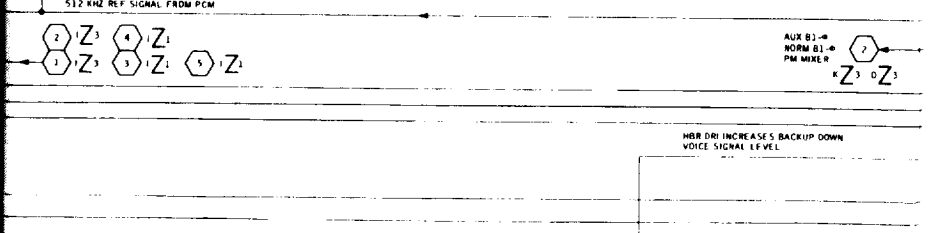
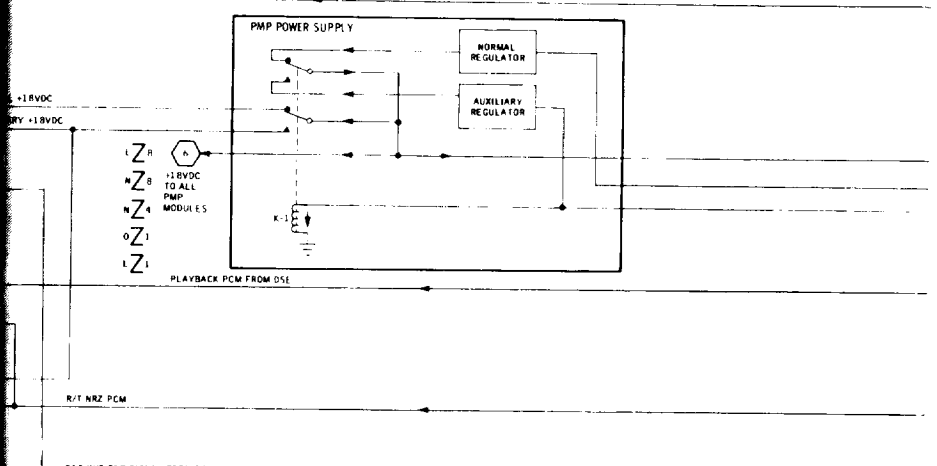
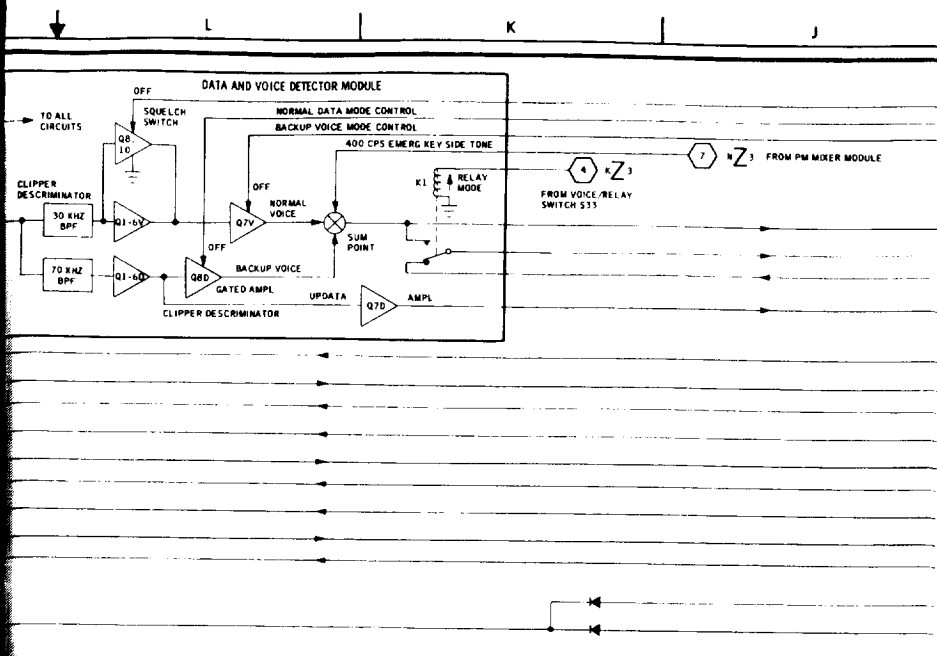



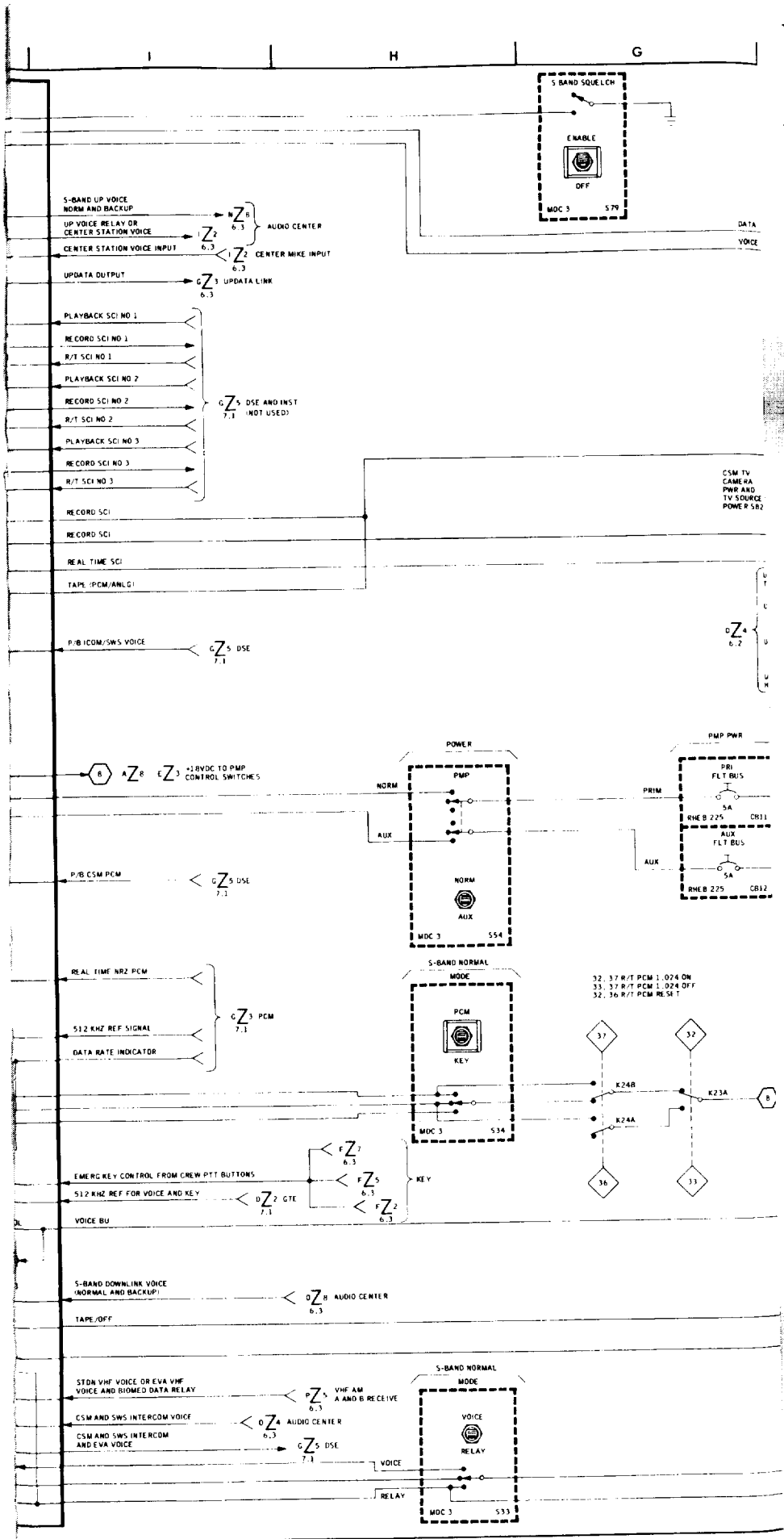

FOLDOUT FRAME 5





F

E

D

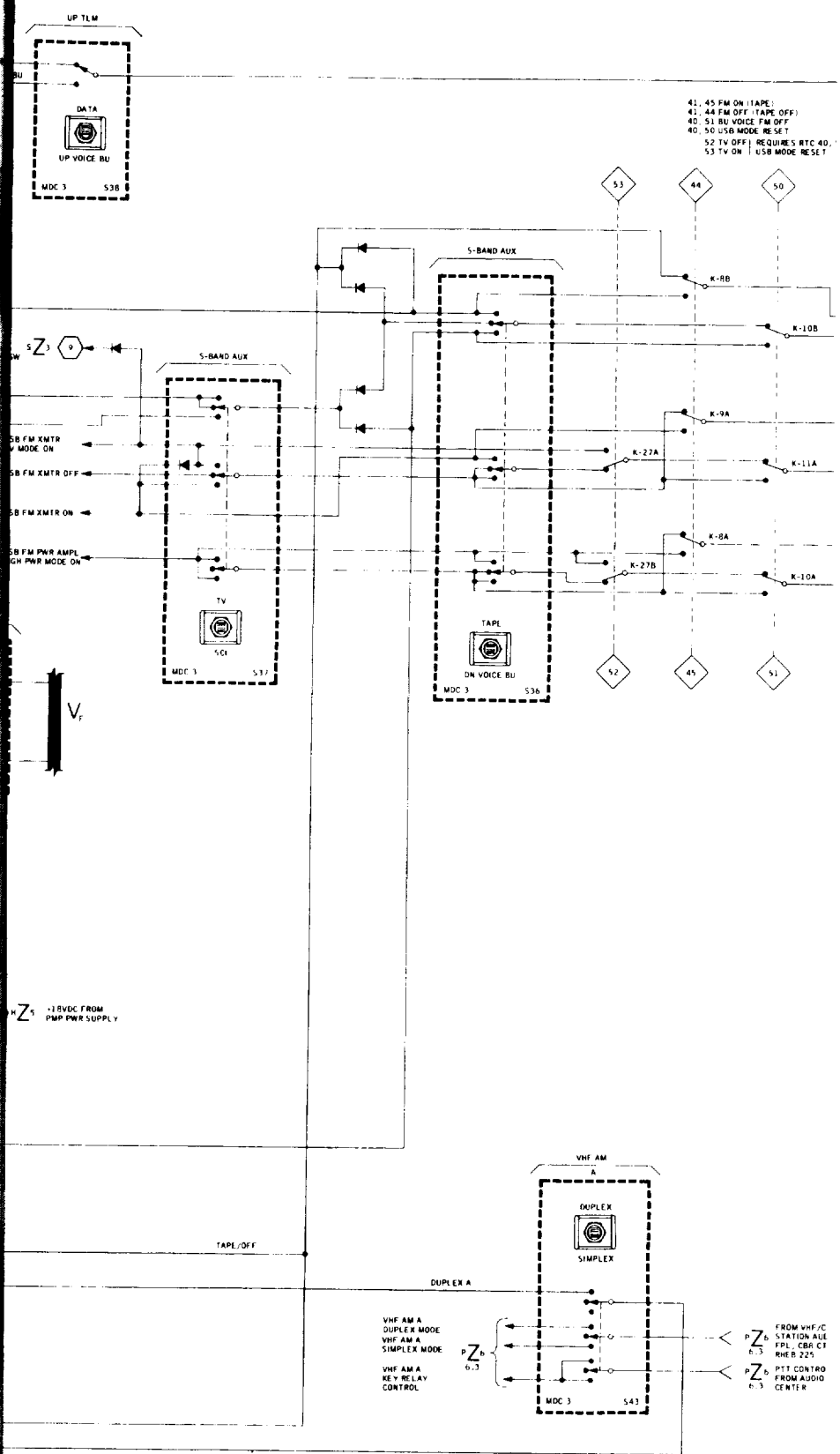

FOLDOUT FRAME 6



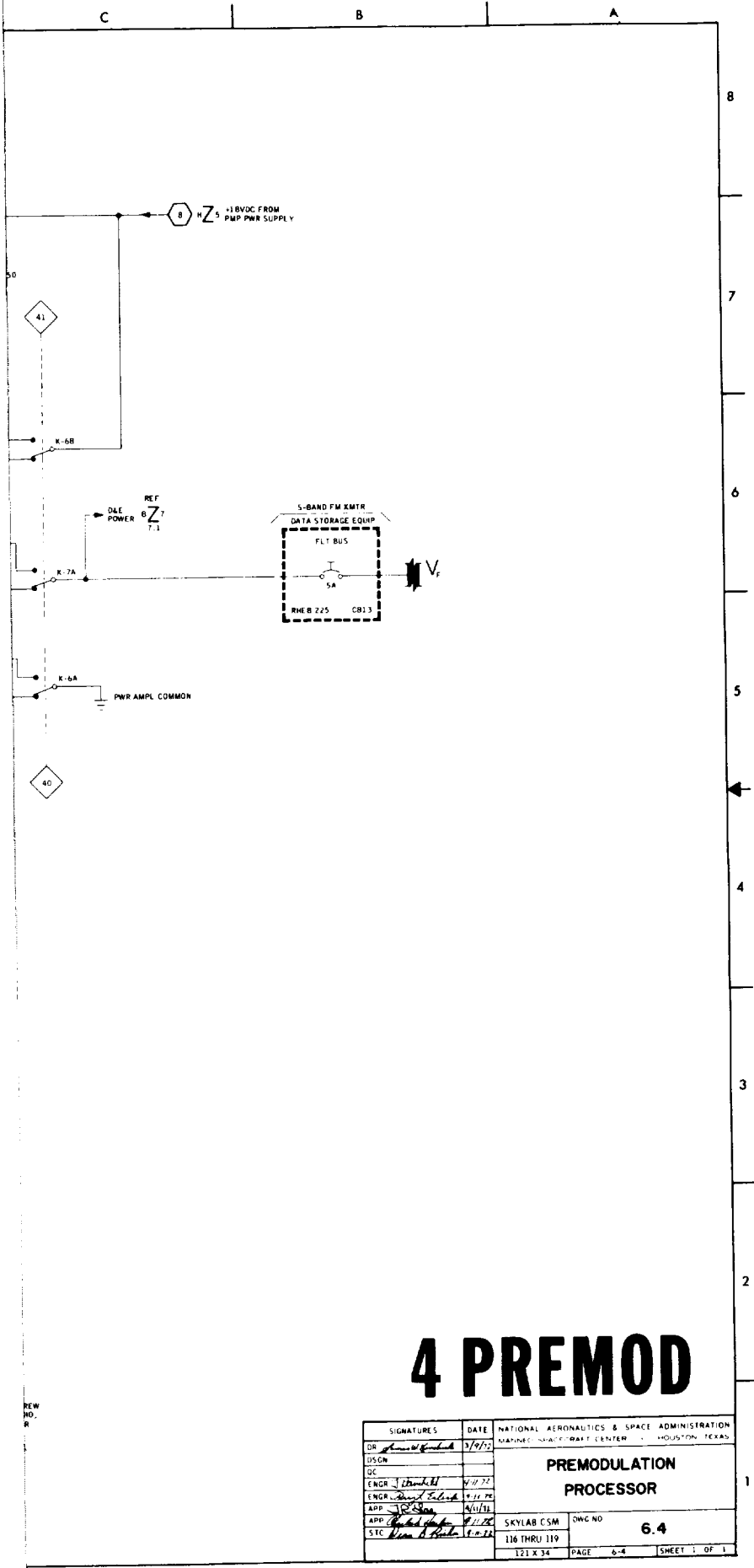

# 4 PREMOD

REV  
NO.  
R

SIGNATURES		DATE	NATIONAL AERONAUTICS & SPACE ADMINISTRATION	
DR	<i>[Signature]</i>	3/9/72	MARINE CORPS CENTER - HOUSTON, TEXAS	
DSCN			<b>PREMODULATION PROCESSOR</b>	
DC				
ENGR	<i>[Signature]</i>	4/11/72		
ENGR	<i>[Signature]</i>	4/11/72		
APP	<i>[Signature]</i>	4/11/72	SKYLAB CSM DWC NO.	
STC	<i>[Signature]</i>	4/11/72	<b>6.4</b>	
			116 THRU 119	
			121 X 34	PAGE 6-4 SHEET 1 OF 1

**FOLDOUT FRAME 7**



SALVO REALTIME COMMAND LIST		UDL RELAY MODL REALTIME COMMA	
SALVO RESET (OCTAL) (4XXX)	SALVO FUNCTION	RTC (OCTAL) (46XX)	COMMAND NAME
SALVO RESET 1: RESETS FOLLOWING RTC'S 46XX			
30	00 ABORT LIGHT A OFF 06 CREW ALARM OFF 10 ACE CMC ZERO DISABLE 14 ACE CMC ONE DISABLE 20 CSM SPEC ELC PWR OFF	00	ABORT LIGHT A OFF
12	02 NORM MEM DUMP OFF 08 ABORT LIGHT B OFF 12 (SPARE) 16 VG INIT-CLK U/D OFF 22, 26 RANGING RESET 32, 36 R/T PCM RESET	01	ABORT LIGHT A ON
SALVO RESET 2: RESETS FOLLOWING RTC'S 46XX			
70	40, 50 USB MODE RESET 44 NG EQUIPMENT AFFECTED 54, 60, 74 ANTENNA SELECT RESET 64, 70 BIT RATE RESET	02	NORM MEM DUMP OF
72	42, 46 POWER AMP RESET 52 TV OFF 56 CSM SPEC DET PWR OFF 62, 66 DSE EJECT RESET 72, 76 TAPE CTRL RESET	03	NORM MEM DUMP DN
SALVO COMMAND (OCTAL) (45XX)      RTC INITIATED			
10	00, 04, 10, 14	10	ACE CMC ZERO DSA
11	01, 05, 11, 15	11	ACE CMC ZERO ENAB
12	02, 06, 12, 16	14	ACE CMC ONE DISAB
13	03, 07, 13, 17	15	ACE CMC ONE ENAB
14	04, 14	16	VG INIT-CLK U/D OFF
15	05, 15	17	VG INIT-CLK U/D ON
16	06, 16	20	CSM SPEC ELC PWR
17	07, 17, 23, 37	21	CSM SPEC ELC PWR
20	00, 04, 10, 14, 20	22, 26	RANGING RESET
31	01, 05, 11, 15, 21	22, 27	RANGING ENABLE
32	02, 06, 12, 16, 22, 26, 32, 36	23	RANGING DISABLE
33	03, 07, 13, 17, 23, 27, 33, 37	24	(NOT USABLE)
34	04, 14	25	(NOT USABLE)
35	05, 15	30	(NOT USABLE)
36	06, 16, 26, 36	31	(NOT USABLE)
37	07, 17, 23, 37	32, 36	R/T PCM RESET
40	40, 44, 50, 54	32, 37	R/T PCM I, O24 ON
51	41, 45, 51, 55	33, 37	R/T PCM OFF
52	42, 46, 52, 56	34	(NOT USABLE)
53	43, 47, 53, 57	35	(NOT USABLE)
54	44, 54	40, 50	USB MODE RESET
55	45, 55	40, 51	B/V VOICE FM OFF
56	46, 56	41, 44	FM OFF (TAPE OFF)
57	47, 57	41, 45	FM ON (TAPE ON)
10	40, 44, 50, 54, 60, 64, 70, 76	42, 46	POWER AMP RESET
11	41, 45, 51, 55, 61, 65, 71, 75	42, 47	POWER AMP HIGH
12	42, 46, 52, 56, 62, 66, 72, 76	43, 46	POWER AMP OFF
13	43, 47, 53, 57, 63, 67, 73, 77	43, 47	POWER AMP LOW
14	44, 54, 64, 74	52	TV OFF
15	45, 55, 65, 75	53	TV ON
16	46, 56, 66, 76	54, 60, 74	ANTENNA SEL
17	47, 57, 67, 77	54, 60, 75	D OMNI SELEC
* THESE SALVO'S NOT USED			
54, 61 REMOTE			
55, 60, 74 C OMNI SELEC			
55, 60, 75 R OMNI SELEC			
55, 61 R OMNI SELEC			
56 CSM SPEC DET PWR			
57 CSM SPEC DET PWR			
62, 66 DSE EJECT RESET			
62, 67 DSE EJECT RECORD			
63, 66 DSE EJECT OFF			
63, 67 DSE EJECT PLAYBACK			
64, 70 BIT RATE RESET			
64, 71 BIT RATE HIGH			
65 BIT RATE LOW			
72, 76 TAPE CTRL RESET			
72, 77 DSE TAPE FORWARD			
73, 76 DSE TAPE STOP			
73, 77 DSE TAPE REWIND			

FOLDOUT FRAME

3-11-2011

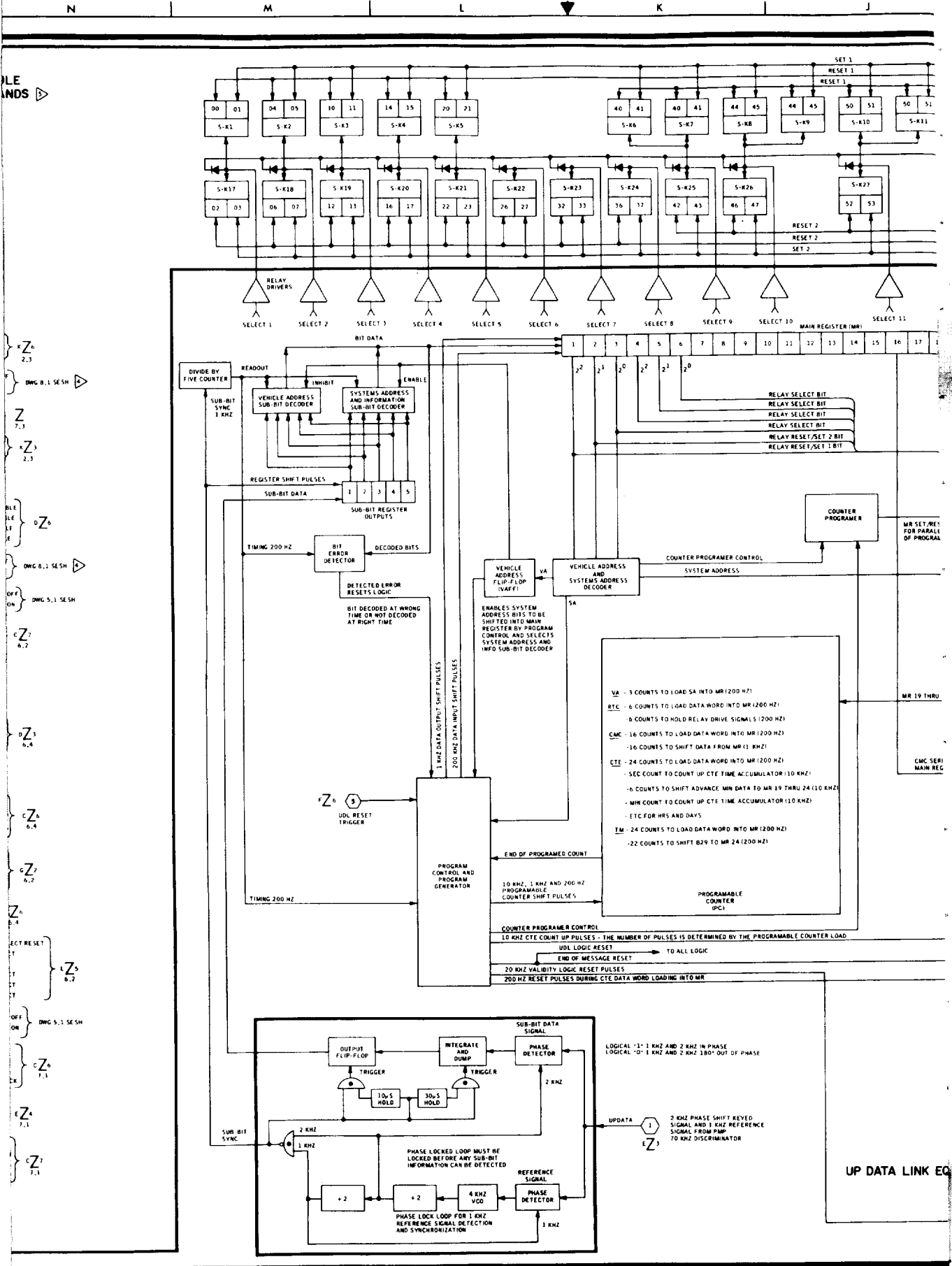

FILE ENDS

DWG. 8.1.1 SE SH

Z 7.3

X Z 2.3

D Z 6

DWG. 8.1.1 SE SH

DWG. 5.1 SE SH

Z 6.2

D Z 6.4

Z 6.4

C Z 6.2

Z 6.4

C Z 6.2

Z 6.4

ECT RESET

Z 8.7

DWG. 5.1 SE SH

Z 7.1

Z 7.1

Z 7.1





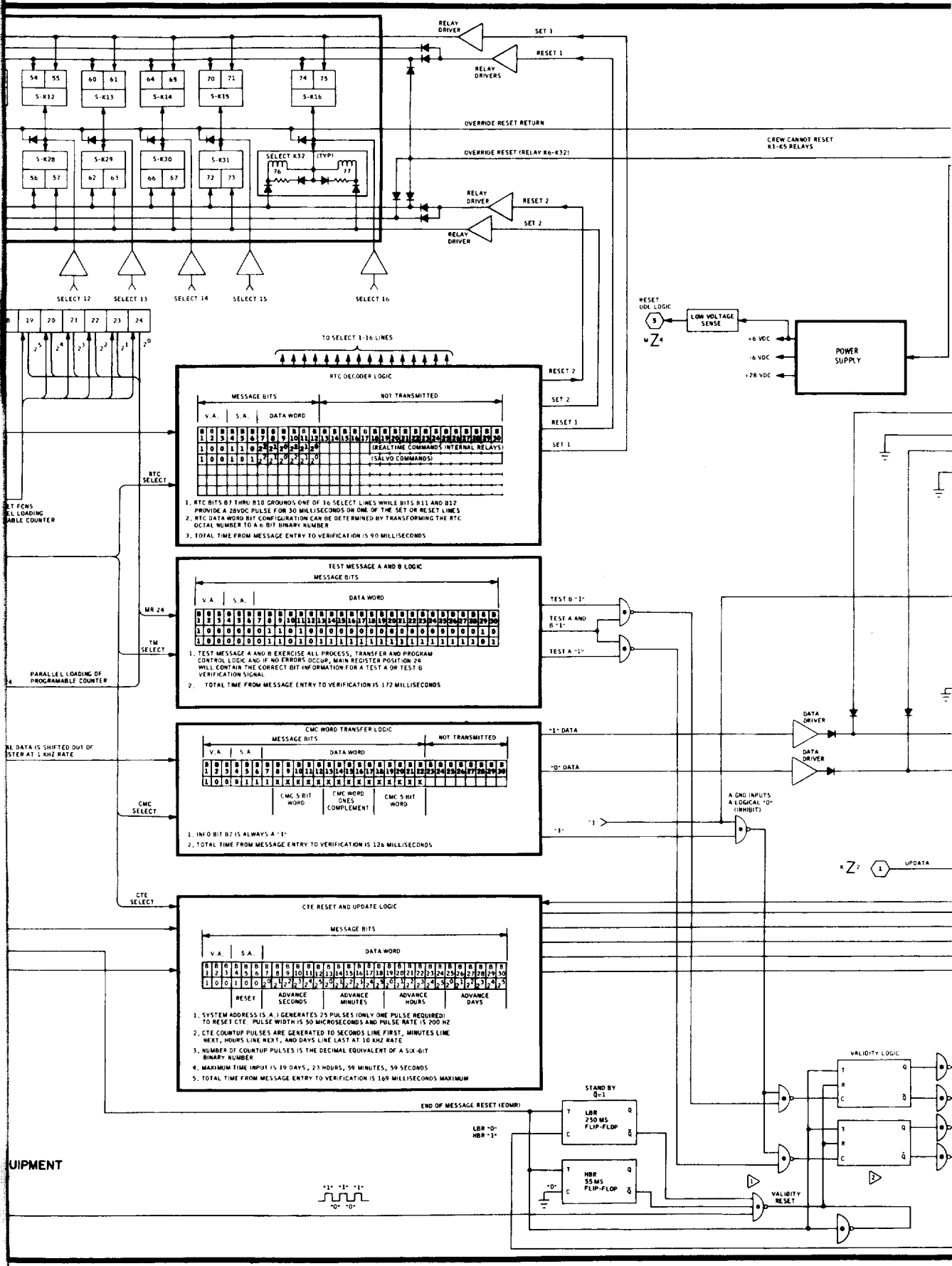



LT/DCN	DR	ENG	DATE	APPROVAL

COMMENTS:

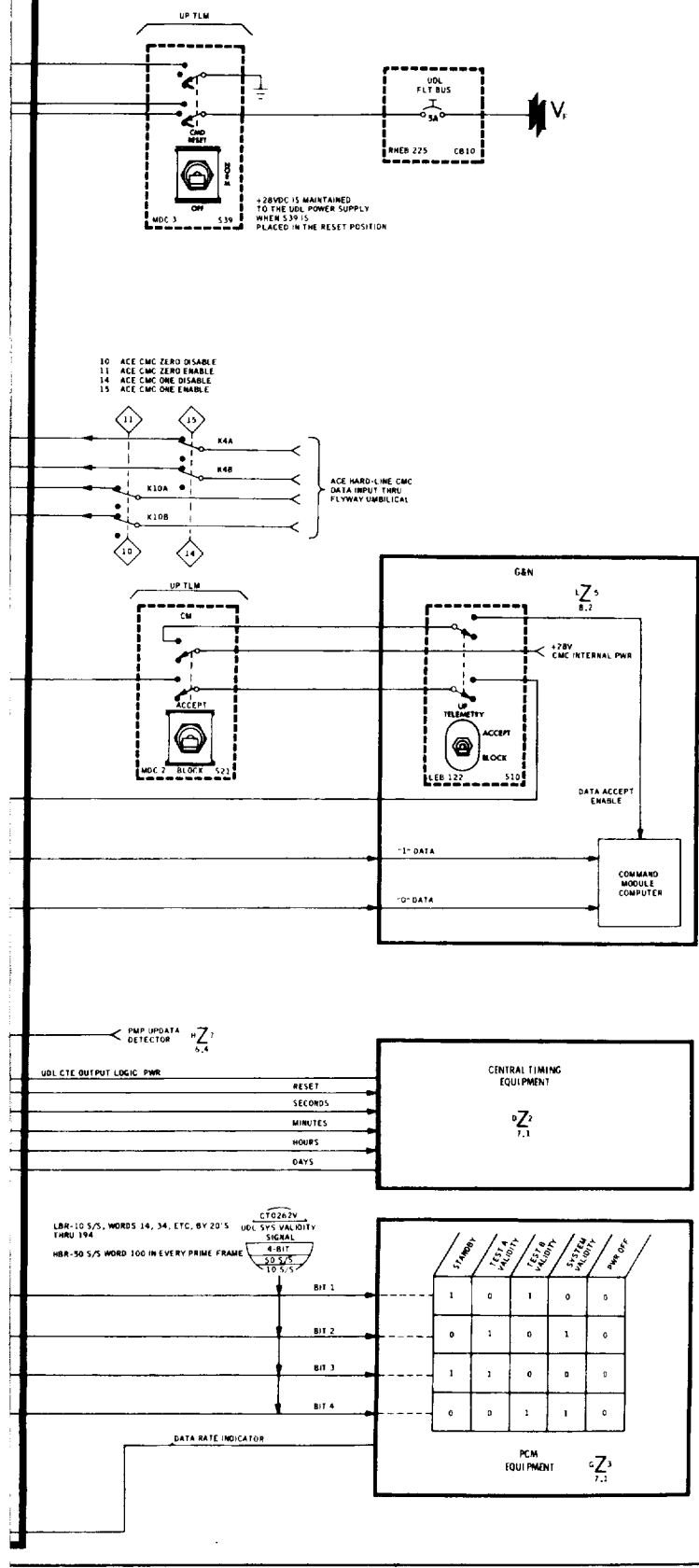

- ▶ UDL RELAY CONTACTS ARE SHOWN ON INDIVIDUAL USER DRAWINGS AS REFERENCED IN COMMAND 1157
- ▶ THESE COMMANDS ARE UTILIZED IN THIS CONFIGURATION ONLY IN CSM 117 FOR SD71/72
- ▶ NO SCIENTIFIC DATA IN THIS SPACECRAFT USING SUBCARRIER OSCILLATORS
- ▶ IF C = '0' THEN Q = '0' AND IF C = '1' THEN Q = '1' WHEN FOUR TRIGGERS 1 INPUT IF Q = '0' THEN Q = '1' AND IF Q = '1' THEN Q = '0'
- ▶ IN STANDBY Q = '1' ON BOTH FLIP-FLOPS AND VALIDITY LOGIC RESET SIGNAL CONTINUALLY RESETS VALIDITY LOGIC WITH EACH '0' TO '1' TRANSITION DURING VALIDITY PERIOD WHEN EITHER Q = '0' THE RESET FUNCTION IS INHIBITED UNTIL THE FLIP-FLOP TIMES OUT

# 5 UPDATA

SIGNATURES		DATE	NATIONAL AERONAUTICS & SPACE ADMINISTRATION	
DR <i>P.A. Dwyer</i>		11/76	MANNED SPACECRAFT CENTER - HOUSTON, TEXAS	
DC			<b>UPDATA LINK</b>	
ENGR <i>A. J. ...</i>		11/76		
APP <i>...</i>		11/76		
STC <i>...</i>		11/76		
SKYLAB CSM		OWC NO	<b>6.5</b>	
118 THRU 119				
95.3 X 34		PAGE 6-5	SHEET 1 OF 1	

FOLDOUT FRAME 4



8  
7  
6  
5  
4  
3  
2  
1

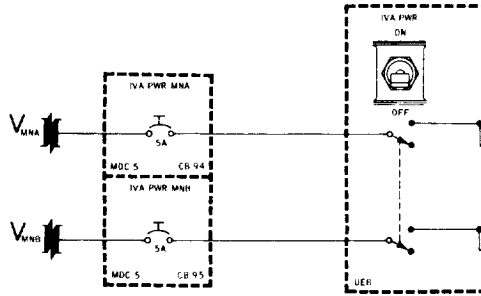

$\sum_{0.3}^2$   
 CONNECT TO  
 AUDIO CENTER  
 INTERFACE CONNECTOR  
 J645 LEFT AUDIO CENTER  
 J646 CENTER AUDIO CENTER  
 OR  
 J647 RIGHT AUDIO CENTER

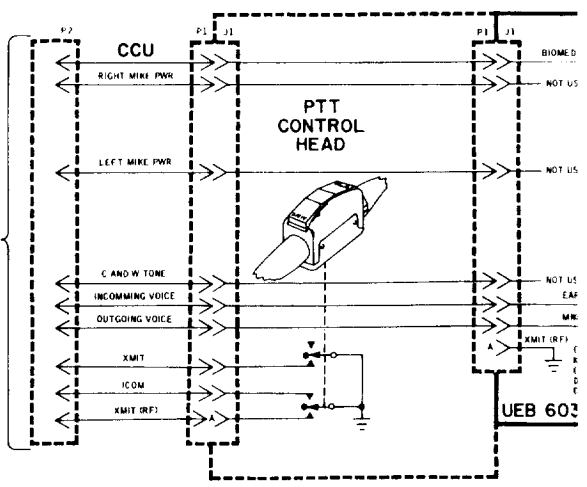

**EOLDOUT FRAME 1**



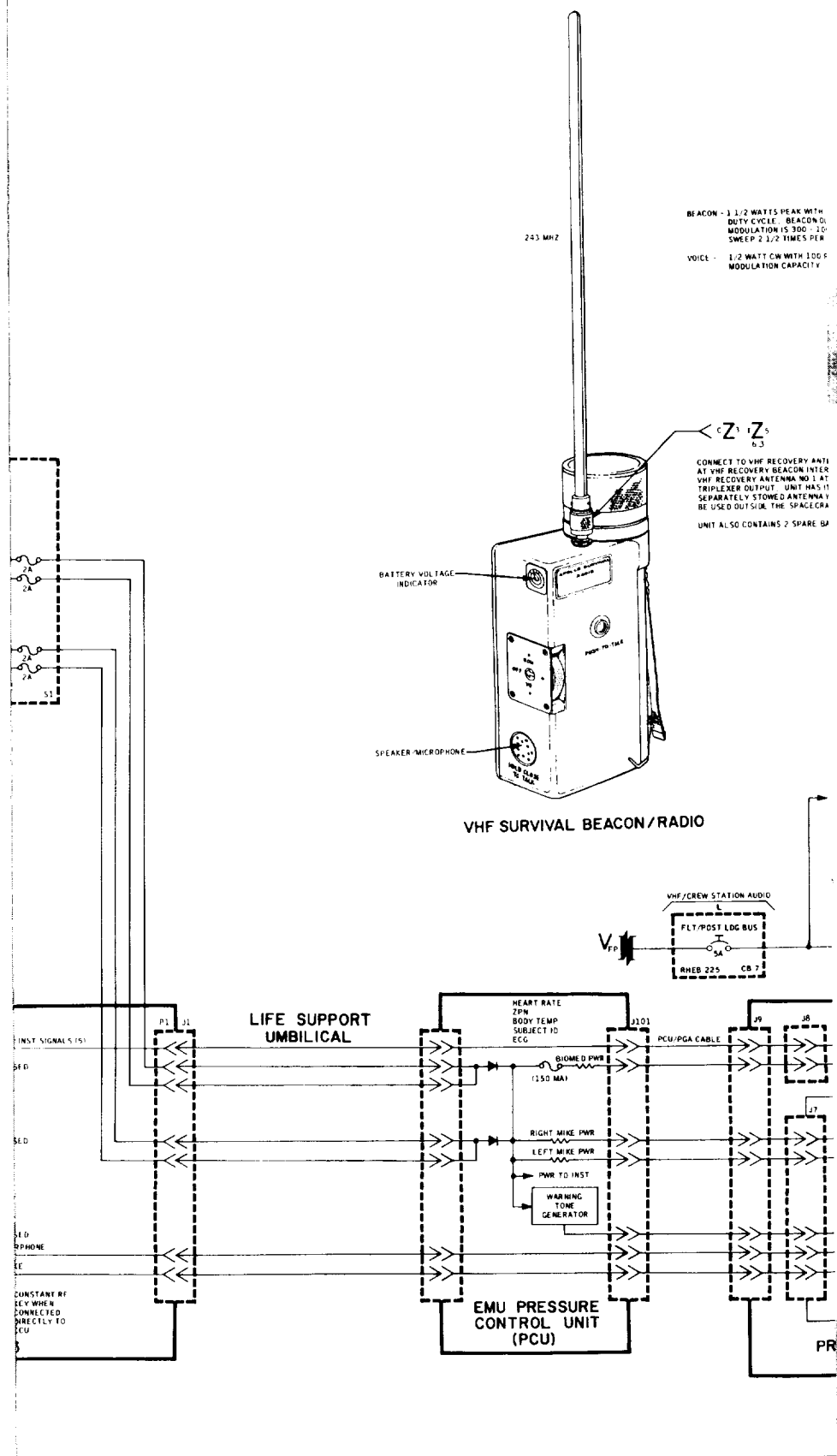

BEACON - 1 1/2 WATTS PEAK WITH DUTY CYCLE. BEACON MODULATION IS 300 Hz SWEEP 2 1/2 TIMES PER VOICE - 1.2 WATT CW WITH 100% MODULATION CAPACITY

CONNECT TO VHF RECOVERY ANTI AT VHF RECOVERY BEACON INTER VHF RECOVERY ANTENNA NO. 1 AT TRIPLEXER OUTPUT UNIT HAS IT SEPARATELY STOWED ANTENNA MAY BE USED OUTSIDE THE SPACECRA UNIT ALSO CONTAINS 2 SPARE BATT

VHF SURVIVAL BEACON/RADIO

LIFE SUPPORT UMBILICAL

EMU PRESSURE CONTROL UNIT (PCU)

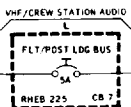

1000



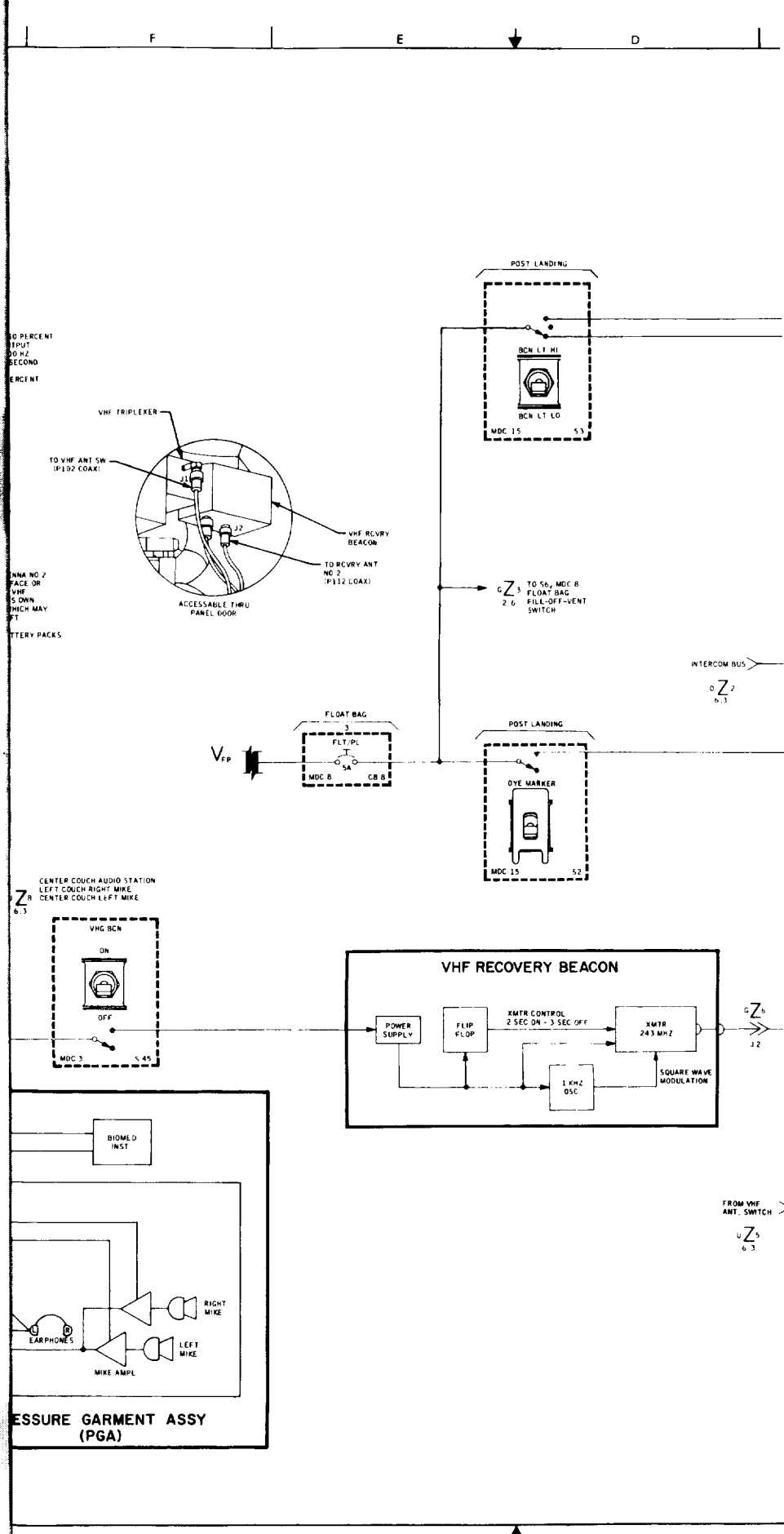

10 PERCENT  
INPUT  
50 HZ  
SECOND  
PERCENT

VHF TRIPLEXER

TO VHF ANT SW  
(P10X COAX)

VHF RCVRY  
BEACON

TO RCVRY ANT  
NO 2  
(P132 LOAX)

ACCESSIBLE THRU  
PANEL DOOR

INNA NO 2  
FACE OR  
VHF  
DOWN  
INCH MAY  
FT

BATTERY PACKS

Z  
R  
6.3

CENTER COUCH AUDIO STATION  
LEFT COUCH RIGHT MIKE  
CENTER COUCH LEFT MIKE

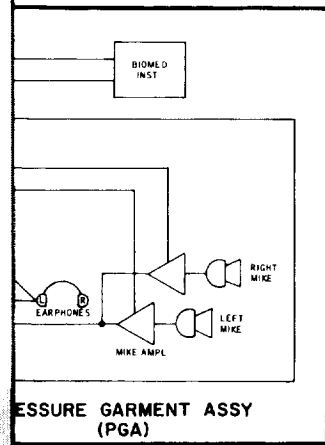

PRESSURE GARMENT ASSY  
(PGA)

INTERCOM BUS

GZ  
2  
6.3

FROM VHF  
ANT. SWITCH

GZ  
5  
6.3

1  
2  
3  
4  
5  
6  
7  
8  
9  
10  
11  
12  
13  
14  
15  
16  
17  
18  
19  
20  
21  
22  
23  
24  
25  
26  
27  
28  
29  
30  
31  
32  
33  
34  
35  
36  
37  
38  
39  
40  
41  
42  
43  
44  
45  
46  
47  
48  
49  
50  
51  
52  
53  
54  
55  
56  
57  
58  
59  
60  
61  
62  
63  
64  
65  
66  
67  
68  
69  
70  
71  
72  
73  
74  
75  
76  
77  
78  
79  
80  
81  
82  
83  
84  
85  
86  
87  
88  
89  
90  
91  
92  
93  
94  
95  
96  
97  
98  
99  
100

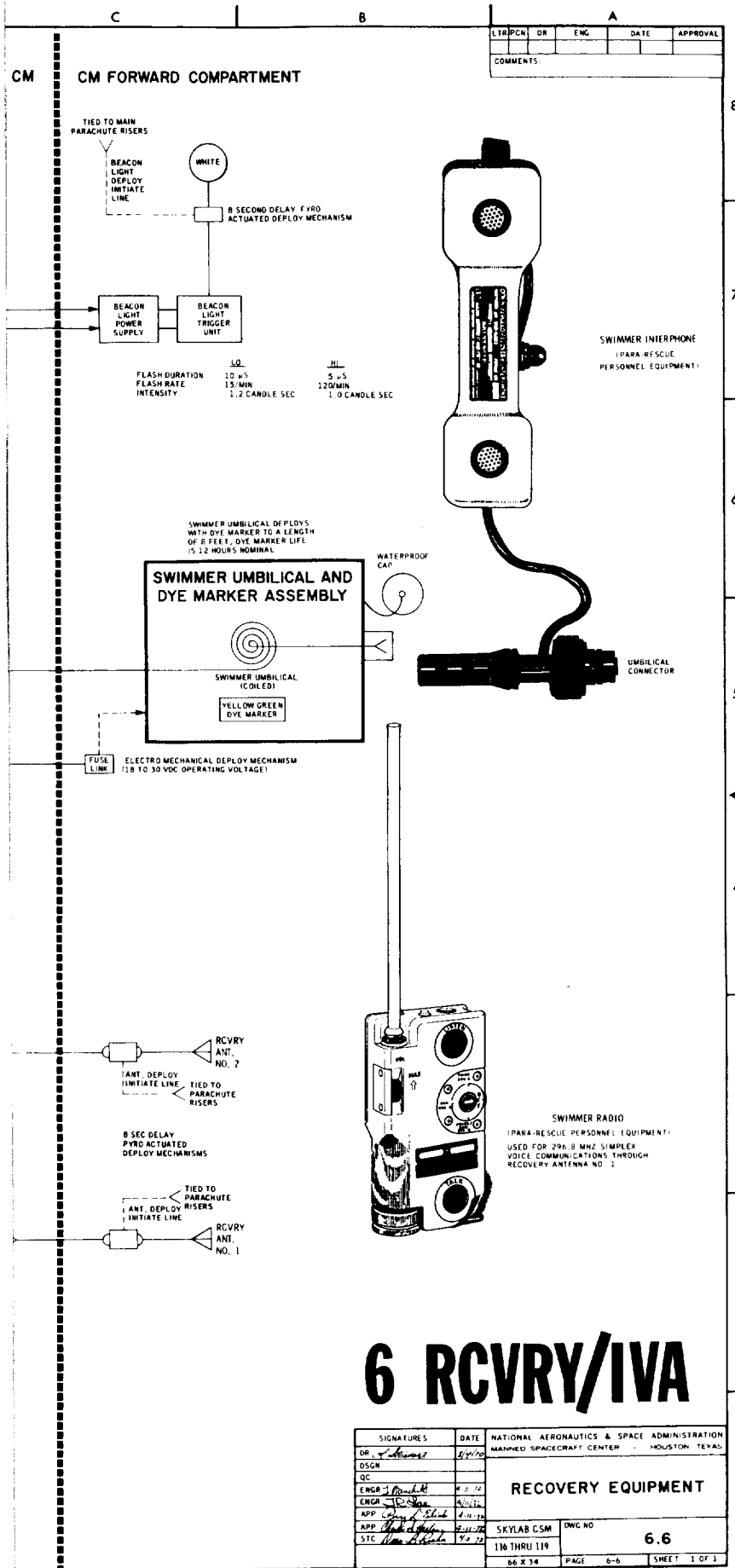

DATE	APPROVAL	ENG	DR	LT/PCN

COMMENTS

# 6 RCVRY/IVA

SIGNATURES		DATE	NATIONAL AERONAUTICS & SPACE ADMINISTRATION	
DR. <i>[Signature]</i>		7/21/72	MANNED SPACECRAFT CENTER - HOUSTON, TEXAS	
DSCN				
QC				
ENGR. <i>[Signature]</i>		8/10/72	<b>RECOVERY EQUIPMENT</b>	
ENGR. <i>[Signature]</i>		8/10/72		
APP. <i>[Signature]</i>		8/10/72		
APP. <i>[Signature]</i>		8/11/72	SKYLAB CSM	ENG NO.
STC. <i>[Signature]</i>		8/22/72	116 THRU 119	<b>6.6</b>
			66 X 34	PAGE 0-6
			SHEET 1 OF 1	

FOLDOUT FRAME 4



TABLE 6-I.- UNIFIED S-BAND TRANSPONDER AND FM TRANSMITTER

ITEM	FUNCTION and/or PARAMETERS
1. Weight	32 pounds
2. Cooling	ECS Primary and/or Secondary Glycol Loops
3. Electrical Power	
a. Dc Voltage	28 ± 4 Vdc (For control only)
b. Ac Voltage	115 Vac, 400 Hz, 3 phase
c. Power	
(1) PM Transponder	1.0 watts dc 16.5 watts dc (Prim or Sec)
(2) FM Transmitter	1.5 watts dc 6.7 watts ac
4. Activation Time	1 minute maximum - PM Receiver, PM Transmitter, and FM Transmitter
5. PM Receiver (Prim/Sec)	
a. Type	Double Conversion Superheterodyne, Phase Lock Loop
b. Frequency (Center)	2106.40625 MHz
c. Phase Lock Tracking Loop	
(1) In-Lock Range	±90 kHz for RF INPUT greater than -114 dBm and STATIC PHASE ERROR less than 15 degrees peak.
(2) In-Lock Rate	Linear rate of 35 kHz/second or less to ±90 kHz for RF INPUT greater than -114 dBm.
(3) Acquisition Probability	90 percent probability of acquisition on first sweep at above range and rates
(4) Predetection Noise Bandwidth	16 kHz
(5) Loop Noise Bandwidth (Optimizing Point)	800 Hz (0 dB S/N @ -134.5 dBm)
(6) Threshold	-125 dBm, defined as the level of unmodulated CW signal below which lock cannot be maintained for a period of at least one minute with 90 percent probability.

TABLE 6-I.- UNIFIED S-BAND TRANSPONDER AND FM TRANSMITTER - Continued

ITEM	FUNCTION and/or PARAMETERS
(7) Phase Error	24 degrees maximum (Offset + Rate Errors)
d. Dynamic Range	-51 dBm to -124 dBm (Normal) -35 dBm to -51 dBm (Must maintain lock and must not damage receiver).
e. Automatic Gain Control (AGC)	
(1) Attack Time	TBD
(2) Decay	3 seconds (-51 dBm to -127 dBm)
f. Ranging Channel	
(1) Modulation	PM on Carrier
(2) Bandwidth	10 kHz to 1.5 MHz (3 dB)
(3) PRN Bit Rate	992.834 kbs
(4) PRN Clock	992.834 kbs (496.417 kHz square wave)
(5) PRN Code Length	5,456,682 bits (lunar code)
g. High-Gain Antenna Track Channel	
(1) Pointing Error Signal	50 Hz amplitude modulated signal derived from the coherent AGC detector.
(2) Earth Presence Signal	DC signal superimpose on pointing error signal when RCVR is locked to incoming RF signal.
h. Outputs	(See Table 6-IV Modes)
6. PM Transmitter (Prim/Sec)	
a. Type	PM, S-band
b. Frequency	2287.5 MHz (Aux OSC Mode) or 240/221 times RCVR frequency when RCVR is phase locked to uplink RF signal. (See Auto OSC Control).
c. RF Output Power	301 to 374 milliwatts (Test Data)
d. Auto OSC Control	XMTR frequency is derived from XMTR Aux OSC prior to acquisition and RCVR VCO after acquisition. Switching is controlled using RCVR AGC signal.

TABLE 6-I.- UNIFIED S-BAND TRANSPONDER AND FM TRANSMITTER - Concluded

ITEM	FUNCTION and/or PARAMETERS
<ul style="list-style-type: none"> <li>(1) Aux OSC to RCVR VCO Switching Time</li> </ul>	Less than 0.25 seconds
<ul style="list-style-type: none"> <li>(2) RCVR VCO to Aux OSC Switching Time</li> </ul>	Less than 6 seconds (3 Seconds Nominal at -51 dBm)
<ul style="list-style-type: none"> <li>(3) Switching Threshold</li> </ul>	-127 dBm
<ul style="list-style-type: none"> <li>e. Inputs</li> </ul>	(See Table 6-III Modes)
7. FM Transmitter	
<ul style="list-style-type: none"> <li>a. Type</li> </ul>	FM, S-band
<ul style="list-style-type: none"> <li>b. Frequency</li> </ul>	2272.5 MHz $\pm$ 455 kHz
<ul style="list-style-type: none"> <li>c. Frequency Deviation</li> </ul>	$\pm$ 3 MHz maximum
<ul style="list-style-type: none"> <li>d. RF Output</li> </ul>	111 to 138 milliwatts (Test Data)
<ul style="list-style-type: none"> <li>e. Inputs</li> </ul>	(See Table 6-III Modes)
<ul style="list-style-type: none"> <li>(1) TV (dc coupled)</li> </ul>	$f_o$ at +1.3 Vdc Input $\Delta f/V = 1$ MHz/V Response dc to 500 kHz
<ul style="list-style-type: none"> <li>(2) Wideband (ac coupled)</li> </ul>	$\Delta f/V =$ MHz/V Response 200 Hz to 300 kHz
8. Special Operating Instructions	When switching between primary and secondary transponders, momentarily stop at the OFF (Center) position to allow control relays to operate.

TABLE 6-II.- S-BAND POWER AMPLIFIER

ITEM	FUNCTION and/or PARAMETERS
1. Weight	32 pounds maximum
2. Cooling	ECS Primary and/or Secondary Glycol Loop
3. Electrical Power	
a. Input Voltage	28 ± 4 Vdc control 115 Vac, 400 Hz, 3Ø
b. Input Power	
(1) Control Power	5 watts maximum steady state and 350 watts during switching for 0.5 seconds maximum.
(2) Ac Power	High Pwr Ampl Mode           81 watts Low Pwr Ampl Mode           32 watts Off/Bypass                    0 watts
	Sum ac power values to obtain simultaneous power level operation of Prim and Sec power amplifiers.
4. Power Amplification Activation Time	No RF amplification until 90 second nominal filament warm-up period complete.
	RF transfer (PM or FM) from one power amplifier to the other, with a 60 millisecond RF amplification dropout, is possible without an additional 90 second delay (filament warm-up) if the desired power ampli- fier is operating at the time of transfer.
5. RF Output	
a. PM Output - Prim or Sec Power Amplifier	High Pwr Mode:           11.2 watts min Low Pwr Mode:            2.8 watts min Bypass Mode:            Less than 2.5 dB below input
b. FM Output - Prim or Sec Power Amplifier	High Pwr Mode:           11.2 watts min



TABLE 6-II.- S-BAND POWER AMPLIFIER - Concluded

ITEM	FUNCTION and/or PARAMETERS
6. RF Input a. PM b. FM	275 to 400 milliwatts  100 to 145 milliwatts (For rated output)
7. Under Voltage Protection	Under-voltage protection circuit will remove ac pwr from power amplifier TWT if any phase of the ac input voltage falls below 95 Vac for 15 milliseconds or more. If this condition exists for 1 second or more, a 90 second filament warm-up delay will occur when ac voltage is restored.
8. Special Operating Instructions	Dc power should be applied before ac power and removed after ac power removal to prevent possible damage.



TABLE 6-III.- S-BAND DOWNLINK MODES AND MODULATION

PM DOWNLINK MODES AVAILABLE	MODE NUMBER	1	2	3	4	5	6	7	8	9
	Carrier Voice <sup>(a)</sup>	Carrier <sup>(a)</sup> Voice <sup>(a)</sup>	Carrier <sup>(a)</sup> Voice <sup>(a)</sup>	Carrier <sup>(a)</sup> Voice <sup>(a)</sup>	Carrier <sup>(a)</sup> Voice <sup>(a)</sup>	Carrier <sup>(a)</sup> Voice <sup>(a)</sup>	Carrier	Carrier	Carrier	Carrier
Channels Included	51.2-kbps TM	51.2-kbps TM	1.6-kbps TM	1.6-kbps TM	1.6-kbps TM	1.6-kbps TM	--	--	1.6-kbps TM	1.6-kbps TM
	--	PRN	PRN	--	--	--	--	PRN	--	PRN
	--	---	--	--	--	--	KEY	--	--	--
PM DOWNLINK MODULATION PROCESS	Modulation Schemes; Subcarrier Character- istics	PRN : PM directly on carrier (2287.5 MHz) Backup Voice : PM directly on carrier (2287.5 MHz) Normal Voice <sup>(a)</sup> : FM/PM; 1.25-MHz subcarrier deviated ±7.5 kHz peak (±9 kHz peak for voice and biomed) <sup>(c)</sup> TM : PCM/PSK/FM; 1.024 MHz subcarrier bi-phase modulated ±90° Key : AM/PM; 512 kHz, 100 percent AM								
	Peak Carrier Deviation- Radians (Δθ)	PRN : <sup>(c)</sup> Normal Voice <sup>(a)</sup> : 0.7 for Modes 1, 2 1.2 for Modes 3, 4, 11, 12 Backup Voice : 0.7 for Modes 8, 14 1.2 for Modes 10, 16 TM <sup>(c)</sup> : 1.2 for Modes 1, 2, 16 (51.2-kbps) and Mode 8 (1.6-kbps) 0.7 for Modes 3, 4 (1.6-kbps) 1.6 for Modes 5, 9 (1.6-kbps) and Modes 13, 15 (51.2-kbps) Key : 1.0								
FM DOWNLINK MODES AVAILABLE	MODE NUMBER	1	2	3	4	5	6	7	8	
	Channels Included	1:1 Playback of Recorded Voice, Re- corded CSM 51.2-kbps TM and Scien- tific Data <sup>(d)</sup>	32:1 Playback of Recorded Voice, Re- corded CSM 1.6-kbps TM and Scien- tific Data <sup>(d)</sup>	32:1 Playback of (CSM - Re- corded) LM 1.6-kbps TM	TV	Real-time Scientific <sup>(d)</sup>	Real-time 51.2-kbps TM <sup>(e)</sup> Real-time Scientific <sup>(d)</sup>	Real-time 1.6-kbps TM <sup>(e)</sup> Real-time Scientific <sup>(d)</sup>	1:1/32:1 back of tific Da Real-tim 51.2-kbps	
FM DOWNLINK MODULATION PROCESS	Modulation Schemes; Subcarrier Character- istics	TV : FM Directly on carrier (2272.5 MHz)      Playback LM TM : PCM/FM Playback Voice : FM Directly on carrier (2272.5 MHz)      Playback CSM TM <sup>(e)</sup> : PCM/PSK/FM; 1.024 MHz Scientific Data <sup>(d)</sup> : FM/FM (3 subcarriers) 95 kHz 125 kHz 165 kHz								
	Peak Carrier Deviation (Δf)	Playback Voice : 100 kHz +20 percent -40 percent Playback CSM TM <sup>(e)</sup> : 600 kHz ±15 percent Playback LM TM : 200 kHz +25 percent -50 percent TV : 1 MHz ±10 percent, f <sub>c</sub> at 1.3 Vdc within 0 to +455 kHz Scientific Data <sup>(d)</sup> : FM/FM (Real-time) 75 kHz ±15 percent 108 kHz ±15 percent 168 kHz ±15 percent								

- (a) Or voice and biomed
- (b) In the event of an EVA, the EVA biomed data is relayed via the CSM S-band link on the voice subcarrier; otherwise the biomed data comes back as PCM telemetry.
- (c) Varies with the received uplink.
- (d) Scientific data not used.
- (e) Auxiliary PMP mode will provide real time PCM with same USB-FM characteristics as playback PCM.
- (f) For Mode 10 Backup Voice Mod Index, place TLM bit rate switch to HIGH. Use LOW for Mode 14 Mod Index.
- (g) HBR Mod Index of 1.2 and 1.6 are actually 0.96 and 1.2 respectively due to HBR suppression of 1.024 MHz subcarrier.

FOLDOUT FRAME



	10	11	12	13	14	15	16	0
r	Carrier	Carrier	Carrier	Carrier	Carrier	Carrier	Carrier	
	Backup Voice (f)	Voice	Voice	--	Backup Voice (f)	--	Backup Voice	
s	--	--	--	51.2-kbps TM	--	51.2-kbps TM	51.2-kbps TM	No Carrier
	--	PRN	--	--	--	PRN	--	
	--	--	--	--	--	--	--	

--	--	--	--	--	--	--	--	--

--	--	--	--	--	--	--	--	--

	9	10	0
Play-Scienta and e s TM	1:1/32:1 Playback of Scientific Data and Real-time 1.6-kbps TM	8.1 Playback if (CSM-Recorded) LM 1.6-kbps TM	No Carrier

z subcarrier  
90°

(95 kHz SC)  
(125 kHz SC)  
(165 kHz SC)



\*

TABLE 6-IV.- S-BAND UPLINK MODES AND MODULATION PROCESS

PM UPLINK MODES AVAILABLE	MODE NUMBER	1	2	3	4	5	6	7	8	9	0	
	Channels Included	Carrier PRN -- --	Carrier -- Voice -- --	Carrier -- Voice -- Update	Carrier -- Voice -- Update	Carrier PRN -- Voice -- Update	Carrier PRN -- Voice -- Update	Carrier PRN -- Voice -- Update	Carrier -- Voice -- Update	Carrier PRN Backup Voice -- --	Carrier -- -- -- --	-- -- -- --
PM UPLINK MODULATION PROCESS	Modulation Schemes: Subcarrier Character- istics	PRN : PM directly on carrier Voice : FM/FM; 30-kHz subcarrier deviated $\pm 7.5$ kHz (peak) Update : PSK/FM/FM; 70-kHz subcarrier deviated $\pm 5.0$ kHz (peak) Backup Voice: FM/FM; 70-kHz subcarrier deviated $\pm 5.0$ kHz (peak)										
		MODE NUMBER	1	2	3	4	5	6	7	8	9	0
	Carrier Phase Deviation (Radians- Peak)*	PRN Voice Update Backup Voice	1.34 -- -- --	-- 1.85 -- --	-- -- 1.85 --	0.38, 1.20 -- --	0.38 -- 1.20 --	0.44 1.00 1.00 --	-- 1.10 1.10 --	0.38 -- -- 1.20	NA	NA

\*All phase deviations have  $\pm 10\%$  tolerance

TABLE 6-V.- PREMODULATION PROCESSOR

ITEM	FUNCTION and/or PARAMETERS
1. Weight	14.5 pounds
2. Cooling	ECS Primary and/or Secondary Glycol Loops
3. Electrical Power	
a. Input Voltage	28 ± 4 Vdc
b. Input Power	8.5 watts
4. CM Down Voice Channel (Normal)	
a. Subcarrier	1.25 MHz derived from CTE 512 kHz.
b. Response	300 to 3000 Hz flat within 6 dB.
5. CM Down Voice Channel (Backup)	
a. Response	300 to 2300 Hz flat within 6 dB.
6. LM/EVA Voice and LM Biomed Relay Channel	
a. Subcarrier	1.25 MHz derived from CTE 512 kHz.
b. Subcarrier Deviation	LM Voice - 8 kHz EVA Voice and Biomed - 9 kHz
c. Response	300 to 13,000 Hz flat within 2 dB.
d. LM Input	Voice
e. EVA Input	Voice and/or 7 Biomed Subcarriers
	4.0 kHz ± 5% f <sub>o</sub>
	5.4 kHz ± 5% f <sub>o</sub>
	6.8 kHz ± 5% f <sub>o</sub>
	8.2 kHz ± 5% f <sub>o</sub>
	9.6 kHz ± 4% f <sub>o</sub>
	11.0 kHz ± 3% f <sub>o</sub>
	12.4 kHz ± 3% f <sub>o</sub>
7. Tape Recorder Output - LM & CSM Voice	LM and CSM intercom voice are mixed and output to DSE for recording.
a. Response	300 to 2300 Hz flat within 2 dB.
8. LM PCM Output Channel	
a. Response	LM PCM (1.6 kbs) is limited and output to DSE for recording.
	600 to 2800 Hz flat within 1 dB.



TABLE 6-V.- PREMODULATION PROCESSOR - Continued

ITEM	FUNCTION and/or PARAMETERS
9. CM PCM Data Channel (Real-time and Playback) a. Input b. Subcarrier c. Modulation	51.2 kbs or 1.6 kbs NRZ PCM data.  1.024 MHz derived from PCM 512 kHz ref signal.  Bi-phase
10. Scientific Data Channel (Real-Time) a. Response  b. Frequency and Deviation	Flat within 2 dB  <u>Channel</u> 1    0 to 2850 Hz 2    0 to 3750 Hz 3    0 to 4950 Hz  <u>Channel</u> 1    95 kHz +7.5% $f_o$ 2    125 kHz +7.5% $f_o$ 3    165 kHz +7.5% $f_o$
11. Scientific Data Channel (Playback) a. Response	Flat within 2 dB  <u>Channel</u> <u>32:1 Playback</u> <u>1:1 Playback</u> 1    12.5 to 89 Hz   50 to 2850 Hz 2    12.5 to 117 Hz   50 to 3750 Hz 3    12.5 to 154 Hz   50 to 4950 Hz
12. Tape Recorder Input - LM PCM Channel a. Response	(Recorded data bandwidths)  15 to 90 kHz flat within 1 dB.
13. Uplink Subcarrier Detectors a. Up Voice  b. Updata c. Response	30 kHz (normal) 70 kHz (backup)  70 kHz  300 to 4,000 kHz flat within 3 dB.

TABLE 6-V.- PREMODULATION PROCESSOR - Concluded

ITEM	FUNCTION and/or PARAMETERS										
14. Emergency Key Control	512 kHz signal derived from CTE 512 kHz timing signal baseband modulates S-band PM carrier when key is depressed. A 400 Hz sidetone output to the audio center is provided when key is depressed.										
15. Data Rate Indicator Control	Dc signal from PCM to control modulation levels to PM and FM Modulator modules.  HBR = 5.3 Vdc LBR = 0 Vdc										
16. Television Channel a. Direct Output b. Response c. Isolated Output d. Response	To S-band FM transmitter  Dc to 500 kHz flat within 0.5 dB.  To GSE hardline  10 to 500,000 Hz flat within 3 dB.										
17. Uplink Voice Squelch (30 kHz Discriminator Output) a. Operation	Transistor switch actuated by voice subcarrier threshold detector. Switch grounds input to voice output amplifier.										
b. Threshold	<table border="1"> <thead> <tr> <th data-bbox="808 1178 948 1205"><u>Mode</u></th> <th data-bbox="948 1178 1279 1205"><u>Received Carrier Power</u></th> </tr> </thead> <tbody> <tr> <td data-bbox="808 1220 834 1247">2</td> <td data-bbox="1029 1220 1149 1247">-119 dBm</td> </tr> <tr> <td data-bbox="808 1262 834 1289">4</td> <td data-bbox="1029 1262 1149 1289">-111 dBm</td> </tr> <tr> <td data-bbox="808 1304 834 1331">6</td> <td data-bbox="1029 1304 1149 1331">-108 dBm</td> </tr> <tr> <td data-bbox="808 1346 834 1373">7</td> <td data-bbox="1029 1346 1149 1373">-109 dBm</td> </tr> </tbody> </table>	<u>Mode</u>	<u>Received Carrier Power</u>	2	-119 dBm	4	-111 dBm	6	-108 dBm	7	-109 dBm
<u>Mode</u>	<u>Received Carrier Power</u>										
2	-119 dBm										
4	-111 dBm										
6	-108 dBm										
7	-109 dBm										
c. Squelch Level	Greater than 35 dB squelch of audio output when threshold is reached.										

TABLE 6-VI.- VHF AM TRANSCEIVER EQUIPMENT

ITEM	FUNCTION and/or PARAMETERS
1. Weight	13 pounds maximum
2. Cooling	ECS Primary and/or Secondary Glycol Loop
3. Electrical Power	28 ± 4 Vdc
a. Input Voltage	Duplex A (Key OFF)      4.2 watts
b. Input Power	Duplex A (Key ON)      28.8 watts
	Simplex A (Key OFF)    4.1 watts
	Simplex A (Key ON)     28.8 watts
	Duplex B (Key OFF)     3.8 watts
	Duplex B (Key ON)     27.6 watts
	Simplex B (Key OFF)    4.0 watts
	Simplex B (Key ON)    27.6 watts
	RCV A Only              1.2 watts
	RCV B Only              1.2 watts
	PTT (Key ON)            1.3 watts
4. Transmitter (A or B)	
a. Activation Time	250 milliseconds maximum to reach standby condition.
	20 milliseconds maximum to reach full transmit power from PTT (Key ON)
b. RF Output	5 dBW (average) minimum
c. Transmitter Frequency	XMTR A 296.8 MHz ± 8.90 kHz
	XMTR B 259.7 MHz ± 7.79 kHz
d. Modulation	Modulated by clipped speech between 300 and 2000 Hz combined with a 30 kHz signal such that the ON-OFF duty cycle of the RF carrier (50 ± 5 percent) is speech signal dependent and the ON-OFF period is 30 kHz. When XMTR is keyed ON with no speech input the average RF Output is 5 dBW minimum.

TABLE 6-VI.- VHF AM TRANSCEIVER EQUIPMENT - Concluded

ITEM	FUNCTION and/or PARAMETERS
5. Receiver (A or B) <ul style="list-style-type: none"> <li>a. Activation Time</li> <li>b. RCVR RF Input</li> <li>c. A&amp;B Output Response               <ul style="list-style-type: none"> <li>(1) Output to Audio Center (Voice)</li> <li>(2) Output to PMP (Voice and Biomed Data)</li> </ul> </li> <li>d. RCVR B LM PCM Output</li> <li>e. RCVR Squelch</li> </ul>	500 milliseconds maximum to reach full receive operation from turn-on.  100 milliseconds maximum to reach full receive operation from PTT release (Key OFF)  2 to 625,000 microvolts  300 to 3000 Hz, + 2 dB - 3 dB maximum variation, down 12 dB minimum at 5000 Hz.  300 to 13,000 (2 dB).  300 to 13,000 Hz (2 dB).  Adjustable by MDC 2 controls for between 0 and 10 to 25 microvolts. 9 on squelch control is maximum squelch (10 to 25 microvolt level)
6. VHF Digital Ranging Generator Interface <ul style="list-style-type: none"> <li>a. RCVR A Gate Input</li> <li>b. RCVR A Tone Output</li> <li>c. XMTR B Tone Input</li> <li>d. XMTR B Quieting (SC Inhibit)</li> </ul>	5.266 kHz early-late gate signal to gate fine tone error signal through RCVR IF AMPLS.  RCVR A detected IF amplifier output to digital ranging generator.  Coarse and module 2 sum of coarse and medium tone input during acquisition and fine tone input during range tracking.  Inhibit to XMTR 30 kHz quieting OSC during fine tone transmissions.

TABLE 6-VII.- AUDIO CENTER EQUIPMENT

ITEM	FUNCTION and/or PARAMETERS
1. Weight	7.9 pounds
2. Cooling	ECS Primary and/or Secondary Glycol Loop
3. Electrical Power	
a. Input Voltage	28 ± 4 Vdc
b. Input Power	14.2 watts (3 Stations ON)
4. Stations	Left Couch Station Right Couch Station Center Couch Station
5. Microphone Amplifier	
(1 Each Station)	
a. Input	0 dBm sound pressure level (nominal)
b. Response	300 to 3000 Hz flat within 2 dB
c. Automatic Volume Control	
(1) Range	Less than 4 dB change for 20 dB input change
(2) Attack Time	50 milliseconds
(3) Release Time	1 to 6 seconds
(4) Threshold	13 ± 3 dB (referred to input)
d. Output	0 dBm ± 3 dB at threshold
e. Isolation	30 dB or greater between modulation output channels
6. Earphone Amplifier	
(1 Each Station)	
a. Input	Variable over 35 dB range of given input signal
b. Output	With 13 dB on input attenuator the output is 20 dBm ± 3 dBm
c. Response	300 to 3000 Hz flat within 2 dB
d. Isolation	40 dB or greater between input channels

TABLE 6-VII.- AUDIO CENTER EQUIPMENT - Concluded

ITEM	FUNCTION and/or PARAMETERS
7. Voice Operated Relay (VOX) a. VOX Sensitivity b. VOX Attack c. VOX Release	Adjustable for input from -10 dBm to +10 dBm Less than 50 milliseconds 2 ± 0.7 seconds
8. Intercom Bus a. GSE Output b. Swimmer Output c. Tape Recorder	(Not Used) For recovery voice to recovery swimmers Output for voice recording on DSE
9. Spacecraft/GSE Facility Hardline Voice Interface	The Pad COMM Switch and Volume Control are used to operate each audio station's input/output voice links with the checkout and launch facilities.

TABLE 6-VIII.- UPDATA LINK EQUIPMENT

ITEM	FUNCTION and/or PARAMETERS
1. Weight	21 pounds maximum
2. Cooling	ECS Primary and/or Secondary Glycol Loops
3. Electrical Power	
a. Input Voltage	28 + 2, -4 Vdc
b. Input Power	8.9 watts maximum
4. Information Signal	
a. Modulation	Phase shift key FM modulation of 70 kHz S-band Uplink subcarrier. Modulation deviation is $\pm 5$ kHz.
b. Sub-bit "One"	Sub-bit "one" begins when the positive transition of the 1 kHz information signal cross each other in-phase.
c. Sub-bit "Zero"	Sub-bit "zero" begins when the positive transition of the 1 kHz sync signal crosses the 2 kHz information signal 180 degrees out-of-phase.
d. Sub-bit Period	One millisecond.
e. Sub-bit Rate	1,000 bits per second.
5. Message Structure	
a. Sub-bit Code	5 sub-bits per information bit. Vehicle address sub-bit code is different than system address and data word. Sub-bit coding (see Drawing 6.5).
b. Message Code	Each message contains up to 30 information bits which consist of a vehicle address, system address, and data word (see Drawing 6.5).
(1) Vehicle Address	Eight possible codes selectable by hard wire on an external connector.

TABLE 6-VIII.- UPDATA LINK EQUIPMENT - Continued

ITEM	FUNCTION and/or PARAMETERS
(2) System Address	<ol style="list-style-type: none"> <li>1. Command Module Computer</li> <li>2. Real-Time Command (Internal relays)</li> <li>3. Real-Time Command (External relays) (not used)</li> <li>4. Central Timing Equipment</li> <li>5. Salvo RTC reset</li> <li>6. Test message A &amp; B</li> <li>7. Auxiliary decoder (not used)</li> </ol>
(3) Data Word	(See Drawing 6.5.)
6. Sub-bit Detector	The 1 kHz and 2 kHz PSK signals are separated to provide synchronization and sub-bit data.
a. Sub-bit Sync	Recovered by phase lock techniques. Three 5 sub-bit sequences must precede a command message to synchronize the UDL.
b. Sub-bit Data	Detected at a 1 kHz rate.
7. Decoder Operation	The vehicle address decoded as "access" bits are decoded asynchronously (without sync). Message timing in the decoder is not established until after vehicle address is decoded.
	Vehicle address recognition disables access bit decoding and enables the decoding of the remaining message.
	The system address determines information for receiving the correct number of info bits and processing a particular data word.
	After the proper number of bits have been received and temporarily stored in the main register, the program control modifies the operation to enable processing or transfer of the data word.



TABLE 6-VIII.- UPDATA LINK EQUIPMENT - Concluded

ITEM	FUNCTION and/or PARAMETERS																																		
<p>8. Verification Signal</p>	<p>When a complete message is received, processed or transferred without the detection of sub-bit or bit errors and without the occurrence of a logic power deviation, the parallel 4-bit verification code to the PCM TM will be as follows:</p> <table border="1" data-bbox="885 657 1365 846"> <thead> <tr> <th>PCM BIT</th> <th>B1</th> <th>B2</th> <th>B3</th> <th>B4</th> </tr> </thead> <tbody> <tr> <td>UDL OFF</td> <td>0</td> <td>0</td> <td>0</td> <td>0</td> </tr> <tr> <td>*TEST A</td> <td>0</td> <td>1</td> <td>1</td> <td>0</td> </tr> <tr> <td>*TEST B</td> <td>1</td> <td>0</td> <td>0</td> <td>1</td> </tr> <tr> <td>*SYS VAL</td> <td>0</td> <td>1</td> <td>0</td> <td>1</td> </tr> <tr> <td>UDL STANDBY (ON)</td> <td>1</td> <td>0</td> <td>1</td> <td>0</td> </tr> </tbody> </table> <p>*Verification signal is presented to the PCM as follows:</p> <table border="1" data-bbox="943 936 1333 993"> <tbody> <tr> <td>PCM HBR</td> <td>55 milliseconds</td> </tr> <tr> <td>PCM LBR</td> <td>250 milliseconds</td> </tr> </tbody> </table>	PCM BIT	B1	B2	B3	B4	UDL OFF	0	0	0	0	*TEST A	0	1	1	0	*TEST B	1	0	0	1	*SYS VAL	0	1	0	1	UDL STANDBY (ON)	1	0	1	0	PCM HBR	55 milliseconds	PCM LBR	250 milliseconds
PCM BIT	B1	B2	B3	B4																															
UDL OFF	0	0	0	0																															
*TEST A	0	1	1	0																															
*TEST B	1	0	0	1																															
*SYS VAL	0	1	0	1																															
UDL STANDBY (ON)	1	0	1	0																															
PCM HBR	55 milliseconds																																		
PCM LBR	250 milliseconds																																		
<p>9. Internal Relays</p> <p>a. Type</p> <p>b. Rating</p> <p>c. Actuation Time</p> <p>d. Dc current</p> <p>e. Latch-in Current</p>	<p>32 double-pole double-throw relays, magnetic latching</p> <p>2 ampere, minimum, contact rating</p> <p>Opening or closure less than 5 milliseconds.</p> <p>18.7 milliamperes per relay</p> <p>7.1 milliamperes per relay</p>																																		

TABLE 6-IX.- VHF RECOVERY BEACON

ITEM	FUNCTION and/or PARAMETERS
1. Weight	2.7 pounds maximum
2. Cooling	Not required
3. Electrical Power	
a. Input Voltage	28 ± 4 Vdc
b. Input Power	6.9 watts maximum average over interruption cycle
4. RF Output Power	3 watts minimum during the ON time of the interruption cycle
5. XMT Frequency	243 ± 0.0126S MHz
6. Modulation	Carrier is amplitude - modulated by 1 kHz square wave, 20 to 40 percent.
7. Interruption Cycle	Modulated carrier is present at the output for 2 seconds and absent for 3 seconds.

TABLE 6-X.- VHF SURVIVAL BEACON - TRANSCEIVER

ITEM	FUNCTION and/or PARAMETERS
1. Weight	5 pounds maximum including battery pack
2. Cooling	Not required
3. Electrical	
a. Dc Voltage	16.2 Vdc from self-contained battery
b. Power	Battery pack life 24 hours in 100% beacon operation
4. Activation Time	No appreciable warm-up period
5. Receiver	
a. Type	Portable, VHF AM Beacon - transceiver with integral microphone, speaker, PTT pushbutton battery, antenna, and test meter
b. Frequency	243 MHz
Sensitivity ( $\frac{S + N}{N} = 10 \text{ dB}$ )	-97 dBm minimum
6. Transmitter	
a. Frequency	243 MHz
b. RF Output	
(1) Beacon	1.25 watts (peak)
(2) Voice	0.5 watts minimum (unmodulated)
c. Modulation	
(1) Beacon	ON-OFF key by a swept square wave, which varies in frequency from 1000 Hz to 300 Hz at a sweep rate of 2.5 Hz
(2) Voice	
7. Antenna	1/4 wavelength flexible whip

TABLE 6-XI.- ANTENNA SWITCH, S-BAND

ITEM	FUNCTION and/or PARAMETERS
1. Weight	2.5 pounds
2. Cooling	Not required
3. Electrical Power	
a. Input Voltage	23 to 30 Vdc
b. Input Power	12 watts (For omni position)
4. Actuation Time	150 milliseconds maximum
5. Mechanics	Non-latching, 5-position, break-before-make
6. Isolation	40 dB minimum between RF lines

TABLE 6-XII.- ANTENNA SWITCH, VHF

ITEM	FUNCTION and/or PARAMETERS
1. Weight	0.75 pounds maximum
2. Cooling	Not required
3. Electrical Power	
a. Input Voltage	None - manual switch
b. Input Power	None - manual switch
4. Actuation Time	Not applicable
5. Mechanics	Manual, 3-position, make-before-break
6. Isolation	40 dB minimum between RF lines

TABLE 6-XIII.- ANTENNA, S-BAND OMNI

ITEM	FUNCTION and/or PARAMETERS								
1. Type	Helix in loaded cavity								
2. Frequency	2100 MHz to 2300 MHz								
3. Gain	Greater than -3 dB relative to isotropic source between $\theta > 45^\circ$ and $\theta > 145^\circ$ (See Item 5 below.)								
4. Polarization	Right-hand circular								
5. Coverage	The following coverage is applicable with sequential selection of the four antennas:								
	<table border="0"> <thead> <tr> <th data-bbox="802 793 878 821"><u>*GAIN</u></th> <th data-bbox="1003 793 1170 821"><u>SOLID ANGLE</u></th> </tr> </thead> <tbody> <tr> <td data-bbox="802 835 878 863">≥ -3 dB</td> <td data-bbox="889 835 1284 863">between <math>\theta = 45^\circ</math> and <math>145^\circ</math></td> </tr> <tr> <td data-bbox="802 863 878 890">≥ -20 dB</td> <td data-bbox="889 863 1284 890">between <math>\theta = 15^\circ</math> and <math>165^\circ</math></td> </tr> <tr> <td data-bbox="802 890 878 917">≥ -24 dB</td> <td data-bbox="889 890 1284 917">between <math>\theta = 10^\circ</math> and <math>170^\circ</math></td> </tr> </tbody> </table>	<u>*GAIN</u>	<u>SOLID ANGLE</u>	≥ -3 dB	between $\theta = 45^\circ$ and $145^\circ$	≥ -20 dB	between $\theta = 15^\circ$ and $165^\circ$	≥ -24 dB	between $\theta = 10^\circ$ and $170^\circ$
<u>*GAIN</u>	<u>SOLID ANGLE</u>								
≥ -3 dB	between $\theta = 45^\circ$ and $145^\circ$								
≥ -20 dB	between $\theta = 15^\circ$ and $165^\circ$								
≥ -24 dB	between $\theta = 10^\circ$ and $170^\circ$								
	GAIN WILL BE LESS THAN -24 dB for cones, with solid angles of 20 degrees at the spacecraft nose and SPS nozzle.								
	*Applicable for $\phi = 0^\circ$ to $360^\circ$								
6. Power Rating	15 watts of CW RF								

TABLE 6-XIV.- ANTENNA, VHF SCIMITAR

ITEM	FUNCTION and/or PARAMETERS
1. Type	Scimitar blade - one inch thick cover for thermal protection
2. Frequency	225 MHz to 450 MHz
3. Gain	Greater than -3 dB (on axis) relative to isotropic source.
4. Polarization	Slant linear
5. Coverage	Each antenna covers a hemisphere, approximately full coverage obtainable with antenna selection.
6. Power Rating	50 watts average

TABLE 6-XV.- VHF RECOVERY

ITEM	FUNCTION and/or PARAMETERS
1. Type	10-inch erectible tape with ground-plane whiskers
2. Frequency	243 MHz tuned
3. Gain	+6 dB with respect to isotropic source, -18 dB null
4. Polarization	Vertical
5. Coverage	±70 degree elevation 360 degree azimuth
6. Power Rating	50 watts continuous



TABLE 6-XVI.- VHF DIGITAL RANGING GENERATOR

ITEM	FUNCTION and/or PARAMETERS
1. Weight	7 pounds maximum
2. Cooling	ECS Primary and/or Secondary Glycol Loop
3. Electrical Power	
a. Input Voltage	28 ± 4 Vdc
b. Input Power	10 watts maximum
4. Ranging Accuracy	±450 feet maximum error at 500 feet for ranging system: ±180 ft random ±270 ft bias
5. Range Tones	247 Hz (coarse), 3.9 kHz (medium), 31.6 kHz (fine)
6. EMS Interface	
a. Range Data Signal	Serial pulse train output to count up EMS range display to desired range in 0.01 n.mi. (60.761 feet) increments.
b. Maximum Unambiguous Range	327.68 n.mi. for intial range display.
c. Countdown Command Signal	When range is decreasing, a countdown command precedes each range data pulse.
d. Reset Pulse Signal	Resets EMS range display to zero when:
	a. Data good test fails
	b. Reacquisition sequence is initiated.
	c. Range rate is greater than 1,800 feet/second.
7. CMC Interface	
a. Range Data Signal	15-bit serial word with the "1" and "0" bits provided as pulse outputs on separate lines, most significant bit first.
b. Command Readout Input	3.2 kilobit/second Pulse train from CMC to clock out the range data signal
c. Range Strobe Input	3.2 kilobit/second pulse train from CMC to provide internal timing for loading range data into range data register.

TABLE 6-XVI.- VHF DIGITAL RANGING GENERATOR - Concluded

ITEM	FUNCTION and/or PARAMETERS
<p>d. Data Good Signal</p> <p>8. Data Good Test</p>	<p>A data good test is initiated by the range strobe input just prior to loading the range data register and prior to permitting the output register to be clocked out to the CMC. Absence of the data good signal for two successive tests will result in a CMC alarm.</p> <p>Data good test is performed only during the following periods:</p> <ul style="list-style-type: none"> <li>a. Range reacquisition sequence (initiated by VHF ranging reset switch)</li> <li>b. CMC range strobe sequence</li> </ul> <p>Data good test will fail under the following conditions:</p> <ul style="list-style-type: none"> <li>a. Fine tracker loses lock during fine tone tracking.</li> <li>b. Range rate of greater than 1800 feet/second</li> <li>c. Coarse tone tracker is locked to an ambiguous null. This condition is corrected by the internal logic which forces the tracker to reacquire during acquisition.</li> </ul>

TABLE 6-XVII.- COLOR TELEVISION CAMERA

ITEM	FUNCTION and/or PARAMETERS
1. Weight	Camera 11.0 pounds Lens 1.3 pounds
2. Cooling	Not required
3. Electrical Power	
a. Input Voltage	28 Vdc
b. Input Power	23 watts (camera) 2.5 watts (monitor)
4. Activation time	Instant on
5. Resolution	200 TV lines-per-picture height
6. Scanning rate	
a. Lines	525 scan lines per frame (2:1 interlace)
b. Frames	30 frames per second
7. Video Bandwidth	2 MHz
8. Illumination Levels	5 to 12,000 foot-candles by using f-stops. (20 watt flourescent lamp $\approx$ 4870 foot-candles.)
9. Aspect Ratio	4:3
10. Optics	<u>Field of View</u> <u>Near Object Distance</u>
a. Zoom Lens (6:1)	7 degrees      Focused 24 in. to $\infty$ 43 degrees      Focused 20 in. to $\infty$
b. f-stops	4.4 to 44 continuously variable
c. Focal Length	25 to 150 mm
11. Video Output	3.5 volts peak-to-peak, dark negative, bandpass 4.5 MHz
12. Connectors	One video, one power
13. Automatic Light Control Switch	
a. Peak	(Bright object in scene)
b. Average	(Uniform scene lighting) 1000:1 light range with AGC
14. Monitor	The monitor provides crew viewing of actual camera picture transmitted so that f-stop, light level, zoom position and focus can be properly accomplished.
15. Video Control Switch	
a. Transmit	Normal video output
b. Standby	Picture content of video is inhibited

TABLE 6-XVIII.- DATA STORAGE EQUIPMENT (DSE)

ITEM	FUNCTION and/or PARAMETERS
1. Weight	42.5 pounds
2. Cooling	ECS primary glycol loop
3. Electrical	
a. DC Voltage	28 ± 4 Vdc
b. AC Voltage	115 Vac, 400 Hz, 3-phase
c. Total Power Consumption	50 watts
4. Operational Stability	
a. Record Speed	3 seconds (max) from activation
b. Playback Speed	5 seconds (max) from activation
c. Tape Speed	±0.5% of specification with a 400 Hz absolute power frequency
d. Wow and Flutter	
(1) 15 ips Record and Playback	3% peak-to-peak (max) with no vibration present; flutter bandwidth is from 0.1 to 5,000 Hz
(2) 3.75 ips Record and 120 ips Playback	1.5% peak-to-peak (max) with no vibration present; flutter bandwidth is from 0.1 to 5,000 Hz
5. Record/Playback Tracks	14 tracks (total)
a. CM PCM Data	4 tracks
b. CM PCM Data Timing	1 track
c. LM PCM Data	1 track (not used)
d. CM-VHF Received Voice	1 track
e. Analog Data	7 tracks (not used)
6. CM PCM Data Channel	
a. Data	1.6 or 51.2 kbps NRZ
b. Timing Signal	1.6 or 51.2 kHz symmetrical squarewave
c. Playback Speed	
(1) 1.6 kbps Data	120 ips (51.2 kbps)
(2) 51.2 kbps Data	15 ips (51.2 kbps)

TABLE 6-XVIII.- DATA STORAGE EQUIPMENT (DSE) - Continued

ITEM	FUNCTION and/or PARAMETERS
d. Record Speed (1) 1.6 kbps Data (2) 51.2 kbps Data	3.75 ips 15 ips
7. LM PCM Data Channel a. Data b. Record/Playback Speed	1.6 kbps Manchester Code Determined automatically by CM PCM data record/playback speed
8. CM-VHF Received Voice Channel a. Signal b. Record/Playback Speed	300 to 2,500 Hz Determined automatically by CM PCM data record/playback speed
9. Analog Channels a. Frequency Response (1) 15 ips Record and 15 ips Playback (2) 3.75 ips Record and 120 ips Playback b. Harmonic Distortion c. Signal-to-Noise ratio (Input-to-Output) d. Crosstalk	4 dB (50 Hz to 10,000 Hz) 6 dB (50 Hz to 25,000 Hz) 4 dB (12.5 Hz to 2,500 Hz) 6 dB (12.5 Hz to 6.250 Hz) Less than 2 percent 35 dB (min) at 1,000 Hz 30 dB (min) at 32,000 Hz Down 32 dB (min) at 1,000 Hz for 15 ips playback Down 23 dB (min) at 32,000 Hz for 120 ips playback
10. Tape Motion Sensor	Indicates tape motion forward or backward
11. Tape Speed Sensor	Senses playback bit rate and automatically switches transport to proper speed. Playback speed is 120 ips if sensor fails.  Sensor is overridden if in LM PCM playback mode or playback electronics is off. Speed will be 120 ips forward or backward.

TABLE 6-XVIII.- DATA STORAGE EQUIPMENT (DSE) - Concluded

ITEM		FUNCTION and/or PARAMETERS				
12. Tape Recorder Mode:						
Data Source	Record			Playback		
	Speed	Control	Data <sup>②</sup>	Speed	Control	Data <sup>②</sup>
CSM	3.75 ips	Bit Rate Select Switch	Voice 1.6 kbps Analog data	120 ips (32:1)	Auto Speed Select	Voice 51.2 kbps Analog data
	----- 15 ips		Voice 51.2 kbps Analog data	----- 15 ips (1:1)		Voice 51.2 kbps Analog data
IM <sup>①</sup> (VHF)	3.75 ips	Bit Rate Select Switch	1.6 kbps	120 ips	(Disconnected)	51.2 kbps
	----- 15 ips					12.8 kbps

NOTES: ① Not used on Skylab CSM  
② Analog data channels not used

)

)

)

)

)

7 INSTRU-  
MENTATION

)

)

)

)

)

|



8 GUIDANCE AND  
CONTROL  
SYSTEM

)

)

)

)

)

|

)

)

)

)

)

9 SERVICE  
PROPULSION  
SYSTEM

)

)

)

)

)

|

)

)

)

)

)

10 REACTION  
CONTROL  
SYSTEM

1

2

3

4

5

6

11 MISCELLANEOUS

1

2

3

4

5

6



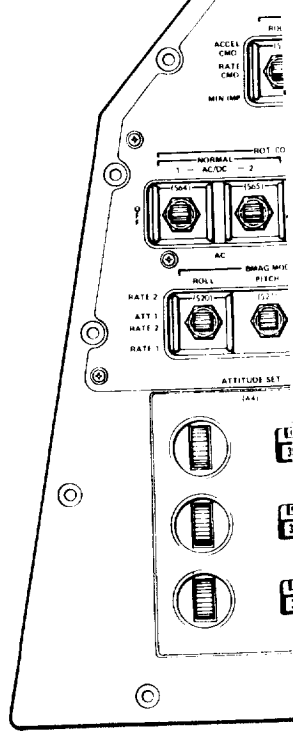
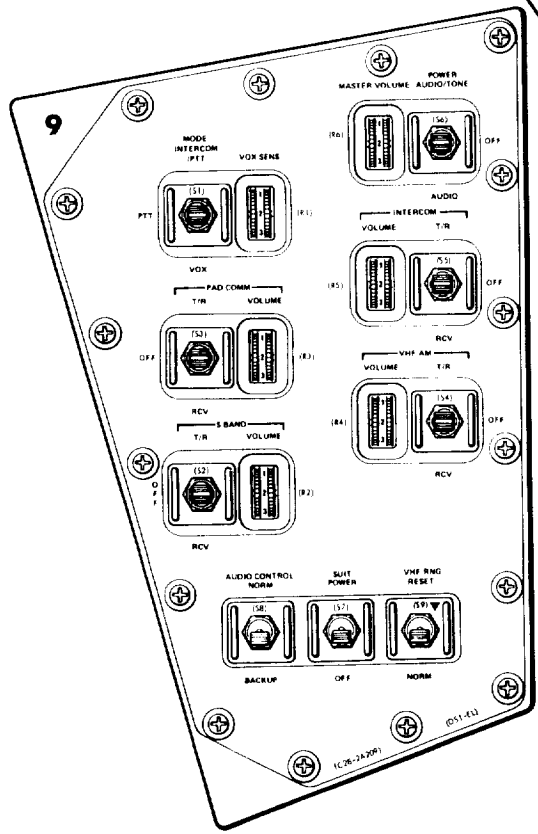
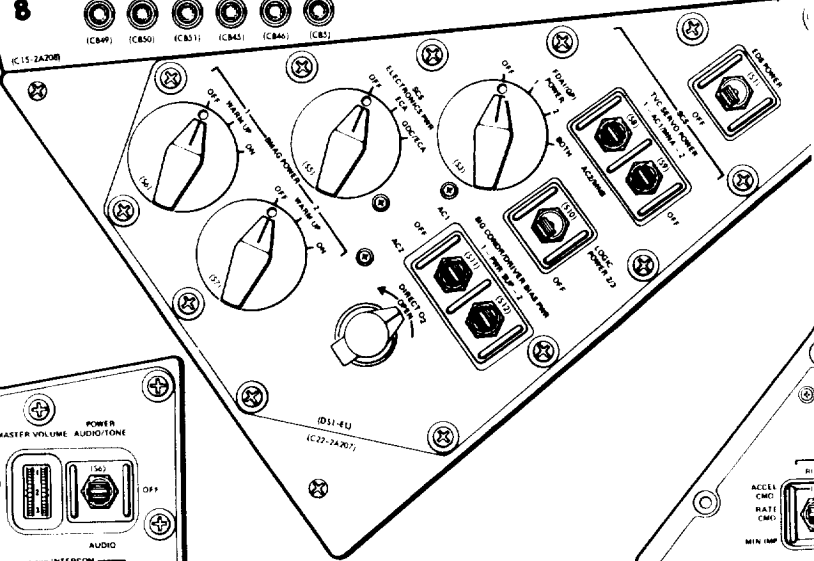
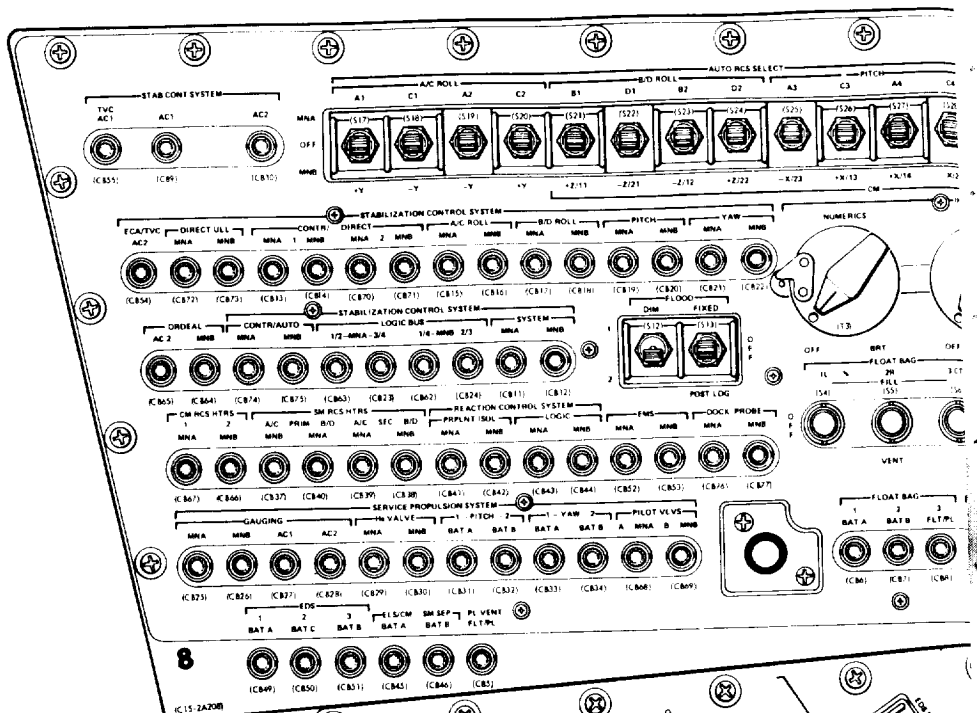

**FOLDOUT FRAME**



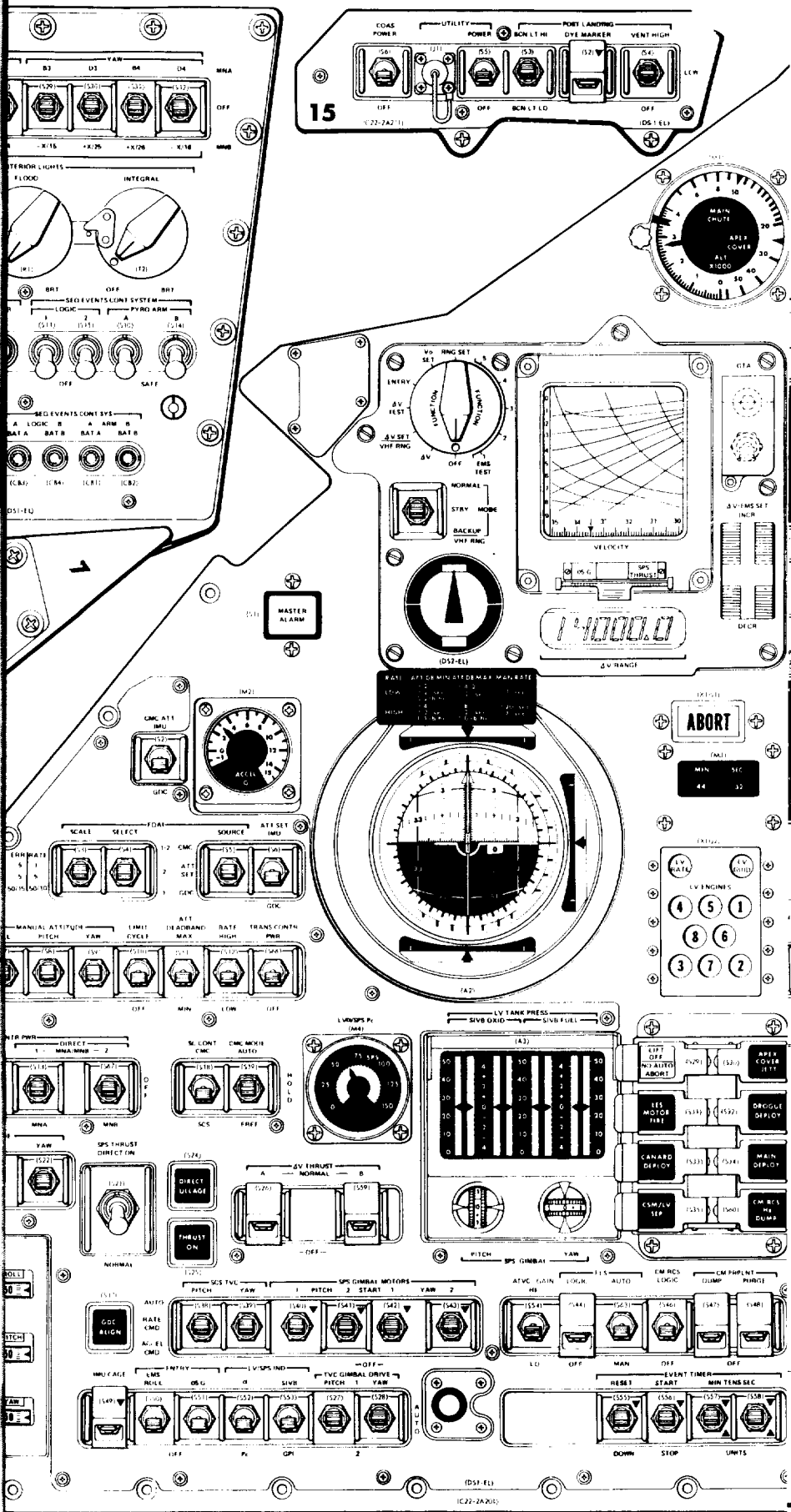

FOLDOUT FRAME 2



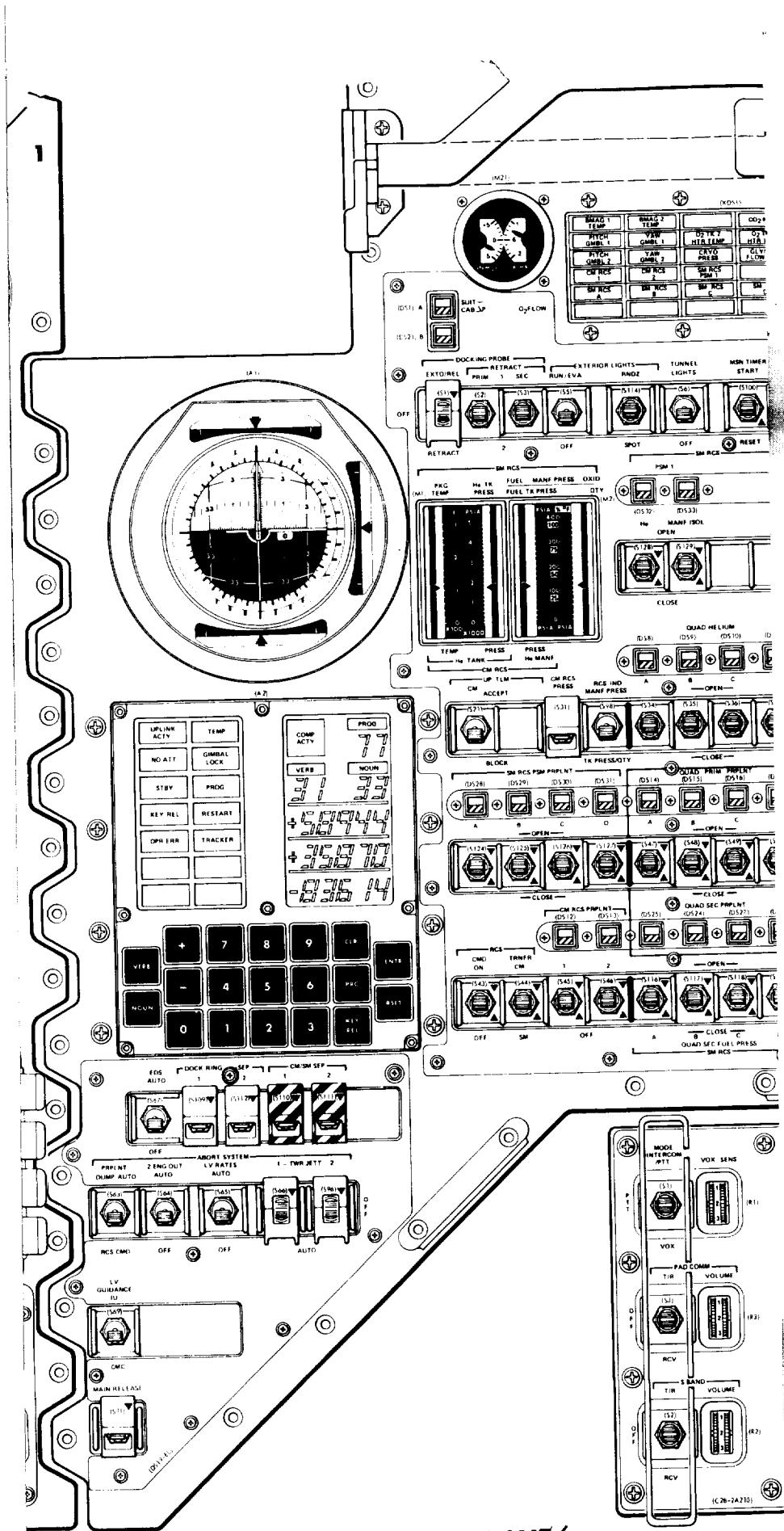

FOLDOUT FRAME 3



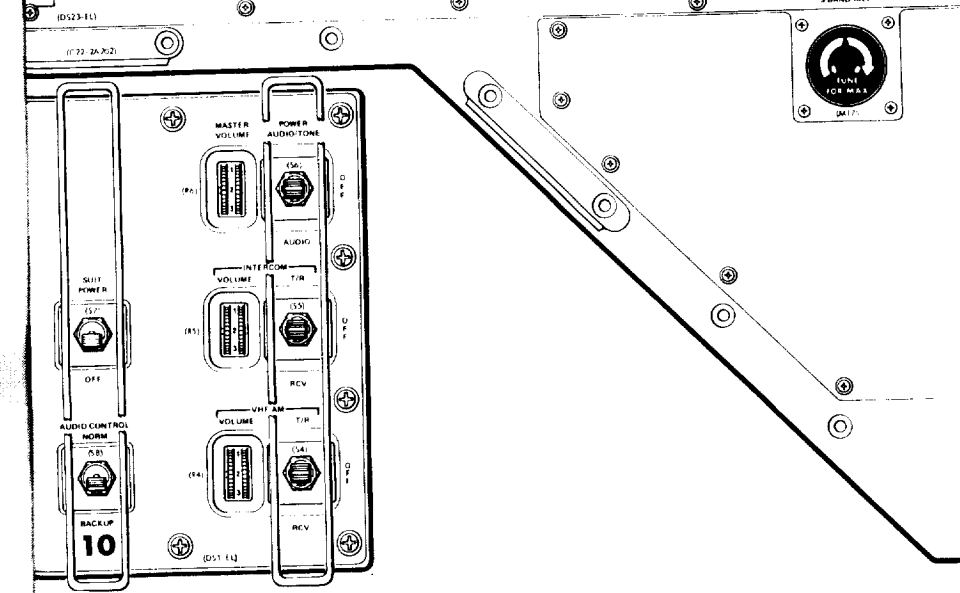
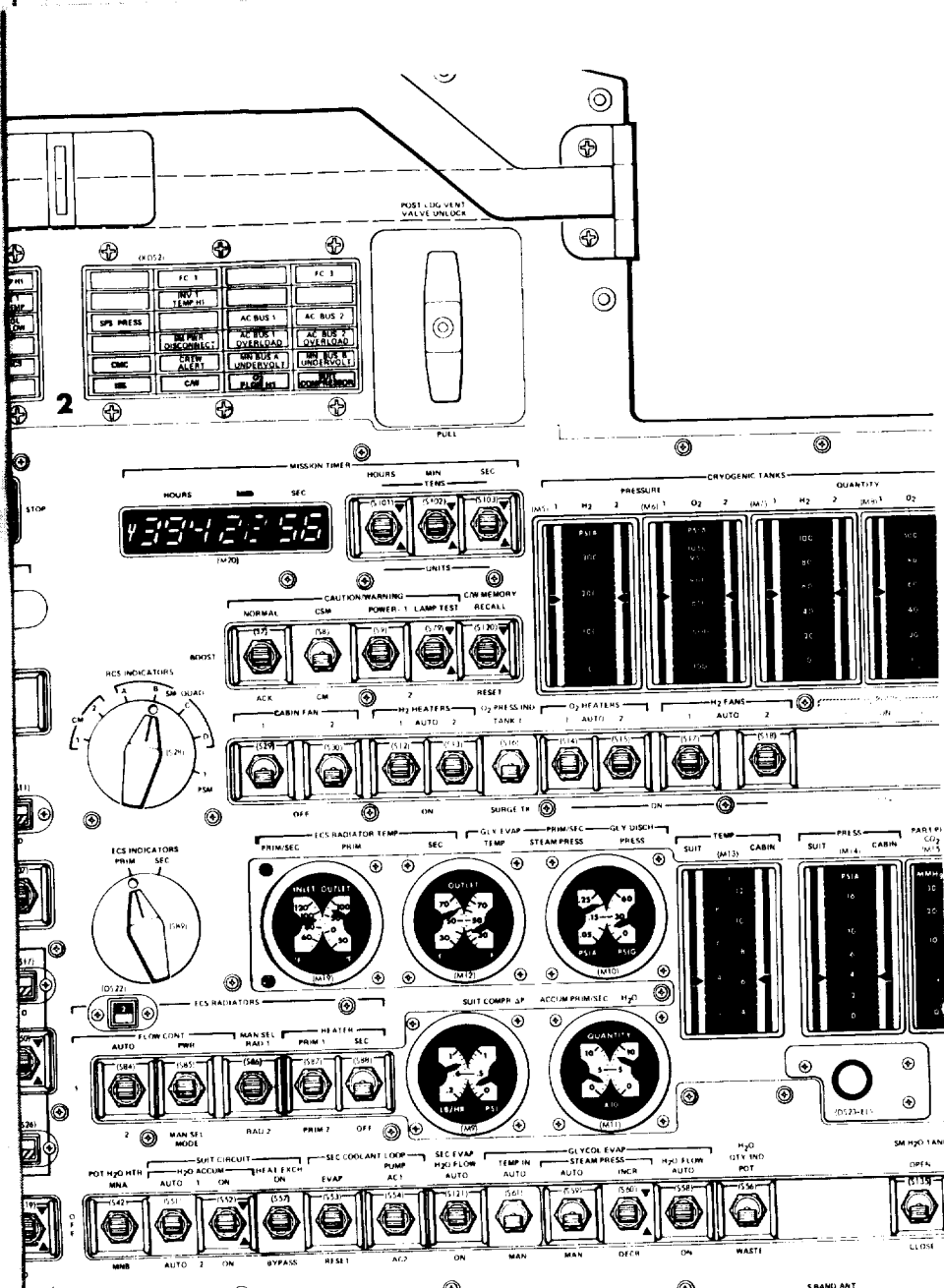

EOLDOUT FRAME 4





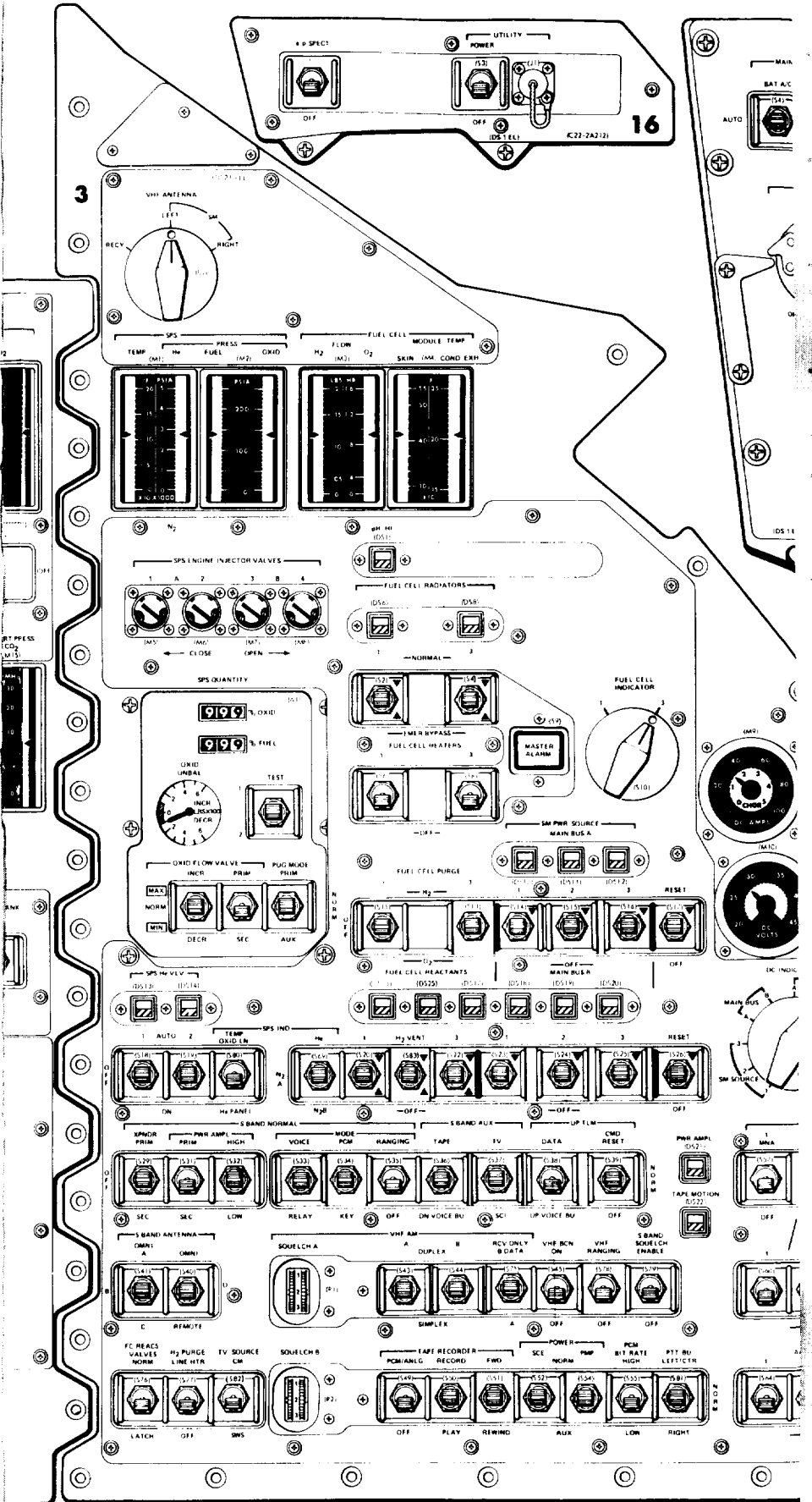

EOLDOUT FRAME 5



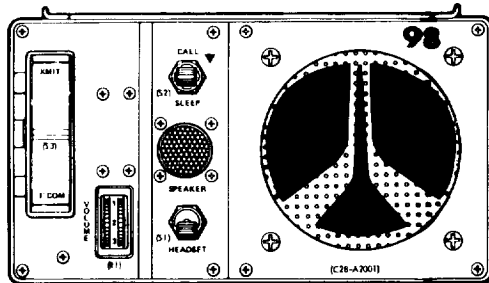
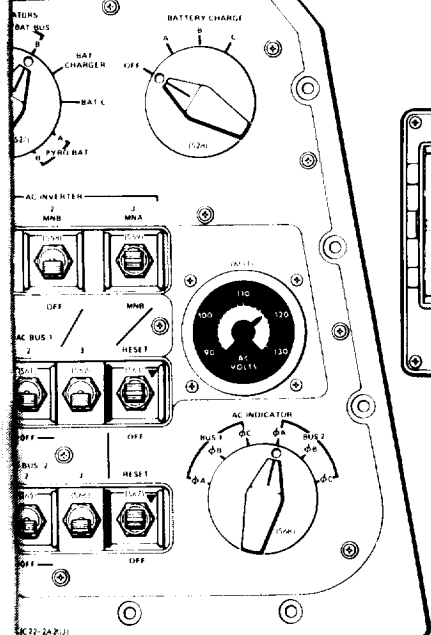
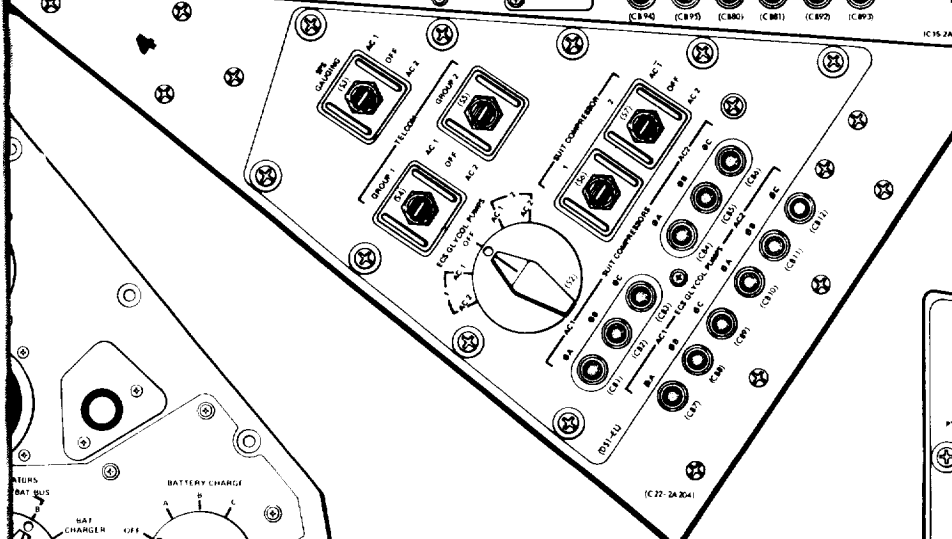
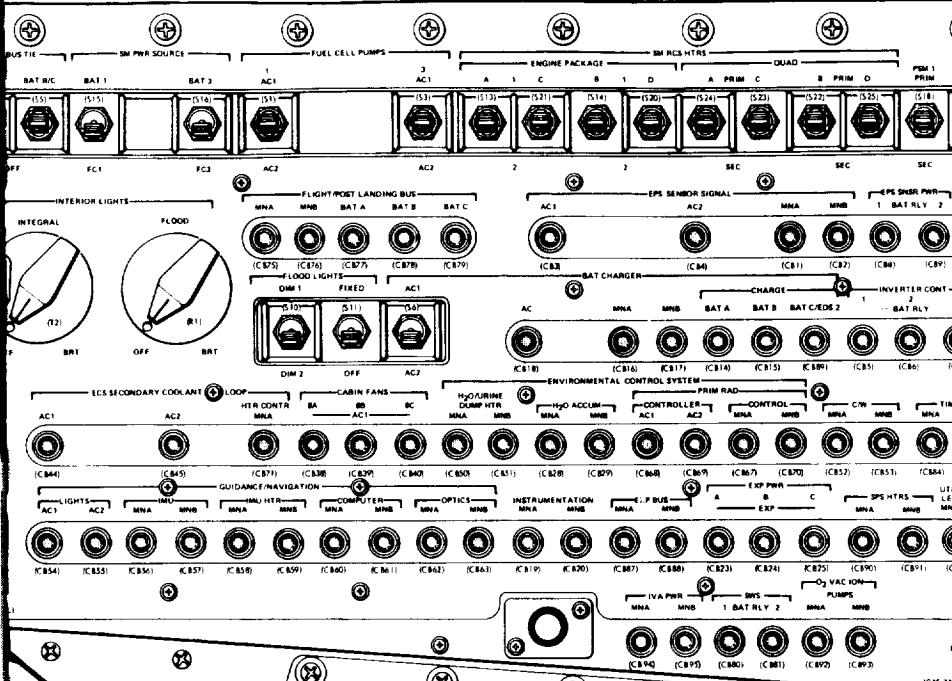



REVISIONS				
ZONE	LT#	DESCRIPTION	DATE	APPROVED

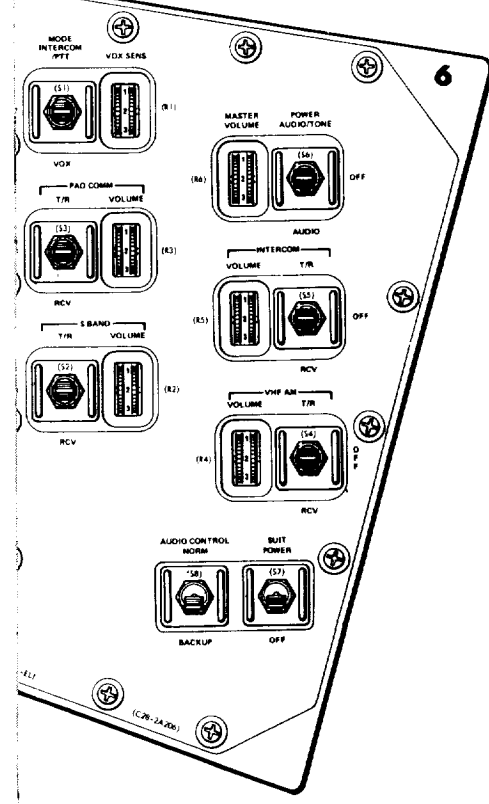
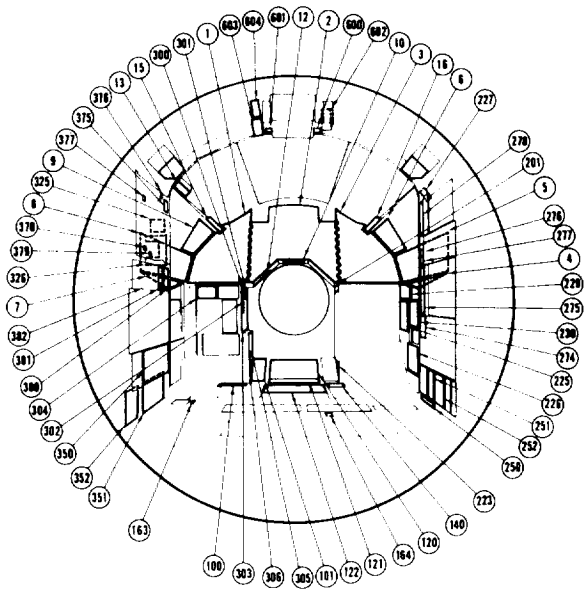
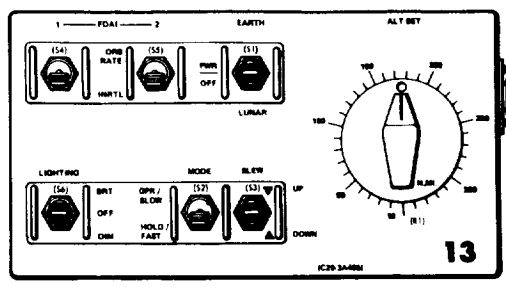
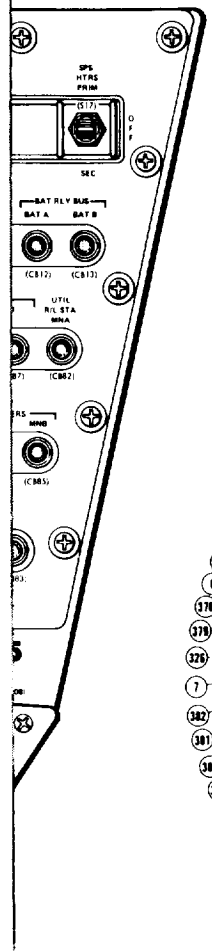

- ALL NUMBERS AND LETTERS ENCLOSED WITH PARENTHESIS DO NOT APPEAR ON PANELS.
- ▼ SYMBOL DENOTES MOMENTARY SWITCH POSITION AND DOES NOT APPEAR ON PANELS.
- SWITCH POSITIONS ARE SHOWN FOR CONVENIENCE ONLY AND DO NOT NECESSARILY REFLECT OPERATING MODES AND/OR MISSION PHASES. TWO POSITION SWITCHES ARE SHOWN IN THE DOWN POSITION, THREE POSITION SWITCHES ARE SHOWN IN CENTER POSITION.
- THIS IS AN ARRANGEMENT AND NOMENCLATURE CONTROL DWG FOR DESIGN REQUIREMENTS AND FOR USE BY OTHER DEPTS AS A GUIDE. ONLY RELEASED DESIGN DRAWINGS AND DOCUMENTS SHALL BE USED FOR MFG, MOCK-UP, SIMULATOR, EVALUATOR, TRAINER OR CENTRIFUGE PANELS WHICH ARE INTENDED TO REFLECT CURRENT DESIGN.
- THIS DWG REFLECTS A CONFIGURATION AS DEFINED BY APPLICABLE SCD'S, ASSEMBLY DWGS AND MARKING DWGS AS OF THE DATE OF RELEASE WITH RESPECT TO THE AFFECTED VEHICLES.

NOTES:

NORTH AMERICAN AVIATION, INC. SPACE and INFORMATION SYSTEMS DIVISION 1814 LAKEWOOD BLVD. DOWNEY, CALIFORNIA			
DESIGN LAYOUT: MAIN DISPLAY CONSOLE, CSM 116 BASELINE DRAWING			
SIZE	CODE IDENT NO	FIGURE 11-1	
J	03953		
8.5 X 11	PAGE 11-1	SHEET 1 OF 3	

FOLDOUT FRAME 7

11/11/2020

11/11/2020

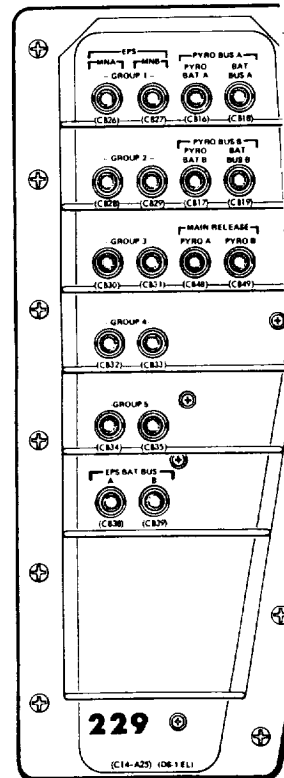
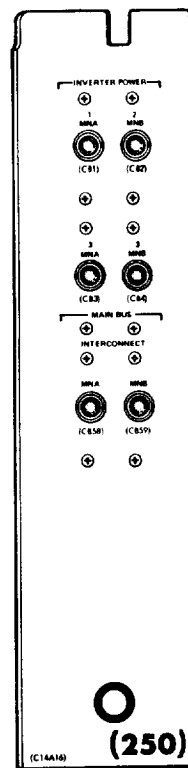
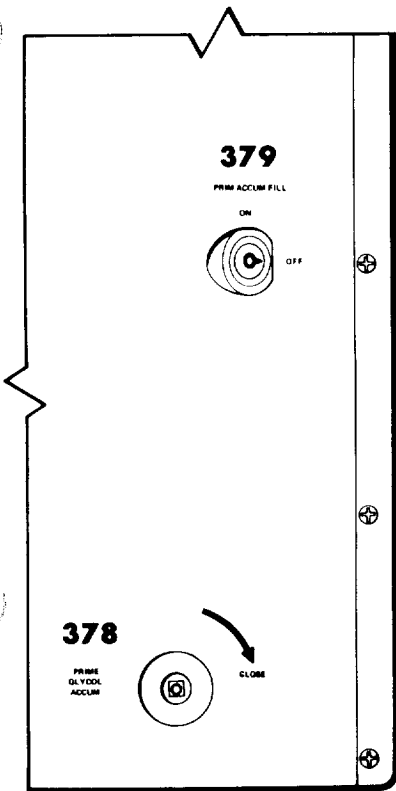
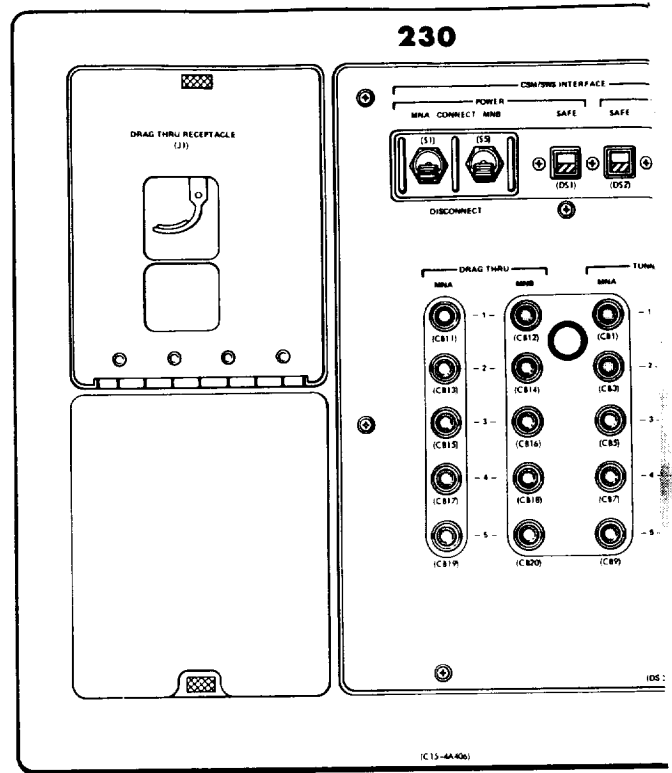
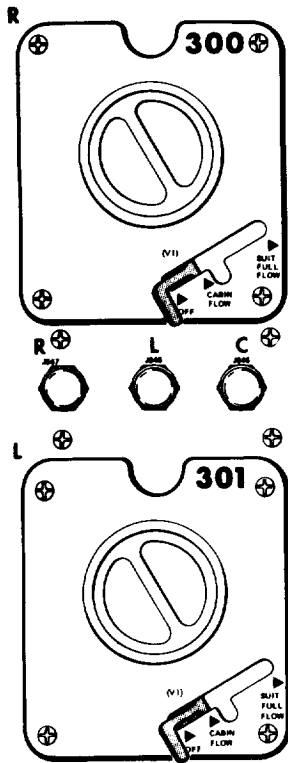

FOLDOUT FRAME

•••••



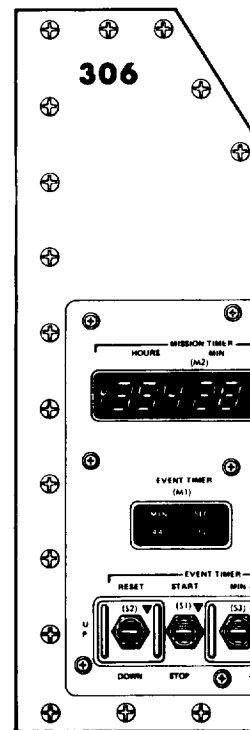
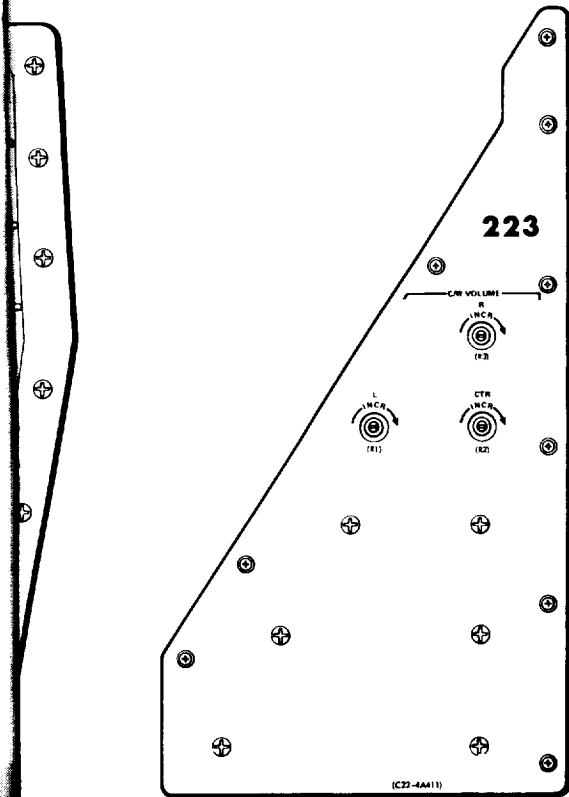
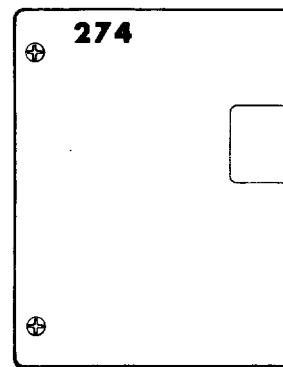
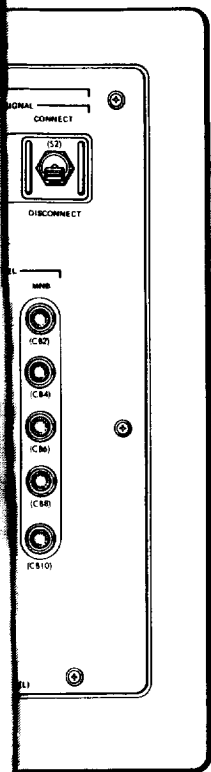

FOLDOUT FRAME 2



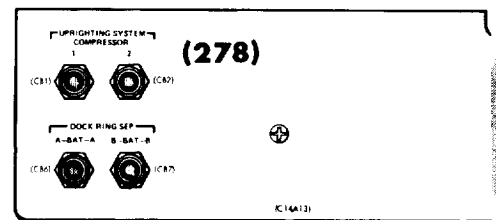
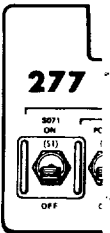
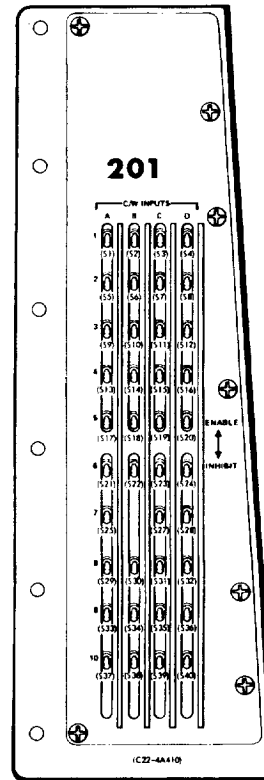
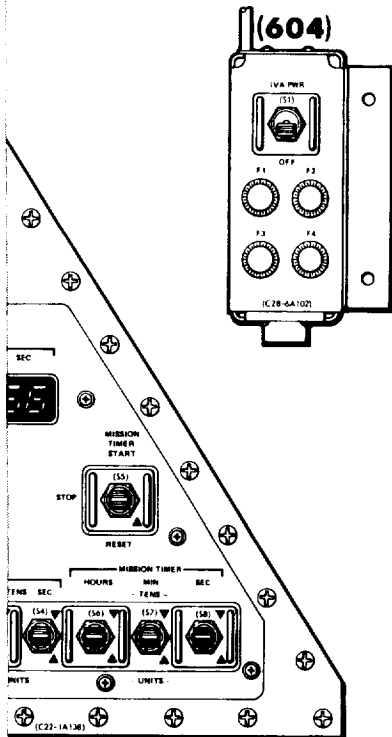
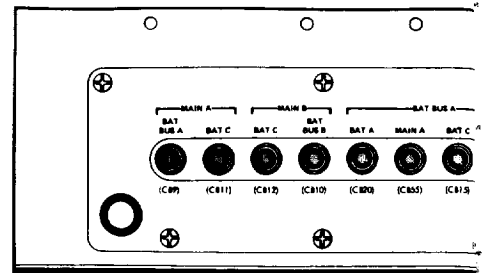
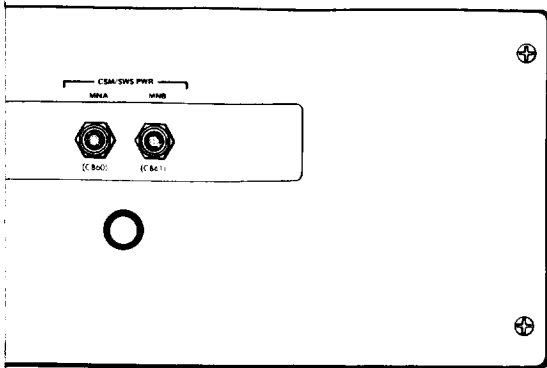

FOLDOUT FRAME 3



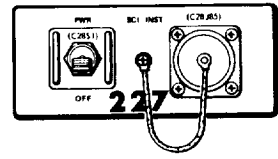
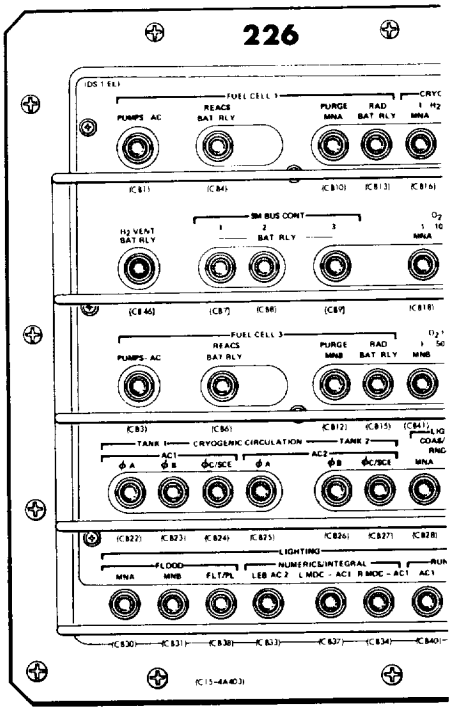
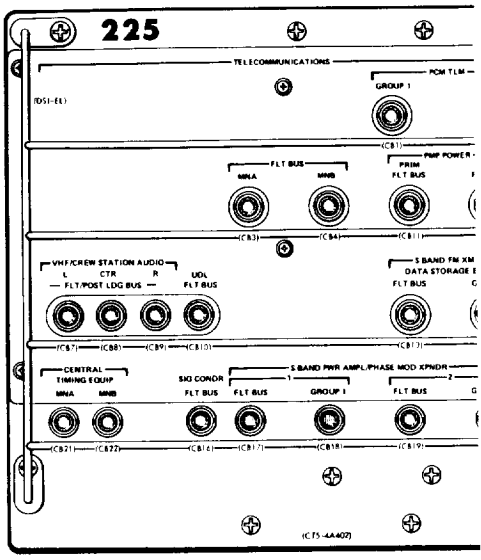
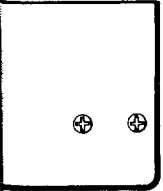
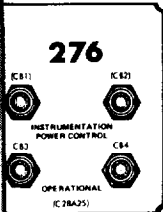
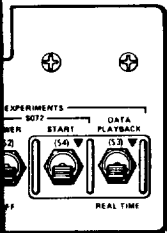
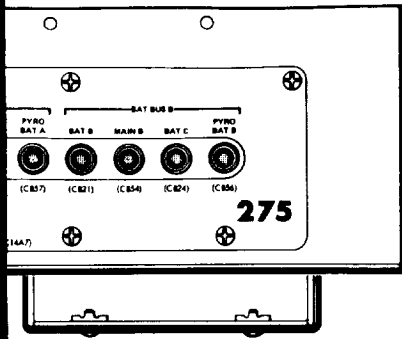

FOLDOUT FRAME 4



DATE	ENGR	DR	PCB	LTR
COMMENTS:				

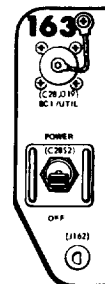
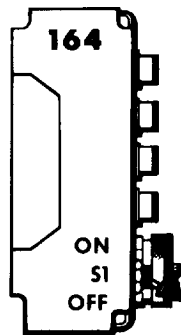
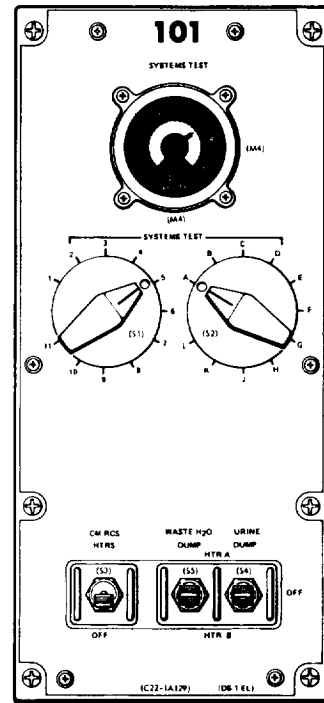
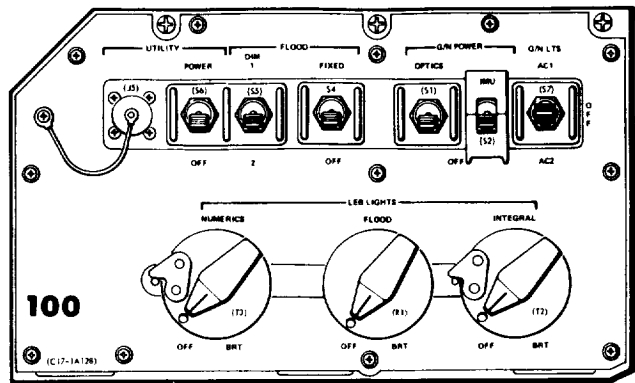
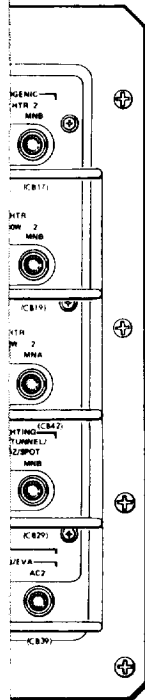
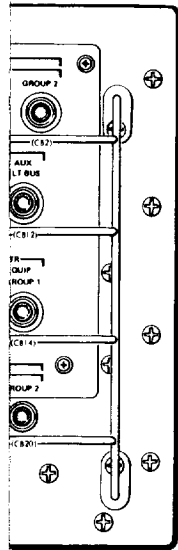

NATIONAL AERONAUTICS & SPACE ADMINISTRATION MANNED SPACECRAFT CENTER - HOUSTON, TEXAS			
DESIGN LAYOUT - MAIN DISPLAY CONSOLE CSM 116 BASELINE DRAWING			
DWG NO		FIGURE 11-1	
52 X 17	PAGE 11-2	SHEET 2 OF 3	

EQLDOUT FRAME 5

1000

1000

1



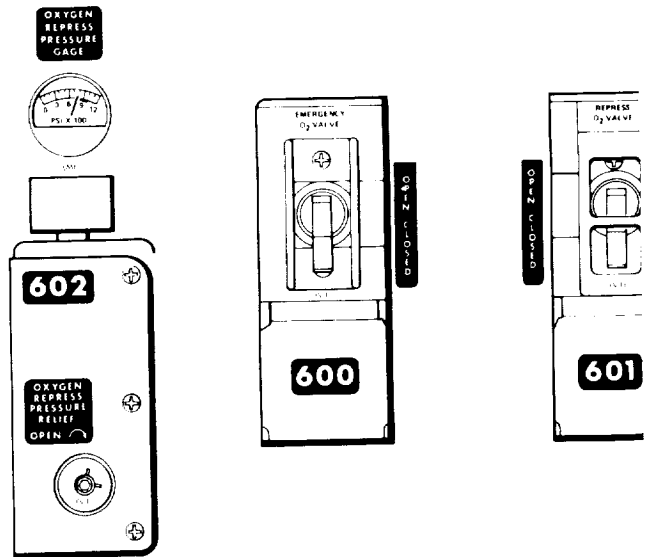
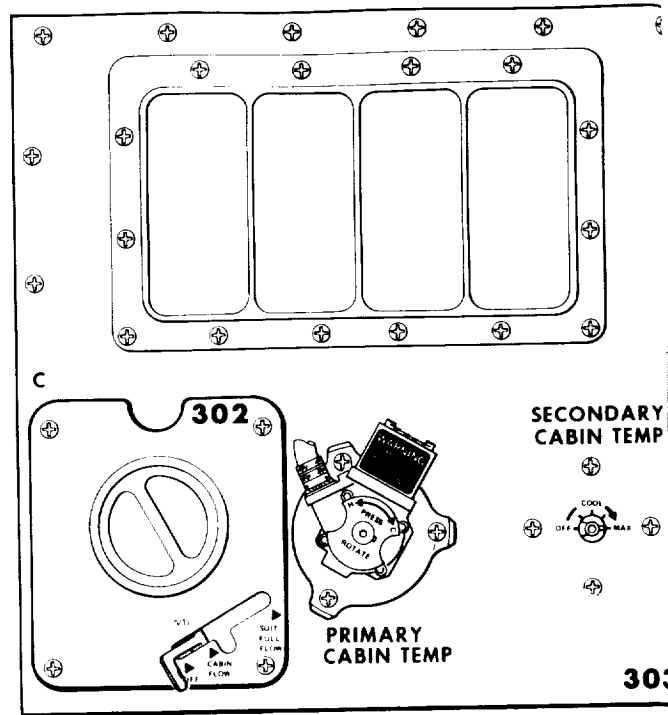

**FOLDOUT FRAME**

10/11/2023

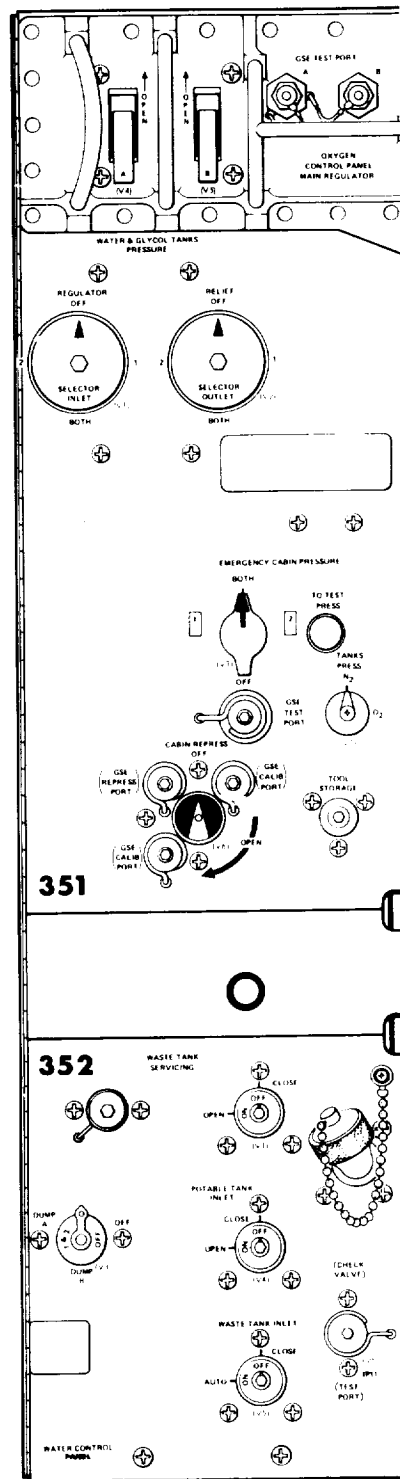
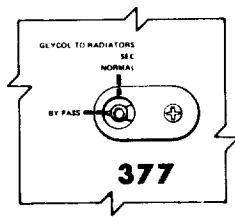
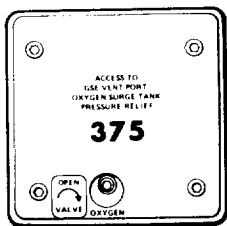
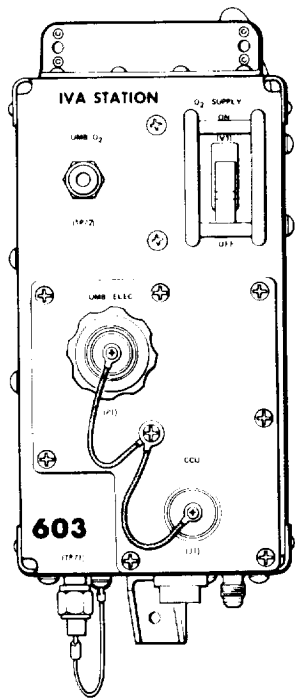
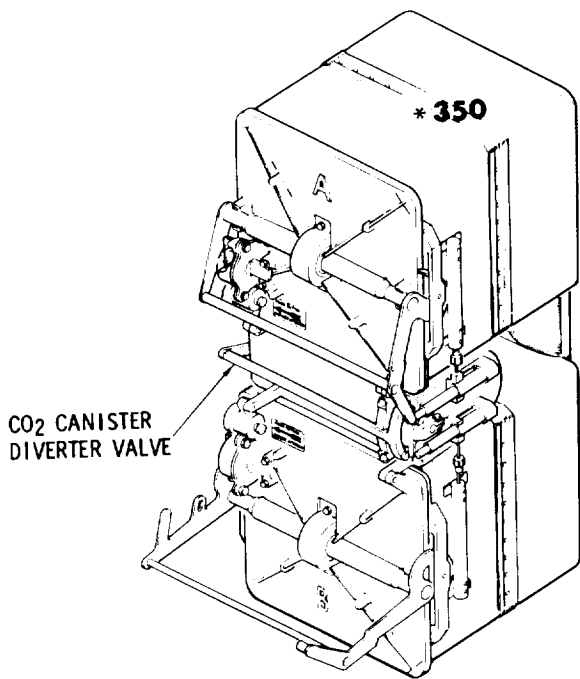

FOLDOUT FRAME 2



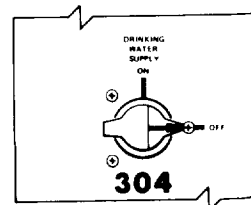
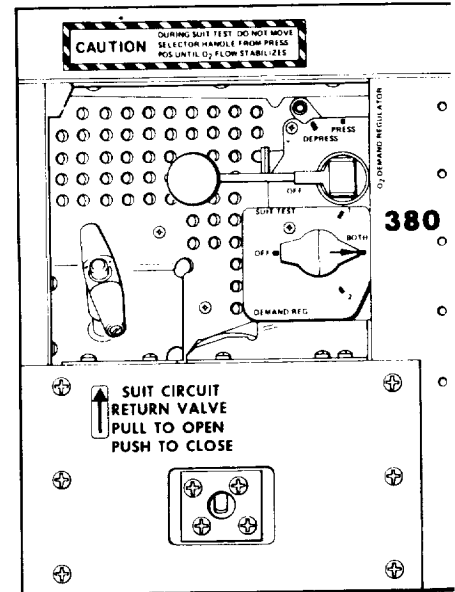
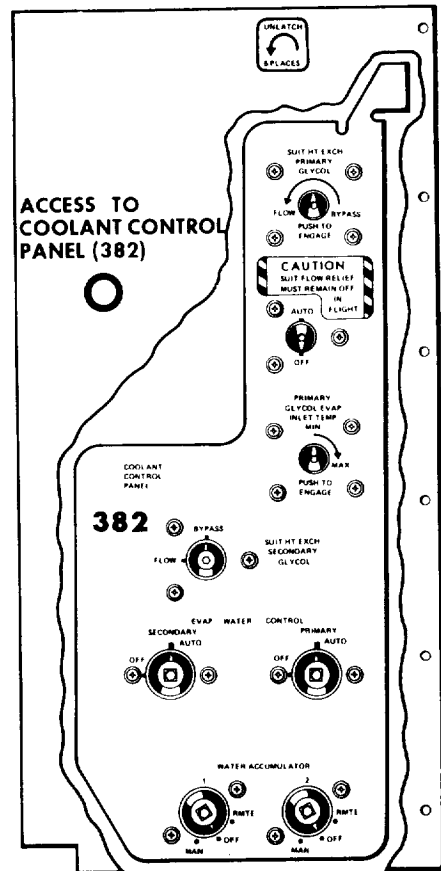
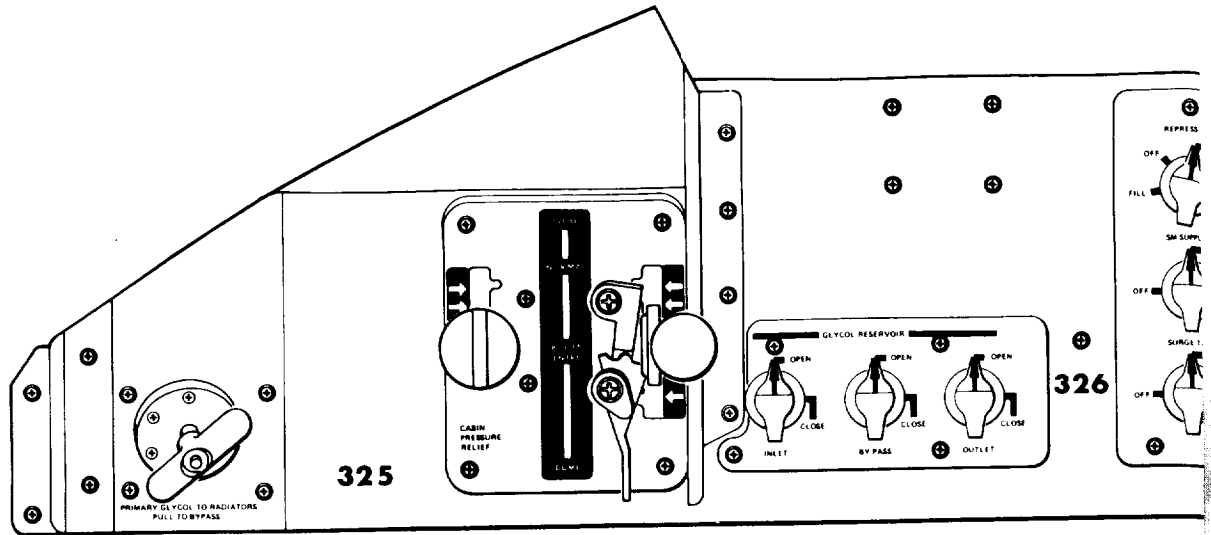



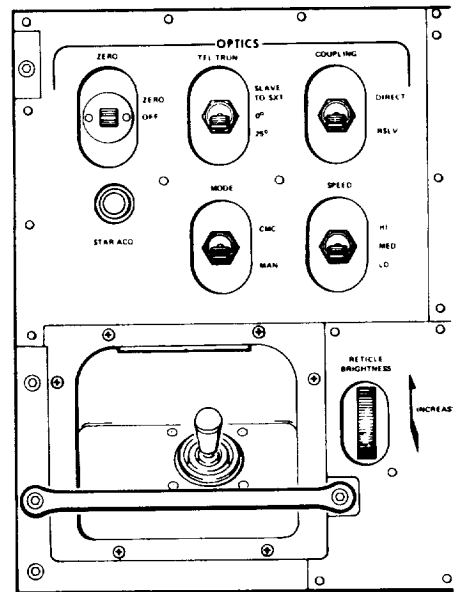
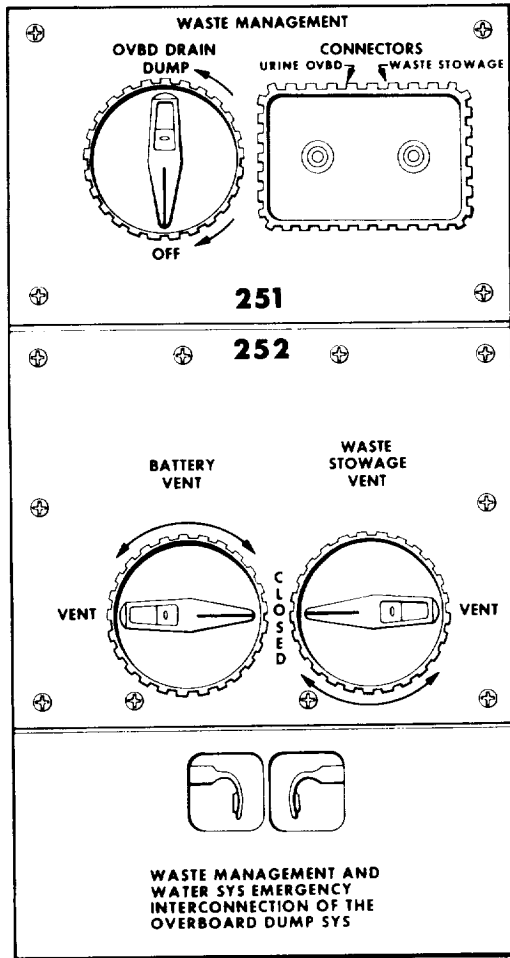
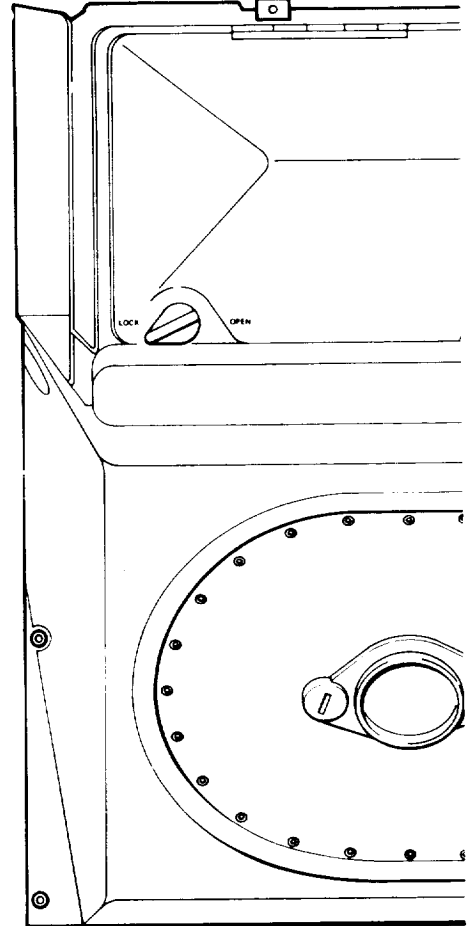
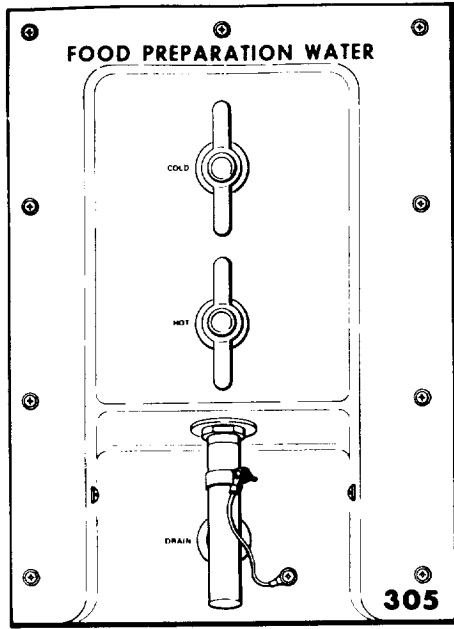
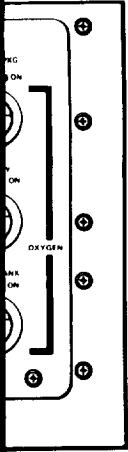

FOLDOUT FRAME 4





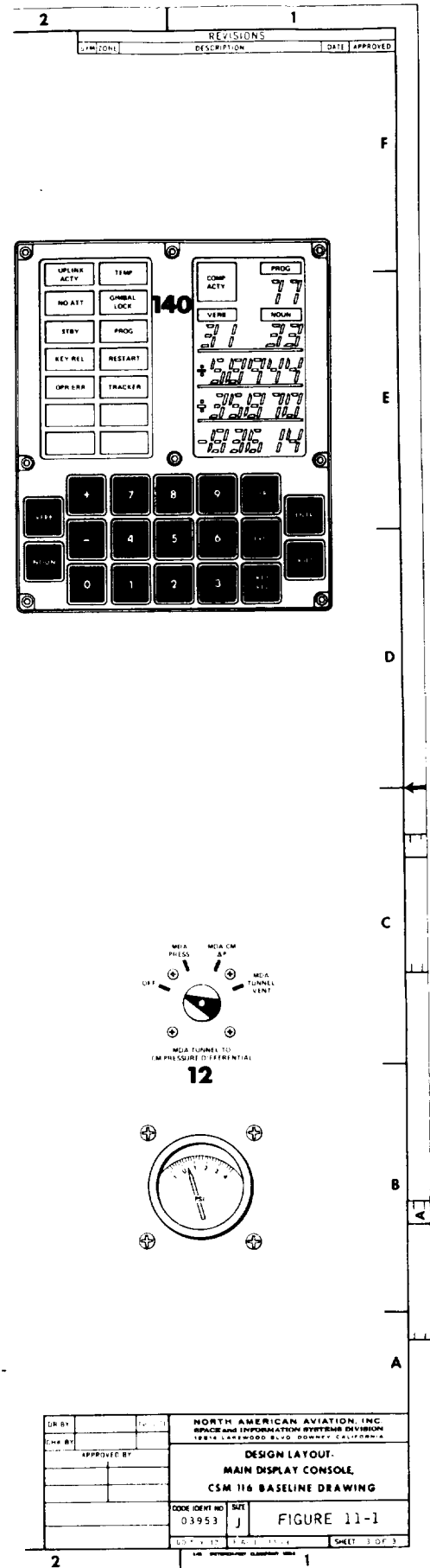
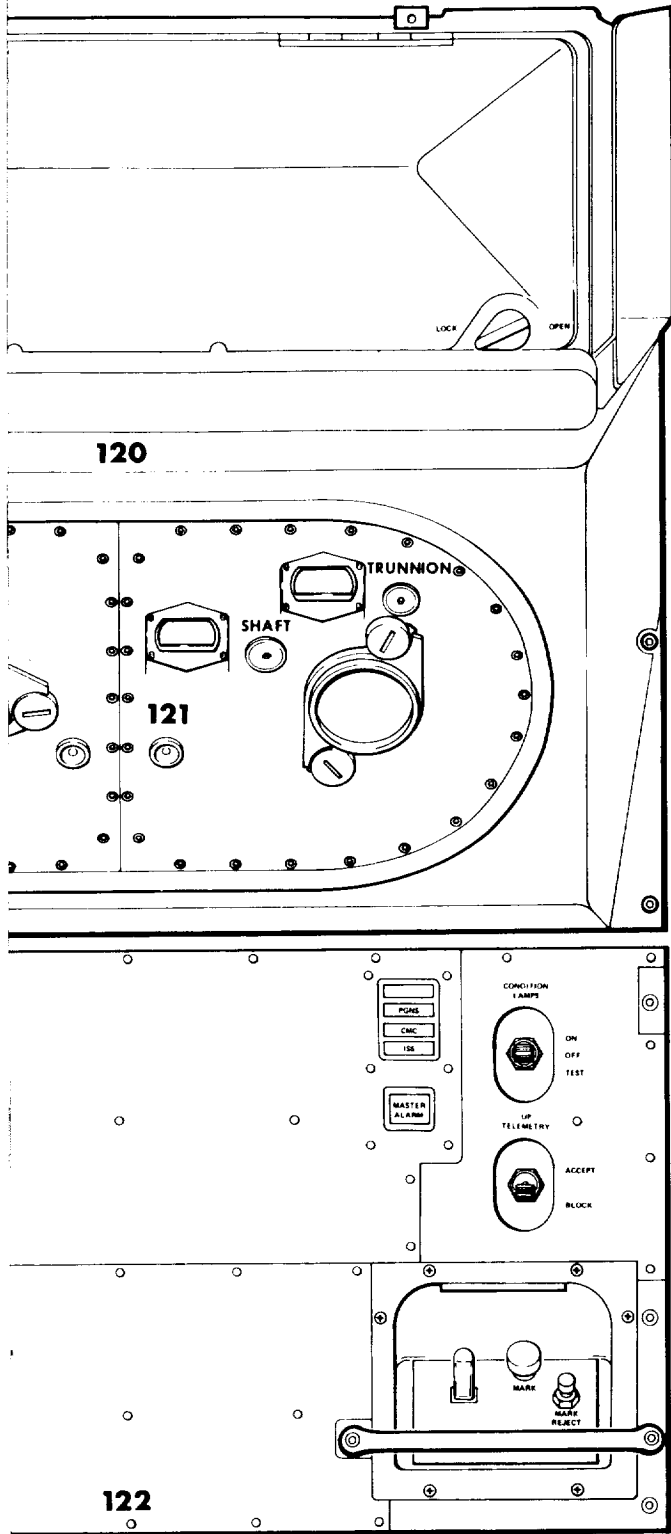

**EQLDOUT FRAME 5**

10/10/10

1

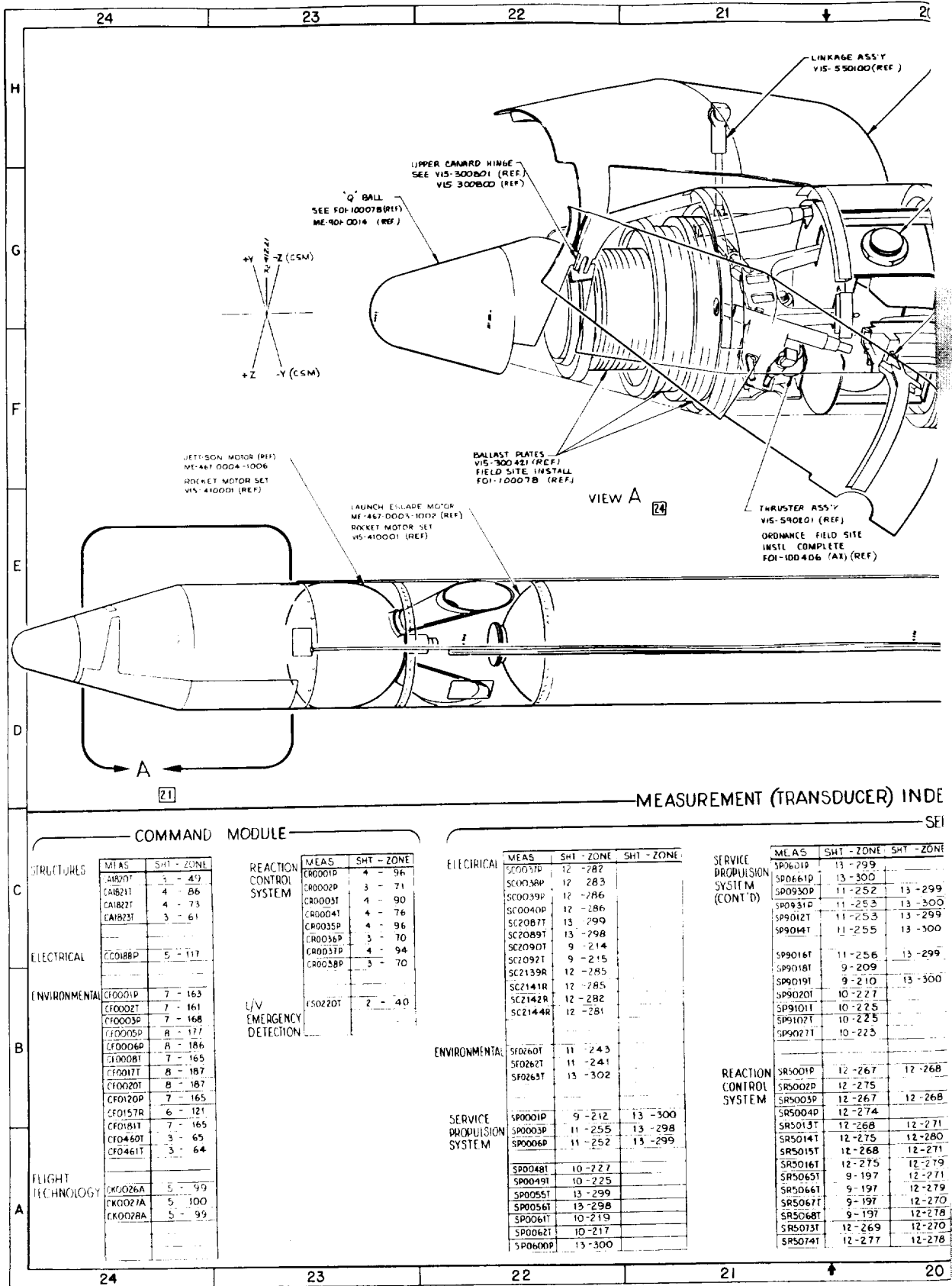

MEASUREMENT (TRANSDUCER) INDEX

SEI

COMMAND MODULE

STRUCTURES	MEAS	SHT	ZONE
AI8207	3	49	
CA18211	4	86	
CA18217	4	73	
EA18231	3	61	
ELECTRICAL			
CC0188P	5	117	
ENVIRONMENTAL			
CF0001P	7	163	
CF0002T	7	161	
CF0003P	7	168	
CF0005P	8	177	
CF0006P	8	186	
CF0008T	7	165	
CF0017T	8	187	
CF0020T	8	187	
CF0120P	7	165	
CF0157R	6	121	
CF0181T	7	165	
CF0460T	3	65	
CF0461T	3	64	
FLIGHT TECHNOLOGY			
CK0026A	5	99	
CK0027A	5	100	
CK0028A	5	99	

REACTION CONTROL SYSTEM	MEAS	SHT	ZONE
CR0001P	4	96	
CR0002P	3	71	
CR0003T	4	90	
CR0004T	4	76	
CR0035P	4	96	
CR0036P	3	70	
CR0037P	4	94	
CR0038P	3	70	
L/V EMERGENCY DETECTION			
E50220T	2	40	

ELECTRICAL	MEAS	SHT	ZONE	SHT	ZONE
SC0037P	12	282			
SC0038P	12	283			
SC0039P	12	286			
SC0040P	12	286			
SC2087T	13	299			
SC2089T	13	298			
SC2090T	9	214			
SC2092T	9	215			
SC2139R	12	285			
SC2141R	12	285			
SC2142R	12	282			
SC2144R	12	281			
ENVIRONMENTAL					
SF0260T	11	243			
SF0262T	11	241			
SF0263T	13	302			
SERVICE PROPULSION SYSTEM					
SP0001P	9	212	13	300	
SP0003P	11	255	13	298	
SP0006P	11	252	13	299	
SP0048T	10	227			
SP0049T	10	225			
SP0055T	13	299			
SP0056T	13	298			
SP0061T	10	219			
SP0062T	10	217			
SP0600P	13	300			

SERVICE PROPULSION SYSTEM (CONT'D)	MEAS	SHT	ZONE	SHT	ZONE
SP0601P	13	299			
SP0661P	13	300			
SP0930P	11	252	13	299	
SP0931P	11	253	13	300	
SP0912T	11	253	13	299	
SP0904T	11	255	13	300	
SP0916T	11	256	13	299	
SP0918T	9	209			
SP0919T	9	210	13	300	
SP0920T	10	227			
SP0910T	10	225			
SP0910T	10	225			
SP0902T	10	225			
REACTION CONTROL SYSTEM					
SR5001P	12	267	12	268	
SR5002P	12	275			
SR5003P	12	267	12	268	
SR5004P	12	274			
SR5013T	12	268	12	271	
SR5014T	12	275	12	280	
SR5015T	12	268	12	271	
SR5016T	12	275	12	279	
SR5065T	9	197	12	271	
SR5066T	9	197	12	279	
SR5067T	9	197	12	270	
SR5068T	9	197	12	278	
SR5073T	12	269	12	270	
SR5074T	12	277	12	278	

FOLDOUT FRAME



CANARD IN OPEN POSITION

PITCH CONTROL MOTOR  
ME-467-0005-1001 (REF)  
ROCKET MOTOR SET  
V5-410001 (REF)

LOWER CANARD HINGE  
SEE V15-300801 (REF)  
V15-300800 (REF)

LAUNCH ESCAPE SYSTEM  
MARKING DRAWING  
V35-000010 (REF)

TOWER ASSY LAUNCH ESCAPE SYS.  
V18-300100 (REF)  
BODY GROUP ASSY LAUNCH ESCAPE SYS.  
V35-300001 (REF)  
LAUNCH ESCAPE SYS, FIELD SITE INSTL.  
F01-100078 (REF)  
GENERAL ASSY LAUNCH ESCAPE SYS.  
V35-000002 (REF)

WIRE HARNESS INSTL  
V35-441011 (REF)  
ELECTRICAL INSTL  
LAUNCH ESCAPE S  
V35-440001 (REF)  
ELEC FIELD SITE INSTL  
F01-445001 (REF)

PANEL MEGA  
V36-321101

UNIFIED CRT  
WATCH INSTL  
REF

RENDERING R  
V36-321520

SERVICE MODULE

REACTION  
CONTROL  
SYSTEM  
(CONT'D)

MEAS	SHT -ZONE	SHT -ZONE	SHT -ZONE
SR5015T	12-269	12-270	
SR5016T	12-277	12-277	
SR5729P	12-266	12-266	
SR5716P	12-274		
SR5817P	12-265	12-266	
SR5830P	12-274		
SR5733P	12-267	12-270	
SR5780P	12-276	12-278	12-279
SR5820P	12-267	12-270	
SR5821P	12-276	12-277	
SR5737P	12-271		
SR5784P	12-280		
SR5822P	12-270		
SR5823P	12-279	12-279	
SR9715T	12-269		
SR9716T	12-276		
SR9415T	12-269		
SR9515T	12-275		
SR9740P		13-291	13-299
SR9741P		13-291	13-299
SR9802T	13-290	13-294	
SR9902T	13-291		
SR9904P	13-295	13-295	
SR9904P	13-294		
SR9906P	13-294	13-295	
SR9904P	13-294		
SR9907P	13-294	13-296	
SR9907P	13-295		
SR9908T	13-291	13-295	
SR9908T	13-290		

REACTION  
CONTROL  
SYSTEM  
(CONT'D)

MEAS	SHT -ZONE	SHT -ZONE
SR9809T	13-295	13-296
SR9909T	13-294	

C/M HEATSHIELD ASSY  
COMPLETE V36-321001  
C/M OUTER  
ABLATIVE OUTER M  
MD-116-16-D-6 (REF)  
BOOST PROTECTIVE COVER, OUTER  
V35-300680 AND F01-100057 (REF)  
ABLATIVE CORK, OUTER M (REF)

FOR ADDITIONAL INFO  
SEE ZC

11/11/2023

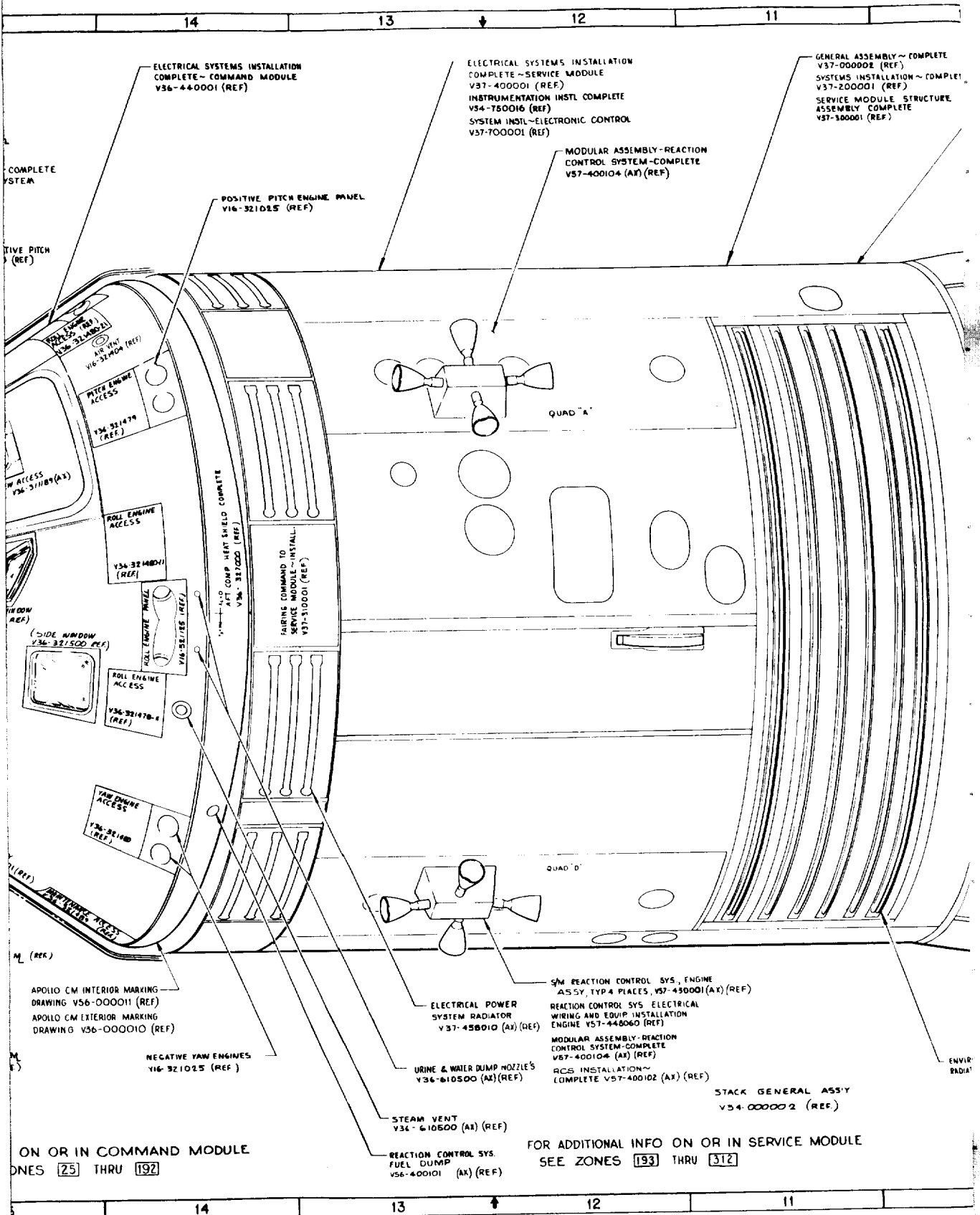

ON OR IN COMMAND MODULE  
ZONES 25 THRU 192

FOR ADDITIONAL INFO ON OR IN SERVICE MODULE  
SEE ZONES 193 THRU 312

**EXPLODED FRAME 3**

1000



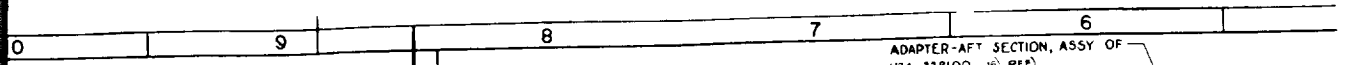

SERVICE MODULE INTERIOR  
MARKINGS V37-000011 (REF)  
SERVICE MODULE EXTERIOR, MARKINGS  
& FINISH V37-000010 (REF)

FIELD SITE INSTALLATION,  
DRDANCE-COMLETE  
FDI-100406 (AR) (REF)

ADAPTER-AFT SECTION, ASSY OF  
V24-328100 (REF)  
STABILIZING DEVICE ASSEMBLY-  
STRUCTURE V24-328171 (REF)

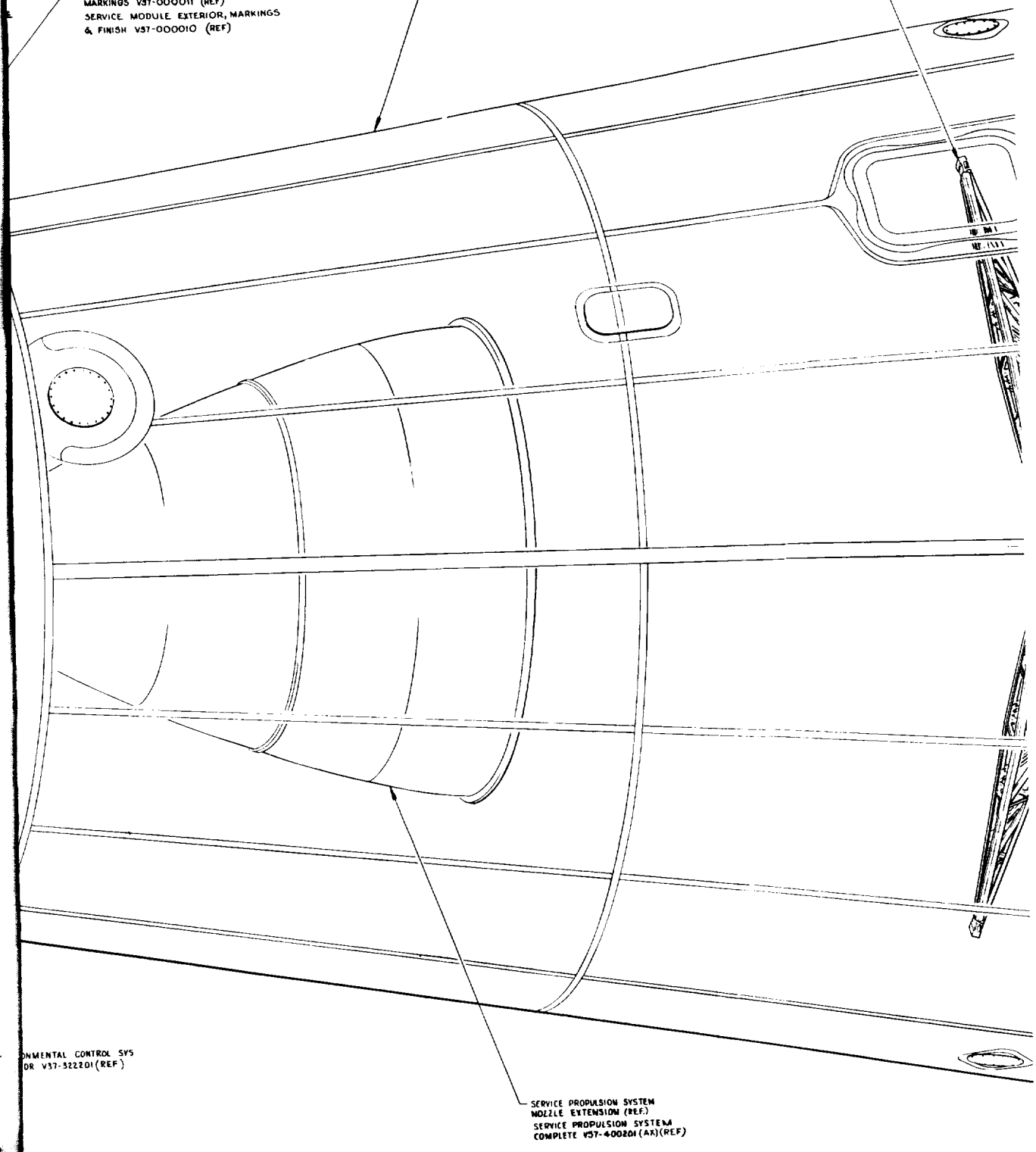

ENVIRONMENTAL CONTROL SYS  
OR V37-322201 (REF)

SERVICE PROPULSION SYSTEM  
NOZZLE EXTENSION (REF)  
SERVICE PROPULSION SYSTEM  
COMPLETE V37-400201 (AR) (REF)

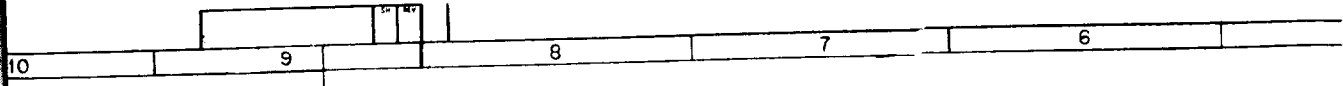

FOLDOUT FRAME 4

1

2

3

4

5

6

7

8

9

10

11

12

13

14

15

16

17

18

19

20

21

22

23

24

25

26

27

28

29

30

31

32

33

34

35

36

37

38

39

40

41

42

43

44

45

46

47

48

49

50

51

52

53

54

55

56

57

58

59

60

61

62

63

64

65

66

67

68

69

70

71

72

73

74

75

76

77

78

79

80

81

82

83

84

85

86

87

88

89

90

91

92

93

94

95

96

97

98

99

100

101

102

103

104

105

106

107

108

109

110

111

112

113

114

115

116

117

118

119

120

121

122

123

124

125

126

127

128

129

130

131

132

133

134

135

136

137

138

139

140

141

142

143

144

145

146

147

148

149

150

151

152

153

154

155

156

157

158

159

160

161

162

163

164

165

166

167

168

169

170

171

172

173

174

175

176

177

178

179

180

181

182

183

184

185

186

187

188

189

190

191

192

193

194

195

196

197

198

199

200

201

202

203

204

205

206

207

208

209

210

211

212

213

214

215

216

217

218

219

220

221

222

223

224

225

226

227

228

229

230

231

232

233

234

235

236

237

238

239

240

241

242

243

244

245

246

247

248

249

250

251

252

253

254

255

256

257

258

259

260

261

262

263

264

265

266

267

268

269

270

271

272

273

274

275

276

277

278

279

280

281

282

283

284

285

286

287

288

289

290

291

292

293

294

295

296

297

298

299

300

301

302

303

304

305

306

307

308

309

310

311

312

313

314

315

316

317

318

319

320

321

322

323

324

325

326

327

328

329

330

331

332

333

334

335

336

337

338

339

340

341

342

343

344

345

346

347

348

349

350

351

352

353

354

355

356

357

358

359

360

361

362

363

364

365

366

367

368

369

370

371

372

373

374

375

376

377

378

379

380

381

382

383

384

385

386

387

388

389

390

391

392

393

394

395

396

397

398

399

400

401

402

403

404

405

406

407

408

409

410

411

412

413

414

415

416

417

418

419

420

421

422

423

424

425

426

427

428

429

430

431

432

433

434

435

436

437

438

439

440

441

442

443

444

445

446

447

448

449

450

451

452

453

454

455

456

457

458

459

460

461

462

463

464

465

466

467

468

469

470

471

472

473

474

475

476

477

478

479

480

481

482

483

484

485

486

487

488

489

490

491

492

493

494

495

496

497

498

499

500

501

502

503

504

505

506

507

508

509

510

511

512

513

514

515

516

517

518

519

520

521

522

523

524

525

526

527

528

529

530

531

532

533

534

535

536

537

538

539

540

541

542

543

544

545

546

547

548

549

550

551

552

553

554

555

556

557

558

559

560

561

562

563

564

565

566

567

568

569

570

571

572

573

574

575

576

577

578

579

580

581

582

583

584

585

586

587

588

589

590

591

592

593

594

595

596

597

598

599

600

601

602

603

604

605

606

607

608

609

610

611

612

613

614

615

616

617

618

619

620

621

622

623

624

625

626

627

628

629

630

631

632

633

634

635

636

637

638

639

640

641

642

643

644

645

646

647

648

649

650

651

652

653

654

655

656

657

658

659

660

661

662

663

664

665

666

667

668

669

670

671

672

673

674

675

676

677

678

679

680

681

682

683

684

685

686

687

688

689

690

691

692

693

694

695

696

697

698

699

700

701

702

703

704

705

706

707

708

709

710

711

712

713

714

715

716

717

718

719

720

721

722

723

724

725

726

727

728

729

730

731

732

733

734

735

736

737

738

739

740

741

742

743

744

745

746

747

748

749

750

751

752

753

754

755

756

757

758

759

760

761

762

763

764

765

766

767

768

769

770

771

772

773

774

775

776

777

778

779

780

781

782

783

784

785

786

787

788

789

790

791

792

793

794

795

796

797

798

799

800

801

802

803

804

805

806

807

808

809

810

811

812

813

814

815

816

817

818

819

820

821

822

823

824

825

826

827

828

829

830

831

832

833

834

835

836

837

838

839

840

841

842

843

844

845

846

847

848

849

850

851

852

853

854

855

856

857

858

859

860

861

862

863

864

865

866

867

868

869

870

871

872

873

874

875

876

877

878

879

880

881

882

883

884

885

886

887

888

889

890

891

892

893

894

895

896

897

898

899

900

901

902

903

904

905

906

907

908

909

910

911

912

913

914

915

916

917

918

919

920

921

922

923

924

925

926

927

928

929

930

931

932

933

934

935

936

937

938

939

940

941

942

943

944

945

946

947

948

949

950

951

952

953

954

955

956

957

958

959

960

961

962

963

964

965

966

967

968

969

970

971

972

973

974

975

976

977

978

979

980

981

982

983

984

985

986

987

988

989

990

991

992

993

994

995

996

997

998

999

1000

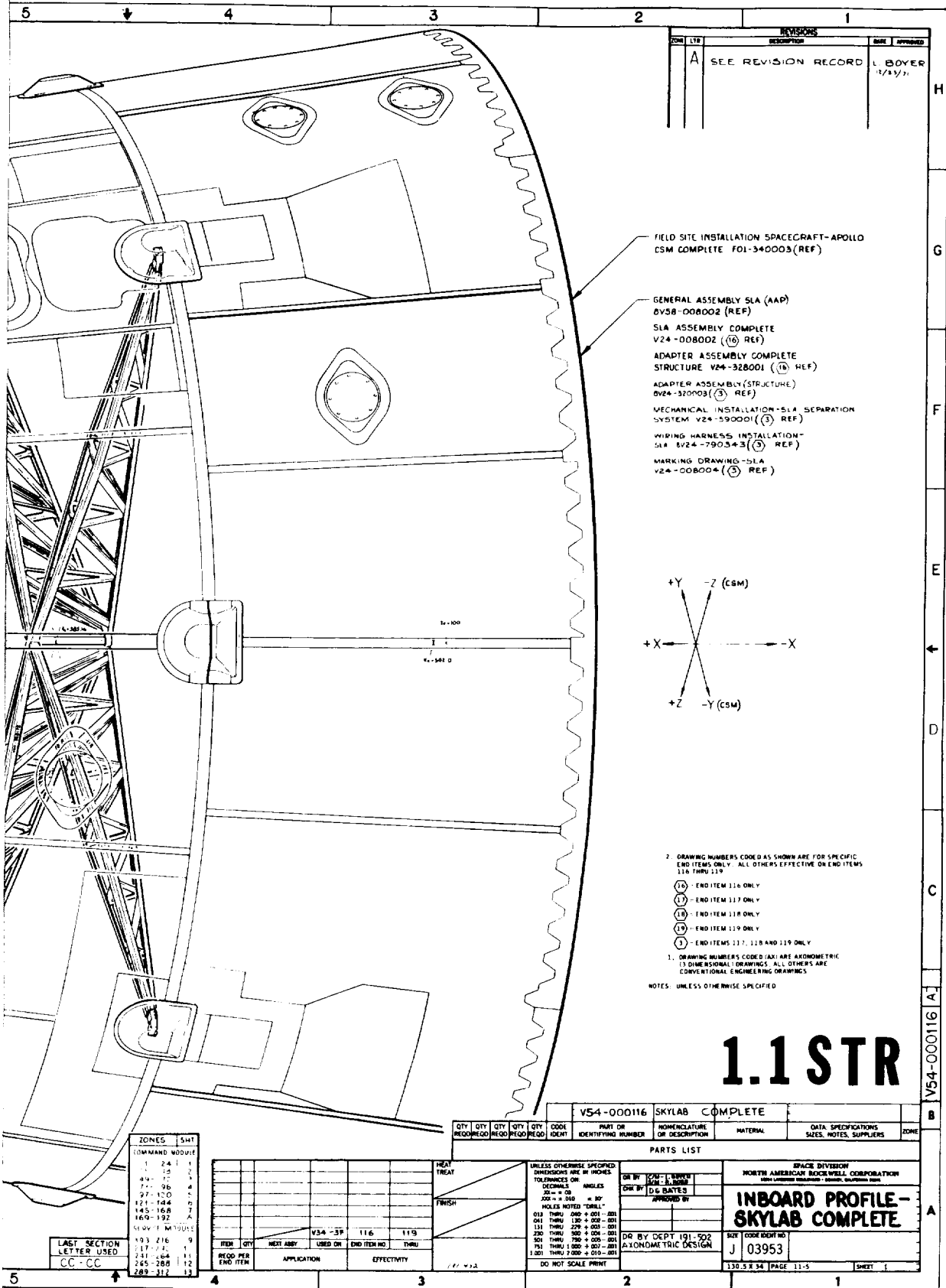

REV	DATE	DESCRIPTION	BY	APPROVED
A		SEE REVISION RECORD	L. BOYER	1/17/77

- FIELD SITE INSTALLATION SPACECRAFT-APOLLO CSM COMPLETE F01-340003 (REF)
- GENERAL ASSEMBLY SLA (AAP) 0V5B-008002 (REF)
- SLA ASSEMBLY COMPLETE V24-008002 (16) (REF)
- ADAPTER ASSEMBLY COMPLETE STRUCTURE V24-328001 (16) (REF)
- ADAPTER ASSEMBLY (STRUCTURE) 0V24-320003 (3) (REF)
- MECHANICAL INSTALLATION-SLA SEPARATION SYSTEM V24-590001 (3) (REF)
- WIRING HARNESS INSTALLATION-SLA 0V24-790343 (3) (REF)
- MARKING DRAWING-SLA V24-008004 (3) (REF)

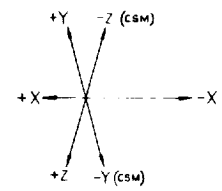

2. DRAWING NUMBERS CODED AS SHOWN ARE FOR SPECIFIC END ITEMS ONLY. ALL OTHERS EFFECTIVE ON END ITEMS 116 THRU 119

- (16) - END ITEM 116 ONLY
- (17) - END ITEM 117 ONLY
- (18) - END ITEM 118 ONLY
- (19) - END ITEM 119 ONLY
- (3) - END ITEMS 117, 118 AND 119 ONLY

1. DRAWING NUMBERS CODED (AX) ARE AXONOMETRIC (3) DIMENSIONAL DRAWINGS. ALL OTHERS ARE CONVENTIONAL ENGINEERING DRAWINGS.

NOTES: UNLESS OTHERWISE SPECIFIED

# 1.1 STR

V54-000116	SKYLAB COMPLETE								
------------	-----------------	--	--	--	--	--	--	--	--

ZONES	SMT
COMMAND MODULE	
1-24	1
25-32	2
33-40	3
41-48	4
49-56	5
57-64	6
65-72	7
73-80	8
81-88	9
89-96	10
97-104	11
105-112	12
113-120	13

ITEM	QTY	NEXT ABBY	USED ON	END ITEM NO	THRU
			V34-59	116	119

QTY	QTY	QTY	QTY	QTY	CODE	PART OR IDENTIFYING NUMBER	NOMENCLATURE OR DESCRIPTION	MATERIAL	DATA SPECIFICATIONS SALES, NOTES, SUPPLIERS	ZONE
RECD	REQD	REQD	REQD	REQD	IDENT					

UNLESS OTHERWISE SPECIFIED DIMENSIONS ARE IN INCHES TOLERANCES ARE: .005" ± .010" .010" ± .015" .015" ± .020" .020" ± .025" .025" ± .030" .030" ± .035" .035" ± .040" .040" ± .045" .045" ± .050" .050" ± .055" .055" ± .060" .060" ± .065" .065" ± .070" .070" ± .075" .075" ± .080" .080" ± .085" .085" ± .090" .090" ± .095" .095" ± .100" .100" ± .105" .105" ± .110" .110" ± .115" .115" ± .120" .120" ± .125" .125" ± .130" .130" ± .135" .135" ± .140" .140" ± .145" .145" ± .150" .150" ± .155" .155" ± .160" .160" ± .165" .165" ± .170" .170" ± .175" .175" ± .180" .180" ± .185" .185" ± .190" .190" ± .195" .195" ± .200" .200" ± .205" .205" ± .210" .210" ± .215" .215" ± .220" .220" ± .225" .225" ± .230" .230" ± .235" .235" ± .240" .240" ± .245" .245" ± .250" .250" ± .255" .255" ± .260" .260" ± .265" .265" ± .270" .270" ± .275" .275" ± .280" .280" ± .285" .285" ± .290" .290" ± .295" .295" ± .300" .300" ± .305" .305" ± .310" .310" ± .315" .315" ± .320" .320" ± .325" .325" ± .330" .330" ± .335" .335" ± .340" .340" ± .345" .345" ± .350" .350" ± .355" .355" ± .360" .360" ± .365" .365" ± .370" .370" ± .375" .375" ± .380" .380" ± .385" .385" ± .390" .390" ± .395" .395" ± .400" .400" ± .405" .405" ± .410" .410" ± .415" .415" ± .420" .420" ± .425" .425" ± .430" .430" ± .435" .435" ± .440" .440" ± .445" .445" ± .450" .450" ± .455" .455" ± .460" .460" ± .465" .465" ± .470" .470" ± .475" .475" ± .480" .480" ± .485" .485" ± .490" .490" ± .495" .495" ± .500" .500" ± .505" .505" ± .510" .510" ± .515" .515" ± .520" .520" ± .525" .525" ± .530" .530" ± .535" .535" ± .540" .540" ± .545" .545" ± .550" .550" ± .555" .555" ± .560" .560" ± .565" .565" ± .570" .570" ± .575" .575" ± .580" .580" ± .585" .585" ± .590" .590" ± .595" .595" ± .600" .600" ± .605" .605" ± .610" .610" ± .615" .615" ± .620" .620" ± .625" .625" ± .630" .630" ± .635" .635" ± .640" .640" ± .645" .645" ± .650" .650" ± .655" .655" ± .660" .660" ± .665" .665" ± .670" .670" ± .675" .675" ± .680" .680" ± .685" .685" ± .690" .690" ± .695" .695" ± .700" .700" ± .705" .705" ± .710" .710" ± .715" .715" ± .720" .720" ± .725" .725" ± .730" .730" ± .735" .735" ± .740" .740" ± .745" .745" ± .750" .750" ± .755" .755" ± .760" .760" ± .765" .765" ± .770" .770" ± .775" .775" ± .780" .780" ± .785" .785" ± .790" .790" ± .795" .795" ± .800" .800" ± .805" .805" ± .810" .810" ± .815" .815" ± .820" .820" ± .825" .825" ± .830" .830" ± .835" .835" ± .840" .840" ± .845" .845" ± .850" .850" ± .855" .855" ± .860" .860" ± .865" .865" ± .870" .870" ± .875" .875" ± .880" .880" ± .885" .885" ± .890" .890" ± .895" .895" ± .900" .900" ± .905" .905" ± .910" .910" ± .915" .915" ± .920" .920" ± .925" .925" ± .930" .930" ± .935" .935" ± .940" .940" ± .945" .945" ± .950" .950" ± .955" .955" ± .960" .960" ± .965" .965" ± .970" .970" ± .975" .975" ± .980" .980" ± .985" .985" ± .990" .990" ± .995" .995" ± 1.000

DO NOT SCALE PRINT

SPACE DIVISION NORTH AMERICAN ROCKWELL CORPORATION 2000 LINDEN BLVD. TORRANCE, CALIFORNIA 90503

DR BY DEPT 191-592 AXONOMETRIC DESIGN

SEE CODE BOOK NO. J 03953

130.5 X 34 PAGE 11-5 SHEET 1



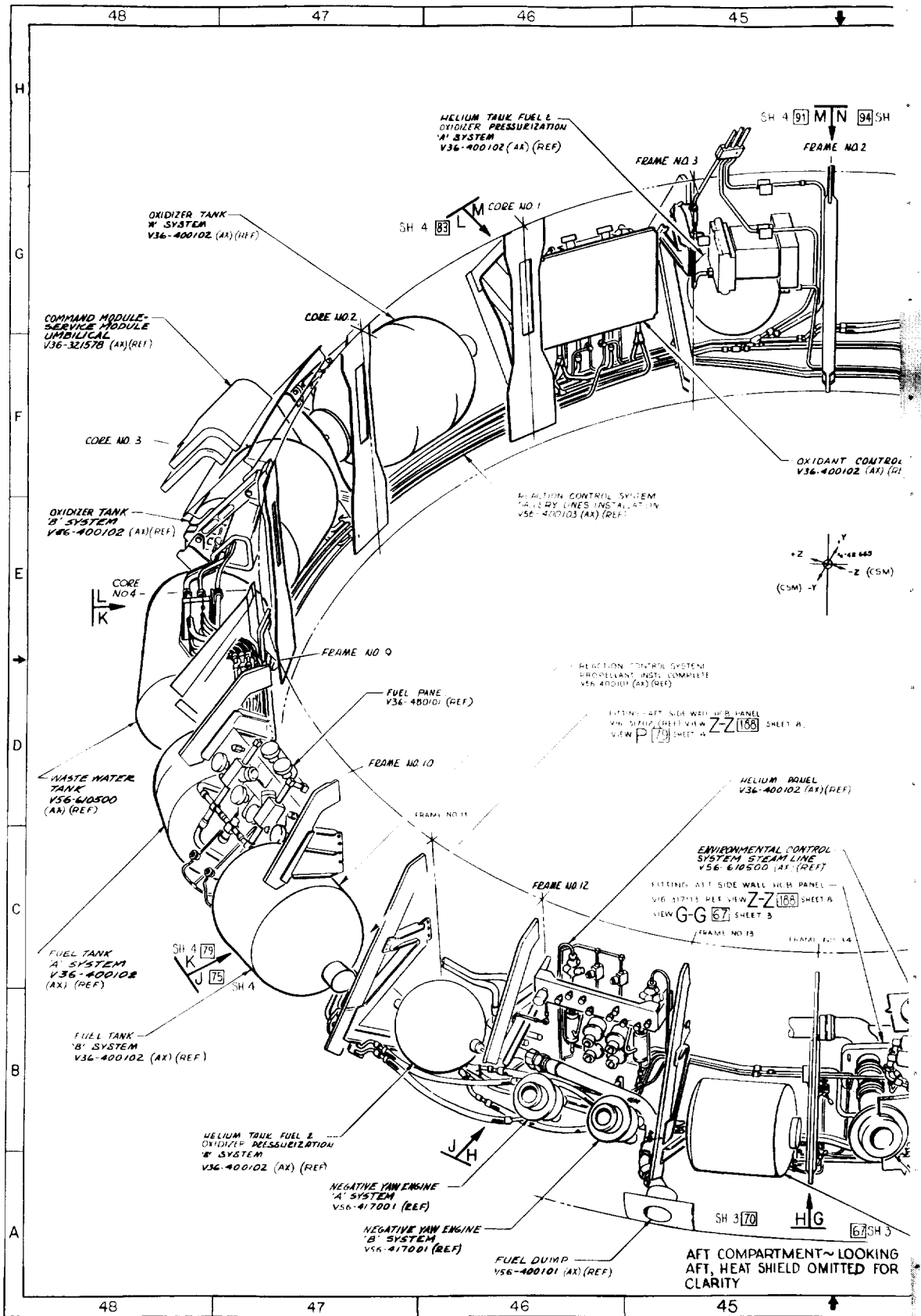

**FOLDOUT FRAME**



V36-751521 (REF)

CS02207  
TEMP LOCKING  
PROBE CYLINDER  
V0010-7700EKT

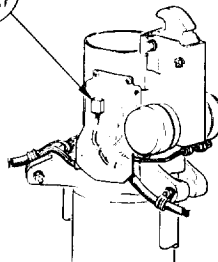

VIEW B 37  
ROTATED 135° CCW

INSULATION II  
CREW COMPART  
V56-321400

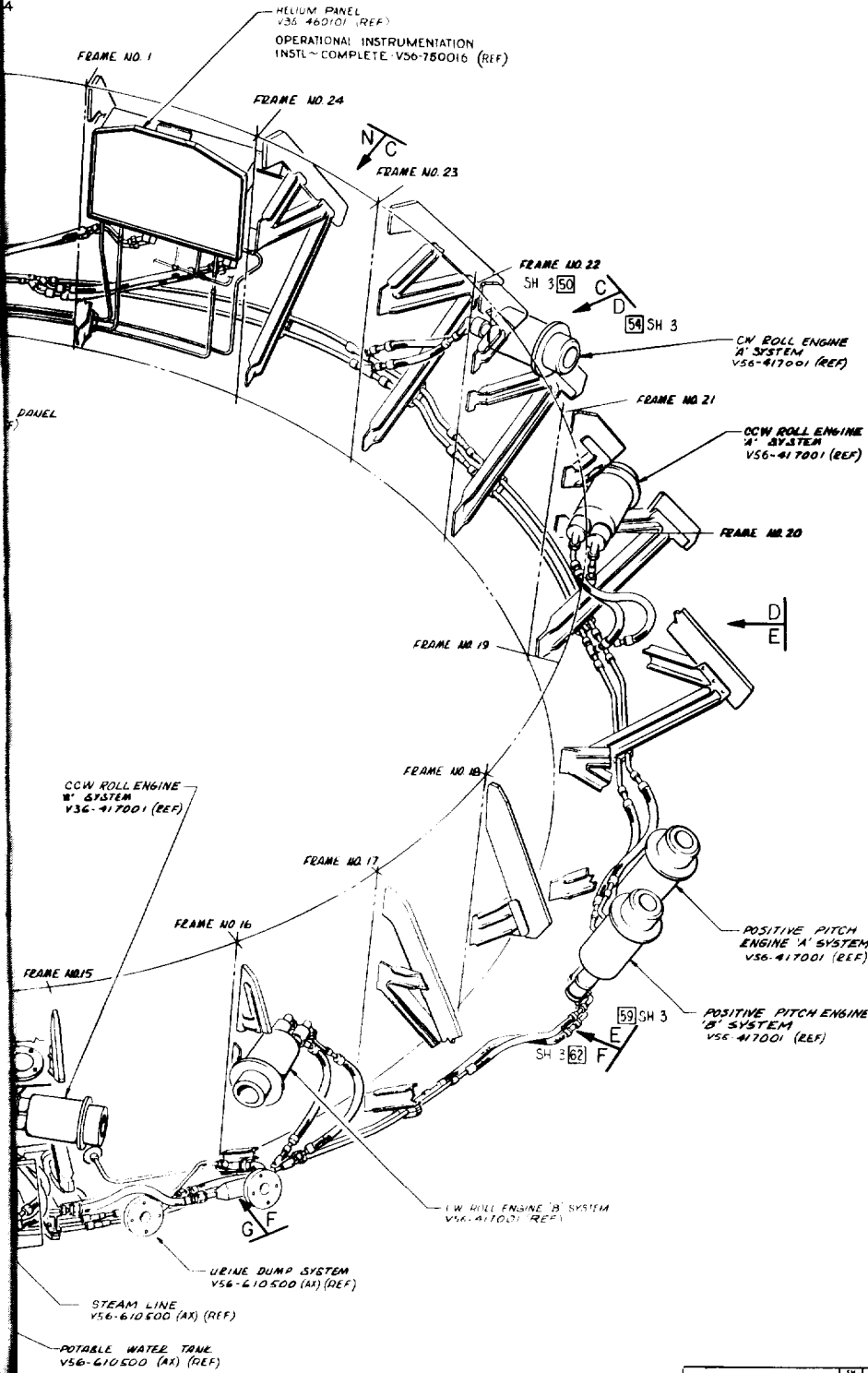

REV	2
BY	A





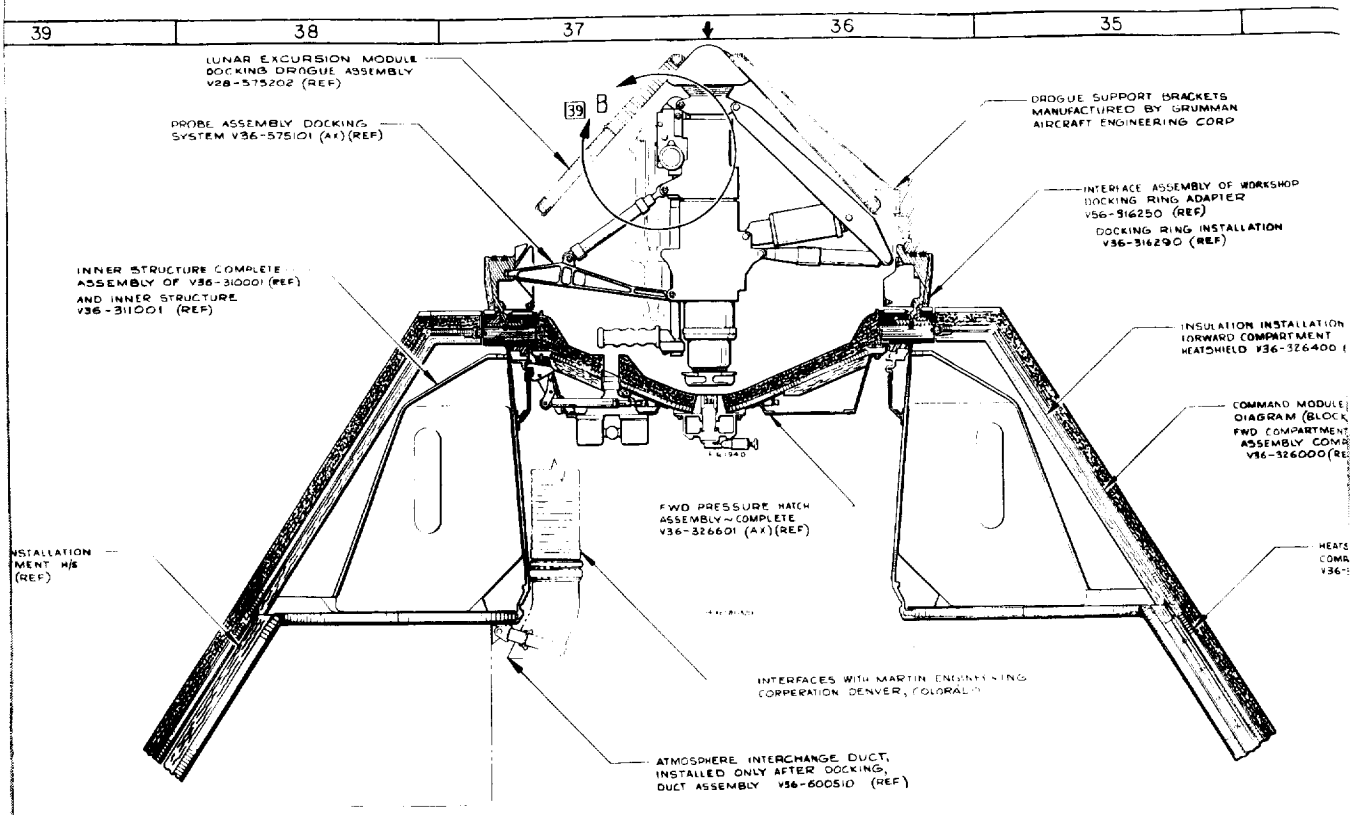

SCHEMATIC CROSS SECTION OF TUNNEL AREA COMMAND MODULE

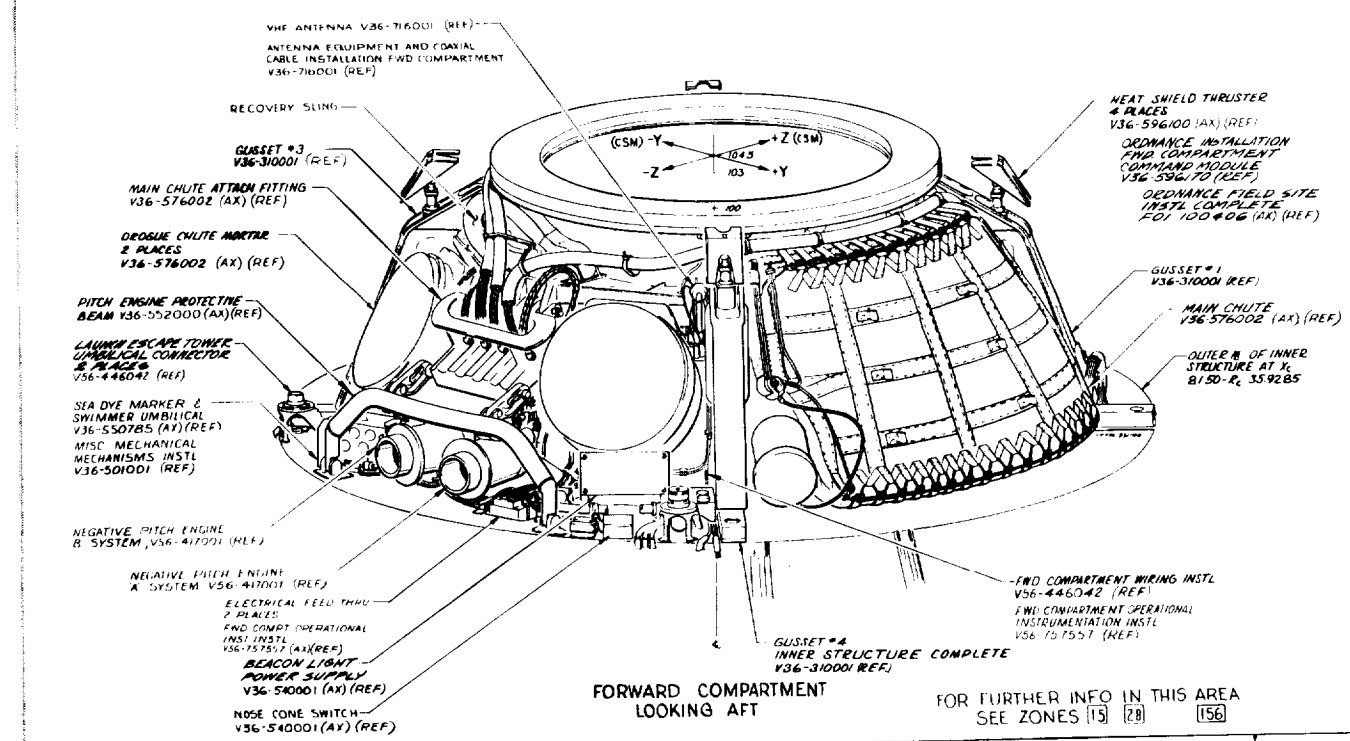



REF)

HEAT SHIELD STRUCTURE  
 (L) V36-932003 (REF)  
 HEAT SHIELD  
 LITE  
 7)

HEAT SHIELD ASSEMBLY CREW  
 COMPARTMENT COMPLETE  
 21000 (REF)

BONDED INNER STRUCTURE ASSY  
 Xc 2 B0 TO Xc 10# 30  
 Y36-31000# (REF)

HEAT SHIELD THRUSTER  
 4 PLACES  
 Y36-896100 (AX) (REF)

THRUSTER BREECH  
 Y36-896100 (AX) (REF)

INVD COMPARTMENT  
 WIRING (KSTL)  
 Y56-#6042 (REF)

GUSSET #4  
 Y36-31000 (REF)

REACTION CONTROL SYS  
 INVD COMPT  
 Y56-400101 (REF)

GUSSET #1

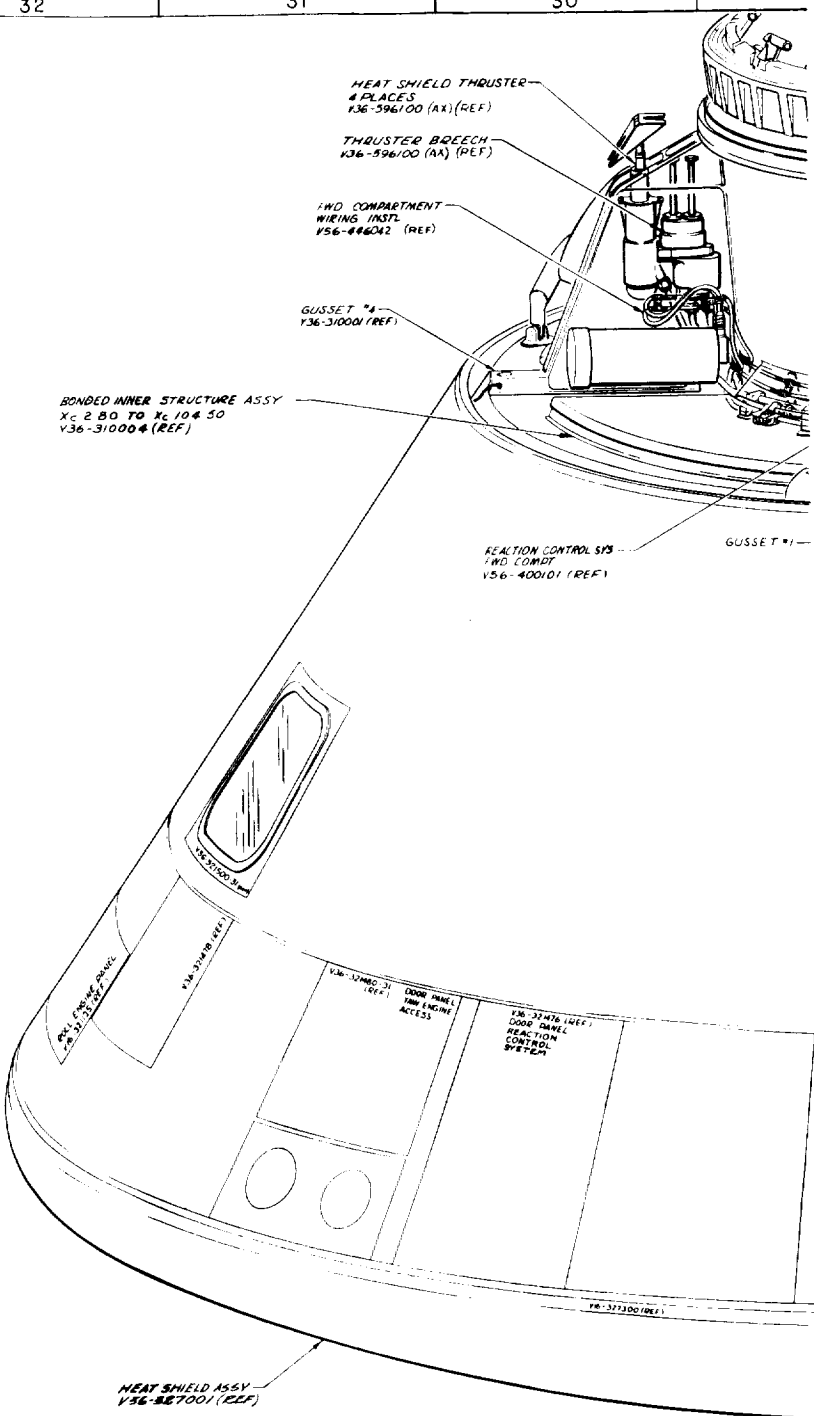

HEAT SHIELD ASSY  
 Y36-887001 (REF)

-Z  
 +Y  
 C

REV  
 2 A



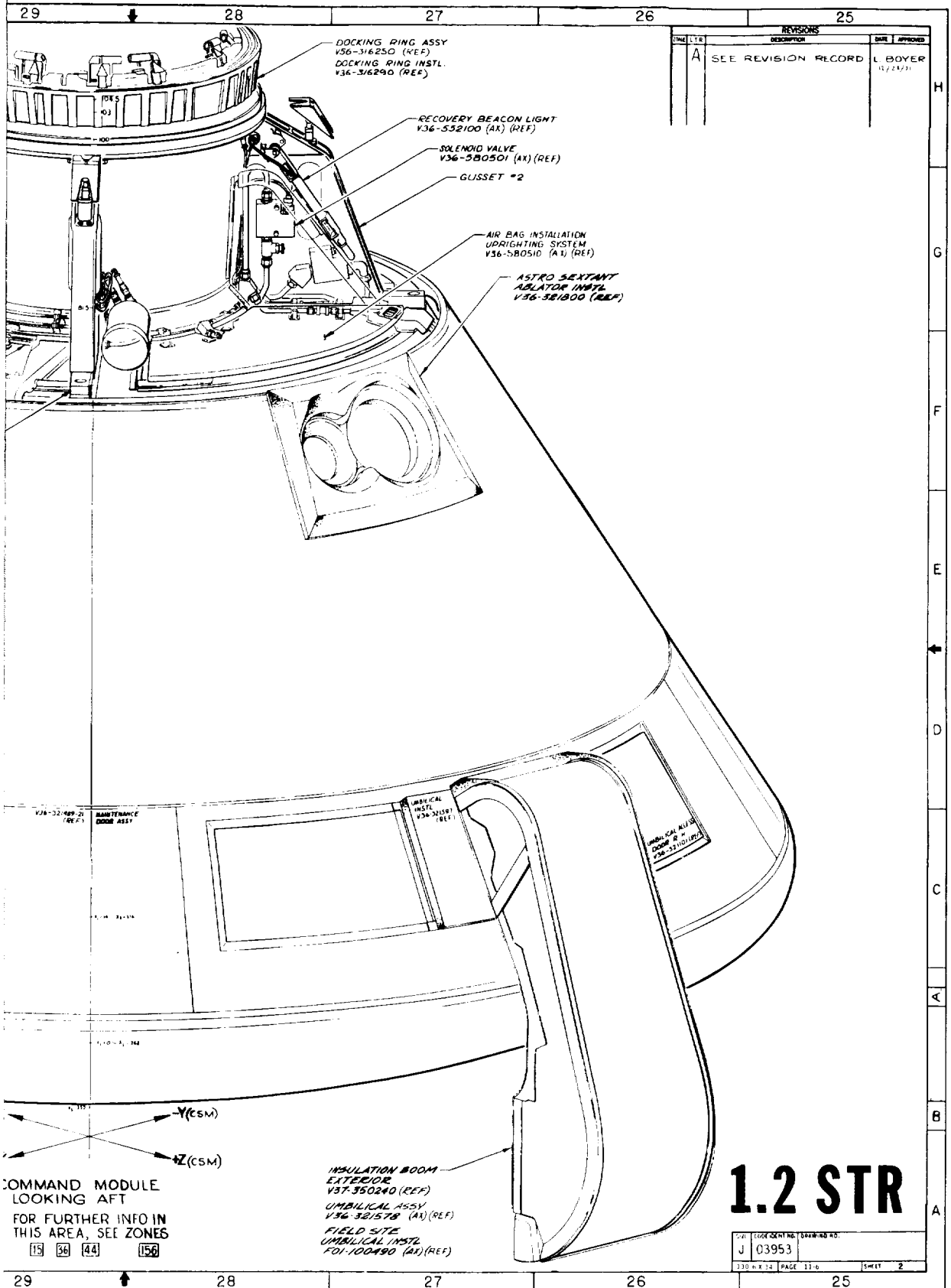

FOLDOUT FRAME 5



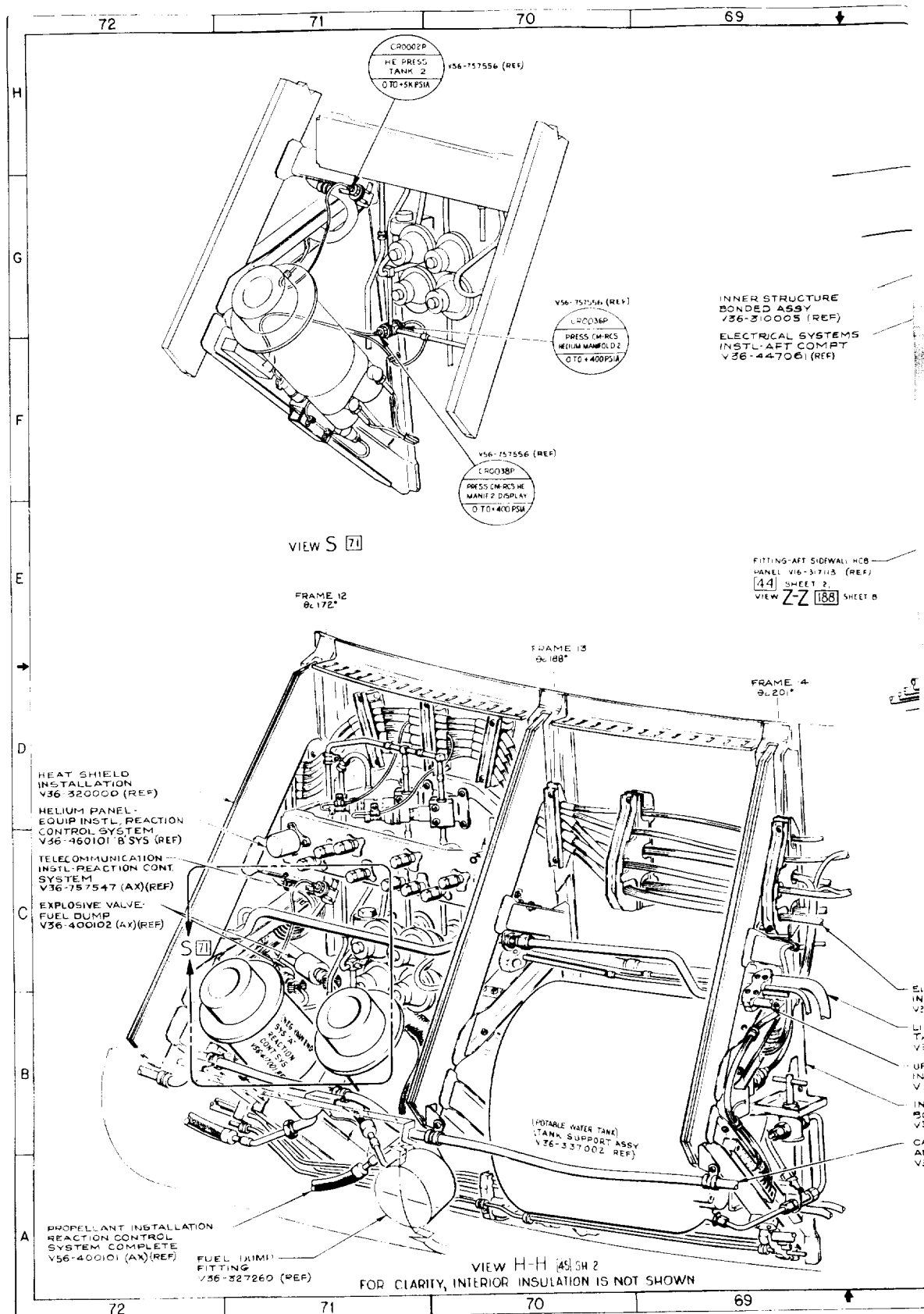

**FOLDOUT FRAME**

1188



68

67

66

65

64

CONTINUED ON FWD  
COMPT DWG  
V56-446042

FRAME 16  
Ø. 231'30"

FRAME 15  
Ø. 214"

FRAME 14  
Ø. 201"

HEAT SHIELD  
INSTALLATION  
V36-320000 (REF)  
CW ROLL ENGINE INSTL  
SYSTEM 'B' REACTION  
CONTROL SYSTEM  
V56-417001 (REF)  
REACTION CONTROL  
SYS COMPLETE  
V56-400101 (AX)(REF)  
UPRIGHTING EQUIP  
INSTALLATION  
V36-580501  
(AX)(REF)

INSTRUMENTATION  
AFT COMPARTMENT  
V36-757556 (AX) (REF)

V36-757542 (REF)

Ø. 04611  
TEMP WASTE WATER  
DUMP NOZZLE  
Ø. 1000066

V-BAND ANTENNA  
CABLE INSTALLATION  
ANTENNA EQUIP  
V36-717001 (AX) (REF)

V36-757562 (REF)  
Ø. 04611  
TEMP WASTE  
DUMP NOZZLE  
Ø. 1000066

FRAME 16  
Ø. 231'30"

PAD 4  
AFT HEAT SHIELD  
V36-327000 (REF)  
LINES INSTL-REACTION  
CONTROL SYSTEM  
V56-400103 (AX)(REF)

URINE DUMP NOZZLE  
STEAM VENT  
LINES, DUCT & WATER  
TANK INSTL-AFT COMPT  
V36-610500 (AX)(REF)

VIEW G-G ~~44~~ SH 2  
FOR CLARITY, INTERIOR  
INSULATION IS NOT SHOWN

ELECTRICAL SYS  
INSTL-AFT COMPT  
V26-447061 (REF)  
CW ROLL ENGINE INSTL  
SYSTEM 'B' REACTION  
CONTROL SYSTEM  
V56-417001 (REF)  
INSTRUMENTATION INSTL  
AFT COMPT  
V36-757556 (AX) (REF)

UPRIGHTING EQUIP  
INSTALLATION  
V36-580501 (AX)(REF)  
INNER STRUCTURE  
BONDED ASSY  
V36-310005 (REF)

ELECTRICAL SYSTEMS  
INSTL-AFT COMPT  
V26-447061 (REF)  
LINES, DUCT & WATER  
TANK INSTL-AFT COMPT  
V36-610500 (AX)(REF)  
UPRIGHTING EQUIPMENT  
INSTALLATION  
V36-580501 (AX) (REF)  
INNER STRUCTURE  
BONDED ASSY  
V36-310005 (REF)  
V-BAND ANTENNA  
CABLE INSTALLATION  
ANTENNA EQUIP  
V36-717001 (AX)(REF)

68

67

66

65

64

EXPLODED FRAME 2



63

62

61

60

59

FR  
0c

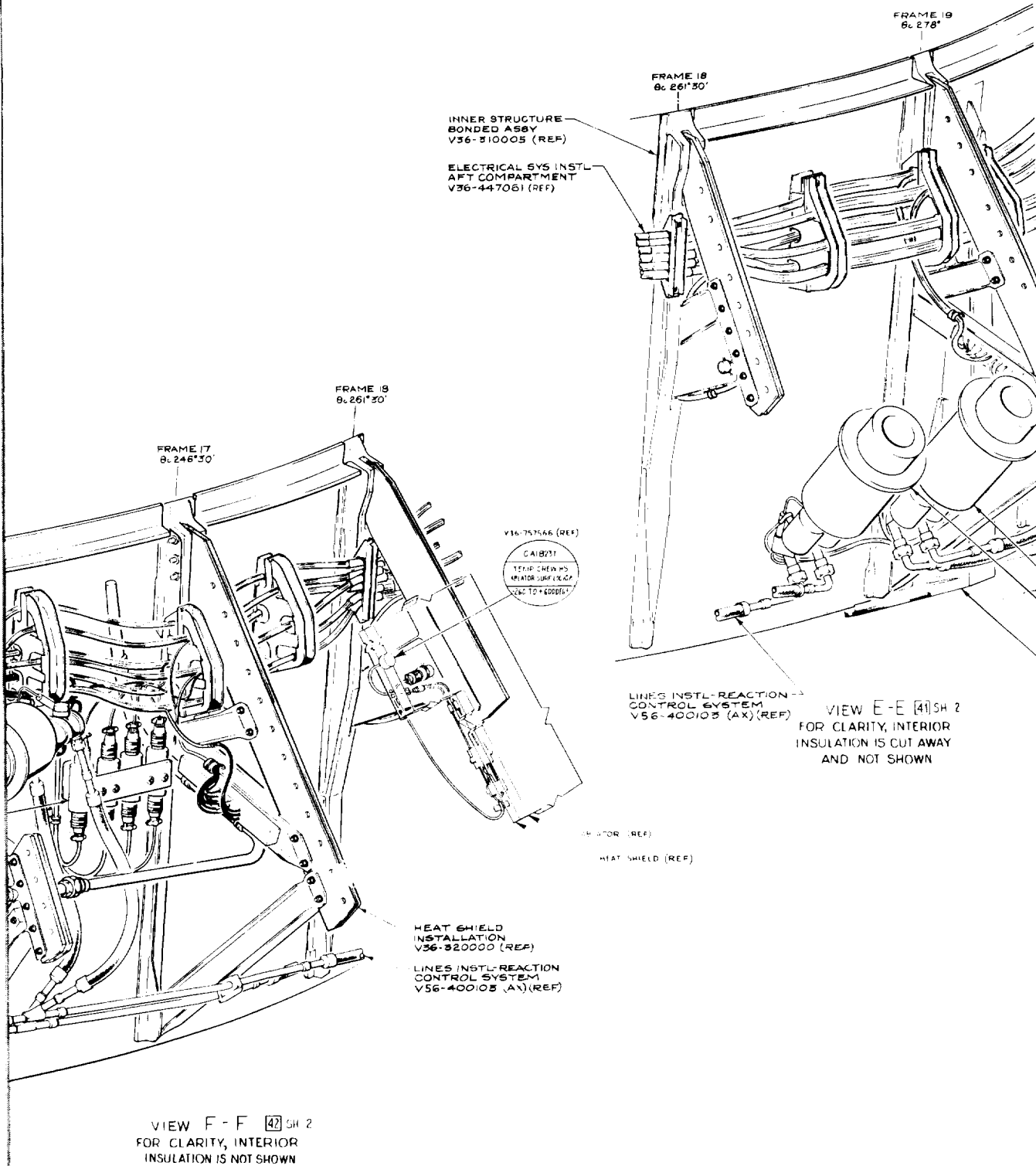

63

62

61

60

59

FOLDOUT FRAME 3



58

57

56

55

54

ME 20  
Ø 294"

INSULATION  
INSTALLATION  
V36-321400 (REF)

HEAT SHIELD  
INSTALLATION  
V36-320000 (REF)

AIR VENT  
INSTALLATION  
V16-321404 (REF)

INNER STRUC:  
BONDED ASSY  
V36-310005

ELECTRICAL S  
AFT COMPART  
V36-447061 (I)

INSTRUMENT  
AFT COMPAR  
V36-757556

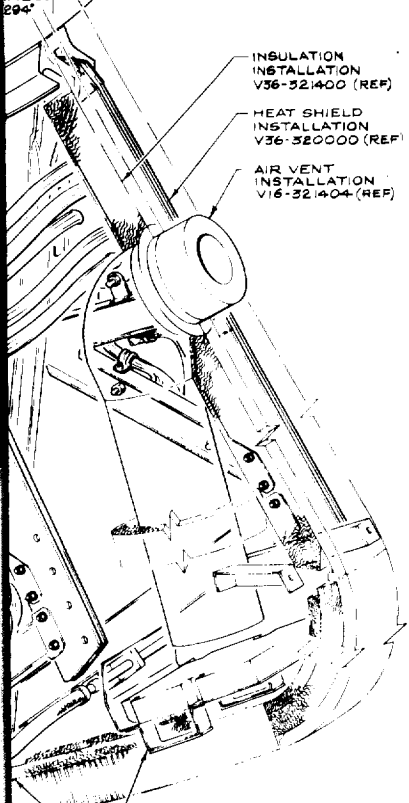

CONTINUED ON FWD COMPT  
DWG V56-446042

FRAME 22  
Ø 326"

ELECTRICAL SYS INSTL  
AFT COMPARTMENT  
V36-447061 (REF)

FRAME 21  
Ø 308"30

FRAME 20  
Ø 294"

HEAT SINK ASSY  
V36-327253 (REF)

INSULATION INSTL  
V16-327402 (REF)

POS. PITCH ENG  
SYSTEM "A"

POS. PITCH ENG  
SYSTEM "B"

REACTION CONTROL  
SYSTEM COMPLETE  
V56-400101 (AX) (REF)

TENSION TIE 3

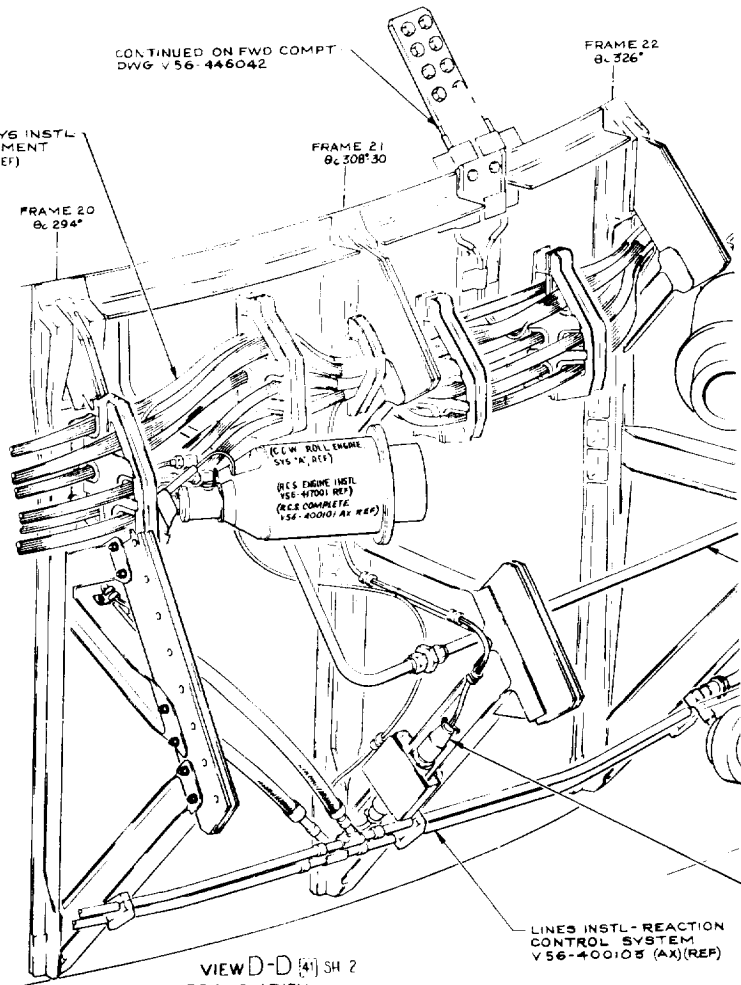

VIEW D-D (4) SH 2  
FOR CLARITY,  
INTERIOR INSULATION  
IS NOT SHOWN

LINES INSTL- REACTION  
CONTROL SYSTEM  
V56-400105 (AX) (REF)

58

57

56

55

54

**FOLDOUT FRAME 4**



REVISIONS		DATE	APPROVED
A	SEE REVISION RECORD		L. BOYER 1/15/72

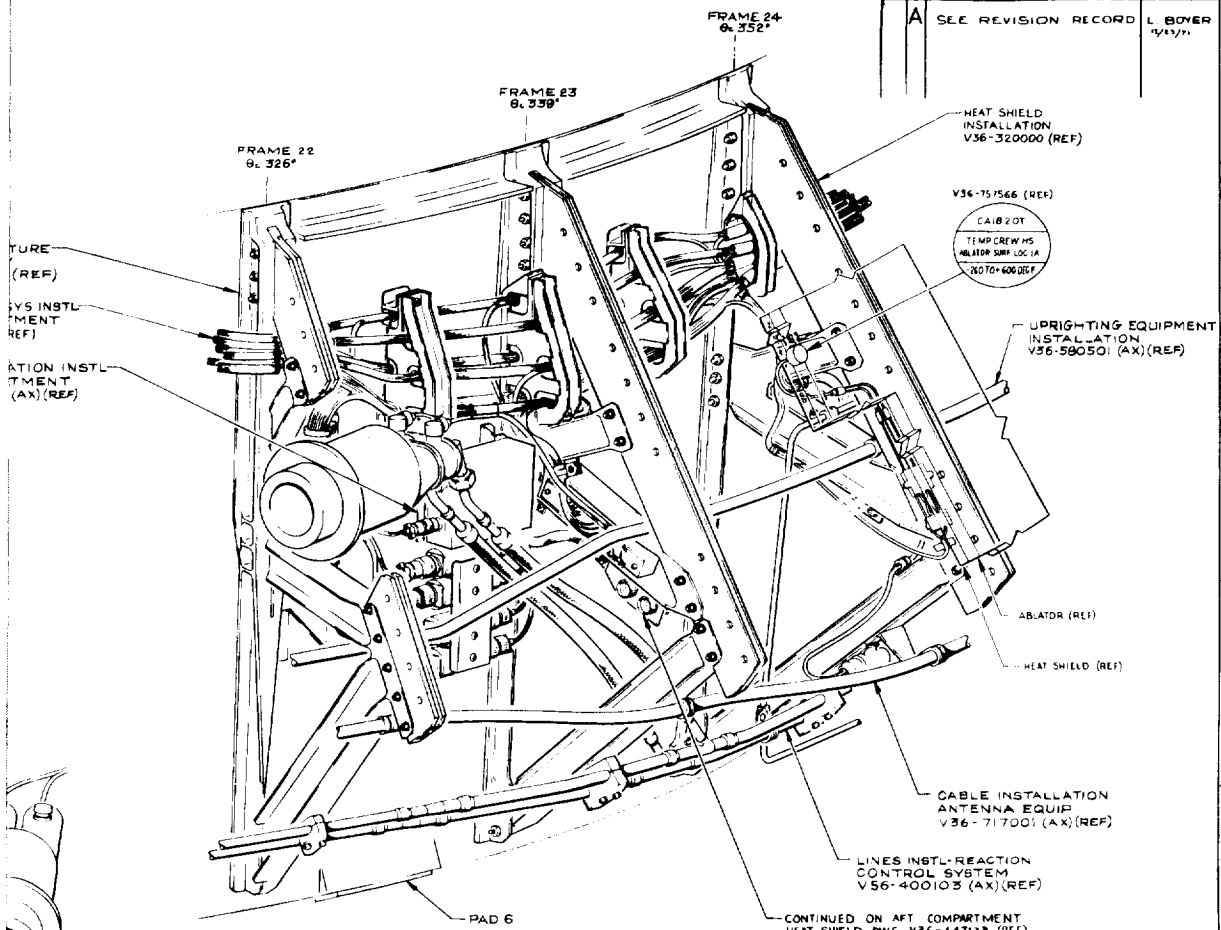

VIEW C-C (A) SH 2  
FOR CLARITY,  
INTERIOR INSULATION  
IS NOT SHOWN

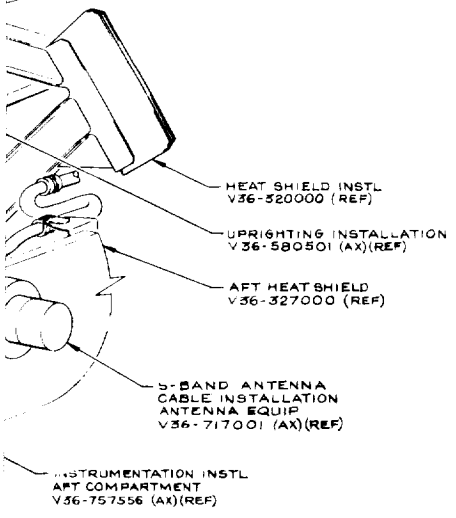

**1.3 STR**

SIZE	CODE	CONT NO	DRAWING NO
J	03953		
130 X 34	PAGE	11-7	DWG

**EQLDOUT FRAME 5**





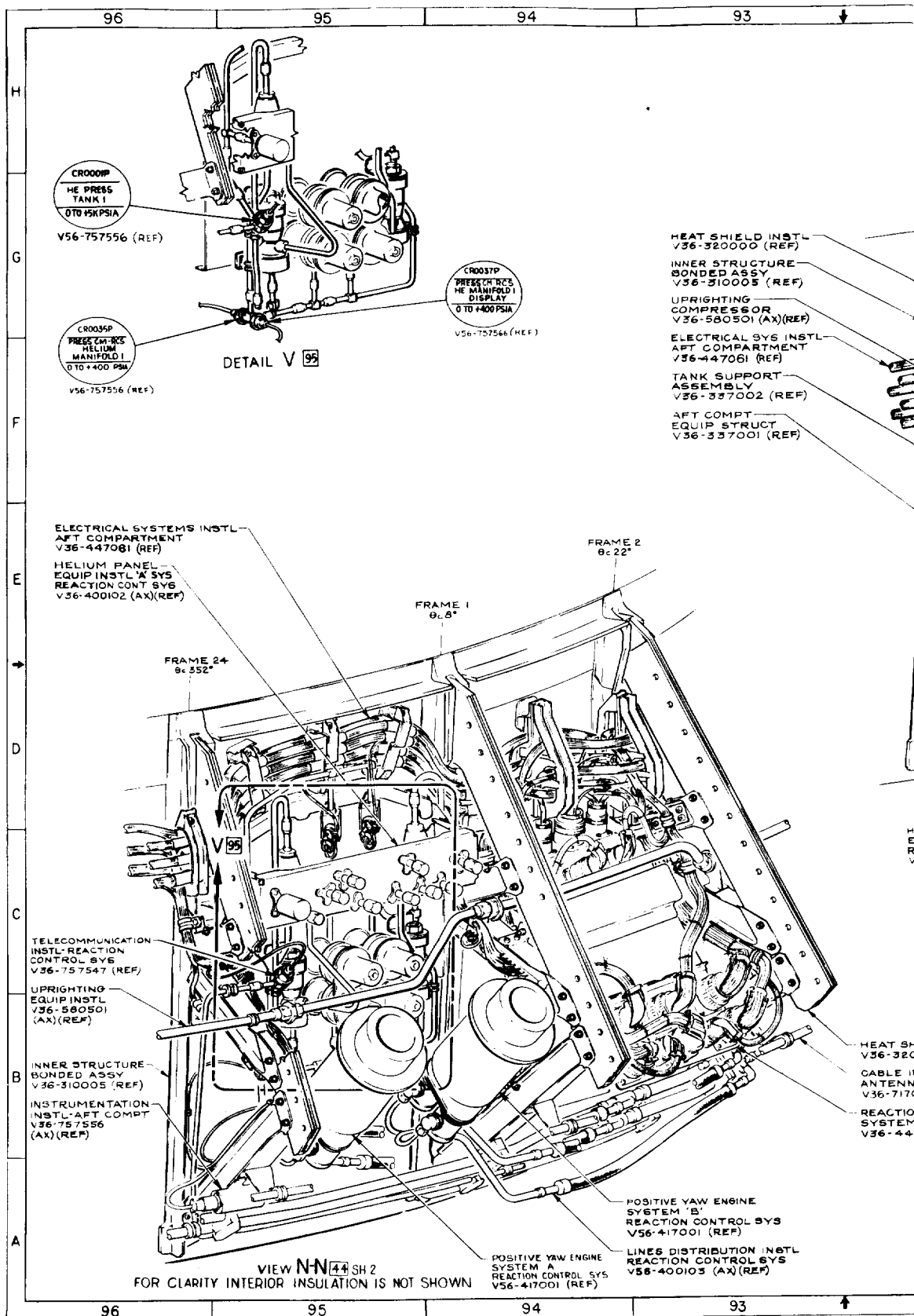

**FOLDOUT FRAME 1**

11/11/2020

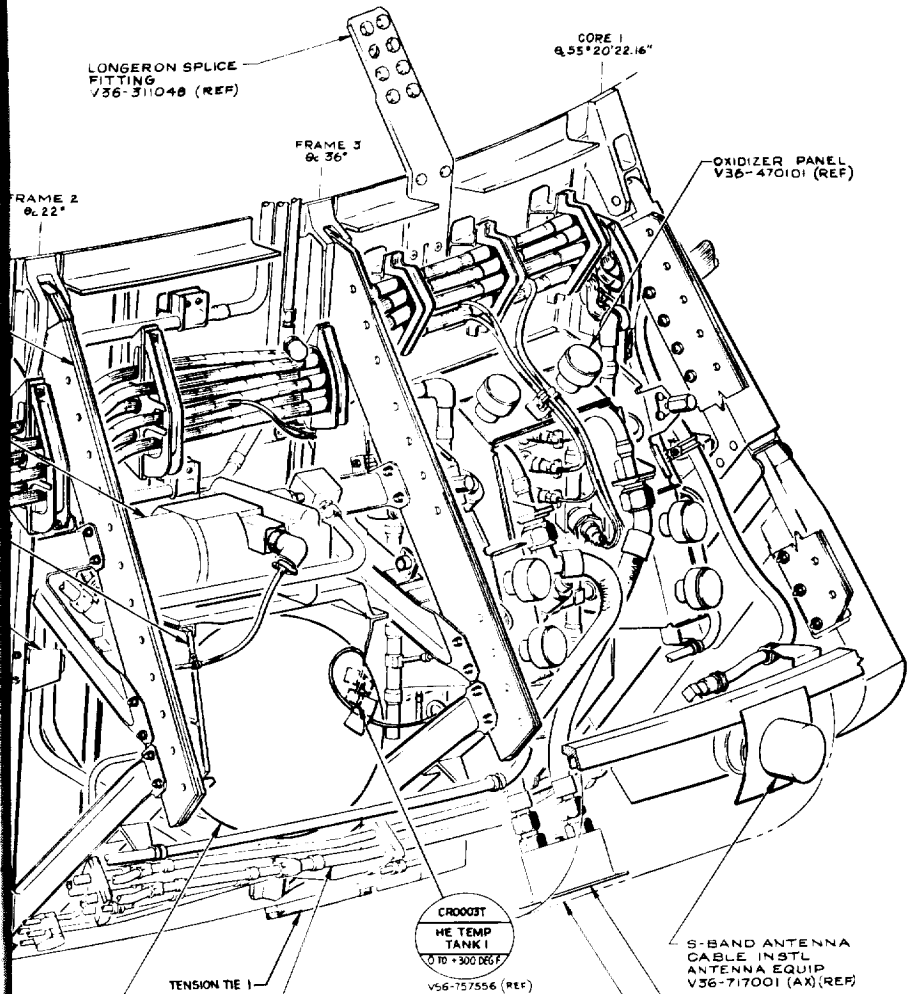

VIEW M-M 3 SH 2 FOR CLARITY, INTERIOR INSULATION IS NOT SHOWN

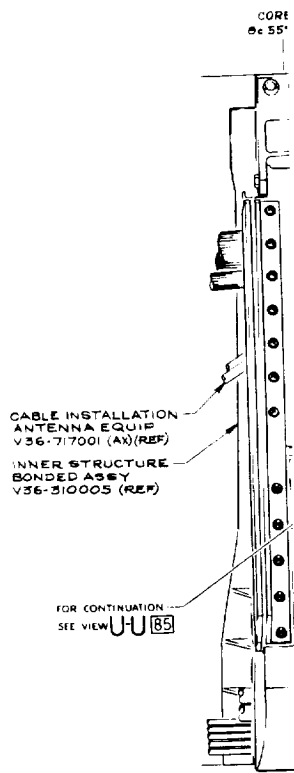

LD INSTL DO (REF)

INSTALLATION EQUIP (AX)(REF)

CONTROL OX 80 (REF)

REV	3	3	1
-----	---	---	---

EXPLODED FRAME 2



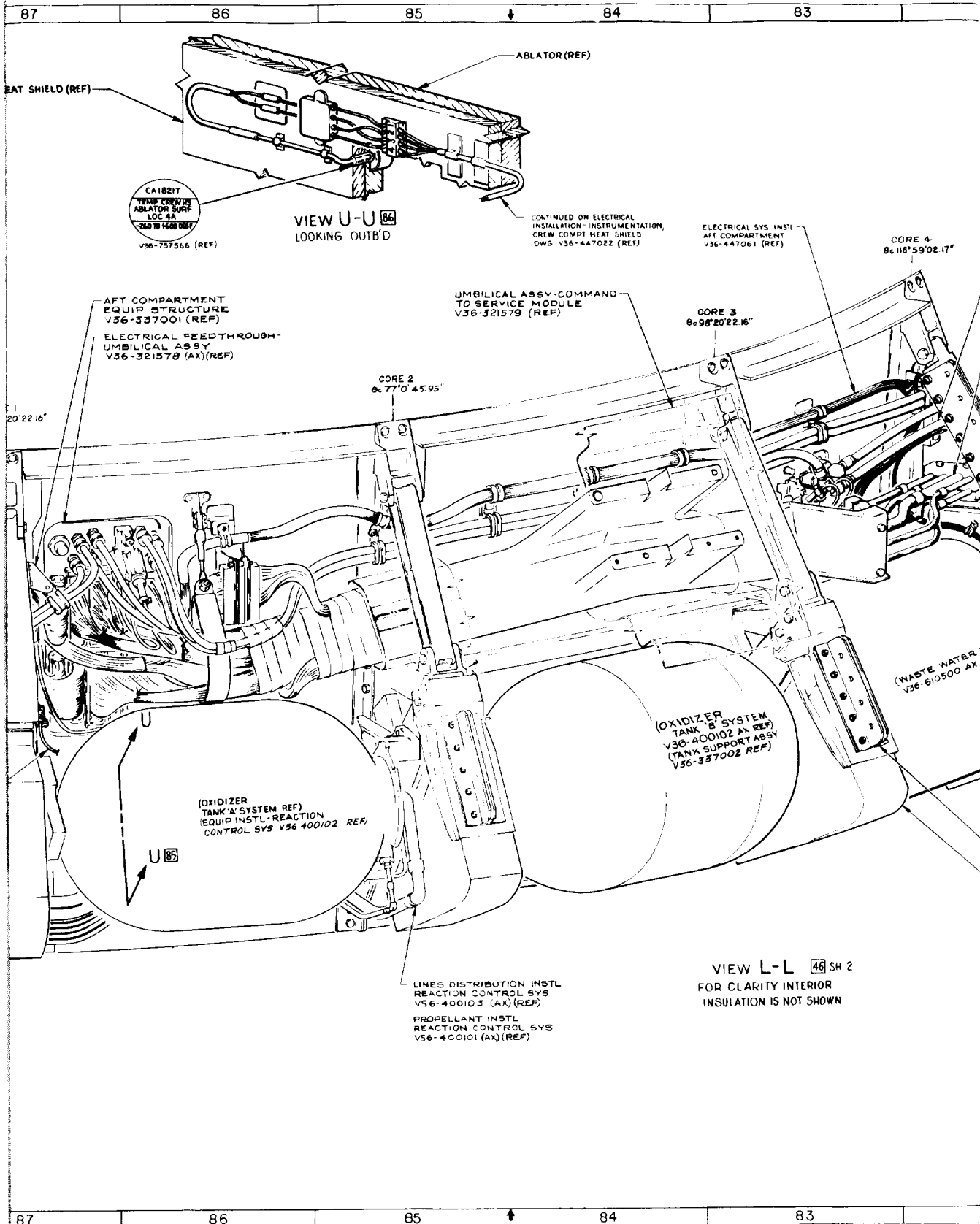

FOLDOUT FRAME 3



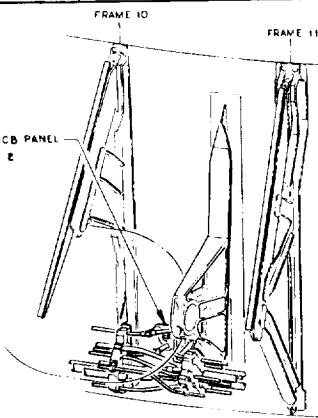

INNER STRUC  
BONDED ASSY  
V36-31000E (REF)

UPRIGHTING  
INSTALLATI  
V36-58050

VIEW P 77  
FOR CLARITY RCS LINES  
ARE NOT SHOWN

CABLE INSTALLATION  
ANTENNA EQUIP  
V36-71700I (AX)(REF)

LINES DUCT WATER  
TANK INSTL AFT COMPT  
V36-610500 (AX)(REF)

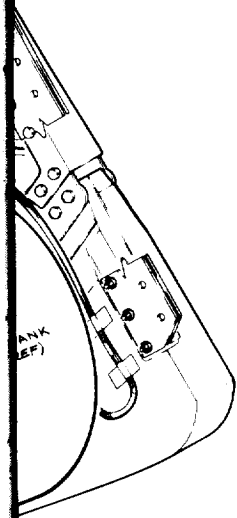

INNER STRUCTURE  
COMPONENTS ASSY  
V36-31000E (REF)

INNER STRUCTURE  
BONDED ASSY  
V36-31000E (REF)  
UPRIGHTING EQUIP  
INSTALLATION  
V36-58050I (AX)(REF)  
HEAT SHIELD  
INSTALLATION  
V36-320000 (REF)  
FUEL CONTROL PANEL  
V36-48010I (REF)  
CABLE INSTALLATION  
ANTENNA EQUIP  
V36-71700I (AX)(REF)

CORE 4  
8c116°59'02.17"

FRAME 9  
8c126°

FRAME 10  
8c144°

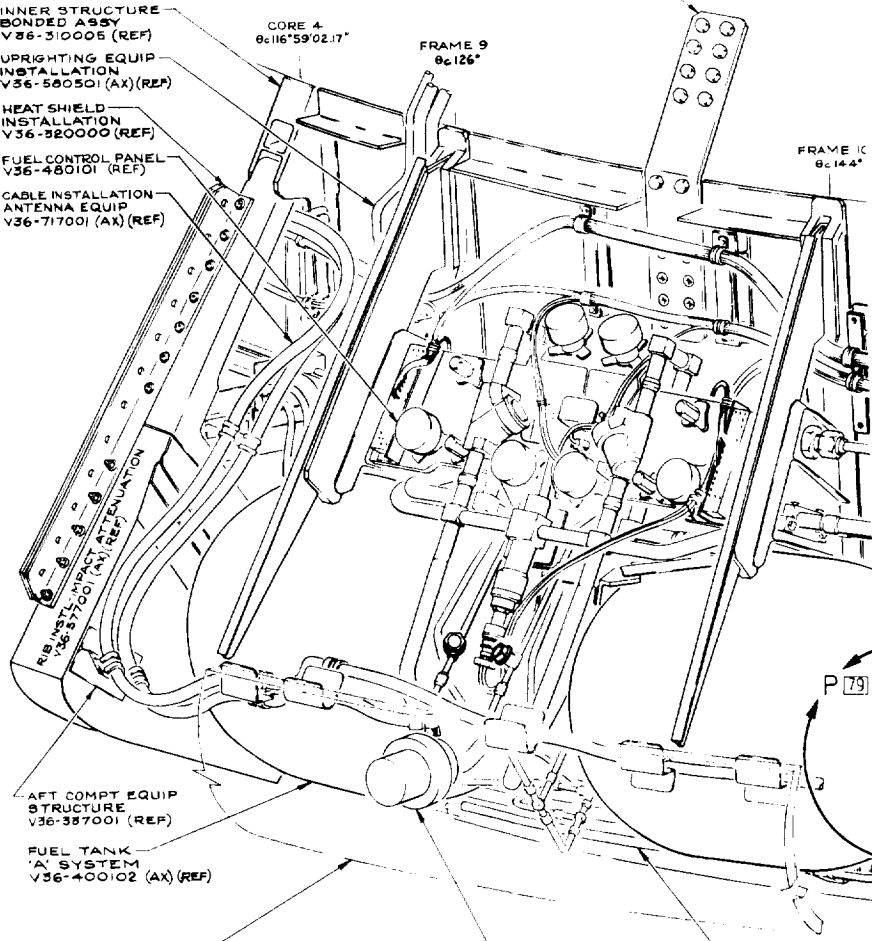

HEAT SHIELD  
INSTALLATION  
V36-320000 (REF)  
RIB INSTALLATION  
IMPACT ATTENUATION  
V36-57700I (AX)(REF)

AFT COMPT EQUIP  
STRUCTURE  
V36-38700I (REF)

FUEL TANK  
"A" SYSTEM  
V36-400102 (AX)(REF)

AFT HEAT SHIELD  
V36-327000 (REF)

VIEW K-K 48 SH 2  
FOR CLARITY, INTERIOR  
INSULATION IS NOT SHOWN

S-BAND ANTENNA-  
CABLE INSTALLATION  
ANTENNA EQUIP  
V36-71700I (AX)(REF)

LINES DIST INST  
REACTION CONT  
V36-400103 (A)

FOLDOUT FRAME 4





REVISONS		DATE	APPROVED
REV	DESCRIPTION		
A	SEE REVISION RECORD	11/21/74	L. BOYER

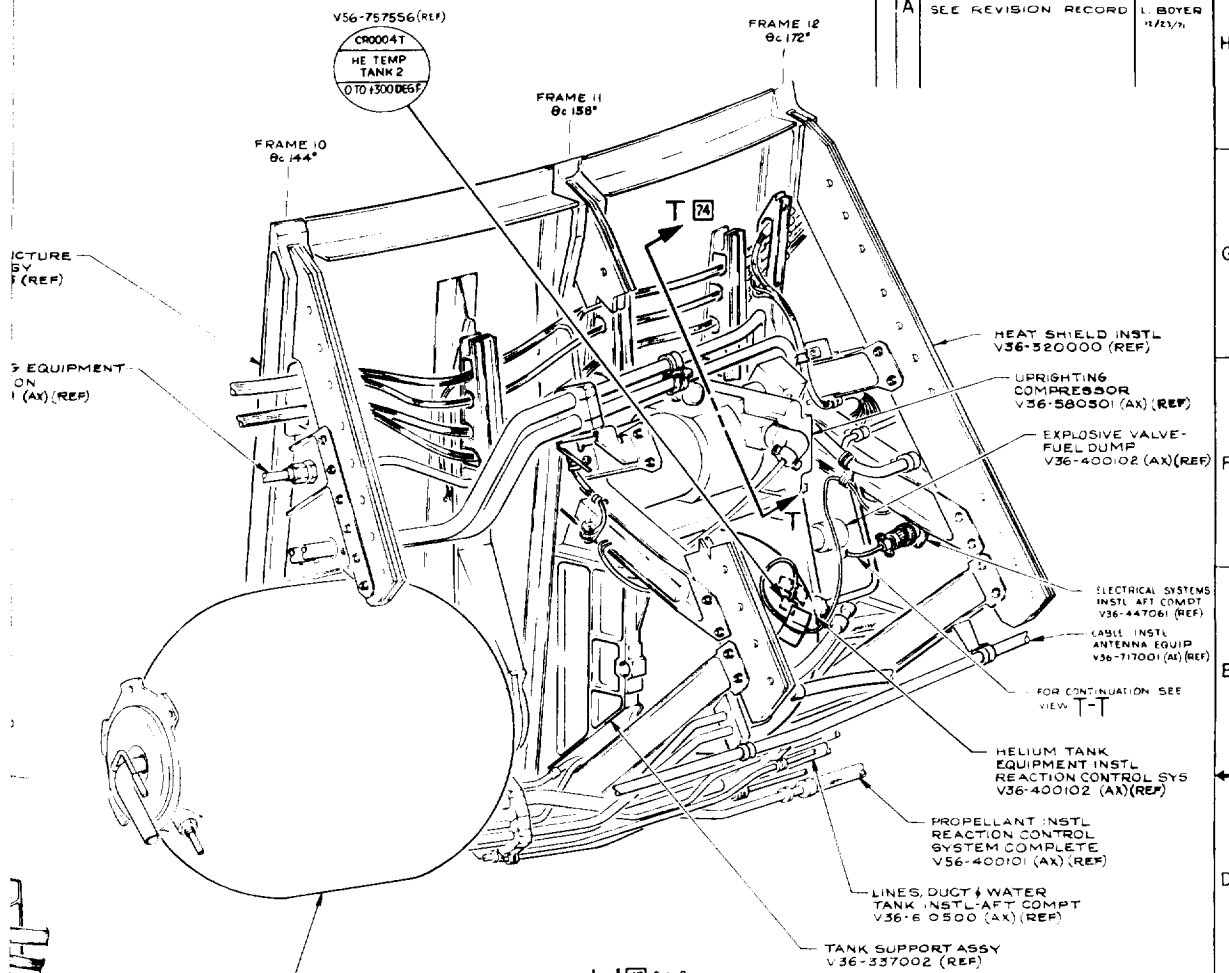

VIEW J-J 74 SH 2  
 FOR CLARITY,  
 INTERIOR INSULATION  
 IS NOT SHOWN

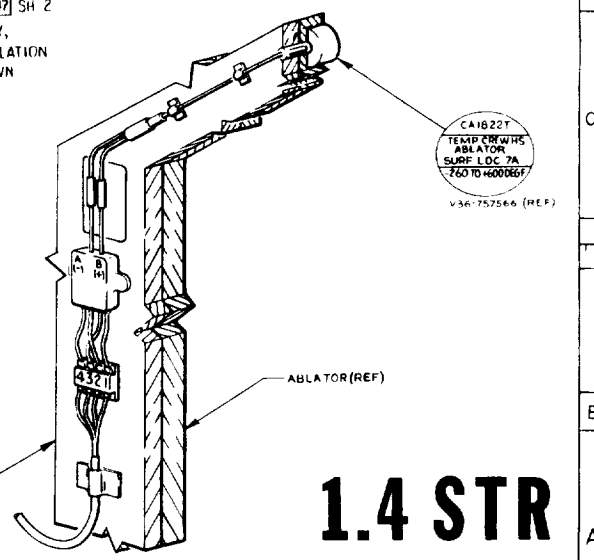
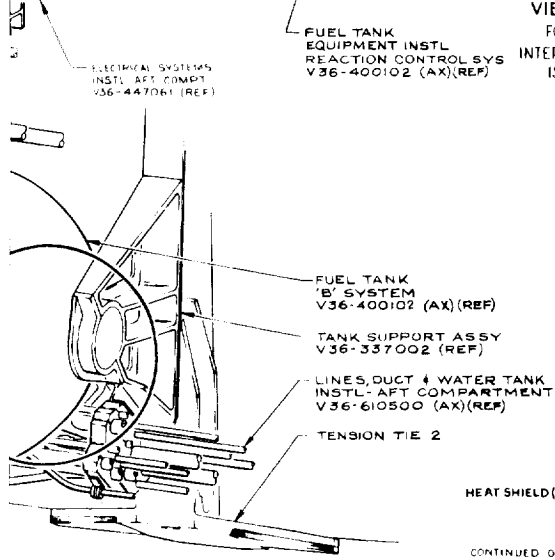

**1.4 STR**

CONTINUED ON ELECTRICAL  
 INSTALLATION-INSTRUMENTATION  
 CREW COMPMT HEAT SHIELD  
 DWG V36-447022 (REF)

VIEW T-T 74  
 LOOKING OUT B D

REV	DESCRIPTION	DATE	APPROVED
J	03953		

130 X 14 PAGE 118 SHEET

FOLDOUT FRAME 5



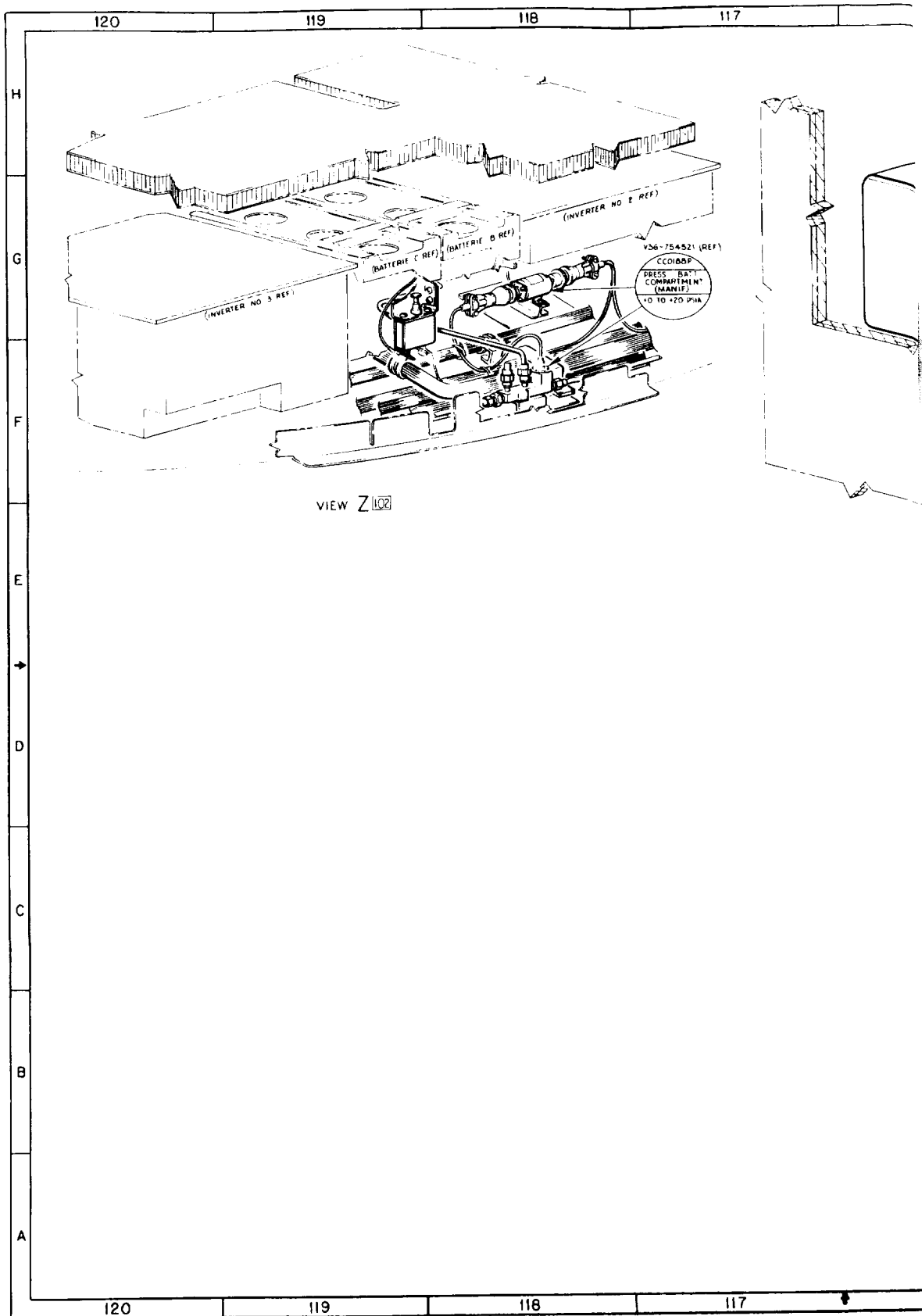

FOLDOUT FRAME /



116

115

114

113

112

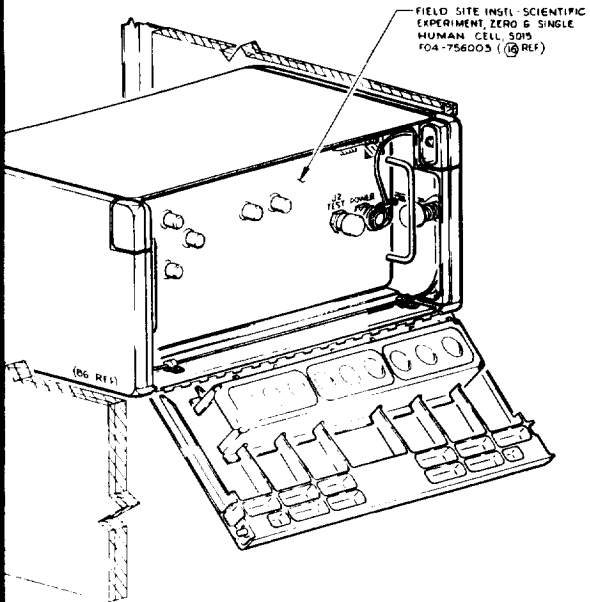

FIELD SITE INSTL-SCIENTIFIC  
EXPERIMENT ZERO 6 SINGLE  
HUMAN CELL 5015  
FO4-756005 (10) REF)

LOWER EQUIP BAY, D+C  
INSTALLATION V56-764000  
(REF)

GUIDANCE AND NAVIGATION EQUIP INSTL  
LOWER EQUIP BAY V36-72400T (REF)

STRUCTURE-LOWER EQUIPMENT BAY  
Xc-42.645 TO Xc-80.75  
V36-334501 (REF)

RETAINERS-EQUIPMENT, CREW  
COMPARTMENT INTERIOR,  
INSTALLATION OF  
(SEE RETAINER DWG NO'S ZONE 91,G)

VIEW Y (101)

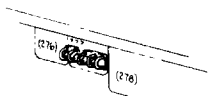

DETAIL W (10) REF)  
THIS DETAIL TYPICAL FOR ALL  
R.H.E.B. VIEWS SEE ZONES  
99 (107) (139)

STRUCTURE-LOWER EQUIPMENT BAY  
Xc-19.125 TO Xc-42.665, ASSY OF  
V36-334001 (REF)

CONTAINER (104) 6 H  
TOWACF V36-11540  
(10) (10) (13) REF)  
SEE DRAWING V36-11540  
ZONE 92, H

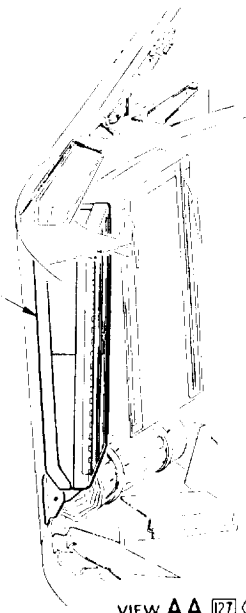

VIEW AA (127) (17) (18) (19)  
SH 6

WIREWAY INSTL-AFT BULKHEAD-  
CENTRAL CREW COMPARTMENT,  
V56-441800 (REF)

116

115

114

3 (4) 3 113

5	A
---	---

112



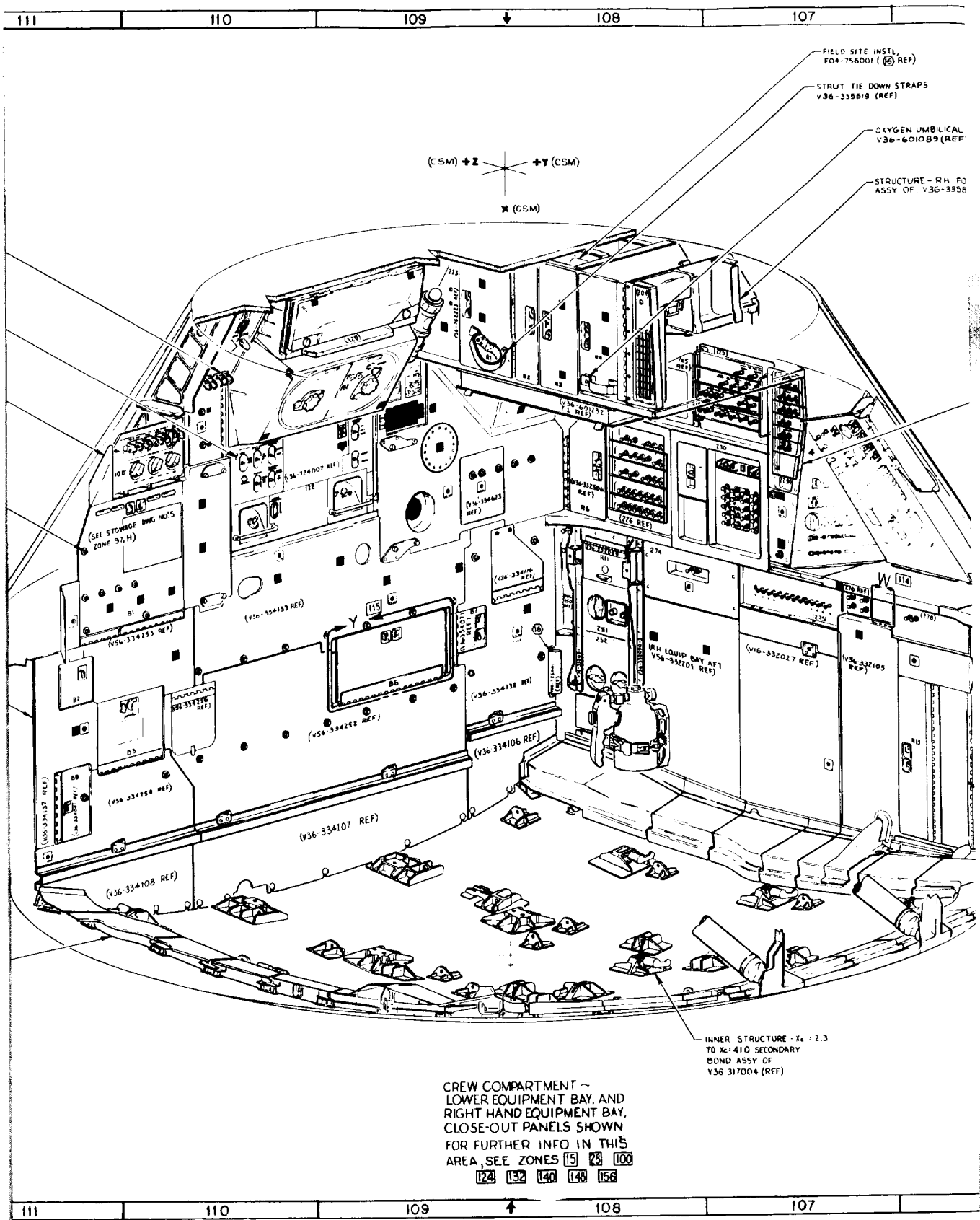

FOLDOUT FRAME 3





STRAP INSTL.

FORWARD EQUIPMENT BAY,  
D1 (REF)

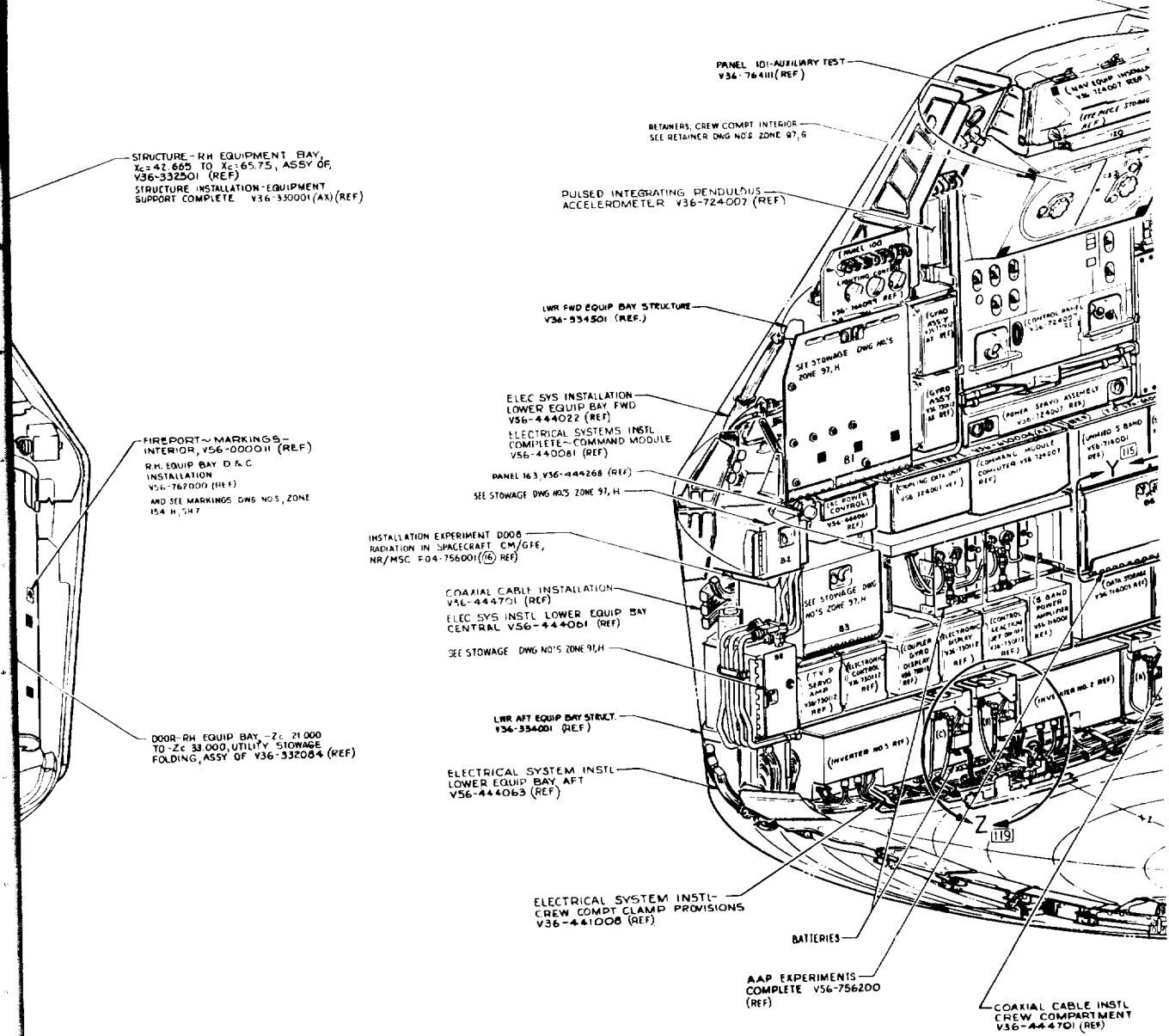

STRUCTURE - RH EQUIPMENT BAY,  
Xc=42.665 TO Xc=65.75, ASSY OF  
V36-332501 (REF)  
STRUCTURE INSTALLATION-EQUIPMENT  
SUPPORT COMPLETE V36-330001(A)(X)(REF)

FIREPORT-MARKINGS-  
INTERIOR, V56-000011 (REF)  
RH EQUIP BAY D & C  
INSTALLATION  
V56-767009 (114 F)  
AND SEE MARKINGS DWG NOS, ZONE  
154 H, 547

DOOR-RH EQUIP BAY-Zc 21.000  
TO-Zc 33.000, UTILITY STOWAGE  
FOLDING, ASSY OF V36-332084 (REF)

GUIDANCE & NAV  
SIGNAL CONDITIONER  
(REF)

PANEL 101-AUXILIARY TEST  
V36-764111 (REF)

RETAINERS, CREW COMPT INTERIOR  
SEE RETAINER DWG NOS ZONE 97, G

PULSED INTEGRATING PENDULOUS  
ACCELEROMETER V36-724007 (REF)

LWR FWD EQUIP BAY STRUCTURE  
V36-334501 (REF)

ELEC SYS INSTALLATION  
LOWER EQUIP BAY FWD  
V56-444022 (REF)  
ELECTRICAL SYSTEMS INSTL  
COMPLETE-COMMAND MODULE  
V56-4440081 (REF)

PANEL 163, V36-444268 (REF)  
SEE STOWAGE DWG NOS ZONE 97, H

INSTALLATION EXPERIMENT DOOR  
RADIATION IN SPACECRAFT CM/GFE,  
NR/MSC F04-756001(16) (REF)

COAXIAL CABLE INSTALLATION  
V36-444701 (REF)  
ELEC SYS INSTL LOWER EQUIP BAY  
CENTRAL V56-4440081 (REF)  
SEE STOWAGE DWG NOS ZONE 97, H

LWR AFT EQUIP BAY STRUCT.  
V36-334001 (REF)

ELECTRICAL SYSTEM INSTL  
LOWER EQUIP BAY AFT  
V56-444063 (REF)

ELECTRICAL SYSTEM INSTL-  
CREW COMPT CLAMP PROVISIONS  
V36-441008 (REF)

BATTERIES

AAP EXPERIMENTS  
COMPLETE V56-756200  
(REF)

COAXIAL CABLE INSTL  
CREW COMPARTMENT  
V36-444701 (REF)



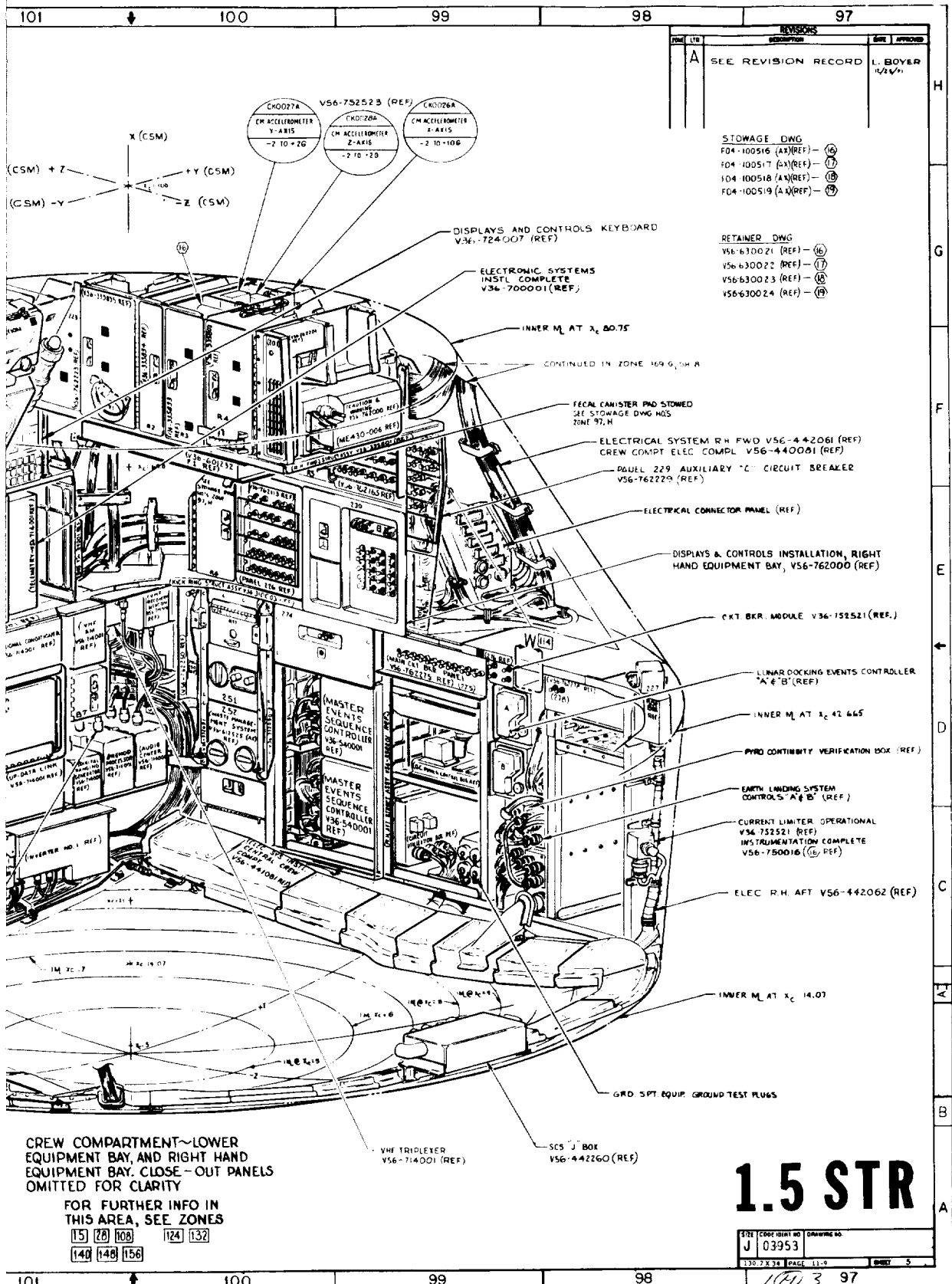

CREW COMPARTMENT~LOWER EQUIPMENT BAY, AND RIGHT HAND EQUIPMENT BAY. CLOSE-OUT PANELS OMITTED FOR CLARITY

FOR FURTHER INFO IN THIS AREA, SEE ZONES  
 115 120 108 124 132  
 140 148 156

**1.5 STR**

SIZE	CODE	DRAWING NO.
J	03953	
130-7 X 34	PAGE	11-9
	SHEET	5

FOLDOUT FRAME 5

1. The first part of the document is a list of names and titles, including "The Hon. Mr. Justice" and "The Hon. Mr. Justice".

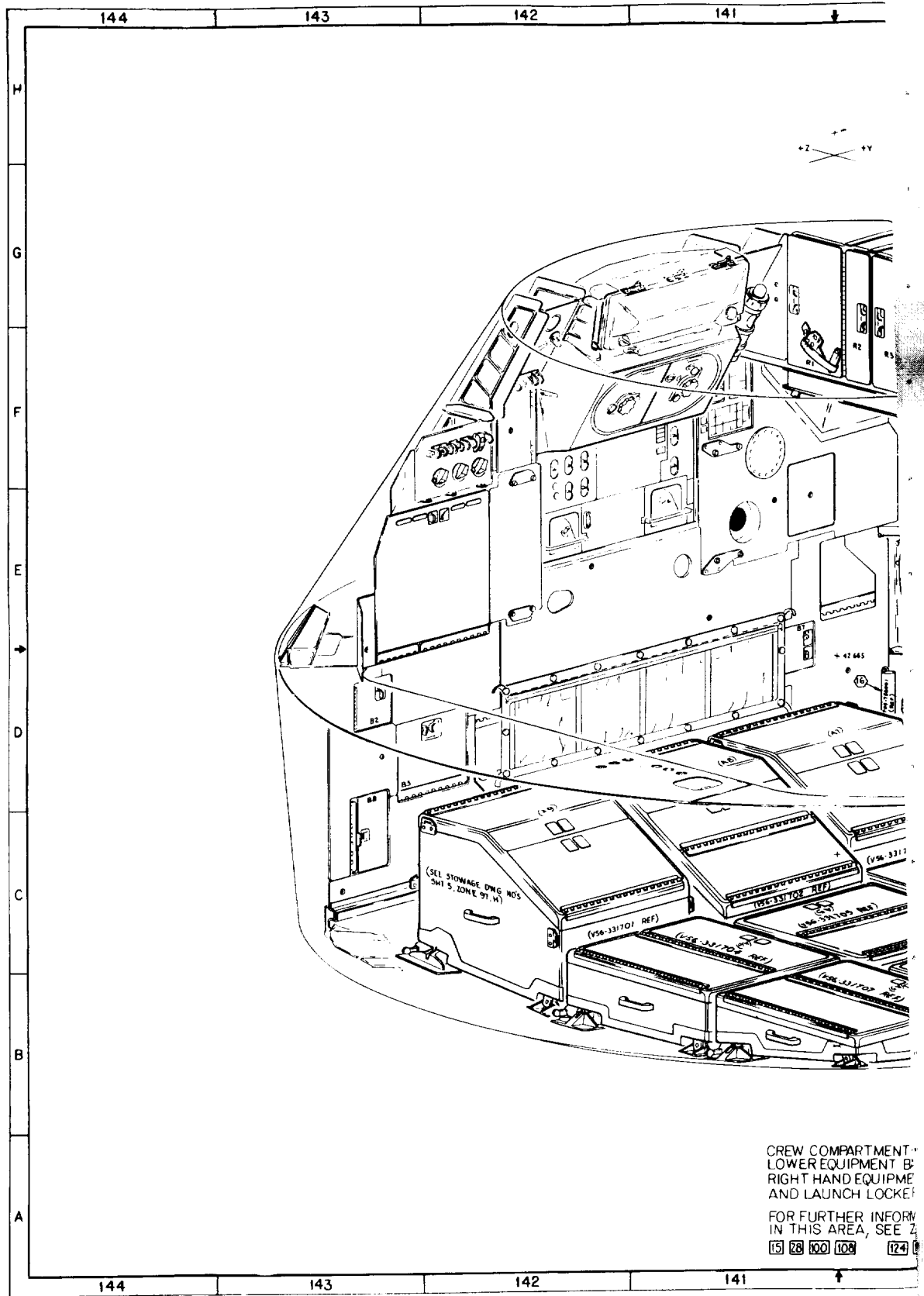

FOLDOUT FRAME 1



140

139

138

137

136

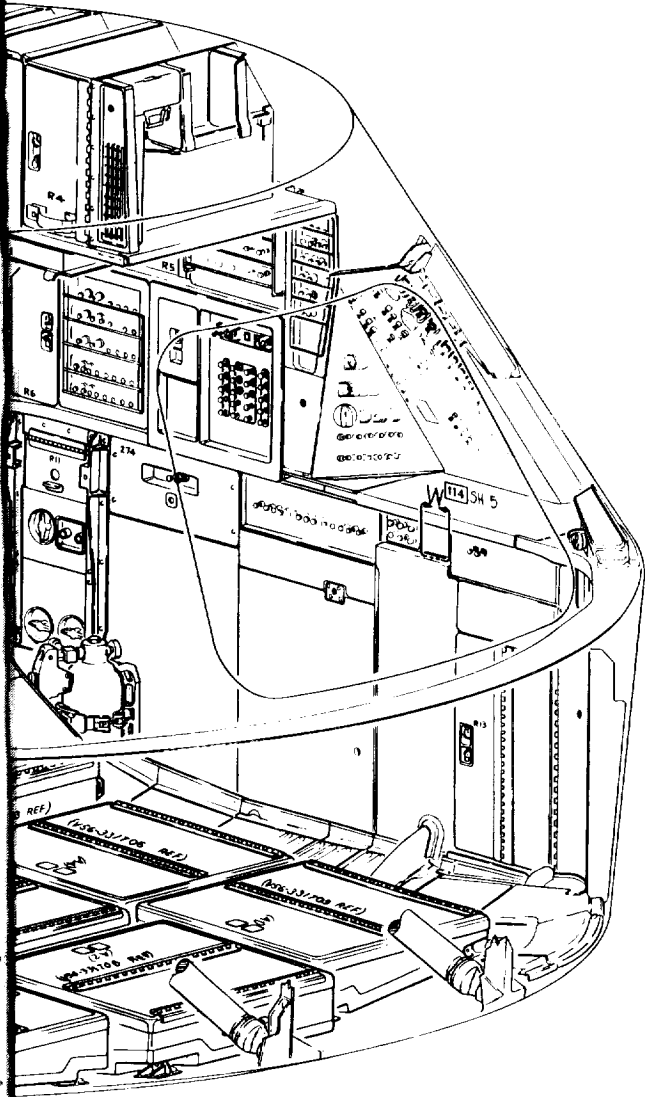

DESIGN LAYOUT INTERIOR  
 CONFIGURATION AND  
 MARKINGS, SEE MARKINGS  
 DWG. NO'S ZONE 154,H, SH 7

Y, AND  
 NT BAY  
 S SHOWN

ATION  
 ONES

32

140

139

138

137

SH	REV
6	A

323

136

FOLDOUT, FRAME 2

2020



135

134

133

132

131

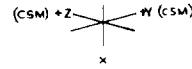

TRANSLATION CONTROL  
V36-730102 (AX) (REF)

ELECTRONIC SYSTEM INSTL COMPLETE  
V56-700001 (REF)  
EQUIP INSTL STABILIZATION &  
CONTROL SYS  
V36-730102 (AX) (REF)

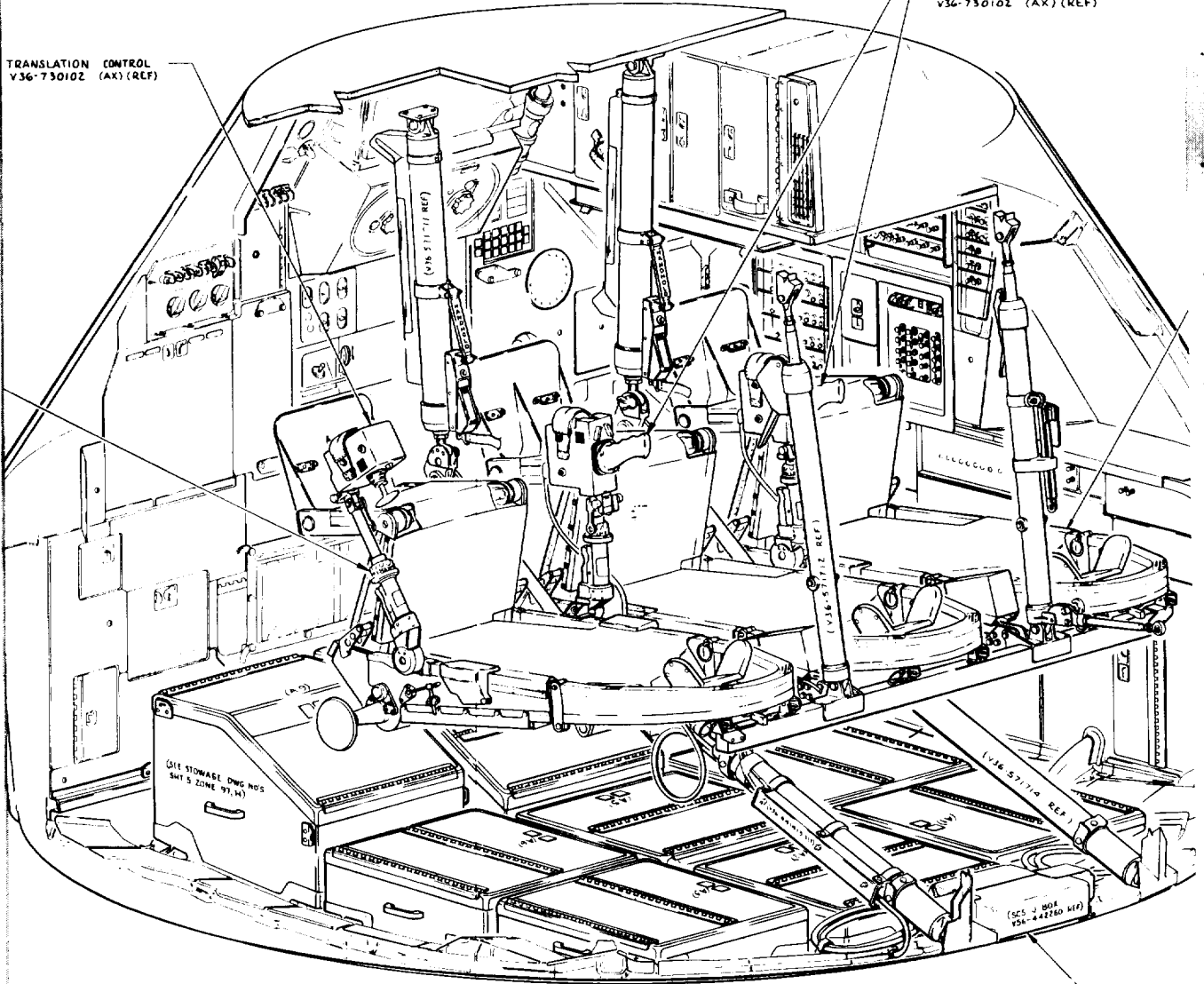

CREW COMPARTMENT~  
VIEW LOOKING DOWN AND INBOARD  
FOLDABLE CREW COUCHES  
FOR FURTHER INFO IN  
THIS AREA, SEE ZONES  
15 20 100 108  
124 140

ELECTRICAL SYS1  
CENTRAL CREW C  
V56-441081 (REF)

135

134

133

132

131



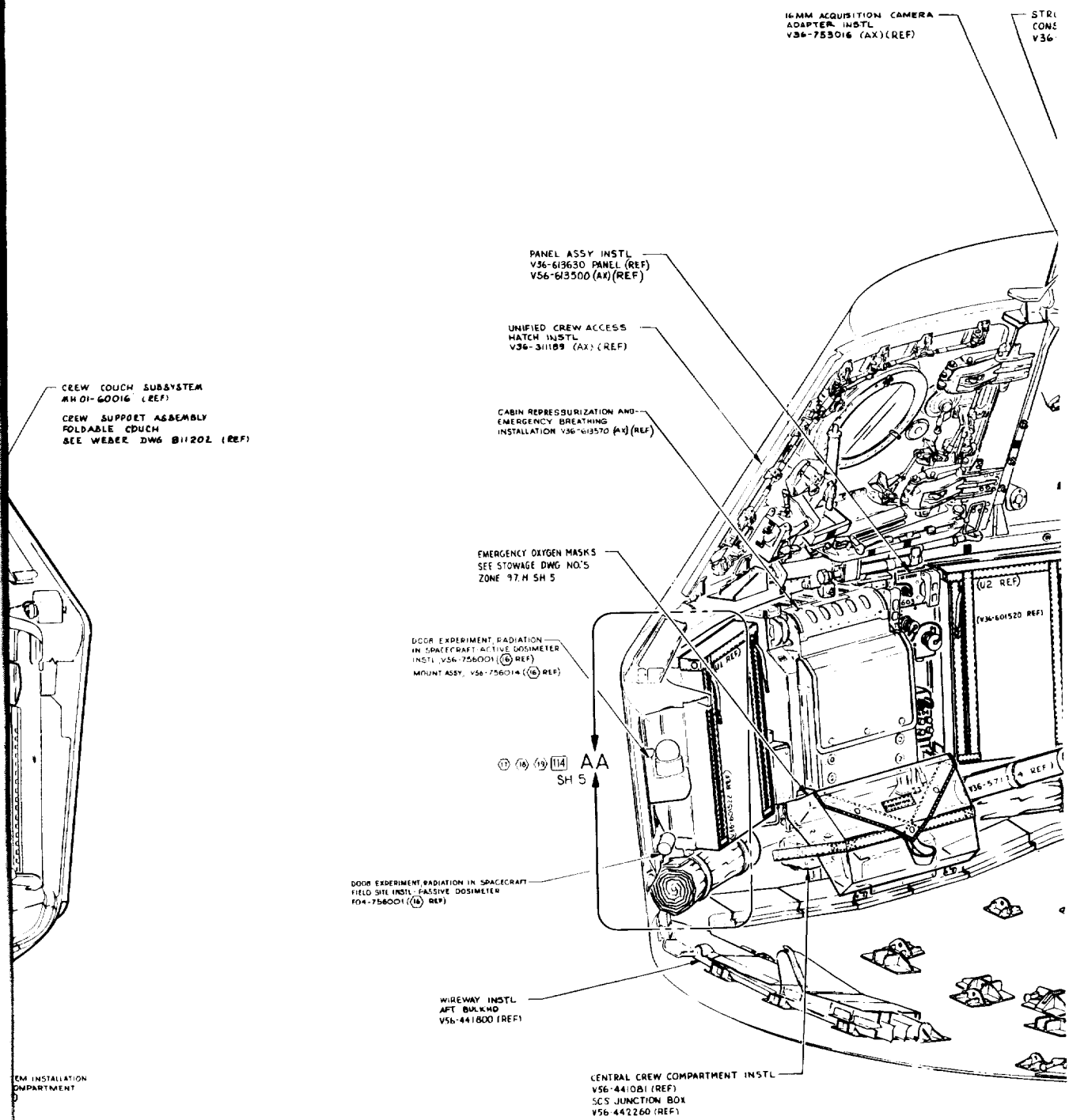



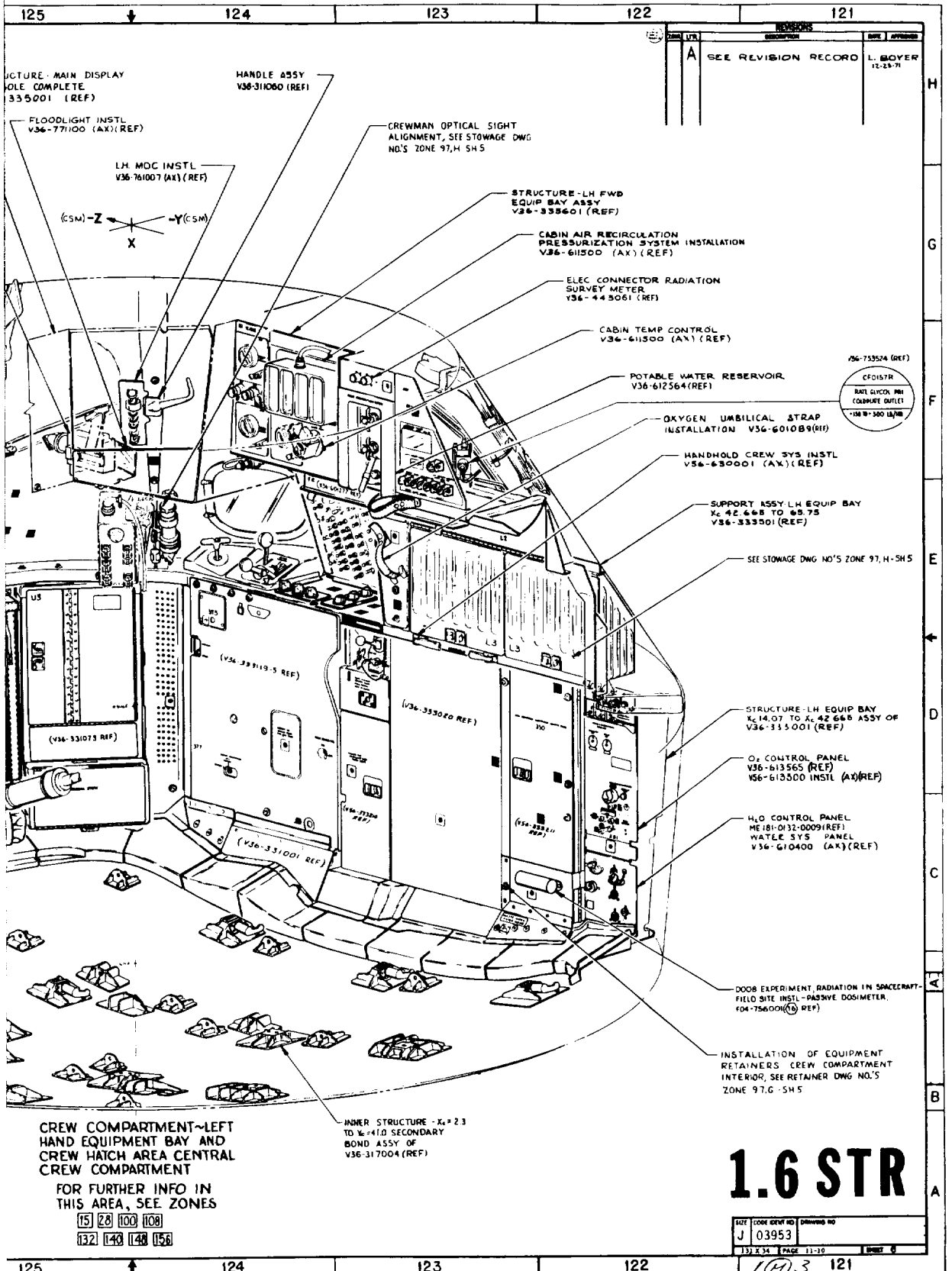



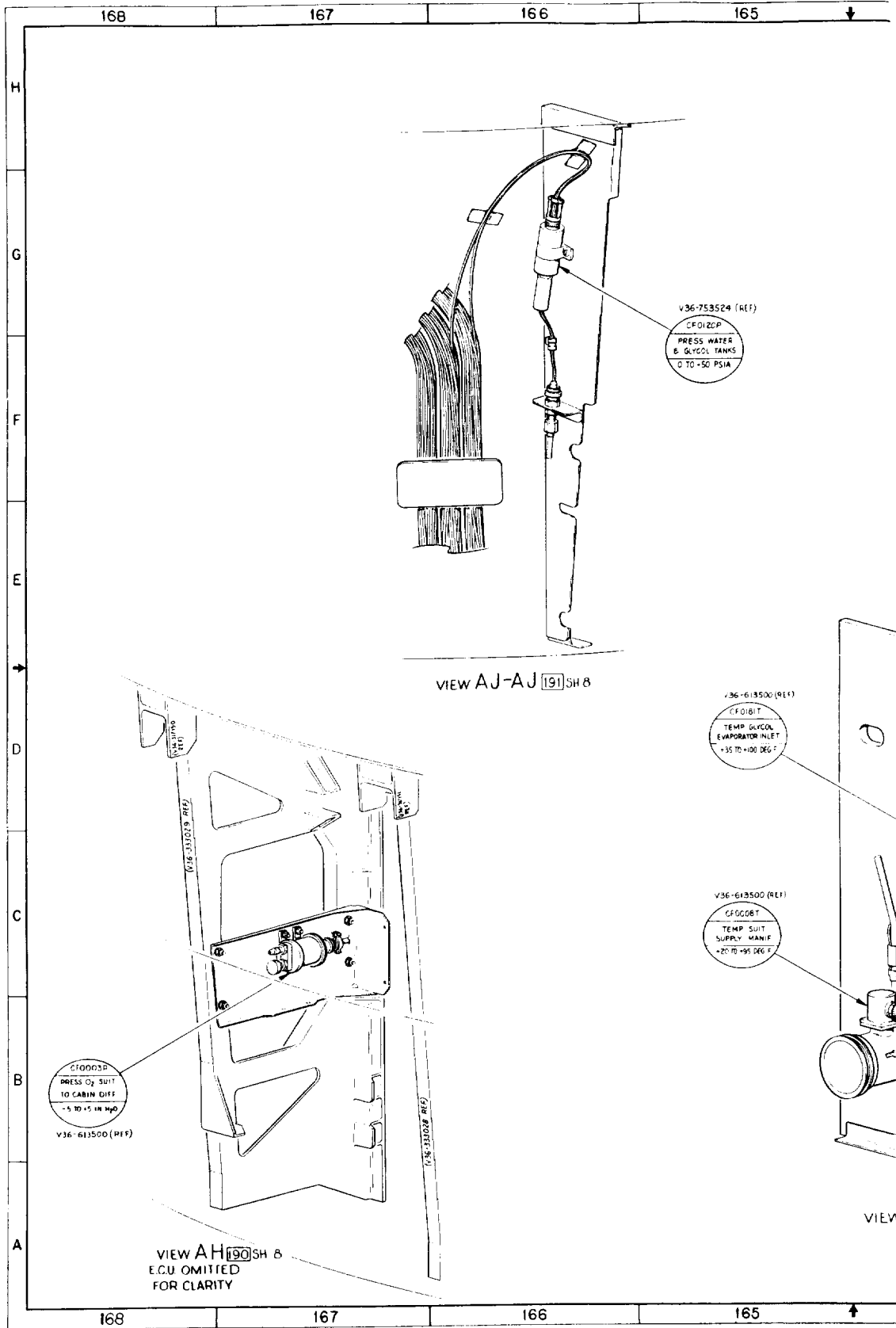

**EOLDOUT FRAME**

4. 1. 1. 1. 1.



164

163

162

161

160

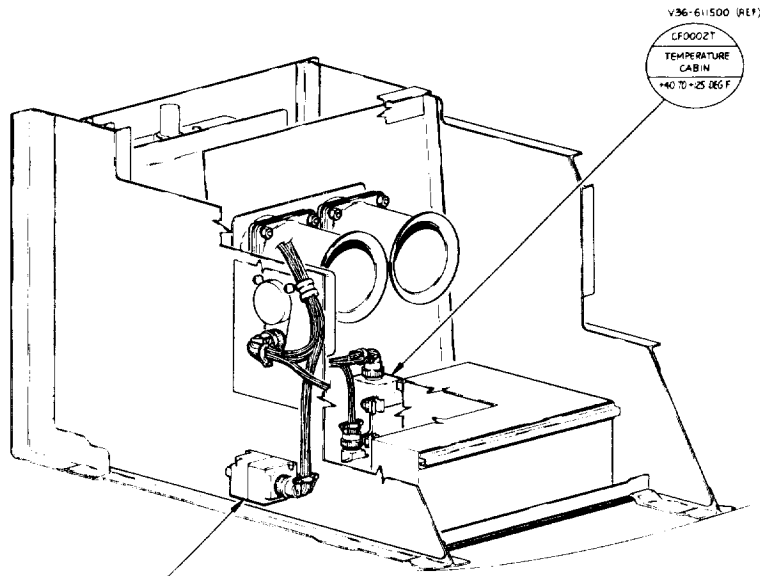

STOWAGE ASSY-FWD  
V36-601232 (REF)

AE

VIEW AF-AF 182 SH 8

- STRUCTURE, MAIN DISPLAY CONSOLE Y36-335001 (REF)
- COMPLETE DISPLAYS AND CONTROLS INSTL Y56-761101 (AX) (R)
- MAIN DISPLAY CONSOLE INSTL V56-761000 (REF)
- DESIGN LAYOUT, INSTRUMENT FACES, MAIN DISPLAY CONSOLE V56-976001 (REF)
- ELECTRICAL SYS INSTL, MAIN DISPLAY CONSOLE V56-445061 (REF)
- ENVIRONMENTAL CONTROL SYS INSTL COMPLETE V36-610001(A4) (REF)

DUCT - SUIT CIRCUIT TO ENVIRONMENTAL CONTROL UNIT SUPPLY  
V36-615814 (REF)

PANEL ASSY NO.16 R.H. LL  
SIDE DISPLAY CONSOLE  
V36-761096 (REF)

UNIFIED CREW AI  
INSTL V36-311099

G-AG 189 SH 8

164

163

162

3 (A) 3 161

160

7 A



159

158

157

156

155

MARKINGS D:  
V56-900116;  
V56-900117;  
V56-900118;  
V56-900119;

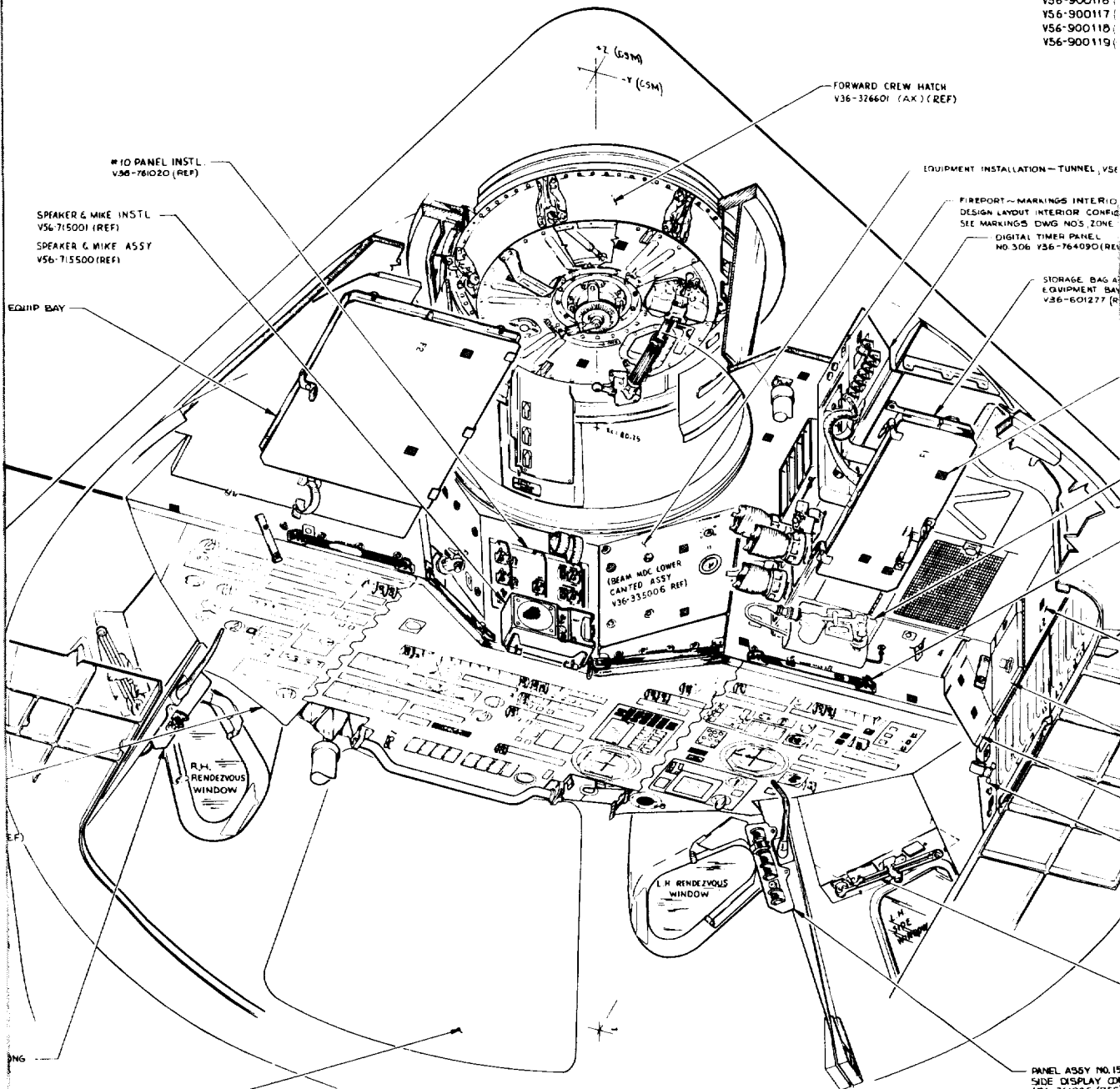

ACCESS HATCH (AX) (REF)

VIEW LOOKING FWD AT  
MAIN DISPLAY CONSOLE,  
FORWARD BULKHEAD, FWD HATCH,  
UPPER SIDE WALL, MAIN CREW  
HATCH, L.H. WINDOWS, L.H.  
FWD AND INTERMEDIATE EQUIP BAYS

FOR FURTHER INFO IN THIS AREA  
SEE ZONES 15 28 100 108  
124 132 140 148

159

158

157

156

155

FOLDOUT FRAME 3

10/10/10

VG  
 AX) (REF) ⑤  
 AX) (REF) ⑥  
 AX) (REF) ⑦  
 AX) (REF) ⑧

-616500 (REF)  
 R V56-000011 (REF)  
 URATION AND MARKINGS  
 54.H  
 )  
 SSY FWD  
 (EF)

RETAINERS-EQUIPMENT (CREW COMPARTMENT  
 INTERIOR, INSTALLATION OF SEE RETAINER  
 DWG NO'S ZONE 97, G, SH 5

WATER DISPENSER ASSY  
 V16-601521 (REF)

HANDHOLD CREW SYS INSTL  
 V56-630001 (AX) (REF)

DOOR-L.H. INTERMEDIATE BAY  
 STOWAGE COMPARTMENT  
 V36-333513 (REF)  
 L.H. INTERMEDIATE STRUCTURE  
 V36-333601 (REF)

COVER-ELECTRICAL CONNECTOR  
 SUPPORT L.H. EQUIP BAY  
 V36-443236 (REF)

PANEL CLOSEOUT  
 V36-333614 (REF)

OXYGEN UMBILICAL STRAP  
 INSTALLATION V16-601089 (REF)

AE ①⑦ SH 8

MIRROR ASSY-INTERNAL  
 VIEWING V16-601471 (REF)

L.H. LONG  
 TUBE

R.H. MAIN CONNECTOR, SUIT NO. 1  
 V36-613800 (AX) (REF)  
 SEE STOWAGE DWG NO'S ZONE 97, H, SH 5  
 (3) ELEC CONNECTORS CREWMAN  
 SUIT UMBILICALS  
 L.H. MAIN CONNECTOR, SUIT NO. 3  
 V36-613800 (AX) (REF)  
 SEE STOWAGE DWG NO'S ZONE 97, H, SH 5  
 ELEC SYS INSTL L.H. FWD COMPT  
 V36-443061 (REF)  
 ELEC SYS-CREW COMPT COMPART  
 V36-440081 (REF)  
 SUPPORT ASSY-LH EQUIP BAY  
 Xc 42 665 TO Xc 65 75 ~  
 V36-333501 (REF)

CAR  
 V36

CENTER MAIN CONN  
 V36-613800 (AX)  
 SEE STOWAGE DWG

STRUC  
 EQUIP

ELEC CONNECTOR SUPPORT  
 V36-333501 (REF)

RETAINERS-EQUIPMENT, COLDW  
 COMPARTMENT INTERIOR,  
 INSTALLATION OF  
 SEE RETAINER DWG NO'S ZONE  
 97, G, SH 5

OXYGEN OUTLET  
 V36-613800 (AX) (REF)

DUAL CHECK VALVE  
 V56-613500 (AX) (REF)

AC ①⑧ SH 8

SURGE TANK PRESS  
 RELIEF VALVE  
 V56-613500 (AX) (REF)  
 V56-613600 (AX) (REF)

AD ①⑧ SH 8

STRUCTURE ASSY-LH EQUIP BAY  
 Xc 14 07 TO Xc 42 665 ~  
 V36-333000 (REF)

ELEC SYS INSTL LH AFT  
 EQUIP BAY V36-443042  
 (REF)

GLYCOL PUMP PACKAGE  
 V36-610004 (AX) (REF)

WATER GLYCOL CONTROL

ENVIRONMENTAL CONTROL UNIT  
 ME 501-0737 (REF)  
 ENVIRONMENTAL CONTROL SYS INSTL  
 L.H. EQUIP BAY  
 V36-613600 (AX) (REF)  
 ENVIRONMENTAL CONTROL SYS INSTL COMP  
 V36-610001 (REF)

SH	REV
7	A

FOLDOUT FRAME 4

10/10/10

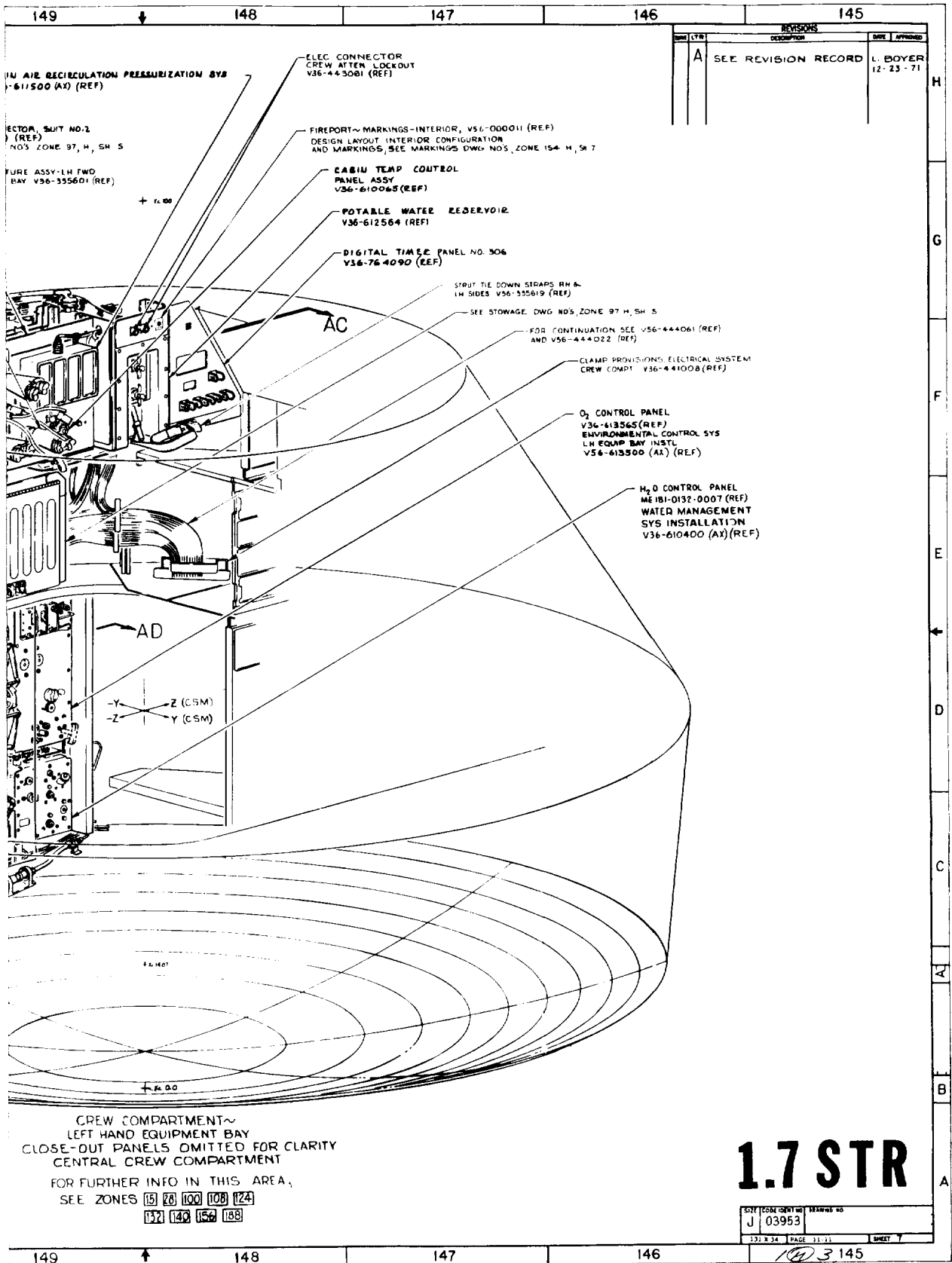

FOLDOUT FRAME 5





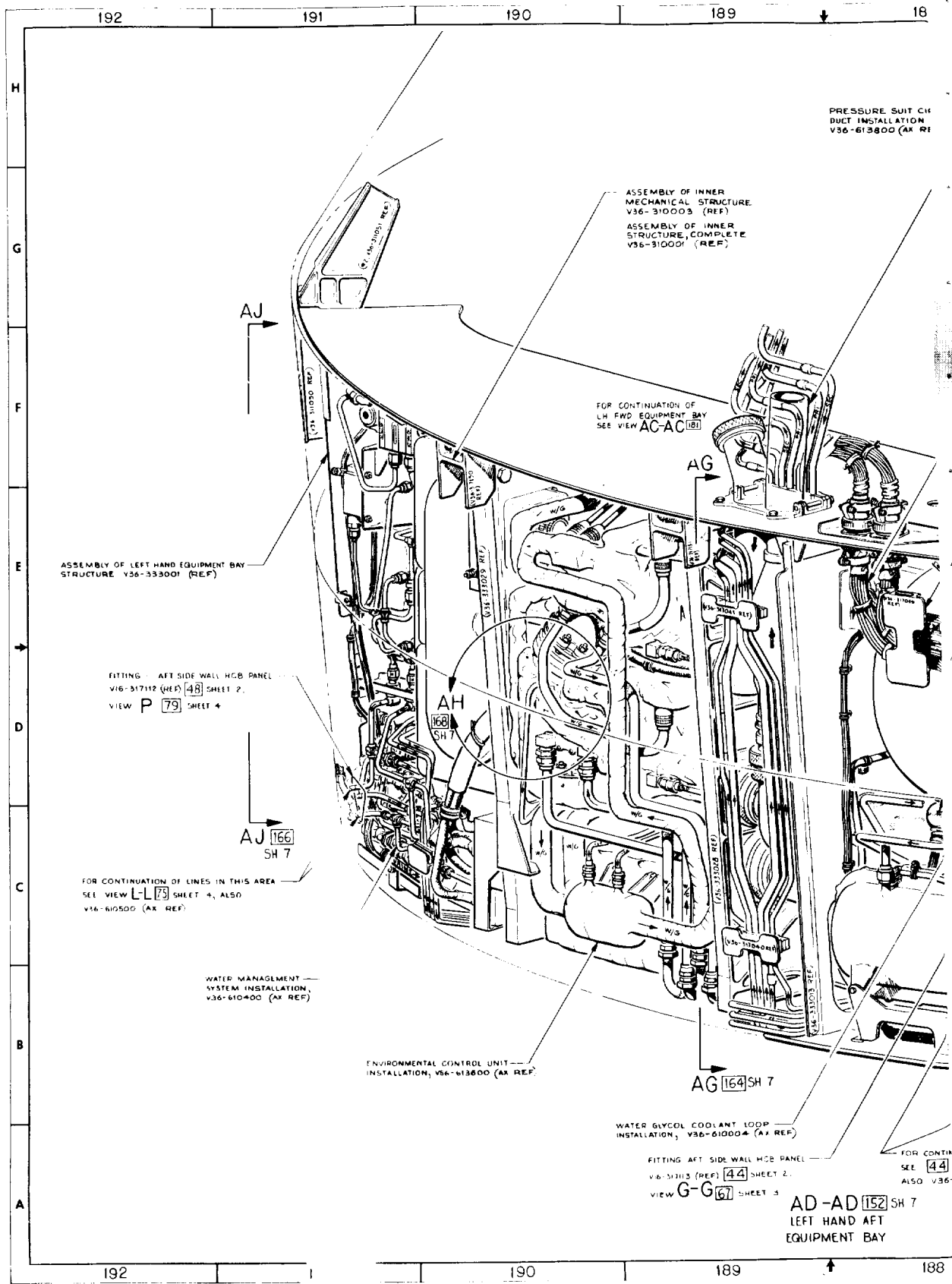

PRESSURE SUIT CH  
DUCT INSTALLATION  
V36-613800 (AX REF)

ASSEMBLY OF INNER  
MECHANICAL STRUCTURE  
V36-310003 (REF)  
ASSEMBLY OF INNER  
STRUCTURE, COMPLETE  
V36-310001 (REF)

FOR CONTINUATION OF  
LH FWD EQUIPMENT BAY  
SEE VIEW AC-AC 181

ASSEMBLY OF LEFT HAND EQUIPMENT BAY  
STRUCTURE V36-333001 (REF)

FITTING - AFT SIDE WALL HCB PANEL  
V16-317112 (REF) 48 SHEET 2,  
VIEW P 79 SHEET 4

FOR CONTINUATION OF LINES IN THIS AREA  
SEE VIEW L-L 75 SHEET 4, ALSO  
V16-610500 (AX REF)

WATER MANAGEMENT  
SYSTEM INSTALLATION,  
V36-610400 (AX REF)

ENVIRONMENTAL CONTROL UNIT -  
INSTALLATION, V36-613800 (AX REF)

WATER GLYCOL COOLANT LOOP  
INSTALLATION, V36-610004 (AX REF)

FITTING AFT SIDE WALL HCB PANEL  
V16-313113 (REF) 44 SHEET 2,  
VIEW G-G 67 SHEET 3

FOR CONTIN  
SEE 44  
ALSO V36

AD-AD 152 SH 7  
LEFT HAND AFT  
EQUIPMENT BAY

**FOLDOUT FRAME**

1. 2. 3. 4. 5. 6. 7. 8. 9. 10. 11. 12. 13. 14. 15. 16. 17. 18. 19. 20. 21. 22. 23. 24. 25. 26. 27. 28. 29. 30. 31. 32. 33. 34. 35. 36. 37. 38. 39. 40. 41. 42. 43. 44. 45. 46. 47. 48. 49. 50. 51. 52. 53. 54. 55. 56. 57. 58. 59. 60. 61. 62. 63. 64. 65. 66. 67. 68. 69. 70. 71. 72. 73. 74. 75. 76. 77. 78. 79. 80. 81. 82. 83. 84. 85. 86. 87. 88. 89. 90. 91. 92. 93. 94. 95. 96. 97. 98. 99. 100.

187

186

185

184

183

ELECTRICAL SYSTEM INSTALLATION  
LEFT HAND AFT EQUIPMENT BAY  
V36-443042 (REF)

ASSEMBLY OF SECONDARY BOND  
INNER STRUCTURE  
V36-317004 (REF)

ENVIRONMENTAL CONTROL SYSTEM  
EQUIPMENT INSTALLATION, L.H. EQUIP  
BAY V36-613500 (AK REF)  
ENVIRONMENTAL CONTROL SYSTEM  
INSTALLATION, COMPLETE  
V36-610001 (REF)

✱ X = 42.665

(V36-613500 REF)  
CFGD.1\*\*  
TEMP OLVDR EXHP  
OUTLET STEAM  
+20 TO +95 DEG F

+Z  
+Y  
(CSM) -Y  
-Z (CSM)

(V36-753521 REF)  
CF0206P  
PRESSURE  
SURGE TANK  
+50 TO +150 PSIA

✱ X = 29.125

WATER  
INSTL

LH EQUIPMENT BAY SUPPORT  
ASSY. V36-533501 (REF)

FOR CONTINUATION SEE  
V36-443061 AND  
V36-444022

+ X = 14.07

+ X = 15.0

+ X = 0

ELEC SYS INSTL LH FWD  
EQUIP BAY V36-443061 (REF)  
CREW COMPARTMENT ELEC  
SYS INSTL COMPLETE  
V36-440081 (REF)

BONDED ASSY OF INNER  
STRUCTURE Xc = 41.0 TO Xc  
V36-311004 (REF)

LOCATION OF LINES IN AFT COMPARTMENT  
SHEET 2, VIEW J-J [67] SHEET 3,  
V36105000 (AK REF)

CENTRAL CREW COMPARTMENT  
ELECTRICAL SYSTEM INSTALLATION,  
V36-441081 (REF)  
ELECTRICAL SYSTEM INSTALLATION,  
COMPLETE, V36-440001 (REF)

CF00201  
V36-610003  
(REF)  
TEMP SPACE  
RADIATOR OUTLET  
+50 TO +100 DEG F

WASTE MANAGEMENT SYSTEM  
LINE AND EQUIPMENT INSTALLATION,  
V36-612525 (AK REF)  
CONTINUED DN  
V36-610500 (AK REF)

SH REF

187

186

3/11/3 185

184

183



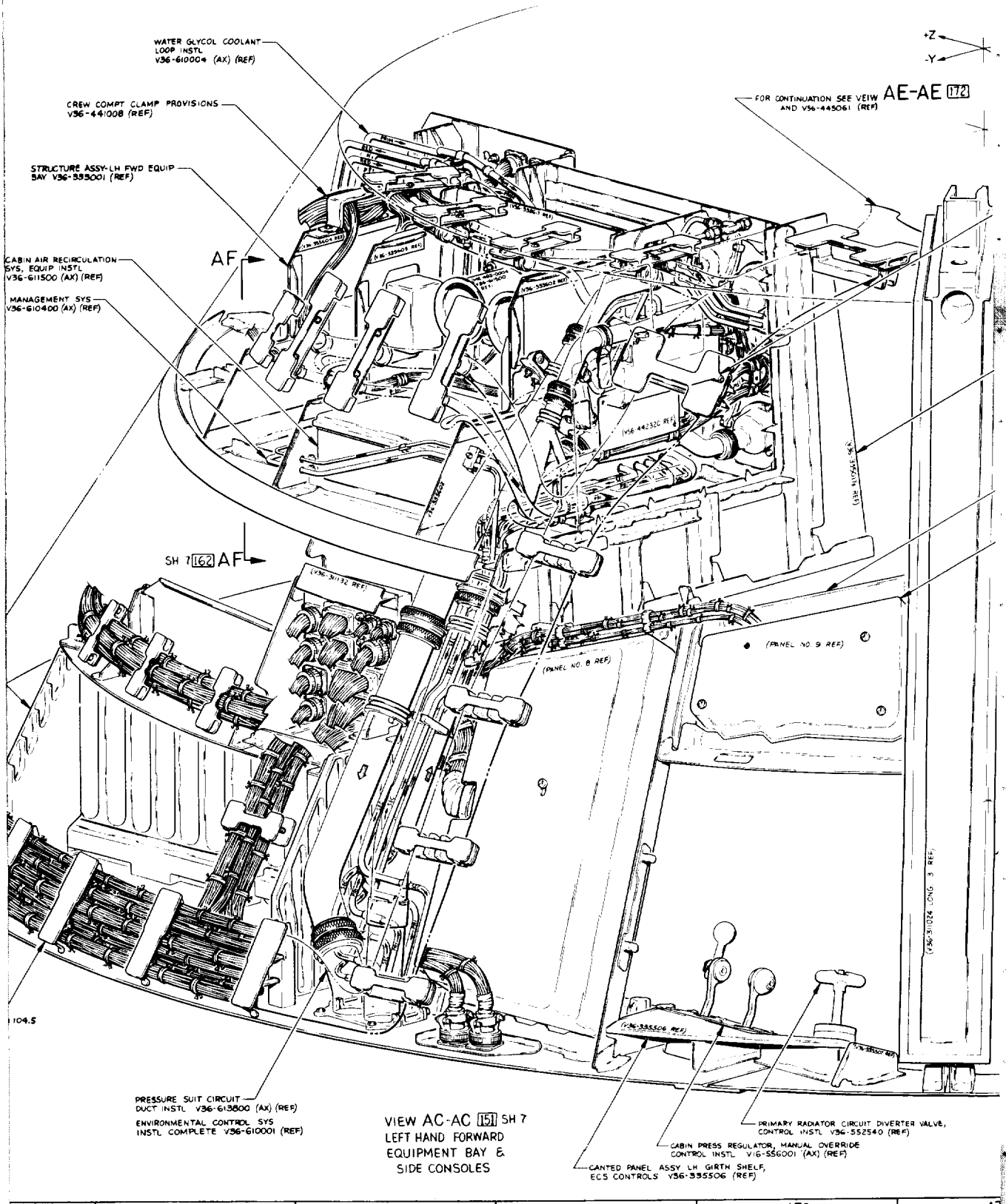

1000

+Y (CSM)  
-Z (CSM)

X: 82.13  
CF0005P  
PRESS CO<sub>2</sub>  
PARTIAL  
0 TO +30 mm Hg  
V36-613800 (REF)

CONTINUED IN VIEW AC-AC (B) AND V36-443061 (REF)

CLAMP PROVISIONS, CREW COMPARTMENT  
ELECTRICAL SYS INSTL V36-44100B (REF)

MAIN DISPLAY  
STRUC COMP  
V36-3350C  
+Z  
+Y

M. D. C. ELECTRICAL  
V36-445061 (REF)

MAIN DISPLAY CONSOLE  
STRUC COMPLETE  
V36-335001 (REF)

SIDE CONSOLE STRUC COMPLETE  
V36-335501 (REF)

DISPLAY PANEL INSTL  
PANELS 7, 8, 9, & 15  
V36-761007 (REF)

(V36-761035 PANEL #15 REF)

X: 42.665  
INNER STRUC HCOMB PANEL  
ASSY V36-31002 (REF)

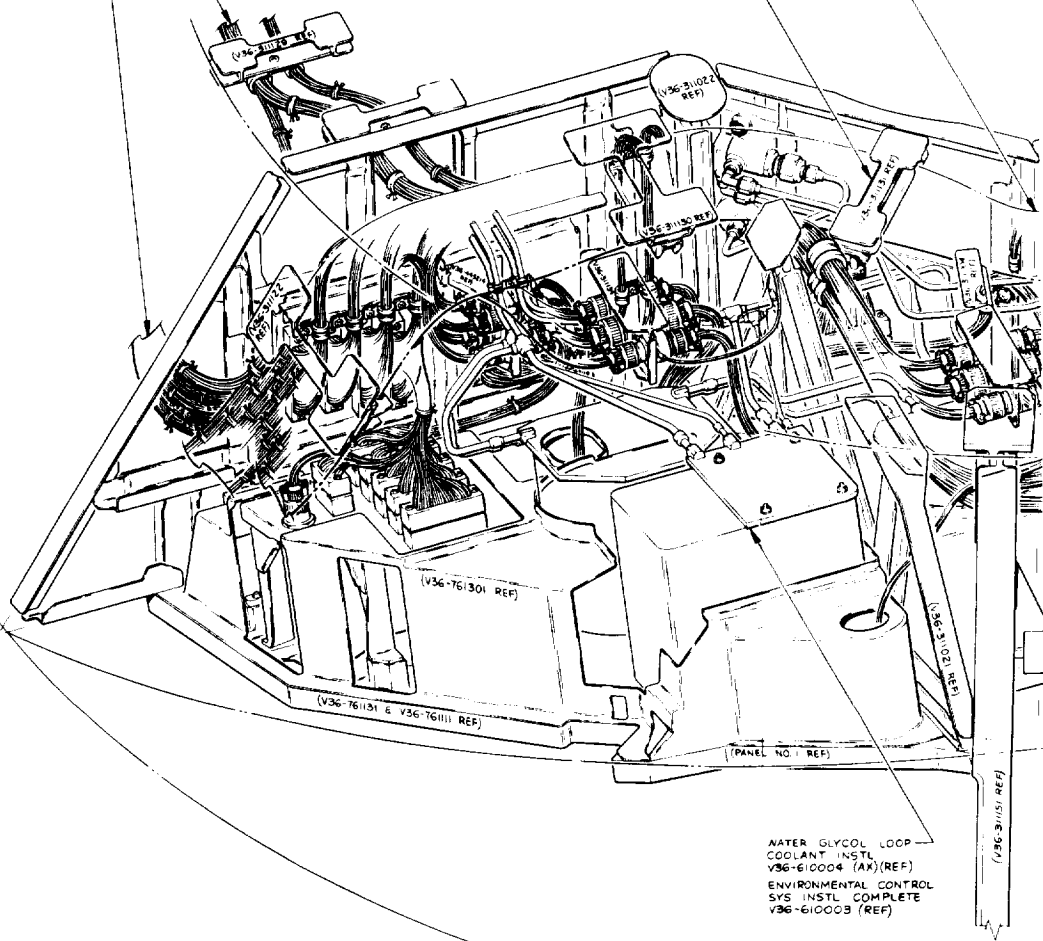

WATER GLYCOL LOOP  
COOLANT INSTL  
V36-610004 (AK) (REF)  
ENVIRONMENTAL CONTROL  
SYS INSTL COMPLETE  
V36-610003 (REF)

FWD S

1





| REVISIONS |                     |                     |
|-----------|---------------------|---------------------|
| ZONE/LET  | DESCRIPTION         | DATE   APPROVED     |
| A         | SEE REVISION RECORD | L. BOYER<br>2-23-71 |

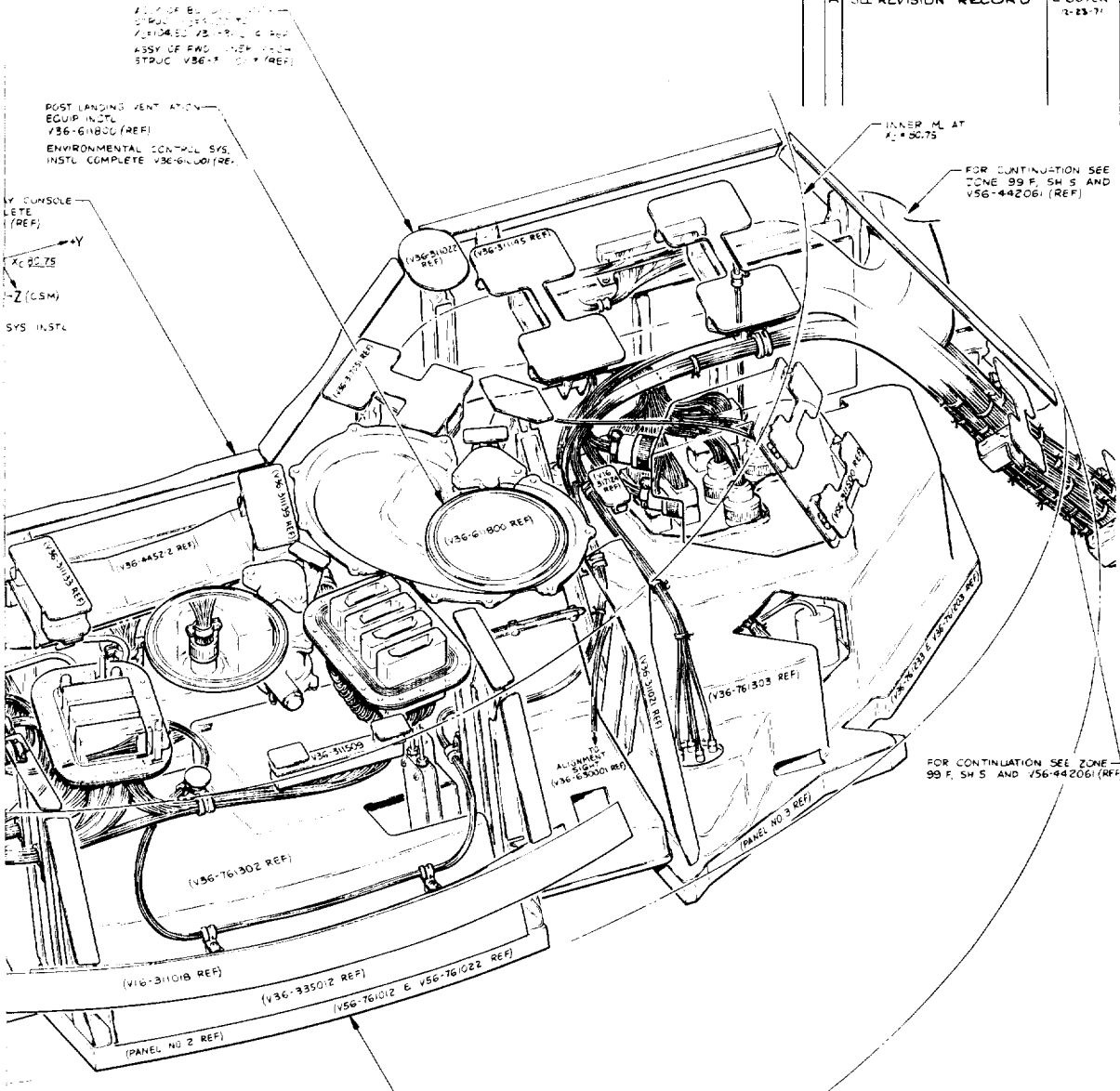

AE-AE 156 SH 7  
 SIDE OF MAIN DISPLAY CONSOLE

**1.8 STR**

|          |               |            |
|----------|---------------|------------|
| SIZE     | CODE IDENT NO |            |
| J        | 03953         | V54-000116 |
| 131 X 34 | PAGE 11-12    | SHEET 6    |

FOLDOUT FRAME 5

1000

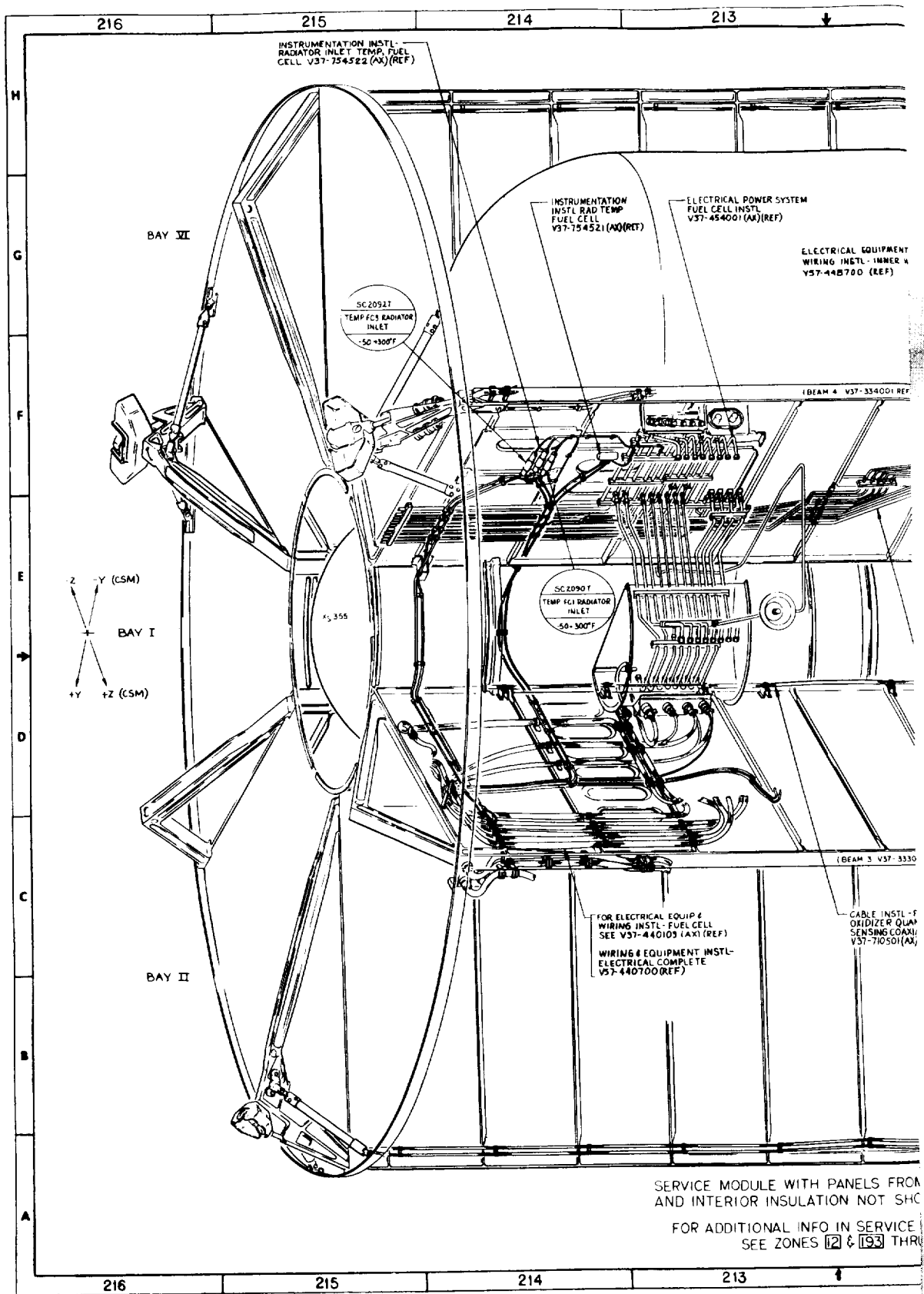

**EOLDOUT FRAME /**

1. 2. 3. 4. 5. 6. 7. 8. 9. 10. 11. 12. 13. 14. 15. 16. 17. 18. 19. 20. 21. 22. 23. 24. 25. 26. 27. 28. 29. 30. 31. 32. 33. 34. 35. 36. 37. 38. 39. 40. 41. 42. 43. 44. 45. 46. 47. 48. 49. 50. 51. 52. 53. 54. 55. 56. 57. 58. 59. 60. 61. 62. 63. 64. 65. 66. 67. 68. 69. 70. 71. 72. 73. 74. 75. 76. 77. 78. 79. 80. 81. 82. 83. 84. 85. 86. 87. 88. 89. 90. 91. 92. 93. 94. 95. 96. 97. 98. 99. 100.

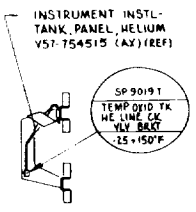
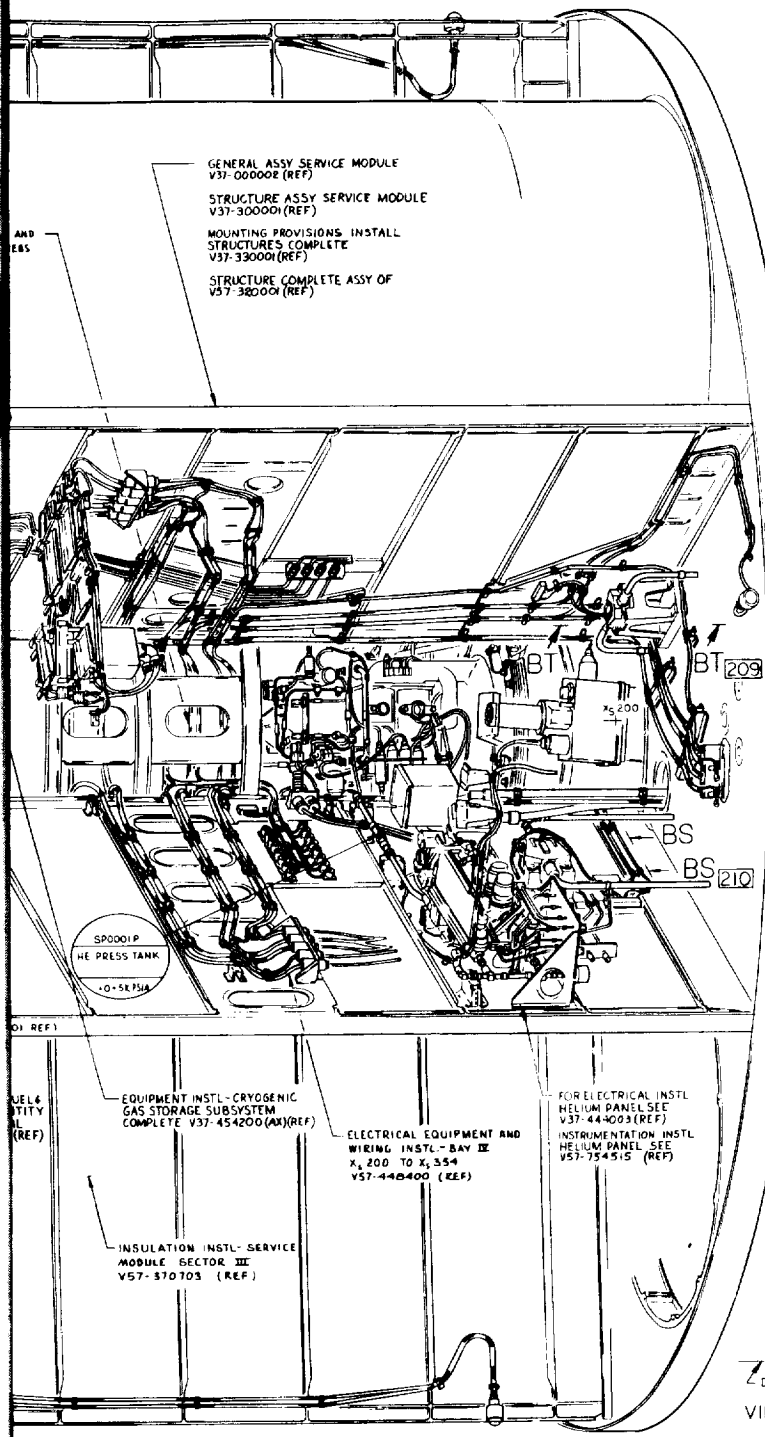

VIEW BS-BS 210

BAY V

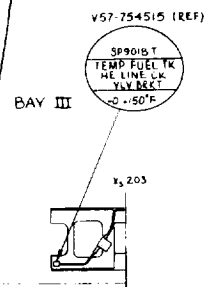
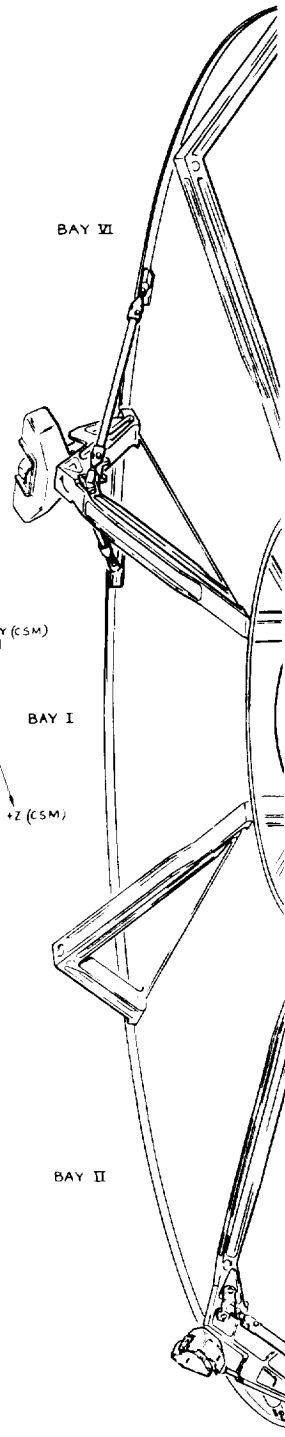
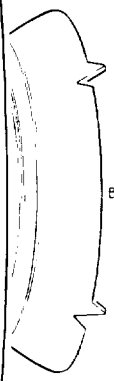

BAY III

DATUM PLANE OF BEAM NO. 4  
VIEW BT-BT 210

CHECK VALVE REMOVED  
FOR CLARITY

BAYS III, IV, V  
OWN FOR CLARITY

MODULE AREA  
304

2023

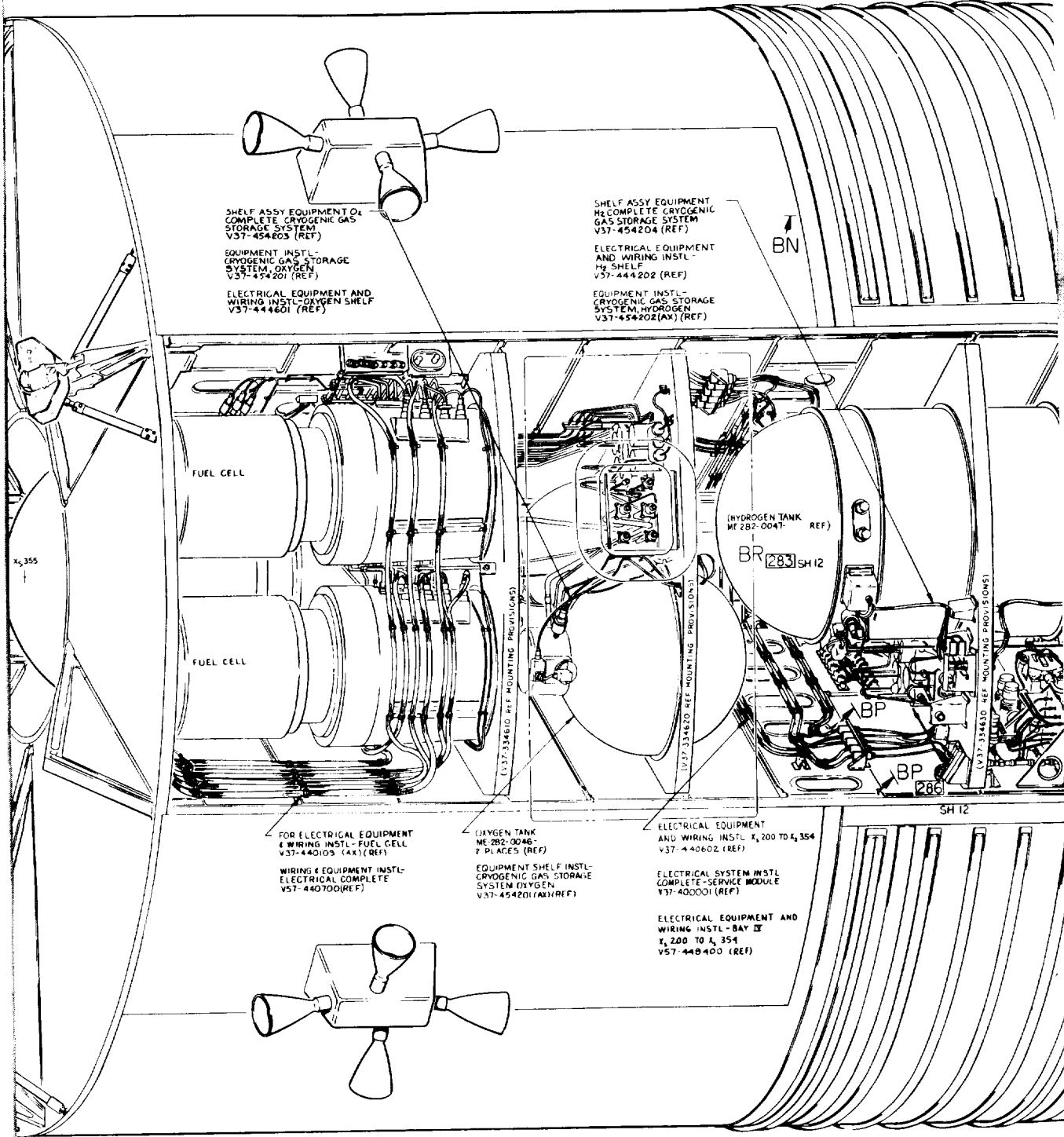

SERVICE MODULE WITH BAY IV PANEL AND INTERIOR INSULATION NOT SHOWN FOR CLARITY  
 FOR ADDITIONAL INFO IN SERVICE MODULE AREA SEE ZONES [2] & [19] THRU [304]

2023



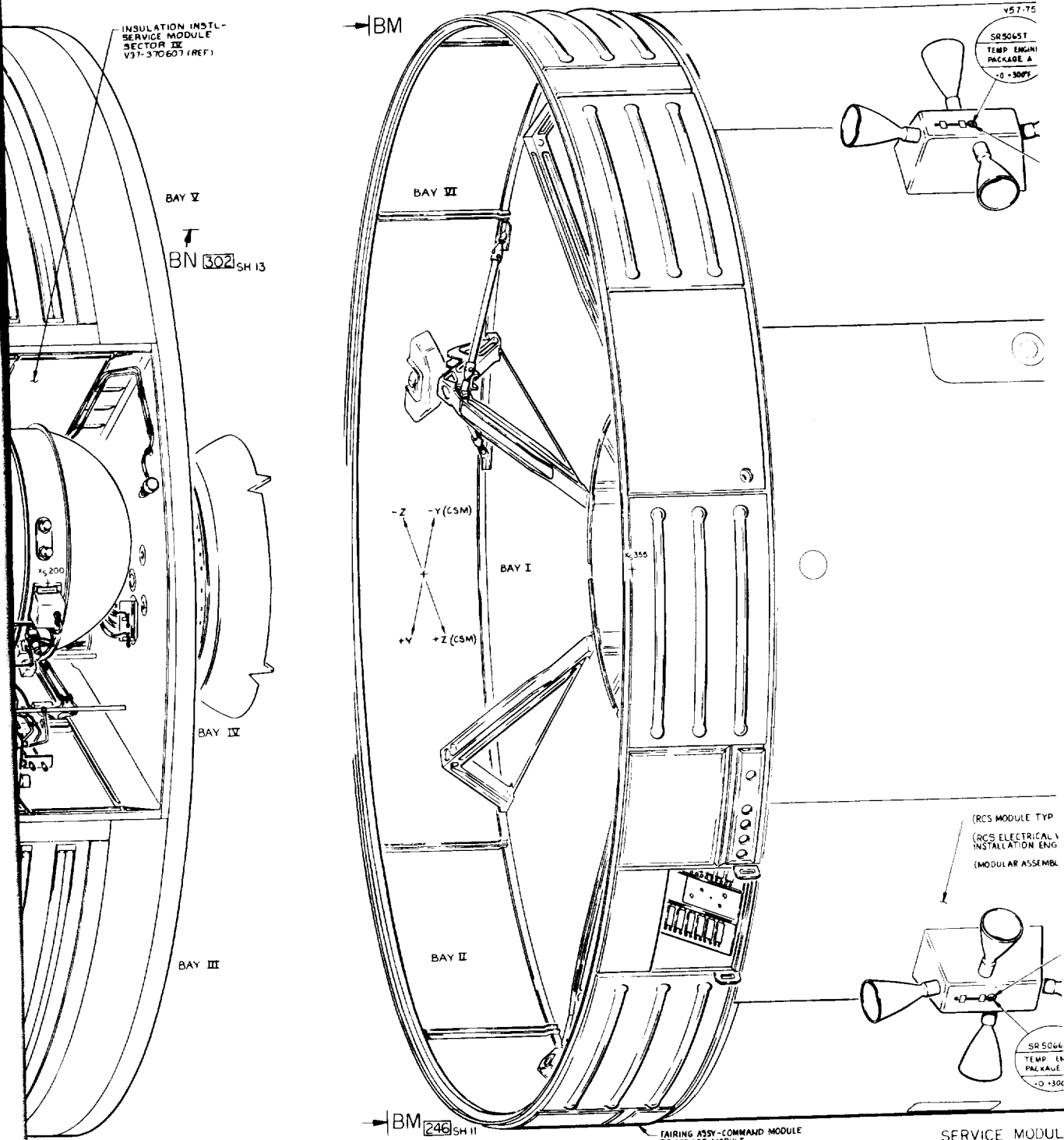

INSULATION INSTL -  
SERVICE MODULE  
SECTOR IX  
V37-370607 (REF)

V57-75

SR50651  
TEMP ENGINI  
PACKAGE A  
-10 +300°

BAY V

BAY VI

BM 302 SH 13

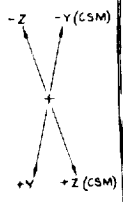

BAY I

BAY IV

BAY III

BAY II

(RCS MODULE TYP  
(RCS ELECTRICAL  
INSTALLATION ENG  
(MODULAR ASSEMBL

SR5066  
TEMP EN  
PAK PACKAGE  
-10 +300°

BM 246 SH II

FAIRING ASSY - COMMAND MODULE  
TO SERVICE MODULE  
V37-310010 (REF)  
FAIRING INSTL - COMMAND MODULE  
TO SERVICE MODULE  
V37-310000 (REF)

SERVICE MODUL  
LOOKING AT  
FOR ADDITIONAL INF  
SEE ZONES

REV 9 A



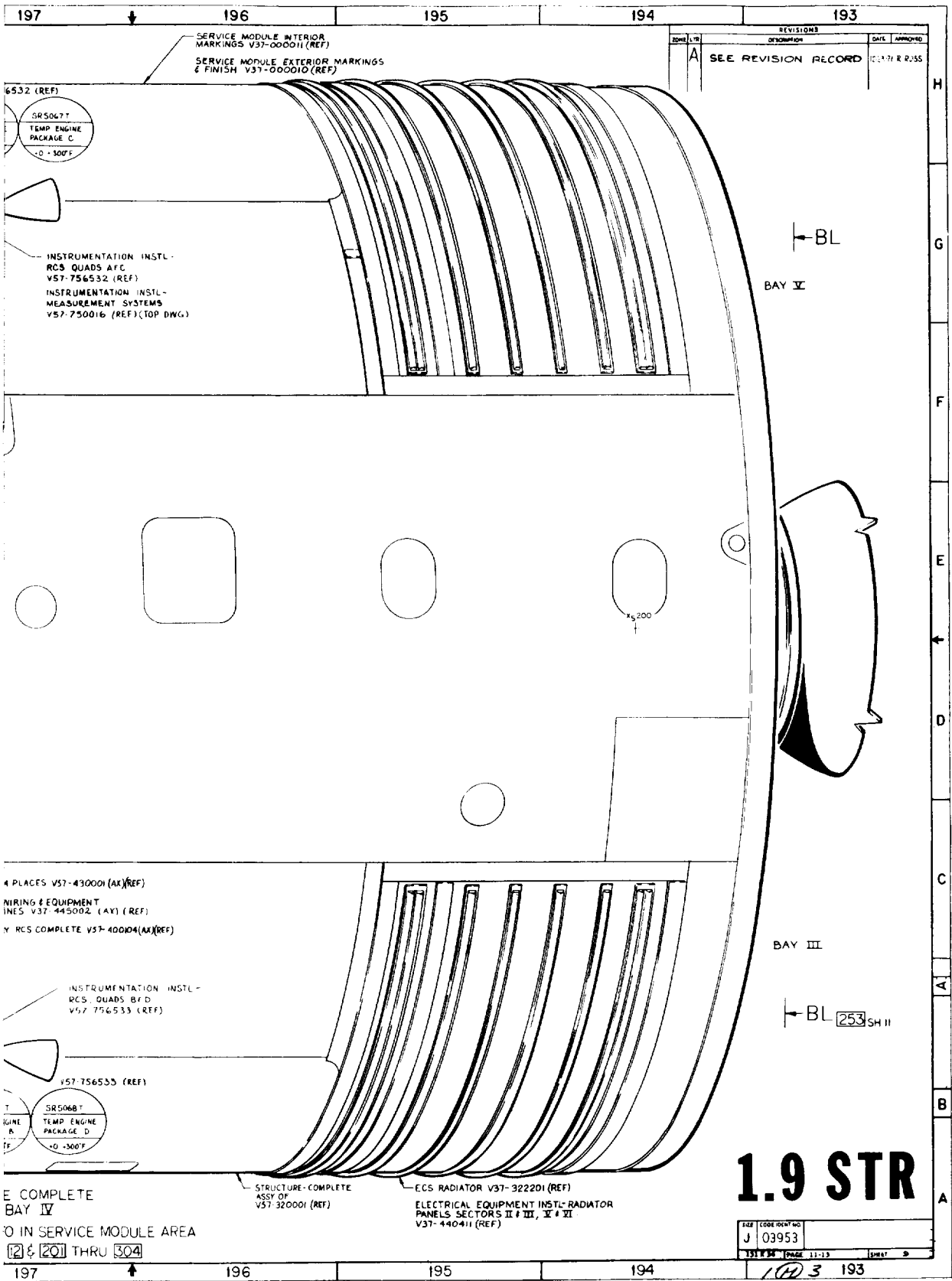

197      196      195      194      193

SERVICE MODULE INTERIOR MARKINGS V37-00001 (REF)  
 SERVICE MODULE EXTERIOR MARKINGS & FINISH V37-00010 (REF)

| REV | DESCRIPTION         | DATE     | APPROVED |
|-----|---------------------|----------|----------|
| A   | SEE REVISION RECORD | 12-27-71 | R. RUSS  |

6532 (REF)  
 SR50677  
 TEMP ENGINE PACKAGE C  
 +0 -300F

INSTRUMENTATION INSTL -  
 RCS QUADS A/F C  
 V57-756532 (REF)  
 INSTRUMENTATION INSTL -  
 MEASUREMENT SYSTEMS  
 V57-750016 (REF) (TOP DWG.)

← BL

BAY IV

4 PLACES V57-430001 (AX) (REF)  
 WIRING & EQUIPMENT  
 INES V37-445002 (AX) (REF)  
 Y RCS COMPLETE V57-400004 (AX) (REF)

INSTRUMENTATION INSTL -  
 RCS QUADS B/D  
 V57-756533 (REF)

BAY III

← BL 253 SH II

V57-756533 (REF)  
 SR50687  
 TEMP ENGINE PACKAGE D  
 +0 -300F

E COMPLETE  
 BAY IV  
 O IN SERVICE MODULE AREA  
 12 & 201 THRU 304

STRUCTURE COMPLETE  
 ASSY OF  
 V57-320001 (REF)

ECS RADIATOR V37-322201 (REF)  
 ELECTRICAL EQUIPMENT INSTL- RADIATOR  
 PANELS SECTORS II & III, V & VI  
 V37-440411 (REF)

**1.9 STR**

|          |               |
|----------|---------------|
| SIZE     | CODE IDENT NO |
| J        | 03953         |
| 193 # 34 | PAGE 11-13    |
| 193      | 3             |

197      196      195      194      193

**EQLDOUT FRAME 5**

01-14-2013

02-14-2013

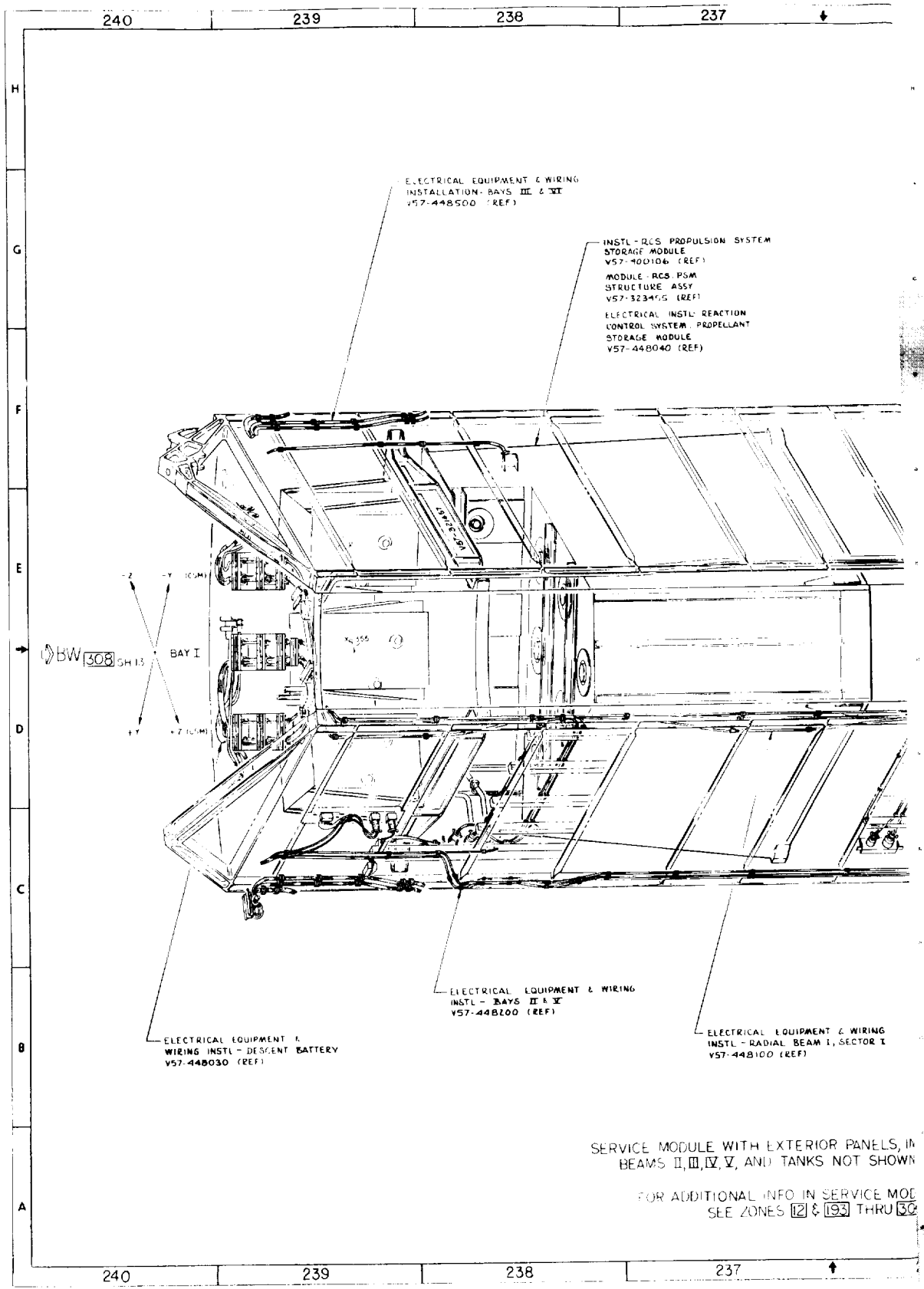

ELECTRICAL EQUIPMENT & WIRING  
 INSTALLATION - BAYS III & IV  
 V57-448500 (REF)

INSTL - RCS PROPULSION SYSTEM  
 STORAGE MODULE  
 V57-400106 (REF)  
 MODULE - RCS PSM  
 STRUCTURE ASSY  
 V57-323455 (REF)  
 ELECTRICAL INSTL - REACTION  
 CONTROL SYSTEM, PROPELLANT  
 STORAGE MODULE  
 V57-448040 (REF)

BW 308 SH 13

BAY I

ELECTRICAL EQUIPMENT & WIRING  
 INSTL - BAYS II & V  
 V57-448100 (REF)

ELECTRICAL EQUIPMENT &  
 WIRING INSTL - DESCENT BATTERY  
 V57-448030 (REF)

ELECTRICAL EQUIPMENT & WIRING  
 INSTL - RADIAL BEAM I, SECTOR I  
 V57-448100 (REF)

SERVICE MODULE WITH EXTERIOR PANELS, IN  
 BEAMS II, III, IV, V, AND TANKS NOT SHOWN

FOR ADDITIONAL INFO IN SERVICE MOD  
 SEE ZONES 12 & 193 THRU 30

**EOLDOUT FRAME /**

• 2019年12月31日

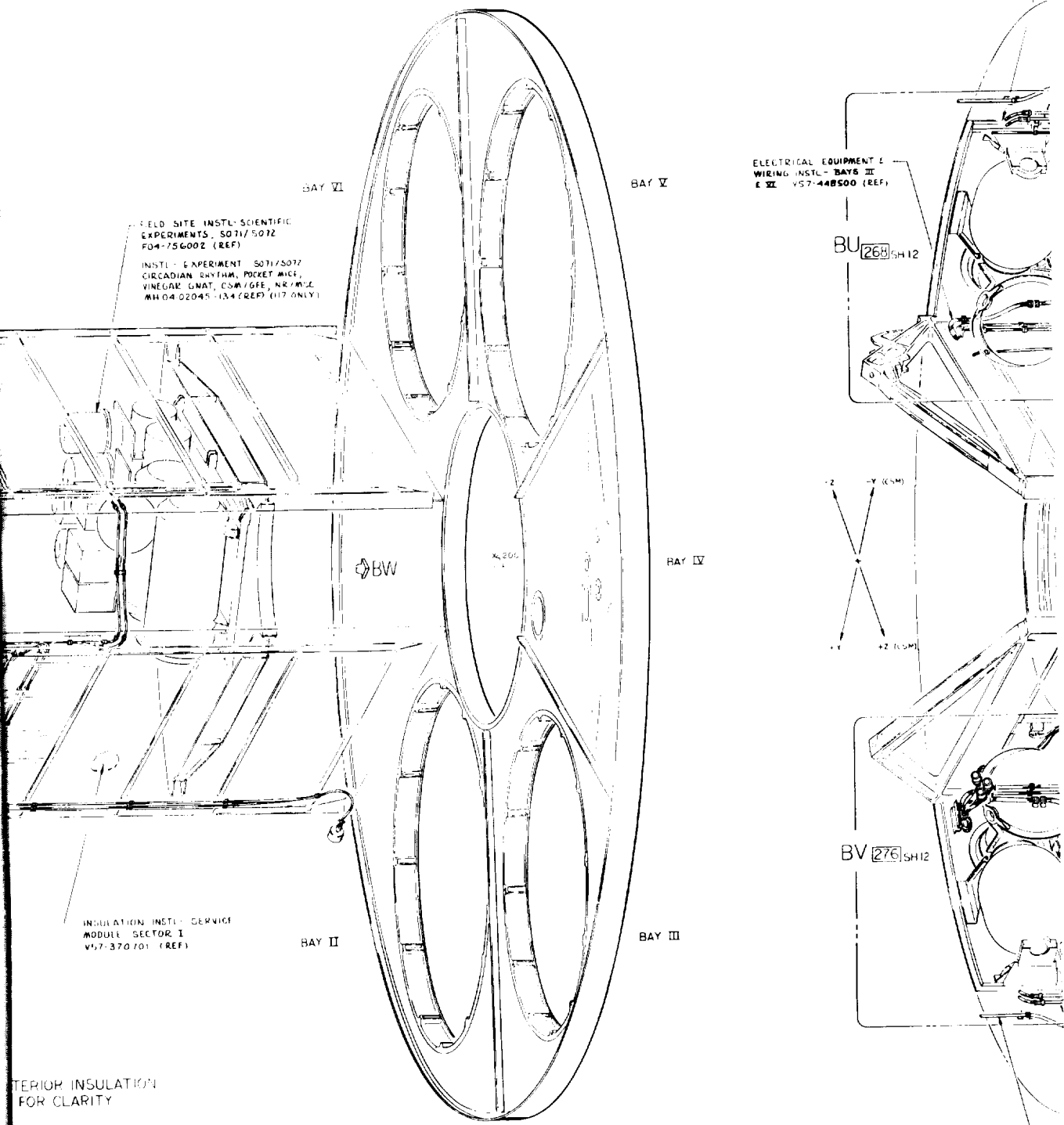

INTERIOR INSULATION FOR CLARITY  
MODULE AREA

FOLDOUT FRAME 2





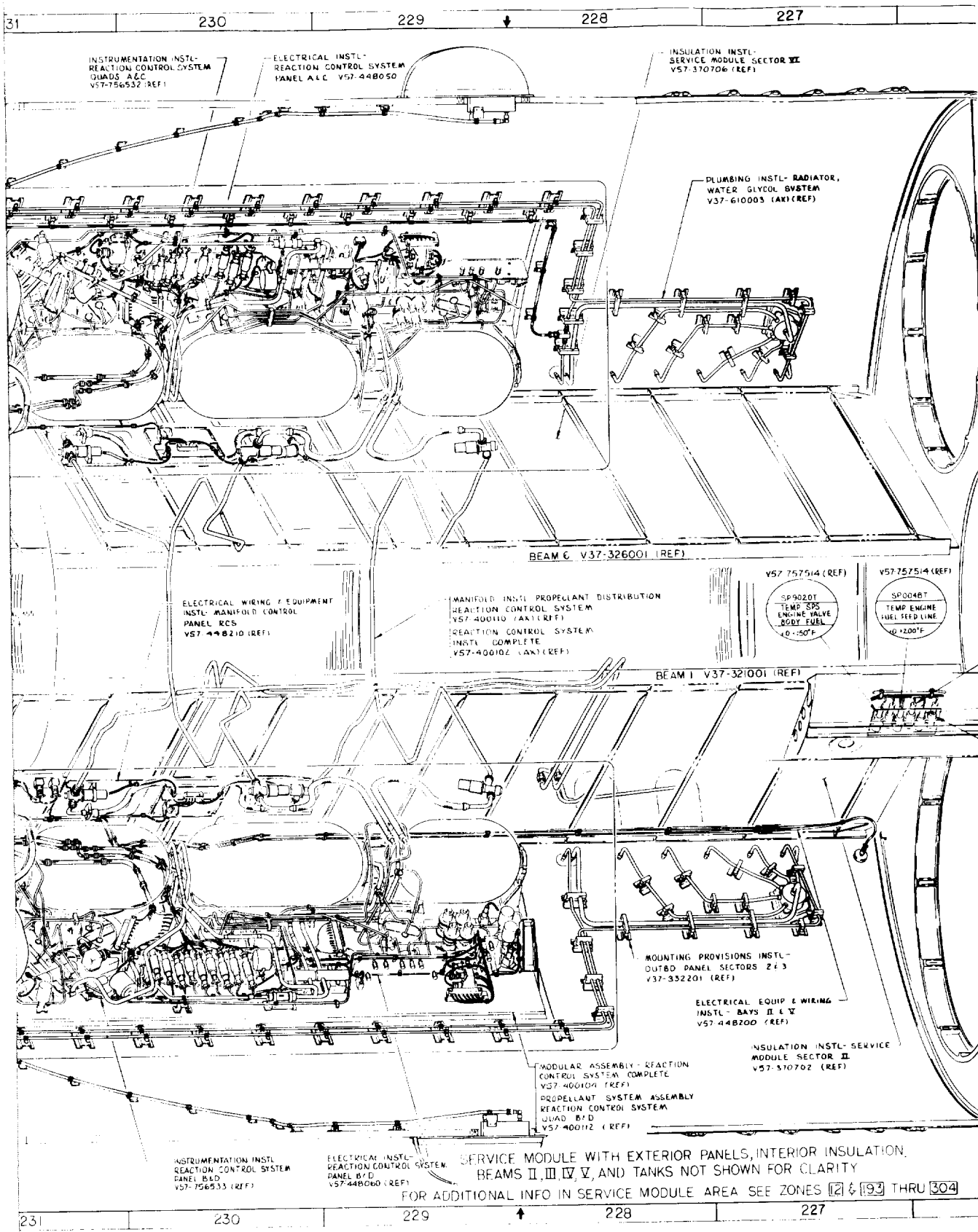

FOLDOUT FRAME 3

10/10/10

226

225

224

223

222

INSULATION INSTALLATION SERVICE  
MODULE SECTOR I  
V57-370705 (REF)

BEAM  
V57-32

BAY V

BAY VI

WATER STOR  
V57-338790

V57-757514 (REF)



V57-754515 (REF)



BAY IV



V57-757514 (REF)



HELIUM TANK INSTL  
V57-347108 (REF)

V57-757514 (REF)



BAY III

BAY II

STRUCTURE COMPLETE  
ASSY V57-320001 (REF)

SERVICE  
INSULAT

FOR A

226

225

224

223

222

221

REV 10 A

FOLDOUT FRAME 4



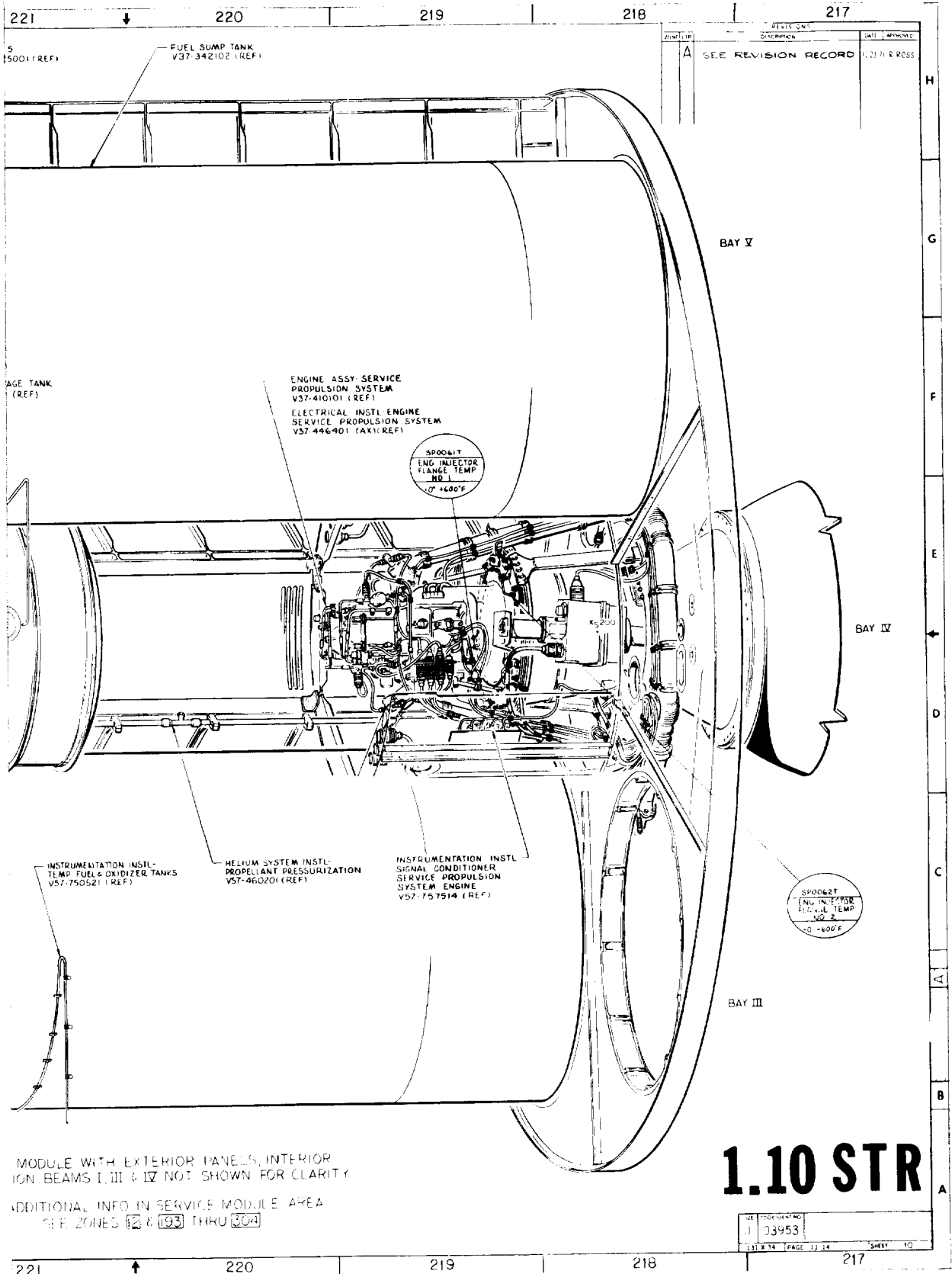

FOLDOUT FRAME 5



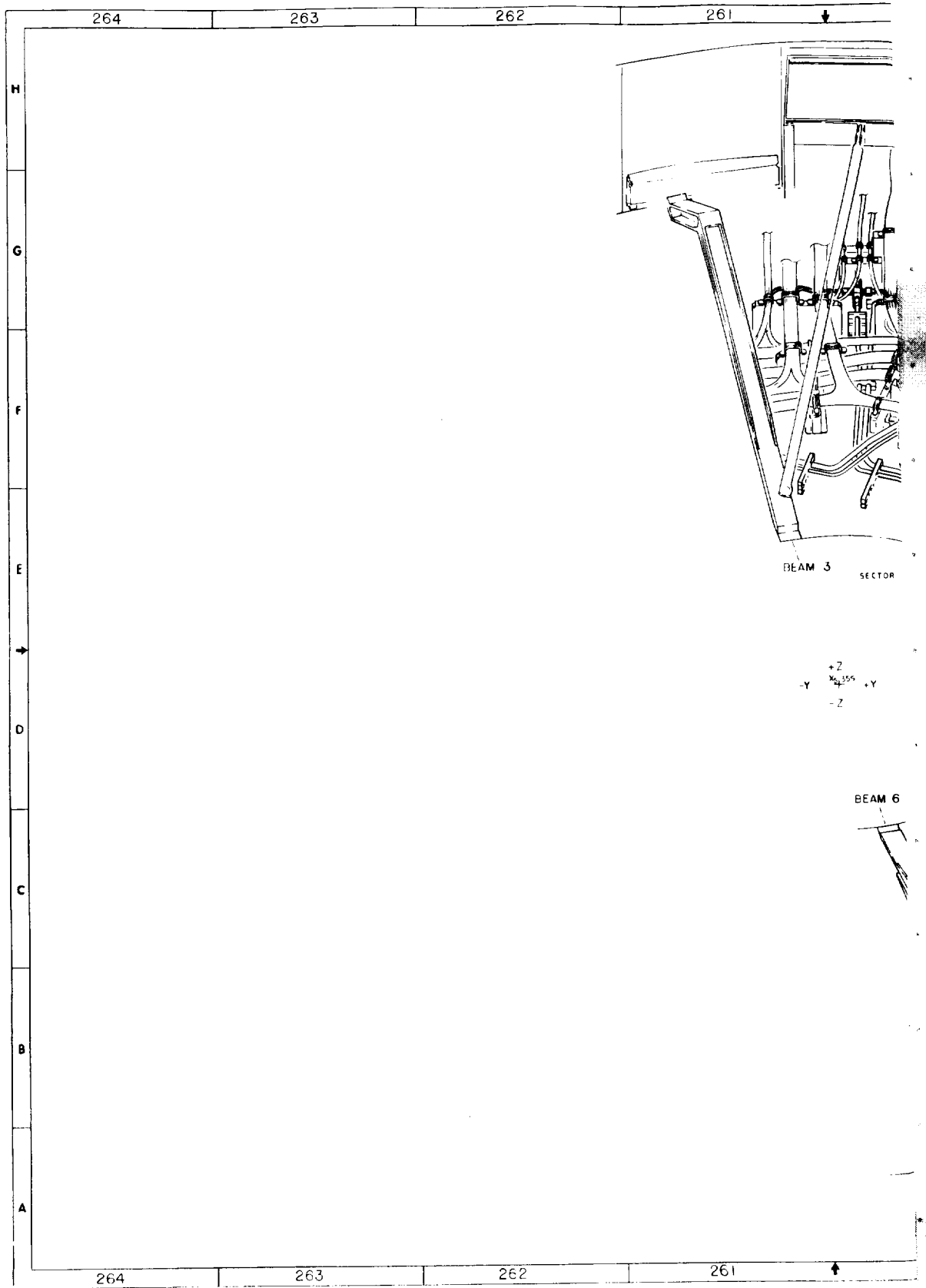

**FOLDOUT FRAME** /

1000



260

259

258

257

256

EQUIPMENT INSTL WATER BYCOL SYSTEM, FWD SHD  
V57-61020 (AX) (REF) SC 117 ONLY

CHANNEL 4

CHANNEL 3

CHANNEL 2

CHANNEL 1

BEAM 2

SECTOR 2

BEAM 1

SECTOR 1

CHANNEL 17

CHANNEL 16

CHANNEL 15

V57-759515 (REF)

SP 9016 T  
TEMP MID  
FEED LINE  
+0 -150°F

SERVICE PROPULSION  
SYSTEM COMPLETE  
V57-400201 (AX) (REF)

OXIDIZER DISTRIBUTION  
SYSTEM INSTL  
V57-410201 (AX) (REF)

FUEL AND OXIDIZER INSTRUMENTATION  
INSTL DISTRIBUTION SYS SPS  
V57-759515 (REF)

VIEW BY-BY 243 117 ONLY

260

259

258

257

256

FOLDOUT FRAME 2



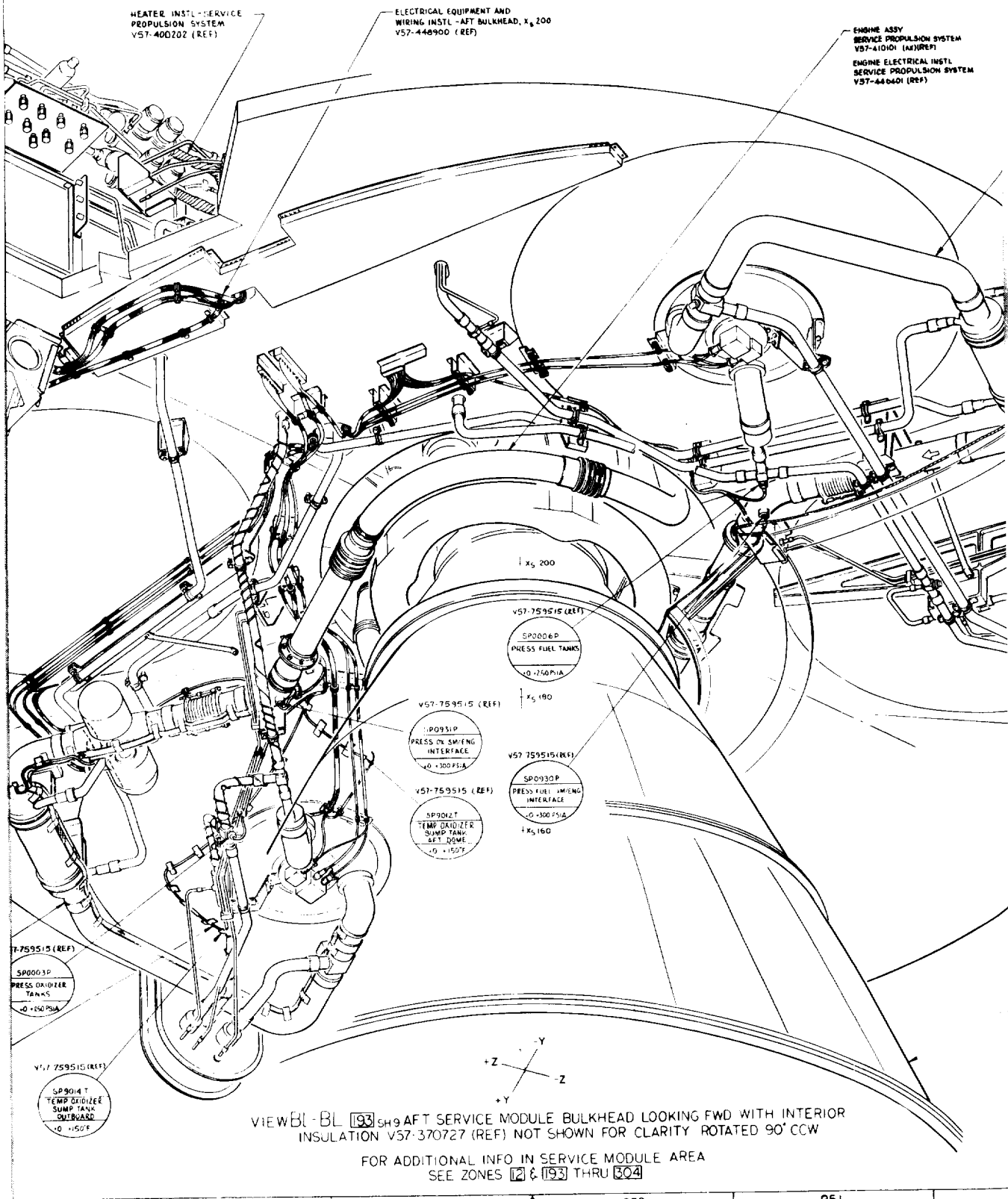

10/10/2020

250

249

248

247

246

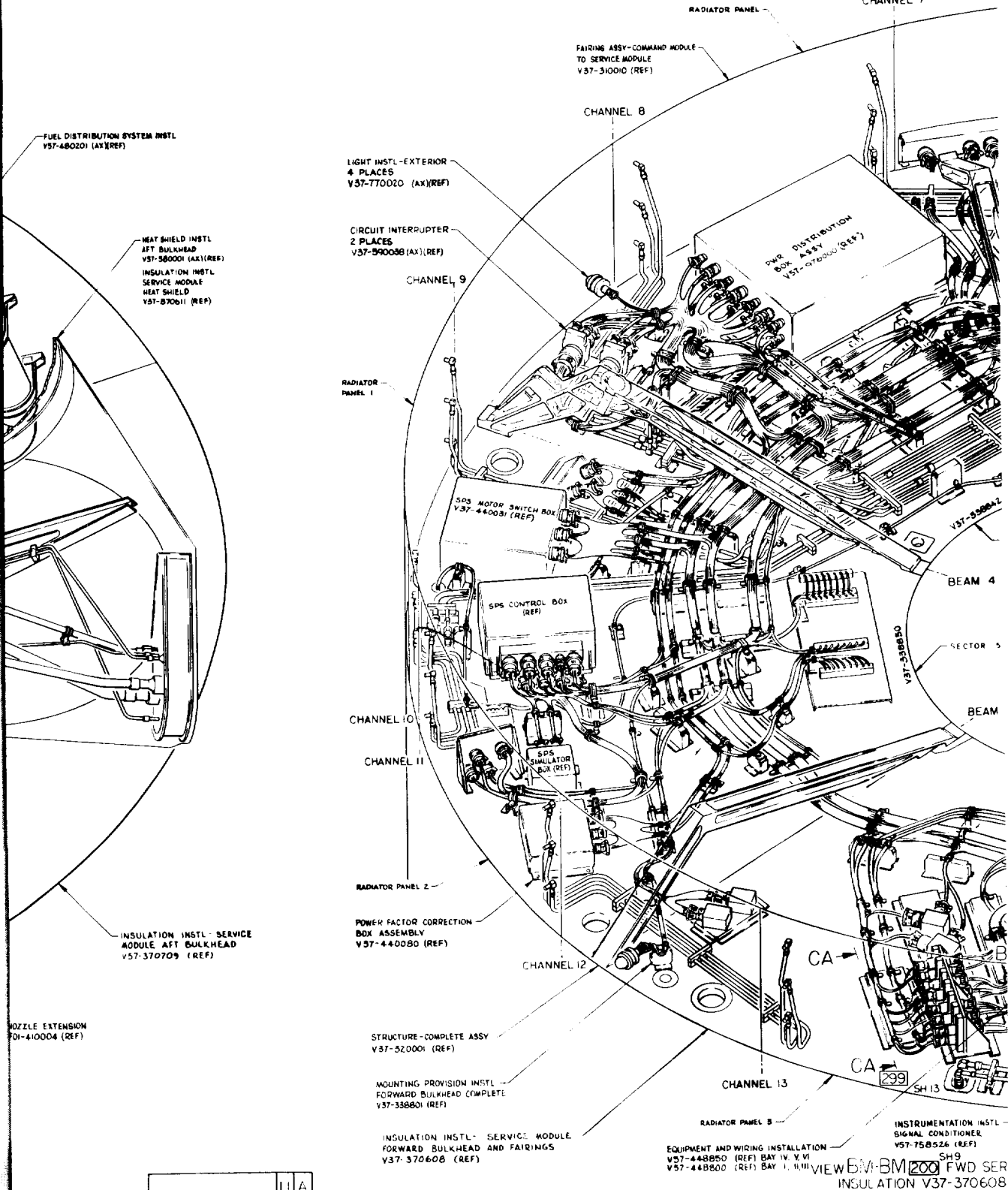

250

249

248

247

246

FOLDOUT FRAME 4



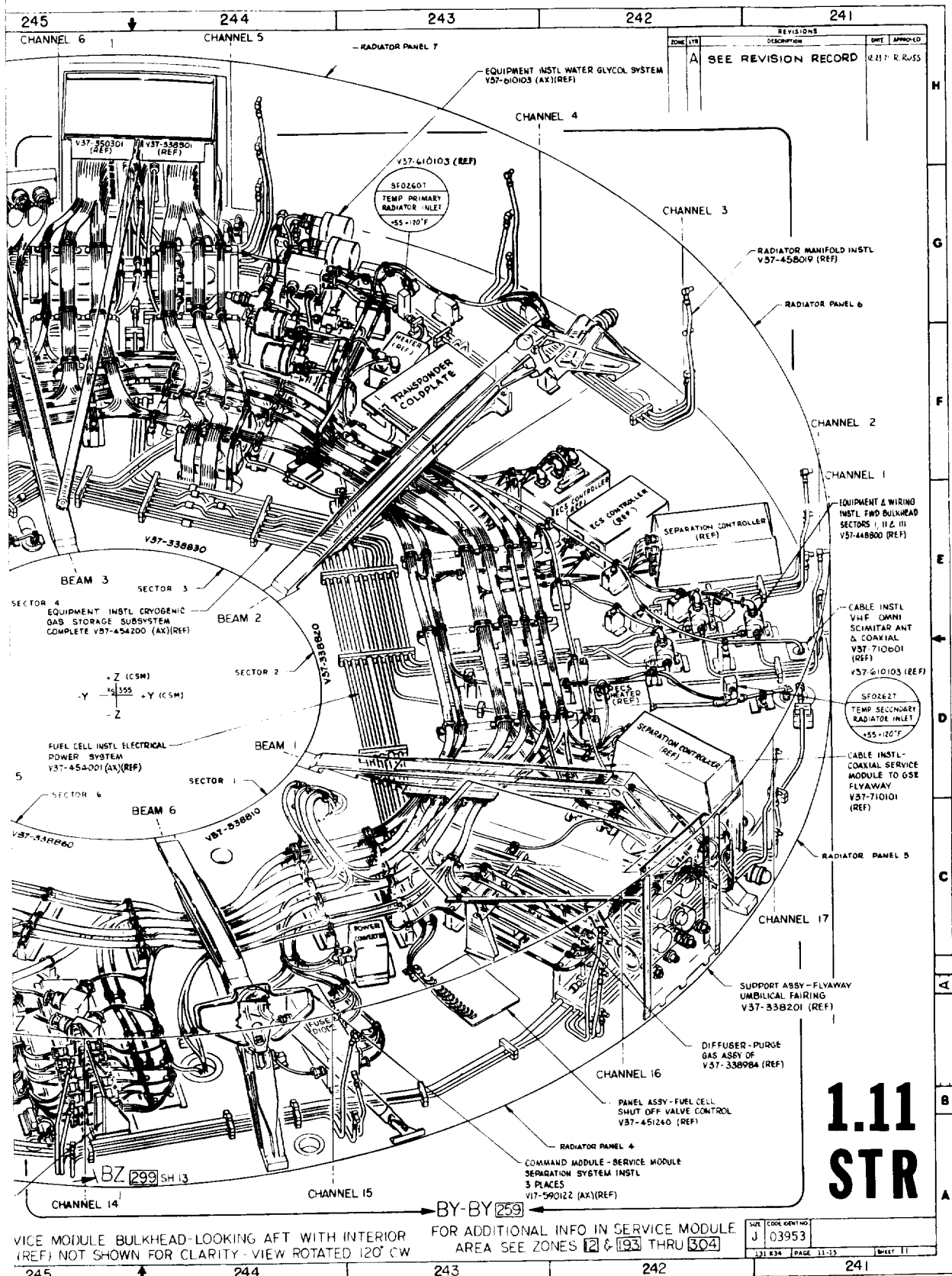

FOLDOUT FRAME 5

Small, faint, illegible markings or text at the bottom left corner of the page.



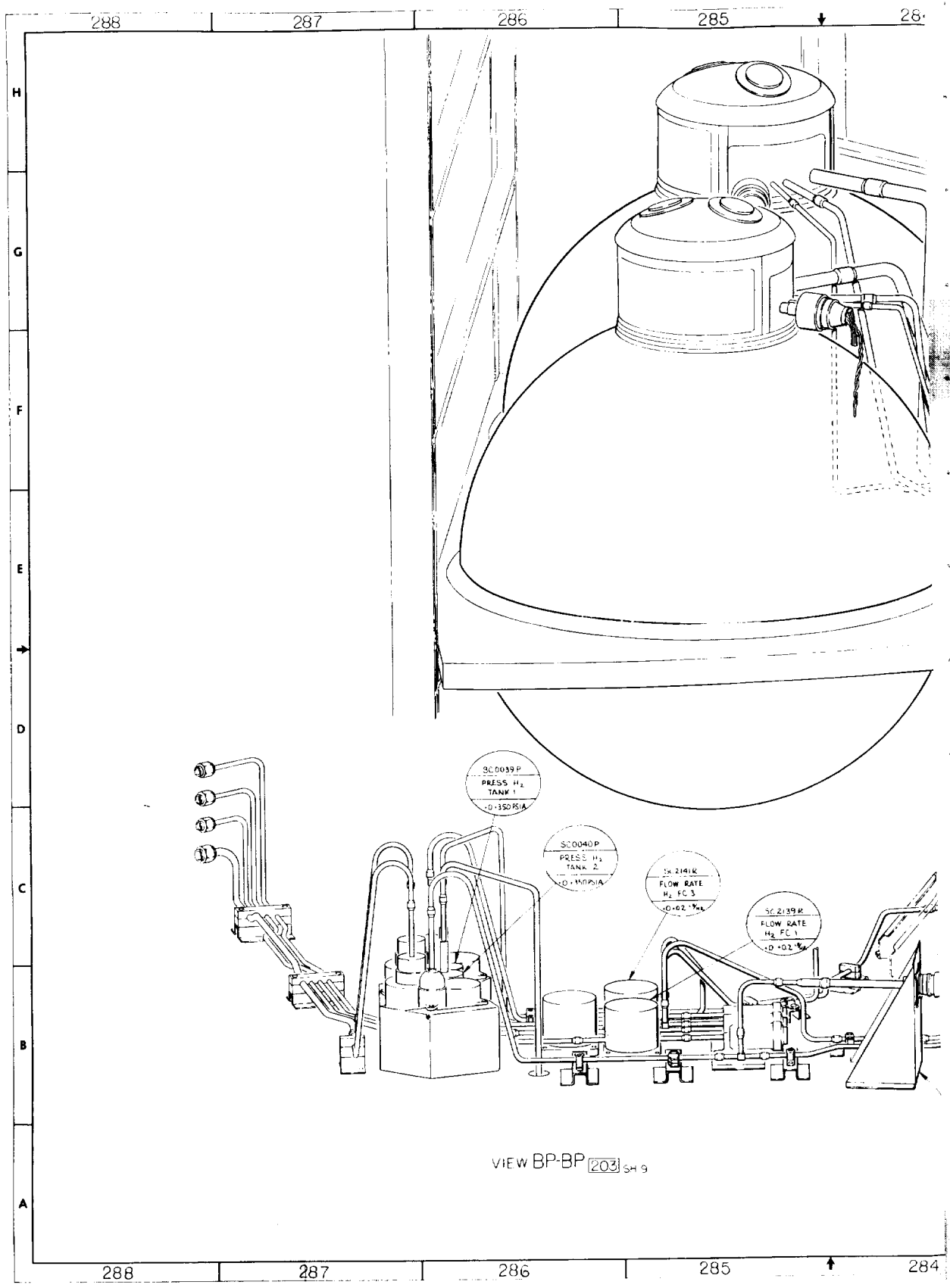

**FOLDOUT FRAME /**

1. 2. 3.

283

282

281

280

279

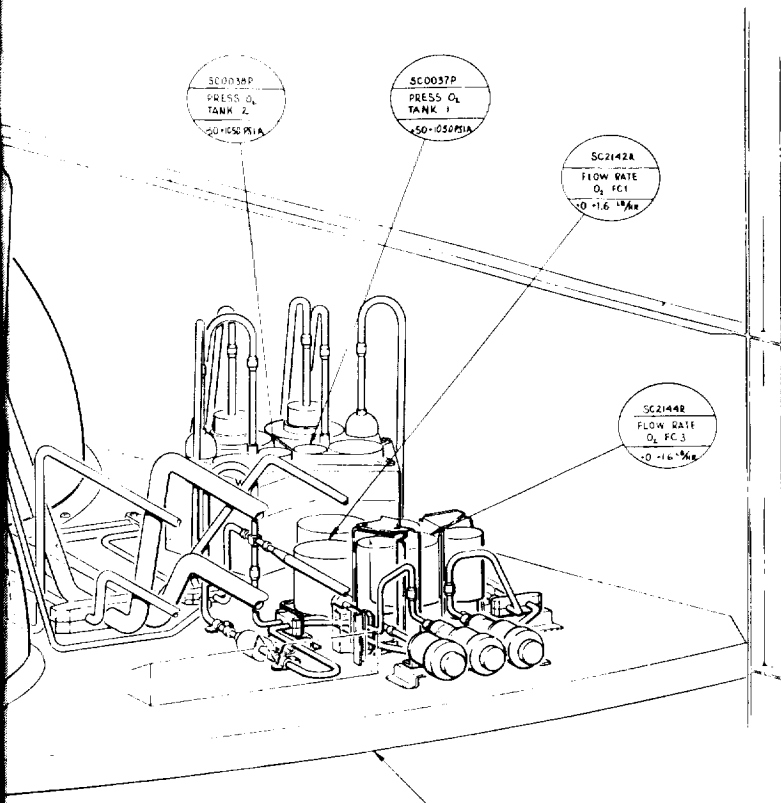

VIEW BR-BR [204] SH9

ROTATED 90° CLOCKWISE

EQUIPMENT SHELF INSTL -  
CRYOGENIC GAS STORAGE  
SYS OXYGEN  
V37-454201 (AX) (REF)

EQUIPMENT SHELF INSTL -  
CRYOGENIC GAS STORAGE  
SYSTEM HYDROGEN  
V37-454202

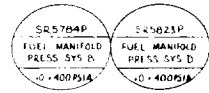
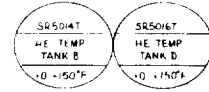

INSTRUMENTATION INSTL -  
REACTION CONTROL SYSTEM  
PANEL B&D  
V57-756533 (REF)

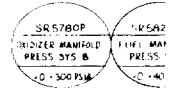

283

282

303 281

280

279

FOLDOUT FRAME 2



278

277

276

275

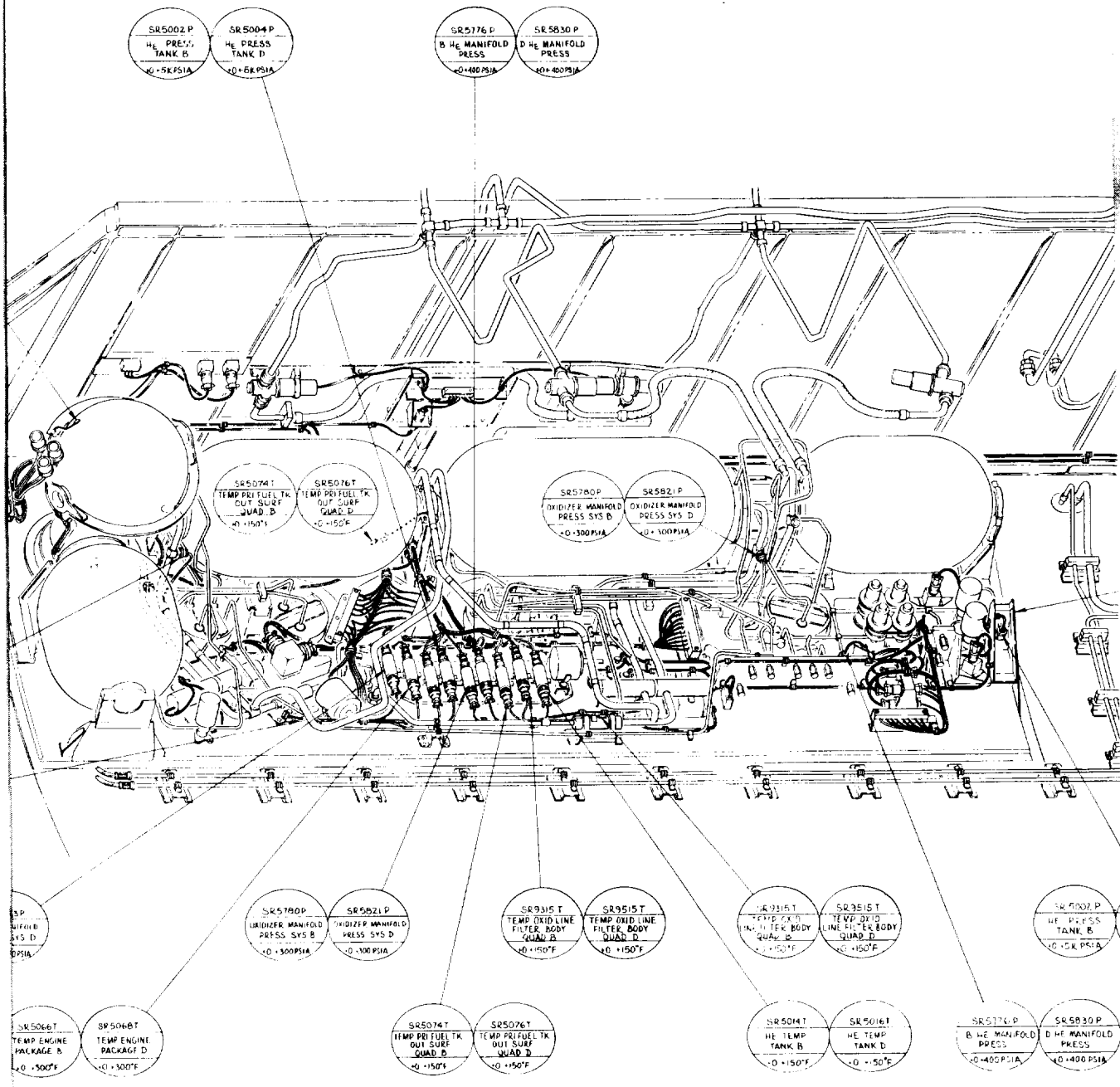

VIEW BV 232 SH 10

278

277

276

275

27

FOLDOUT FRAME 3





HEATER INSTL- REACTION  
CONTROL SYSTEM QUADS B&D  
V57-400171 (REF)  
(HEATER, NOT SHOWN FOR CLARITY)

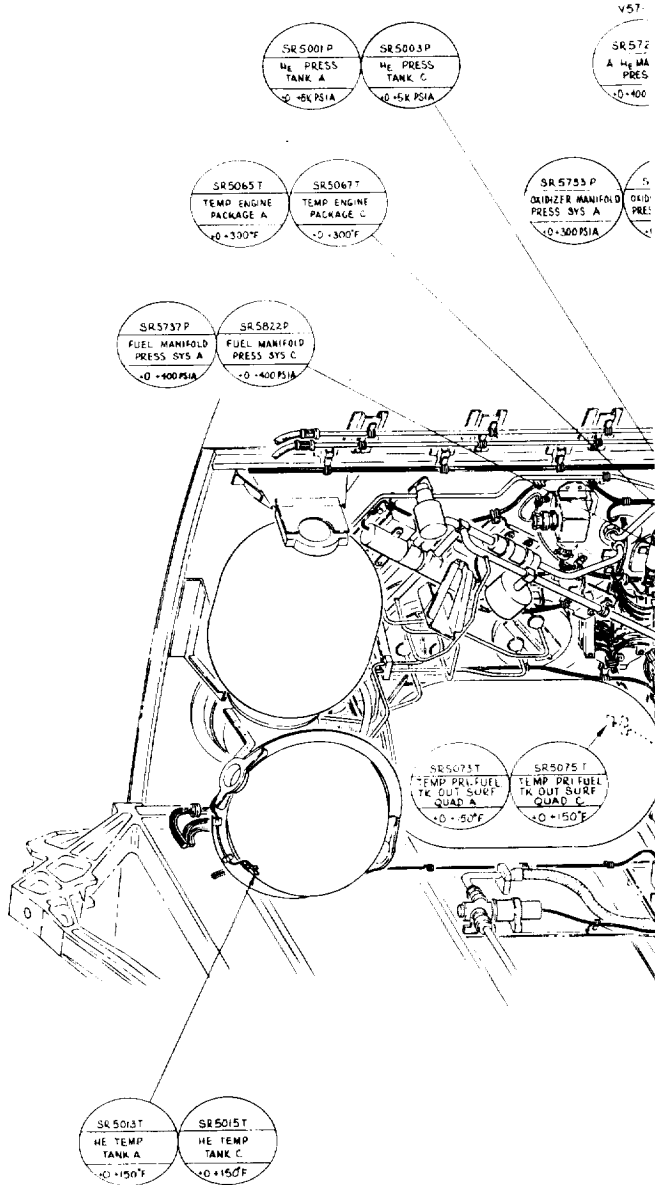





| ZONE |                     | REVISIONS | DATE | APPROVED |
|------|---------------------|-----------|------|----------|
| 1    | SEE REVISION RECORD |           |      |          |

756532 (TYPICAL REF)

SR5817P  
C<sub>2</sub>H<sub>4</sub> MANIFOLD PRESS  
+0 +400 PSIA

SR5073T  
TEMP PRI FUEL TK OUT SURF QUAD A  
+0 +150°F

SR5075T  
TEMP PRI FUEL TK OUT SURF QUAD C  
+0 +150°F

SR5820P  
OXIDIZER MANIFOLD PRESS SYS C  
+0 +300 PSIA

SR9215T  
TEMP OXID LINE FILTER BODY QUAD A  
+0 +150°F

SR9415T  
TEMP OXID LINE FILTER BODY QUAD C  
+0 +150°F

SR5729P  
A HE MANIFOLD PRESS  
+0 +400 PSIA

SR5817P  
C HE MANIFOLD PRESS  
+0 +400 PSIA

SR5001P  
HE PRESS TANK A  
+0 +5K PSIA

SR5003T  
HE PRESS TANK C  
+0 +5K PSIA

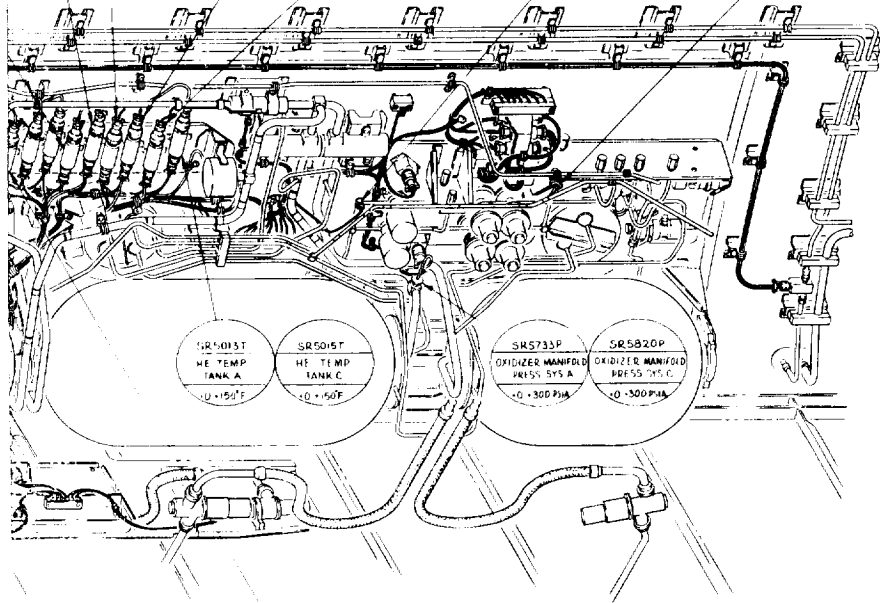

INSTRUMENTATION INSTL  
REACTION CONTROL SYSTEM  
QUADS A/C  
V57 756532 (REF)

VIEW BU [232] SH 10

# 1.12 STR

|          |                 |
|----------|-----------------|
| DATE     | 0004 08 14 1960 |
| J        | 03953           |
| 131 X 34 | PAGE 11-16      |
|          | SHEET 12        |

1. The first part of the document discusses the importance of maintaining accurate records of all transactions and activities. It emphasizes that this is crucial for ensuring transparency and accountability in the organization's operations.

2. The second part of the document outlines the various methods and tools used to collect and analyze data. It highlights the need for consistent and reliable data collection processes to support informed decision-making.

3. The third part of the document focuses on the role of technology in modern data management. It discusses how advanced software solutions can streamline data collection, storage, and analysis, leading to more efficient and effective operations.

4. The final part of the document provides a summary of the key findings and recommendations. It stresses the importance of ongoing monitoring and evaluation to ensure that the data management processes remain up-to-date and effective.

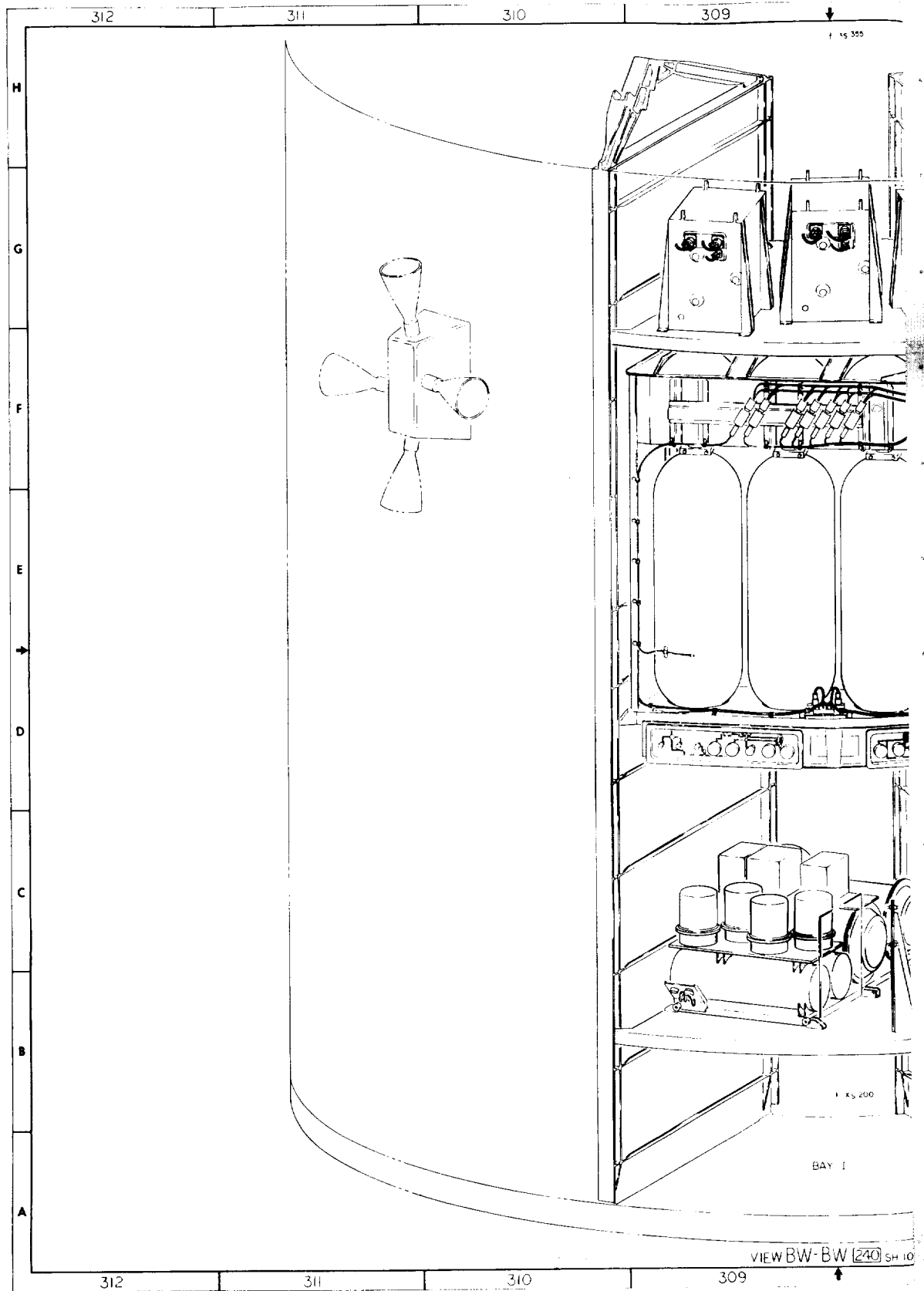

**FOLDOUT FRAME |**

1000

308

307

306

305

304

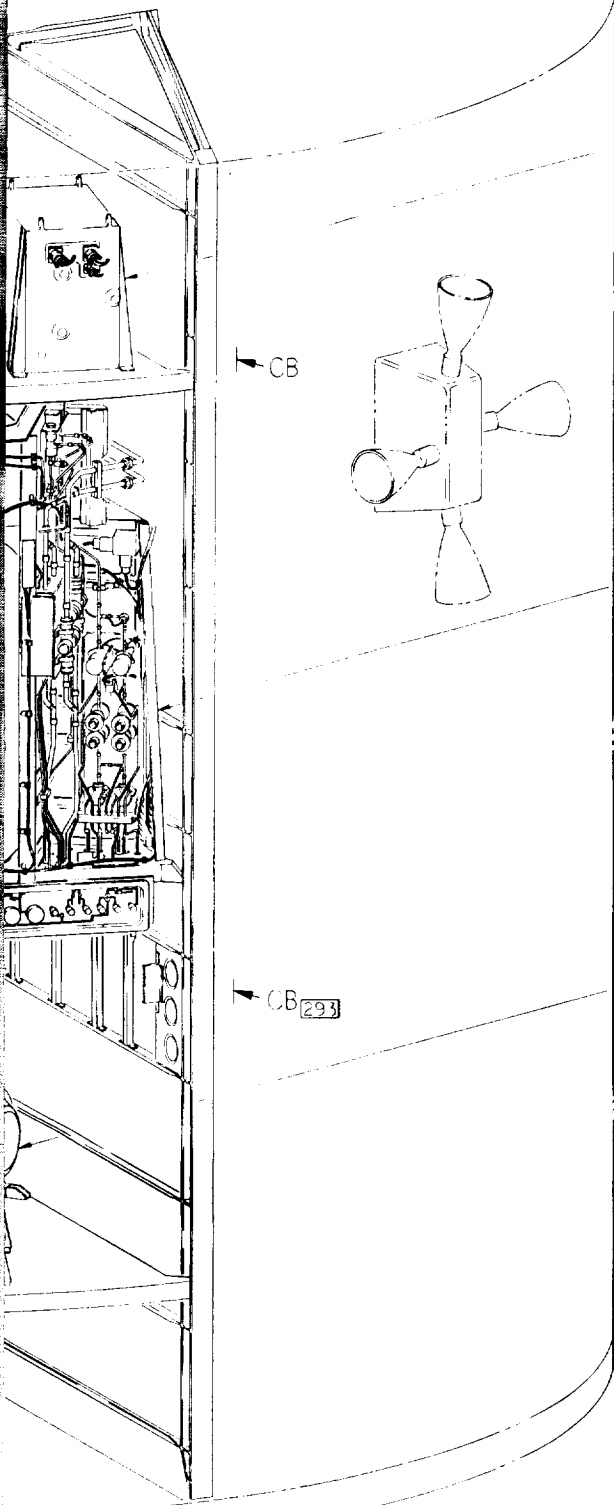

INSTALLATION PROVISIONS  
 BATTERY BAY 1  
 V57-331454 (REF)  
 BATTERY, STORAGE, SILVER  
 OXIDE-ZINC, 29 VOLT  
 ST 4610009 ME

INSTL RCS PROPULSION SYSTEM  
 STORAGE MODULE  
 V57-400106 (REF)  
 MODULE - RCS, PSM  
 STRUCTURE ASSY  
 V57-323455 (REF)  
 ELECTRICAL INSTL - RCS  
 PROPELLANT STORAGE MODULE  
 V57-448040 (REF)

FIELD SITE INSTL - SCIENTIFIC  
 EXPERIMENTS, S071/S072  
 F04-756002 (REF)  
 INSTL - EXPERIMENT S071/S072,  
 CIRCADIAN RHYTHM, POCKET MICE,  
 VINEGAR GNAT, CSM/GFE, NR/MSC  
 MH 04-02045-134 (REF) (17 ONLY)

PLUMBING INSTL - RADIATOR  
 WATER GLYCOL SYS  
 V57-610008 (REF)

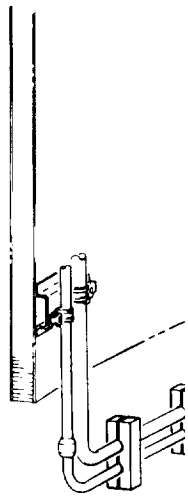

308

307

306

305

304

FOLDOUT FRAME 2

1999.09.09

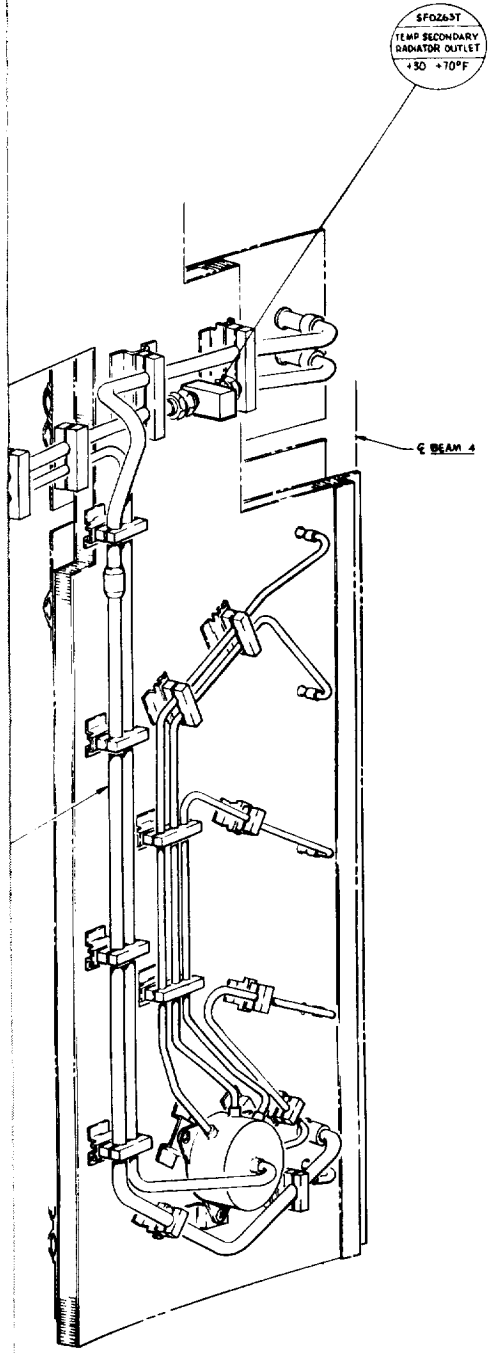

VIEW BN-BN 202 SH 9

SFO263T  
TEMP SECONDARY  
RADIATOR OUTLET  
+50 +70°F

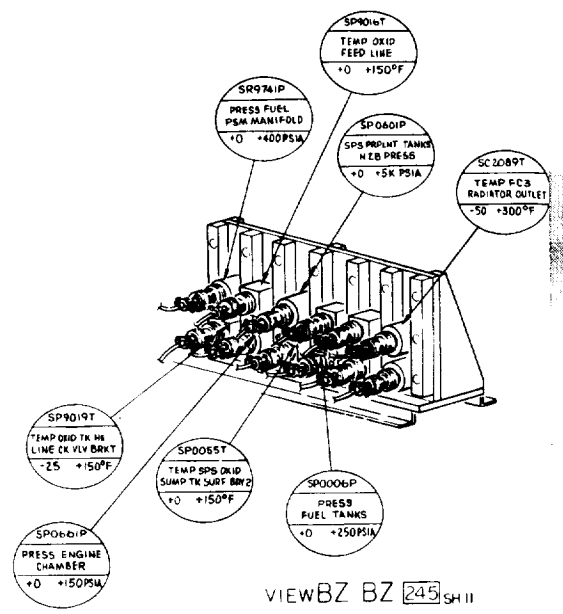

VIEW BZ BZ 245 SH II

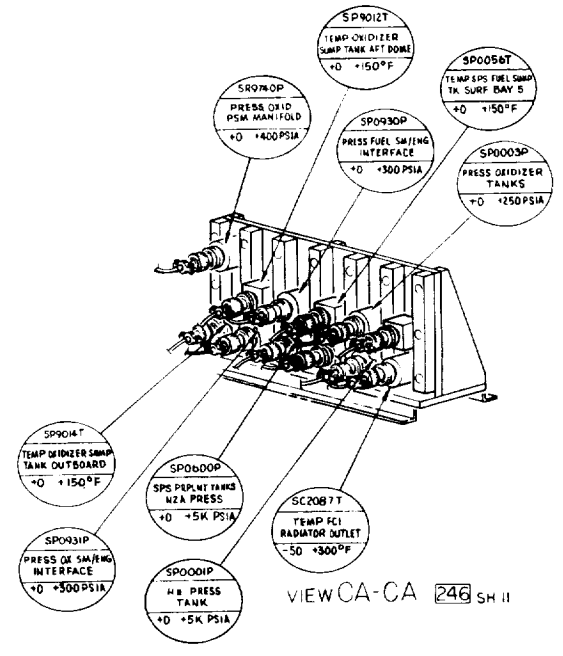

VIEW CA-CA 246 SH II

SFO263T  
TEMP OXID  
FEED LINE  
+0 +150°F

SR9761P  
PRESS FUEL  
PSM MANIFOLD  
+0 +400PSIA

SPO601P  
SPS PRELINT TANKS  
N2A PRESS  
+0 +5K PSIA

SC2089T  
TEMP FC3  
RADIATOR OUTLET  
-50 +300°F

SPO191T  
TEMP OXID TK IN  
LINE CK VLV BRKT  
-25 +150°F

SPO055T  
TEMP SPS OXID  
SUMP TK SURF BRKT  
+0 +150°F

SPO006P  
PRESS  
FUEL TANKS  
+0 +250PSIA

SPO661P  
PRESS ENGINE  
CHAMBER  
+0 +150PSIA

SPO102T  
TEMP OXIDIZER  
SUMP TANK AT BOWE  
+0 +150°F

SPO056T  
TEMP SPS FUEL SUMP  
TK SURF BAY 5  
+0 +150°F

SPO790P  
PRESS OXID  
PSM MANIFOLD  
+0 +400PSIA

SPO930P  
PRESS FUEL SW/ING  
INTERFACE  
+0 +300PSIA

SPO003P  
PRESS OXIDIZER  
TANKS  
+0 +250PSIA

SPO141T  
TEMP OXIDIZER SUMP  
TANK OUTBOARD  
+0 +150°F

SPO660P  
SPS PRELINT TANKS  
N2A PRESS  
+0 +5K PSIA

SC2087T  
TEMP FC1  
RADIATOR OUTLET  
-50 +300°F

SPO931P  
PRESS OF SW/ING  
INTERFACE  
+0 +300PSIA

SPO001P  
H2 PRESS  
TANK  
+0 +5K PSIA





CC

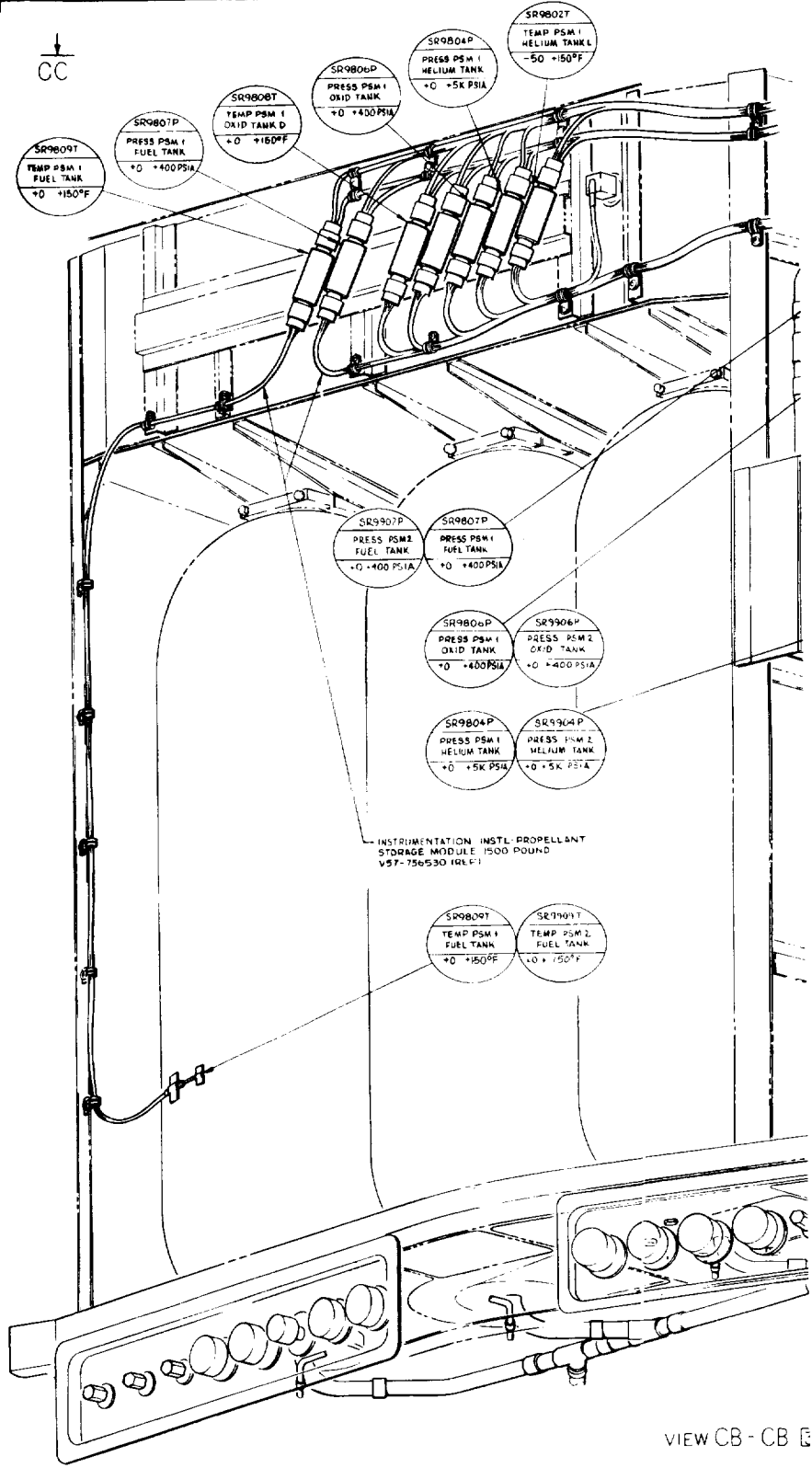

VIEW CB - CB E

FOLDOUT FRAME 4



| ZONE |  | REV | DESCRIPTION         | DATE     | APPROVED |
|------|--|-----|---------------------|----------|----------|
| A    |  |     | SEE REVISION RECORD | 12/25/71 | R ROSS   |

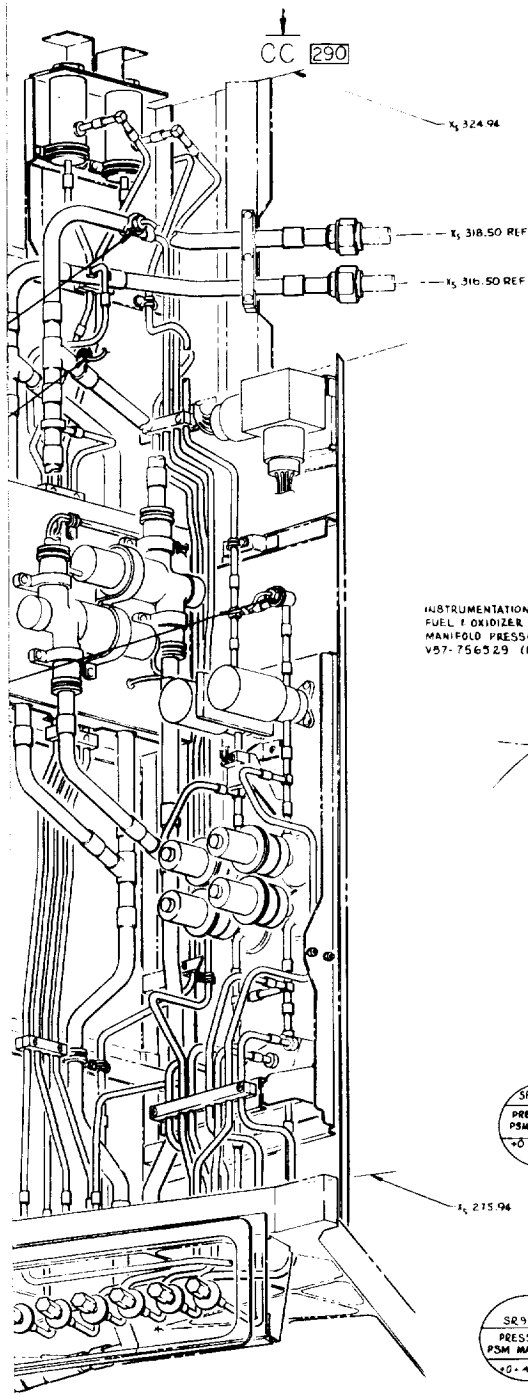

INSTRUMENTATION INSTL  
FUEL / OXIDIZER  
MANIFOLD PRESSURE  
V57-756529 (REF)

SR9902T      SR9802T  
TEMP PSM 2      TEMP PSM 1  
HELIUM TANK L      HELIUM TANK L  
-50 +150°F      -50 +150°F

SR9740P      SR9808T      SR9908T  
PRESS OXID      TEMP PSM 1      TEMP PSM 2  
PSM MANIFOLD      OXID TANK D      OXID TANK D  
+0 +400PSIA      +0 +150°F      +0 +150°F

SR9741P  
PRESS FUEL  
PSM MANIFOLD  
+0 +400PSIA

VIEW CC-CC 292  
ROTATED CW 45°  
LOOKING AFT

# 1.13 STR

