

DCT5100

Quick Start

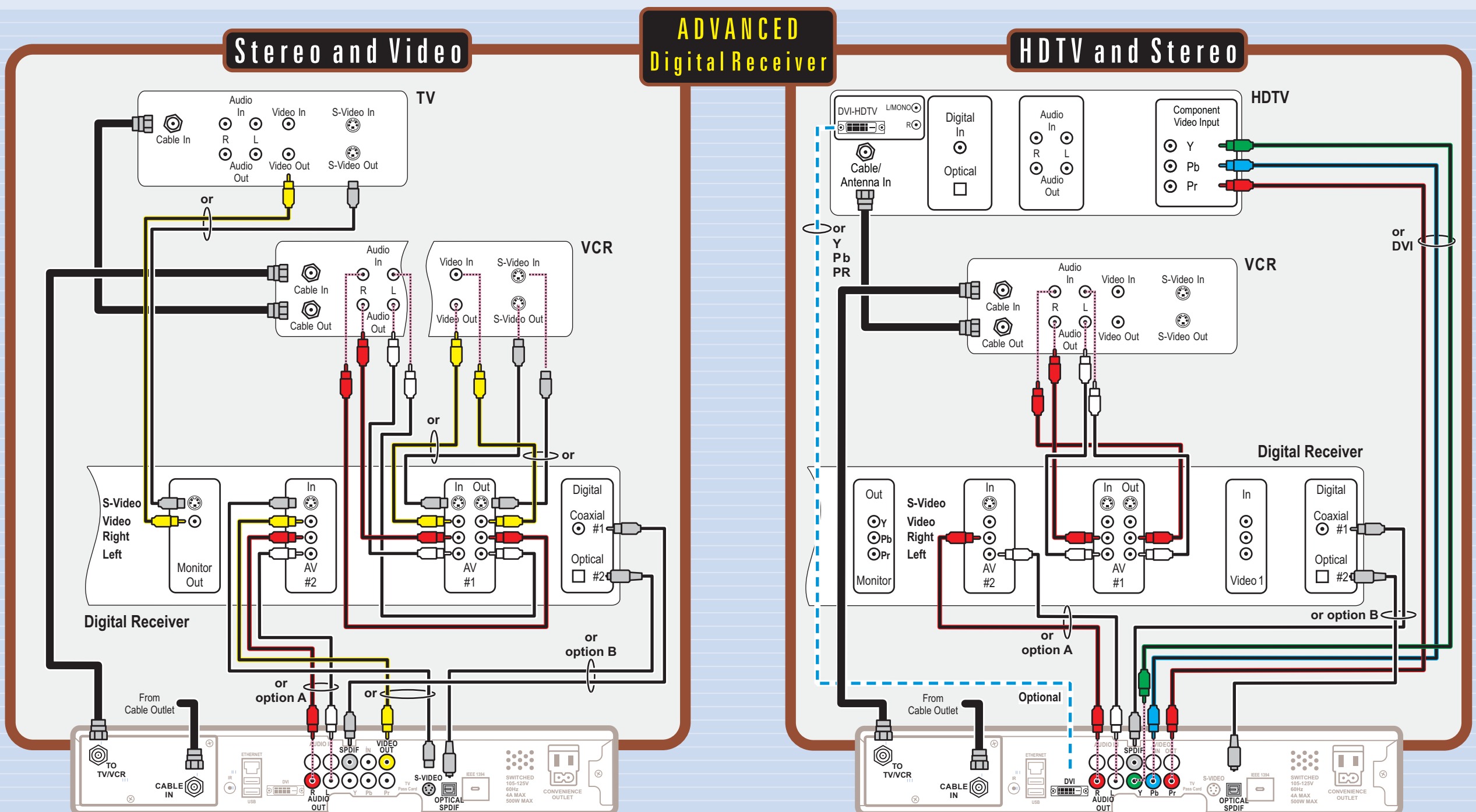

A Quick Start Guide for connecting your DCT5100. Choose the configuration that best suits your home entertainment needs.

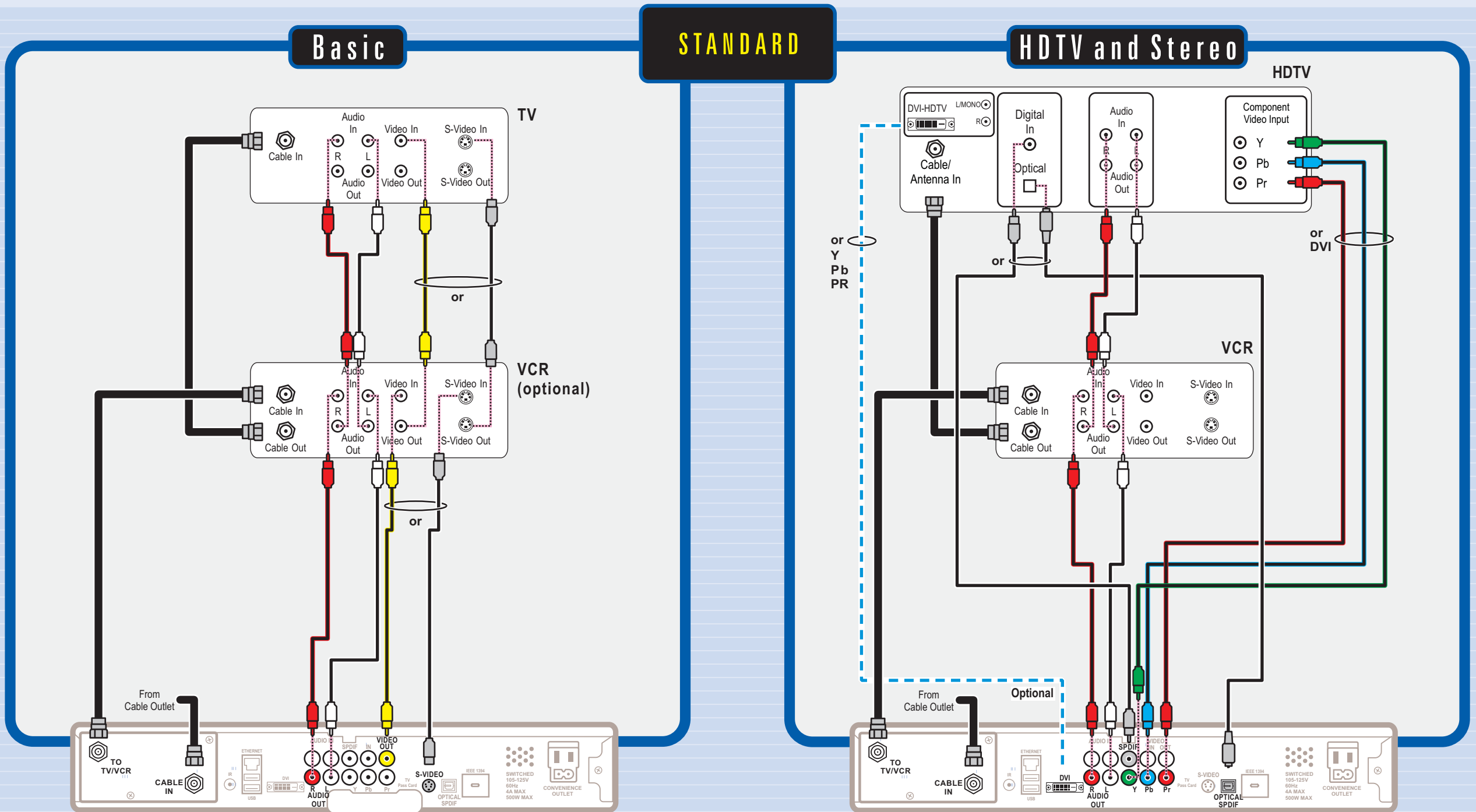

If your DCT5100 and HDTV have optional DVI connections, connect to your HDTV using the DVI cable. Be sure to connect the left and right audio cables to the DVI L/Mono and R jacks on the TV. For more detailed information, refer to the DCT5100 User Guide. Please see the Important Safety Instructions on reverse.

DCT5100

Quick Start



Important Safety Instructions

Be sure to allow adequate ventilation and airflow around the DCT5100 to prevent overheating.

- ▶ Position the DCT5100 with at least 2 inches of space above and on all sides.
- ▶ Do not block the slots and openings in DCT5100.
- ▶ Do not place anything on top of the DCT5100.



- ▶ Do not position the DCT5100 in an enclosed space that would restrict airflow around the unit.
- ▶ Do not position the DCT5100 near any external heat source that could raise the temperature around the unit.

Set-up Configuration

Use the on-screen display menu to configure your video display and closed caption settings.

To access your configuration settings, press the MENU key on the front panel or your remote control while the DCT5100 is turned off. If your TV is on, the on-screen display menu appears listing the settings you can configure. The user settings will also be displayed on the front panel LED whether your TV is off or on.

When you first access the on-screen display, your TV screen may appear blank if your DCT5100 is not set at the correct video display format. You can still view your settings on the front panel LED (see below).

Use your remote control or the cursor keys on the front panel to navigate the on-screen display:

- Press the ▲ and ▼ keys to highlight the settings you wish to change.
- Press the ► key to select an option for that setting.
- To exit the setting and move to another setting, use the ▲ and ▼ keys.

When you are finished configuring your settings turn the DCT5100 back on.

For more information on configuration settings, refer to the DCT5100 User Guide.

Select video display format:

Use ▲ key to highlight OUTPUT TYPE

Use ► key to select option

Use ▼ key to highlight SAVE CHANGES

Use ► key to select option

If you are not using the HDTV connections, selecting an Output Type other than 480I will cause the on-screen display to go blank, but you can still view your settings on the LED.

Enable or disable closed caption:

Use ▲ key to highlight CLOSED CAPTION

Use ► key to select option

Use ▼ key to highlight SAVE CHANGES

Use ► key to select option

Before calling your service provider, review the troubleshooting guide.

This information is to help you quickly solve the problem. If your problem still exists, contact your service provider.

Troubleshooting:

Problem	Cause	Possible Solution
No sound	Accidentally pressed MUTE on the remote control. The stereo is tuned to the wrong entertainment component. You are watching TV using your VCR, and your VCR is off.	Press MUTE on the remote control to restore the volume level. Check that the stereo is looking at the proper input source. Turn your VCR on.
No picture	Cable signal may not be reaching your home.	Check to be sure that all cables are connected properly and that your TV is tuned to the cable channel 3 or 4. Hand-tighten the cable connections if necessary. If connected through the baseband RCA video connection, make sure the cables are connected properly. If you are watching TV using your VCR, be sure your VCR is on. Ensure that the proper video display format for your TV has been selected.
Picture or sound is noisy on one channel	Coaxial cable is disconnected or loose.	Reconnect the cable and hand-tighten if loose.
Sound from only one stereo speaker	Cable connections are disconnected or loose.	Hand-tighten or reconnect the cables properly. Ensure that wires are not frayed and plugs are not bent or broken.
No power	Power cord is disconnected.	Reconnect the power cord. Ensure that the DCT5100 is plugged into an outlet that is always live.
Remote control does not work	Remote isn't set in cable TV mode. Obstruction between remote and cable terminal. Dead batteries.	Press CABLE on the remote control. Ensure that nothing is on the DCT5100 or blocking a clear line of sight between it and the remote control. Change the batteries in your remote control according to the instructions in the section, "Installing Batteries."
Poor audio quality	Audio levels on external devices not set relative to DCT5100 volume level.	For best audio quality, use the remote control to set the DCT5100 to approximately ¾ of maximum volume level and then adjust the audio levels on the external devices.