

Galaxy VS

Maintenance Bypass Cabinet with/without Transformer

Installation

GVSBPOT100T, GVSBP100T
4/2020



Legal Information

The Schneider Electric brand and any trademarks of Schneider Electric SE and its subsidiaries referred to in this guide are the property of Schneider Electric SE or its subsidiaries. All other brands may be trademarks of their respective owners.

This guide and its content are protected under applicable copyright laws and furnished for informational use only. No part of this guide may be reproduced or transmitted in any form or by any means (electronic, mechanical, photocopying, recording, or otherwise), for any purpose, without the prior written permission of Schneider Electric.

Schneider Electric does not grant any right or license for commercial use of the guide or its content, except for a non-exclusive and personal license to consult it on an "as is" basis. Schneider Electric products and equipment should be installed, operated, serviced, and maintained only by qualified personnel.

As standards, specifications, and designs change from time to time, information contained in this guide may be subject to change without notice.

To the extent permitted by applicable law, no responsibility or liability is assumed by Schneider Electric and its subsidiaries for any errors or omissions in the informational content of this material or consequences arising out of or resulting from the use of the information contained herein.



Go to
https://www.productinfo.schneider-electric.com/portals/ui/galaxyvs_ui/
or scan the QR code above for digital experience and translated manuals.

Table of Contents

Important Safety Instructions — SAVE THESE	
INSTRUCTIONS	5
FCC Statement	6
Safety Precautions	6
Additional Safety Precautions After Installation.....	8
Electrical Safety	8
Specifications	9
Specifications for Maintenance Bypass Cabinet with Output Transformer (GVSBPOT100T)	9
Specifications for Maintenance Bypass Cabinet without Transformer (GVSBP100T) 480 V.....	12
Specifications for Maintenance Bypass Cabinet without Transformer (GVSBP100T) 208 V.....	14
Recommended Bolt and Lug Sizes	16
Torque Specifications.....	17
Weights and Dimensions.....	17
Clearance	18
Environment.....	18
System Overview	19
Installation Procedure for Maintenance Bypass Cabinet with Output Transformer (GVSBPOT100T)	21
Installation Procedure for Maintenance Bypass Cabinet without Transformer (GVSBP100T).....	22
Receiving	24
Unpack the Maintenance Bypass Cabinet	25
Prepare for Installation	28
Install the Optional Kit for Dual Mains (GVSOPT031).....	31
Install the Seismic Anchoring (Option)	33
Connect the UPS Input and UPS Output Cables	35
Interconnect the UPS and the Maintenance Bypass Cabinet	37
Connect the Power Cables on the Maintenance Bypass Cabinet with Output Transformer (GVSBPOT100T)	39
Connect the Power Cables on the Maintenance Bypass Cabinet without Transformer (GVSBP100T)	40
Connect the Signal Cables	41
Final Installation	44

Important Safety Instructions — SAVE THESE INSTRUCTIONS

Read these instructions carefully and look at the equipment to become familiar with it before trying to install, operate, service or maintain it. The following safety messages may appear throughout this manual or on the equipment to warn of potential hazards or to call attention to information that clarifies or simplifies a procedure.



The addition of this symbol to a “Danger” or “Warning” safety message indicates that an electrical hazard exists which will result in personal injury if the instructions are not followed.



This is the safety alert symbol. It is used to alert you to potential personal injury hazards. Obey all safety messages with this symbol to avoid possible injury or death.

DANGER

DANGER indicates a hazardous situation which, if not avoided, **will result in death or serious injury.**

Failure to follow these instructions will result in death or serious injury.

WARNING

WARNING indicates a hazardous situation which, if not avoided, **could result in death or serious injury.**

Failure to follow these instructions can result in death, serious injury, or equipment damage.

CAUTION

CAUTION indicates a hazardous situation which, if not avoided, **could result in minor or moderate injury.**

Failure to follow these instructions can result in injury or equipment damage.

NOTICE

NOTICE is used to address practices not related to physical injury. The safety alert symbol shall not be used with this type of safety message.

Failure to follow these instructions can result in equipment damage.

Please Note

Electrical equipment should only be installed, operated, serviced, and maintained by qualified personnel. No responsibility is assumed by Schneider Electric for any consequences arising out of the use of this material.

A qualified person is one who has skills and knowledge related to the construction, installation, and operation of electrical equipment and has received safety training to recognize and avoid the hazards involved.

FCC Statement

NOTE: This equipment has been tested and found to comply with the limits for a Class A digital device, pursuant to Part 15 of the FCC Rules. These limits are designed to provide reasonable protection against harmful interference when the equipment is operated in a commercial environment. This equipment generates, uses, and can radiate radio frequency energy and, if not installed and used in accordance with the instruction manual, may cause harmful interference to radio communications. Operation of this equipment in a residential area is likely to cause harmful interference in which case the user will be required to correct the interference at his own expense.

Any changes or modifications not expressly approved by the party responsible for compliance could void the user's authority to operate the equipment.

Safety Precautions

DANGER

HAZARD OF ELECTRIC SHOCK, EXPLOSION, OR ARC FLASH

Read all instructions in the installation manual before installing or working on this product.

Failure to follow these instructions will result in death or serious injury.

DANGER

HAZARD OF ELECTRIC SHOCK, EXPLOSION, OR ARC FLASH

Do not install the product until all construction work has been completed and the installation room has been cleaned.

Failure to follow these instructions will result in death or serious injury.

DANGER

HAZARD OF ELECTRIC SHOCK, EXPLOSION, OR ARC FLASH

The product must be installed according to the specifications and requirements as defined by Schneider Electric. It concerns in particular the external and internal protections (upstream breakers, battery breakers, cabling, etc.) and environmental requirements. No responsibility is assumed by Schneider Electric if these requirements are not respected.

Failure to follow these instructions will result in death or serious injury.

DANGER

HAZARD OF ELECTRIC SHOCK, EXPLOSION, OR ARC FLASH

The UPS system must be installed according to local and national regulations. Install the UPS according to:

- IEC 60364 (including 60364-4-41- protection against electric shock, 60364-4-42 - protection against thermal effect, and 60364-4-43 - protection against overcurrent), or
- NEC NFPA 70, or
- Canadian Electrical Code (C22.1, Part 1)

depending on which one of the standards apply in your local area.

Failure to follow these instructions will result in death or serious injury.

⚠ ⚠ DANGER

HAZARD OF ELECTRIC SHOCK, EXPLOSION, OR ARC FLASH

- Install the product in a temperature controlled indoor environment free of conductive contaminants and humidity.
- Install the product on a non-flammable, level and solid surface (e.g. concrete) that can support the weight of the system.

Failure to follow these instructions will result in death or serious injury.

⚠ ⚠ DANGER

HAZARD OF ELECTRIC SHOCK, EXPLOSION, OR ARC FLASH

The product is not designed for and must therefore not be installed in the following unusual operating environments:

- Damaging fumes
- Explosive mixtures of dust or gases, corrosive gases, or conductive or radiant heat from other sources
- Moisture, abrasive dust, steam or in an excessively damp environment
- Fungus, insects, vermin
- Salt-laden air or contaminated cooling refrigerant
- Pollution degree higher than 2 according to IEC 60664-1
- Exposure to abnormal vibrations, shocks, and tilting
- Exposure to direct sunlight, heat sources, or strong electromagnetic fields

Failure to follow these instructions will result in death or serious injury.

⚠ ⚠ DANGER

HAZARD OF ELECTRIC SHOCK, EXPLOSION, OR ARC FLASH

Do not drill or cut holes for cables or conduits with the gland plates installed and do not drill or cut holes in close proximity to the UPS.

Failure to follow these instructions will result in death or serious injury.

⚠ ⚠ WARNING

HAZARD OF ARC FLASH

Do not make mechanical changes to the product (including removal of cabinet parts or drilling/cutting of holes) that are not described in the installation manual.

Failure to follow these instructions can result in death, serious injury, or equipment damage.

NOTICE

RISK OF OVERHEATING

Respect the space requirements around the product and do not cover the ventilation openings when the product is in operation.

Failure to follow these instructions can result in equipment damage.

Additional Safety Precautions After Installation

DANGER

HAZARD OF ELECTRIC SHOCK, EXPLOSION, OR ARC FLASH

Do not install the UPS system until all construction work has been completed and the installation room has been cleaned. If additional construction work is needed in the installation room after this product has been installed, turn off the product and cover the product with the protective packaging bag the product was delivered in.

Failure to follow these instructions will result in death or serious injury.

Electrical Safety

This manual contains important safety instructions that should be followed during the installation and maintenance of the product.

DANGER

HAZARD OF ELECTRIC SHOCK, EXPLOSION, OR ARC FLASH

- Electrical equipment must be installed, operated, serviced, and maintained only by qualified personnel.
- Apply appropriate personal protective equipment (PPE) and follow safe electrical work practices.
- Disconnection devices for AC and DC must be provided by others, be readily accessible, and the function of the disconnect device marked for its function.
- Turn off all power supplying the product before working on or inside the equipment.
- Before working on the product, check for hazardous voltage between all terminals including the protective earth.
- The product contains an internal energy source. Hazardous voltage can be present even when disconnected from the mains supply. Before installing or servicing the product, ensure that the product is OFF and that utility/mains and batteries are disconnected. Wait five minutes before opening the product to allow the capacitors to discharge.
- The product must be properly earthed/grounded and due to a high leakage current, the earthing/grounding conductor must be connected first.

Failure to follow these instructions will result in death or serious injury.

When the input is connected through external isolators that, when opened, isolate the neutral or when the automatic backfeed isolation is provided external to the equipment or is connected to an IT power distribution system, a label must be fitted at the input terminals, and on all primary power isolators installed remotely from the installation area and on external access points between such isolators and the product, by the user, displaying the following text (or equivalent in a language which is acceptable in the country in which the product is installed):

DANGER

HAZARD OF ELECTRIC SHOCK, EXPLOSION, OR ARC FLASH

Risk of voltage backfeed. Before working on this circuit: Isolate the product and check for hazardous voltage between all terminals including the protective earth.

Failure to follow these instructions will result in death or serious injury.

Specifications

Specifications for Maintenance Bypass Cabinet with Output Transformer (GVSBPOT100T)

UPS rating	20 kW	30 kW	40 kW	50 kW	60 kW	80 kW	100 kW
Input voltage (V)	480						
Input connections	3-wire (L1, L2, L3, PE)						
Nominal input current (A)	25	37	50	62	74	99	124
Maximum input current (A)	30	45	60	74	89	119	149
Output connections	4-wire (L1, L2, L3, N, PE)						
Output voltage (V)	208						
Nominal output current (A)	56	83	111	139	167	222	278
Output frequency (Hz)	60						
Circuit breaker interrupting ratings (kA)	65 at 480 V (for UIB/MBB/UOB)						

Trip Settings

NOTE: Set the breaker settings per UPS system kW rating as listed in the table below. Changing the settings to other than the listed settings will change the 125% and 150% overload operation, and will impact system performance.

UPS rating	20 kW		30 kW		40 kW		50 kW	
	UIB	MBB/UOB	UIB	MBB/UOB	UIB	MBB/UOB	UIB	MBB/UOB
Breaker type	JJF36250-CU31X	HJF36150-CU31X	JJF36250-CU31X	HJF36150-CU31X	JJF36250-CU31X	HJF36150-CU31X	JJF36250-CU31X	HJF36150-CU31X
I _r setting	70	50	70	50	80	60	80	70
Tr at 6 I _r setting	0.5	1	0.5	2	0.5	2	0.5	2
I _{li} (x I _n) setting	5	8	5	8	6	8	6	8

UPS rating	60 kW		80 kW		100 kW	
	UIB	MBB/UOB	UIB	MBB/UOB	UIB	MBB/UOB
Breaker type	JJF36250CU31-X	HJF36150C-U31X	JJF36250CU31-X	HJF36150C-U31X	JJF36250CU31-X	HJF36150C-U31X
I _r setting	100	90	150	125	175	150
Tr at 6 I _r setting	0.5	4	0.5	2	0.5	2
I _{li} (x I _n) setting	6	8	6	8	6	8

Recommended Upstream Protection

UPS rating	20 kW	30 kW	40 kW	50 kW	60 kW	80 kW	100 kW
	Input	Input	Input	Input	Input	Input	Input
Breaker type	HJF36100-U31X	HJF36100-U31X	HJF36100-U31X	HJF36150-U31X	HJF36150-U31X	JJL36250C-U31X	JJL36250-U31X
Ir setting	60	80	100	100	125	175	200
Tr at 6 Ir setting	0.5	0.5	0.5	0.5	0.5	0.5	0.5
li (x In) setting	1.5	1.5	1.5	1.5	1.5	1.5	1.5

Recommended Cables Sizes

⚠ DANGER

HAZARD OF ELECTRIC SHOCK, EXPLOSION, OR ARC FLASH

All wiring must comply with all applicable national and/or electrical codes. The maximum allowable cable size is 300 kcmil.

Failure to follow these instructions will result in death or serious injury.

NOTE: Overcurrent protection and cable lugs are to be provided by others.

Cable sizes in this manual are based on Table 310.15 (B)(16) of the National Electrical Code (NEC) with the following assertions:

- 90 °C (194 °F) conductors (75 °C (167 °F) termination)
- An ambient temperature of 30 °C (86 °F)
- Use of copper or aluminum conductors

If the ambient temperature is greater than 30 °C (86 °F), larger conductors are to be selected in accordance with the correction factors of the NEC.

Equipment grounding conductors/Protective Earth (PE in this manual) are sized in accordance with NEC Article 250.122 and Table 250.122.

NOTE: Cable sizes are based on 100% rated circuit breakers for UIB, UOB, MBB.

NOTE: Aluminum cables are not supported for 100 kW.

NOTE: Neutral conductor is sized to handle 1.73 times phase current in case of high harmonic content from non-linear loads. If few or no harmonic currents are expected, neutral conductor can be sized as phase conductor.

UPS rating	20 kW		30 kW		40 kW		50 kW	
	Copper	Aluminum	Copper	Aluminum	Copper	Aluminum	Copper	Aluminum
Input phases (AWG/kcmil)	8	6	6	4	4	2	3	1
Input PE (AWG/kcmil)	10	8	8	6	8	6	6	4
Output phases (AWG/kcmil)	6	4	4	2	2	1/0	1/0	3/0
Output PE (AWG/kcmil)	10	8	10	8	8	6	8	6
Neutral (AWG/kcmil)	3	1	1	3/0	3/0	2 x 1	2 x 1	2 x 2/0

UPS rating	60 kW		80 kW		100 kW	
	Copper	Aluminum	Copper	Aluminum	Copper	Aluminum
Input phases (AWG/kcmil)	3	1	1/0	3/0	2/0	

UPS rating	60 kW		80 kW		100 kW	
	Copper	Aluminum	Copper	Aluminum	Copper	Aluminum
Input PE (AWG/kcmil)	8	6	6	4	6	
Output phases (AWG/kcmil)	2/0	4/0	2 x 1	2 x 1/0	2 x 1/0	
Output PE (AWG/kcmil)	6	4	4	2	4	
Neutral (AWG/kcmil)	2 x 1/0	2 x 3/0	2 x 3/0	2 x 250	2 x 250	

Specifications for Maintenance Bypass Cabinet without Transformer (GVSBP100T) 480 V

UPS rating	20 kW	30 kW	40 kW	50 kW	60 kW	80 kW	100 kW
Input voltage (V)	480						
Input connections	4-wire (L1, L2, L3, N, PE) (single mains) 3-wire (L1, L2, L3, PE) (dual mains) ¹						
Nominal input current (A)	25	37	50	62	74	99	124
Maximum input current (A)	30	45	60	74	89	119	149
Bypass voltage (V) ¹	480						
Bypass connection ¹	4-wire (L1, L2, L3, N, PE)						
Nominal bypass current (A) ¹	24	36	49	61	73	97	121
Nominal neutral current (A)	42	62	83	104	125	166	208
Output connections	4-wire (L1, L2, L3, N, PE)						
Output voltage (V)	480						
Nominal output current (A)	24	36	48	60	73	97	121
Output frequency (Hz)	60						
Circuit breaker interrupting ratings (kA)	65 at 480 V (for UIB/SSIB ¹ /MBB/UOB)						

Trip Settings 480 V

NOTE: Set the breaker settings per UPS system kW rating as listed in the table below. Changing the settings to other than the listed settings will change the 125% and 150% overload operation, and will impact system performance.

UPS rating	20 kW		30 kW		40 kW		50 kW	
	UIB	SSIB ¹ / MBB/UOB	UIB	SSIB ¹ / MBB/UOB	UIB	SSIB ¹ / MBB/UOB	UIB	SSIB ¹ / MBB/UOB
Breaker type	JJF36250-CU31X	HJF36150-CU31X	JJF36250-CU31X	HJF36150-CU31X	JJF36250-CU31X	HJF36150-CU31X	JJF36250-CU31X	HJF36150-CU31X
I _r setting	70	50	70	50	80	60	80	70
Tr at 6 I _r setting	0.5	1	0.5	2	0.5	2	0.5	2
I _l (x I _n) setting	5	8	5	8	6	8	6	8

UPS rating	60 kW		80 kW		100 kW	
	UIB	SSIB ¹ /MBB/ UOB	UIB	SSIB ¹ /MBB/ UOB	UIB	SSIB ¹ /MBB/ UOB
Breaker type	JJF36250CU31-X	HJF36150C-U31X	JJF36250CU31-X	HJF36150C-U31X	JJF36250CU31-X	HJF36150C-U31X
I _r setting	100	90	150	125	175	150
Tr at 6 I _r setting	0.5	4	0.5	2	0.5	2
I _l (x I _n) setting	6	8	6	8	6	8

1. Only applicable with optional kit for dual mains (GVSOPT031) installed.

Recommended Upstream Protection 480 V

Refer to the recommended upstream protection in the UPS installation manual.

Recommended Cables Sizes 480 V

⚠ DANGER

HAZARD OF ELECTRIC SHOCK, EXPLOSION, OR ARC FLASH

All wiring must comply with all applicable national and/or electrical codes. The maximum allowable cable size is 300 kcmil.

Failure to follow these instructions will result in death or serious injury.

NOTE: Overcurrent protection and cable lugs are to be provided by others. Cable sizes in this manual are based on Table 310.15 (B)(16) of the National Electrical Code (NEC) with the following assertions:

- 90 °C (194 °F) conductors (75 °C (167 °F) termination)
- An ambient temperature of 30 °C (86 °F)
- Use of copper or aluminum conductors

If the ambient temperature is greater than 30 °C (86 °F), larger conductors are to be selected in accordance with the correction factors of the NEC.

Equipment grounding conductors/Protective Earth (PE in this manual) are sized in accordance with NEC Article 250.122 and Table 250.122.

NOTE: Cable sizes are based on 100% rated circuit breakers for UIB, UOB, MBB, SSIB.

NOTE: Aluminum cables are not supported for 100 kW.

NOTE: Neutral conductor is sized to handle 1.73 times phase current in case of high harmonic content from non-linear loads. If few or no harmonic currents are expected, neutral conductor can be sized as phase conductor.

UPS rating	20 kW		30 kW		40 kW		50 kW	
	Copper	Aluminum	Copper	Aluminum	Copper	Aluminum	Copper	Aluminum
Input phases (AWG/kcmil)	8	6	6	4	4	2	3	1
Input PE (AWG/kcmil)	10	8	8	6	8	6	6	4
Bypass/output phases (AWG/kcmil)	10	8	8	6	6	4	4	2
Bypass PE/output PE (AWG/kcmil)	10	8	10	8	8	6	8	6
Neutral (AWG/kcmil)	6	4	4	2	2	1/0	1/0	3/0

UPS rating	60 kW		80 kW		100 kW	
	Copper	Aluminum	Copper	Aluminum	Copper	Aluminum
Input phases (AWG/kcmil)	3	1	1/0	3/0	2/0	
Input PE (AWG/kcmil)	8	6	6	4	6	
Bypass/output phases (AWG/kcmil)	3	1	2	1/0	1	
Bypass PE/output PE (AWG/kcmil)	8	6	6	4	6	
Neutral (AWG/kcmil)	1	2/0	2/0	4/0	2 x 2	

Specifications for Maintenance Bypass Cabinet without Transformer (GVSBP100T) 208 V

UPS rating	10 kW	15 kW	20 kW	25 kW	30 kW	40 kW	50 kW
Input voltage (V)	208						
Input connections	4-wire (L1, L2, L3, N, PE) (single mains) 3-wire (L1, L2, L3, PE) (dual mains) ²						
Nominal input current (A)	30	45	60	75	90	119	149
Maximum input current (A)	36	54	72	90	107	143	179
Bypass voltage (V) ²	208						
Bypass connection ²	4-wire (L1, L2, L3, N, PE)						
Nominal bypass current (A) ²	28	42	56	70	84	112	140
Nominal neutral current (A)	48	72	96	120	144	192	240
Output connections	4-wire (L1, L2, L3, N, PE)						
Output voltage (V)	208						
Nominal output current (A)	28	42	56	70	83	111	139
Output frequency (Hz)	60						
Circuit breaker interrupting ratings (kA)	65 at 208 V (for UIB/SSIB ² /MBB/UOB)						

Trip Settings 208 V

NOTE: Set the breaker settings per UPS system kW rating as listed in the table below. Changing the settings to other than the listed settings will change the 125% and 150% overload operation, and will impact system performance.

UPS rating	10 kW		15 kW		20 kW		25 kW	
	UIB	SSIB ² /MBB/UOB	UIB	SSIB ² /MBB/UOB	UIB	SSIB ² /MBB/UOB	UIB	SSIB ² /MBB/UOB
Breaker type	JJF36250-CU31X	HJF36150-CU31X	JJF36250-CU31X	HJF36150-CU31X	JJF36250-CU31X	HJF36150-CU31X	JJF36250-CU31X	HJF36150-CU31X
I _r setting	70	50	80	60	100	80	120	90
Tr at 6 I _r setting	0.5	1	0.5	1	0.5	1	0.5	1
I _i (x I _n) setting	5	8	5	8	5	8	5	8

UPS rating	30 kW		40 kW		50 kW	
	UIB	SSIB ² /MBB/UOB	UIB	SSIB ² /MBB/UOB	UIB	SSIB ² /MBB/UOB
Breaker type	JJF36250CU31-X	HJF36150C-U31X	JJF36250CU31-X	HJF36150C-U31X	JJF36250CU31-X	HJF36150C-U31X
I _r setting	150	90	200	125	250	150
Tr at 6 I _r setting	0.5	2	0.5	2	0.5	2
I _i (x I _n) setting	5	8	6	8	6	8

2. Only applicable with optional kit for dual mains (GVSOPT031) installed.

Recommended Upstream Protection 208 V

Refer to the recommended upstream protection in the UPS installation manual.

Recommended Cables Sizes 208 V

⚠ DANGER

HAZARD OF ELECTRIC SHOCK, EXPLOSION, OR ARC FLASH

All wiring must comply with all applicable national and/or electrical codes. The maximum allowable cable size is 300 kcmil.

Failure to follow these instructions will result in death or serious injury.

NOTE: Overcurrent protection and cable lugs are to be provided by others. Cable sizes in this manual are based on Table 310.15 (B)(16) of the National Electrical Code (NEC) with the following assertions:

- 90 °C (194 °F) conductors (75 °C (167 °F) termination)
- An ambient temperature of 30 °C (86 °F)
- Use of copper or aluminum conductors

If the ambient temperature is greater than 30 °C (86 °F), larger conductors are to be selected in accordance with the correction factors of the NEC.

Equipment grounding conductors/Protective Earth (PE in this manual) are sized in accordance with NEC Article 250.122 and Table 250.122.

NOTE: Cable sizes are based on 100% rated circuit breakers for UIB, UOB, MBB, SSIB.

NOTE: Aluminum cables are not supported for 40 kW and 50 kW.

NOTE: Neutral conductor is sized to handle 1.73 times phase current in case of high harmonic content from non-linear loads. If few or no harmonic currents are expected, neutral conductor can be sized as phase conductor.

UPS rating	10 kW		15 kW		20 kW		25 kW	
	Copper	Aluminum	Copper	Aluminum	Copper	Aluminum	Copper	Aluminum
Input phases (AWG/kcmil)	8	6	4	2	3	1	2	1/0
Input PE (AWG/kcmil)	10	8	8	6	8	6	6	4
Bypass/output phases (AWG/kcmil)	8	6	6	4	4	2	3	1
Bypass PE/output PE (AWG/kcmil)	10	8	10	8	8	6	8	6
Neutral (AWG/kcmil)	6	4	3	1	1	2/0	2/0	4/0

UPS rating	30 kW		40 kW		50 kW	
	Copper	Aluminum	Copper	Aluminum	Copper	Aluminum
Input phases (AWG/kcmil)	1/0	3/0	3/0		4/0	
Input PE (AWG/kcmil)	6	4	6		4	
Bypass/output phases (AWG/kcmil)	2	1/0	1/0		3/0	
Bypass PE/output PE (AWG/kcmil)	6	4	6		5	
Neutral (AWG/kcmil)	3/0	2 x 1	2 x 1/0		2 x 2/0	

Recommended Bolt and Lug Sizes

NOTICE

RISK OF EQUIPMENT DAMAGE

Use only UL approved compression cable lugs.

Failure to follow these instructions can result in equipment damage.

Copper — One Hole Cable Lugs

Cable size	Bolt size	Cable lug type	Crimping tool	Die
10 AWG	M8 x 35 mm	LCA10-56-L	NA	NA
8 AWG	M8 x 35 mm	LCA8-56-L	CT-720	CD-720-1 Red P21
6 AWG	M8 x 35 mm	LCA6-56-L	CT-720	CD-720-1 Blue P24
4 AWG	M8 x 35 mm	LCA4-56-L	CT-720	CD-720-1 Gray P29
3 AWG	M8 x 35 mm	LCA4-56-L	CT-720	CD-720-1 Gray P29
2 AWG	M8 x 35 mm	LCA2-56-Q	CT-720	CD-720-1 Brown P33
1 AWG	M8 x 35 mm	LCA1-56-E	CT-720	CD-720-2 Green P37
1/0 AWG	M8 x 35 mm	LCA1/0-56-X	CT-720	CD-720-2 Pink P42
2/0 AWG	M8 x 35 mm	LCA2/0-56-X	CT-720	CD-720-2 Black P45
3/0 AWG	M8 x 35 mm	LCA3/0-56-X	CT-720	CD-720-2 Orange P50
4/0 AWG	M8 x 35 mm	LCA4/0-56-X	CT-720	CD-720-3 Purple P54
250 kcmil	M8 x 35 mm	LCA250-56-X	CT-720	CD-720-3 Yellow P62
300 kcmil	M8 x 35 mm	LCA300-56-X	CT-720	CD-720-4 White P66

Aluminum — One Hole Cable Lugs

Cable size	Bolt size	Cable lug type	Crimping tool	Die
6 AWG	M8 x 35 mm	LAA6-56-x	CT-720	CD-720-1 Gray P29
4 AWG	M8 x 35 mm	LAA4-56-x	CT-720	CD-720-2 Green P37
2 AWG	M8 x 35 mm	LAA2-56-x	CT-720	CD-720-2 Pink P42
1 AWG	M8 x 35 mm	LAA1-56-X	CT-720	CD-720-2 Gold P45
1/0 AWG	M8 x 35 mm	LAA1/0-56-5	CT-720	CD-720-2 Tan P50
2/0 AWG	M8 x 35 mm	LAA2/0-38-5	CT-720	CD-720-3 Olive P54
3/0 AWG	M8 x 35 mm	LAA3/0-38-5	CT-720	CD-720-3 Ruby P60
4/0 AWG	M8 x 35 mm	LAA4/0-38-5	CT-720	CD-720-4 White P66
250 kcmil	M8 x 35 mm	LAA250-38-5	CT-720	CD-720-5 Red P71
300 kcmil	M8 x 35 mm	LAA300-38-2	CT-720	CD-720-6 Blue P76

Copper — Two Hole Cable Lugs

Cable size	Bolt size	Cable lug type ³	Crimping tool	Die
6 AWG	M8 x 35 mm	LCC6-12-L	CT-930	CD-920-6 Blue P24
4 AWG	M8 x 35 mm	LCC4-12-L	CT-930	CD-920-4 Gray P29
3 AWG	M8 x 35 mm			
2 AWG	M8 x 35 mm	LCC2-12-Q	CT-930	CD-920-2 Brown P33
1 AWG	M8 x 35 mm	LCC1-12-E	CT-930	CD-920-1 Green P37

3. Use oversized M8 flat washer.

Copper — Two Hole Cable Lugs (Continued)

Cable size	Bolt size	Cable lug type ⁴	Crimping tool	Die
1/0 AWG	M8 x 35 mm	LCC1/0-12-X	CT-930	CD-920-1/0 Pink P42
2/0 AWG	M8 x 35 mm	LCC2/0-12-X	CT-930	CD-920-2/0 Black P45
3/0 AWG	M8 x 35 mm	LCC3/0-12-X	CT-930	CD-920-3/0 Orange P50
4/0 AWG	M8 x 35 mm	LCC4/0-12-X	CT-930	CD-920-4/0 Purple P54
250 kcmil	M8 x 35 mm	LCC250-12-X	CT-930	CD-920-250 Yellow P62
300 kcmil	M8 x 35 mm	LCC300-12-X	CT-930	CD-920-300 White P66

Aluminum — Two Hole Cable Lugs

Cable size	Bolt size	Cable lug type ⁴	Crimping tool	Die
2/0 AWG	M8 x 35 mm	LAB2/0-12-5	CT-720	CD-720-3 Olive P54
3/0 AWG	M8 x 35 mm	LAB3/0-12-5	CT-720	CD-720-3 Ruby P60
4/0 AWG	M8 x 35 mm	LAB4/0-12-5R	CT-720	CD-720-4 White P66
250 kcmil	M8 x 35 mm	LAB250-12-5	CT-720	CD-720-5 Red P71
300 kcmil	M8 x 35 mm	LAB300-12-2	CT-720	CD-720-6 Blue P76

Torque Specifications

Bolt size	Torque
M4	1.7 Nm (1.25 lb-ft / 15 lb-in)
M5	2.2 Nm (1.62 lb-ft / 19.5 lb-in)
M6	5 Nm (3.69 lb-ft / 44.3 lb-in)
M8	17.5 Nm (12.91 lb-ft / 154.9 lb-in)
M10	30 Nm (22 lb-ft / 194.7 lb-in)

Weights and Dimensions

Commercial reference	Weight kg (lbs)	Height mm (in)	Width mm (in)	Depth mm (in)
GVSBPOT100T	921 (2030.45)	1970 (77.56)	600 (23.62)	847 (33.35)
GVSBP100T	406 (895.07)	1970 (77.56)	600 (23.62)	847 (33.35)

4. Use oversized M8 flat washer.

Clearance

NOTE: Clearance dimensions are published for airflow and service access only. Consult with the local safety codes and standards for additional requirements in your local area.

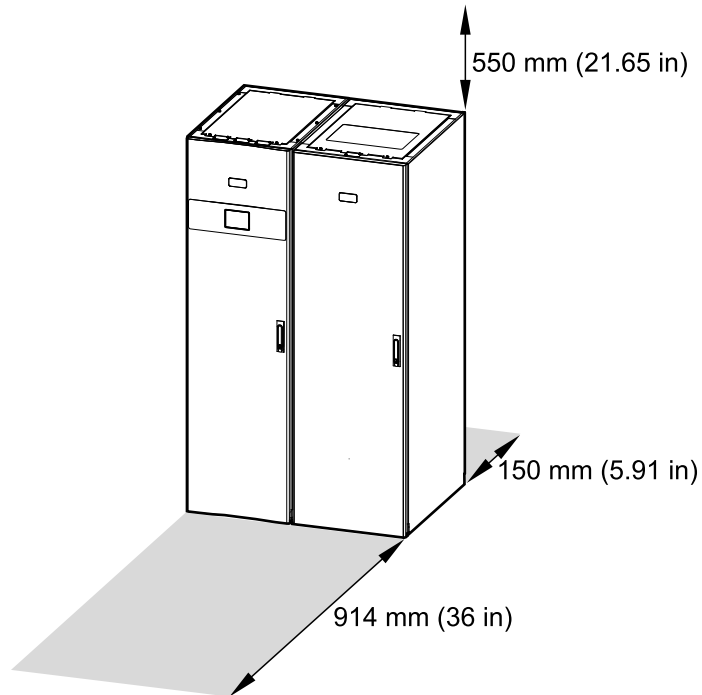

Environment

	Operating	Storage
Temperature	0 °C to 40 °C (32 °F to 104 °F)	-25 °C to 55 °C (-13 °F to 131 °F)
Relative humidity	0 - 95% non-condensing	0-95% non-condensing
Elevation	Designed for operation in 0-3000 m (0-10000 feet) elevation. Power derating required from 1000-3000 m (3300-10000 feet): Up to 1000 m (3300 feet): 1.000 Up to 1500 m (5000 feet): 0.975 Up to 2000 m (6600 feet): 0.950 Up to 2500 m (8300 feet): 0.925 Up to 3000 m (10000 feet): 0.900	
Protection class	IP20	
Color	RAL 9003, gloss level 85%	

System Overview

UIB	Unit input breaker
SSIB	Static switch input breaker
MBB	Maintenance bypass breaker
IMB	Internal maintenance breaker
UOB	Unit output breaker

NOTE: The internal maintenance breaker IMB* in the UPS cannot be used in a system with a maintenance bypass cabinet and must be padlocked in the open position.

UPS System with Maintenance Bypass Cabinet with Output Transformer (GVSBPOT100T) – Single Mains

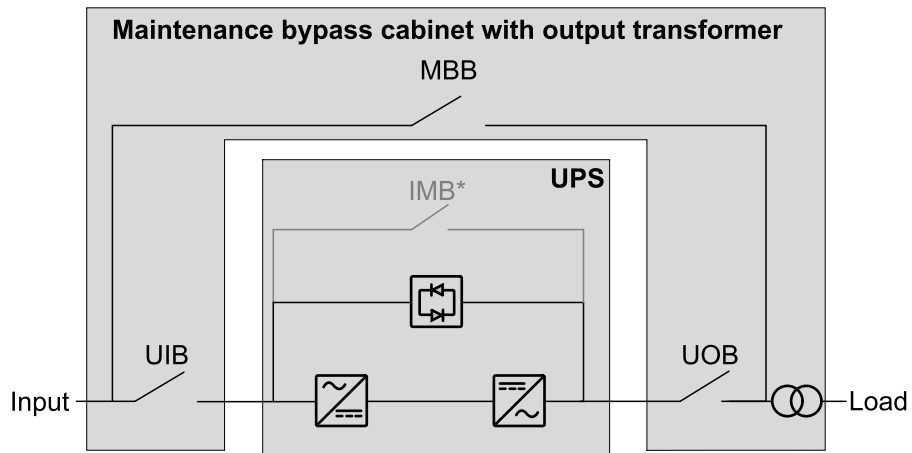

UPS System with Maintenance Bypass Cabinet without Transformer (GVSBP100T) – Single Mains

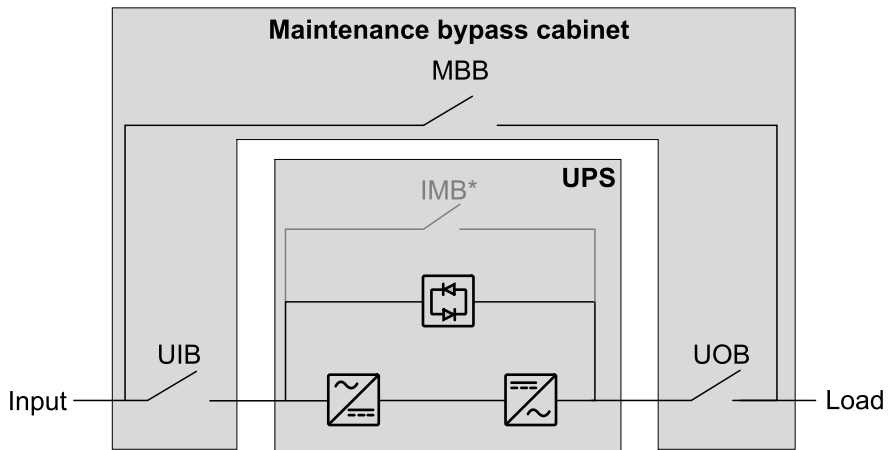

UPS System with Maintenance Bypass Cabinet without Transformer (GVSBP100T) – Dual Mains

NOTE: Available for maintenance bypass cabinet without transformer (GVSBP100T) with optional kit for dual mains (GVSOPT031) installed.

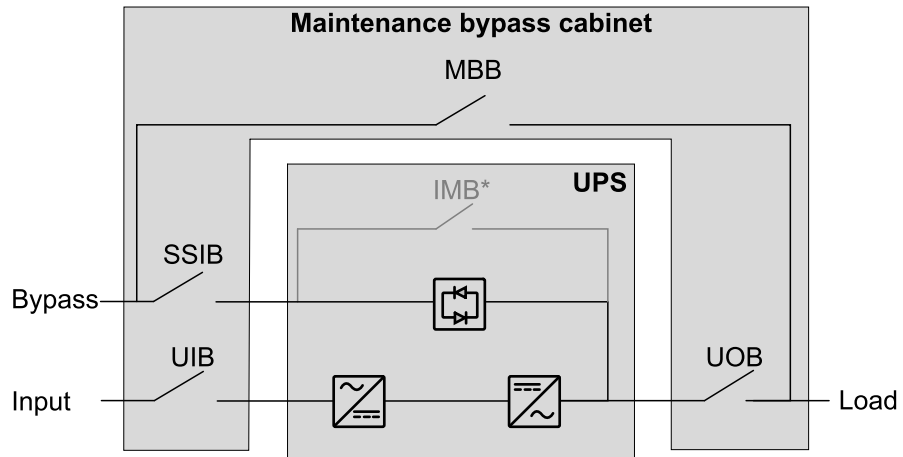

Installation Procedure for Maintenance Bypass Cabinet with Output Transformer (GVSBPOT100T)

Top Entry Installation – Single Mains

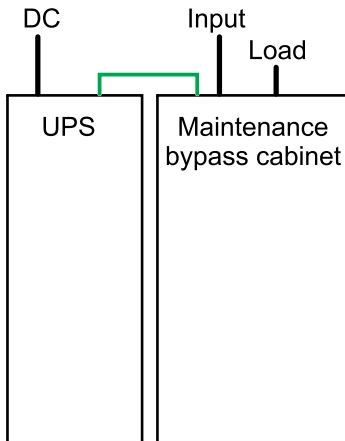

Bottom Entry Installation – Single Mains

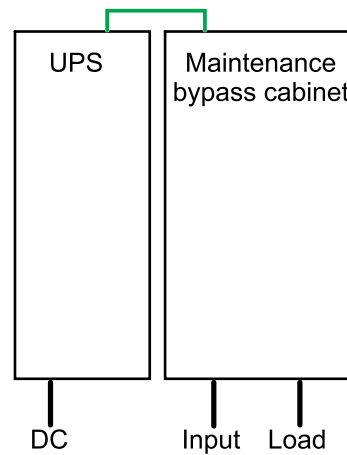

— Signal cable
— Power cable

1. Follow the UPS manual to prepare the UPS for installation.
2. *Unpack the Maintenance Bypass Cabinet, page 25.*
3. *Prepare for Installation, page 28.*
4. *Install the Seismic Anchoring (Option), page 33.*
5. *Connect the UPS Input and UPS Output Cables, page 35.*
6. *Interconnect the UPS and the Maintenance Bypass Cabinet, page 37.*
7. *Connect the Power Cables on the Maintenance Bypass Cabinet with Output Transformer (GVSBPOT100T), page 39.*
8. *Connect the Signal Cables, page 41.*
9. *Final Installation, page 44.*
10. Follow the UPS installation manual to connect the power cables from the maintenance bypass cabinet in the UPS and to complete the rest of the UPS installation.

Installation Procedure for Maintenance Bypass Cabinet without Transformer (GVSBP100T)

Top Entry Installation – Single Mains

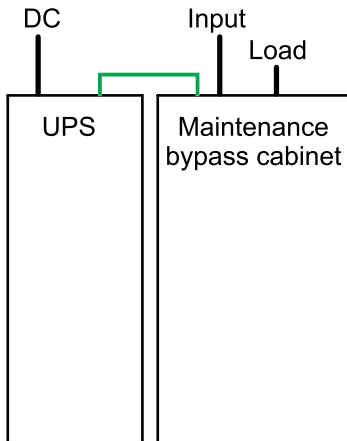

Bottom Entry Installation – Single Mains

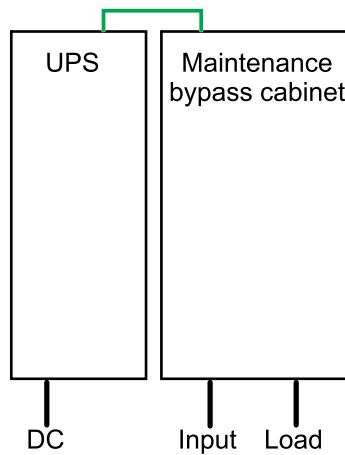

Top Entry Installation – Dual Mains

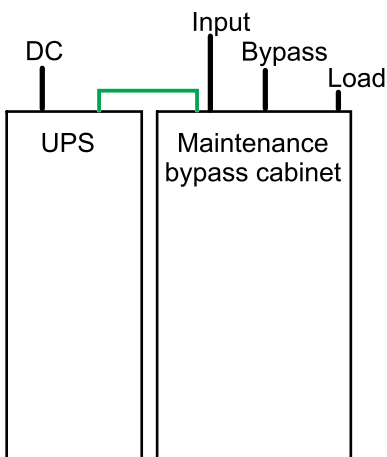

Bottom Entry Installation – Dual Mains

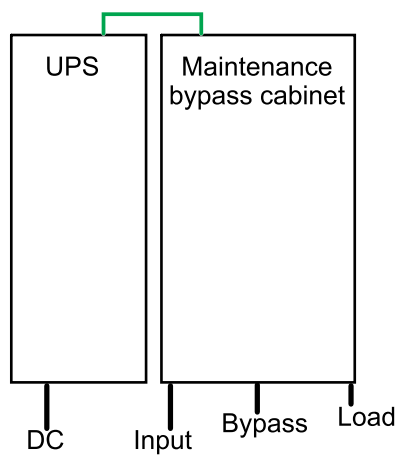

— Signal cable
— Power cable

1. Follow the UPS manual to prepare the UPS for installation.
2. *Unpack the Maintenance Bypass Cabinet, page 25.*
3. *Prepare for Installation, page 28.*
4. **For dual mains system:** *Install the Optional Kit for Dual Mains (GVSOPT031), page 31.*
5. *Install the Seismic Anchoring (Option), page 33.*
6. *Connect the UPS Input and UPS Output Cables, page 35.*
7. *Interconnect the UPS and the Maintenance Bypass Cabinet, page 37.*
8. *Connect the Power Cables on the Maintenance Bypass Cabinet without Transformer (GVSBP100T), page 40.*
9. *Connect the Signal Cables, page 41.*
10. *Final Installation, page 44.*

11. Follow the UPS installation manual to connect the power cables from the maintenance bypass cabinet in the UPS and to complete the rest of the UPS installation.

Receiving

External Inspection

When the shipment arrives, inspect the shipping material for any signs of damage or mishandling. Check tilt and impact indicators. Do not attempt to install the system if a damage is apparent. If any damage is noted, contact Schneider Electric and file a damage claim with the shipping agency within 24 hours.

Compare the components of the shipment with the bill of lading. Report any missing items to the carrier and to Schneider Electric immediately.

Verify that labelled units match the order confirmation.

Unpack the Maintenance Bypass Cabinet

NOTICE

RISK OF EQUIPMENT DAMAGE

Do not unpack the cabinet before the time of installation.

Failure to follow these instructions can result in equipment damage.

NOTICE

RISK OF EQUIPMENT DAMAGE

- Ensure that the floor is level and can support the weight of the jack when it carries the cabinet.
- Be careful not to damage the cabinets when using the jack.

Failure to follow these instructions can result in equipment damage.

1. Remove all the packaging, retrieve the installation kits, and save the protective packaging bag for later use.
2. Remove the front door.
3. Remove the left, right, and middle pallet parts.

Rear View

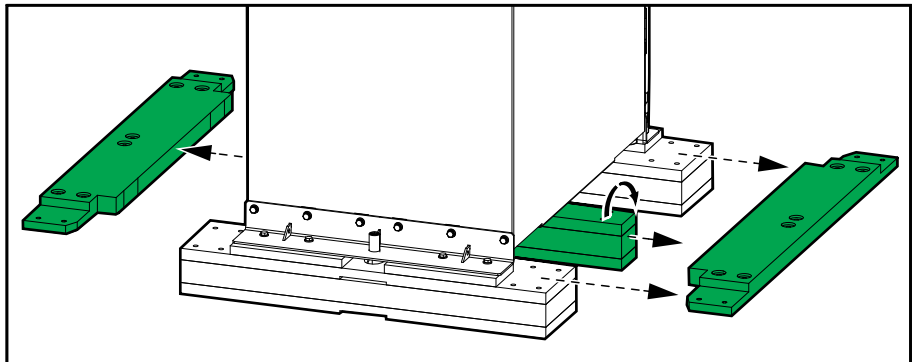

4. Remove the rear pallet part:
 - a. Place the floor protection plate under the pallet on the rear side of the cabinet.
 - b. Remove the bolts from the transportation bracket.
 - c. Place the jack into the transportation bracket hole and use a drilling machine to lift the cabinet up to the max height of the jack.

▲ WARNING

HAZARD OF SERIOUS INJURY

Do not put your hands or feet under the cabinet while removing the pallet.

Failure to follow these instructions can result in death, serious injury, or equipment damage.

Rear View

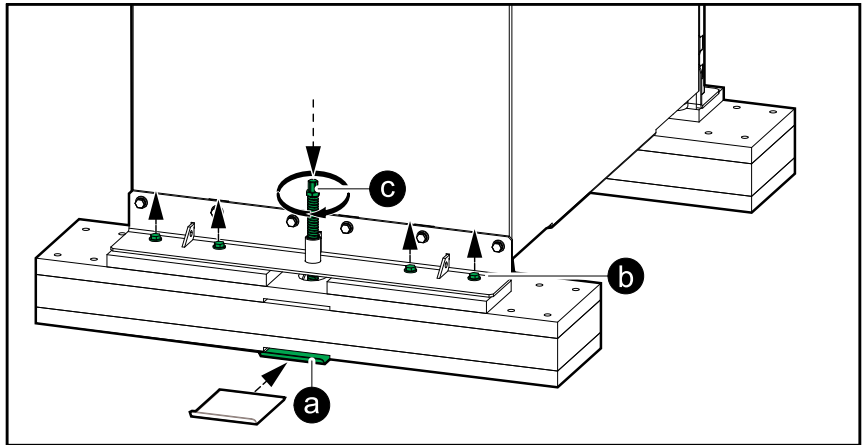

- d. Remove the rear pallet part.

Rear View

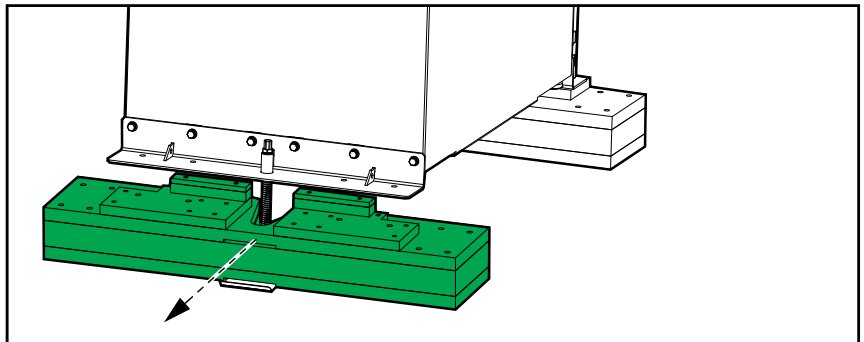

- e. Use the drilling machine on the jack to lower the cabinet down to the floor.

5. Remove the front pallet part:
 - a. Place the floor protection plate under the pallet on the front side of the cabinet.
 - b. Remove the bolts from the transportation bracket.
 - c. Install the small bracket for the jack on the front transportation bracket.
 - d. Place the jack into the transportation bracket hole and use a drilling machine to lift the cabinet up to the max height of the jack.

▲ WARNING

HAZARD OF SERIOUS INJURY

Do not put your hands or feet under the cabinet while removing the pallet.

Failure to follow these instructions can result in death, serious injury, or equipment damage.

Front View

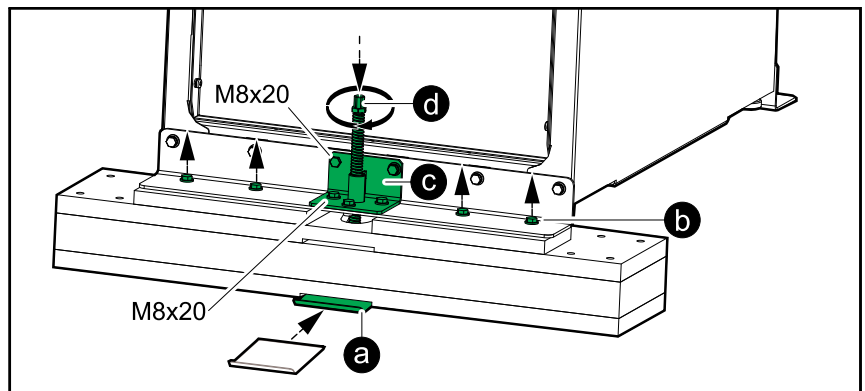

- e. Remove the front pallet part.
 - f. Use the drilling machine on the jack to lower the cabinet down to the floor.
6. Remove the front and rear transportation brackets and the floor protection plate.
 7. Reinstall the front door.

Prepare for Installation

1. Remove the front door.
2. Remove the indicated plates/covers.

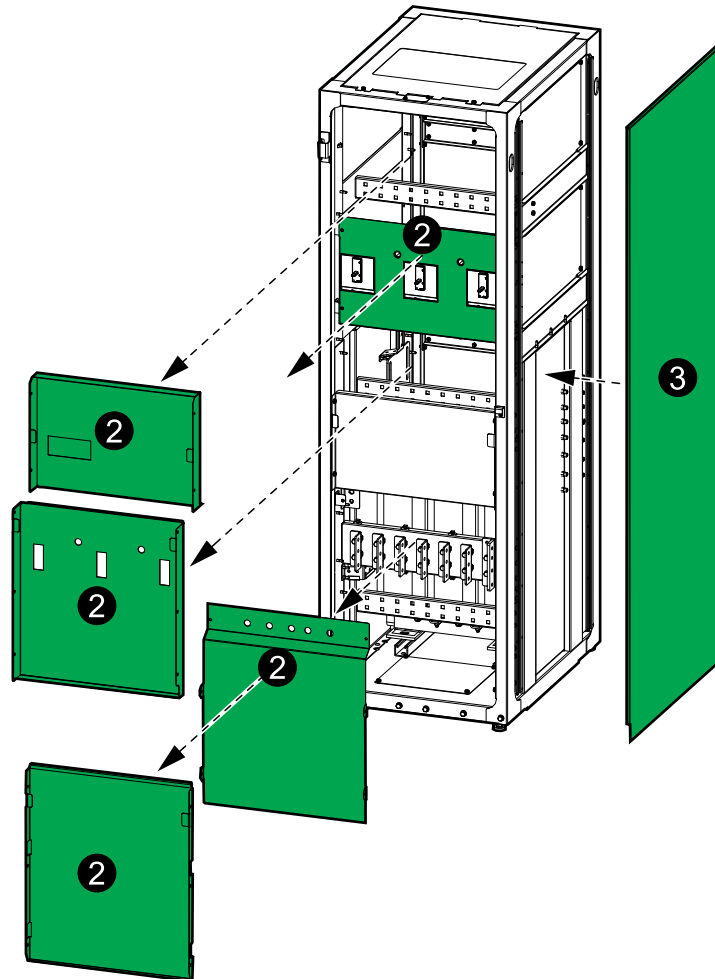

3. Remove the right side panel from the UPS and reinstall the side panel on the right side of the maintenance bypass cabinet.
4. **For top cable entry:** Remove the top plate.
 - a. Remove the gland plate from the top plate.
 - b. Drill or punch holes for input cables, bypass cables (for dual mains systems), and load cables or conduits in the gland plate. Conduits are not provided.

⚡ ⚠ DANGER

HAZARD OF ELECTRIC SHOCK, EXPLOSION, OR ARC FLASH

Do not drill or cut holes for power cables or conduits with the gland plate installed and do not drill or cut holes in close proximity to the cabinet.

Failure to follow these instructions will result in death or serious injury.

- c. Reinstall the gland plate in the top plate.

5. **For top cable entry:** Reinstall the top plate.

- a. Tilt the top plate and slide it onto the maintenance bypass cabinet from the rear. Taps in the rear of the top plate must connect to slots in the maintenance bypass cabinet.

Rear View

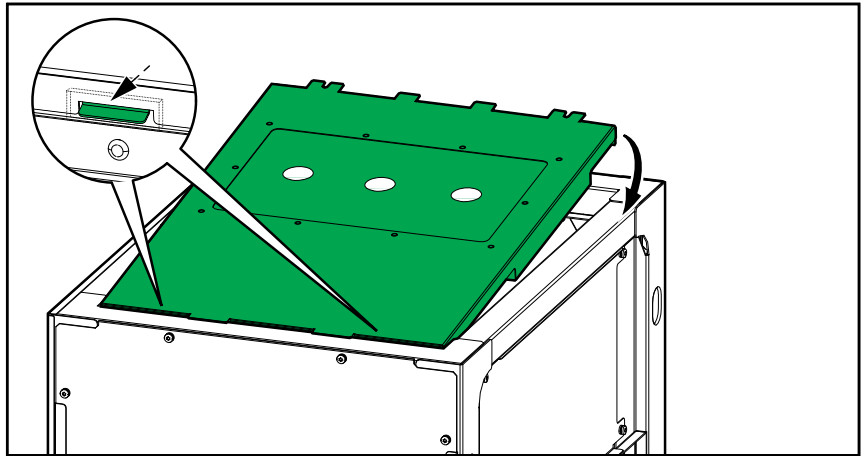

- b. Push the top plate down in the front and reinstall the screws.

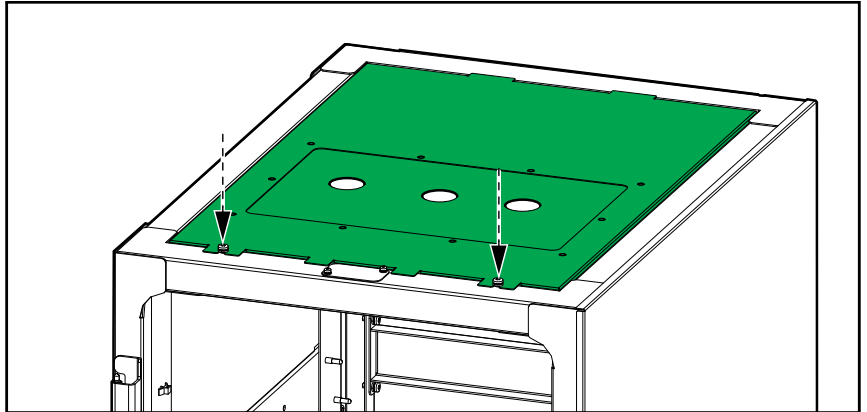

6. For bottom cable entry:

- a. Remove the bottom gland plate.
- b. Drill or punch holes for input cables, bypass cables (for dual mains systems), and load cables or conduits in the gland plate. Conduits are not provided.

⚡ ⚠ DANGER**HAZARD OF ELECTRIC SHOCK, EXPLOSION, OR ARC FLASH**

Do not drill or cut holes for power cables or conduits with the gland plate installed and do not drill or cut holes in close proximity to the cabinet.

Failure to follow these instructions will result in death or serious injury.

- c. Reinstall the bottom gland plate.

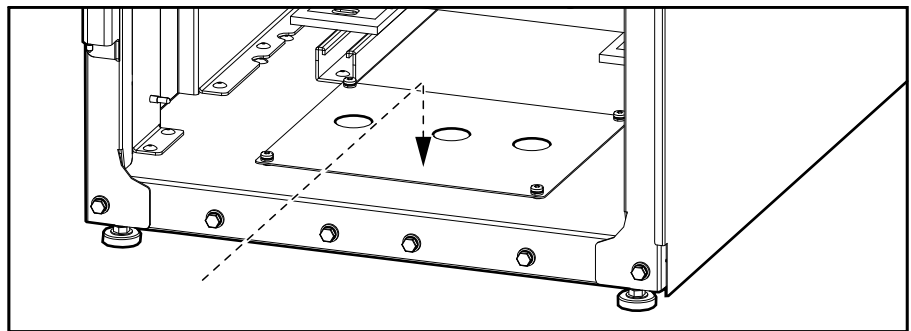

7. Remove the conduit box from the rear of the maintenance bypass cabinet.
8. Remove the rear plate from the conduit box.
9. Install the conduit box on the maintenance bypass cabinet with the provided screws.

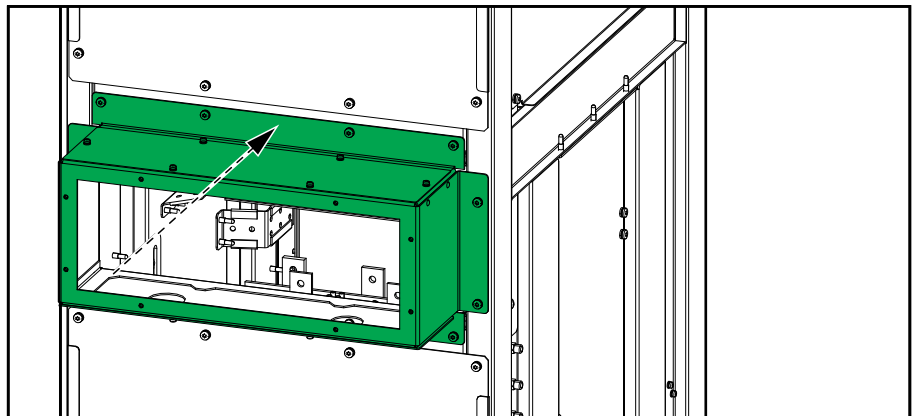
Rear View

Install the Optional Kit for Dual Mains (GVSOPT031)

NOTE: Only applicable for maintenance bypass cabinet without transformer (GVSBP100T).

1. Install the static switch input breaker SSIB.
 - a. Install the static switch input breaker SSIB in the empty position.

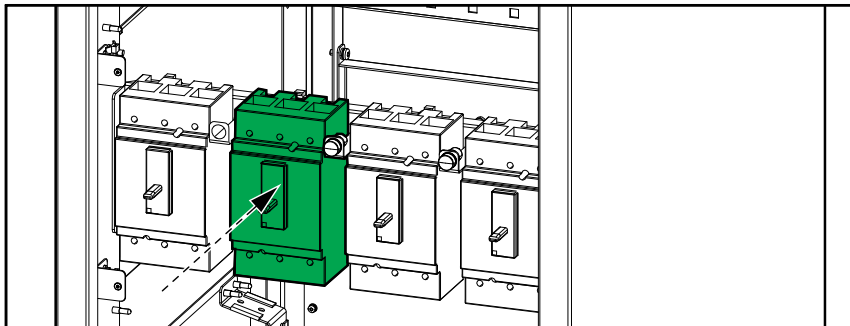

- b. Remove the cover on the SSIB breaker.
 - c. Connect the preinstalled signal cable 0W76868 (SSIB 4 and SSIB 1) to the AUX switch (1 and 4) in the SSIB breaker. The signal cable is located at the empty breaker indicator light bracket.

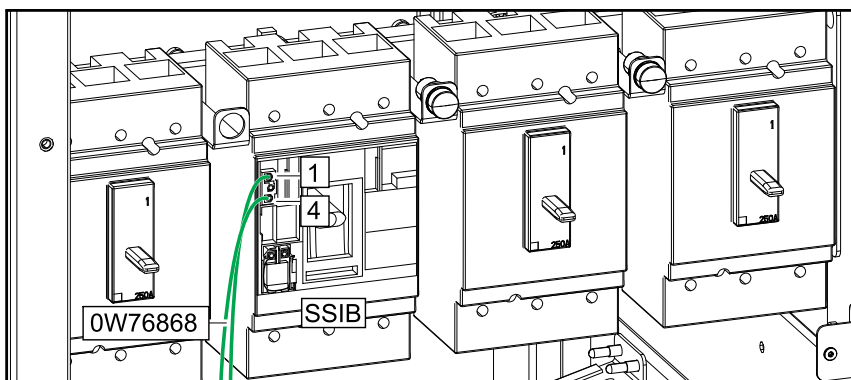

- d. Reinstall the cover on the SSIB breaker.

2. Install the SSIB breaker indicator light.
 - a. Connect the preinstalled signal cable 0W76869 (HSSIB+ and HSSIB-) to the SSIB breaker indicator light (+ and -). The signal cable is located at the empty breaker indicator light bracket.
 - b. Install the SSIB breaker indicator light in the empty breaker indicator light bracket.

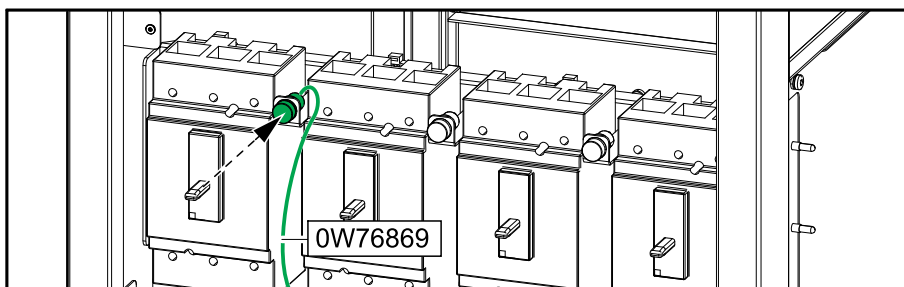

3. Disconnect the MBB breaker power cables from the input busbars and connect to the bypass busbars.

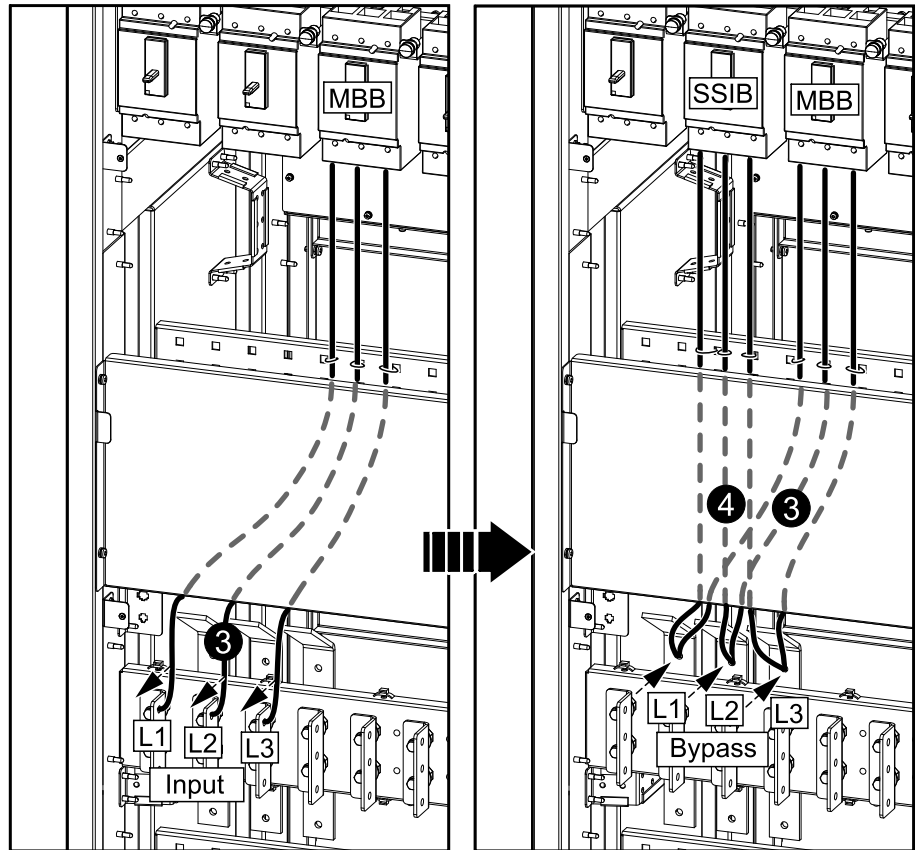

4. Connect the provided power cables from the SSIB breaker to the bypass busbars.
5. Replace label 885-91846 with label 885-91800 and label 885-91257 with label 885-91801 on the upper front plate to show the correct diagrams when the SSIB breaker has been installed.

Install the Seismic Anchoring (Option)

Use the optional seismic kits GVSOPT016 (UPS) and GVSOPT025 (maintenance bypass cabinet).

1. Connect the rear anchoring assemblies with the interconnection plate.

Rear View

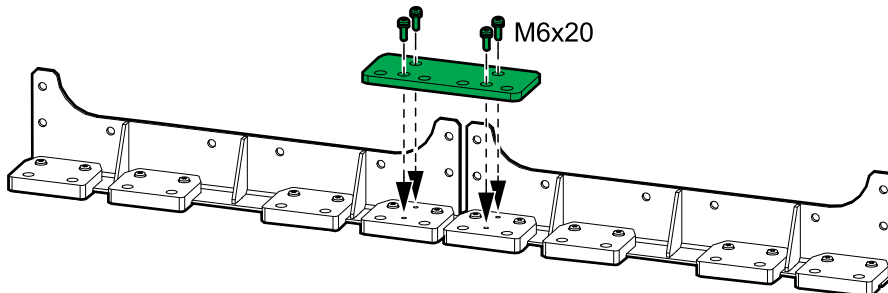

2. Mount the rear anchoring assembly to the floor. Use appropriate hardware for the floor type – the hole diameter in the rear anchors is $\varnothing 13$ mm. Minimum requirement is M12 grade 8.8 hardware.

Rear View

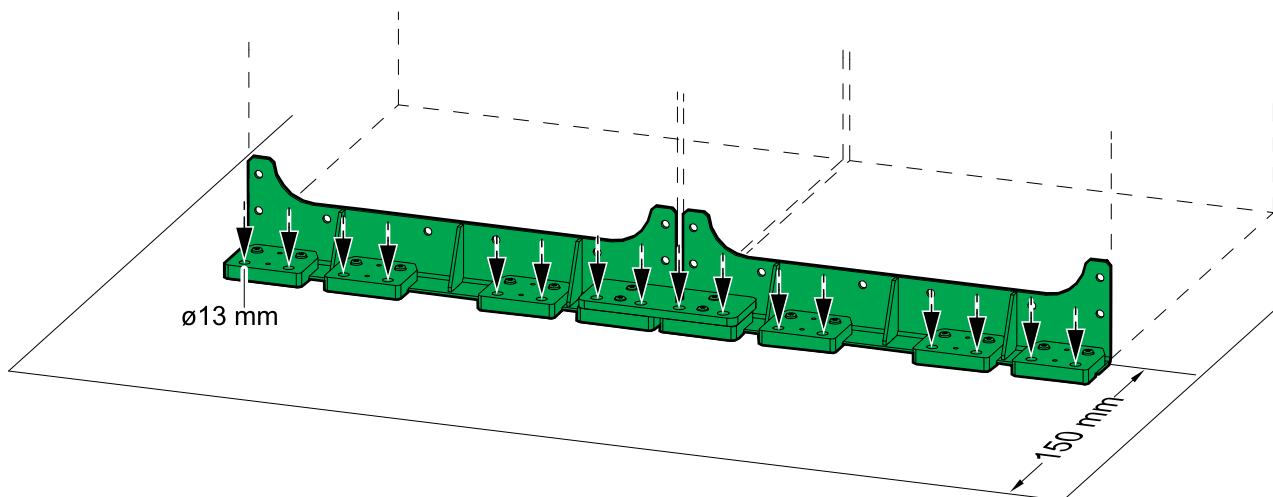

3. Remove all the screws and the interconnection plate.

Rear View

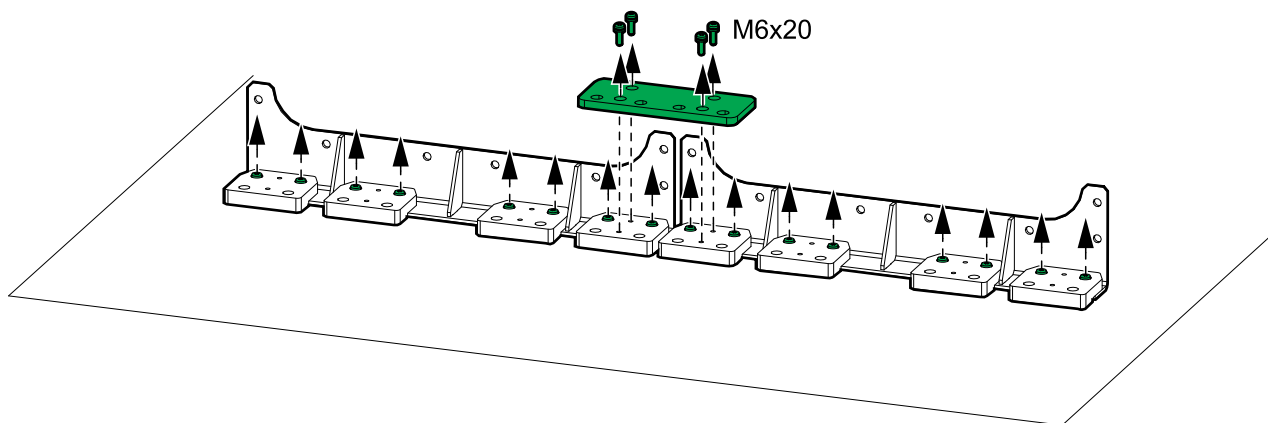

4. Remove the anchoring brackets.

Rear View

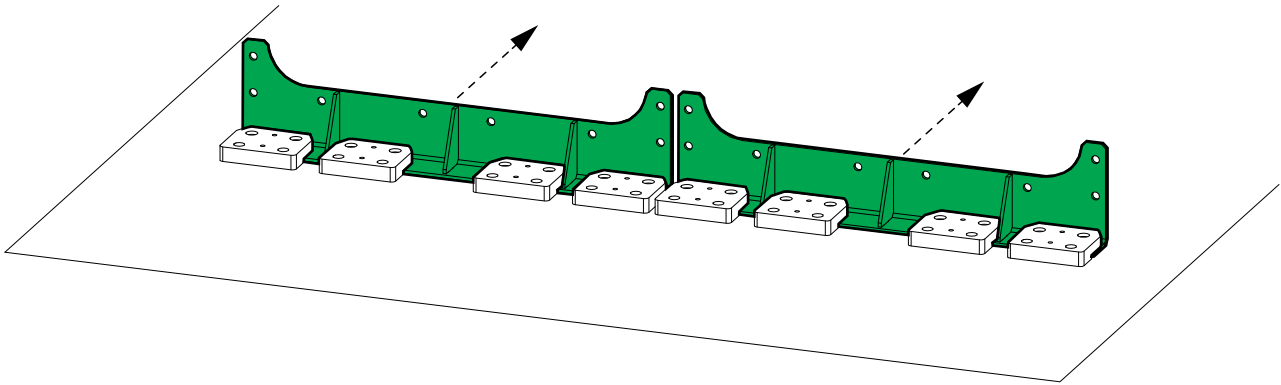

5. Reinstall the interconnection plate.

Rear View

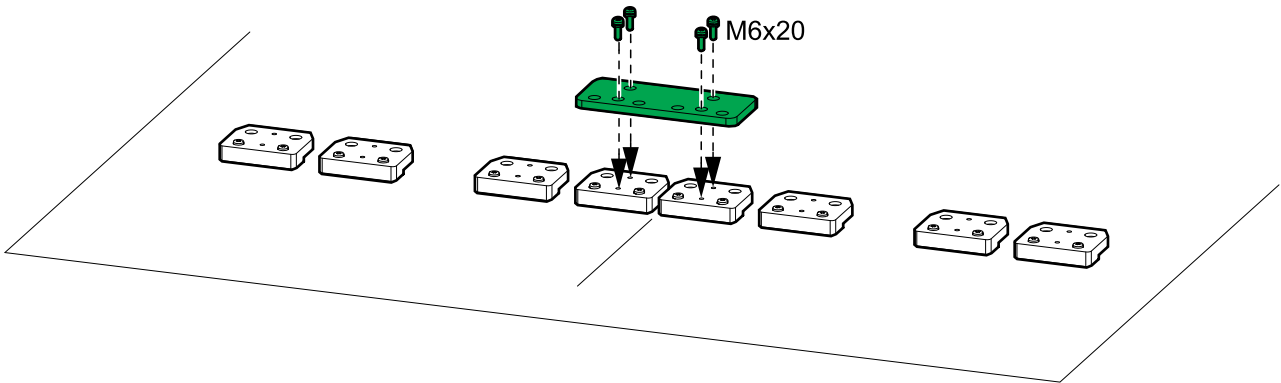

6. Install the rear anchoring brackets on the UPS and the maintenance bypass cabinet with the provided M8 bolts.

Connect the UPS Input and UPS Output Cables

Use installation kit GVSOPT032 for this procedure.

1. Install the provided UPS input and UPS output cables in the conduit box. Route the UPS input and UPS output cables through the side brackets as shown and note that the PE cables are routed to the left.
2. **For maintenance bypass cabinet without transformer (GVSBP100T) with dual mains:** Install the UPS bypass cables (provided in kit GVSOPT031) in the conduit box. Route the UPS bypass cables through the side brackets as shown and note that the PE cable is routed to the left.

Rear View of Maintenance Bypass Cabinet with Output Transformer (GVSBPOT100T)

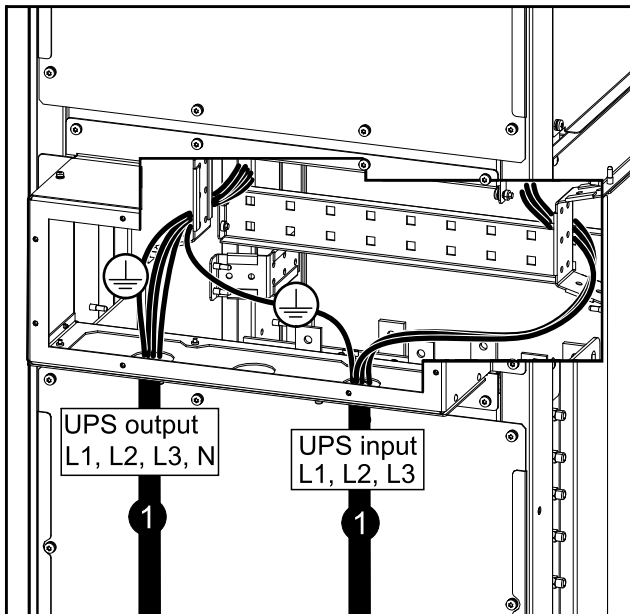

Rear View of Maintenance Bypass Cabinet without Transformer (GVSBP100T)

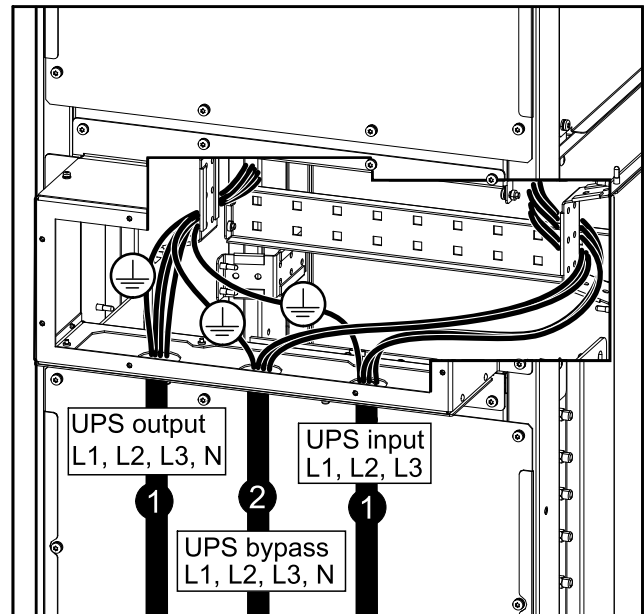

3. Connect the UPS input cables to the PE busbar and UIB.
4. **For maintenance bypass cabinet without transformer (GVSBP100T) with dual mains:** Connect the UPS bypass cables to the PE busbar, SSIB, and the N busbar.

5. Connect the UPS output cables to the PE busbar, UOB, and the N busbar.

Maintenance Bypass Cabinet with Output Transformer (GVSBPOT100T)

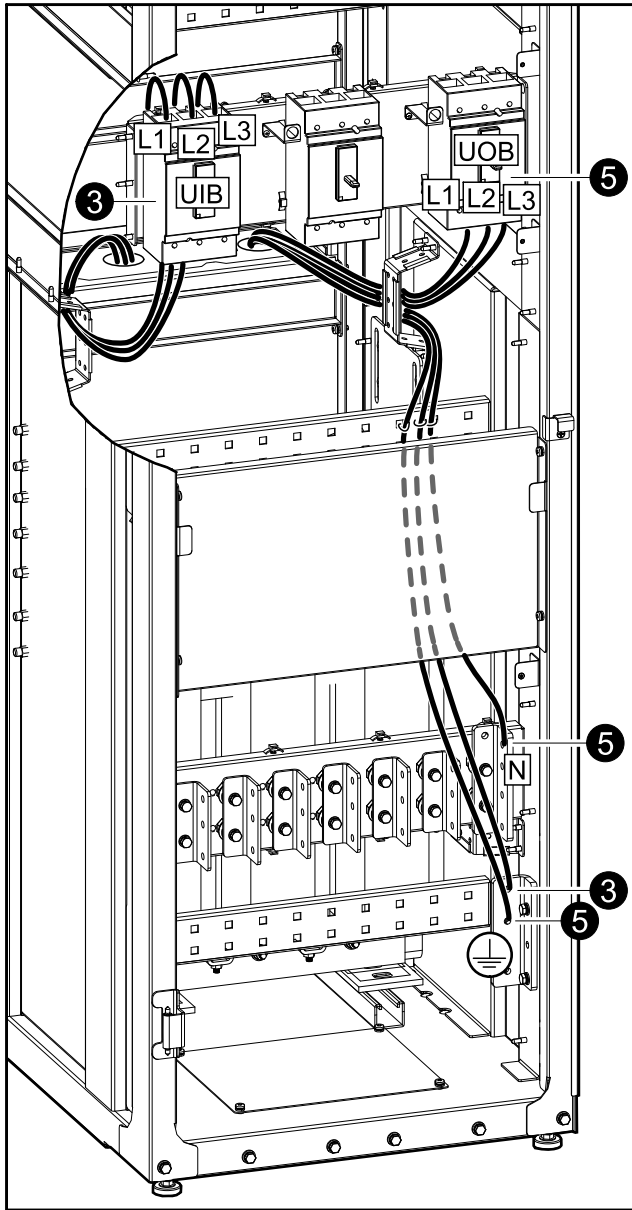

Maintenance Bypass Cabinet without Transformer (GVSBP100T)

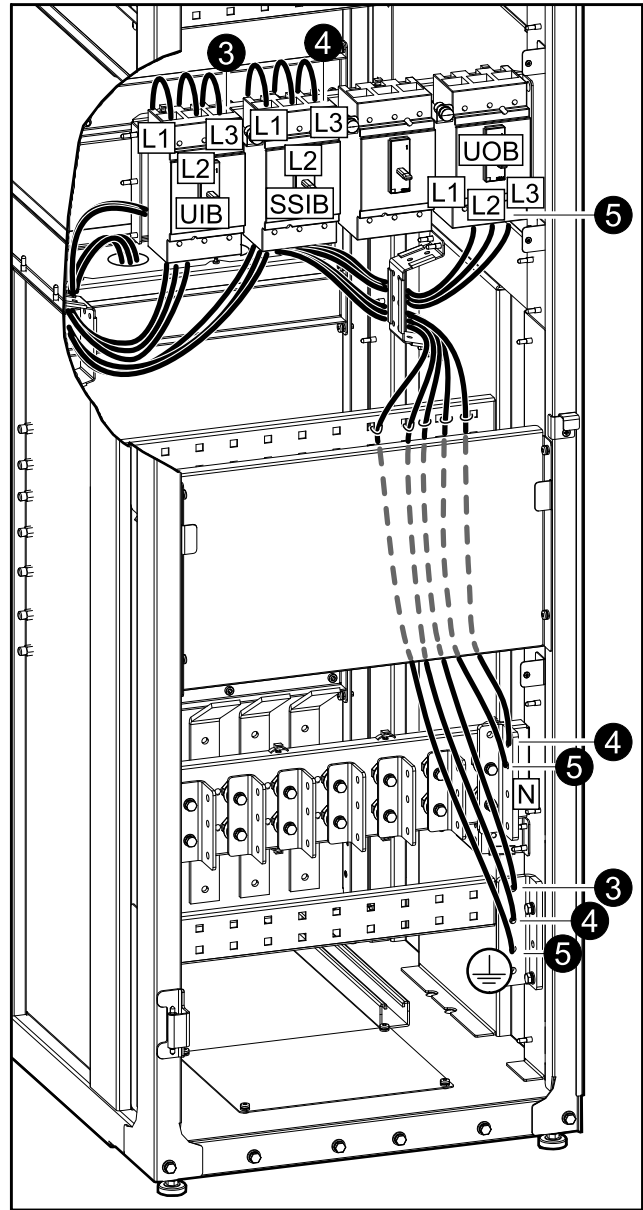

6. Reinstall the rear plate on the conduit box.
7. When the UPS has been installed, route the UPS input cables, the UPS bypass cables, and the UPS output cables in through the conduit box on the UPS. Follow the UPS installation manual to connect the UPS input cables, the UPS bypass cables, and the UPS output cables in the UPS.

Interconnect the UPS and the Maintenance Bypass Cabinet

Use installation kit GVSOPT032 for this procedure.

NOTE: In installation sites where there is limited rear clearance, ensure to finish the rear connections on the UPS before pushing it into the final position.

1. Push the UPS and the maintenance bypass cabinet into the final position. For seismic anchoring, ensure that the rear anchoring bracket connects to the rear anchor.

Rear View

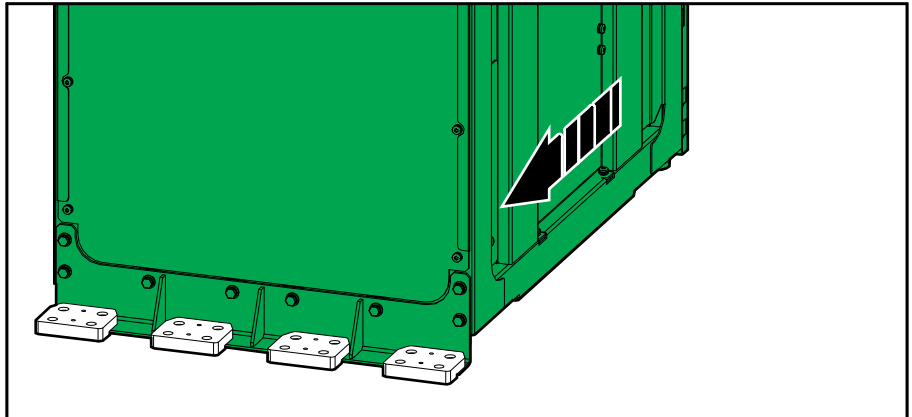

2. Lower the front and rear leveling feet on the UPS and the maintenance bypass cabinet with a wrench until they connect with the floor. Use a bubble-leveler to check that the UPS and the maintenance bypass cabinet are level.

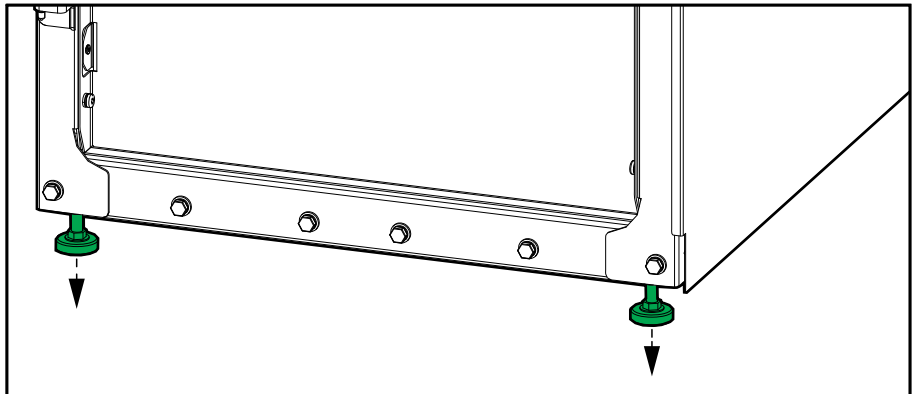

NOTICE

RISK OF EQUIPMENT DAMAGE

Do not move the cabinet after the leveling feet have been lowered.

Failure to follow these instructions can result in equipment damage.

3. Install the top and bottom baying brackets between the UPS and the maintenance bypass cabinet.

Front View of the UPS and the Maintenance Bypass Cabinet

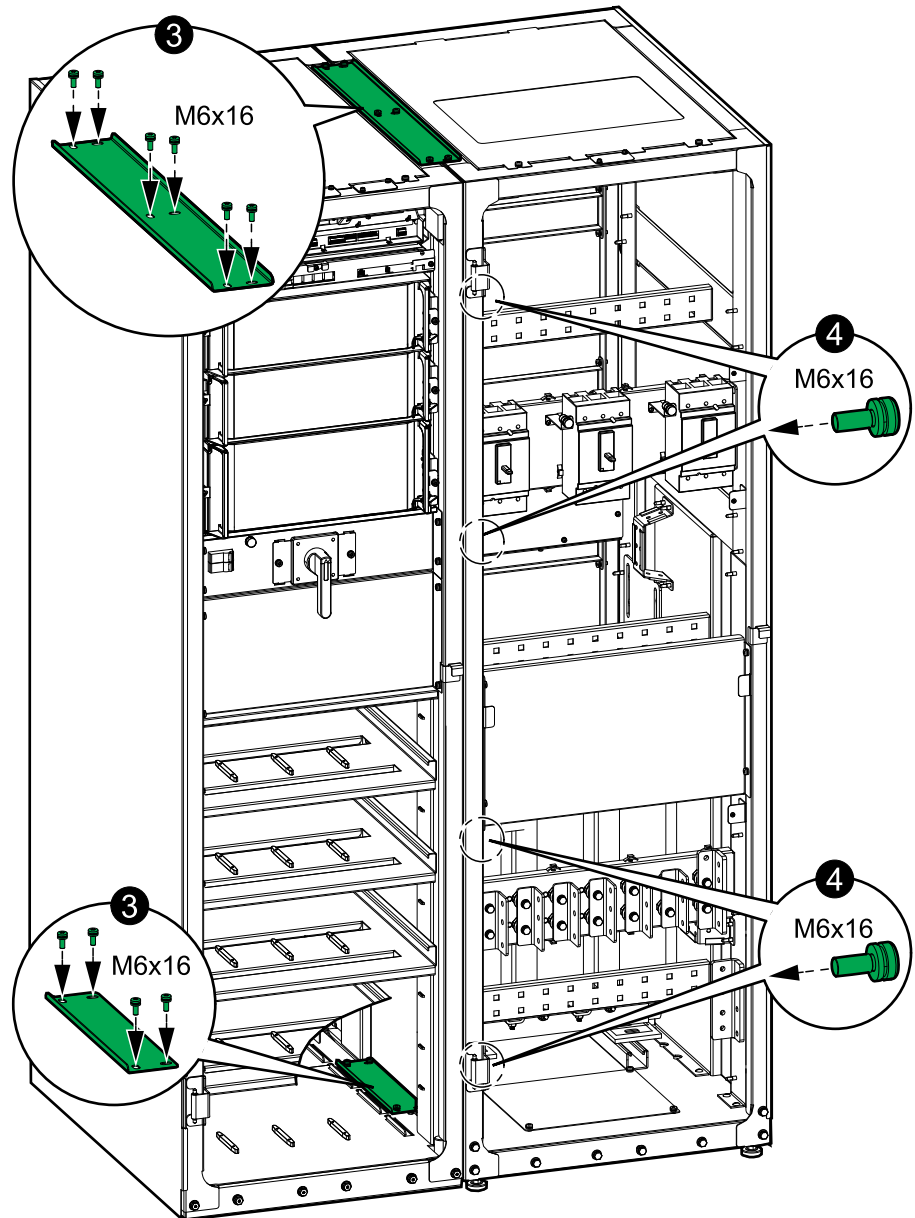

4. Install the four interconnection screws between the UPS and the maintenance bypass cabinet.

Connect the Power Cables on the Maintenance Bypass Cabinet with Output Transformer (GVSBPOT100T)

NOTE: For top cable entry, route the power cables in front of the horizontal brackets in the top and middle of the maintenance bypass cabinet. For bottom cable entry, route the power cables in front of the horizontal bracket in the bottom of the maintenance bypass cabinet. This is to ensure correct separation from the transformer.

1. Route the input cables through the top or bottom of the maintenance bypass cabinet and connect to the PE busbar and the input busbars.

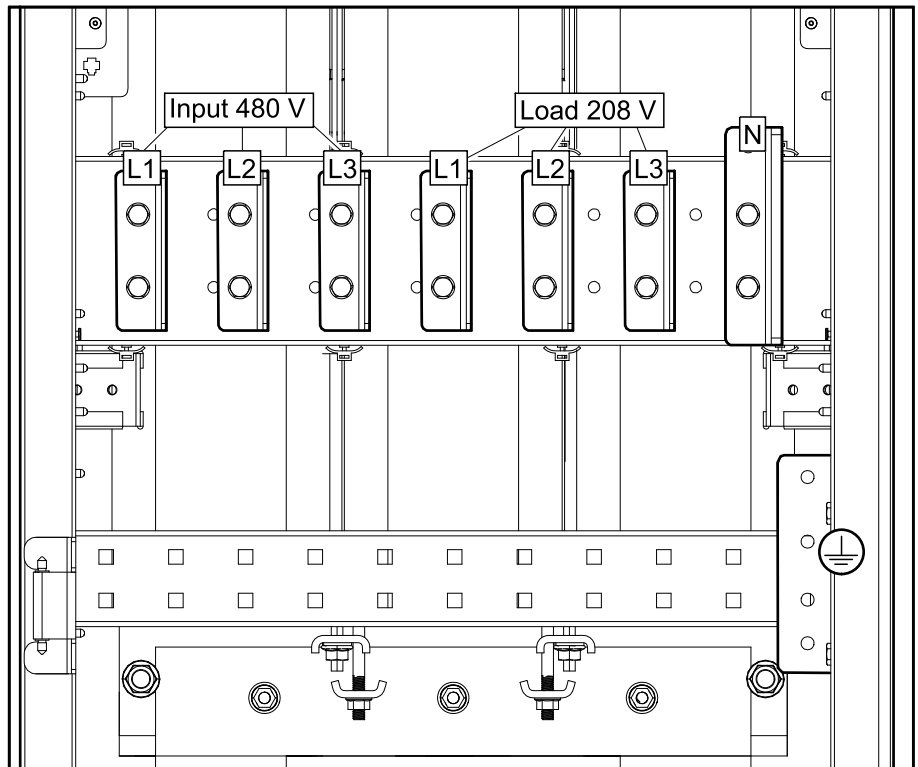

2. Route the load cables through the top or bottom of the maintenance bypass cabinet and connect to the PE busbar, the load busbars, and the N busbar.
3. Fasten the power cables to the horizontal bracket in the top and middle or bottom of the maintenance bypass cabinet with cable ties.
4. Follow the UPS installation manual to connect the DC cables directly in the UPS.

Connect the Power Cables on the Maintenance Bypass Cabinet without Transformer (GVSBP100T)

NOTE: For top cable entry, route the power cables in front of the horizontal brackets in the top and middle of the maintenance bypass cabinet. For bottom cable entry, route the power cables in front of the horizontal bracket in the bottom of the maintenance bypass cabinet.

1. Route the input cables through the top or bottom of the maintenance bypass cabinet and connect to the PE busbar and the input busbars.

For single mains systems: Connect the input cables to the N busbar.

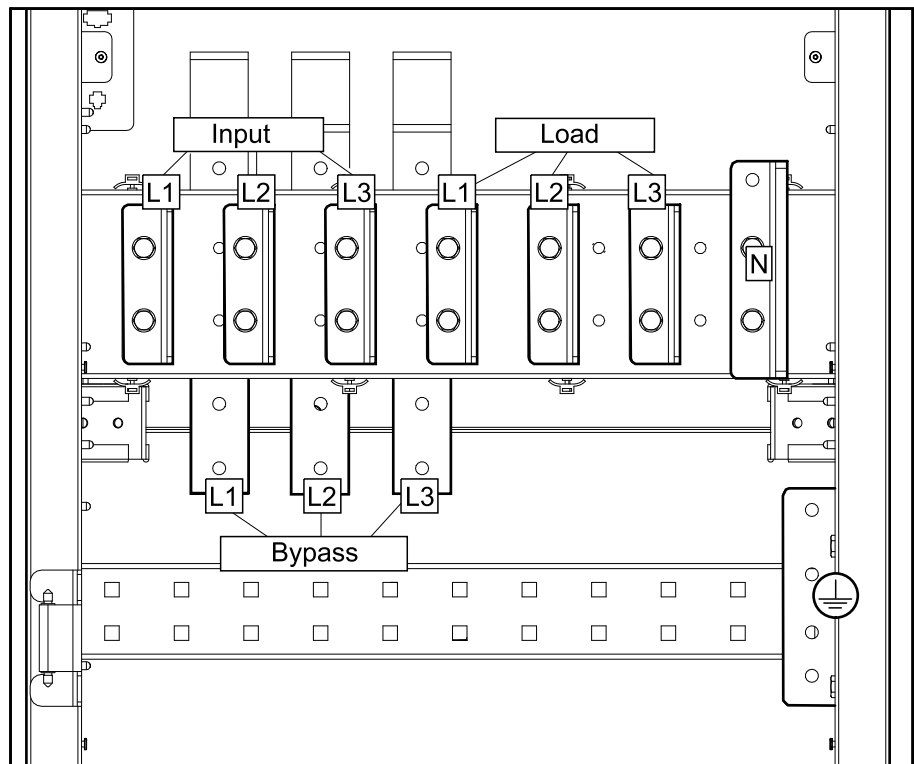

2. **For dual mains system:** Route the bypass cables through the top or bottom of the maintenance bypass cabinet and connect to the PE busbar, the bypass busbars, and the N busbar.
3. Route the load cables through the top or bottom of the maintenance bypass cabinet and connect to the PE busbar, the load busbars, and the N busbar.
4. Fasten the power cables to the horizontal bracket in the top and middle or bottom of the maintenance bypass cabinet with cable ties.
5. Follow the UPS installation manual to connect the DC cables directly in the UPS.

Connect the Signal Cables

NOTE: The signal cable 0W13196 (transformer thermal sensor) is only needed in a maintenance bypass cabinet with a transformer.

1. Route the signal cables 0W76867 (breaker indicator lights), 0W13196 (transformer thermal sensor), and 0W76866 (breaker AUX switches) from the cable connection point in the maintenance bypass cabinet and into the UPS through the opening in the top left side.

NOTE: Route the signal cables as far away from the power cables as possible to avoid EMC disturbance.

Front View of the UPS and the Maintenance Bypass Cabinet

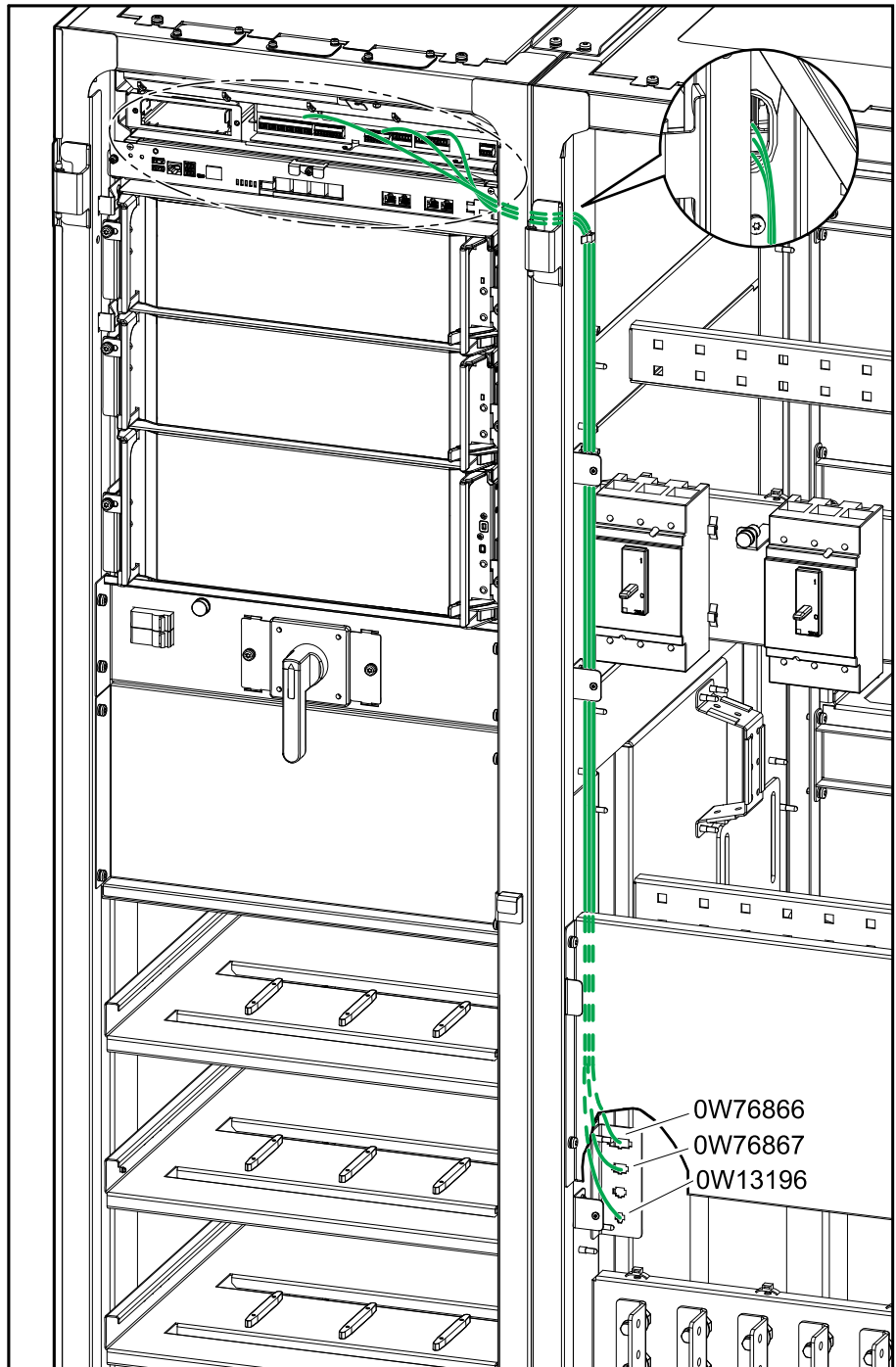

2. Connect the Class 2/SELV signal cables 0W76867 and 0W13196 to board 640-4864 in the UPS as per your configuration.

3. Connect the non-Class 2/non-SELV signal cable 0W76866 to board 640-4843 in the UPS as per your configuration. See UPS installation manual for board overview.

Single Mains

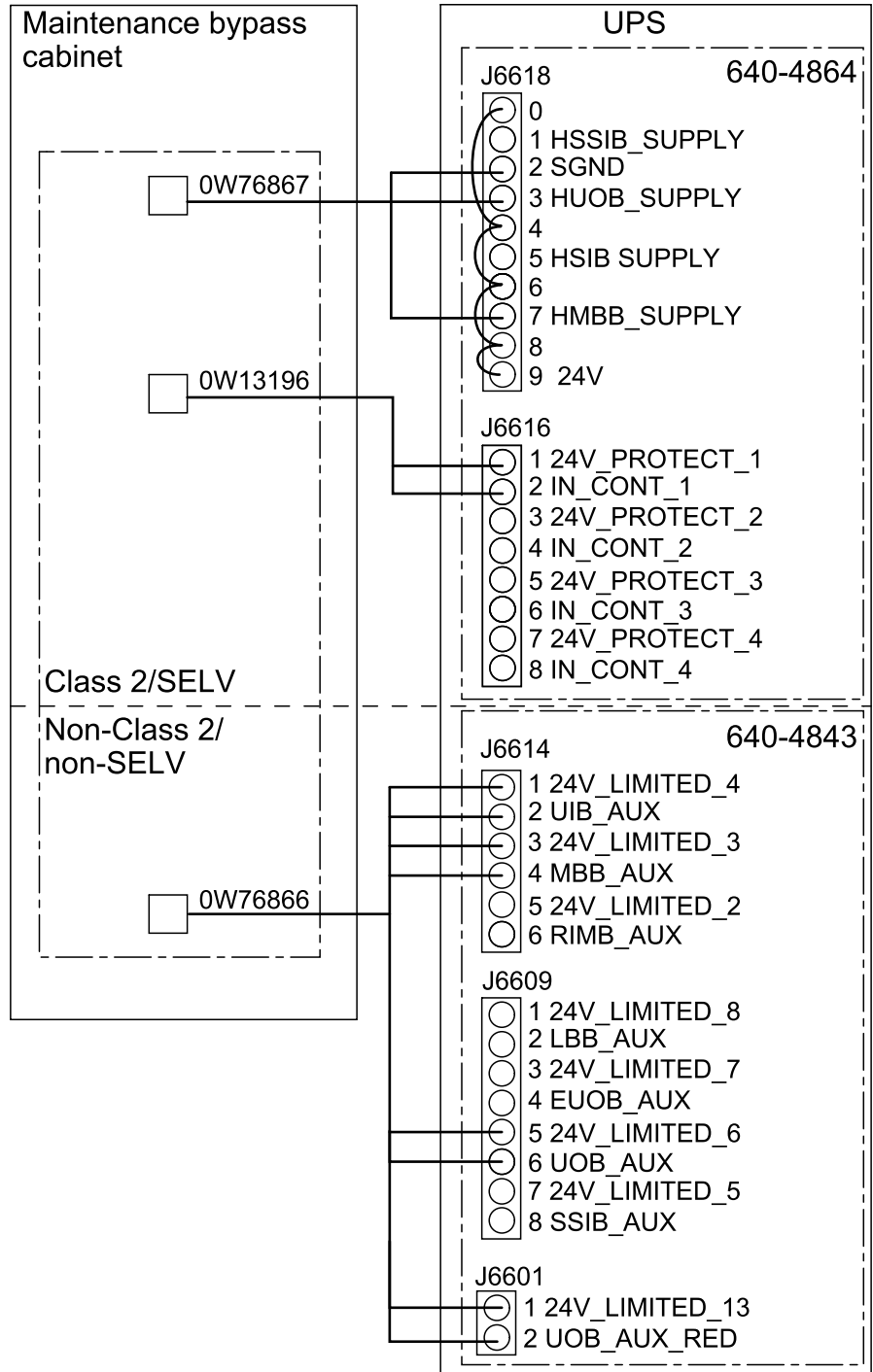

Dual Mains with SSIB Breaker Installed

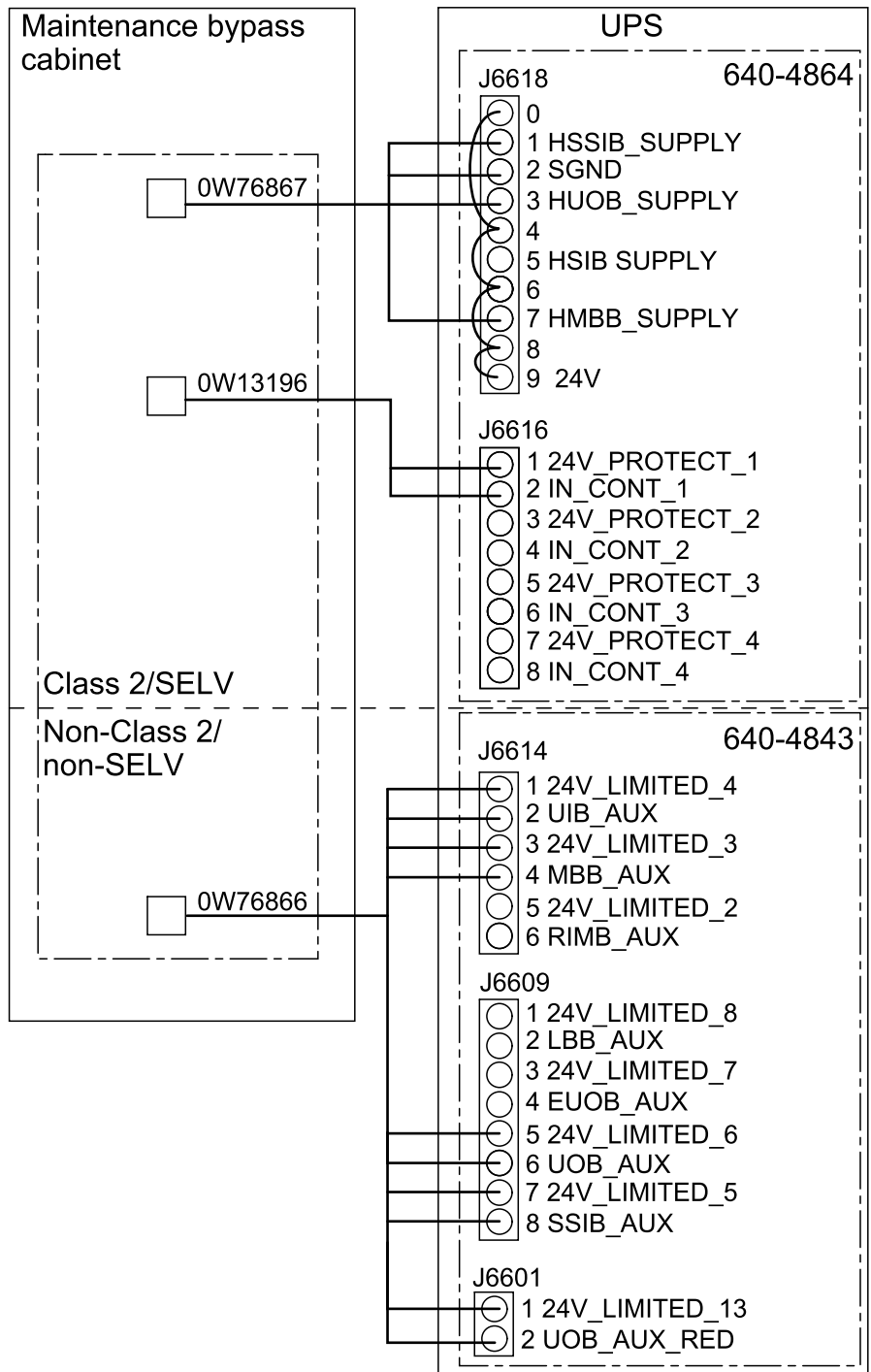

Final Installation

1. Reinstall the indicated plates/covers.
 - a. **For maintenance bypass cabinet without transformer (GVSBP100T) with dual mains:** Remove the two knockouts for the SSIB breaker and SSIB breaker indicator light in the plates/covers before installing them.

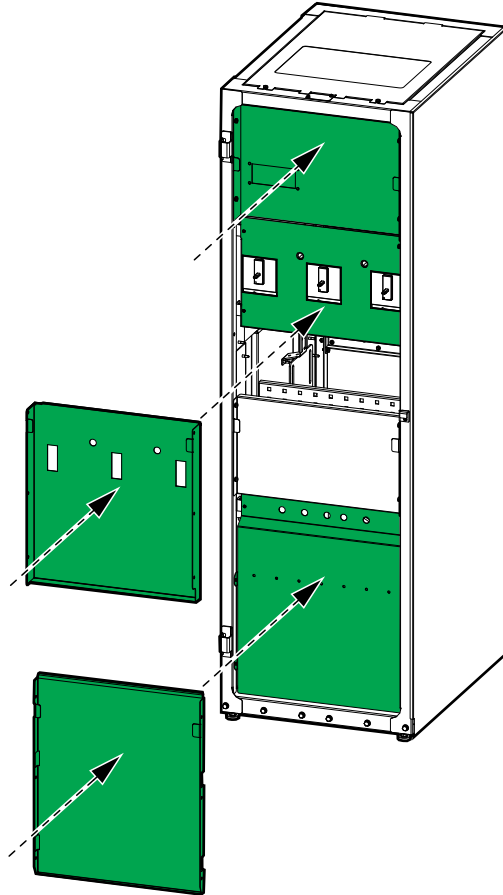

2. **For seismic anchoring:**
 - a. Install the front anchoring bracket on the maintenance bypass cabinet with the provided M8 bolts.
 - b. Mount the front anchoring bracket to the floor. Use appropriate hardware for the floor type – the hole diameter in the front anchoring bracket is $\varnothing 13$ mm. Minimum requirement is M12 grade 8.8 hardware.

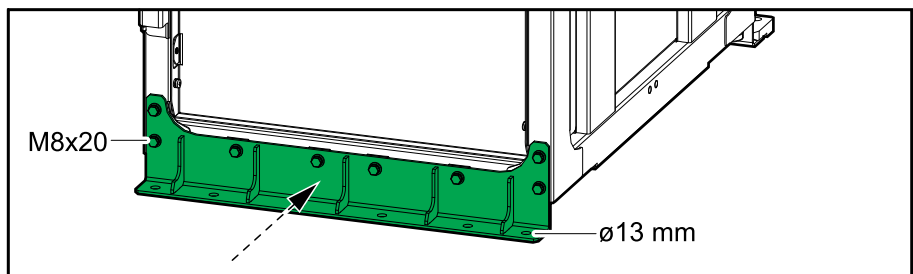

3. Reinstall the door.
4. Follow the UPS installation manual to connect the power cables from the maintenance bypass cabinet in the UPS and to complete the rest of the UPS installation.

Schneider Electric
35 rue Joseph Monier
92500 Rueil Malmaison
France

+ 33 (0) 1 41 29 70 00



* 9 9 0 - 6 2 3 9 A - 0 0 1 *

As standards, specifications, and design change from time to time,
please ask for confirmation of the information given in this publication.

© 2020 – 2020 Schneider Electric. All rights reserved.

990-6239A-001