



alsy
www.alsysteel.com

PRE-ENGINEERED METAL BUILDINGS ERECTION AND INSTALLATION GUIDE



alsy

www.alsysteel.com

PRE-ENGINEERED METAL BUILDINGS ERECTION AND INSTALLATION GUIDE

The methods & procedures suggested by this Erection Guide are fundamental in nature and present good, safe erection practices. They can, and should, be modified when necessary to adapt to special conditions or circumstances. Before beginning, familiarize with the building details and sequence of erection. Some buildings need complex sequence of erection; those must be processed & assessed by specialist before execution.

1st Step - ANCHOR BOLTS INSTALLATION AND CONTROL

All anchor bolts in the concrete pedestals must be cast in compliance with the Alsy Steel's Anchor bolt Setting Plan Drawing marked "Issued for Construction". This must be done by the assigned civil work contractor and should be checked by Alsy Steel's Erection specialist prior to move in

or start of erection. The responsibility and accuracy of placement of all anchor bolts rests to the Customer and his assigned civil contractor. **Using Total Station during installation will reduce the total error in critical dimensions.**

Prior to starting the erection, all the anchor bolts cast must be thoroughly double checked for the following such as: location, dimensions, orientation, projection/level, center to center distance and the squareness of the structure.

Ensure all anchor bolts leveling nuts were fixed according to the required level and projection.

Any discrepancies found must be reported immediately and require action must be taken by the assigned civil contractor to immediately rectify.

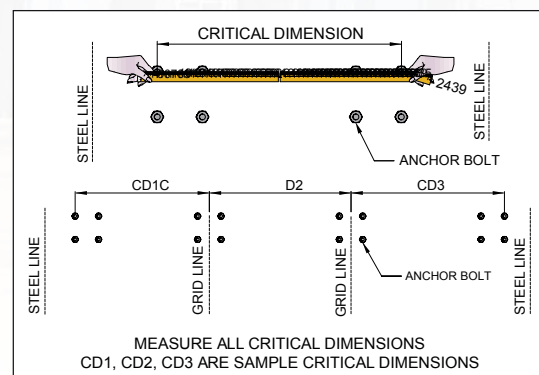
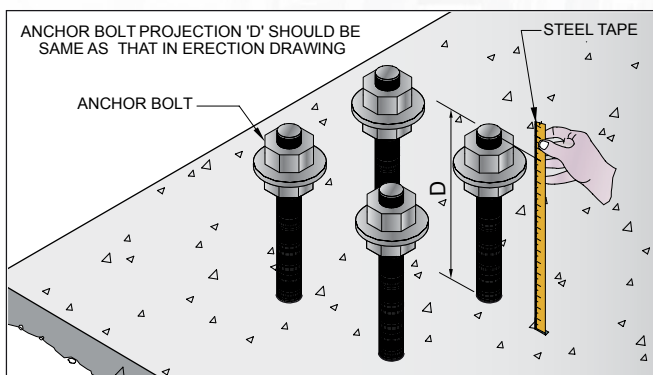

2nd Step - UNLOADING, TRANSPORT AND STORING MATERIALS

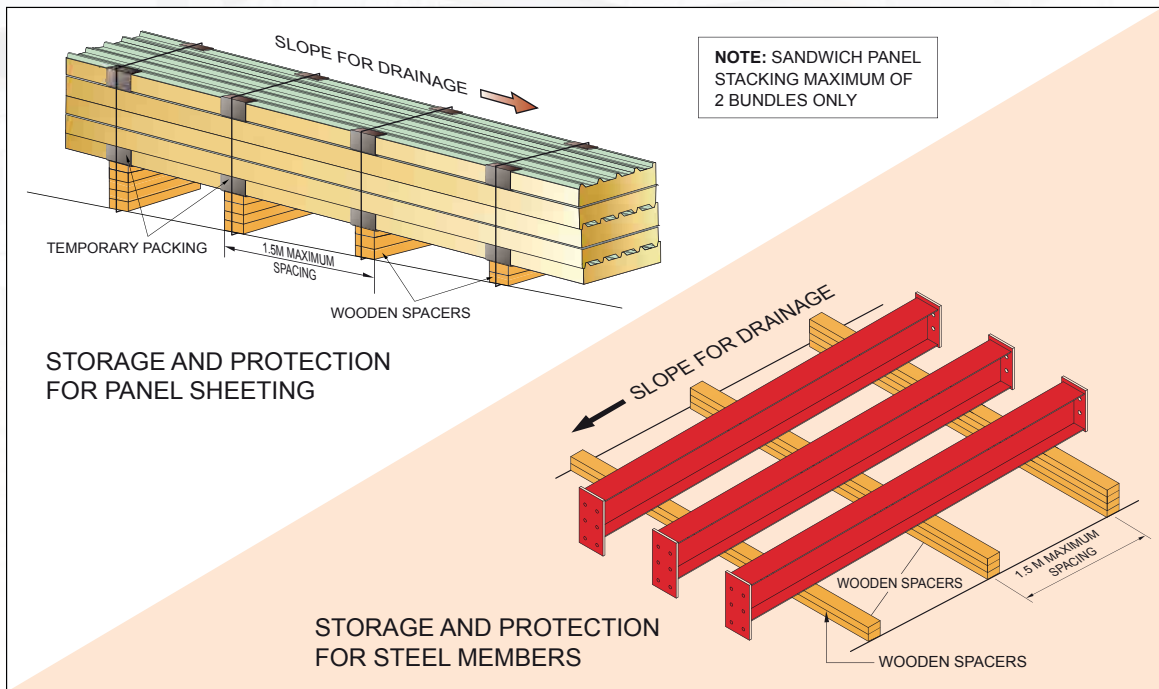
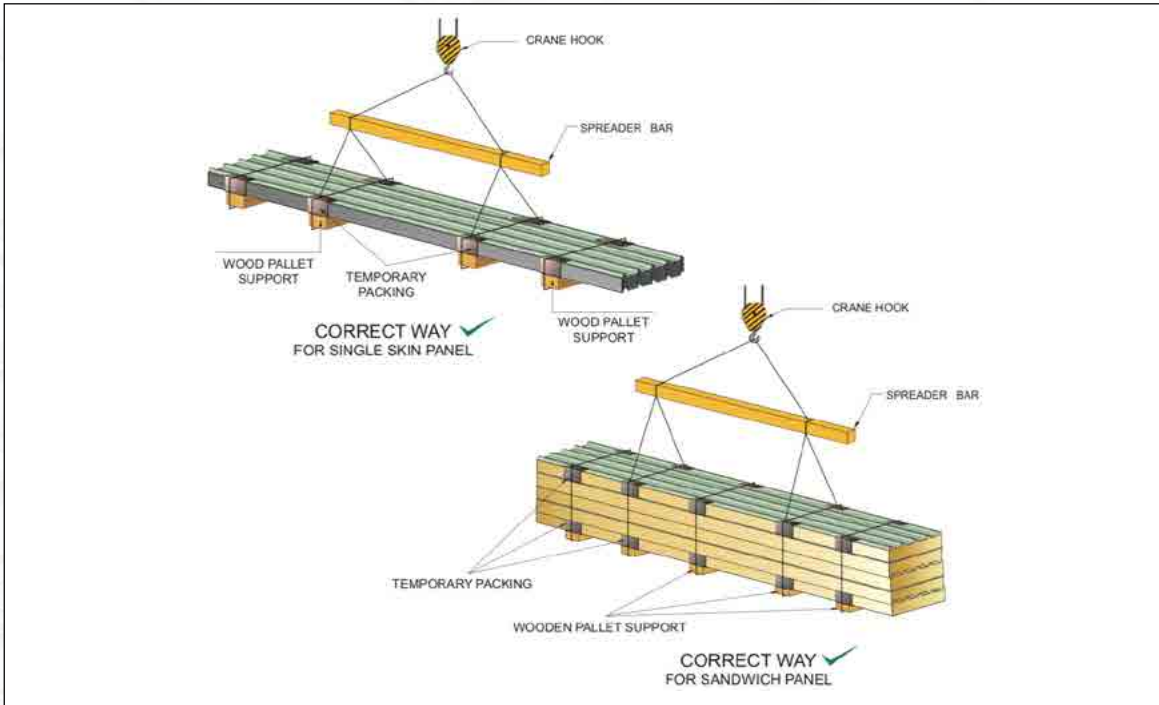

3rd Step - SEGREGATION, PREPARATION AND ASSEMBLING

According to erection drawings all steel members has to be segregated to concerned axes. It will be so helpful for erector team and gain time sorting the members.

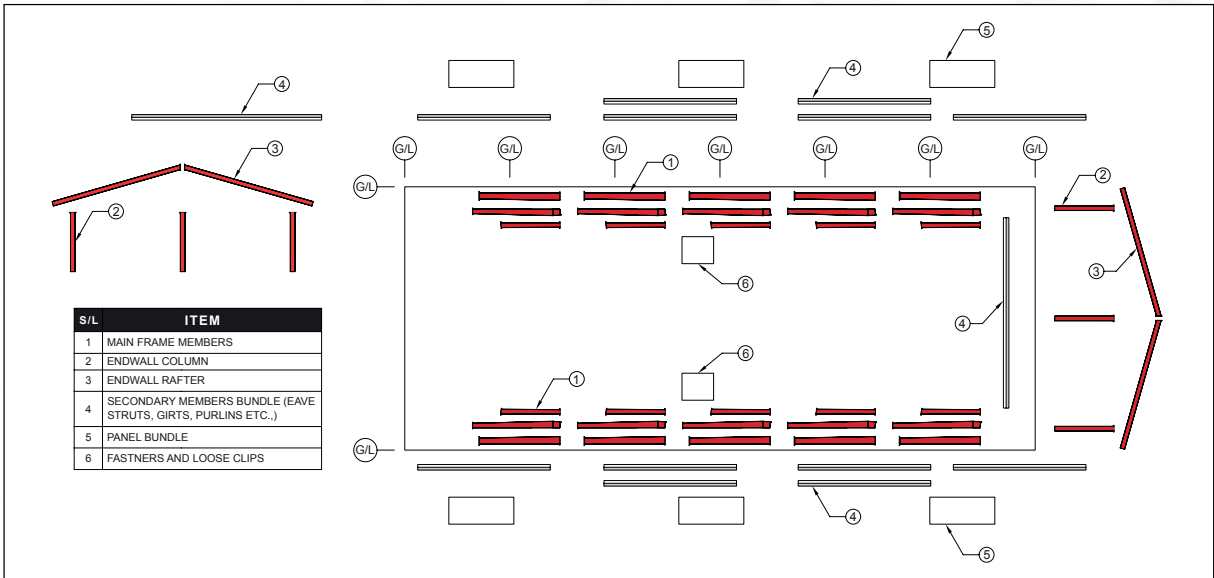

4th Step - ERECTION SEQUENCE

For different building systems the fundament erection procedure is followed with detailed sequencing system referring to particular building size & weight. Erection has to start with the braced bay.

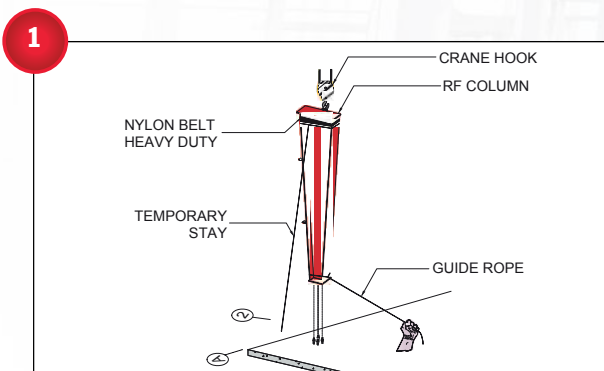

[Lift the column with sufficient guy wire rope]

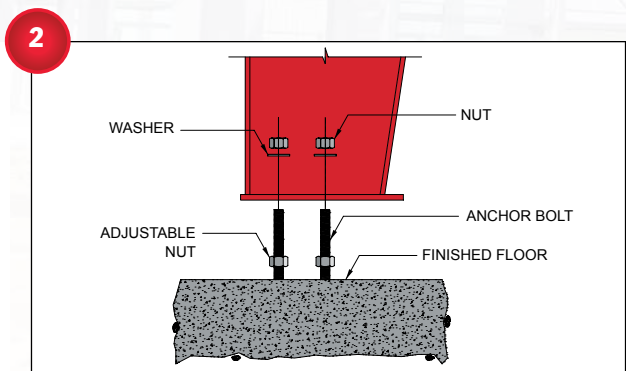

[Position the column on levelling nut]

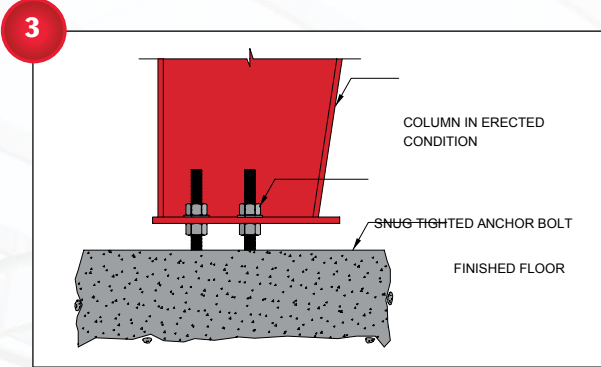

[Tightened the nut over supplied washer after plumbing the column]

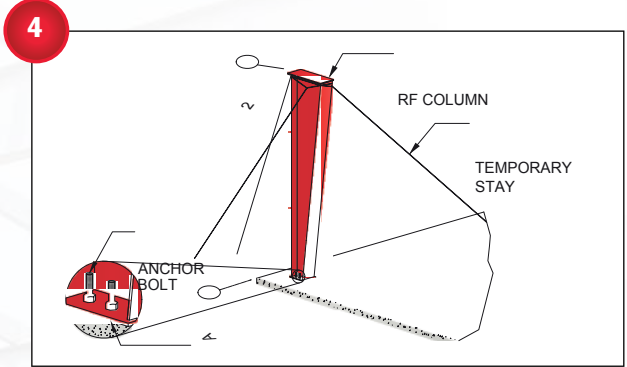

[Tie all the temporary bracings before releasing the crane load]

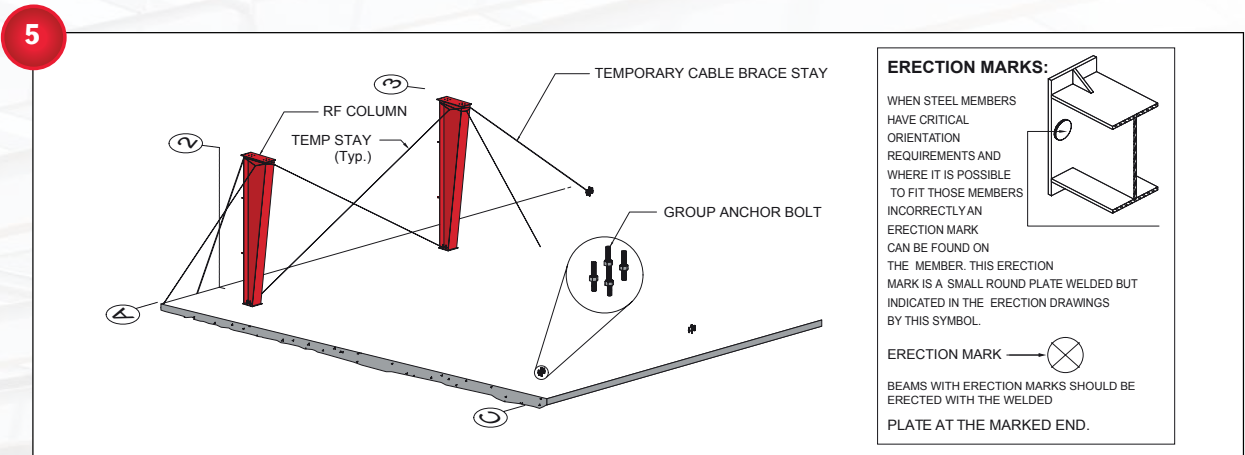

[Similarly erect other columns]

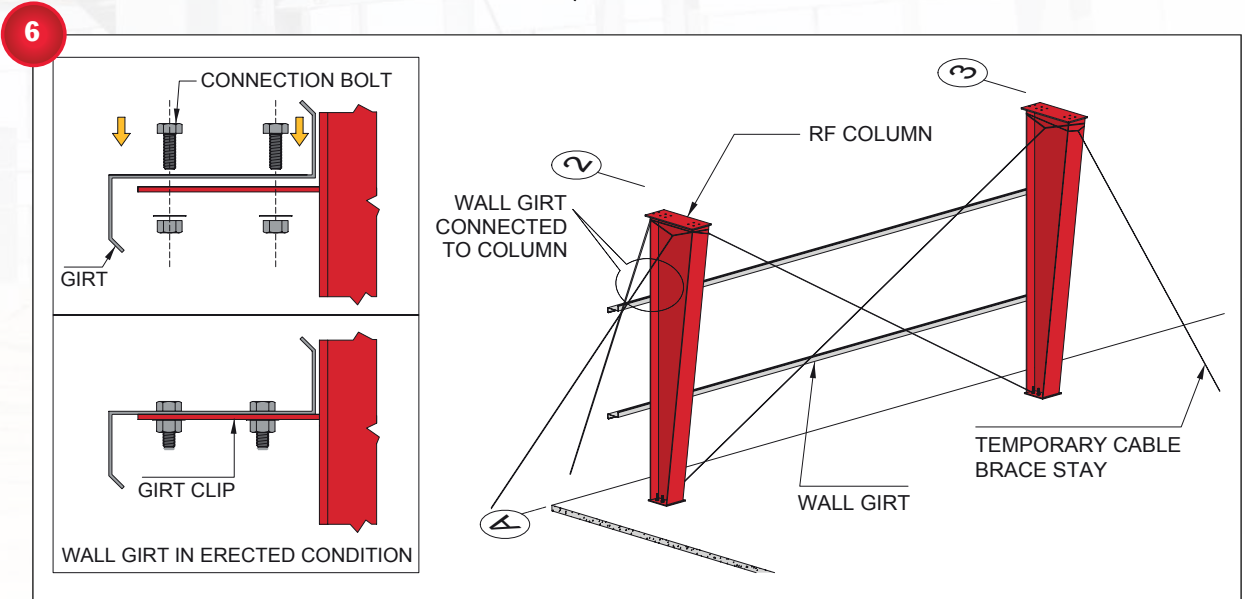

[Install the side wall girts]

7

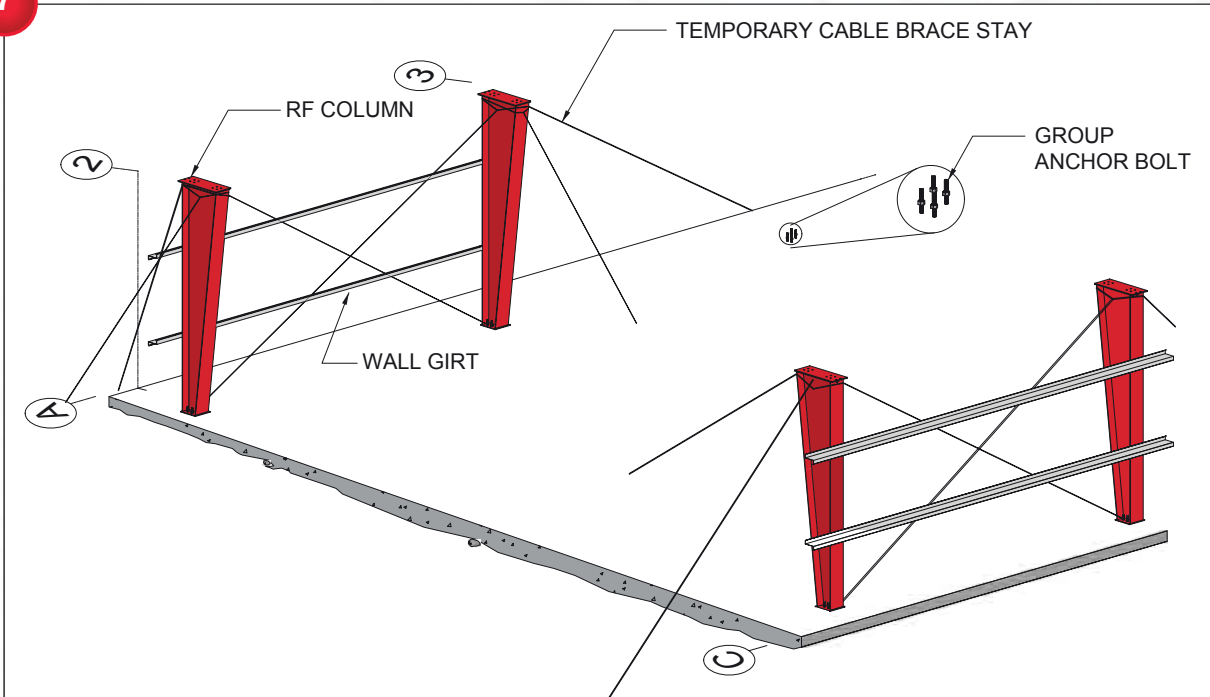

[Repeat the steps on opposite side wall]

8

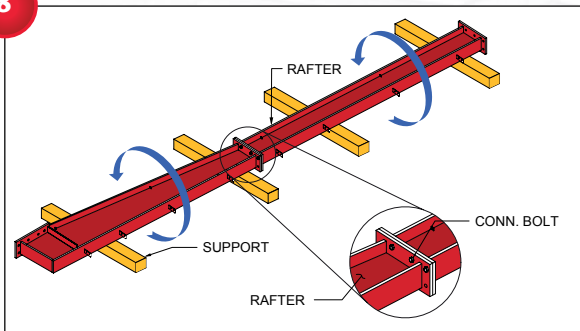

9

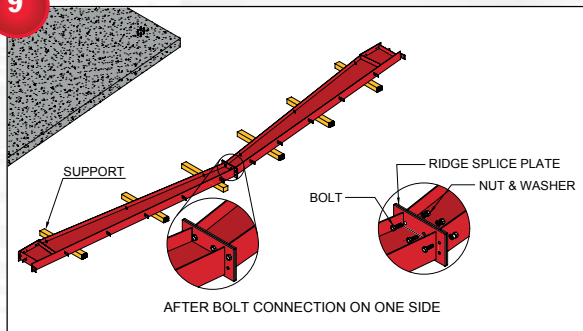

[Assemble the rafters, don't forget to install the ange braces & tighten the splice joints]

10

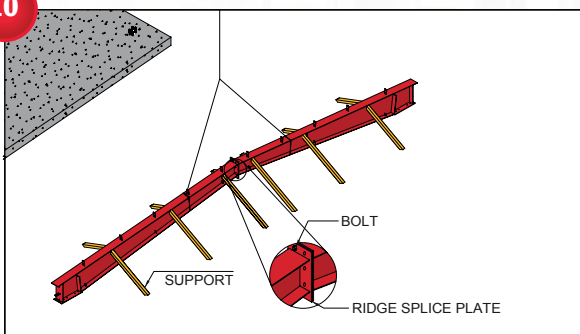

11

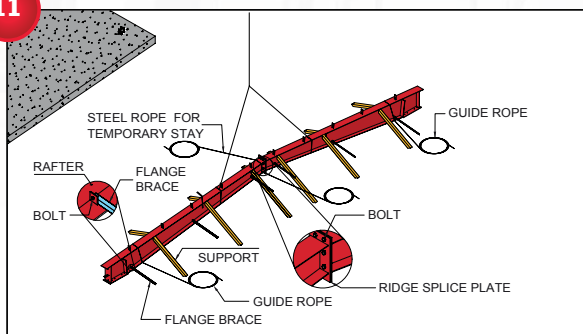

[Position & rig the rafter assemblies]

12

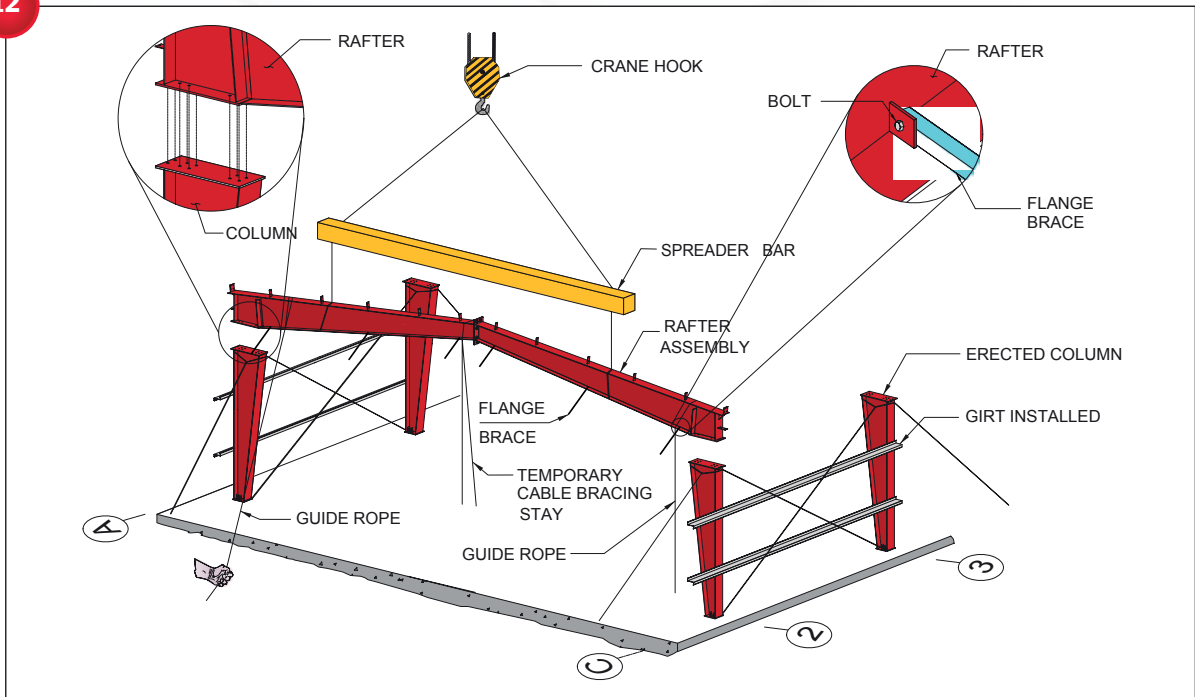

[Lift & erect the rafter assembly, ensure to tie enough guy wire ropes & tag lines]

13

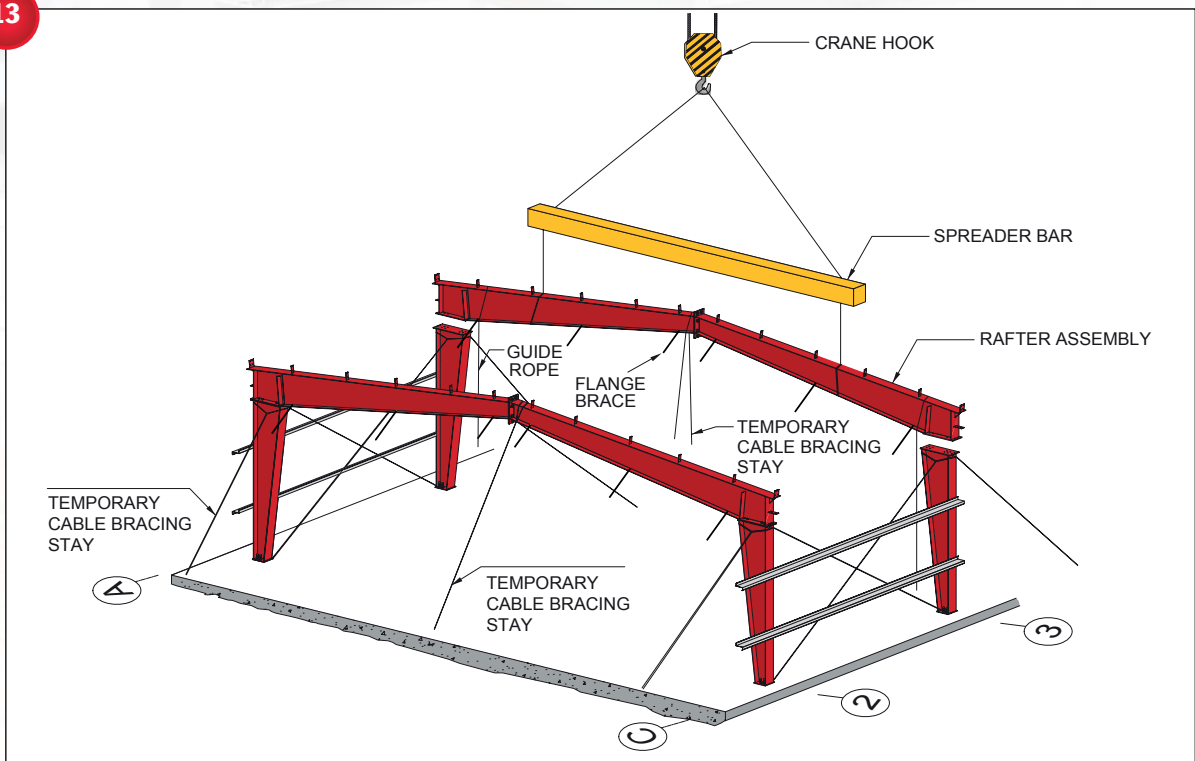

[Similarly lift & erect the other rafter assembly of the 1st braced bay]

14

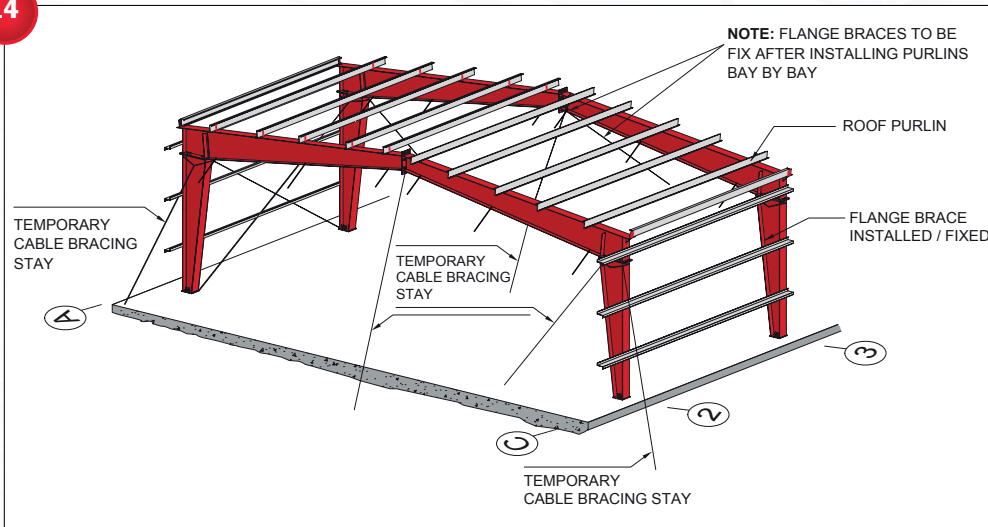

[Fill the purlins in between]

15

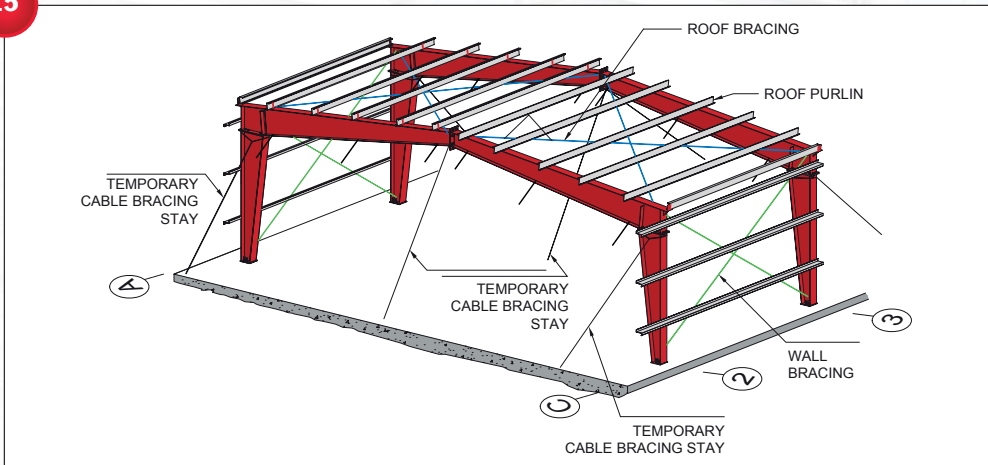

[Install all the roof & wall bracings and align the bay]

16

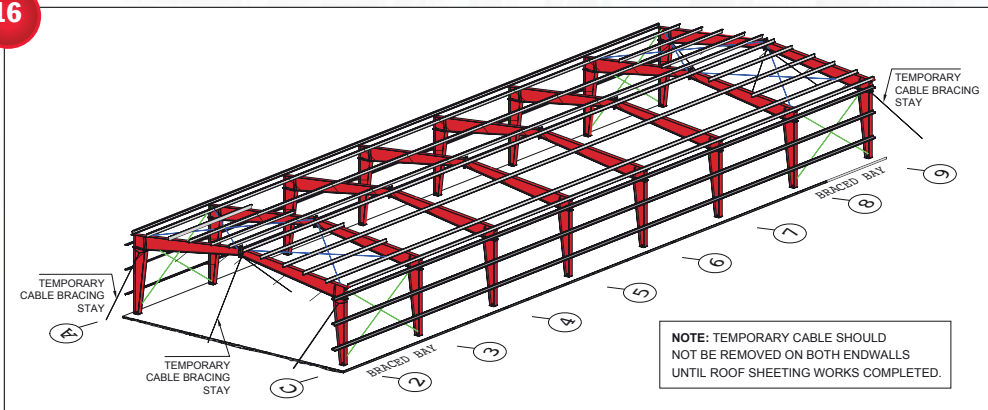

[Similarly erect the other frames on grids]

Note: For some areas and countries which has seismic requirements or in offshore region or height of the building is more than 9m, Also is using tubular sections for bracing instead of rods.

17

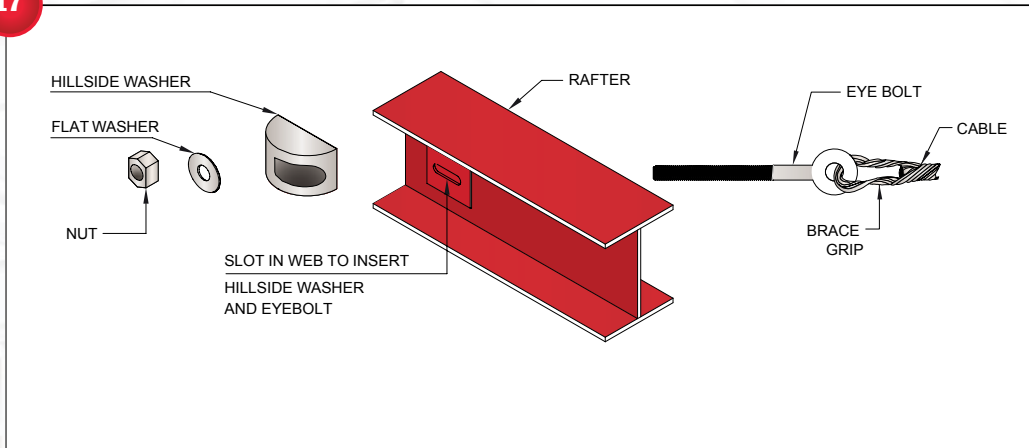

[Details of installing hill side washer for cable bracings or rod bracings]

18

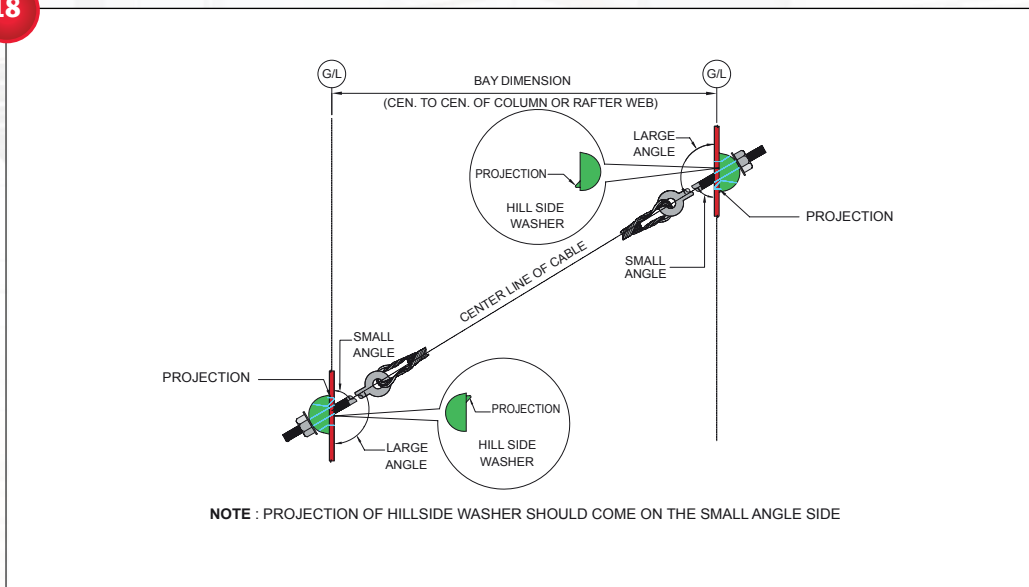

[Details of installing hill side washer for cable bracings or rod bracings]

19

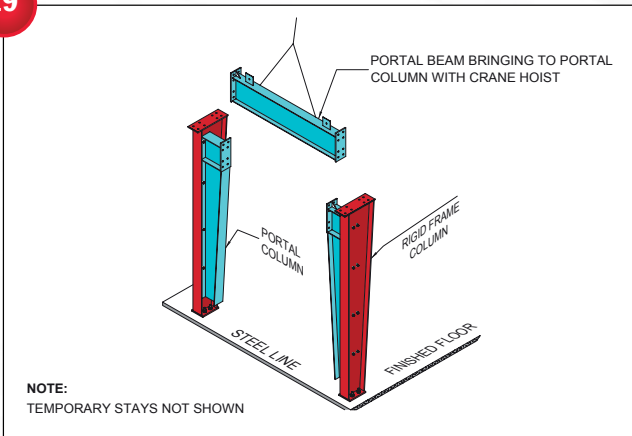

[Details of installing portal bracing]

20

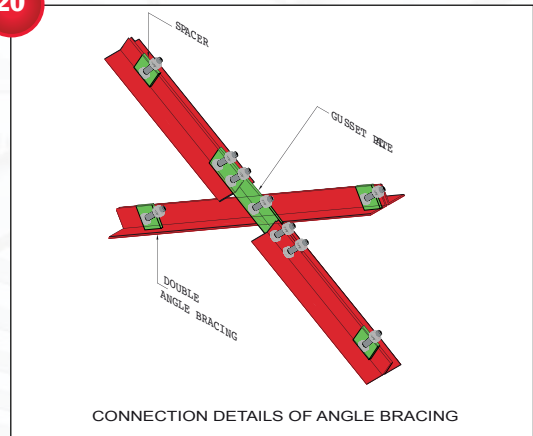

[Details of installing angle bracing]

21

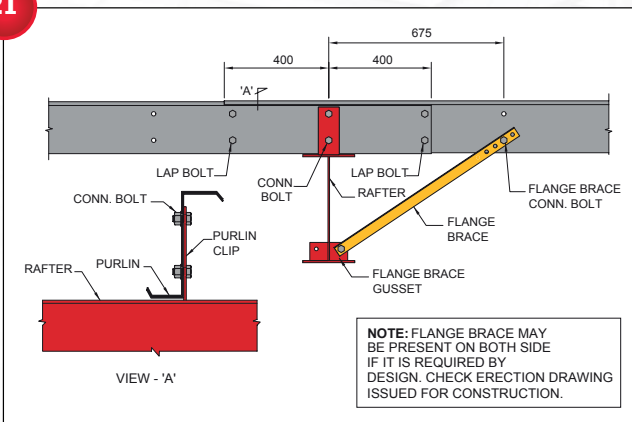

[Details showing purlin overlap, angle brace & lapping bolts]

22

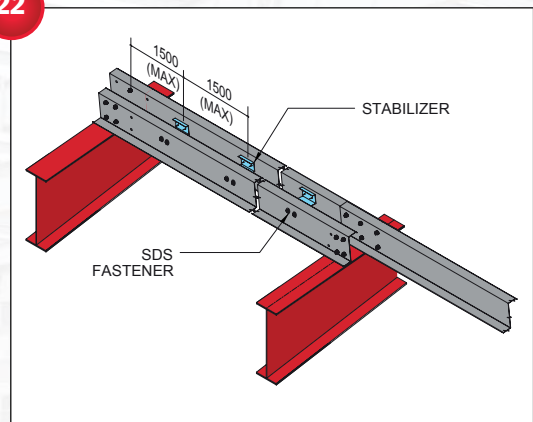

[Details of installing strut purlin with stabilizers]

5th STEP - BOLT TIGHTENING AND INSPECTION PROCEDURE

TIGHTENING:

- Ensure all connection bolts have been installed as per issued for construction drawings; verify the sized mentioned in the erection drawings.
- All the bolts should be brought to Snug tight position before tensioning. (Position the bolts to snug tight by manual operation using an ordinary spud wrench. A full effort of an erector using an ordinary spud wrench would bring the bolt to a snug tight position. No wrench

extension or long wrenches should be used to bring the bolt to a snug tight position in order to avoid tensioning. A 300 mm long spud wrench is normally used)

- Once the snug tight position is achieved, the outer face of the nuts shall be match-marked with the help of a permanent marker pen.
- After marking further tightening / tensioning shall be proceed until the desire nut rotation meets requirement shown in Table 8.2 (Tightening shall be carried out Manually by extending the spud wrench length or increasing the number of erectors to two; electric impact wrench can also be used, but ensure to avoid over tensioning)

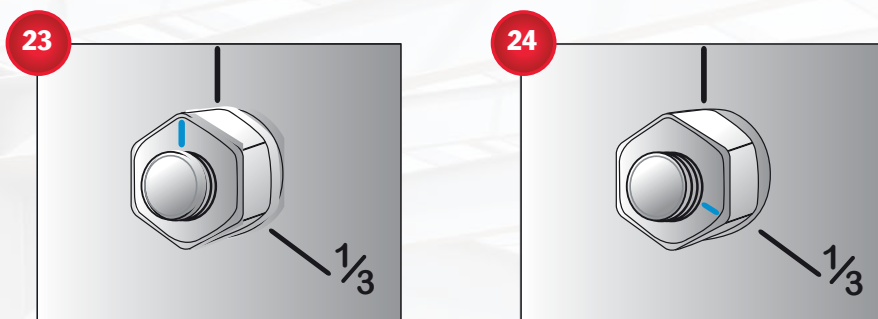

[Position of nuts before & after turn off the nut method]

Table: Nut Rotation from Snug-Tight Condition for Turn-of-Nut Pretensioning

Bolt Length ^c	Disposition of Outer Face Bolted Parts		
	Both faces normal to bolt axis	One face normal to bolt axis, other sloped not more than 1;20 ^d	Both faces sloped not more than 1;20 from normal to bolt axis ^d
Not more than 4d _b	1/3 turn	1/2 turn	2/3 turn
More than 4d _b but not more than 8d _b	1/2 turn	2/3 turn	5/6 turn
More than 8d _b but not more than 12d _b	2/3 turn	5/6 turn	1 turn

- Nut rotation is relative to bolt regardless of the element (nut or bolt) being turned. For required nut rotations of 1/2 turn and less, the tolerance is plus or minus 30 degrees, for required nut rotations of 2/3 turn and more, the tolerance is plus or minus 45 degrees.
- Applicable only to joints in which all material within the grip is steel.
- When the bolt length exceeds 12 d_b, the required nut rotation shall be determined by actual testing in a suitable tension calibrator that simulates the conditions of solidly fitting steel.
- Beveled washer not used.

6th STEP - UNDER COLUMN GROUTING DETAILS

The civil contractor is responsible for providing and setting the non-shrink grout immediately after the erector has finished the erection of all steel members. The purpose of this material is not to allow uneven pedestal heights.

25

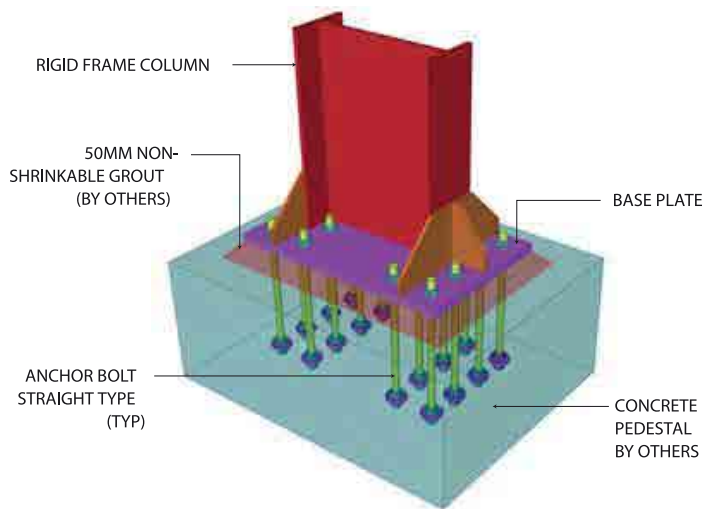

7th STEP - TOUCH UP PAINT

Touch up paint during & after erection is always a part of erection method statement. As scratched developed during erection / mechanical damages must be addressed immediately by proper surface preparation & application of proper coating to avoid corrosion.

8th - STEP - SINGLE SHEETING AND SANDWICH PANEL INSTALLATION

26

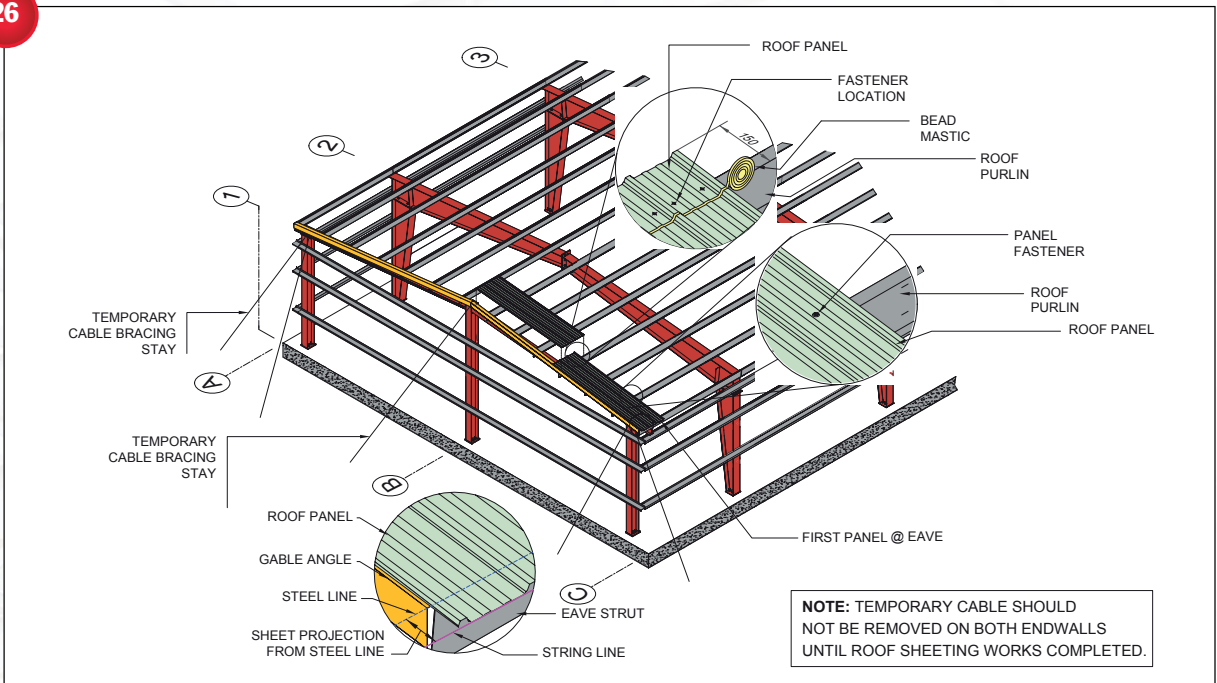

[Single skin panels laying, sealant & lapping details]

27



28

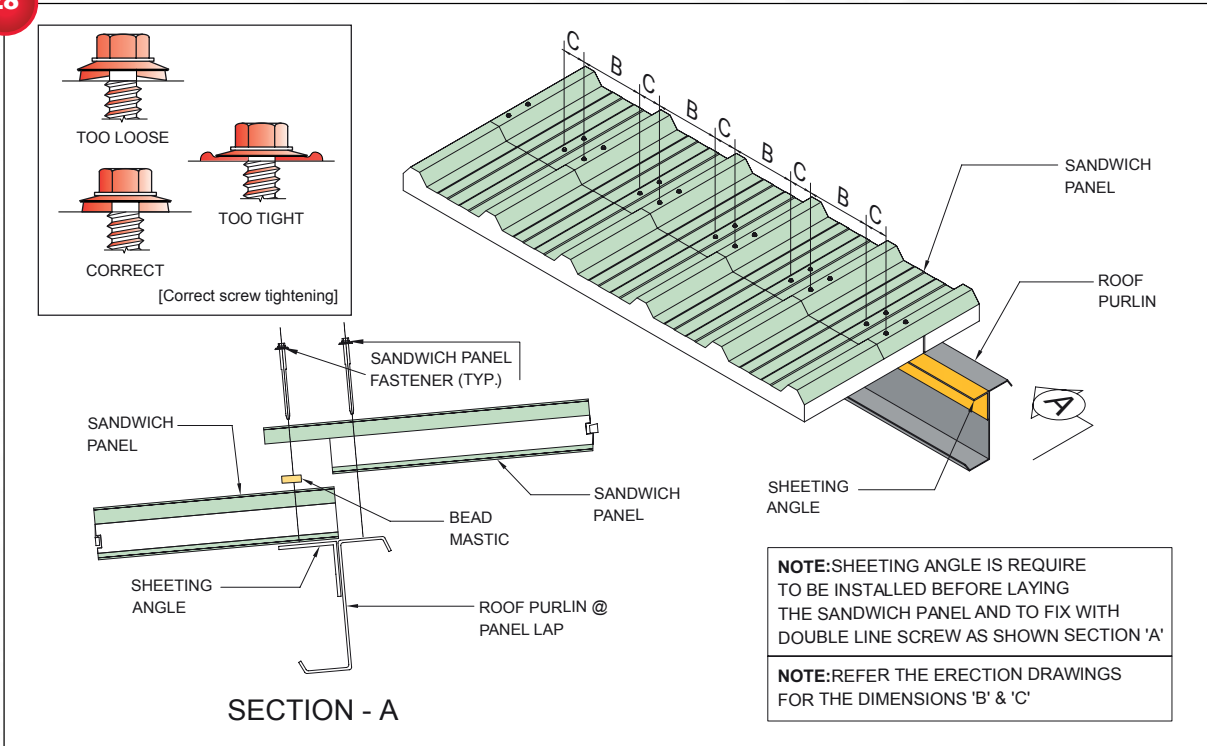

[Sandwich panels lapping, sealant & fastening details]

29

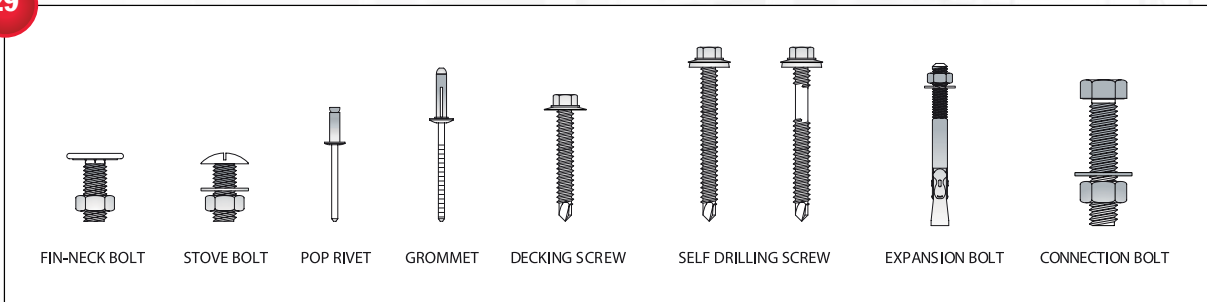



Giyimkent 16. Sokak No: 54 Esenler - ISTANBUL
Phone: +90 212 351 12 40 Fax: +90 212 351 12 35
www.tolay.com.tr · info@tolay.com.tr