

TOLAY STEEL

CONSTRUCTION AND PEB SYSTEM



PEB

PRE ENGINEERED BUILDING SYSTEMS

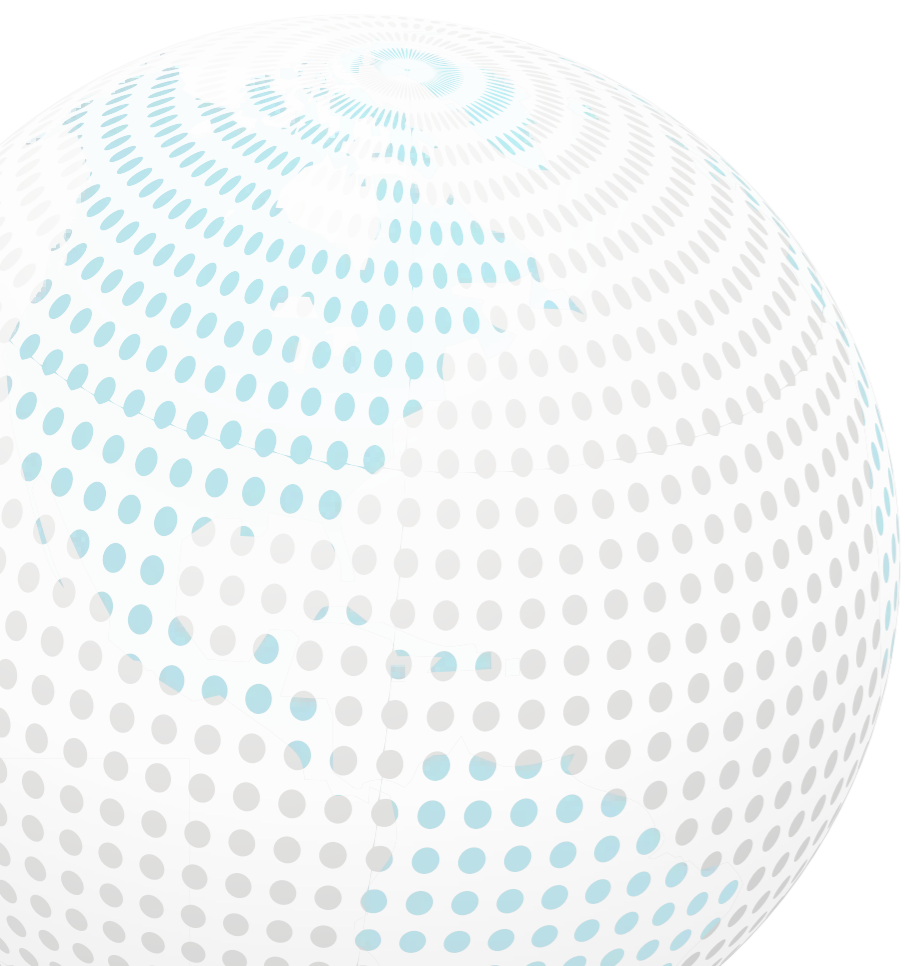

TOLAY STEEL
CONSTRUCTION AND PEB SYSTEM



**PRE ENGINEERED BUILDING
SYSTEMS**



HOW DID PEB COME INTO BEING?

Steel construction demands increased dramatically as such factors as time, economy, increasing storage and sheltering needs, duration, mountability and building's safety against earthquakes gained importance under the current conditions. However; the facts that design rules of the conventional method were not economical, the design didn't offer any features to buildings and ready-to-use hot mill elements were constantly dependent on prevented steel buildings from becoming widespread in international markets for many years.

The development enjoyed by information technologies and engineering in recent years offered modern solutions for building design and consequently the revolutionary PEB building design system came into being.

This innovative design system made important contributions to meeting steel construction needs and increasing market share throughout the world.

PEB system has increased its market share rapidly since its introduction to the market. It increased its market share up to 60% especially in the USA according to the report published by the Association of International Metal Manufacturers. In 1990s, PEB entered India which is one of the leading countries of the world in steel production by making foreign investments in this country. PEB's market potential reached 1.2 million tons and its present production capacity was determined to be 0.35 million tons/year. At the same time, PEB increases its market share in this country every year by 25 - 30 per cent.

WHAT IS PEB?

In conventional systems a single section big enough to compensate for the maximum stress is used while different stresses occur at each point of the frame constituting the building. This situation adds unnecessary weight on the building; increases the earthquake load falling onto it as well as increasing its cost and reduces building's elastic mobility.

PEB system arose from the need for removing such

disadvantages of the abovementioned conventional system. PEB is a modern building design system which sets forth the production of artificial profile sections in various sizes according to the capacity needed by construction elements by taking as a basis the fact that stress concentrations vary in the system constituting the building. This system lightens the building, provides it with an elastic and economical structure and removes the dependence on ready-to-use profiles.

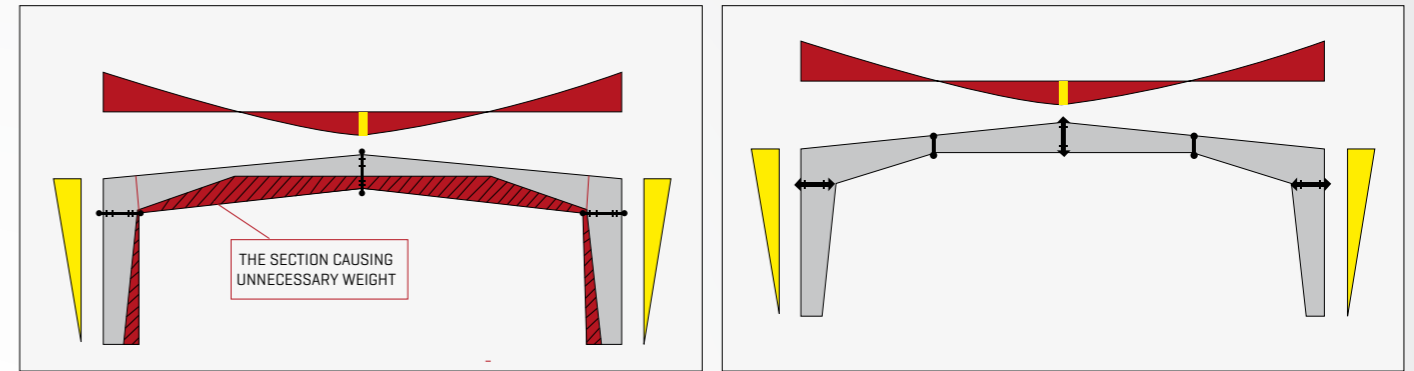

Conventional Steel Frame

Peb Steel Frame

*No more unnecessary weights on your steel constructions...
Your steel constructions will be **%30** cheaper...*





ADVANTAGES OF PEB SYSTEM



Cost: Peb system is rather economical in comparison to conventional systems. As agreements are made according to turn-key principle, it doesn't cause employers any unexpected costs. Cost reduction is not limited to steel constructions; infrastructure (foundation concrete, excavation etc.) costs are also reduced dramatically. No welding works are applied in the construction site. All joints are bolted. In case of any need, construction materials can be removed and used for other projects. This is a cost-reducing factor as especially the buildings which are used for a short period can be made use of in many other projects. Besides; as projects and relevant details are prepared by the producers, deducting design costs will also reduce the total cost amount.



Instant Installation: Installation period is very short as all products are bolted. This time reduction is a general cost-reducing factor for employers.



Recycling: Recycling duration of this investment is much shorter in comparison to other systems.



Strength and Safety: Sustainability of the buildings is ensured for long years without much maintenance need as all secondary steel elements are galvanized, primary elements are sandblasted and painted in the factory and all steel elements are prevented from being exposed to damp, condensation and corrosion thanks to the use of proper isolation systems.

In addition, the unnecessary steel elements used in conventional systems make buildings heavy. As is known, earthquakes' impacts on the buildings are directly proportionate to their masses. Earthquakes' impacts reduce at the same rate as buildings get lighter. At the same time, buildings' being unnecessarily heavy causes them to exceed ground bearing capacity.

As unnecessary heavy profiles are used in conventional systems, more stress concentrations occur on joints. No matter how heavy is the profile you are using, a building's safety is indexed to the success of the foreman welding under difficult conditions at the joints, on a ladder. In short, it is indexed to human factor. If any defect occurs in the welding applied to joints, the system may come to the brink of collapsing because of the junctures occurring in these areas.

In PEB system, all welding works are performed in the factory with robots and under the control of welding foremen. As buildings are light, the stress concentrations taking place on joints are reduced. Safety is not indexed to human factor any more since all joints are bolted.



Working Safety: Duration of the installation works performed on the construction site which is under employers' responsibility will be reduced, become practical and risk of work accidents will be minimized as 90% of the manufacturing period is completed in factories, all joints are bolted (not welded) and not even painting works are not performed on the construction site.



Low Maintenance and Operation Costs: Maintenance and operation costs of the buildings constructed with this system are rather low in comparison to other conventional buildings. Buildings maintain their new appearance for many years. They can even be removed and used in other projects.



Versatility and Architectural Design Flexibility: In PEB system, single storeys and mezzanines can be designed in the required roof type, session, space and height according to employers' needs.



Energy Saving: As the isolated materials and secondary steel elements used in buildings are designed to block air bridge, in summer hot air and in winter cold air are prevented from affecting buildings. At the same time, they don't allow moisture and damp formation in indoor area; prevent unnecessary energy consumption.



Longevity: You can be sure that you will have a building which will exist for long years thanks to high quality metals and joint elements.



Environment Friendly: 90% of the materials used in PEB system can be recycled.

USAGE AREAS OF PEB SYSTEM

Warehouses



Factories



Ateliers



Vehicle Park Shelters



Showrooms



Airport Hangars



Recreation Areas



Stadium Roofs



Outdoor Canopies



Offices



Petrol Stations



Subway Stations



Bridges



Schools



Stud-Barn



PEB systems are compatible with all architectural designs.

PEB CRITERIA

Design: The data obtained about PEB system throughout the world from the combination of science and engineering was reduced to systematic and special software was prepared. Thus, draft projects and cost estimations can be prepared free of charge in a short duration.

Cost estimations are prepared within three working days. In case of agreement, approval projects are prepared within 7-10 working days while whole projects are prepared within 15 working days. As offers are based on turnkey principle, the time required by employers for making recycling and cost calculations is quite reduced. Besides, employers don't need to allocate neither an employee nor any costs for this.

Basic Materials: High-strength S355 [St-52] steel materials are used in PEB systems.

Foundation: No turning effect is experienced in the foundations as foundation joints are hinged. So, solutions can be developed with much more economical foundation sizes.

Accessory: Such closing accessories as doors, windows etc. can be manufactured in various sizes according to relevant standards.

Delivery Period: Nearly 8-12 weeks

Installation: Installation works are performed in a short, simple, step-by-step and fast way according to the work schedule prepared based on the experience obtained from manufactured buildings.

Architectural: PEB system can be applied to all building types by using architectural expertization.

Cost: Its m² cost is 30 - 40% more economical in comparison to conventional steel and other buildings.

Coordination: When requested; linings, accessories and fitting materials as well as facing and roofing services are also offered. Thus, employers can make coordination more easily by working with a single contractor over a single cost.

Changes: Changes can be added to the system without increasing the cost a lot.

Responsibility: The whole responsibility is assumed by one contractor. So, the authorization chaos occurring when there is more than one contractor is eliminated.

Performance: All manufacturing components were designed to deliver accurate and efficient performance. As a result, the buildings constructed with their combination also deliver high performance.

PEB DESIGN

PEB Design Systems are based on rigidity matrix method and allowable stress design principles. Load combinations and specifications are left to user's wishes. All national and international design codes and standards can be used.

DESIGN CYCLE

Design cycle consists of the following steps

- 1- The loads in the preferred specification are entered to the system.
- 2- Axial force, shearing force and moment values are detected at all analyzed points for each load combination.
- 3- Shearing, axial and bending stress rates are compared with present and allowable stress values.
- 4- Optimum additional locations are designed and preferred sizes are checked to comply with manufacturing.
- 5- Joist depths appropriate to the cycle are reached by using the optimization mode of bodies and relevant data is renewed.

FRAME GEOMETRY

PEB system has the chance to solve different types of geometrical load-bearing systems as follows.

- Different type rigid frame, single or multiple span systems,
- Systems with different spans, different heights and different slopes
- Jointed, built-in, partial supported systems,
- Systems in different symmetric and asymmetric modules,
- Buildings constructed according to geometrical design determined by users,

PEB system can be used at up to 30-40m heights both in single-storey and multi-storey buildings. They can be applied at up to 80m in spans.

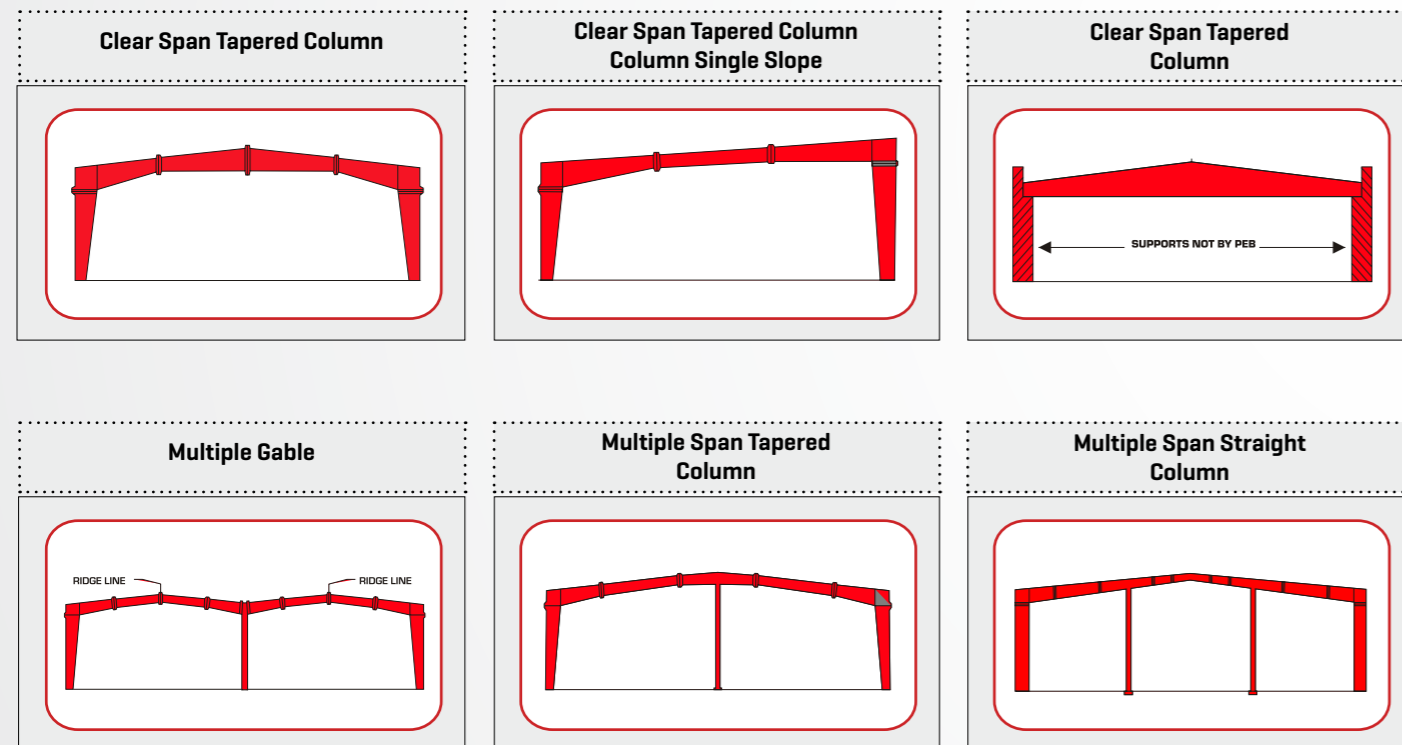

FRAME LOADS

In frame design, loads are handled as follows.

- All dead loads are adjusted to the system according to the self weight of frame elements.
- Desired moving loads are taken according to the codes used.
- Complementary loads; wind speed is also entered according to wind pressure units, preferred specification values are used according to users' wishes.
- Coefficient demand can be changed appropriately.
- Crane loads or non-crane loads can be defined by users. The program has also such features as special loading and combining other loads.
- Seismic loads and different zone categories can be defined according to different international codes. Required heat loads, heat differences and thermal expansion coefficients are applied according to users' wishes.

DESIGN CODES AND STANDARDS

Design Codes

- TDY Turkish Earthquake Regulation - TR Ministry of Public Works and Settlement
- MSC Manual Steel Cons. - American Institute of Steel Construction, Inc. [AISC]
- CFSD Cold Formed Steel Design Manual - American Iron and Steel Institute [AISI]
- AWCSM American Welding Code Steel Manual - American Welding Society [AWS]

Standards

- UBC Uniform Building Code - International Building Code, Inc. [IBC]

- MBSM Metal Building Systems Manual - Metal Building Manufacturers Association, Inc. [MBMA]
- TS498 Sizes of Construction Elements, Calculation Values of the Loads to be taken - Turkish Standards Institute [TSE]
- TS648 Calculation and Building Rules for Steel Constructions - - Turkish Standards Institute [TSE]

DESIGN PROCESSES

Frame data is combined according to the number of frames, connection points, freedom degrees, limitations and elastic characteristics. This way, data is stored and elements sections are calculated.

All rigidity matrixes based on frame data which takes into account all possible deflections are obtained. Load vector is obtained by summing up multiplied load vector, all reversible rigidity matrixes and unknown displacements.

PEB COMPONENTS

There are 3 types of construction elements in PEB systems.

- Primary Steel [Built Up Sections]
- Secondary Steel [Secondary Members]
- Accessories [Accessories, Flashing and Trims]

PRIMARY STEEL ELEMENTS (BUILT UP SECTIONS)

They consist of three construction elements; variable frame, stability connections and flange supports. Stability and flange supports are the elements helping frame design.



a-) Variable Frame

In PEB systems, sections vary according to the statuses of stress concentrations while steel frames, columns and joists follow only one section in conventional systems. Variable frames consist of joists and columns. Rigid frame is the main bearer of building system.



b-) Stability Connections

Profiles, rods and cables are generally used for this purpose according to span, height, axis number, wind and earthquake loads. They enable the transfer of horizontal forces to ground level as well as enabling load transfer. They maintain general stability of buildings.



c-) Flange Supports

Flange supports are beneficial elements which support flanges of the profiles they are attached to and at the same time reduce bearing distance by helping moment transfer of the purlins. Corner profiles are usually preferred. They are used as double-sided on ridge and barge parts of frames while being used as one-sided on other parts.

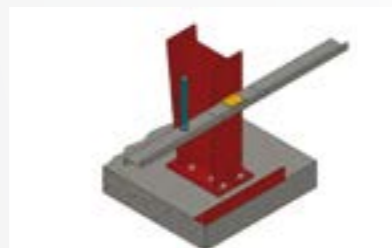

SECONDARY STEEL ELEMENTS [SECONDARY MEMBERS]

Secondary steels are the supporting elements which support roof and wall lining connections as well helping to transfer loads to the primary steel. Secondary steels are rather used in purlins, face bands and barges. The mill profiles used in these areas in conventional systems are heavy but their inertia values are low.

Their bearing capacities are not so high although heavy and costly mill profiles are used. Z or C profiles manufactured with cold form in required sizes and strength levels by using galvanized sheets which have high yield strength and comply with ST 52 standard are used in PEB system. These profiles are both economical and have a higher bearing capacity.

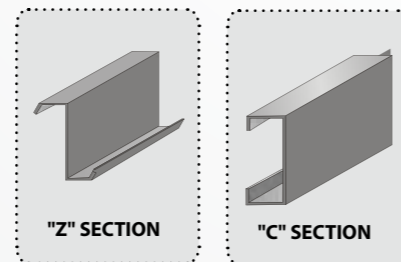

Some Examples for Secondary Steel Members



a-) Purlins

They are usually design as Z section in cold form. Their depths vary between 200-250 mm while wall thicknesses vary between 1.5 and 3mm. Purlins are fixed to the upper flanges of variable section frames with clips.



b-) Face Bands

They are usually design as Z, C or Omega sections in cold form. Their depths vary between 200-250mm while wall thicknesses vary between 1.5 and 3mm. Bands are fixed to the exterior flanges of variable section frames' exterior columns with clips.

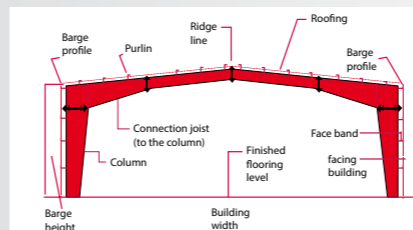

c-) Barge Profile

They are usually designed as Z or C sections in cold form. Their depths vary between 200-250mm while wall thicknesses vary between 1.5 and 3mm. Bands are fixed to the exterior flanges of variable section frames' exterior columns with clips.



d-) Wind Columns

They help to reduce span and deflection values by supporting face bands against the wind loads to come front and back faces.



ACCESSORIES (ACCESSORIES, FLASHINGS AND TRIMS)

These are the profiles manufactured with cold bending which are used to help facing and roofing installations, heat and water isolation as well as the prevention of heat bridge constitutions. They are used in internal-external closings, hood molds, windows, doors, all endings and many interior places.

Accessory elements are usually examined in four groups:

- a-) Gutter and decline accessories,
- b-) Corner flashings
- c-) Ridge accessories,
- d-) Door-window accessories

SOME EXAMPLES

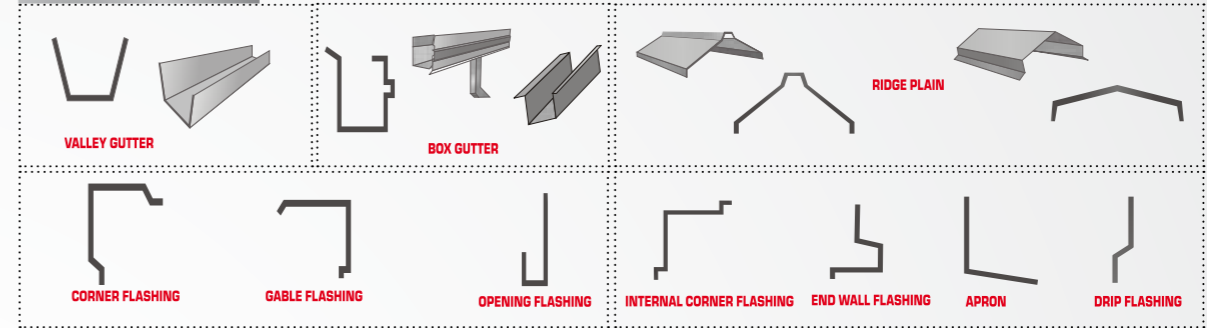

MEZZANINE FLOORS

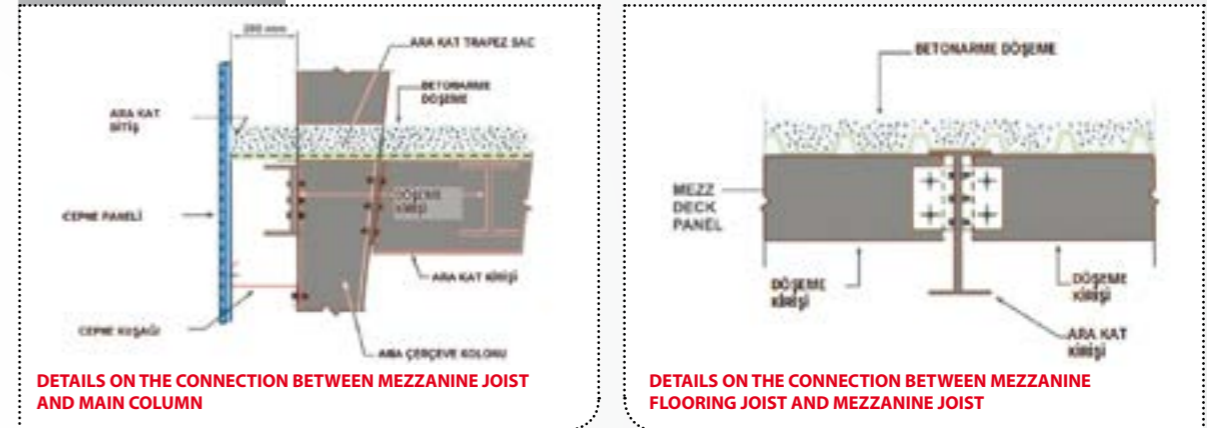

In PEB systems, mezzanines are also built according to above details. Mezzanines may be single floors within the building or they can be in parts. Mezzanine elements are trapeze sheet, flooring, floor joist profiles and concrete. Multi-staged equipment platforms, catwalks and staircases can be adapted to the project.

CRANE BUILDINGS



PEB system can be designed easily in all crane buildings.

HIGH-RISE BUILDINGS



Offering architectural freedom with its lightness, formability and wide span crossing features, PEB can be applied to high-rise industrial buildings and all house-type buildings.

BARGE GUTTER INSTALLATION

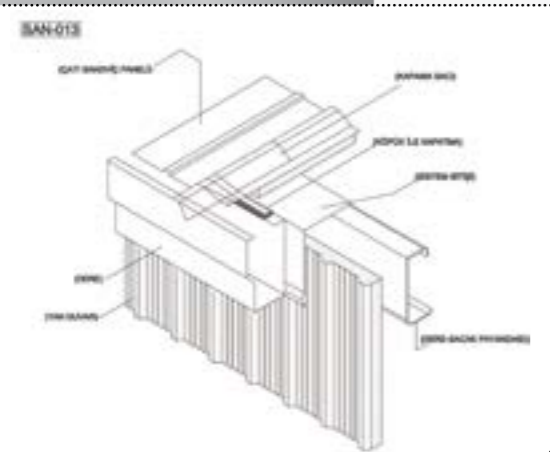

FRAME CROSS

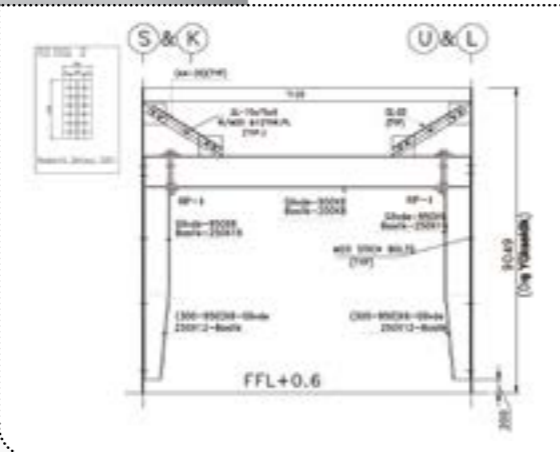

FOUNDATION DETAILS (PARTIAL WALL)

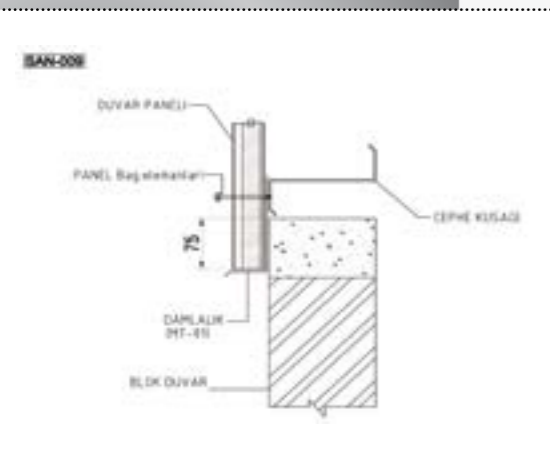

WALL PANEL DETAIL (ISO APPEARANCE)

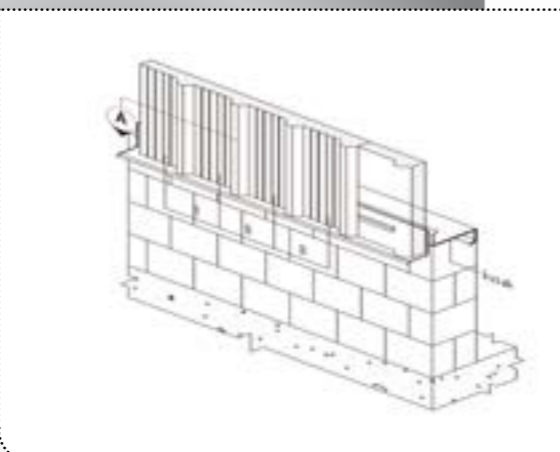



EXAMPLES FOR MILL AND COLD PROFILE BEARING CAPACITIES

Safe design is only possible by designing in accordance with engineering rules not by making buildings heavier.

Z SECTION

Z20 Section Features [Safety Stress for ST52 Steel: 2, 16 t/cm²
W_x=47,55 cm³

G=5,90 kg/m

M_{max}=σ_{em} x W_x = [2,16 t/cm²][47,55 cm³]=102,71 tcm

UPE140

Safety Stress for ST37 Steel: 1, 44 t/cm²

W_x=85,64 cm³

G=14,5 kg/m

M_{max}=σ_{em} x W_x = [1,44 t/cm²][85,64 cm³]=123,3 tcm

Weight differences between a mill profile and a cold form profile used to carry a moment of 100tcm.

UPE 140 =14.5 kg/ Z20=5.90 kg difference=2.46 folds

Example 2

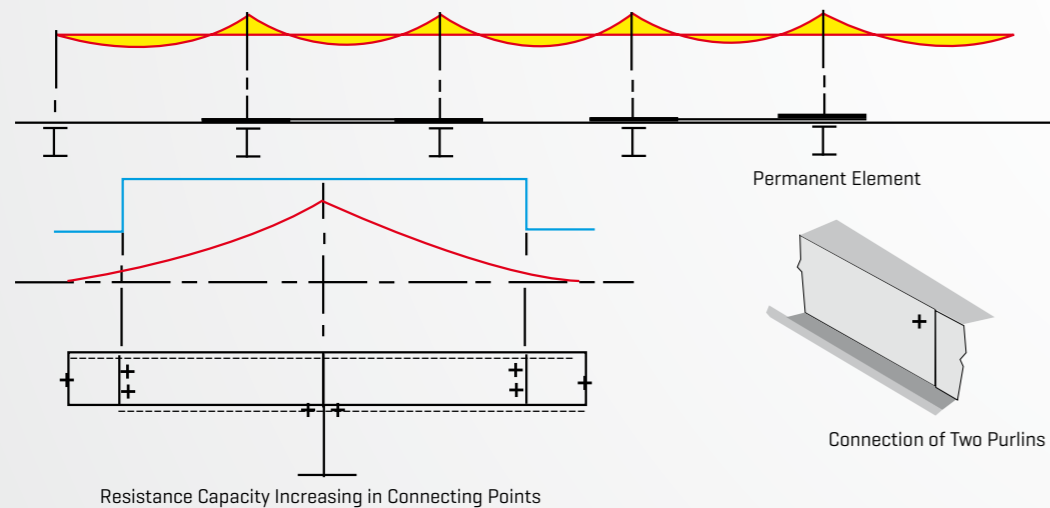

As is seen in the figure; Z profiles are tucked in each other on locations where additional parts fall onto frames. They are connected with bolts and fixed on the frame with their clips. Braces are made more rigid by using flange supports; they are enabled to receive moment. Continuity is maintained, moment values of the middle area which is the most unfavorable section are reduced to more reasonable limits.

CONSTRUCTION COMPONENTS IN PEB SYSTEM

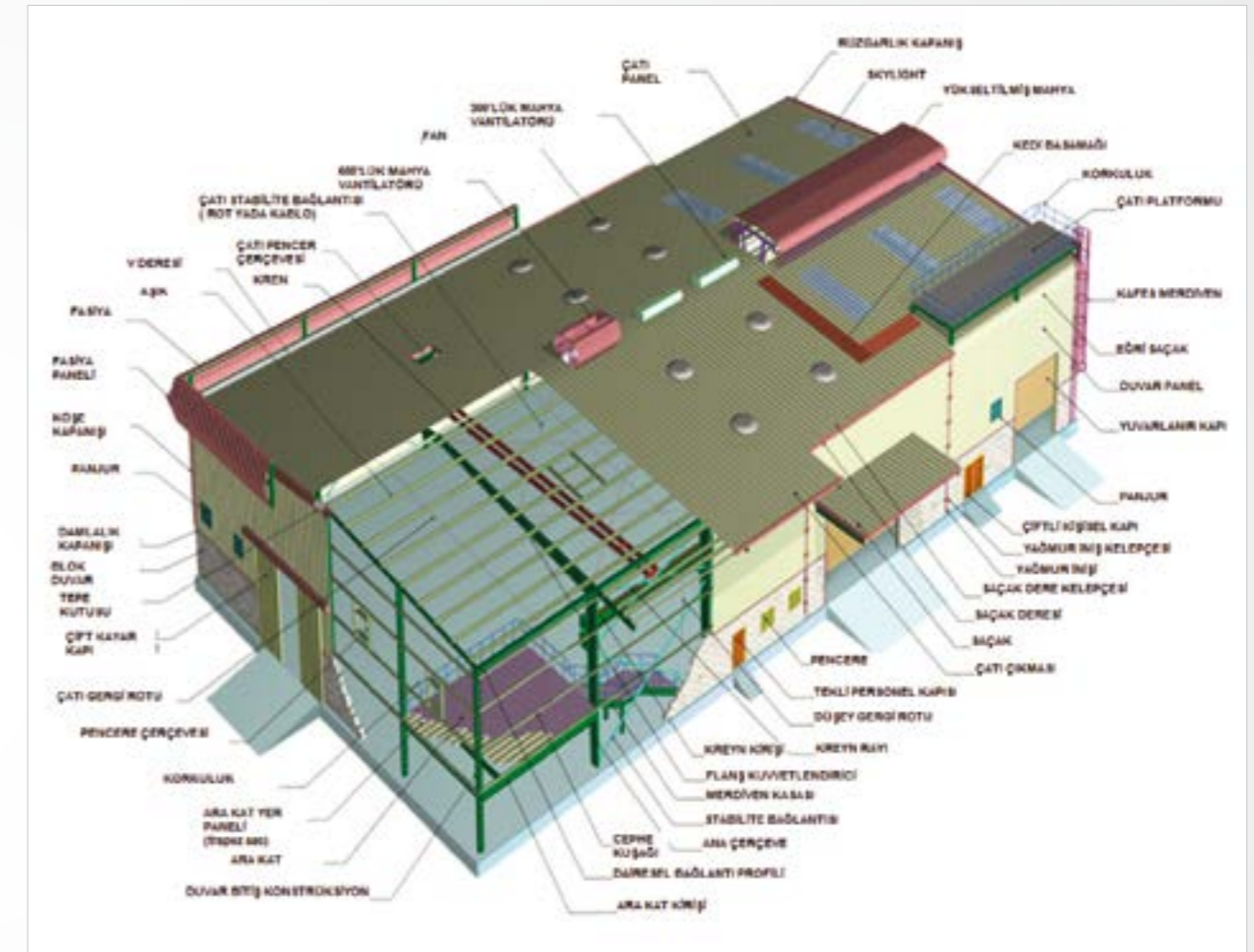

In our country, steel which is one of our biggest import items is consumed so much by still applying classical engineering rules without bothering to perform R&D activities while it is consumed economically in all developed countries of the world by applying engineering methods. This situation causes high costs for the investors.

- Stopping unnecessary steel use thanks to more economical solutions,
- Getting the worth of investments in very short periods,
- Reducing business costs,
- Having a safer building against earthquakes,

These are all possible now.





TOLAY STEEL
CONSTRUCTION AND PEB SYSTEM

Giyimkent 16. Sokak No: 54 Esenler - ISTANBUL
Phone: +90 212 351 12 40 Fax: +90 212 351 12 35
www.tolay.com.tr · info@tolay.com.tr