

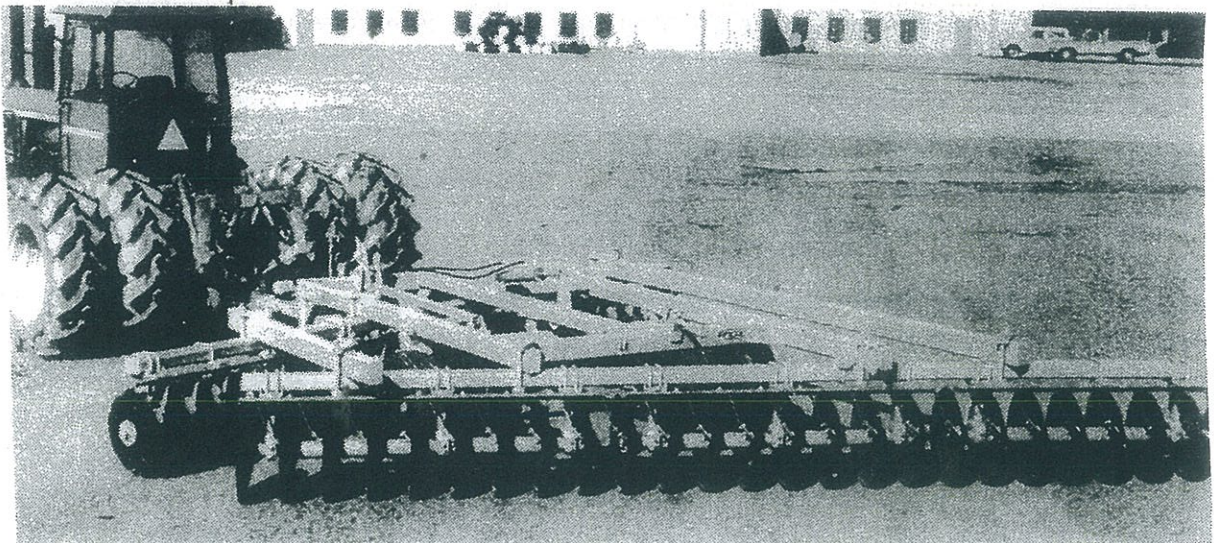

**F42\*\*J42\*\*J43\*\*J44**

**OPERATION\*\*MAINTENANCE\*\*SET-UP  
INSTRUCTIONS**



**AMCO MANUFACTURING COMPANY**

800 South Industrial Parkway P.O. Box 1107  
Yazoo City, Mississippi (MS) 39194 USA  
(662) 746-4464 Toll free 800-748-9022 Fax (662) 746-6825

## TO THE PURCHASER

The care you give you new AMCO Offset Disk Harrow will greatly determine the satisfaction and service you will obtain from it. By observing the instructions and suggestions in this manual, your AMCO Offset Harrow will serve you well for many years.

As an Authorized Dealer, we stock Genuine AMCO Parts, which are manufactured with the same precision and skill as the original equipment. For best performance and longer life use only Genuine AMCO replacement parts. Our factory trained staff is kept fully informed of the most efficient methods of servicing AMCO equipment and is ready and able to assist you.

When you sell your Harrow you should pass this manual to the new owner.

If you should require additional aid or information, contact us.

YOUR AUTHORIZED AMCO DEALER

OSHA requires that as a farm employer you meet certain safety requirements. Become familiar with and comply with those requirements. Be sure anyone who operates this equipment understands all safety related items. If this harrow is repainted, be certain new decals are ordered. Decals pertaining to personal safety must be replaced.



Look for this symbol to point out important safety precautions. It means — ATTENTION! Become alert! Your safety is involved.

To insure efficient and prompt service, please provide the model number and serial number of your AMCO Harrow in all correspondence or contacts. Remember, the right and left hand sides of the harrow are determined by standing at the rear of the harrow and facing the direction of travel.

MODEL NUMBER

SERIAL NUMBER

## Table of Contents

To the Purchaser	i
Table of Contents	1
Safety Suggestions	2
General Specifications	
F42	3
J42	4
J43	5
J44	6
Torque Specifications Table	7

## Parts List

Pull Tongue	9
50" Main Frame & Rockshaft	11
86" Main Frame & Rockshaft	13
Spindle & Hub	14
Spindle & Hub Insert	15
Auxiliary Frame	16
4 x 8 Hydraulic Cylinder	17
4 x 16 Hydraulic Cylinder	18
Spindle & Hub	19
F42 Front Gang & Frame	21
F42 Rear Gang & Frame	23
J42 Front Gang & Frame	25
J42 Rear Gang & Frame	27
J43 Front Gang & Frame	29
J43 Rear Gang & Frame	31
J44 Front Gang & Frame	33
J44 Rear Gang & Frame	35
J42**J43*J44 Feathering Blades	36
J43 Shock Absorber Bearing Riser	37
J44 Shock Absorber Bearing Riser	38
Decals	39

## Operators Manual

Assembly Instructions	40
Lubrication	42
Operating Instructions	43
Maintenance	48
Operating Tips	51
Gang Placement Chart	52
Disk Blade Failure	55

Rev. 3/12



**THIS SAFETY ALERT SYMBOL INDICATES IMPORTANT SAFETY MESSAGES IN THIS MANUAL. WHEN YOU SEE THIS SYMBOL, CAREFULLY READ THE MESSAGE THAT FOLLOWS AND BE ALERT TO THE POSSIBILITY OF PERSONAL INJURY.**



**CAUTION!** Never stand between tractor and disk harrow when hitching unless all controls are in neutral and the brakes are locked.



**CAUTION!** Park or block the disk harrow so it will not roll when disconnected from the tractor drawbar.



**CAUTION!** When working on disk harrows, care should be exercised in handling or tightening bolts near disk blades to avoid injury.



**CAUTION!** Always secure for transport by using the lock pin and wing lock pins.



**CAUTION!** Never clean, adjust or lubricate a disk harrow that is in motion.



**CAUTION!** Stay out from underneath wing gangs when folding or unfolding.



**CAUTION!** When transporting machinery over public roads, comply with your local and state laws regarding length, width and lighting.



**CAUTION!** When trailing the harrow over public roads, the SMV Emblem must be used for protection of tractor and motor vehicle operators.



**CAUTION!** When transporting farm implements on public roads after dusk, it is the responsibility of the operator to provide lighting and reflectors on the rear of the implement in accordance with your state law.



**CAUTION!** All hydraulically or mechanically elevated operating components must be blocked to prevent accidental lowering or must be lowered to the ground when making adjustments or when the equipment is idle.

**F42 WHEEL OFFSET HARROW 8'3" - 18'0"**  
**STANDARD SPECIFICATIONS (Metrics in Parenthesis)**

<b>AXLES:</b>	1-1/2" (38mm) square, high carbon cold rolled steel.	<b>SPACING:</b>	9 inches (229mm).
<b>BLADES:</b>	24" x 1/4" (610mm x 6.5mm) Plain with diminishing leveling blades. Back-up disc behind right front blade.	<b>WHEELS:</b>	Dual 15" x 8" with 6-bolt hubs.
<b>SCRAPERS:</b>	Heavy duty high carbon steel blades on 3/8" x 2" (10mm x 51mm) spring steel shanks mounted on 3" x 2" x 3/8" (76mm x 51mm x 9.5mm) angle iron scraper bar.	<b>WRENCHES:</b>	2 for gang bolts.
<b>TONGUE:</b>	Adjustable, 88-1/2" (2.25m) long with tongue jack and reversible ductile iron clevis.	<b>WEIGHT:</b>	164 to 197 lbs. per blade (74 to 89 kg. per blade). 439 to 525 lbs. per foot (60 to 73 kg. per meter).
<b>GANG ANGLE:</b>	17° to 25° front to rear.	<b>TRANSPORT WIDTH:</b>	Cutting width plus 12" (0.30m) plus additional 12" (0.30m) with feathering blades.
<b>BEARINGS:</b>	Protect-O-Shield heavy duty 1-1/2" (38mm) square bore greasable ball type, toggle mounted.	<b>HYDRAULIC CYLINDERS:</b>	4" x 8" x 1-1/2" with stroke control on 50" (1.27m) main frame. 4" x 16" x 2" on 86" (2.18m) main frames.

Model	Cutting Width	No. of Discs	No. of Bearings	Approx. D.B.H.P. Required		Approx. Weight	
				HP	[KW]	Lbs.	[Kg.]
<b>50" [1.27m] MAIN FRAME</b>							
F42-2224-PB	8'3" (2.51m)	22	8	70-90	(52-67)	4038	(1835)
F42-2424-PB	9'0" (2.74m)	24	8	80-105	(60-78)	4182	(1901)
F42-2824-PB	10'6" (3.20m)	28	8	90-120	(67-89)	4677	(2126)
F42-3224-PB	12'0" (3.66m)	32	10	100-140	(75-104)	5115	(2325)
<b>86" [2.18m] MAIN FRAME</b>							
F42B-3224-PB	12'0" (3.66m)	32	10	110-150	(82-112)	6316	(2871)
F42-3624-PB	13'6" (4.11m)	36	12	120-160	(89-119)	6600	(3000)
F42-4024-PB	15'0" (4.57m)	40	12	135-175	(101-130)	6900	(3136)
*F42-4424-PB	16'6" (5.03m)	44	14	150-190	(112-142)	7917	(3599)
*F42-4824-PB	18'0" (5.49m)	48	16	165-205	(123-153)	8201	(3728)

**\*EQUIPPED WITH AUXILIARY FRAMES & CLAMPS**

**OPTIONAL EQUIPMENT**

- Feathering blade with scraper for rear gang.
- Hose set with one 1/2" x 15' (13mm x 4.57m) and one 1/2" x 16' (13mm x 4.88m) hose.
- Single wheels in lieu of duals [50" (1.27m) Main Frame].
- 15" x 10" wheels in lieu of 15" x 8" wheels
- Gang Drivers (Set of One)
- 24" x 1/4" (610mm x 6.5mm) cutout blades in lieu of std. 24" (610mm)
- Shock absorber bearing riser with 1-1/4" x 2-1/2" (32mm x 64mm) spring steel shank.
- Safety Chain.

**RECOMMENDED TIRE SIZE**

- 9.5L x 15", 6-Ply or 8-Ply
- 11L x 15", 6-Ply or 8-Ply

**NOTE:**

Use of disk on tractors with higher than recommended drawbar horsepower will cause excessive maintenance cost and may void your warranty.

**J42 WHEEL OFFSET HARROW 8'8" - 18'8"**  
**STANDARD SPECIFICATIONS (Metrics in Parenthesis)**

<b>AXLES:</b>	1-1/2" (38mm) square, high carbon cold rolled steel.	<b>SPACING:</b>	10-1/2 inches (267mm)
<b>hubs.BLADES:</b>	24" x 1/4" (610mm x 6.5mm) Plain with diminishing leveling blades. Back-up disc behind right front blade.	<b>WHEELS:</b>	Dual 15" x 8" with 6-bolt
<b>SCRAPERS:</b>	Heavy duty high carbon steel blades on 3/8" x 2" (10mm x 51mm) spring steel shanks mounted on 3" x 2" x 3/8" (76mm x 51mm x 9.5mm) angle iron scraper bar	<b>WRENCHES:</b>	2 for gang bolts.
<b>TONGUE:</b>	Adjustable, 88-1/2" (2.25m) long with tongue jack and reversible ductile iron clevis.	<b>WEIGHT:</b>	179 to 208 lbs. per blade (81 to 94 kg. per blade), 422 to 480 lbs. per foot (58 to 66 kg. per meter)
<b>GANG ANGLE:</b>	17° to 25° front to rear	<b>TRANSPORT WIDTH:</b>	Cutting width plus 12" (0.30m) plus additional 12" (0.30m) with feathering blades.
<b>BEARINGS:</b>	Protect-O-Shield heavy duty 1-1/2" (38mm) square bore greasable ball type, toggle mounted.	<b>HYDRAULIC CYLINDERS:</b>	4" x 8" x 1-1/2" with stroke control on 50" (1.27m) main frame. 4" x 16" x 2 on 86" (2.18m) main frame.

Model	Cutting Width	No. of Discs	No. of Bearings	Approx. D.B.H.P. Required		Approx. Weight	
				H.P.	[Kw.]	Lbs.	[Kg.]
<b>50" [1.27m] MAIN FRAME</b>							
J42-2024-PB	8'8" (2.64m)	20	6	75-95	(56-71)	3829	(1740)
J42-2424-PB	10'4" (3.15m)	24	8	90-120	(67-89)	4506	(2048)
J42-2824-PB	12'0" (3.66m)	28	10	100-130	(75-97)	4929	(2240)
<b>86" [1.27m] MAIN FRAME</b>							
J42B-2824-PB	12'0" (3.66m)	28	10	110-140	(82-104)	5955	(2707)
J42-3224-PB	13'8" (4.17m)	32	12	125-150	(93-112)	6450	(2932)
J42-3624-PB	15'4" (4.67m)	36	12	140-175	(104-130)	6802	(3092)
*J42-4024-PB	17'0" (5.18m)	40	12	160-190	(119-142)	7663	(3483)
*J42-4424-PB	18'8" (5.69m)	44	16	175-205	(130-153)	8249	(3750)
*J42-4824-PB	20'0" (6.00m)	48	16	185-225	(138-168)	8601	(3910)

**\*EQUIPPED WITH AUXILIARY FRAMES & CLAMPS**

**OPTIONAL EQUIPMENT**

Feathering blade with scraper for rear gang.  
Hose set with one 1/2" x 15' (13mm x 4.57m) and one 1/2" x 16' (13mm x 4.88m) hose.  
Single wheels in lieu of duals [50" (1.27m) Main Frame].  
15" x 10" wheels in lieu of 15" x 8" wheels.  
Gang Drivers (Set of One).  
24" x 1/4" (610mm x 6.5mm) cutout blades in lieu of Std. 24" (610mm).  
26" x 1/4" (660mm x 6.5mm) plain blades in lieu of Std. 24" (610mm).  
26" x 1/4" (660mm x 6.5mm) cutout blades in lieu of Std. 24" (610mm).  
Shock absorber bearing riser with 1-1/4" x 2-1/2" (32mm x 64mm) spring steel shank.  
Safety Chain.

**RECOMMENDED TIRE SIZE**

9.5L x 15", 6-Ply or  
11L x 15", 6-Ply

**NOTE:**

Use of disk on tractors with higher than recommended drawbar horsepower will cause excessive maintenance cost and may void your warranty.

**J43 WHEEL OFFSET HARROW 8'8" - 18'8"**  
**STANDARD SPECIFICATIONS (Metrics in Parenthesis)**

<b>AXLES:</b>	1-1/2" (38mm) square, high carbon cold rolled steel.	<b>BEARINGS:</b>	Protect-O-Shield, extra heavy duty 2-1 1/16" (68mm) bore greasable ball type, toggle mounted.
<b>BLADES:</b>	24" x 1/4" (610 mm x 6.5mm) Plain with diminishing leveling blades. Back up disc behind right front blade.	<b>SPACING:</b>	10-1/2 inches (267 mm).
<b>SCRAPERS:</b>	Heavy duty high carbon steel blades on 3/8" x 2" (10mm x 51mm) spring steel shanks mounted on 3" x 2" x 3/8" (76 mm x 51mm x 9.5mm) angle iron scraper bar.	<b>WHEELS:</b>	Dual 15" x 8" with 6-bolt hubs.
<b>TONGUE:</b>	Adjustable, 88-1/2" (2.25m) long with tongue jack and reversible ductile iron clevis.	<b>WRENCHES:</b>	2 for gang bolts.
<b>GANG ANGLE:</b>	17° to 25° front to rear.	<b>WEIGHT:</b>	205 to 231 lbs. per blade (93 to 105 kg. per blade), 483 to 533 lbs. per foot (67 to 74 kg. per meter).
<b>BEARING RISER:</b>	Spring steel shock absorber shank — 1-1/4" x 2-1/2" (32mm x 64mm).	<b>TRANSPORT WIDTH:</b>	Cutting width plus 12" (0.30m) plus additional 12" (0.30m) with feathering blades
		<b>HYDRAULIC CYLINDERS:</b>	4" x 8" x 1-1/2" with stroke control on 50" (1.27m) main frame. 4" x 16" x 2" on 86" (2.18m) main frame.

Model	Cutting Width	No. of Discs	No. Of Bearings	Approximate D.B.H.P. Required		Approximate Weight	
				H.P.	[Kw]	Lbs.	[Kg]
<b>50" [1.27m] MAIN FRAME</b>							
J43-2024 PB	8'8" (2.64m)	20	6	85-100	(63-75)	4195	(1907)
J43-2424 PB	10'4" (3.15m)	24	8	90-120	(67-89)	4928	(2240)
J43-2824 PB	12'0" (3.66m)	28	10	110-140	(82-104)	5509	(2504)
<b>86" [2.18] MAIN FRAME</b>							
J43B-2824 PB	12'0" (3.66m)	28	10	120-150	(87-112)	6508	(2958)
J43-3224 PB	13'8" (4.17m)	32	12	130-170	(97-127)	7105	(3230)
J43-3624 PB	15'4" (4.67m)	36	12	140-180	(104-134)	7934	(3629)
*J43-4024 PB	17'0" (5.18m)	40	12	160-200	(119-149)	8393	(3815)
*J43-4424 PB	18'8" (5.69m)	44	16	180-225	(134-168)	9143	(4156)

**\*EQUIPPED WITH AUXILIARY FRAMES & CLAMPS**

**OPTIONAL EQUIPMENT**

- Feathering blade with scraper for rear gang
- Hose set with one 1/2" x 15' (13mm x 4.57m) and one 1/2" x 16' (13mm x 4.88) hose
- Single wheels in lieu of Duals [50" (1.27m) Main Frame]
- 15" x 10" wheels in lieu of 15" x 8" wheels
- Gang Drivers (Set of One)
- 24" x 1/4" (610 mm x 6.5mm) cutout blades in lieu of std. 24" (610mm)
- 26" x 1/4" (660mm x 6.5mm) plain blades in lieu of std. 24" (610mm)
- 26" x 1/4" (660mm x 6.5mm) cutout blades in lieu of std. 24" (610mm)
- 26" x 5/16" (660mm x 8mm) plain blades in lieu of std. 24" (610mm)
- 26" x 5/16" (660mm x 8mm) cutout blades in lieu of std. 24" (610mm)
- Safety Chain

**RECOMMENDED TIRE SIZE**

- 9.5L x 15", 6-Ply or 11L x 15", 6-Ply
- (4) 9.5L x 15", 8-Ply or
- (4) 11L x 15", 8-Ply for 17'0" and 18'8" only.

**NOTE:**

Use of disk on tractors with higher than recommended drawbar horsepower will cause excessive maintenance cost and may void your warranty.

**J44 WHEEL OFFSET HARROW 8'8" - 18'8"**  
**STANDARD SPECIFICATIONS (Metrics in Parenthesis)**

<b>AXLES:</b>	1-1/2" (38mm) square, high carbon cold rolled steel.	<b>BEARINGS:</b>	Protecto-O-Shield, extra heavy duty 2-11/16" (68mm) bore greasable ball type, toggle ball type, toggle mounted.
<b>BLADES:</b>	24" x 1/4" (610mm x 6.5mm) Plain with diminishing leveling blades. Back up discs behind every front blade.	<b>SPACING:</b>	10-1/2" inches (267mm).
<b>SCRAPERS:</b>	Heavy duty high carbon steel blades on 3/8" x 2-1/2" (10mm x 51mm) spring steel shanks mounted on scraper bars of 2-1/2" x 2-1/2" x 1/4" (64mm x 64mm x 6.4mm) structural tube.	<b>WHEELS:</b>	Dual 15" x 8" with 6-bolt hubs.
<b>TONGUE:</b>	Adjustable, 88-1/2" (2.25m) long with tongue jack and reversible ductile iron clevis.	<b>WRENCHES:</b>	2 for gang bolts.
<b>GANG ANGLE:</b>	17° to 25° front and rear.	<b>WEIGHT:</b>	210 to 237 lbs. per blade (95 to 108 kg. per blade), 495 to 546 lbs. per foot (68 to 74 kg. per meter).
<b>BEARING RISER:</b>	Spring steel shock absorber shank-- 1-1/4" x 2-1/2" (32mm x 64mm).	<b>TRANSPORT WIDTH:</b>	Cutting width plus 12" (0.30m) plus additional 12" (0.30m) with feathering blades.
		<b>HYDRAULIC CYLINDERS:</b>	4" x 8" x 1-1/2" with stroke control on 50" (1.27m) main frame. 4" x 16" x 2" on 86" (2.18m) main frame.

Model	Cutting Width	No. of Discs	No. of Bearings	Approx. D.B.H.P. Required		Approx. Weight	
				H.P.	[Kw.]	Lbs.	[Kg.]
<b>50" [1.27m] MAIN FRAME</b>							
J44-2024-PB	8'8" (2.64m)	20	6	95-120	(71-90)	4356	(1980)
J44-2424-PB	10'4" (3.15m)	24	8	110-130	(82-97)	5114	(2325)
<b>86" [2.18m] MAIN FRAME</b>							
J44-2824-PB	12'0" (3.66m)	28	10	120-160	(89-119)	6740	(3064)
J44-3224-PB	13'8" (4.17m)	32	12	130-170	(97-127)	7359	(3345)
J44-3624-PB	15'4" (4.67m)	36	12	140-180	(104-134)	8266	(3757)
*J44-4024-PB	17'0" (5.18m)	40	16	160-200	(119-149)	9081	(4127)
*J44-4424-PB	18'8" (5.69m)	44	16	180-225	(134-168)	9486	(4312)

**\*EQUIPPED WITH AUXILIARY FRAMES & CLAMPS**

**OPTIONAL EQUIPMENT**

Hose set with one 1/2" x 15' (13mm x 4.57m) and one 1/2" x 16' (13mm x 4.88m) hose.

Feathering blade with scraper for rear gang.

Single wheels in lieu of duals [50" (1.27m) Main Frame] Less back-up blades.

15" x 10" wheels in lieu of 15" x 8" wheels

Gang Drivers (Set of One)

24" x 1/4" (610mm x 6.5mm) cutout blades in lieu of Std. 24" (610mm)

26" x 1/4" (660mm x 6.5mm) plain blades in lieu of Std. 24" (610mm)

26" x 1/4" (660mm x 6.5mm) cutout blades in lieu of Std. 24" (610mm)

26" x 5/16" (660mm x 8mm) plain blades in lieu of Std. 24" (610mm)

26" x 5/16" (660mm x 8mm) cutout blades in lieu of Std. 24" (610mm)

Safety Chain

**RECOMMENDED TIRE SIZE**

9.5L x 15", 6-Ply or

11L x 15", 6-Ply

4 - 9.5L x 15, 8-Ply or

4 - 11L x 15, 8-Ply for all

Models 15'4" and larger.







**NOTE:**

Use of disk on tractors with higher than recommended drawbar horsepower will cause excessive maintenance cost and may void your warranty.



# GENERAL TORQUE SPECIFICATION TABLE

ALL BOLTS SHOULD BE TIGHTENED TO THE  
RECOMMENDED TORQUES SHOWN IN THE  
"GENERAL TORQUE SPECIFICATION TABLE"

<b>GENERAL TORQUE SPECIFICATION TABLE</b>							
USE THE FOLLOWING TORQUES WHEN SPECIAL TORQUES ARE NOT GIVEN							
<p><b>Note:</b> These values apply to fasteners as received from supplier, dry, or when lubricated with normal engine oil. They do not apply if special graphited or moly-disulphide greases or other extreme pressure lubricants are used. This applies to both UNF and UNC threads.</p>							
SAE Grade No.		2		5		8 *	
Bolt head identification marks as per grade NOTE: Manufacturing Marks Will Vary				  		  	
		Torque		Torque		Torque	
Bolt Size		Foot Pounds		Foot Pounds		Foot Pounds	
Inches	Millimeters	Min.	Max.	Min	Max	Min	Max.
1/4	6.35	5	6	9	11	12	15
5/16	7.94	10	12	17	20.5	24	29
3/8	9.53	20	23	35	42	45	54
7/16	11.11	30	35	54	64	70	84
1/2	12.70	45	52	80	96	110	132
9/16	14.29	65	75	110	132	160	192
5/8	15.88	95	105	150	180	220	264
3/4	19.05	150	185	270	324	380	456
7/8	22.23	160	200	400	480	600	720
1	25.40	250	300	580	696	900	1080
1-1/8	25.58			800	880	1280	1440
1-1/4	31.75			1120	1240	1820	2000
1-3/8	34.93			1460	1680	2380	2720
1-1/2	38.10			1940	2200	3160	3560

\* Thick nuts must be used with Grade 8 bolts

# PULL TONGUE

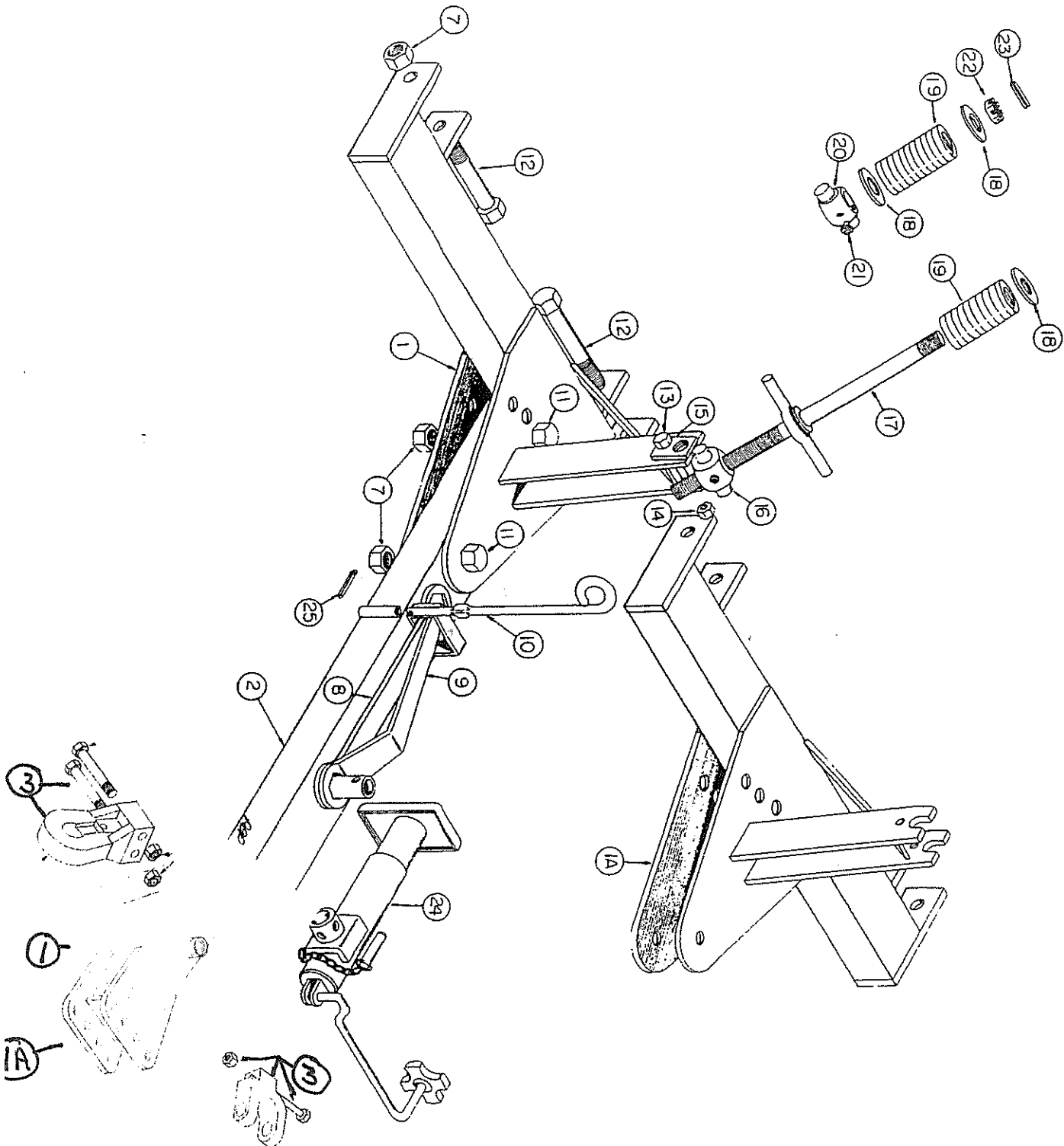

NOTE: ABOVE DRAWING DOES NOT SHOW NEW SAFETY CHAIN ATTACHMENT

<b>AMCO</b>			
<b>F42** J42** J43** J44 SERIES</b>			
<b>DISK HARROW PULL TONGUE</b>			
<u>Ref. No.</u>	<u>Part No.</u>	<u>Description</u>	<u>No. Req'd.</u>
1	20038	Cross Tongue (for 50" Main Frames)	1
1A	20031	Cross Tongue (for 86" Main Frames)	1
2	20655	Pull Tongue	1
3	12453	Clevis - With 12456 Clevis	1
	10304	1 x 6 -1/2 NC, PLT, Hex Bolt Gr. 5	2
	10868	1" NC, PLT Lock Nut	2
7	10397	Lock Nut - 1-1/4" NC, PL	4
8	100136	Nut Wrench (fits Hex Nut 1-3/8" & 1-1/2")	1
9	100134	Nut Wrench (fits Hex Nut 1-1/2")	1
10	100061	Hose Holder	1
11	10867	Hex Bolt - 1-1/4" x 6-1/2" NC, PL	2
12	11037	Hex Bolt - 1-1/4" x 8" NC, PL	2
13	10067	Hex Bolt - 5/8" x 5-1/2" NC, PL	1
14	10299	Lock Nut - 5/8" NC, PL	1
15	9628	Trunnion Clamp	2
16	9919A	Stabilizer Swivel	1
17	20108	Stabilizer Rod	1
18	10872	Cut Washer 1-3/8" PL	3
19	10460A	Spring	2
20	9892	Swivel	1
21	10606	Grease Fitting 1/8" NPT Threaded	2
22	11279	Slotted Hex Nut - 1-3/8" NC	1
23	10910	Roll Pin	1
24	11261	Parking Jack	1
25	10075	Cotter Pin	1

50" MAIN FRAME

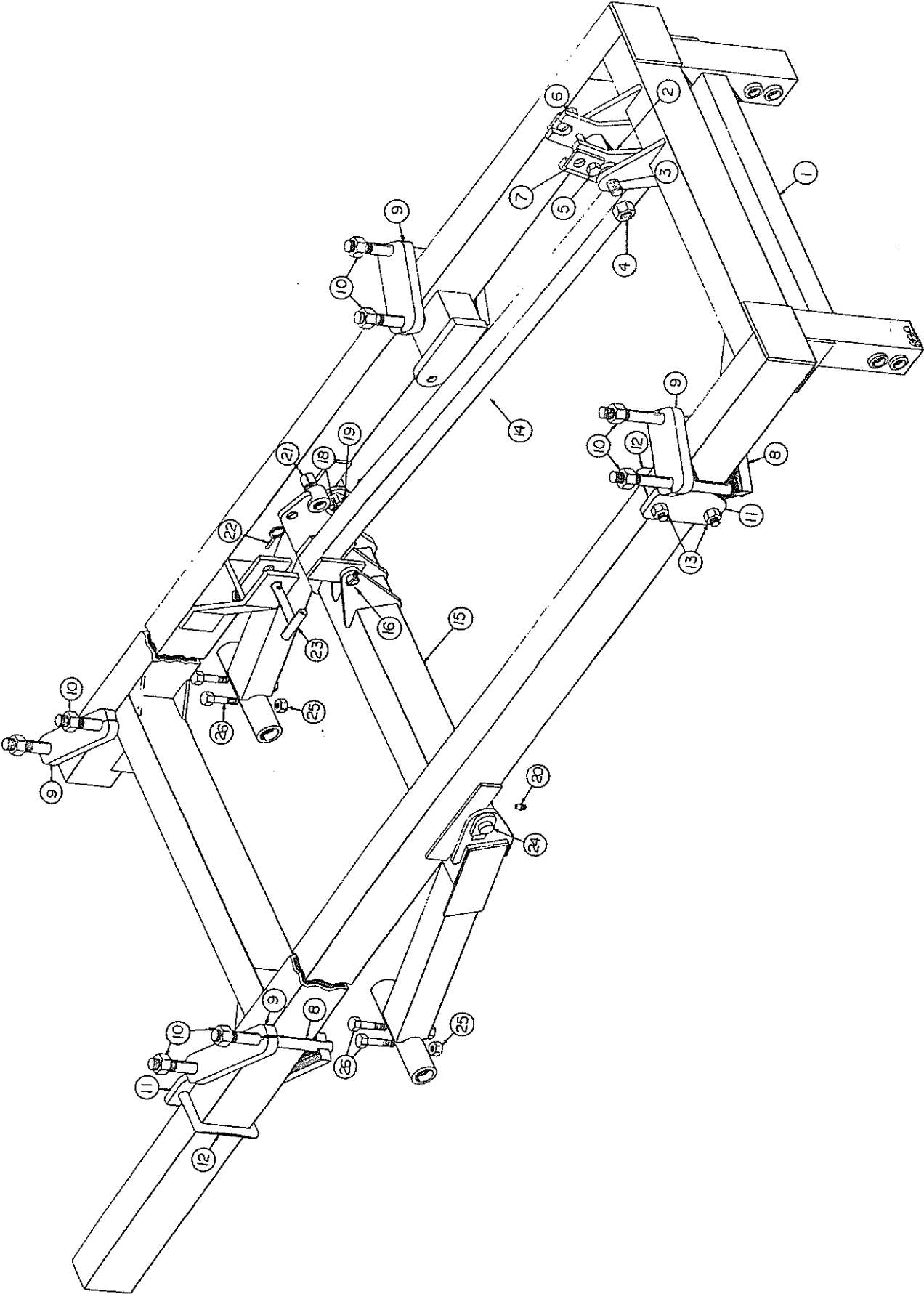



# 86" MAIN FRAME

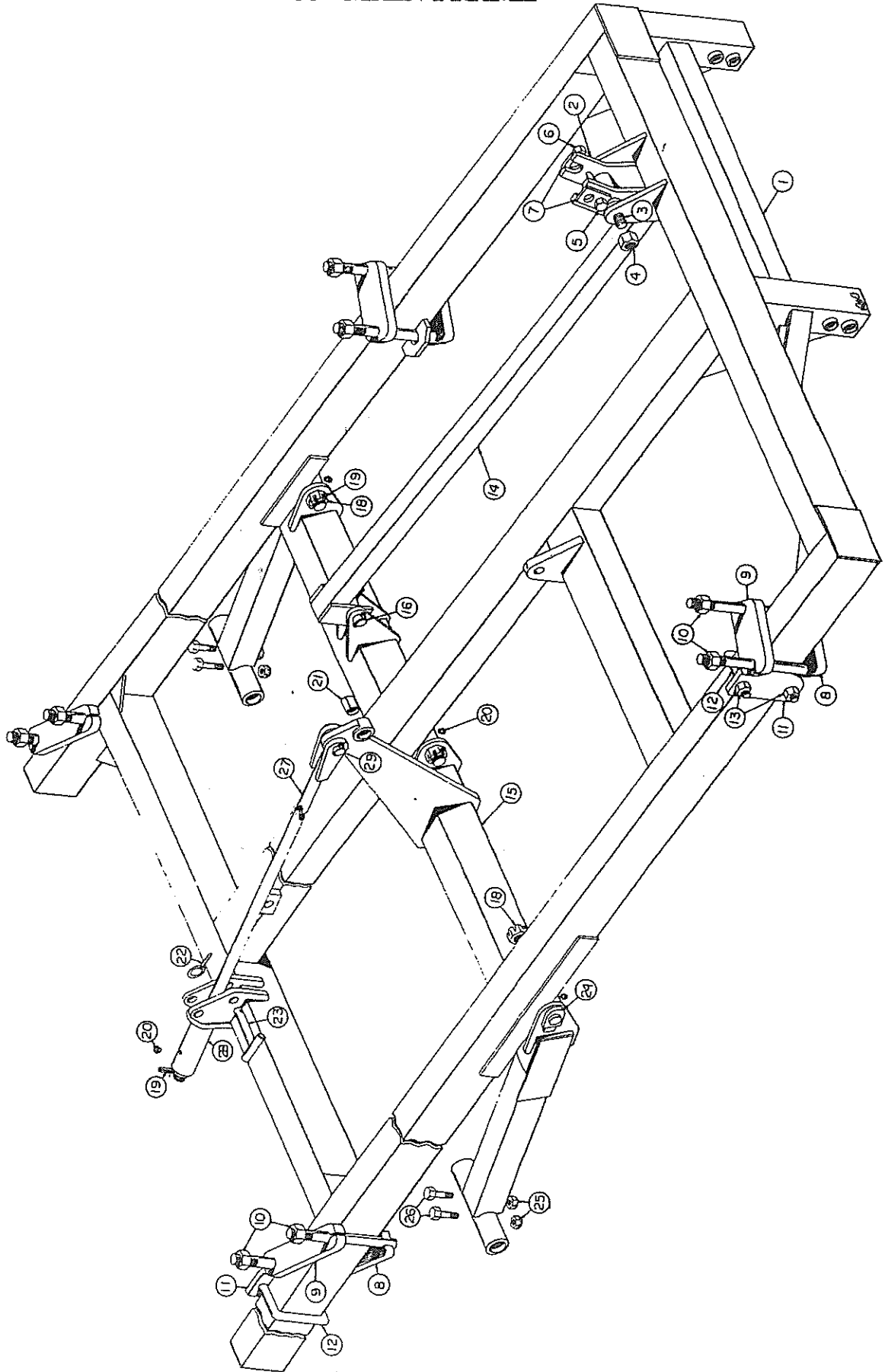

<b>AMCO</b>			
<b>F42** J42** J43** J44 SERIES</b>			
<b>86" MAIN FRAME &amp; ROCKSHAFT</b>			
<u>Ref. No.</u>	<u>Part No.</u>	<u>Description</u>	<u>No. Req'd.</u>
1	20030	Main Frame	1
2	20032	Pivot Bracket	1
3	20137	Pin 12" x 1-1/4" Long	1
4	10397	Lock Nut 1-1/4" NC, PL	1
5	10043	Hex Bolt 5/8" x 6-1/2"	1
6	10299	Lock Nut	1
7	9628	Clamp Trunnion	2
8	20637	Clamp	4
9	102679	Clamp Cap	4
10	10873	Hex Nut 1-3/8" NC, PL	8
11	100748	Gang Frame Clamp	4
12	9752	U-Bolt 7/8" Dia.	4
13	10396	Lock Nut 7/8" NC, PL	8
14	20033	Connector	1
15	20029	Rockshaft	1
16	101270	Pin .1" x 5-7/8" Long	2
17	10868	Lock Nut 1" NC, PL	2
18	10232	Hex Nut 1-1/2" NC, Slotted	3
19	10910	Roll Pin 5/16" x 2-1/4"	10
20	11081	Grease Fitting 5/16" Drive-In	4
21	11501	Bushing	1
22	10317	Klik Pin 1/4"	1
23	0871	Transport Pin	1
24	0866	Rockshaft Pivot Pin 7-5/8" Long	3
25	10395	Lock Nut 1/2" NC, PL	4
26	10834	Machine Bolt 1/2" x 4" NC, PL, Gr. 5	4
27	20035A	Depth Bar	1
28	*20264	Depth Gauge Stop	1
29	100963	Pin 1-1/4" Dia. X 3-3/4" Long	1
	9270	Bronze Bushing included in Rockshaft	
		Assembly Pivot Points	
	10855	Hex Screw 1/2" x 1" NC, PLT, Gr. 5	1
		NOTE: #10855 is set Screw for #20264	
		Depth Gauge Stop	

**AMCO**  
**F42\*\* J42\*\* J43\*\* J44 SERIES**  
**SPINDLE & HUB**

<u>Ref. No.</u>	<u>Part No.</u>	<u>Description</u>	<u>No. Req'd.</u>
1	10880	Spindle 1-15/16" Dia. X 13" Long	4
3	10256	Seal (C/R 22870)	4
4	10258	Cone - Inner (Timken #342A)	4
5	11297	Hub with 2 Cups, 6 Hub Bolts & 6 Hub Nuts	4
5	11299	Bolt - Hub 1/2" x 1-7/8" NF	24
5	11046	Nut Hub 1/2" NF	24
5	10257	Cup - Inner (Timken #332)	4
5	10261	Cup - Outer (Timken #14276)	4
6	10262	Cone - Outer (Timken #14137A)	4
7	10263	Washer - Spindle 7/8"	4
8	10291	Cotter Pin 5/32" x 1-1/4"	4
9	10264	Nut 7/8" NF, Slotted	4
10	10242	Hub Cap	4
11	10936	Wheel 15 x 8 - 6 Bolt	4
11	11236	Wheel 15 x 10 - 6 Bolt (Optional)	4
NOTE: Use on 50" & 86" Main Frame before Serial # 95020046 -- (Spindle & Hub Assy. -- remain the same for 50" frames)			

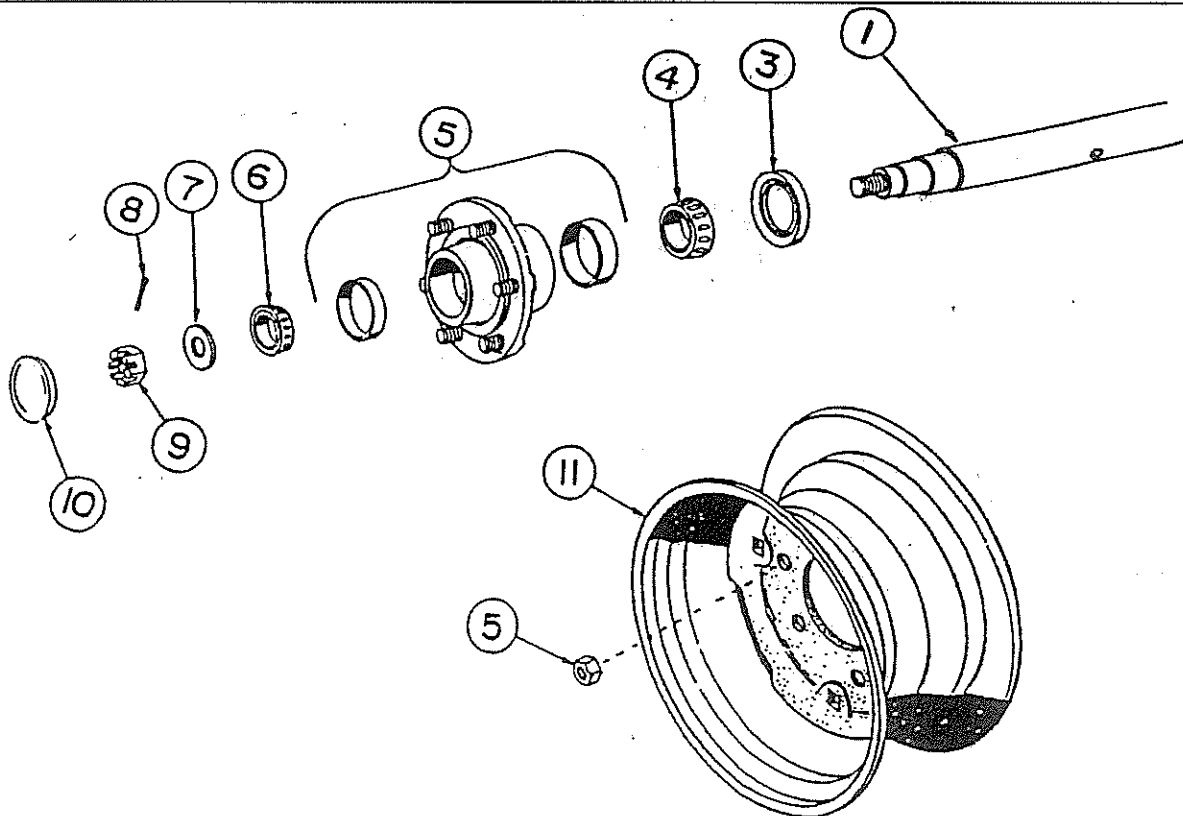



# J42, J43, J44 INSERT

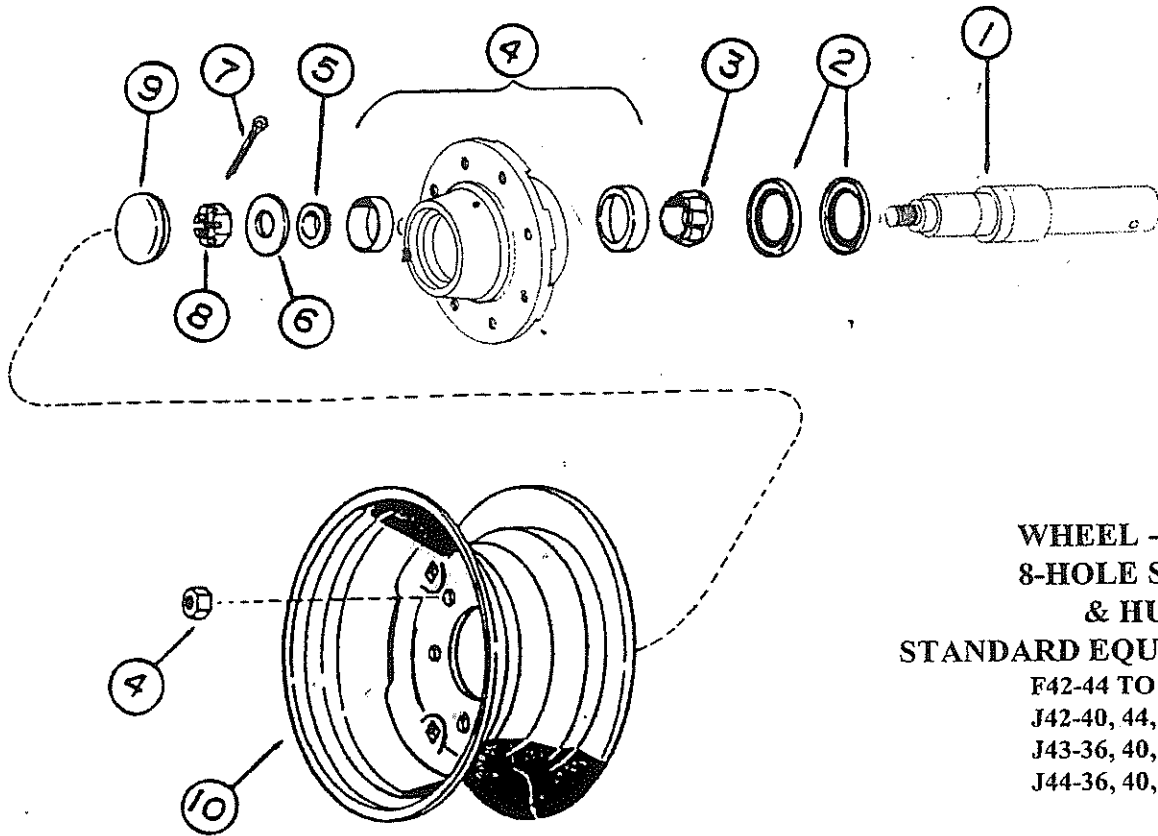

**WHEEL - 8-HOLE**  
**8-HOLE SPINDLE**  
**& HUB ASSY.**  
**STANDARD EQUIPMENT**  
 F42-44 TO 48 BLADE  
 J42-40, 44, 48 BLADE  
 J43-36, 40, 44 BLADE  
 J44-36, 40, 44 BLADE

SPINDLE & HUB

AMCO			
J42** J43** J44 SERIES			
SPINDLE & HUB			
Ref. No.	Part No.	Description	No. Req'd.
1	12164	Spindle	4
2	12191	Seal	4
3	12187	Cone - Outer	4
4	12186-1	Hub with 2 Cups, Grease Fittings & Press in Studs with Nuts	4
4	12189	Cup - Inner	4
4	12190	Cup - Outer	4
4	12192	Hub Bolt	32
4	12193	Hub Nut 34 - 16NF	32
5	12188	Cone - Inner	4
6	12195	Washer - Spindle	4
7	12197	Cotter Pin - Spindle	4
8	12196	Nut - Spindle	4
9	12198	Hub Cap	4
10	12305	Wheel 15 x 10 - 8 Hole (Heavy Duty)	4
11	10606	Grease Fitting (Not Shown)	4
NOTE: BC-05-0331 - Sub Bundle Spindle & Hub Complete			

# AMCO F42, J42, J43 & J44 AUXILIARY FRAME

<u>Ref. No.</u>	<u>Part No.</u>	<u>Description</u>	<u>No. Req'd</u>
1	20090	Assy. Short Rail .....	1
2	20091	Assy. Long Rail .....	1
3	20637	Assy. Clamp .....	4
4	102679	Clamp Cap .....	4
5	10873	Hex Nut 1-3/8 NC, PL .....	8

F42 Model - Use with 44, 48, & 54-Blade

J42 Model - Use with 36, 40, & 44-Blade

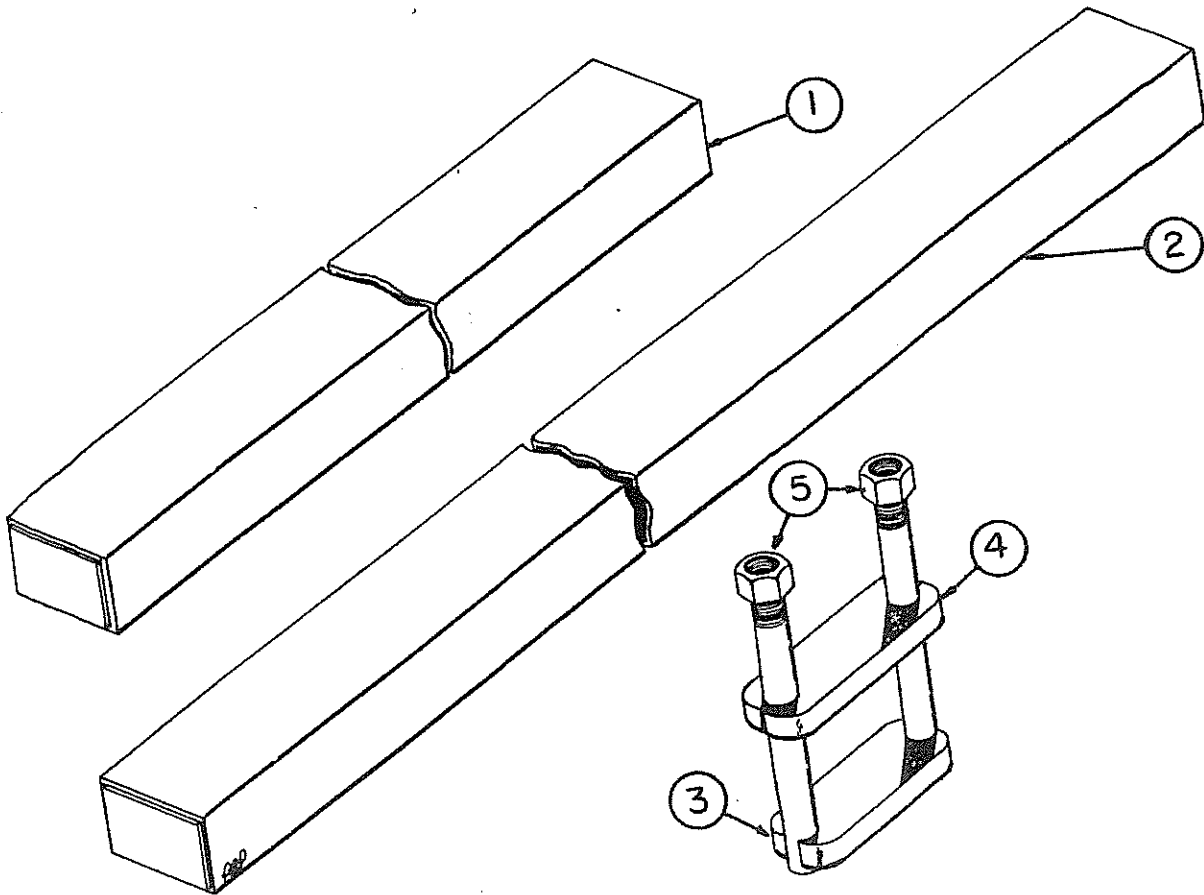

## 4 x 8 HYDRAULIC CYLINDER (LION) 3000 PSI

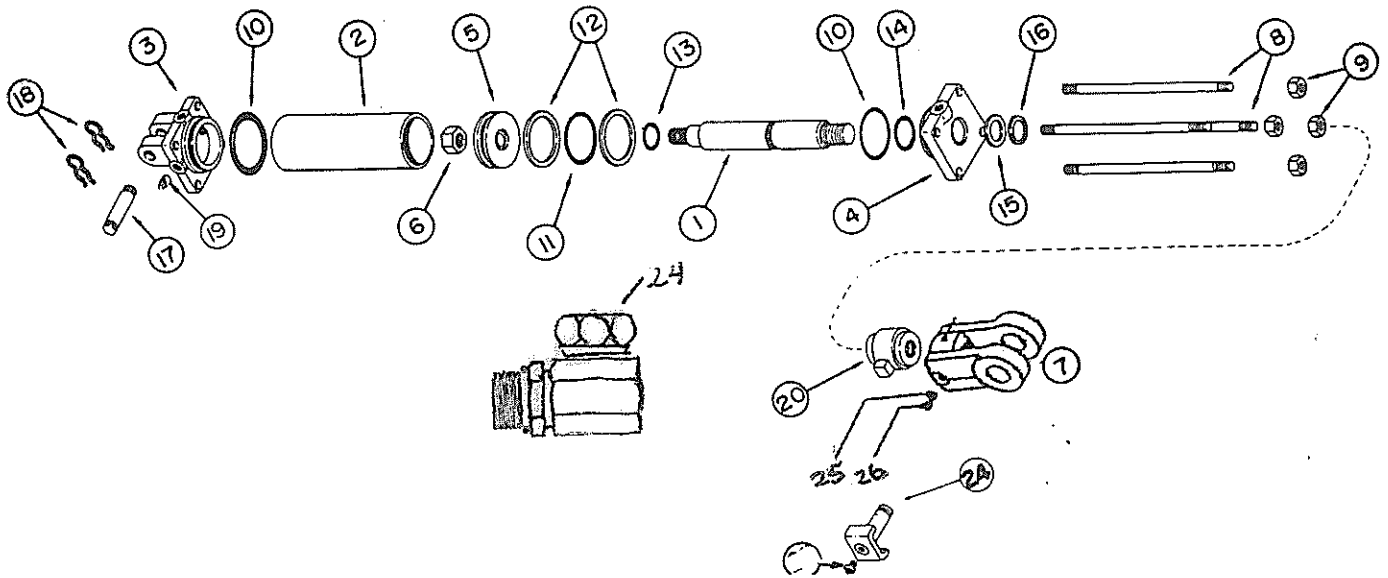

<b>AMCO</b>			
<b>F42**J42**J43**J44 SERIES</b>			
<b>4 x 8 HYDRAULIC CYLINDER (LION) 3000 PSI</b>			
<u>Ref. No.</u>	<u>Part No.</u>	<u>Description</u>	<u>No. Req'd.</u>
	12203	4 X 8 Cylinder Complete	
1	12383	Piston Rod	1
2	12243	Tube	1
3	12243	Butt	1
4	12244	Piston Head	1
5	12245	Piston	1
6	12246	Lock Nut 1-1/8" UNF, Gr. C	1
7	11502	Clevis for 1-14/4" Dia. Pin	1
8	12247	Tie Rod 5/8" x 8"	4
9	12248	Hex Nut 5/8" UNF, Gr. 5	4
17	10956	Clevis Pin - 1" x 4"	1
18	10957	Clip	2
19	12277	Pipe Plug - 3/4" - 16 UNF ORB	1
20	10937	Stroke Control	1
21	12235	Seal Repair Kit	1
10		O-Ring	2
11		O-Ring	1
12		Washer	2
13		O-Ring	1
14		O-Ring	1
15		Washer	1
16		Wiper	1
22	20570	Pin 1-1/4" Dia. With lub fitting & 5/16" x 2-1/4" Roll Pin	1
23	11081	Grease Fitting	1
24	12180	Adapter 1/2" to 1/2" ORB ASAE Thread	2
25	12302	Nylon Thread Lock	1
26	12288	Socket Set Screw 3/8" UNC x 1/2" KNUR	1
<b>NOTE:</b> Seal Repair Kit Parts available in Repair Kits Only (Ref. No 10-16). Beginning with Serial # 95110416 use this Cylinder.			

## 4 x 16 HYDRAULIC CYLINDER (LION) 3000 PSI

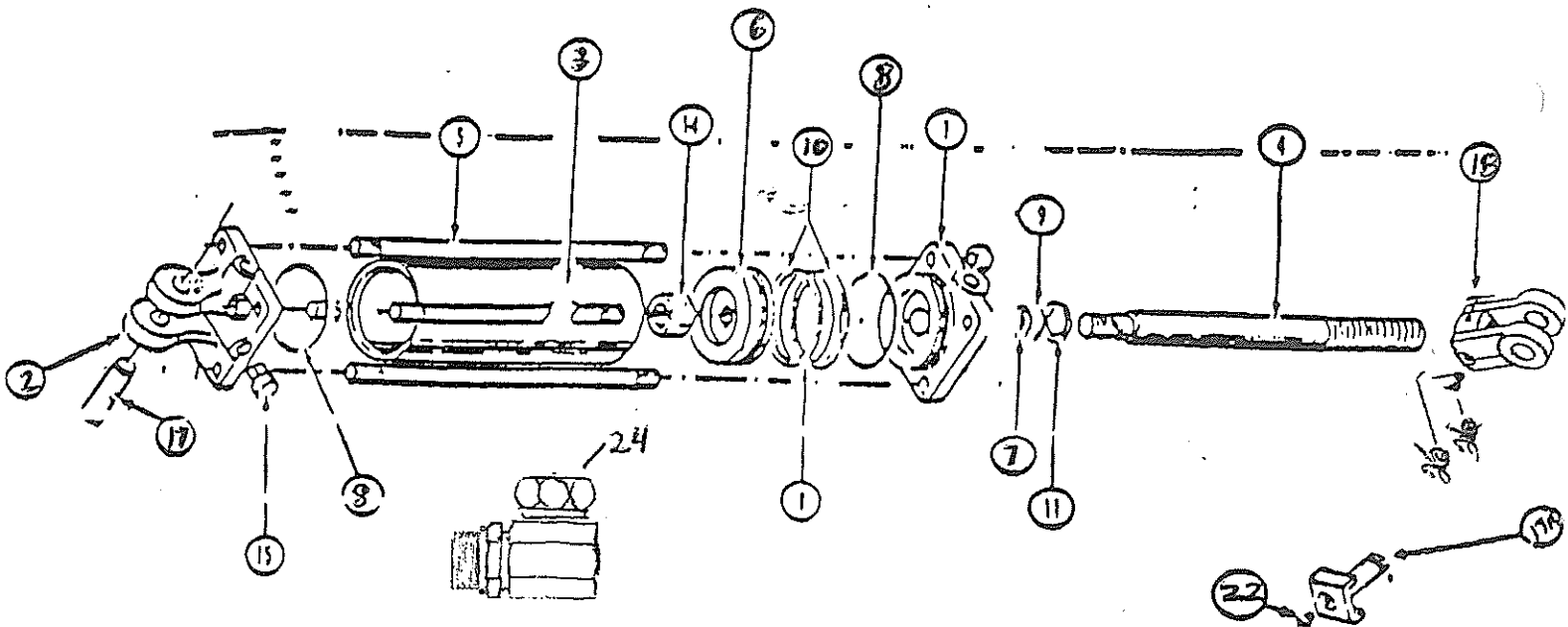

<b>AMCO</b>			
<b>F42** J42** J43** J44 SERIES</b>			
<b>4 x 16 HYDRAULIC CYLINDER (LION) 3000 PSI</b>			
<u>Ref. No.</u>	<u>Part No.</u>	<u>Description</u>	<u>No. Req'd.</u>
	12204	Cylinder Complete	1
1	12249	Head - Piston	1
2	12234	Butt	1
3	12250	Tube	1
4	12251	Piston Rod	1
5	12252	Tie Rod	4
6	12253	Piston	1
7		O-Ring	1
8		O-Ring	3
9		Washer	1
10		Washer	2
11		Rod Wiper	1
14	12246	Lock Nut 1-1/8" - 12 UNF, Gr. C	1
15	12277	Plug 3/4" - 16 UNF, ORB	1
17	100171	Cylinder Pin	1
17A	20570	Pin 1-1/4" (with Lub Fitting & 5/16 x 2-1/4 Roll Pin)	1
18	11502	Clevis	1
21	10910	Roll Pin 5/16" x 2-1/4" (not shown)	3
22	11081	Grease Fitting	1
23	10077	1-1/4" Cut Washer PLT (Not Shown)	2
24	12180	Adapter 1/2" to 1/2" ORB ASAE Thread	2
25	12302	Nylon Thread Lock	1
26	12288	Socket Set Screw 3/8" UNC x 1/2" KNUR	1
<b>NOTE:</b> Items 7, 8, 9, 10 & 11 sold in Repair Kit only. Use this cylinder beginning with Serial# 95060243.			

<b>SPINDLE &amp; HUB</b>			
<u>Ref. No.</u>	<u>Part No.</u>	<u>Description</u>	<u>No. Req'd.</u>
1	10922	Spindle 2-7/32" Dia. X 14-1/2" Long	4
2	10467	Seal (C/R 52430)	4
3	10469	Cone - Inner (Timken #25590)	4
4	10463-1	Hub with 2 Cups, 6 Hub Bolts & Nuts	4
4	10468	Cup - Inner (Timken #25520)	4
4	10472	Cup - Outer (Timken #25821)	4
4	10470	Hub Bolt 9/16" x 2-1/4" NF	24
4	10471	Hub Nut 9/16" NF	24
5	10473	Cone - Outer (Timken # 25877)	4
6	10263	Washer 7/8"	4
7	10291	Cotter Pin 5/32" x 1-1/4"	4
8	10264	Nut 7/8" NF, Slotted	4
9	10474	Hub Cap	4
10	11236	Wheel 15 x 10 - 6 Bolt (Optional)	4
	JA-05-0024	Sub Bundle Spindle & Hub Complete	4
NOTE: Use on 86" Main Frame only after Serial # 95020046			

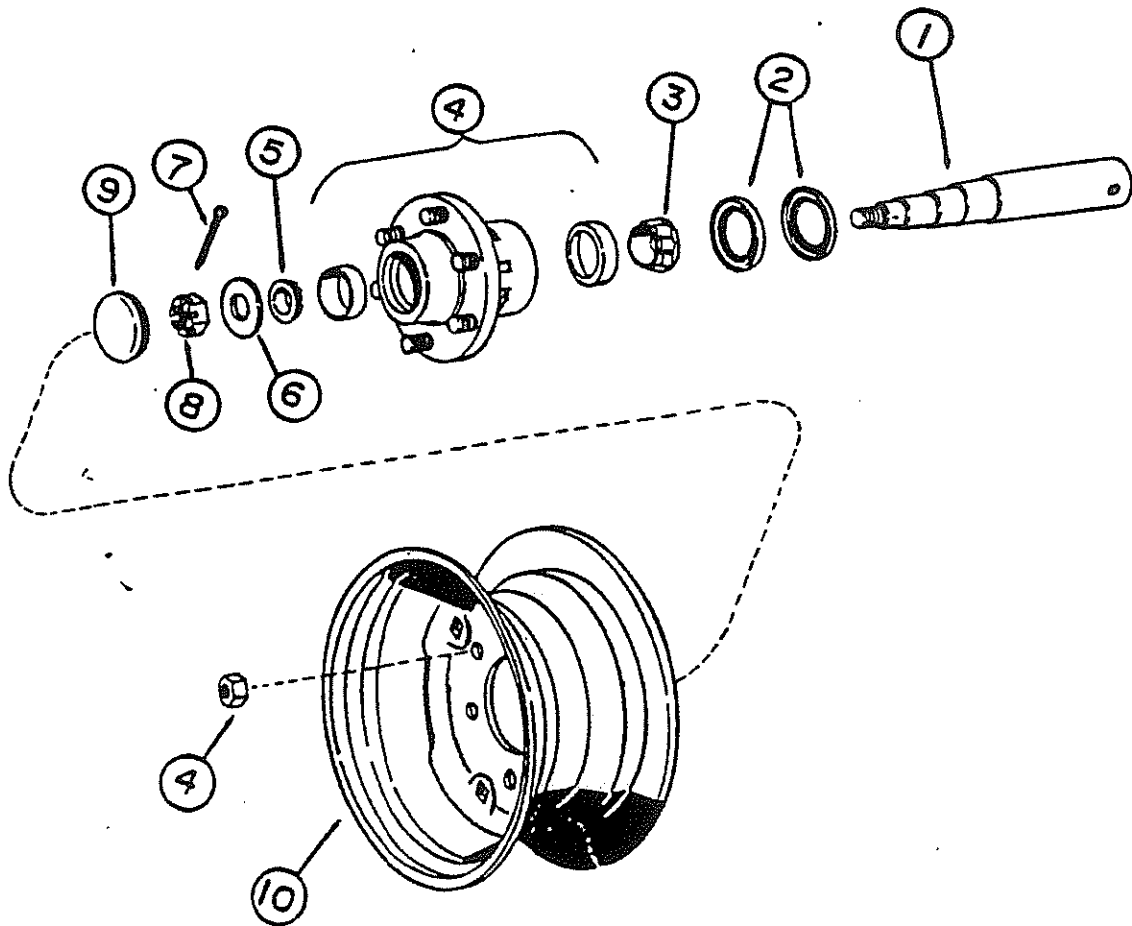

# F42 FRONT GANG & FRAME

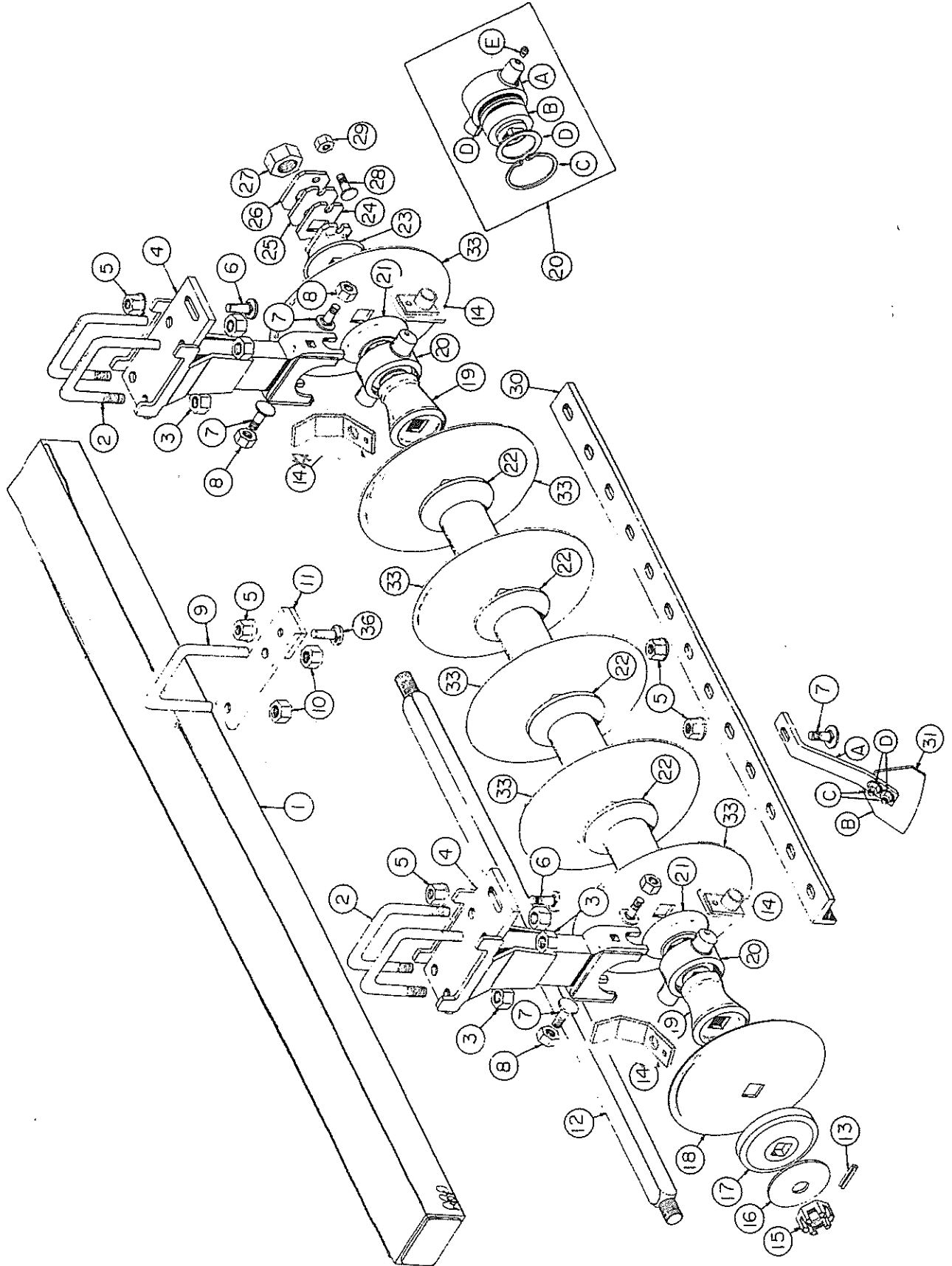

AMCO										
F42										
FRONT GANG & FRAME										
Ref. No.	Part No.	Description	No. Req'd. Blades							
			22	24	28	32	36	40	44	48
1	0503	Assy. Gang Frame - 102"	1							
1	0504	Assy. Gang Frame - 108"		1						
1	0506	Assy. Gang Frame - 126"			1					
1	0508	Assy. Gang Frame - 144"				1				
1	0487	Assy. Gang Frame - 165"					1			
1	0488	Assy. Gang Frame - 183"						1		
1	0492	Assy. Gang Frame - 200"							1	
1	0494	Assy. Gang Frame - 219"								1
2	9752	U-Bolt 7/8" Dia.	8	8	8	10	13	13	15	17
3	10396	Lock Nut 7/8" NC, PL	16	16	16	20	26	26	30	34
4	20070	Assy. Bearing Riser	4	4	4	5	6	6	7	8
5	11647	Flange Lock Nut 5/8" NC, PL	14	15	17	19	23	25	30	32
6	10665	Carriage Bolt 5/8" x 2 NC, PL, Gr. 5	4	4	4	5	6	6	7	8
7	10135	Carriage Bolt 5/8" x 1-3/4" NC, PL, Gr. 5	18	19	21	25	29	31	35	39
8	10299	Lock Nut 5/8" NC, PL	8	8	8	10	12	12	14	16
9	9212	U-bolt 3/4" Dia.			2	1		2	2	1
10	10300	Lock Nut 3/4" NC, PL			4	2		4	4	2
11	20074	Assy. Support			2	1		2	2	1
12	9441	Gang Bolt 1-1/2" Sq. - 42-7/8" - 5 Blade	1							
12	9442	Gang Bolt 1-1/2" Sq. - 52-3/8" - 6 Blade		1				1		
12	9443	Gang Bolt 1-1/2" Sq. - 61-3/8" - 7 Blade		1	2			2	2	1
12	9445	Gang Bolt 1-1/2" Sq. - 79-7/8" - 9 Blade				1	2			1
12	9444	Gang Bolt 1-1/2" Sq. - 70-5/8" - 8 Blade							1	1
13	10910	Roll Pin 5/16" x 2-1/4"	2	2	2	2	2	3	3	3
14	20579	Grease Guard	4	4	4	5	6	6	7	8
14A	102489	Wear Guard	4	4	4	5	6	6	7	8
15	10226	Nut Gang Bolt 1-1/2" NF, Slotted	2	2	2	2	2	3	3	3
16	10872	Cut Washer 1-3/8" PL	2	2	2	2	2	3	3	3
17	2404	Bumper Washer	2	2	2	2	2	3	3	3
18	3276	Blade 22 x 1/4 PL	2	2	2	2	2	2	2	2
18	3275	Blade 22 x 1/4 C.O.	2	2	2	2	2	2	2	2
19	17007	End Bell - Small	4	4	4	5	6	6	7	8
20	FB-09-0015	Sub. Assy. Bearing & Housing	4	4	4	5	6	6	7	8
A	16003	Housing - Bearing	1	1	1	1	1	1	1	1
B	11503	Bearing	1	1	1	1	1	1	1	1
C	11064	Snap Ring	1	1	1	1	1	1	1	1
D	100104	Washer 100mm	2	2	2	2	2	2	2	2
E	12384	Grease Fitting 1/8" NPT	1	1	1	1	1	1	1	1
21	17008	End Bell - Large	4	4	4	5	6	6	7	8
22	0522	Spacer Spool	5	6	8	9	10	11	12	13
23	122A	End Gang Washer	2	2	2	2	2	3	3	3
24	100099	Spacer Plate	2	2	2	2	2	3	3	3
25	100098	Bearing Plate	2	2	2	2	2	3	3	3
26	5622A	Lock Plate	2	2	2	2	2	3	3	3
27	10489	Nut Gang Bolt 1-1/2" NF, Slotted	2	2	2	2	2	3	3	3
28	10710	Carriage Bolt 1/2" x 2" NC, PL, Gr. 5	2	2	2	2	2	3	3	3
29	10395	Lock Nut 1/2" NC, PL	2	2	2	2	2	3	3	3
30	101084	Scraper Bar 3 x 2 x 3/8 - 96-3/4	1							
30	101086	Scraper Bar 3 x 2 x 3/8 - 106		1						
30	101076	Scraper Bar 3 x 2 x 3/8 - 59-3/4			2	1		1	2	1
30	101080	Scraper Bar 3 x 2 x 3/8 - 78-1/4				1				1
30	101074	Scraper Bar 3 x 2 x 3/8 - 50-1/2						1		
30	101078	Scraper Bar 3 x 2 x 3/8 - 69							1	1
31	20068	Assy. Scraper - RH	10	11	13	15	17	19	21	23
A	101049	Scraper Shank	1	1	1	1	1	1	1	1
B	101019	Scraper Blade	1	1	1	1	1	1	1	1
C	11652	Machine Bolt (Black) 1/2 x 1-1/4 NC, Gr. 5	2	2	2	2	2	2	2	2
D	10395	Lock Nut 1/2" NC, PL	2	2	2	2	2	2	2	2
33	3255	Blade 24 x 1/4 PL	9	10	13	14	16	18	20	22
34	3250	Blade 24 x 1/4 C.O.	9	10	12	14	16	18	20	22
35	3278	Blade 10 x 11 Ga. PL Back-up	1	1	1	1	1	1	1	1
36	10722	Carriage Bolt 5/8 x 2-1/2 NC, PL			2	1		2	2	1

F42  
REAR GANG & FRAME

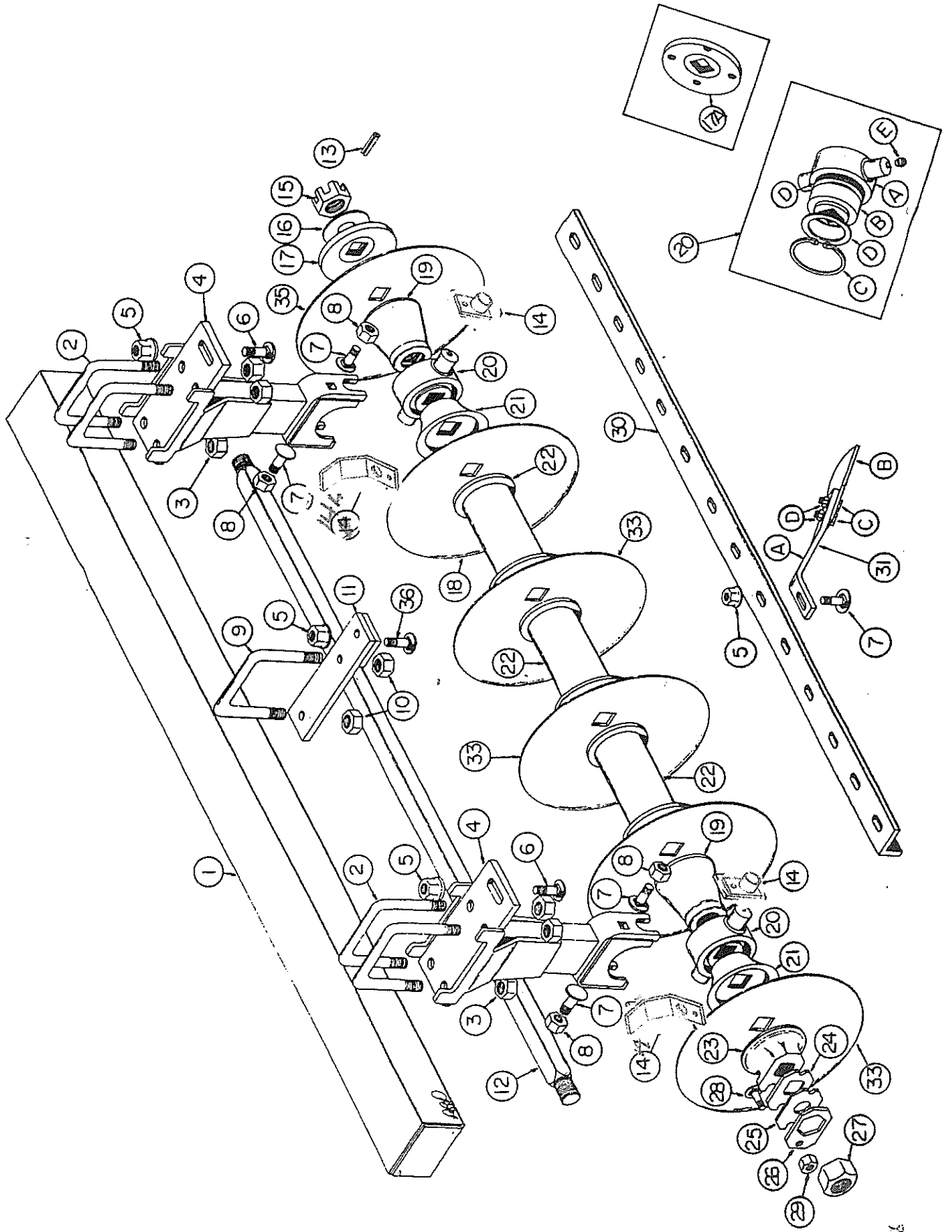



AMCO										
F42										
REAR GANG & FRAME										
Ref. No.	Part No.	Description	Blades							
			22	24	28	32	36	40	44	48
1	0503	Assy. Gang Frame - 102"	1							
1	0504	Assy. Gang Frame - 108"		1						
1	0506	Assy. Gang Frame - 126"			1					
1	0508	Assy. Gang Frame - 144"				1				
1	0487	Assy. Gang Frame - 165"					1			
1	0488	Assy. Gang Frame - 183"						1		
1	0492	Assy. Gang Frame - 200"							1	
1	0494	Assy. Gang Frame - 219"								1
2	9752	U-Bolt 7/8" Dia.	8	8	8	10	13	13	15	17
3	10396	Lock Nut 7/8" NC, PL	16	16	16	20	26	26	30	34
4	20070	Assy. Bearing Riser	4	4	4	5	6	6	7	8
5	11647	Flange Lock Nut 5/8" NC, PL	14	15	19	21	23	27	30	32
6	10665	Carriage Bolt 5/8 x 2 NC, PL, Gr. 5	4	4	6	6	6	6	7	8
7	10135	Carriage Bolt 5/8 x 1-3/4 NC, PL, Gr. 5	18	19	21	25	29	31	35	39
8	10299	Lock Nut 5/8 NC, PL	8	8	8	10	12	12	14	16
9	9212	U-Bolt 3/4" Dia.			2	1		2	2	1
10	10300	Lock Nut 3/4" NC, PL			4	2		4	4	2
11	20074	Assy. Support			2	1		2	2	1
12	9441	Gang Bolt 1-1/2" Sq. - 42-7/8 - 5 Blade	1							
12	9442	Gang Bolt 1-1/2" Sq. - 52-3/8 - 6 Blade	1	2						
12	9443	Gang Bolt 1-1/2" Sq. - 61-3/8 - 7 Blade			2	1		2	2	1
12	9445	Gang Bolt 1-1/2" Sq. - 79-7/8 - 9 Blade				1	2			1
12	9444	Gang Bolt 1-1/2" Sq. - 70-5/8 - 8 Blade							1	1
13	10910	Roll Pin 5/16 x 2-1/4	2	2	2	2	2	3	3	3
14	20579	Grease Guard	4	4	4	5	6	6	7	8
14A	102489	Wear Guard	4	4	4	5	6	6	7	8
15	10226	Nut Gang Bolt 1-1/2 NF, Slotted	2	2	2	2	2	3	3	3
16	10872	Cut Washer 1-3/8 PL	2	2	2	2	2	3	3	3
17	2404	Bumper Washer	1	1	1	1	1	2	2	2
17A	100738A	Bumper Washer	1	1	1	1	1	1	1	1
18	3276	Blade 22 x 1/4 PL	1	1	1	1	1	1	1	1
18	3275	Blade 22 x 1/4 C. O.	1	1	1	1	1	1	1	1
19	17007	End Bell - Small	4	4	4	5	6	6	7	8
20	FB-09-0015	Sub. Assy. Bearing & Housing	4	4	4	5	6	6	7	8
A	16003	Housing Bearing	1	1	1	1	1	1	1	1
B	11503	Bearing	1	1	1	1	1	1	1	1
C	11064	Snap Ring	1	1	1	1	1	1	1	1
D	100104	Washer 100mm	2	2	2	2	2	2	2	2
E	12384	Grease Fitting 1/8 NPT Straight	1	1	1	1	1	1	1	1
21	17008	End Bell - Large	4	4	4	5	6	6	7	8
22	0522	Spacer Spool	5	6	8	9	10	11	12	13
23	1222A	End Gang Washer	2	2	2	2	2	3	3	3
24	100099	Spacer Plate	2	2	2	2	2	3	3	3
25	100098	Bearing Plate	2	2	2	2	2	3	3	3
26	5622A	Lock Plate	2	2	2	2	2	3	3	3
27	10489	Nut Gang Bolt 1-1/2 NF	2	2	2	2	2	3	3	3
28	10710	Carriage Bolt 1/2 x 2 NC, PL, Gr. 5	2	2	2	2	2	3	3	3
29	10395	Lock Nut 1/2 NC, PL	2	2	2	2	2	3	3	3
30	101084	Scraper Bar 3 x 2 x 3/8 - 96-3/4	1							
30	101086	Scraper Bar 3 x 2 x 3/8 - 106		1						
30	101076	Scraper Bar 3 x 2 x 3/8 - 59-3/4			2	1		1	2	1
30	101080	Scraper Bar 3 x 2 x 3/8 - 78-1/4				1				
30	101074	Scraper Bar 3 x 2 x 3/8 - 50-1/2						1		
30	101078	Scraper Bar 3 x 2 x 3/8 - 69							1	1
31	20069	Assy. Scraper - LH	10	11	13	15	17	19	21	23
A	101049	Scraper Shank	1	1	1	1	1	1	1	1
B	101019	Scraper Blade	1	1	1	1	1	1	1	1
C	11652	Machine Bolts (Black) 1/2 x 1-1/4 NC, Gr.5	2	2	2	2	2	2	2	2
D	10395	Lock Nut 1/2 NC, PL	2	2	2	2	2	2	2	2
33	3255	Blade 24 x 1/4 PL	9	10	12	14	16	18	20	22
34	3250	Blade 24 x 1/4 C. O.	9	10	12	14	16	18	20	22
35	9481	Blade 20 x 3/16 PL	1	1	1	1	1	1	1	1
35	9487	Blade 20 x 3/16 C. O.	1	1	1	1	1	1	1	1
36	10722	Carriage Bolt 5/8 x 2-1/2 NC, PL						2	2	1

J42  
FRONT GANG & FRAME

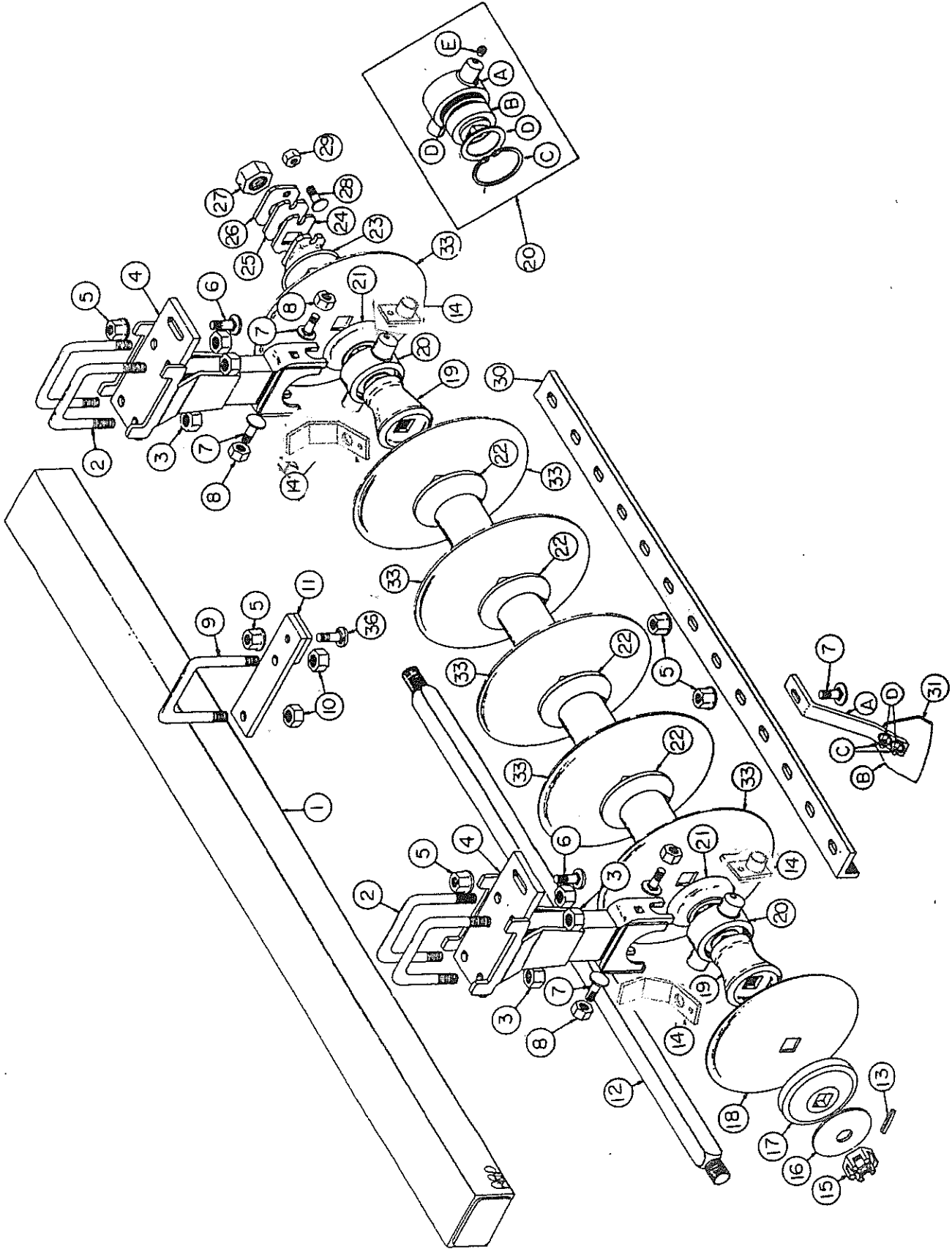

AMCO										
J42										
FRONT GANG & FRAME										
Ref. No.	Part No.	Description	22	24	28	No. Req'd. Blades				
						32	36	40	44	48
1	0503	Assy. Gang Frame - 102"	1							
1	0506	Assy. Gang Frame - 126"		1						
1	0508	Assy. Gang Frame - 144"			1					
1	0487	Assy. Gang Frame - 165"				1				
1	0519	Assy. Gang Frame - 187"					1			
1	0493	Assy. Gang Frame - 209"						1		
1	0516	Assy. Gang Frame - 228"							1	
1	518	Gang Frame								1
2	9752	U-Bolt 7/8" Dia.	6	8	10	13	13	13	17	17
3	10396	Lock Nut 7/8" NC, PL	12	16	20	26	26	26	34	34
*4	20070	Assy. Bearing Riser	3	4	5	6	6	6	8	8
5	11647	Flange Lock Nut 5/8" NC, PL	12	16	18	21	23	26	29	29
6	10665	Carriage Bolt 5/8 x 2 NC, PL, Gr. 5	3	4	5	6	6	6	8	8
7	10135	Carriage Bolt 5/8 x 1-3/4 NC, PL, Gr. 5	15	19	23	27	29	31	37	37
8	10299	Lock Nut 5/8 NC, PL	6	8	10	12	12	12	16	16
9	9212	U-bolt 3/4 Dia.		1				1		
10	10300	Lock Nut 3/4 NC, PL		2				2		
11	20074	Assy. Support		1				1		
12	9455	Gang Bolt 1-1/2" Sq. 103-1/4" - 10 Blade	1					2		
12	9450	Gang Bolt 1-1/2" Sq. 103-1/4" - 5 Blade		1						
12	9444	Gang Bolt 1-1/2" Sq. 70-5/8" - 7 Blade		1						1
12	9451	Gang Bolt 1-1/2" Sq. 60-1/4" - 6 Blade			1				1	
12	9453	Gang Bolt 1-1/2" Sq. 81-3/4" - 8 Blade			1	2			2	1
12	9454	Gang Bolt 1-1/2" Sq. 92-1/2" - 9 Blade					2			1
13	10910	Roll Pin 5/16 x 2-1/4	1	2	2	2	2	2	2	2
14	20579	Grease Guard	3	4	5	6	6	6	8	8
14A	102489	Wear Guard	3	4	5	6	6	6	8	8
15	10226	Nut Gang Bolt 1-1/2 NF, Slotted	1	2	2	2	2	2	3	3
16	10872	Cut Washer 1-3/8 PL	1	2	2	2	2	2	3	3
17	2404	Bumper Washer	1	2	2	2	2	2	3	3
18	3255	Blade 24 x 1/4 PL	2	2	2	2	2	2	2	2
18	3276	Blade 22 x 1/4 PL	2	2	2	2	2	2	2	2
18	3275	Blade 22 x 1/4 C. O.	2	2	2	2	2	2	2	2
18	3250	Blade 24 x 1/4 C.O.	2		2	2	2	2	2	2
19	17007	End Bell - Small	3	4	5	6	6	6	8	8
20	FB-09-0015	Sub. Assy. Bearing & Housing	3	4	5	6	6	6	8	8
A	16003	Housing - Bearing	1	1	1	1	1	1	1	1
B	11503	Bearing	1	1	1	1	1	1	1	1
C	11064	Snap Ring	1	1	1	1	1	1	1	1
D	100104	Washer 100mm	2	2	2	2	2	2	2	2
E	12384	Grease Fitting 1/8 NPT	1	1	1	1	1	1	1	1
21	17006	End Bell - Large	3	4	5	6	6	6	8	8
22	0523	Spacer Spool	6	7	7	8	10	12	11	11
23	122A	End Gang Washer	1	2	2	2	2	2	3	3
24	100099	Spacer Plate	1	2	2	2	2	2	3	3
25	100098	Bearing Plate	1	2	2	2	2	2	3	3
26	5622A	Lock Plate	1	2	2	2	2	2	3	3
27	10489	Nut Gang Bolt 1-1/2 NF, Slotted	1	2	2	2	2	2	3	3
28	10710	Carriage Bolt 1/2 x 2 NC, PL, Gr. 5	1	2	2	2	2	2	3	3
29	10395	Lock Nut 1/2 NC, PL	1	2	2	2	2	2	3	3
30	101053	Scraper Bar 3 x 2 x 3/8 - 101-11/16"	1					2		
30	101070	Scraper Bar 3 x 2 x 3/8 - 123-1/16"		1						
30	101103	Scraper Bar 3 x 2 x 3/8 - 58-15/16"			1				1	
30	101050	Scraper Bar 3 x 2 x 3/8 - 80-5/16"			1	2			2	1
30	101051	Scraper Bar 3 x 2 x 3/8 - 91"					2			1
30	101104	Scraper Bar								1
31	20068	Assy. Scraper Bar- RH	9	11	13	15	17	19	21	23
A	101049	Scraper Shank	1	1	1	1	1	1	1	1
B	101019	Scraper Blade	1	1	1	1	1	1	1	1
C	11652	Machine Bolt (black) 1/2 x 1-1/4 NC, Gr.5	2	2	2	2	2	2	2	2
D	10395	Lock Nut 1/2 NC, PL	2	2	2	2	2	2	2	2
33	3255	Blade 24 x 1/4 PL	8	10	12	14	16	18	20	22
33	3263	Blade 26 x 1/4 PL	8	10	12	14	16	18	20	22
33	11576	Blade 26 x 5/16 PL	8	10	12	14	16	18	20	22
34	3250	Blade 24 x 1/4 C.O.	8	10	12	14	16	18	20	22
34	2456	Blade 26 x 1/4 C. O.	8	10	12	14	16	18	20	22
35	3278	Blade 10 x 11 Ga. PL - Back-up	1	1	1	1	1	1	1	1
36	10722	Carriage Bolt 5/8 x 2 x 1/2 NC, PL		1				1		
		NOTE: Use Part #20603 Bearing Riser with 28 Blades instead of Part #20070								

# J42 REAR GANG & FRAME

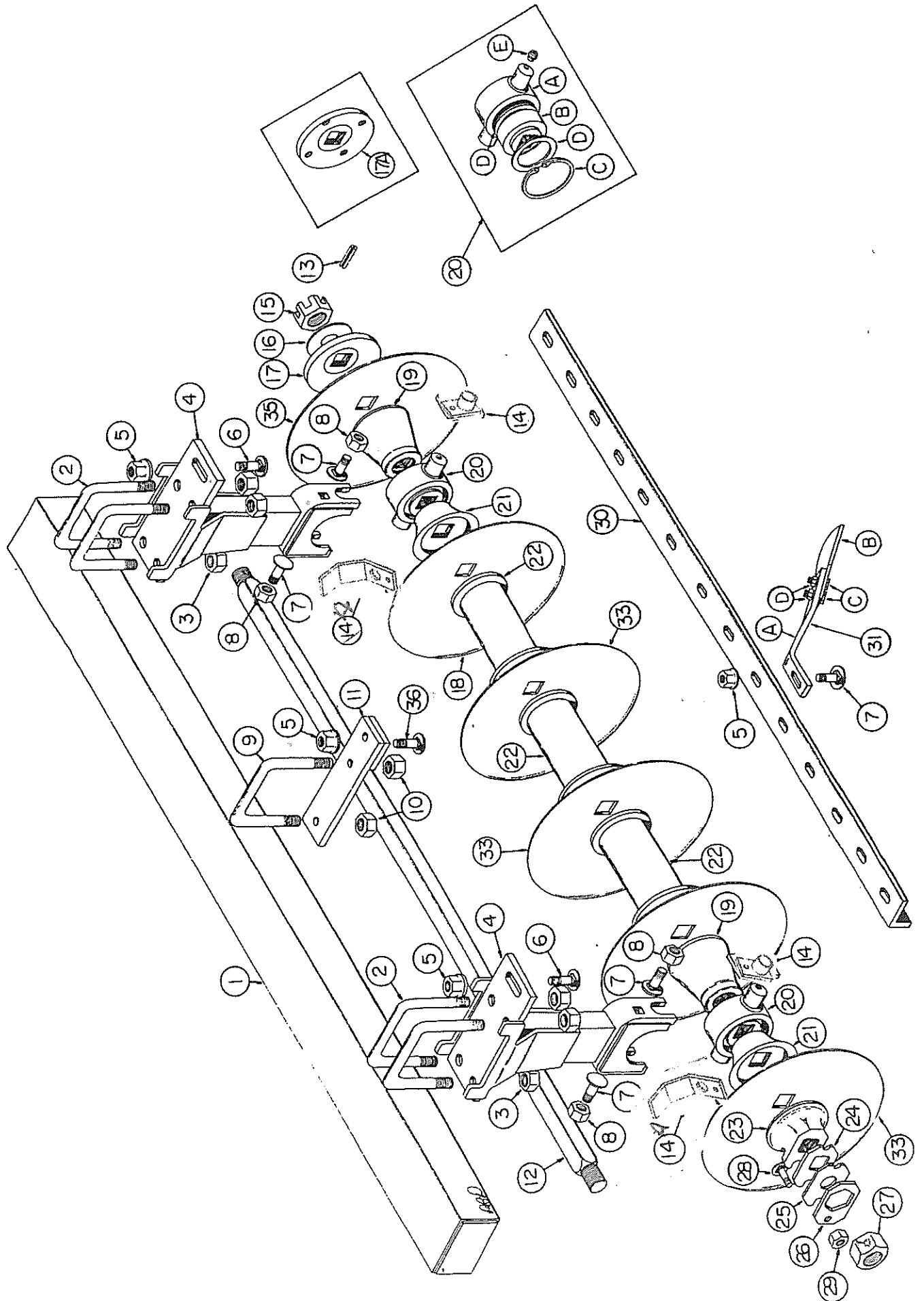

**AMCO  
J42  
REAR GANG & FRAME**

Ref. No.	Part No.	Description	No. Req'd. Blades								
			22	24	28	32	36	40	44	48	
1	0503	Assy. Gang Frame - 102"	1								
1	0506	Assy. Gang Frame - 126"		1							
1	0508	Assy. Gang Frame - 144"			1						
1	0487	Assy. Gang Frame - 165"				1					
1	0519	Assy. Gang Frame - 187"					1				
1	0493	Assy. Gang Frame - 209"						1			
1	0516	Assy. Gang Frame - 228"							1		
1	518	Assy. Gang Frame								1	
2	9752	U-bolt 7/8 Dia.	6	8	10	13	13	13	17	17	
3	10396	Lock Nut 7/8 NC, PL	12	16	20	26	26	26	34	34	
*4	20070	Assy. Bearing Riser	3	4	5	6	6	6	8	8	
5	11647	Flange Lock Nut 5/8 NC, PL	12	16	18	21	23	26	29	29	
6	10665	Carriage Bolt 5/8 x 2 NC, PL, Gr. 5	3	4	5	6	6	6	8	8	
7	10135	Carriage Bolt 5/8 x 1-3/4 NC, PL, Gr. 5	15	19	23	27	29	31	37	37	
8	10299	Lock Nut 5/8 NC, PL	6	8	10	12	12	12	16	16	
9	9212	U-Bolt 3/4 Dia.		1				1			
10	10300	Lock Nut 3/4 NC, PL		2				2			
11	20074	Assy. Support		1				1			
12	9455	Gang Bolt 1-1/2 Sq. - 103-1/4 - 10 Blade	1					2			
12	9450	Gang Bolt 1-1/2 Sq. - 49-1/2 - 5 Blade		1							
12	9444	Gang Bolt 1-1/2 Sq. - 70-5/8 - 7 Blade		1							1
12	9451	Gang Bolt 1-1/2 Sq. - 60-1/4 - 6 Blade			1					2	
12	9453	Gang Bolt 1-1/2 Sq. - 81-3/4 - 8 Blade			1	2				2	1
12	9454	Gang Bolt 1-1/2 Sq. - 92-1/2 - 9 Blade					2				1
13	10910	Roll Pin 5/16 x 2-1/4	1	2	2	2	2	2	3	3	
14	20579	Grease Guard	3	4	5	6	6	6	8	8	
14A	102489	Wear Guard	3	4	5	6	6	6	8	8	
15	10226	Nut Gang Bolt 1-1/2 NF, Slotted	1	2	2	2	2	2	3	3	
16	10872	Cut Washer 1-3/8 PL	1	2	2	2	2	2	3	3	
17	2404	Bumper Washer		1	1	1	1	1	2	2	
17A	100738A	Bumper Washer (Drilled & Tapped)	1	1	1	1	1	1	1	1	
18	3255	Blade 24 x 1/4 PL	1	1	1	1	1	1	1	1	
18	3276	Blade 22 x 1/4 PL	1	1	1	1	1	1	1	1	
18	3275	Blade 22 x 1/4 C.O.	1	1	1	1	1	1	1	1	
18	3250	Blade 24 x 1/4 C.O.	1	1	1	1	1	1	1	1	
19	17007	End Bell - Small	3	4	5	6	6	6	8	8	
20	FB-09-0015	Sub. Assy. Bearing & Housing	3	4	5	6	6	6	8	8	
A	16003	Housing - Bearing	1	1	1	1	1	1	1	1	
B	11503	Bearing	1	1	1	1	1	1	1	1	
C	11064	Snap Ring	1	1	1	1	1	1	1	1	
D	100104	Washer 100mm	2	2	2	2	2	2	2	2	
E	12384	Grease Fitting 1/8 NPT	1	1	1	1	1	1	1	1	
21	17006	End Bell - Large	3	4	5	6	6	6	8	8	
22	0523	Spacer Spool	6	7	7	8	10	12	11	11	
23	1222A	End Gang Washer	1	2	2	2	2	2	3	3	
24	100099	Spacer Plate	1	2	2	2	2	2	3	3	
25	100098	Bearing Plate	1	2	2	2	2	2	3	3	
26	5622A	Lock Plate	1	2	2	2	2	2	3	3	
27	10489	Nut Gang Bolt 1-1/2 NF	1	2	2	2	2	2	3	3	
28	10710	Carriage Bolt 1/2 x 2 NC, PL, Gr. 5	1	2	2	2	2	2	3	3	
29	10395	Lock Nut 1/2 NC, PL	1	2	2	2	2	2	3	3	
30	101052	Scraper Bar 3 x 2 x 3/8 - 101-11/16"	1					2			
30	101070	Scraper Bar 3 x 2 x 3/8 - 123-1/16"		1							
30	101103	Scraper Bar 3 x 2 x 3/8 - 58-5/16"			1					1	
30	101050	Scraper Bar 3 x 2 x 3/8 - 80-5/16"			1	2				2	1
30	101051	Scraper Bar 3 x 2 x 3/8 - 91"					2				1
30	101104	Scraper Bar									1
31	20069	Assy. Scraper - LH	9	11	13	15	17	19	21	23	
A	101049	Scraper Shank	1	1	1	1	1	1	1	1	
B	101019	Scraper Blade	1	1	1	1	1	1	1	1	
C	11652	Machine Bolts (black) 1/2 x 1-1/4 NC, Gr.5	2	2	2	2	2	2	2	2	
D	10395	Lock Nut 1/2 NC, PL	2	2	2	2	2	2	2	2	
33	3255	Blade 24 x 1/4 PL	8	10	12	14	16	18	20	22	
33	3263	Blade 26 x 1/4 PL	8	10	12	14	16	18	20	22	
33	11576	Blade 26 x 5/16 PL	8	10	12	14	16	18	20	22	
34	3250	Blade 24 x 1/4 C.O.	8	10	12	14	16	18	20	22	
34	2456	Blade 26 x 1/4 C.O.	8	10	12	14	16	18	20	22	
35	11588	Blade 20 x 1/4 PL	1	1	1	1	1	1	1	1	
35	11589	Blade 20 x 1/4 C.O.	1	1	1	1	1	1	1	1	
35	3276	Blade 22 x 1/4 PL	1	1	1	1	1	1	1	1	
35	3275	Blade 22 x 1/4 C.O.	1	1	1	1	1	1	1	1	

NOTE: Use Part #20603 Bearing Riser with 28 Blades instead of Part #20070.

# J43 FRONT GANG & FRAME

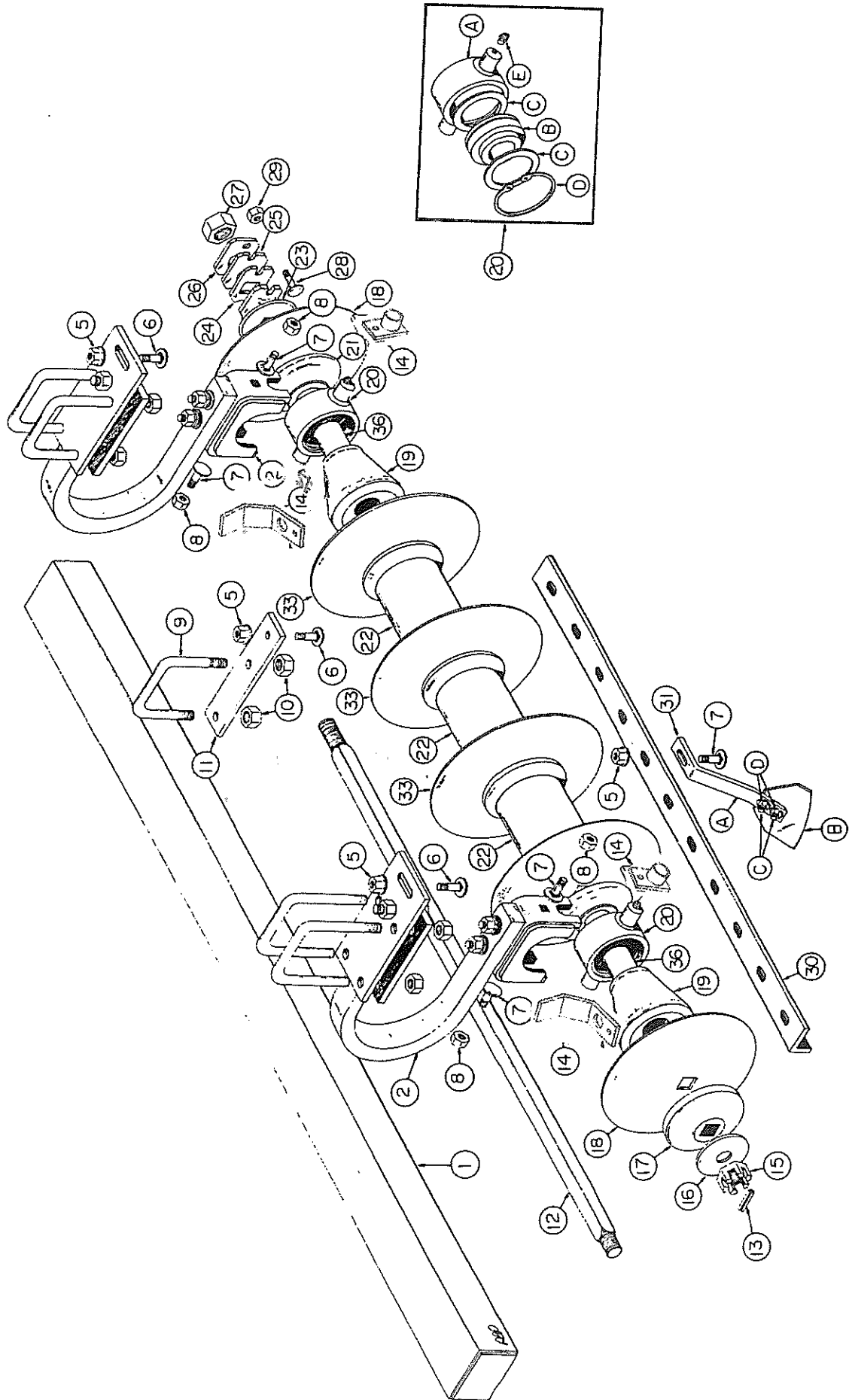

AMCO									
J43									
FRONT GANG & FRAME									
Ref. No.	Part No.	Description	22	24	28	Blades			
						No. 32	Req'd. 36	40	44
1	0503	Assy. Gang Frame - 102"	1						
1	0506	Assy. Gang Frame - 126"		1					
1	0508	Assy. Gang Frame - 144"			1				
1	0487	Assy. Gang Frame - 165"				1			
1	0519	Assy. Gang Frame - 187"					1		
1	0493	Assy. Gang Frame - 209"						1	
1	0516	Assy. Gang Frame - 228"							1
2	11522	Shock Absorber Shank	3	4	5	6	6	6	8
5	11647	Flange Lock Nut 5/8 NC, PL	12	16	18	21	23	26	29
6	10665	Carriage Bolt 5/8 x 2 NC, PL, Gr. 5	3	5	5	6	6	7	8
7	10135	Carriage Bolt 5/8 x 1-3/4 NC, PL, Gr. 5	15	19	23	27	29	31	37
8	10299	Lock Nut 5/8 NC, PL	6	8	10	12	12	12	16
9	9212	U-Bolt 3/4 Dia.		1					1
10	10300	Lock Nut 3/4 NC, PL	3	6	5	6	6	8	8
11	100969	Support		1				1	
12	9455	Gang Bolt 1-1/2 Sq. - 103-1/4 - 10 Blade	1					2	
12	9450	Gang Bolt 1-1/2 Sq. - 49-1/2 - 5 Blade		1					
12	9444	Gang Bolt 1-1/2 Sq. - 70-5/8 - 7 Blade		1					
12	9451	Gang Bolt 1-1/2 Sq. - 60-1/4 - 6 Blade			1				1
12	9453	Gang Bolt 1-1/2 Sq. - 81-3/4 - 8 Blade			1	2			2
12	9454	Gang Bolt 1-1/2 Sq. - 92-1/2 - 9 Blade					2		
13	10910	Roll Pin 5/16 x 2-1/4	1	2	2	2	2	2	3
14	20620	Grease Guard	3	4	5	6	6	6	8
14A	102541	Wear Guard	3	4	5	6	6	6	8
15	10226	Nut Gang Bolt 1-1/2 NF, Slotted	1	2	2	2	2	2	3
16	10872	Cut Washer 1-3/8 PL	1	2	2	2	2	2	3
17	100738	Bumper Washer	1	2	2	2	2	2	3
18	3276	Blade 22 x 1/4 PL	2	2	2	2	2	2	2
18	3275	Blade 22 x 1/4 C.O	2	2	2	2	2	2	2
18	3255	Blade 22 x 1/4 PL	2	2	2	2	2	2	2
18	3250	Blade 24 x 1/4 C.O	2	2	2	2	2	2	2
19	17004	End Bell - Small	3	4	5	6	6	6	8
20	FB-09-0016	Sub. Assy. Bearing & Housing	3	4	5	6	6	6	8
A	16014	Bearing - Housing	1	1	1	1	1	1	1
B	11504	Bearing (DC214TTR3)	1	1	1	1	1	1	1
C	100105	Washer 125mm	2	2	2	2	2	2	2
D	11072	Retainer Ring	1	1	1	1	1	1	1
E	12384	Grease Fitting 1/8 NPT	1	1	1	1	1	1	1
21	17005	End Bell - Large	3	4	5	6	6	6	8
22	0947	Spacer Spool	6	6	7	8	10	12	11
22A	0946	Spacer Spool (for J43 with Back-up Blades)	6	6	7	8	10	12	11
23	1222A	End Gang Washer	1	2	2	2	2	2	3
24	100099	Spacer Plate	1	2	2	2	2	2	3
25	100098	Bearing Plate	1	2	2	2	2	2	3
26	5622A	Lock Plate	1	2	2	2	2	2	3
27	10489	Nut Gang Bolt 1-1/2 NF	1	2	2	2	2	2	3
28	10710	Carriage Bolt 1/2 x 2 NC, PL, Gr. 5	1	2	2	2	2	2	3
29	10395	Lock Nut 1/2 NC, PL	1	2	2	2	2	2	3
30	101052	Scraper Bar 3 x 2 x 3/8 - 101-11/16	1					2	
30	101070	Scraper Bar 3 x 2 x 3/8 - 123-1/16		1					
30	101103	Scraper Bar 3 x 2 x 3/8 - 5-15/16			1				1
30	101050	Scraper Bar 3 x 2 x 3/8 - 80-5/16			1	2			2
30	101051	Scraper Bar 3 x 2 x 3/8 - 91					2		
31	20068	Assy. Scraper - RH	9	11	13	15	17	19	21
A	101049	Scraper Shank	1	1	1	1	1	1	1
B	101019	Scraper Blade	1	1	1	1	1	1	1
C	11652	Machine Bolt (black) 1/2 x 1-1/4 NC, Gr.5	2	2	2	2	2	2	2
D	10395	Lock Nut 1/2 NC, PL	2	2	2	2	2	2	2
33	3255	Blade 24 x 1/4 PL	8	10	12	14	16	18	20
33	3263	Blade 26 x 1/4 PL	8	10	12	14	16	18	20
33	11576	Blade 26 x 5/16 PL	8	10	12	14	16	18	20
34	3250	Blade 24 x 1/4 C.O.	8	10	12	14	16	18	20
34	2456	Blade 26 x 1/4 C.O.	8	10	12	14	16	18	20
34	11575	Blade 26 x 5/16 C.O.	8	10	12	14	16	18	20
35	3278	Blade 10 x 11 Ga. PL Back-up	1	1	1	1	1	1	1
35	3278	Blade 10 x 11 Ga. PL Back-ups for every blade	10	12	14	16	18	20	22
36	100886	Sleeve	3	4	5	6	6	6	8





AMCO									
J43									
REAR GANG & FRAME									
Ref. No.	Part No.	Description	No. Req'd. Blades						
			22	24	28	32	36	40	44
1	0503	Assy. Gang Frame - 102"	1						
1	0506	Assy. Gang Frame - 126"		1					
1	0508	Assy. Gang Frame - 144"			1				
1	0487	Assy. Gang Frame - 165"				1			
1	0519	Assy. Gang Frame - 187"					1		
1	0493	Assy. Gang Frame - 209"						1	
1	0516	Assy. Gang Frame - 228"							1
2	11522	Shock Absorber Shank	3	4	5	6	6	6	8
5	11647	Flange Lock Nut 5/8 NC, PL	12	16	18	21	23	26	29
6	10665	Carriage Bolt 5/8 x 2 NC, PL, Gr. 5	3	5	5	6	6	7	8
7	10135	Carriage Bolt 5/8 x 1-3/4 NC, PL, Gr. 5	15	19	23	27	29	31	37
8	10299	Lock Nut 5/8 NC, PL	6	8	10	12	12	12	16
9	9212	U-Bolt 3/4 Dia.		1				1	
10	10300	Lock Nut 3/4 NC, PL		2				2	
11	100969	Support		1				1	
12	9455	Gang Bolt 1-1/2 Sq. - 103-1/4 - 10 Blade	1					2	
12	9450	Gang Bolt 1-1/2 Sq. - 49-1/2 - 5 Blade		1					
12	9444	Gang Bolt 1-1/2 Sq. - 70-5/8 - 7 Blade		1					
12	9451	Gang Bolt 1-1/2 Sq. - 60-1/4 - 6 Blade			1				1
12	9453	Gang Bolt 1-1/2 Sq. - 81-3/4 - 8 Blade			1	2			2
12	9454	Gang Bolt 1-1/2 Sq. - 92-1/2 - 9 Blade					2		
13	10910	Roll Pin 5/16 x 1/4	1	2	2	2	2	2	3
14	20620	Grease Guard	3	4	5	6	6	6	8
14A	102541	Wear Guard	3	4	5	6	6	6	8
15	10226	Nut Gang Bolt 1-1/2 NF, Slotted	1	2	2	2	2	2	3
16	10872	Cut Washer 1-3/8 PL	1	2	2	2	2	2	3
17	100738	Bumper Washer	1	1	1	1	1	1	2
17A	100738A	Bumper Washer (Drilled & Tapped)	1	1	1	1	1	1	1
18	3276	Blade 22 x 1/4 PL	1	1	1	1	1	1	1
18	3275	Blade 22 x 1/4 C.O.	1	1	1	1	1	1	1
18	3255	Blade 24 x 1/4 PL	1	1	1	1	1	1	1
18	3250	Blade 24 x 1/4 C.O.	1	1	1	1	1	1	1
19	17004	End Bell - Small	3	4	5	6	6	6	8
20	FB-09-0016	Sub. Assy. Bearing & Housing	3	4	5	6	6	6	8
A	10614	Bearing - Housing	1	1	1	1	1	1	1
B	11504	Bearing (DC214TTR3)	1	1	1	1	1	1	1
C	100105	Washer 125mm	2	2	2	2	2	2	2
D	11072	Retainer Ring	1	1	1	1	1	1	1
E	12384	Grease Fitting 1/8 NPT	1	1	1	1	1	1	1
21	17005	End Bell - Large	3	4	5	6	6	6	8
22	0947	Spacer Spool	6	6	7	8	10	12	11
22A	0946	Spacer Spool (for J43 with Buck-up Blades)	6	6	7	8	10	12	11
23	1222A	End Gang Washer	1	2	2	2	2	2	3
24	100099	Spacer Plate	1	2	2	2	2	2	3
25	100098	Bearing Plate	1	2	2	2	2	2	3
26	5622A	Lock Plate	1	2	2	2	2	2	3
27	10489	Nut Gang Bolt 1-1/2 NF, Slotted	1	2	2	2	2	2	3
28	10710	Carriage Bolt 1/2 x 2 NC, PL, GR. 5	1	2	2	2	2	2	3
29	10395	Lock Nut 1/2 NC, PL	1	2	2	2	2	2	3
30	101052	Scraper Bar 3 x 2 x 3/8 - 101-11/16	1					2	
30	101070	Scraper Bar 3 x 2 x 3/8 - 123-1/16		1					
30	101103	Scraper Bar 3 x 2 x 3/8 - 5/8-15/16			1				1
30	101050	Scraper Bar 3 x 2 x 3/8 - 80-5/16			1	2			2
30	101051	Scraper Bar 3 x 2 x 3/8 - 91					2		
31	20069	Assy. Scraper - LH	9	11	13	15	17	19	21
A	101049	Scraper Shank	1	1	1	1	1	1	1
B	101019	Scraper Blade	1	1	1	1	1	1	1
C	11652	Machine Bolt (black) 1/2 x 1-1/4 NC, Gr. 5	2	2	2	2	2	2	2
D	10395	Lock Nut 1/2 NC, PL	2	2	2	2	2	2	2
33	3255	Blade 24 x 1/4 PL	8	10	12	14	16	18	20
33	3263	Blade 26 x 1/4 PL	8	10	12	14	16	18	20
33	11576	Blade 26 x 5/16 PL	8	10	12	14	16	18	20
34	3250	Blade 24 x 1/4 C.O.	8	10	12	14	16	18	20
34	2456	Blade 26 x 1/4 C.O.	8	10	12	14	16	18	20
34	11575	Blade 26 5/16 C.O.	8	10	12	14	16	18	20
35	11588	Blade 20 x 1/4 PL	1	1	1	1	1	1	1
35	11589	Blade 20 x 1/4 C.O.	1	1	1	1	1	1	1
35	3276	Blade 22 x 1/4 PL	1	1	1	1	1	1	1
35	3275	Blade 22 x 1/4 C.O.	1	1	1	1	1	1	1
36	100886	Sleeve	3	4	5	6	6	6	8
37	3278	Blade 10 x 11 Ga. PL Back-up (for models with Back-ups for every Blade)	10	12	14	16	18	20	22

# J44 FRONT GANG & FRAME

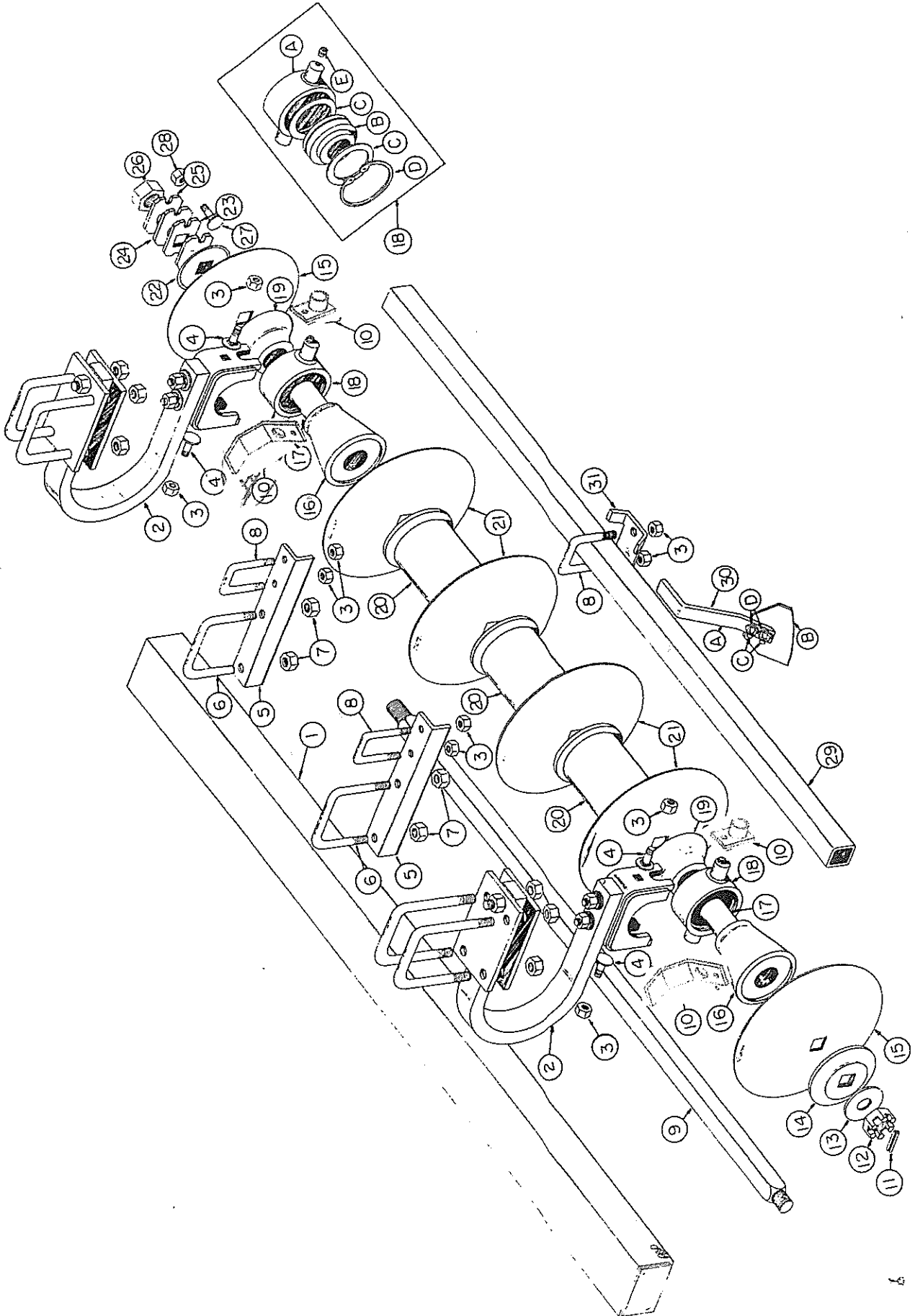

AMCO									
J44									
FRONT GANG & FRAME									
Ref. No.	Part No.	Description	No.						
			22	24	28	32	36	40	44
		Req'd.		Blades					
1	0503	Assy. Gang Frame - 102"	1						
1	0506	Assy. Gang Frame - 126"		1					
1	0508	Assy. Gang Frame - 144"			1				
1	0487	Assy. Gang Frame - 165"				1			
1	0519	Assy. Gang Frame - 187"					1		
1	0493	Assy. Gang Frame - 209"						1	
1	0516	Assy. Gang Frame - 228"							1
2	11522	Shock Absorber Shank	3	4	5	6	6	8	8
3	10299	Lock Nut 5/8 NC, PL	30	38	44	52	56	66	70
4	10135	Carriage Bolt 5/8 x 1-3/4 NC, PL, Gr. 5	6	8	10	12	12	16	16
5	100722	Scaper Bar Support	3	4	4	5	5	6	6
6	9212	U-bolt 3/4 Dia.	3	4	4	5	5	6	6
7	10300	Lock Nut 3/4 NC, PL	6	8	8	10	10	12	12
8	100002A	U-bolt 5/8 Dia.	12	15	17	20	22	25	27
9	9450	Gang bolt 1-1/2 Sq. - 49-1/2 - 5 Blade		1		2		4	2
9	9455	Gang Bolt 1-1/2 Sq. - 103-1/4 - 10 Blade	1						
9	9444	Gang Bolt 1-1/2 Sq. - 70-5/8 - 7 Blade		1					
9	9451	Gang Bolt 1-1/2 Sq. - 60-1/4 - 6 Blade			1	1	3		2
9	9453	Gang Bolt 1-1/2 Sq. - 81-3/4 - 8 Blade			1				
10	20620	Trunnion Clamp	3	4	5	6	6	8	8
10A	102541	Wear Guard	3	4	5	6	6	8	8
11	10910	Roll Pin 5/16 x 2-1/4	1	2	2	2	3	4	4
12	10226	Nut Gang Bolt 1-1/2 NF, Slotted	1	2	2	2	3	4	4
13	10872	Cut Washer 1-3/8 PL	1	2	2	2	3	4	4
14	100738	Bumper Washer	1	2	2	3	3	4	4
15	3276	Blade 22 x 1/4 PL	2	2	2	2	2	2	2
15	3275	Blade 22 x 1/4 C.O.	2	2	2	2	2	2	2
15	3255	Blade 22 x 1/4 PL	2	2	2	2	2	2	2
15	3250	Blade 24 x 1/4 C.O.	2	2	2	2	2	2	2
16	17004	End Bell- Small	3	4	5	6	6	8	8
17	100886	Sleeve	3	4	5	6	6	8	8
18	FB-09-0016	Sub. Assy. Bearing & Housing	3	4	5	6	6	8	8
A	16014	Bearing - Housing	1	1	1	1	1	1	1
B	11504	Bearing (DC214TTR3)	1	1	1	1	1	1	1
C	100105	Washer 125mm	2	2	2	2	2	2	2
D	11072	Retainer Ring	1	1	1	1	1	1	1
E	12384	Grease Fitting 1/8 NPT	1	1	1	1	1	1	1
19	17005	End Bell - Large	3	4	5	6	6	8	8
20	0946	Spacer Spool	6	6	7	7	9	8	10
21	3255	Blade 24 x 1/4 PL	8	10	12	14	16	18	20
21	3250	Blade 24 x 1/4 C.O.	8	10	12	14	16	18	20
21	3263	Blade 26 x 1/4 PL	8	10	12	14	16	18	20
21	2456	Blade 26 x 1/4 C.O.	8	10	12	14	16	18	20
21	11576	Blade 26 x 5/16 PL	8	10	12	14	16	18	20
21	11575	Blade 26 x 5/16 C.O.	8	10	12	14	16	18	20
22	1222A	End Gang Washer	1	2	2	2	3	4	4
23	100099	Spacer Plate	1	2	2	2	3	4	4
24	100098	Bearing Plate	1	2	2	2	3	4	4
25	5622A	Lock Plate	1	2	2	2	3	4	4
26	10489	Nut Gang Bolt 1-1/2 NF	1	2	2	2	3	4	4
27	10710	Carriage Bolt 1/2 x 2 NC, PL, Gr. 5	1	2	2	2	3	4	4
28	10395	Lock Nut 1/2 NC, PL	1	2	2	2	3	4	4
29	100010	Scraper Bar 2-1/2 x 2-1/2 x 1/4 WT - 102"	1						
29	100013	Scraper Bar 2-1/2 x 2-1/2 x 1/4 WT - 126"		1					
29	100015	Scraper Bar 2-1/2 x 2-1/2 x 1/4 WT - 144"			1				
29	100016	Scraper Bar 2-1/2 x 2-1/2 x 1/4 WT - 165"				1			
29	100018	Scraper Bar 2-1/2 x 2-1/2 x 1/4 WT - 187"					1		
29	100020	Scraper Bar 2-1/2 x 2-1/2 x 1/4 WT - 209"						1	
29	100021	Scraper Bar 2-1/2 x 2-1/2 x 1/4 WT - 228"							1
30	20072	Assy. Scraper - RH	9	11	13	15	17	19	21
A	100987	Scraper Shank	1	1	1	1	1	1	1
B	101019	Scraper Blade	1	1	1	1	1	1	1
C	11652	Machine Bolt (black) 1/2 x 1-1/4 NC, Gr. 5	2	2	2	2	2	2	2
D	10395	Lock Nut 1/2 NC, PL	9	11	13	15	17	19	21
31	101055	Clamp Bracket	9	11	13	15	17	19	21
32	3278	Blade 10 x 11 Ga. PL Back-up	10	12	14	16	18	20	22

# J44 REAR GANG & FRAME

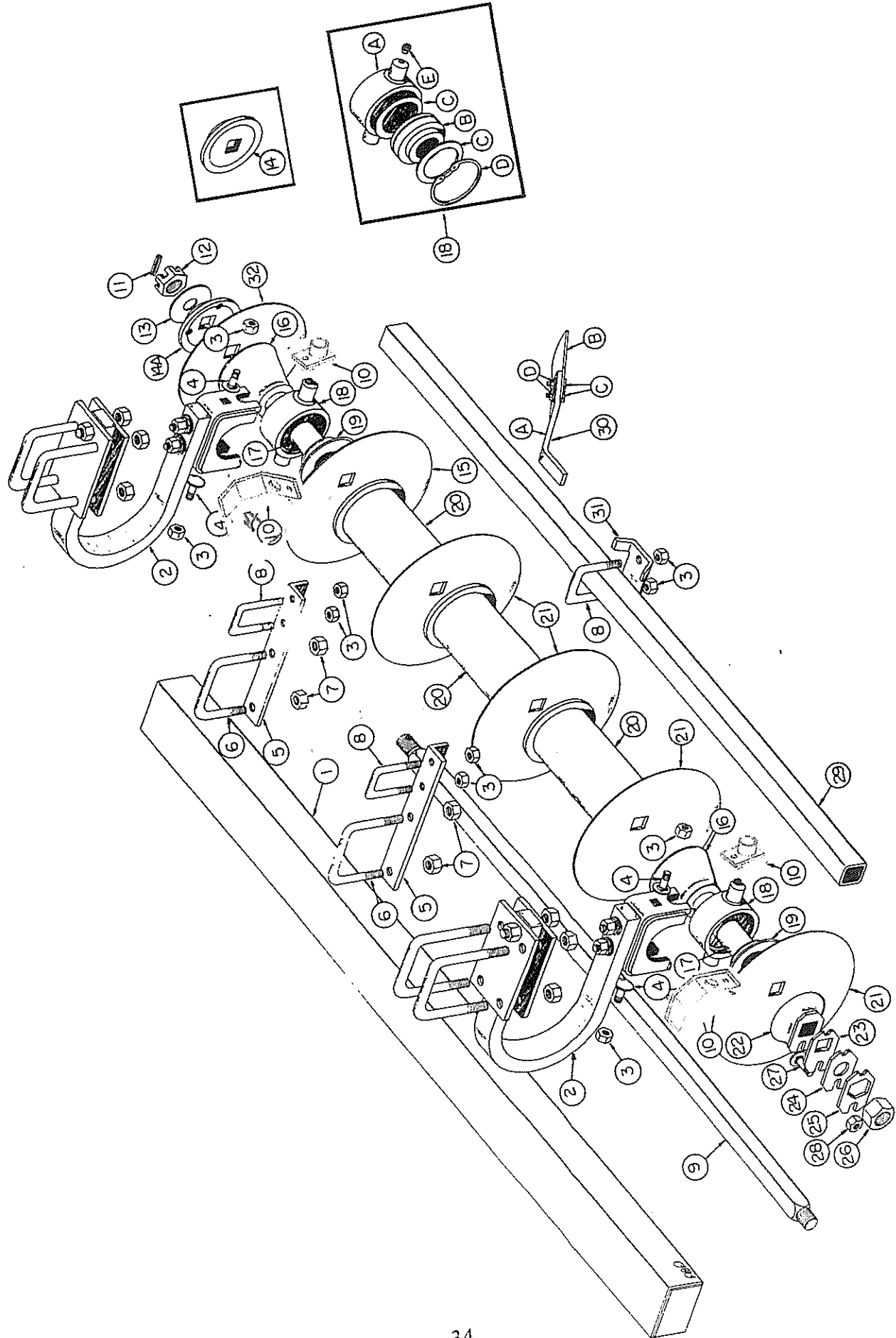

AMCO									
J44									
REAR GANG & FRAME									
Ref. No.	Part No.	Description	No. Req'd. Blades						
			22	24	28	32	36	40	44
1	0503	Assy. Gang Frame - 102"	1						
1	0506	Assy. Gang Frame - 126"		1					
1	0508	Assy. Gang Frame - 144"			1				
1	0487	Assy. Gang Frame - 165"				1			
1	0519	Assy. Gang Frame - 187"					1		
1	0493	Assy. Gang Frame - 209"						1	
1	0516	Assy. Gang Frame - 228"							1
2	11522	Shock Absorber Shank	3	4	5	6	6	8	8
3	10299	Lock Nut 5/8 NC, PL	30	38	44	52	56	66	70
4	10135	Carriage Bolt 5/8 x 1-3/4 NC, PLT, GR. 5	6	8	10	12	12	16	16
5	100722	Scarper Bar Support	3	4	4	5	5	6	6
6	9212	U-bolt 3/4 Dia.	3	4	4	5	5	6	6
7	10300	Lock Nut - 3/4 NC, PL	6	8	8	10	10	12	12
8	100002A	U-bolt 5/8 Dia	12	15	17	20	22	25	27
9	9450	Gang Bolt 1-1/2 Sq. - 49-1/2 - 5 Blade		1		2		4	2
9	9444	Gang Bolt 1-1/2 Sq. 70-5/8 - 7 Blade		1					
9	9451	Gang Bolt 1-1/2 Sq. 60-1/4 - 6 Blade			1	1	3		2
9	9453	Gang Bolt 1-1/2 Sq. 81-3/4 - 8 Blade			1				
9	9455	Gang Bolt 1-1/2 Sq. 103-1/4 - 10 Blade	1						
10	20620	Trunnion Clamp	3	4	5	6	6	8	8
10A	102541	Wear Guard	3	4	5	6	6	8	8
11	10910	Roll Pin 5/16 x 2-1/4	2	2	2	3	3	4	4
12	10226	Nut Gang Bolt 1-1/2 NF, Slotted	2	2	2	3	3	4	4
13	10872	Cut Washer 1-3/8 NF, Slotted	2	2	2	3	3	4	4
14	100738	Bumper Washer	1	1	1	2	2	3	3
14A	100738A	Bumper Washer (Drilled & Tapped)	1	1	1	1	1	1	1
15	3276	Blade 22 x 1/4 PL	1	1	1	1	1	1	1
15	3275	Blade 22 x 1/4 C.O.	1	1	1	1	1	1	1
15	3255	Blade 24 x 1/4 PL	1	1	1	1	1	1	1
15	3250	Blade 24 x 1/4 C.O.	1	1	1	1	1	1	1
16	17004	End Bell - Small	3	4	5	6	6	8	8
17	100886	Sleeve	3	4	5	6	6	8	8
18	FB-09-0016	Sub. Assy. Bearing & Housing	3	4	5	6	6	8	8
A	16014	Bearing - Housing	1	1	1	1	1	1	1
B	11504	Bearing (DC214TTR3)	1	1	1	1	1	1	1
C	100105	Washer 125mm	2	2	2	2	2	2	2
D	11072	Retainer Ring	1	1	1	1	1	1	1
E	12384	Grease Fitting NPT 45	1	1	1	1	1	1	1
19	17005	End Bell - Large	3	4	5	6	6	8	8
20	0946	Spacer Spool	6	6	7	7	9	8	10
21	3255	Blade 24 x 1/4 PL	8	10	12	14	16	18	20
21	3250	Blade 24 x 1/4 C.O.	8	10	12	14	16	18	20
21	3263	Blade 26 x 1/4 PL	8	10	12	14	16	18	20
21	2456	Blade 26 x 1/4 C.O.	8	10	12	14	16	18	20
21	11576	Blade 26 x 5/16 PL	8	10	12	14	16	18	20
21	11575	Blade 26 x 5/16 C.O.	8	10	12	14	16	18	20
22	1222A	End Gang Washer	2	2	2	3	3	4	4
23	100099	Spacer Plate	2	2	2	3	3	4	4
24	100098	Bearing Plate	2	2	2	3	3	4	4
25	5622A	Lock Plate	2	2	2	3	3	4	4
26	10489	Nut Gang Bolt 1-1/2 NF	2	2	2	3	3	4	4
27	10710	Carriage Bolt 1/2 x 2 NC, PL, Gr. 5	2	2	2	3	3	4	4
28	10395	Lock Nut 1/2 NC, PL	2	2	2	3	3	4	4
29	100010	Scraper Bar 2-1/2 x 2-1/2 x 1/4 WT - 102"	1						
29	100013	Scraper Bar 2-1/2 x 2-1/2 x 1/4 WT - 126"		1					
29	100015	Scraper Bar 2-1/2 x 2-1/2 x 1/4 WT - 144"			1				
29	100016	Scraper Bar 2-1/2 x 2-1/2 x 1/4 WT - 165"				1			
29	100018	Scraper Bar 2-1/2 x 2-1/2 x 1/4 WT - 187"					1		
29	100020	Scraper Bar 2-1/2 x 2-1/2 x 1/4 WT - 209"						1	
29	100021	Scraper Bar 2-1/2 x 2-1/2 x 1/4 WT - 228"							1
30	20073	Assy. Scraper - LH	9	11	13	15	17	19	21
A	100987	Scraper Shank	1	1	1	1	1	1	1
B	101019	Scraper Blade	1	1	1	1	1	1	1
C	11652	Machine Bolt (black) 1/2 x 1-1/4 NC, GR. 5	2	2	2	2	2	2	2
D	10395	Lock Nut 1/2 NC, PL	2	2	2	2	2	2	2
31	101055	Clamp Bracket	9	11	13	15	17	19	21
32	3278	Blade 10 x 11 Ga. PL - Back-up	10	12	14	16	18	20	22



<b>AMCO</b>			
<b>J43 SHOCK ABSORBER BEARING RISER</b>			
<b>OPTIONAL F42 &amp; J42 ABSORBER</b>			
<b>BEARING RISER</b>			
<u>Ref. No.</u>	<u>Part No.</u>	<u>Description</u>	<u>No. Req'd.</u>
A	101057	Upper Clamp Plate	1
B	101056	Lower Clamp Plate	1
C	101054	U-bolt - 7/8 Dia.	2
D	11522	Shock Absorber Shank	1
E	0944	Trunnion Mount Assy. (F42 & J42 only)	1
*E	0945	Trunnion Mount Assy. (J43 only)	1
F	10320	Hex Bolt - 3/4 x 3-1/2 NC, PL	1
G	10300	Lock Nut - 3/4 NC, PL	2
H	10396	Lock Nut - 7/8 NC, PL	2
J	10579	Carriage Bolt - 3/4 x 3 NC, PLT, Gr. 5	2
K	12069	Flange Lock Nut - 3/4 NC, PLT	2
		NOTE: Use Part #20312 Trunnion Mount with 28" Blades instead of Part #0945 Mount with the J43 only.	

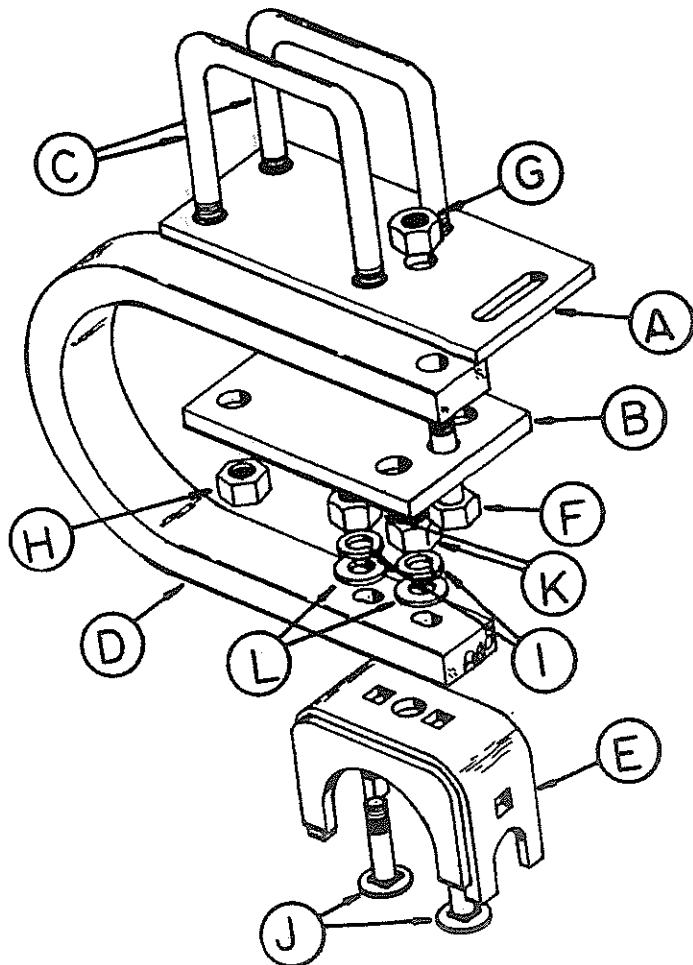

<b>AMCO</b>			
<b>J44</b>			
<b>SHOCK ABSORBER BEARING RISER</b>			
<u>Ref. No.</u>	<u>Part No.</u>	<u>Description</u>	<u>No. Req'd.</u>
A	101058	Upper Clamp Plate	1
B	101056	Lower Clamp Plate	1
C	101054	U-bolt 7/8 Dia.	2
D	11522	Shock Absorber Shank	1
*E	0945	Trunnion Mount Assy.	1
F	10320	Hex Bolt - 3/4 x 3-1/2 NC, PL, Gr. 5	1
G	10300	Lock Nut - 3/4 NC, PL	1
H	10396	Lock Nut - 7/8 NC, PL	2
J	10579	Carriage Bolt - 3/4 x 3 NC, PLT, Gr. 5	2
K	12069	Flange Lock Nut - 3/4 NC, PLT	2
NOTE: Use Part #20312 Trunnion Mount with 28" Bladed instead of Part #0945 Mount.			

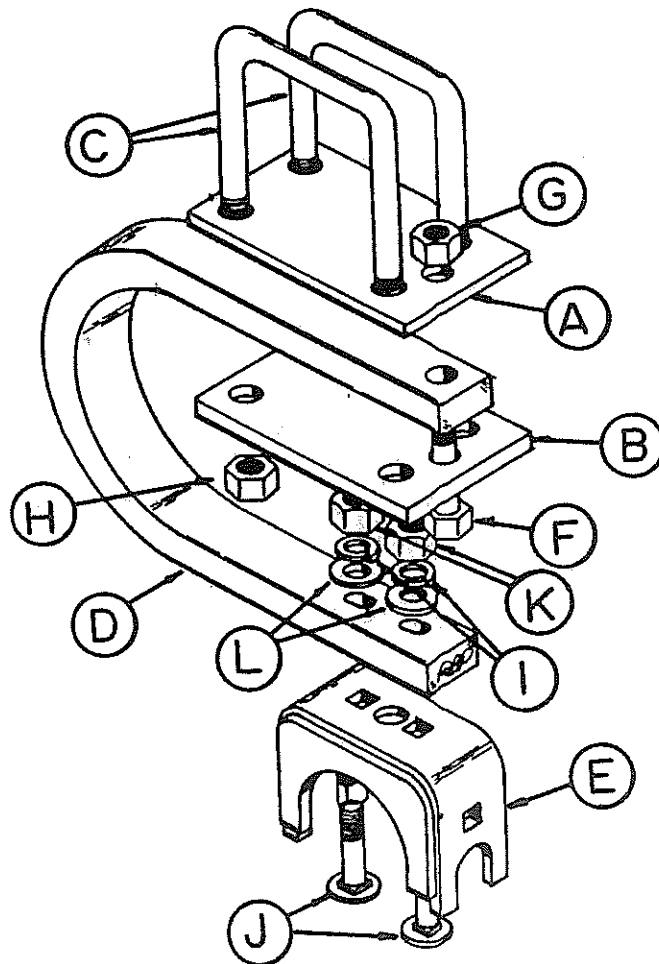



# DECALS

①



②



③

MAINTENANCE INSTRUCTIONS	
<p>1. Keep all bolts tight.</p> <p>A. Visually inspect all bolts daily.</p> <p>B. Check after first 50 hours or one week's operations.</p>	<p>3. Do not run with loose disk blades. Keep gang bolts tight! Tighten after first day's operation.</p>
<p>2. Keep wheel bearings properly adjusted.</p> <p>A. Clean and repack each season or every 300 hours.</p> <p>B. Replace all worn or damaged parts when repairing.</p>	<p>4. Keep scrapers properly adjusted 1/16" - 1/8" from blades.</p> <p>5. Grease gang bearings every week or 50 hours, at the start of each season, and at the end of each season. Apply with low pressure, low volume hand grease gun. Use a good, clean lithium base grease, Shell Alvania No. 3 or equal. Rotate gangs while greasing for best results.</p>

AMCO			
F42**J42**J43**J44			
DECALS			
Ref. No.	Part No.	Description	No. Req'd.
1	11465	Decal - AMCO	3
2	11741	Decal - Warning	1
3	11716	Decal - Maintenance	1
	12540	Reflector- Orange Strips	2
	12541	Reflector - Red Strips	2
	11902	Decal Model (specify model & size when ordering)	

# assembly instructions

## Amco F42, J42, J43, J44

The harrow is shipped from the factory with maximum pre-assembly in the following bundles:

- A. Main Frame and Rockshaft
- B. Pull Tongue
- C. Two Gangs and Frame bundles with scrapers and scraper bar attached.
- D. Four 15 x 8 six bolt wheels
- E. Auxiliary frames on models 16'6" and larger

1. Place all bundles where they will be convenient. Arrange loose parts so they may be readily seen when needed. To insure good alignment of the units and parts, always insert all bolts leaving the nuts loose. Tighten the nuts evenly to prevent misalignment, distortion, or binding. Be sure all bolts are tight, all cotter pins properly spread and all pins properly inserted.

2. Select clean level area for assembly. Place main frame on sturdy stands at least 30" high. Place on front and rear to clear gang frames.



**CAUTION:** *Use sturdy stands to prevent frame from falling.*

- 3. Attach pull tongue using holes in the main frame. Tighten bolts.
- 4. Attach stabilizer to the control bracket on the main frame and to the pull tongue.
- 5. Attach hose holder to pull tongue.

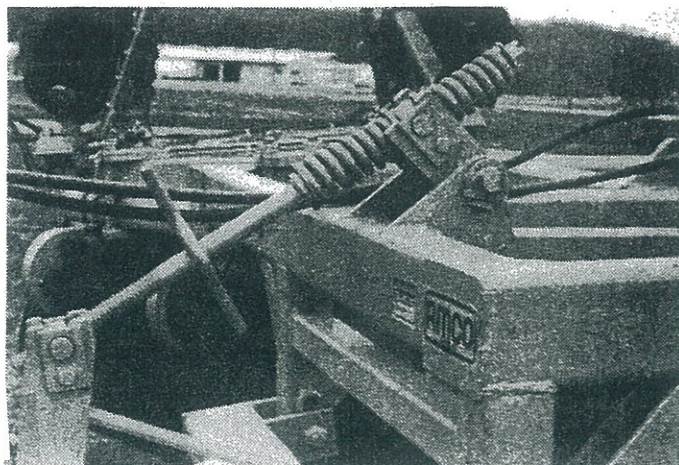
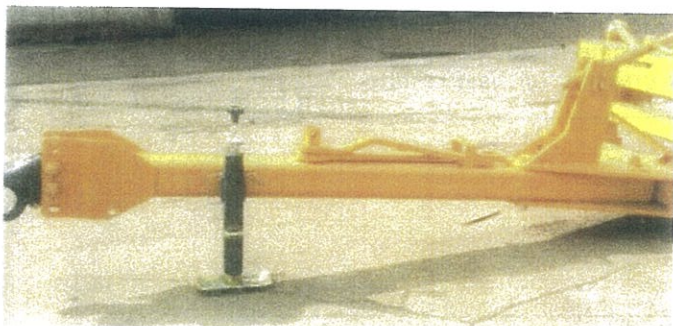

6. Attach tongue jack to pull tongue.
7. Mount the spindles and hubs on the rockshaft legs. Insert proper bolts and tighten. (Refer to page 7 for proper torque.)
8. Mount tires and tubes on 15 x 8 wheels. Inflate tires. 9.5L x 15 or 11L x 15, 6 & 8 ply recommended. Bolt the wheels to the hubs. Tighten hub bolts evenly to assure wheel alignment.
9. Install a 4 x 8 or 4 x 16 hydraulic cylinder to the harrow. Connect hydraulic hoses from the cylinder to the tractor. Attach the clevis to the drawbar.
10. Raise the harrow up on the wheels by activating the hydraulic cylinder.
11. Remove gang clamp plates and gang frame clamps from the main frame. Attach the gang assemblies to the main frame. Secure them with clamp plates and gang frame clamps. The convex end of the gang frame clamps should be placed behind the rod of the clamp plates on the right hand side of the harrow. Some of the larger models will also have gang frame clamps attached to the gang frame. The convex end should face the main frame. One should be placed on the right front gang frame against the outside of the main frame; the other on the right rear gang on the inside of the main frame. (Refer to the drawing on page 51 for correct placement of all gang clamps.)
12. Tighten bolts snug but not tight. For proper placement of the gang frame on the main frame, refer to the charts and drawings beginning with page 51.
13. On models 16'6" and up, attach the two auxiliary frames to the gang frames.

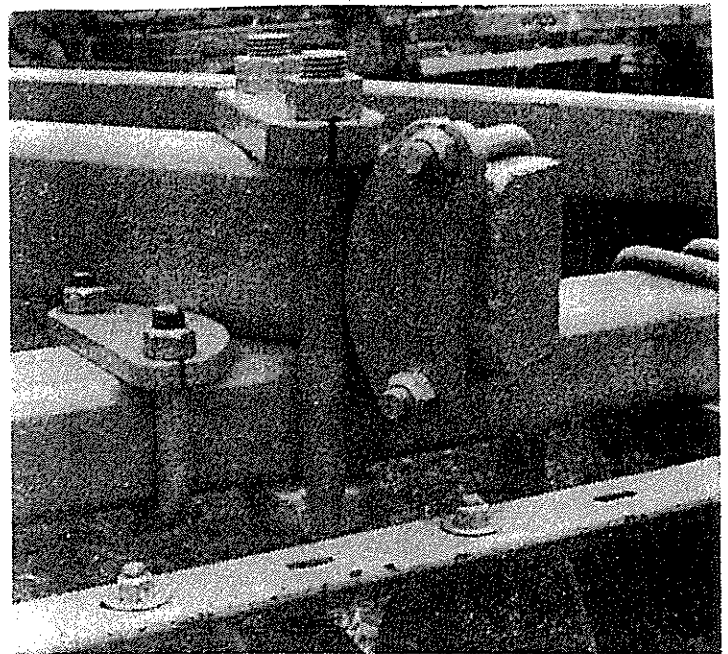
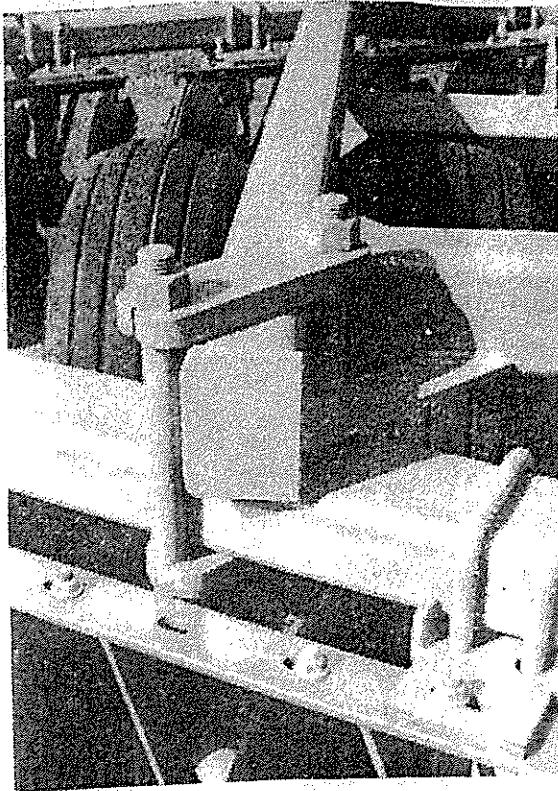

14. Check and tighten all bolts. Be sure all cotter pins are properly spread and all pins in place. Check the gangs to see that they rotate freely.
15. Be sure that the harrow is properly lubricated.
16. Adjust the harrow for front to rear leveling.

# *lubrication*

Careful and regular attention to lubrication will greatly increase the life of the harrow. For economical and efficient operation, the proper lubrication of the gang bearing, rockshaft retainer pins, wheel bearings and stabilizer is essential.

Be sure the pressure fittings are free of dirt or paint before using the pressure gun. Replace any damaged or missing fitting. Use good grade No. 2 grease (Lithium Base). Never use greases which contain metallic additives. Always make sure that grease is clean and not contaminated with dirt or other foreign matter.

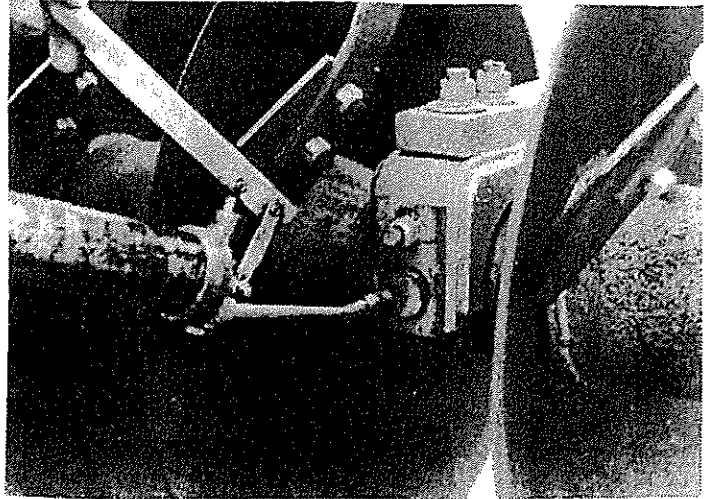

The gangs are equipped with ball bearings, which are greased at the factory. They should be greased every week or 50 hours of operation. These bearings must also be greased at the start of each season, and at the end of each season.

Protect-O-Shield bearings should be greased until grease “pops” out around the bearings. The bearing will thus be purged of any dirt or foreign matter. The Protect-O-Shield prevents any possibility of blown seals.

Grease rockshaft retainer pins each week or 50 hours of operation. These retainer pins should also be greased at the start of each season and at the end of each season. Bushings should be checked each season and replaced when worn.

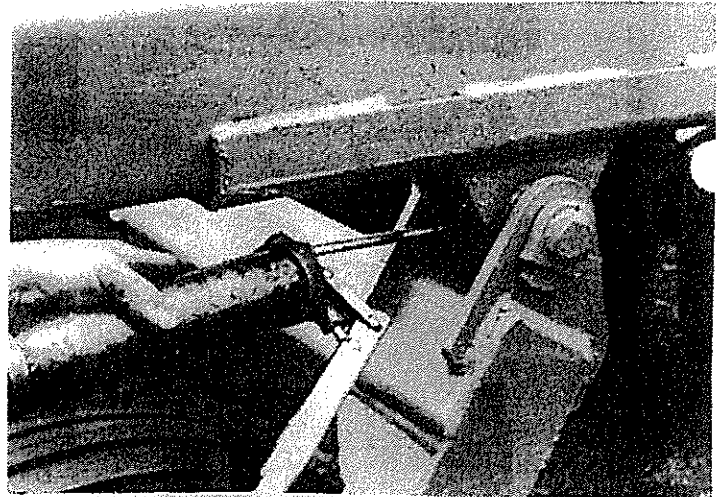

Grease cylinder mount pins and depth stop each week or 50 hours of operation.

Wheel bearings should be repacked with grease and adjusted annually. Under extreme conditions, they should be serviced more frequently. Check occasionally for excessive end play. Adjust as required to eliminate excessive end play.

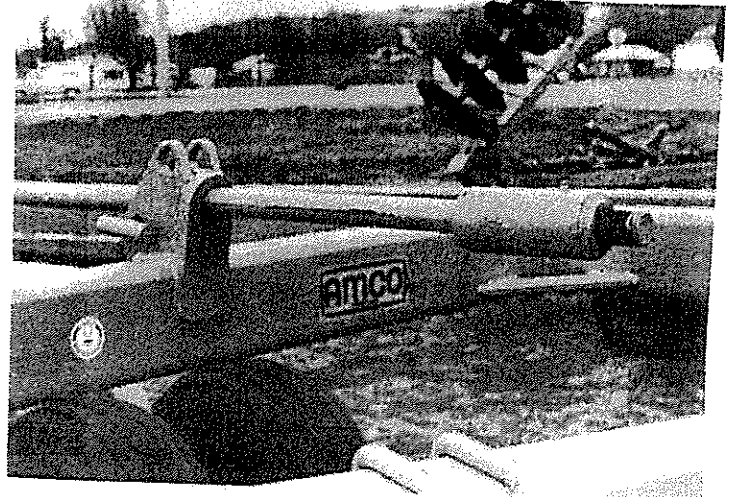



# *operating instructions*

Your new AMCO offset disk harrow has been set-up, inspected, and adjusted by your dealer before delivery. However, before using your new harrow, or one that has been stored, check to make certain that all nuts and bolts are tight, all cotter pins spread and that the harrow has been lubricated.

This instruction manual should be carefully and thoroughly read to enable the operator to care for and operate the harrow.

The right and left hand sides of the harrow are determined by standing at the rear of the harrow and facing the direction of travel.

Refer to your tractor operator's manual for complete tractor operating instructions.

**ADJUSTMENT FOR LEVEL DISKING:** It is recommended that the tractor be operated at a speed best suited for soil conditions. High-speed disking may require different adjustments than disking at normal speeds. Under some conditions high speeds may cause "ridging" or "furlowing."

When disking in a cover crop or where the land is to be reworked, an uneven surface is not objectionable. If the land is to be bare through the winter, furrows and ridges will reduce soil washing and will help catch and hold moisture, resulting in more water being absorbed by the soil.

**FEATHERING BLADES:** The use of feathering blades with smaller disks will move the excess soil back which is thrown out by the front gangs at high speeds. By using the feathering blades, the outside furrows are partially filled, giving a more uniform job of disking.

**GROUND SPEED AND ADJUSTMENTS:** Where it is necessary to have a level job of disking, the following factors must be taken into consideration: (1) Tractor Speed (2) Hitch Adjustment (3) Disk Gang Angle Adjustment.

**TRACTOR DRAWBAR:** It is suggested that the tractor drawbar be set so it is free to swing when disking. This will prevent side draft, making operation of the harrow easier. The tractor drawbar will pull somewhat to the left side during operation.

**HARROW HITCH:** The harrow pull tongue can be offset to the right or left by using the set of holes in the cross tongue plates to obtain the desired offset.

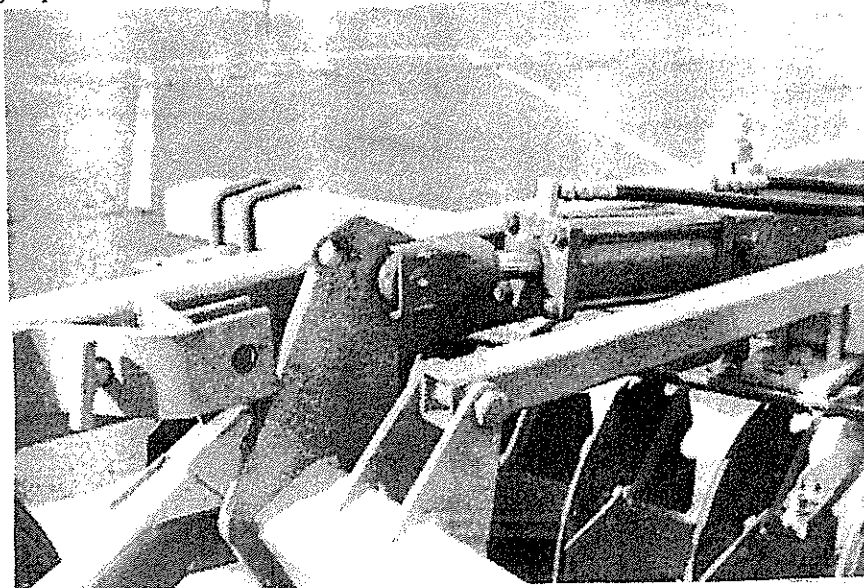

**TRANSPORT PIN:** When transporting the disk harrow, always lock it in transport position with the transport pin. If the hydraulic cylinder is to be removed from the disk harrow, the transport pin should be installed before attempting to remove the cylinder.

## SPRING LOADED STABILIZER

Penetration of the front and rear gangs may vary. The spring loaded stabilizer may be adjusted to level the harrow front to rear. In extremely hard ground it may be necessary to shorten the stabilizer to force the front or penetrating gang into the ground. In normal conditions, the stabilizer should be adjusted so that the disk harrow is level front to rear while disking. The stabilizer may also be adjusted to level the unit for transport.

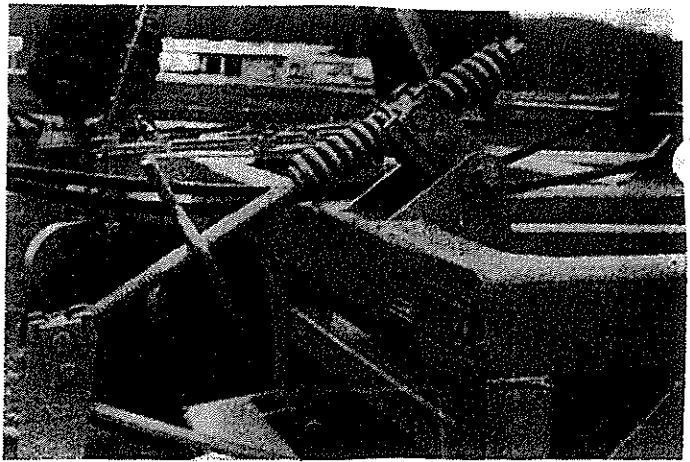

The type of work to be done by the harrow will determine the type of adjustments to be made. Observe the harrow while it is working and check to see if the dead furrow is being filled and the ground left level. If not, an adjustment will have to be made.

If the blade of the rear gang is being "starved" for soil, move the gang slightly to the left or decrease the rear gang cutting angle.

Changing the angle between the gangs will affect the way in which the soil will flow. Some factors are: moisture content of the soil, type of soil, speed of the tractor, depth of penetration, and working angle between the gangs. If any one of the conditions change, there will be a change in the resulting disking job.

To check the quality of disking being done, make one complete round and pass the points where the observation was made.

## DISK GANG ANGLE

The gangs may be set at cutting angles from 15 degrees to 25 degrees depending on soil conditions and job to be done. When conditions are near normal, a setting somewhere between the two extremes is advisable for best operation. The front gang angle can be increased by moving the gang forward. Moving the gang rearward will decrease the gang angle. Moving the rear gang forward will decrease the rear gang angle. Moving the rear gang to the rear will increase the rear gang cutting angle. Be sure to reposition gang frame clamps when making an angle change.

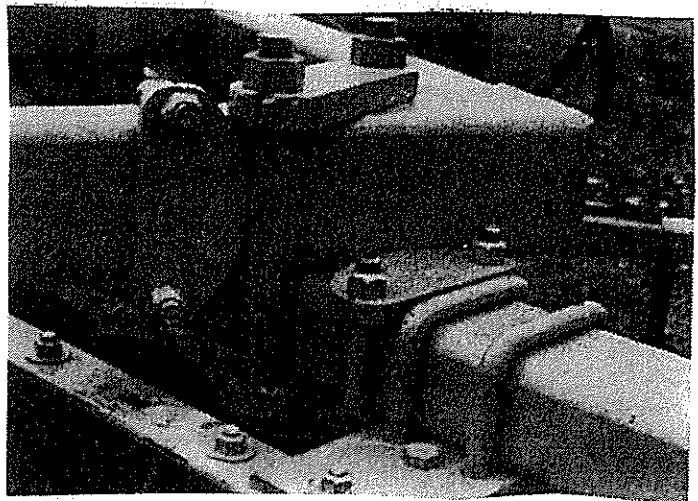

## OFFSETTING THE HARROW

The harrow drawbar may be adjusted so the left tractor wheel can be run in the furrow if that is desirable. Or the left hand tractor wheel may be operated to the right of this furrow, on uncut ground, by making a compensating adjustment on the harrow drawbar. The fields may be laid out so right turns are made by lifting the harrow out of the ground before making the turn.

When the harrow is adjusted so it disks in an extreme left offset position, the front gang will assume a much greater angle (with respect to forward travel) than the rear gang. The rear gang will have a relatively small angle with respect to forward travel.

The small angle of the rear gang makes it more difficult to fill the dead furrow, but the condition can be corrected by using a rear gang adjustment. Usually, the rear gang will have to be shifted to the left.

In general when making a left offset, attempt to keep the amount of offset as small as possible.

The following points are important to remember when offsetting the harrow:

- (1) Offsetting to the left increases the angle of the front gang and decreases the angle of the rear gang.
- (2) Offsetting to the right decreases the angle of the front gang and increases the angle of the rear gang.

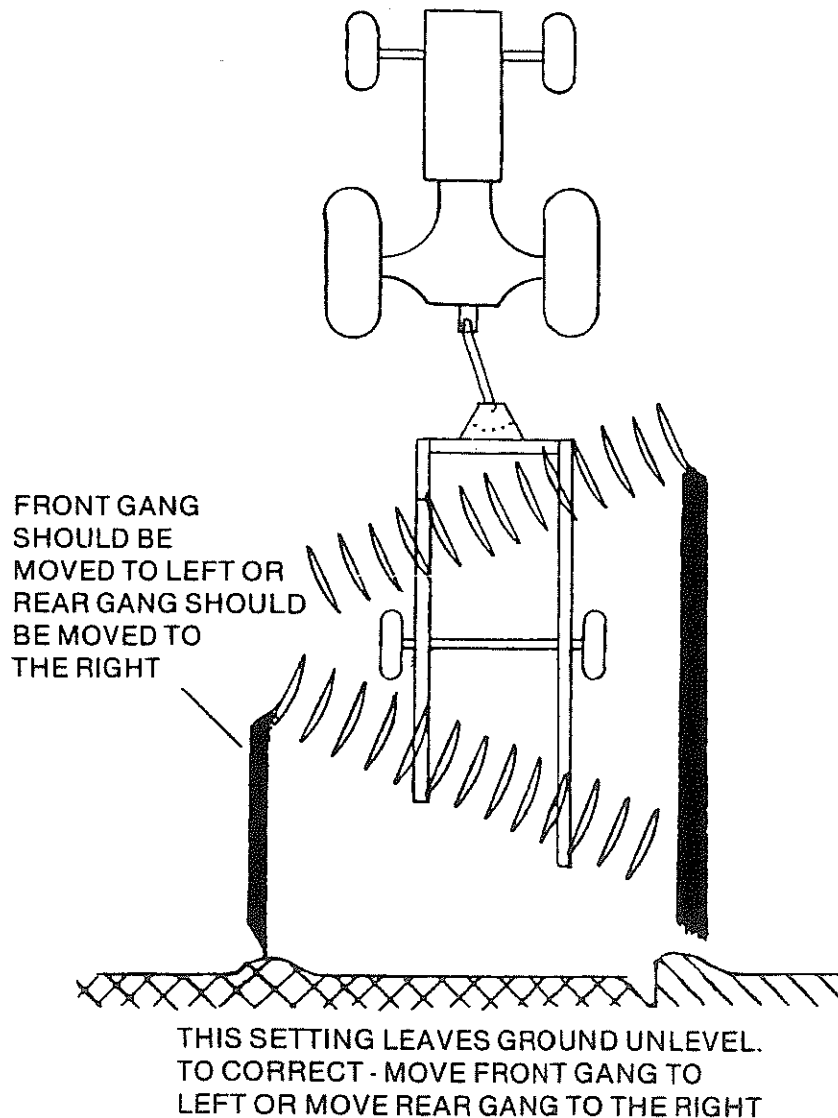

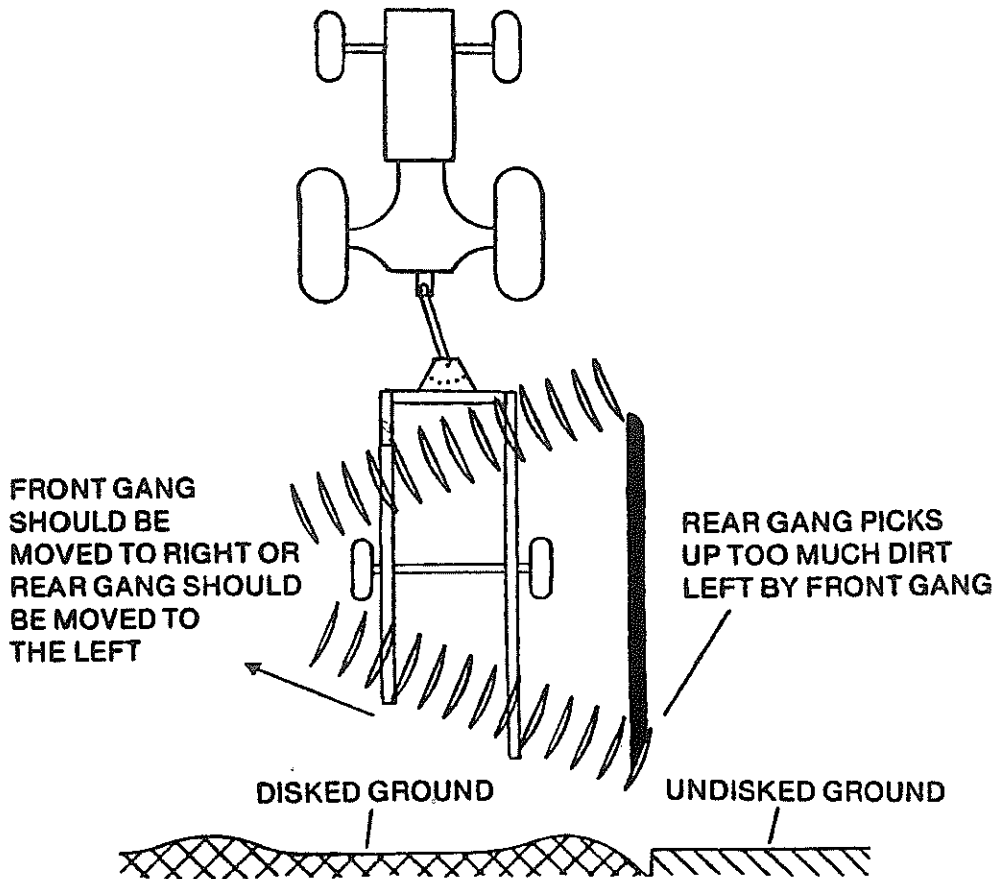

THIS SETTING LEAVES GROUND UNLEVEL.  
 TO CORRECT - MOVE FRONT GANG TO RIGHT OR  
 MOVE REAR GANG TO THE LEFT  
 INCREASE THE ANGLE BETWEEN THE GANGS

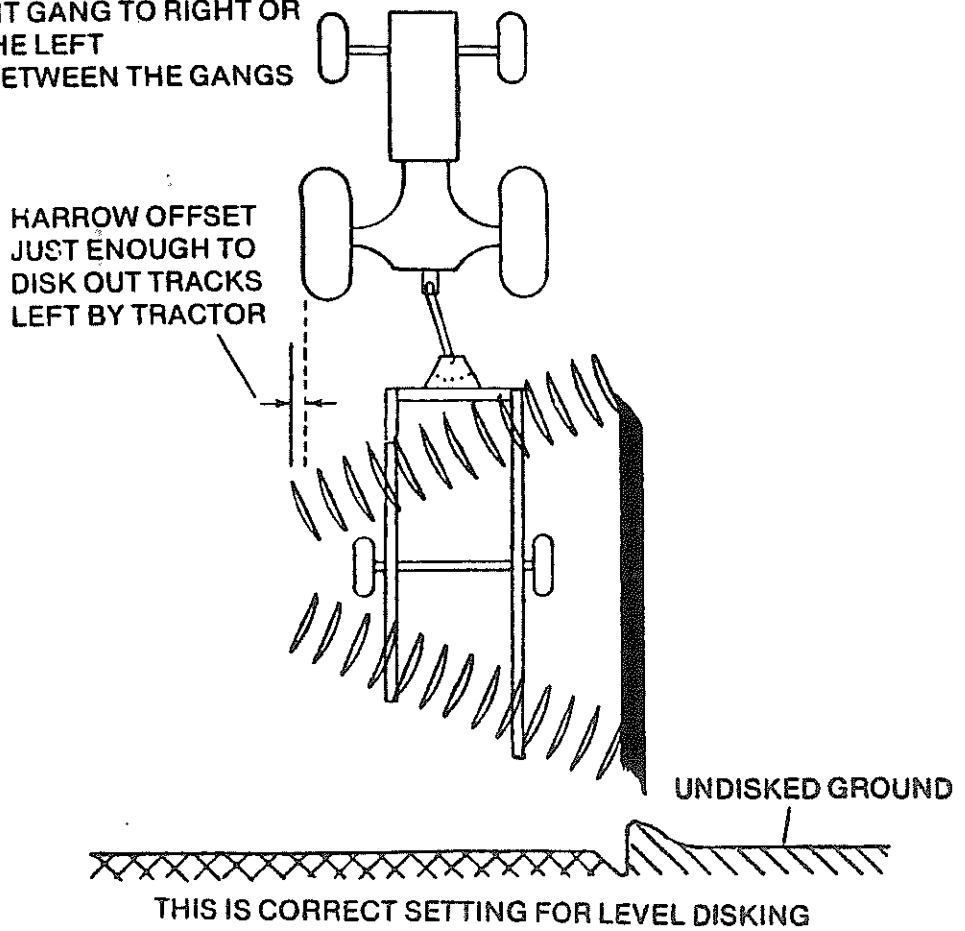



## HYDRAULIC CYLINDER

Attach the rod end of the cylinder to the rockshaft lift arm and the butt end of the cylinder to the main frame. A heavy duty ASAE 4 x 8 hydraulic cylinder is recommended for raising and lowering the disk harrow. On larger harrows weighing over 6500 pounds, a heavy duty ASAE 4 x 16 hydraulic cylinder is recommended. A separate set of holes is located on the rockshaft lift arm and the 86" frame for installing this 4 x 16 cylinder.

## STORAGE

Proper storage will add life to the life of your disk harrow, and assure its being in good condition for the next season. The following procedure is recommended:

- Clean off all foreign matter and lubricate the harrow.
- Repaint the harrow where the original paint has worn off.
- Coat the disk blades with a rust preventative.
- Tighten all loose bolts and replace any damaged or missing parts.
- All hydraulic cylinder rods should be fully retracted or coated with rust preventative to prevent rusting in storage.

## WARNING REFLECTORS

AMCO harrows are equipped with reflective tape on the front and rear of your harrow. Regularly wipe these reflectors clean. Replacement reflectors can be purchased from your authorized AMCO dealer.

## SMV EMBLEMS

The SMV (Slow Moving Vehicle) Emblem is a recommended attachment that should be added to your harrow. Check your state and local laws regarding placement of the SMV Emblem. The SMV Emblem and warning reflectors can be purchased from your authorized AMCO dealer.

## WARNING LAMP

A warning lamp to be mounted on the extreme left hand rear of the harrow is available at your local AMCO dealer.

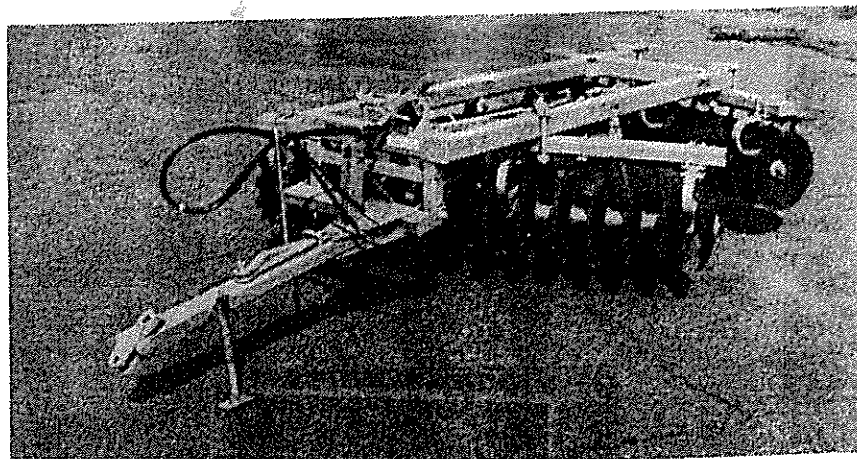

**CAUTION:** *When trailing the harrow over public roads, the SMV Emblem must be used, for protection of tractor and motor vehicle operators.*



**CAUTION:** *When transporting farm implements on public roads after dusk it is the responsibility of the operator to provide lighting and reflectors on the rear of the implement in accordance with your state law.*

# *maintenance*

1. Keep all bolts tight.
  - A. Check before placing in service.
  - B. Visually inspect all bolts daily.
  - C. Check after first 50 hours or one week's operation.
  - D. Check each season.
2. Do not run with loose disk blades. Keep gang bolts tight! Tighten gang bolts to 900--1000 ft.-lbs. of torque.
3. Grease gang bearings and rockshaft retainer pins every week or 50 hours, at the start of each season, and at the end of each season. Apply with low pressure, low volume hand grease gun. Use a good No. 2 gun grease (Lithium Base). Rotate gangs while greasing for best results.



**CAUTION:** *Use care to prevent damage to seals.*

4. Disk Blade, Bearing, and Spool Replacement.
  - A. Remove the nuts that hold the gang bearing housing trunnion clamps.
  - B. Remove clamps.
  - C. Raise the harrow and roll the gang away from the frame.
  - D. Remove the gang nut lock plate.
  - E. Remove the gang hex nut from the end of the shaft.
  - F. Slide off the bearing spools, spacers, and blades.
  - G. Avoid thread damage.
  - H. Tear the entire gang down and clean all parts. Check disk axle for straightness. Bowed, bent or worn axles must be replaced.
  - I. Check spacer spools for damage caused by running disk with loose gangs or hitting underground obstructions. Replace spool if it is damaged.
  - J. Carefully check all end bells. The large end must contact the disk blade around the entire circumference of the end bell. The small end must be smooth and perpendicular to the axle. The end bells must be replaced if they are cracked or worn on the surface adjacent to the bearing.
  - K. Check all the bearings on the gang. Running a harrow for one hour or more after bearing failure will seriously damage other bearings on the gang. This damaged bearing will then fail within a few hours after the failed bearing has been replaced. Continued operation with this failed bearing will damage the new bearing; thus, it will fail after a few hours of use. In most cases it will be best to replace all bearings on a gang when it is torn down for repairs. A triple lip sealed bearing should always be used for bearing replacement. Also, a regreasable type bearing should always be used.

- L. To replace the bearing, the snap ring must be removed. The old bearing should be pressed out of the housing. Clean and wash out old grease and carefully check the housing. Replace the housing if it is damaged. Press the new bearing straight into the housing. Always press against the outer race of the bearing. NEVER press against the seal or inner race of the bearing. Check location of the grease hole in the outer race of the bearing. This hole must align with the grease groove in the bearing housing. Rotate the bearing in the housing after it is pressed in to be sure it turns freely. Install the snap ring in the housing.
- M. After cleaning, checking and replacing all damaged parts, the gang should be assembled. Be sure the grease fittings in the bearing housing face to the rear. Be sure the snap ring in the bearing housing is turned toward the convex (back) side of the disk blade. The 1-1/2" square gang bolt nut should be torqued to 900-1000 ft.-lbs. The axle nut should be locked in place with the lock strap.
- N. After the gang is assembled it should be attached to the harrow. The bearing risers should be carefully spaced to match the bearing housings. Poorly spaced bearing risers will overload the bearings and cause premature failure. The gang should be rotated 4 or 5 complete revolutions to be sure that all parts are aligned and the gang turns freely.
- O. The bearings should be greased each week or every 50 hours of use with a good grade of clean, No. 2, lithium soap base grease. Use of dirty grease or a grease with metal additives will reduce bearing life. Protect-O-Shield bearings should be greased until grease "pops" out around the bearings. The bearing will thus be purged of any dirt or foreign matter. The Protect-O-Shield prevents any possibility of blown seals.

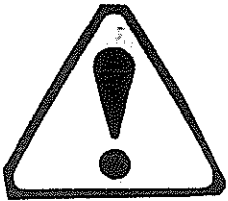

**CAUTION:** *When working on disk harrows, care should be exercised in handling or tightening bolts near disk blades to avoid injury. All hydraulically or mechanically elevated components must be blocked or lowered to prevent accidents when servicing the harrow.*

It is essential that gang bolts be kept tight to prevent axle bending, blade breakage, spacer spool breakage and damage to other gang parts. Gang parts tend to wear on a bevel when the harrow is operated with a loose gang bolt. This reduces the area of contact between mating gang parts. Therefore, it is often difficult to keep a gang bolt tight if it has been operated in a loose condition. After such a gang bolt has been properly torqued it should be retorqued after about 30 minutes of operation, again after 4 or 5 hours of operation and again after 8 to 10 hours of use. This will assure that proper gang bolt tension is maintained while the mating components are reseating. If the gang bolt will not stay tight, the gang should be completely disassembled and all parts carefully inspected. All damaged parts should be replaced before reassembling the gang.

## 5. WHEEL BEARINGS

The wheel hubs are equipped with tapered roller bearings. These hubs are packed with grease and adjusted at the factory. They should be repacked and the spindle nut properly adjusted each season or every 300 hours of operation. Use good grade No. 2 grease (Lithium Base).

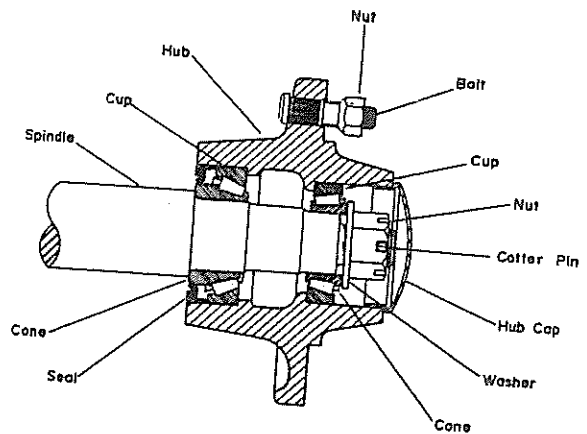

Wheel Bearings should be repacked with grease and adjusted annually. Under extreme conditions, they should be serviced more frequently. Check occasionally for excessive end play. Adjust as required to eliminate excessive end play.

To disassemble the hub, remove the wheel, then remove the dust cap by prying around it. Remove the cotter pin, slotted nut and flat washer. Carefully remove the hub and bearings from the spindle. Thoroughly clean and carefully inspect all parts for wear. All parts that appear to be worn or damaged must be replaced.

Use the following procedure when repairing or servicing wheel hubs:

- A. Clean all parts that are to be re-used.
- B. Carefully inspect the metal case on the grease seal. Discard the seal if the case is bent or damaged. Check seal lips for cuts, tears or excessive wear. Seal must fit snugly on extended inner race of bearing.
- C. Carefully inspect both sets of bearing cones. Bearing bore and rollers must be smooth and free of nicks and scratches. Replace cones if damaged.
- D. Inspect hub to make sure that the bolt holes have a full thread. Bearing cones must be smooth and free of surface blemishes. Cups must be removed from the hub and replaced if damaged. Cups should be fully pressed into the hub and rest squarely against the shoulder inside the hub. Hub cap and grease seal should fit snugly inside the hub. Severely damaged hubs should be replaced.
- E. Threads on spindle must be in good condition. Bearing cone seats must be smooth and free of blemishes. Bearing cones must fit squarely on the spindle.
- F. Flat washer, slotted nut, cotter pin and hub cap must be in good condition. Replace if worn or damaged.
- G. To reassemble the hub, repack each bearing cone with grease and fill the hub cavity 1/3 full of grease. Place inner bearing assembly in hub, press grease seal into hub and carefully re-install the hub on the spindle. Install the outer bearing assembly into the hub and replace the flat washer and slotted nut. Tighten the slotted nut to seat the bearings, until the hub binds when rotated.
- H. Back the slotted nut off to the nearest slot. Rotate the hub five or six revolutions in each direction to seat all parts. Re-tighten the slotted nut while rotating the hub. When hub binds, back the nut off to the nearest slot and install the cotter pin. Install the hub cap and re-mount the wheel on the hub.

6. **SCRAPER REPAIR:** Bent scraper bars or shanks should be replaced or straightened if possible. The blades can be replaced when they wear to the extent they are not performing properly. Keep the blades adjusted from 1/16" to 1/8" from the disk blades. The scrapers can be adjusted by loosening the mount bolt and sliding the scraper to the proper position then tightening the mount bolt. Additional adjustment can be obtained by loosening the scraper bar mount bolts and shifting the entire scraper bar. Do not allow the scraper blades to run on the spools as immediate damage to spool will occur.

7. **ROCKSHAFT PIVOT PIN REPAIR:** The rockshafts are equipped with replaceable, regreasable, bronze bushings. If properly lubricated they should last for several seasons. The bushings should be checked each disking season as damaged parts will damage other parts.

8. **HYDRAULIC CYLINDER REPAIR:**

- A. Remove hoses and fittings from cylinder.
- B. Remove cylinder from harrow and clean outside of cylinder.
- C. Dis-assemble cylinder by removing the rods and nut from end of cylinder rod. Slip piston and gland off cylinder rod.
- D. Carefully clean and inspect all parts for wear or damage. Small nicks, scratches or blemishes on rod and inside of barrel should be smoothed with fine steel wool or emory cloth. Replace parts that cannot be repaired.
- E. Remove all "O" Rings from piston and gland. Replace all seals with new parts.
- F. Assemble cylinder using care to prevent damage to "O" Rings and Seals.
- G. Replace cylinder on harrow and attach hoses. Check cylinder for leaks.

# *operating tips*

## OPERATING TIPS FOR LONG LIFE AND SATISFACTORY PERFORMANCE

1. Match the harrow with the proper size tractor. Too much horsepower and speed will result in excessive maintenance cost.
2. Lubricate with clean grease at the recommended interval.
3. Use good quality tires, hoses, and hydraulic cylinders.
4. Use the tongue adjusting rod, proper cutting depth, and travel speed to get level disking and smooth fields.
5. Wash corrosive materials such as fertilizer and herbicides from the disk when it is not in use.
6. Insist on genuine AMCO replacement parts. Items such as bearings and blades look alike but are not as reliable as original equipment.
7. Never allow unsafe conditions or operating practices. Your safety is of prime importance.
8. Raise the disk harrow on its transport wheels when turning. Failure to do so will result in broken blades, bent axles, and excessive strain on the tongue and main frame.
9. Reduce operating speed in areas containing stumps or rocks to reduce blade breakage.



**CAUTION:** *Hydraulic systems are highly pressurized. Escaping hydraulic oil, even an invisible pinhole leak, can penetrate body tissues causing serious injury. Use a piece of wood or cardboard when looking for leaks - never use the hands or other parts of the body.*

*Relieve hydraulic pressure before disconnecting circuits. When reassembling, make absolutely certain that all connections are tight.*

*If injured by hydraulic oil escaping under pressure, see a doctor immediately. Serious infection or reaction may occur if medical attention is not given at once.*

# 50" MAIN FRAME

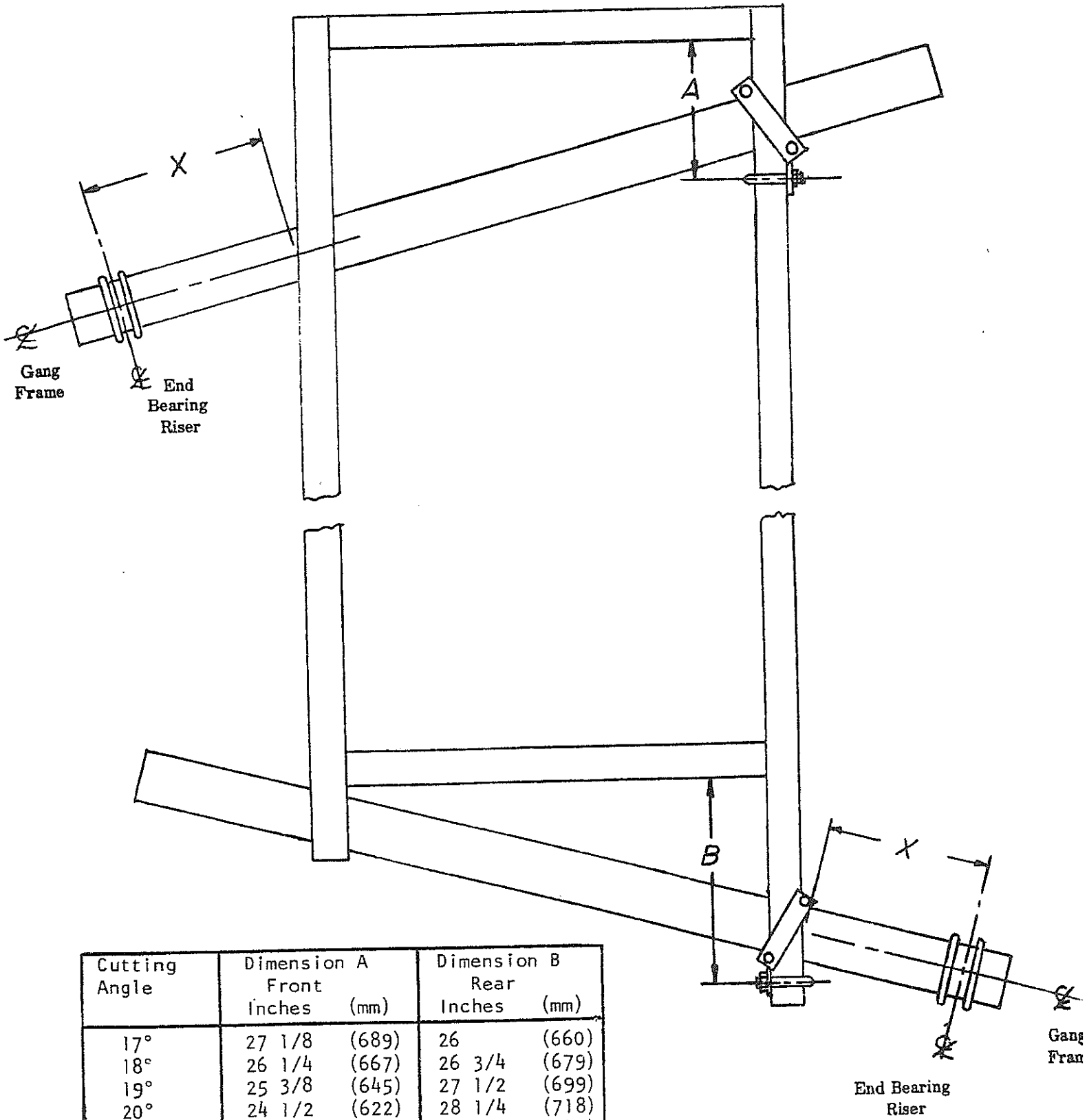

Cutting Angle	Dimension A Front		Dimension B Rear	
	Inches	(mm)	Inches	(mm)
17°	27 1/8	(689)	26	(660)
18°	26 1/4	(667)	26 3/4	(679)
19°	25 3/8	(645)	27 1/2	(699)
20°	24 1/2	(622)	28 1/4	(718)
21°	23 1/2	(597)	29 1/4	(743)
22°	22 5/8	(575)	30	(762)
23°	21 3/4	(552)	31	(787)
24°	20 3/4	(527)	32	(813)
25°	19 7/8	(505)	33	(838)

Note: Cutting angle dimensions are approximately only

# 86" MAIN FRAME

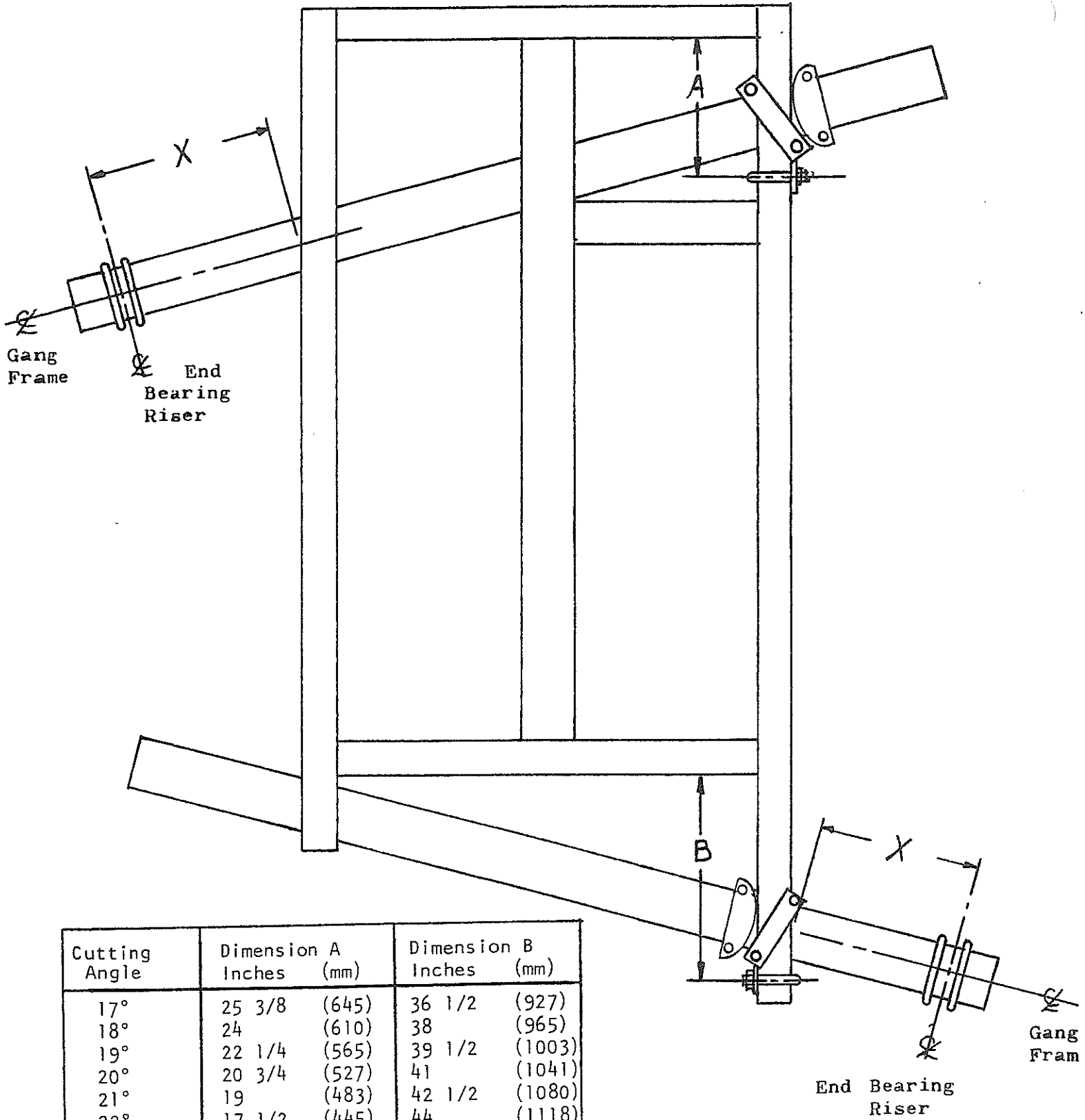

Cutting Angle	Dimension A		Dimension B	
	Inches	(mm)	Inches	(mm)
17°	25 3/8	(645)	36 1/2	(927)
18°	24	(610)	38	(965)
19°	22 1/4	(565)	39 1/2	(1003)
20°	20 3/4	(527)	41	(1041)
21°	19	(483)	42 1/2	(1080)
22°	17 1/2	(445)	44	(1118)
23°	15 3/4	(400)	45 3/4	(1162)
24°	14	(356)	47	(1194)
25°	12 5/8	(314)	48 3/4	(1238)

Note: Cutting angle dimensions are approximate only.



## GANG PLACEMENT CHART

Dimension "X" is measured from the outside of the Main Frame along the Center Line of the Gang Frame to the Center of the End Bearing Riser.

MODEL	DIMENSION [X]		MODEL	DIMENSION [X]	
	INCHES	[mm]		INCHES	[mm]
F42-22 Blade	23 7/8	(606)	J43-20 Blade	24 11/16	(627)
F42-24 Blade	28 1/8	(724)	J43-24 Blade	35 3/8	(899)
F42-28 Blade	37 3/4	(959)	J43-28 Blade	46 1/16	(1170)
F42-32 Blade	47	(1193)	J43B-28 Blade	27 7/8	(708)
F42B-32 Blade	28 13/16	(732)	J43-32 Blade	37 1/4	(946)
F42-36 Blade	36 3/4	(933)	J43-36 Blade	47 15/16	(1218)
F42-40 Blade	46	(1168)	J43-40 Blade	58 5/8	(1489)
F42-44 Blade	55 1/4	(1403)	J43-44 Blade	69 5/16	(1761)
F42-48 Blade	64 1/2	(1638)			
F42-54 Blade	78 3/8	(1990)			
J42-20 Blade	24 11/16	(627)	J44-20 Blade	24 11/16	(627)
J42-24 Blade	35 3/8	(899)	J44-24 Blade	35 3/8	(899)
J42-28 Blade	46 1/16	(1170)	J44-28 Blade	26 9/16	(1170)
J42B-28 Blade	27 7/8	(708)	J44-32 Blade	37 1/4	(946)
J42-32 Blade	37 1/4	(946)	J44-36 Blade	47 15/16	(1218)
J42-36 Blade	47 15/16	(1218)	J44-40 Blade	58 5/8	(1489)
J42-40 Blade	58 5/8	(1489)	J44-44 Blade	69 5/16	(1761)
J42-44 Blade	69 5/16	(1761)			
J42-48 Blade	80				

## MOST OFTEN ENCOUNTERED DISK BLADE FAILURES

Most disk blade failures can be prevented by selecting the correct blade size and thickness for individual conditions when buying a disk. Reduction of speed in areas containing rocks and stumps will greatly lengthen the blade life. Keeping gang bolts properly torqued and raising the harrow while turning will also reduce disk blade breakage.

FIGURE 1 — Laminated Disc—defective steel. Eligible for warranty consideration.

SURFACE VIEW

EDGE VIEW

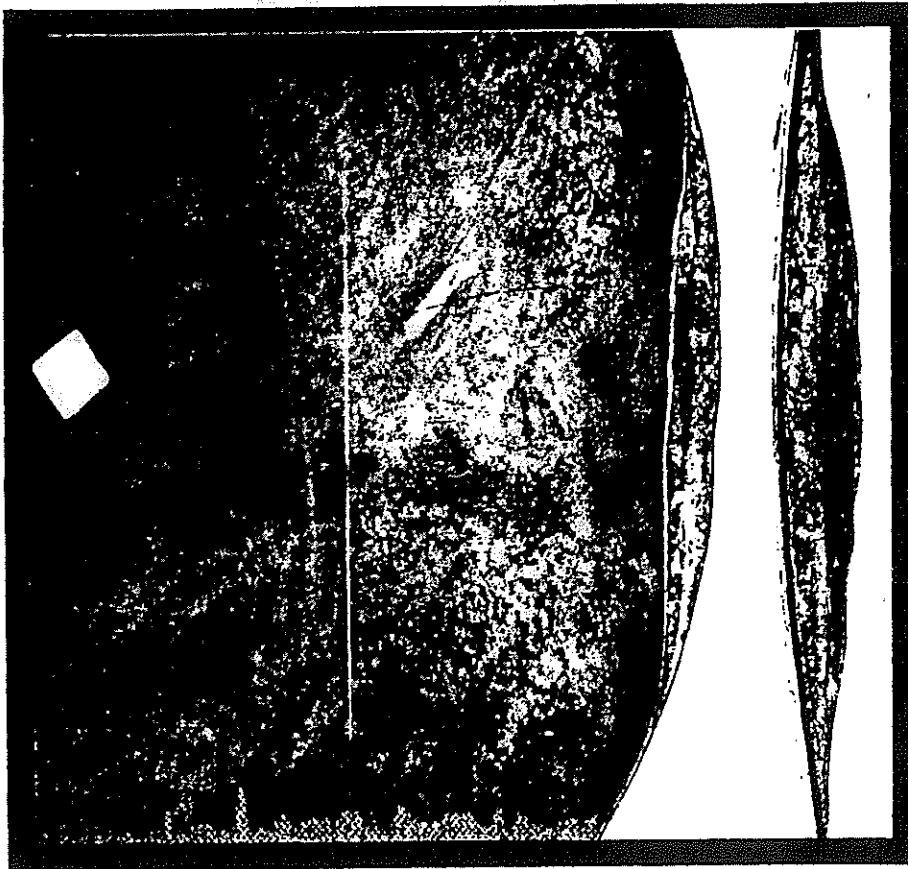

FIGURE 2 — Straight directional break caused by defective steel. Eligible for warranty consideration.



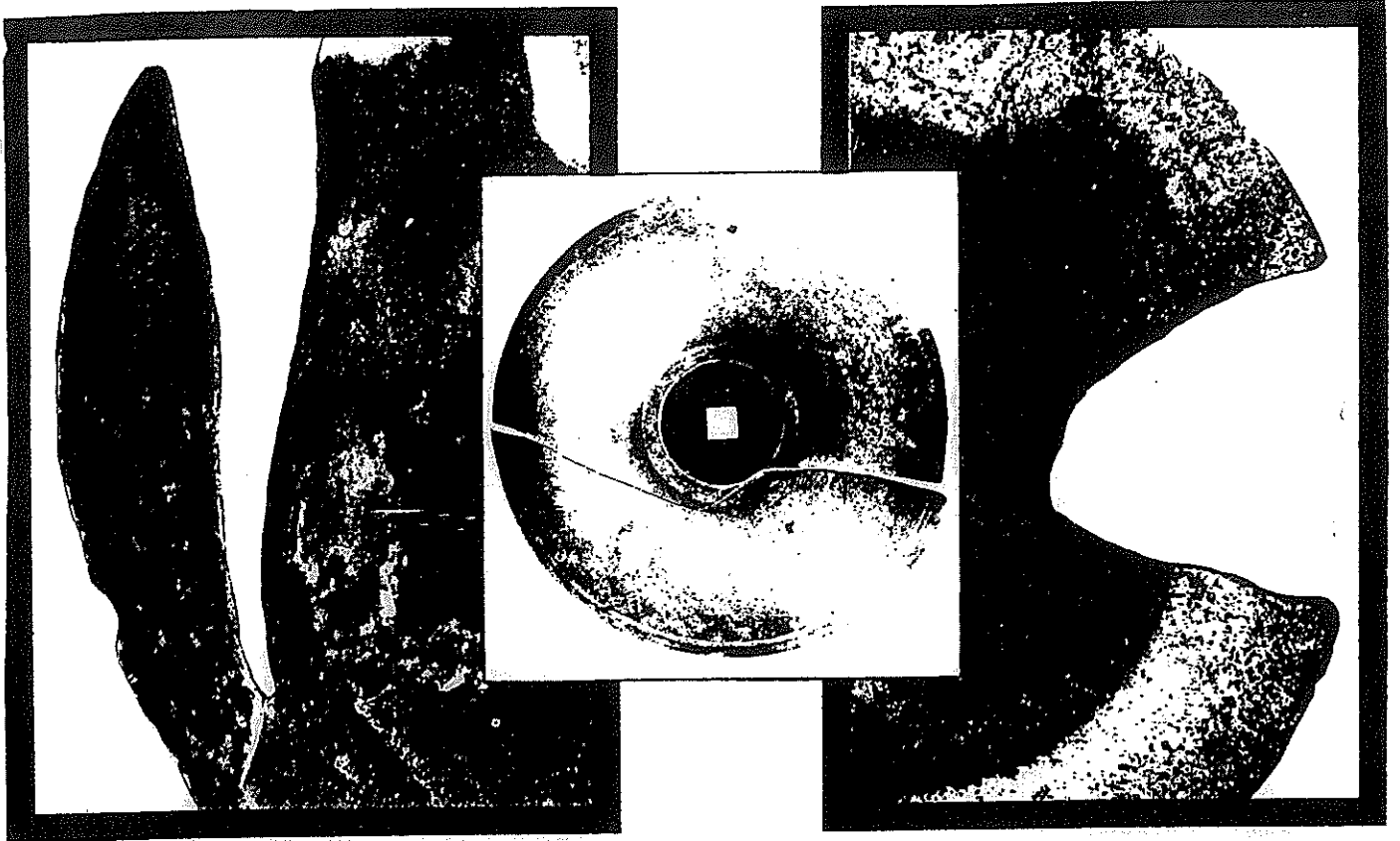

FIGURE 3, 4, 5 — Irregular breaks caused by contact against rocks or stumps. Not covered by warranty.



FIGURE 6 — Chipped or dented edges resulting from use in areas containing rocks or stumps. Not covered by warranty.



FIGURE 7 — Center broken out—Experience has shown that this is usually caused by loose bolts, excessive flexing, or by contact with rocks and stumps. Not covered by warranty.

---

11  
12