

Vertical Electrophoresis Units

**Cat. No. BT202, BT203, BT204, BT205,
BT206, BT207 & BT208**

SAFETY PRECAUTION	3
MAINTENANCE.....	3
CLEANING UNITS.....	3
RNASE DECONTAMINATION	3
SETTING UP THE VERTICAL GEL TANKS:-.....	4
INSTRUCTIONS FOR FITTING ELECTRODE CABLES (IF REQUIRED)	4
VERTICAL GEL CASTING.....	4
USING THE GEL CASTING FRAME: (FOR BT202 & BT203)	4
USING THE GEL CASTING BASE: (FORBT204, BT207 & BT208)	5
USING THE GEL MAKING MODULAR DEVICE: (FOR BT205 &BT206)	6
GEL POURING.....	6
RUNNING THE GEL	6
WARRANTY	7
TECHNICAL SUPPORT	7

SAFETY PRECAUTION



WHEN USED CORRECTLY, THESE UNITS POSE NO HEALTH RISK. HOWEVER, THESE UNITS CAN DELIVER DANGEROUS LEVELS OF ELECTRICITY AND ARE TO

BE OPERATED ONLY BY QUALIFIED PERSONNEL FOLLOWING THE GUIDELINES LAID OUT IN THIS INSTRUCTION MANUAL.

ANYONE INTENDING TO USE THIS EQUIPMENT SHOULD READ THE COMPLETE MANUAL THOROUGHLY.

THE UNIT MUST NEVER BE USED WITHOUT THE SAFETY LID CORRECTLY IN POSITION.

THE UNIT SHOULD NOT BE USED IF THERE IS ANY SIGN OF DAMAGE TO THE EXTERNAL TANK OR LID.

MAINTENANCE

Cleaning Units

Units are best cleaned using warm water and a mild detergent. Water at temperatures above 60°C can cause damage to the unit and components.

The tank should be thoroughly rinsed with warm water or distilled water to prevent buildup of salts, but care should be taken not to damage the enclosed electrode and vigorous cleaning is not necessary or advised.

Air drying is preferably before use.

The units should only be cleaned with the following:

Warm water with a mild concentration of soap or other mild detergent. Compatible detergents include dishwashing liquid, Hexane and Aliphatic hydrocarbons.

The units should not be left in detergents for more than 30 minutes.

The unit should never come into contact with the following cleaning agents, these will cause irreversible and accumulative damage.

Acetone, Phenol, Chloroform, Carbon tetrachloride, Methanol, Ethanol, Isopropyl alcohol.

Rnase Decontamination

Clean the units with a mild detergent as described above. Wash with 3% hydrogen peroxide (H₂O₂) for 10 minutes. Rinsed with 0.1% DEPC (diethyl pyrocarbonate) treated distilled water.

Caution: DEPC is a suspected carcinogen. Always take the necessary precautions when using.

RNaseOUT™ (G-Biosciences) can also be used. Please consult the instructions for use with acrylic gel tanks.

SETTING UP THE VERTICAL GEL TANKS

Instructions for fitting Electrode Cables (If required)

1. Note the position of the lid on the unit. This shows the correct polarity and the correct orientation of the cables, black is negative and red positive.
2. Remove the lid from the unit, Note if the lid is not removed, fitting the cables may result in un-tightening of the gold plug and damage to the electrode.
3. Screw the cables into the tapped holes as fully as possible to that there is no gap between the lid and the leading edge of the cable fitting.
4. Refit the lid.

VERTICAL GEL CASTING

Using the Gel Casting Frame: (For BT202 & BT203)

1. Clean glass plates, flush with distilled water, let them dry in the air.
2. Overlap a spacer plate with a notched one, put the two glasses into the core, keep their bottoms contacting the table and insert a cuneal plate closely outside the two plates.
3. Use the same method to complete the other side.
NOTE: *The spacer plate should be put outside and the notched plate on the inside. The operation must be done on a level surface. The bottom ends of glass plates must be perfectly aligned.*
4. Put the core with installed plates in the Gel casting frame, hang over the hooks on both sides of the core, press down the wrenches to make the bottom of the glass plates be sealed by the rubber. See diagram below:

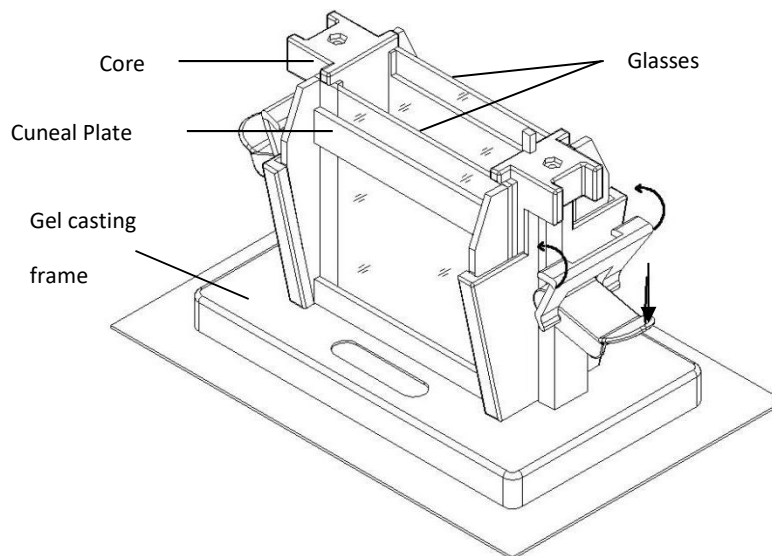

Using the Gel casting base: (For BT204, BT207 & BT208)

1. Clean glass plates, flush with distilled water, let them dry in the air.
2. Overlap a spacer plate with a notched one, put the two glasses into the core, keep their bottoms contacting the table, and rotate the cam wrench outwards to press the glasses.
3. Use the same method to complete the other side.

NOTE: The spacer plate should be put outside and the notched on the inside. The operation must be done on a level surface. The bottom ends of glass plates must be perfectly aligned.

4. See diagram below:

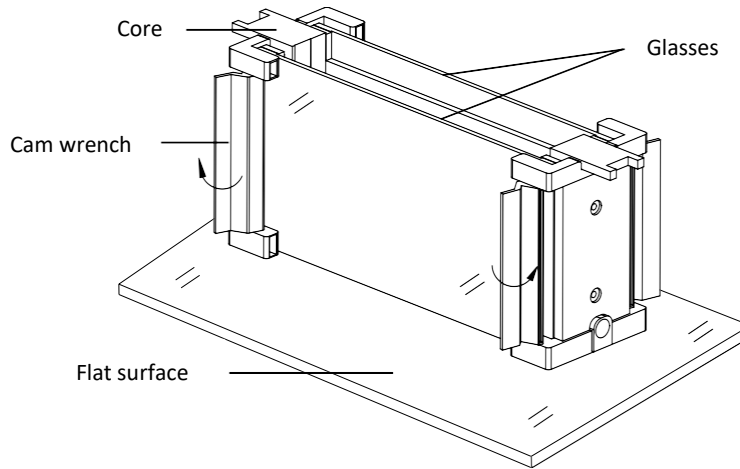

5. Pull out the handle of the gel casting base, rotate the handle downwards and put the core in the gel casting base. See diagram below

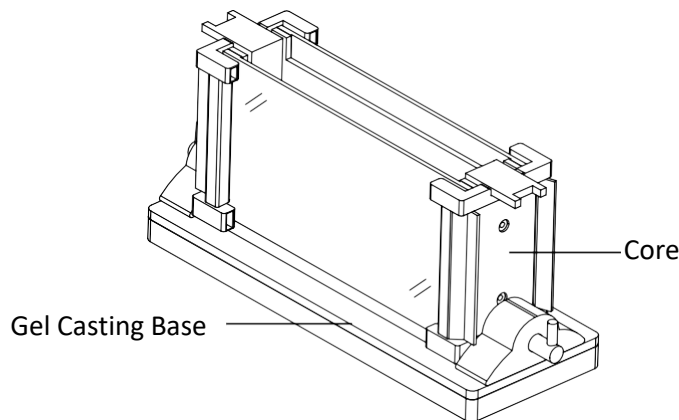

6. Put the handle into the hole and rotate upwards. See diagram below:

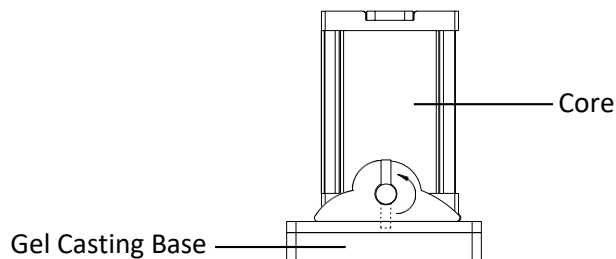

Using the Gel making modular device: (For BT205 & BT206)

1. Cleaning glass plates, flush with distilled water, let them dry in the air.
2. Drop in the agarose solution into the sealing groove by the dropper. See diagram below:

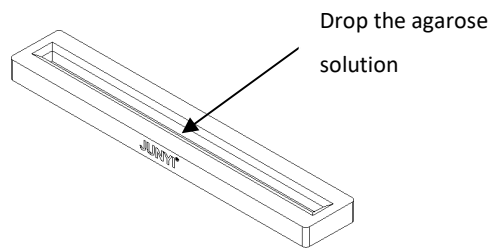

3. Overlap a spacer plate with the notched one, put a clip to each side, and put them into the Gel making device modular. See diagram below:

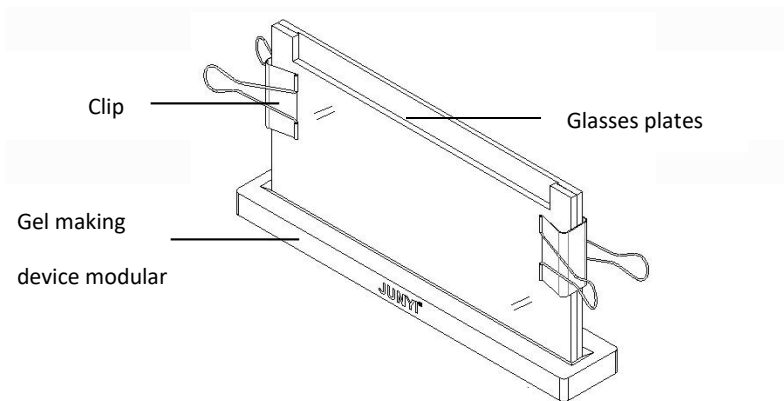

GEL POURING

1. Pour the gel into the gel blocks carefully so as not to generate bubbles.
2. Carefully insert the comb, make sure there is no air bubbles under the ends of the comb teeth.
3. Leave the gel by itself and wait for it to set.
4. Pull the comb(s) out carefully.
5. Pull the comb(s) out carefully and move the core with the gel to the main tank

RUNNING THE GEL

1. Put the core into the bottom tank.
2. Fill 1x buffer into the upper tank, as well as the bottom tank.
3. Load the samples into the wells with pipettes and take care not to damage the wells or induce bubbles.
4. Carefully cover the tank with lid and connect it with a power supply.
5. Typically gels run under 150V- 200V. Be noted that, generally higher voltage enables faster electrophoresis but poorer quality of sample resolution.
6. Run electrophoresis.

WARRANTY

BT Lab Systems warrants apparatus of its manufacture against defects in materials and workmanship, under normal service, for ***one year from the shipping date to purchaser***. This warranty excludes damages resulting from shipping, misuse, carelessness, or neglect. BT Lab Systems' liability under the warranty is limited to the receipt of reasonable proof by the customer that the defect is embraced within the terms of the warranty. All claims made under this warranty must be presented to BT Lab Systems within one year following the date of delivery of the product to the customer.

TECHNICAL SUPPORT

BT Lab Systems offers technical support for all of its products. If you have any questions about the product's use or, operation, please contact BT Lab Systems at the following info.

E-Mail: info@BTLabSystems.com