

We know you will be amazed with the ease of installing elfa. If at any time during installation you have questions, call the store listed on your receipt or 1-800-733-3532. You may also visit containerstore.com/installation to view video instructions.

TIPS for getting started

- Remove all contents from your space and donate or sell all items no longer needed.
- Place clothes that you are keeping on a garment rack outside the closet during installation.
- Take out old shelving and closet rods. Patch and repaint walls.
- Tape each page of your custom space design to the corresponding wall.
- Refer to your custom space design for placement of your elfa. Lay out all the products by type, size and wall.
- Tools needed: pencil, scissors, level, power drill, drill bits, #2 Phillips head bit for power drill, #2 Phillips head screwdriver, hammer, tape measure, ladder or step stool.
- Be careful not to drill into any electrical wires, ductwork, plumbing or other damageable components. If you have any questions on the locations of these wires or lines, **please contact a professional electrician or plumber before drilling.**

elfa Easy Installation & Assembly Quick Reference

■ Top Track, Hardware and Hanging Standards	pg. 2-4
■ Hanging Drawers, Gliding Accessory Racks, décor Shelves and Fascia	pg. 5-6
■ Ventilated Shelves and Closet Rods	pg. 7
■ Solid Shelving	pg. 8-10
■ Wall-Mounted Standards	pg. 11
■ Drawer Units	pg. 12

Top Track, Hardware and Hanging Standards

TIP

- Top Tracks have a top and a bottom. The **TOP** is designated by a label and has **two notches** to allow Hanging Standards to be inserted properly.

Step 1 Level the Top Track

- Place the Top Track at desired height (refer to your custom space plan). Place the level at the bottom of the Top Track to ensure it is straight. **(Figure A)**

TIP

- For longer Top Tracks, drill the center hole and secure with one screw. Tighten the screw enough to hold the Top Track against the wall while leveling and marking the rest of the holes.

- While leveling your Top Track, mark all the holes with a pencil.
- Set the Top Track aside, then drill all marked holes with a 1/8" drill bit. **(Figure B)**
- If you hit wood, continue drilling the entire length of the drill bit.
- In most applications, you will not hit wood for every hole. If you find you've hit the hollow part of the wall, mark that hole with a small "X." **(Figure B)**
- The "X" is to remind you, after drilling all holes, to go back and enlarge that hole with the appropriate drill bit size for the hardware needed for your wall construction (see pg. 3).

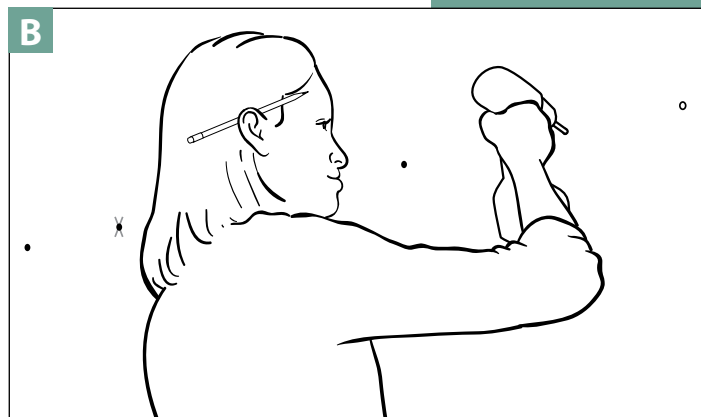
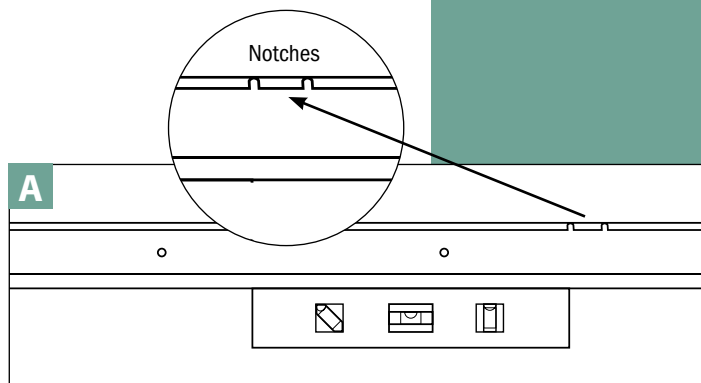

Step 2

Hardware

Based on what you have told your designer, you have been provided with the correct hardware needed to complete the installation based on your wall construction. Below are instructions for installing each type of hardware:

Wood or Wood Studs (Figure C)

Used for mounting the Top Track into drywall over wood studs or directly into wood.

- Drill a hole with a 1/8" drill bit the length of the drill bit.

TIP

- Rake the Wood Screw over a bar of soap before inserting it into the wall. This will make tightening the screw easier.

1/2" thick drywall (most common wall type) (Figure D)

- Enlarge hole with a 3/8" drill bit.
- Remove the screw from the dark blue anchor.
- Tap the anchor into the hole.
- Remove and discard the grey spacer.

5/8"-1" thick walls or plaster (Figure E)

- Enlarge hole with a 3/8" masonry drill bit.
- Remove the screw from the red anchor.
- Tap the anchor into the hole.
- Remove and discard the grey spacer.

Sheet Metal (Figure F)

- Screws for mounting into drywall over sheet metal studs.
- Drill a hole with an 1/8" drill bit the length of the sheet metal screw.

Concrete/Masonry (cinder block or brick) (Figure G)

- Drill a hole with a 5/32" masonry drill bit the length of the concrete screw.

Masonry with Furring* (Figure G)

- Drill a hole with a 5/32" masonry drill bit the length of the concrete screw.

* Furring is a space usually 3/4" between the drywall and masonry surface. Furring strips are 1" x 2" pieces of wood attached to the masonry. The drywall is attached to the furring strips. When possible, the Top Track should be installed over the furring strip.

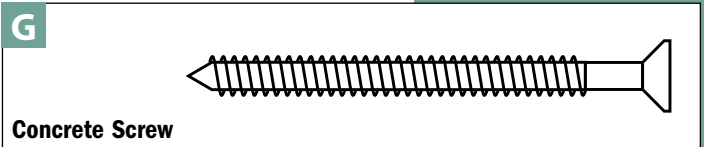
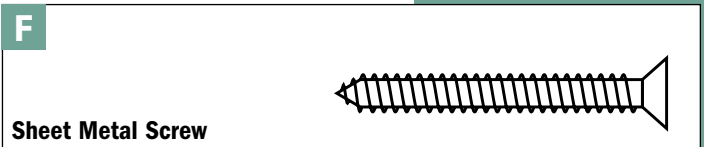
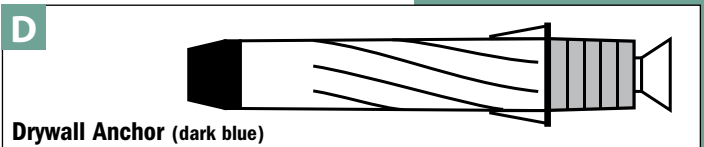
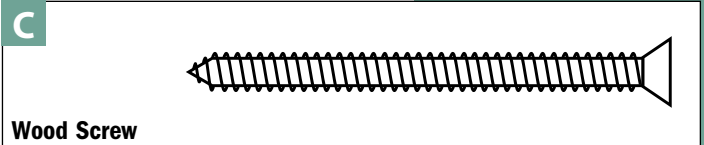

Step 3 Install the Top Track

TIP

- Be careful not to drill into any electrical wires, ductwork, plumbing or other damageable components. If you have any questions on the locations of these wires or lines, **please contact a professional electrician or plumber before drilling.**

- Place the Top Track on the wall and insert and tighten all the screws using a power drill with a #2 driver bit. **(Figure A)**
- To avoid stripping the screw, finish hand tightening with a #2 Phillips head screwdriver.
- **In order for the dark blue or red wall anchors to be secure, it is important to tighten the screw until it stops turning.**
- **When using the Masonry Screw, it is important NOT to overtighten, because this may result in a stripped screw.**

Step 4 Install the Hanging Standards and Shelf Brackets

- Insert the Hanging Standards in the Top Track notches. **(Figure B)**
- Group Hanging Standards together and insert Brackets at the appropriate height based on your space plan. **(Figure C)**
- Slide the Hanging Standards to their approximate position on the Top Track. Refer to your custom space plan for placement of the Hanging Standards.
- Hanging Standards should be a minimum of 1/2" from the ends of the Top Track.

To install Solid Shelving, go to page 8.

Top Track Cover Installation

- **You should install your Top Track Cover after you have completed all the installation steps in this booklet. Please refer to the instructions below once you have placed all of your Shelves and your Drawers and are satisfied with the positioning of your elfa Shelving.**
- Because the Top Track Cover is placed between the Hanging Standards, the Shelves must be in place to ensure the spacing between the Hanging Standards is set.
- Start with long pieces first. Place the bottom of the Top Track Cover into the bottom of the Top Track, then ease the top of the Top Track Cover into the top of the Top Track.
- Measure the area on the Top Track where smaller pieces of the Top Track Cover are needed.
- Measure and mark the Top Track Cover where the cuts need to be. The Cover is easily cut in a straight line with scissors.
- Do not overlap segments of the Top Track Cover.

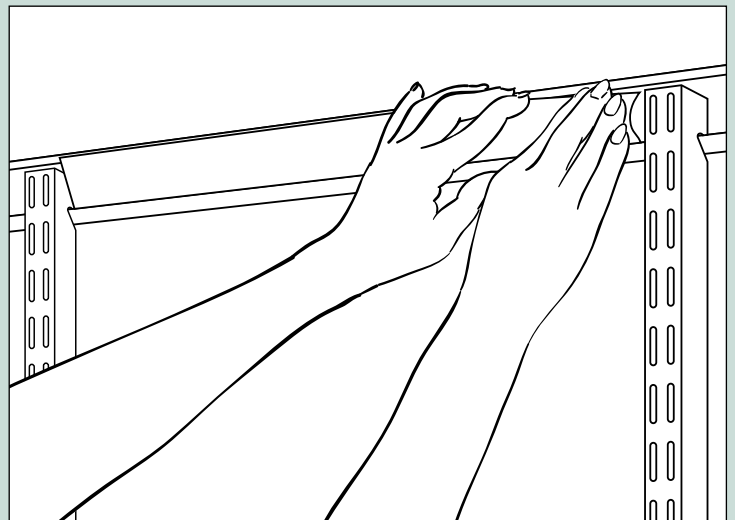
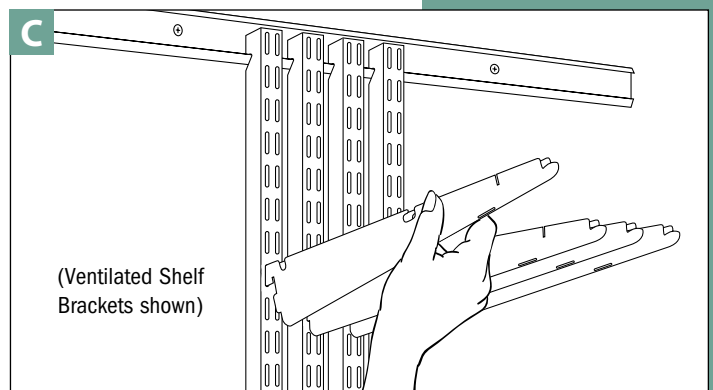
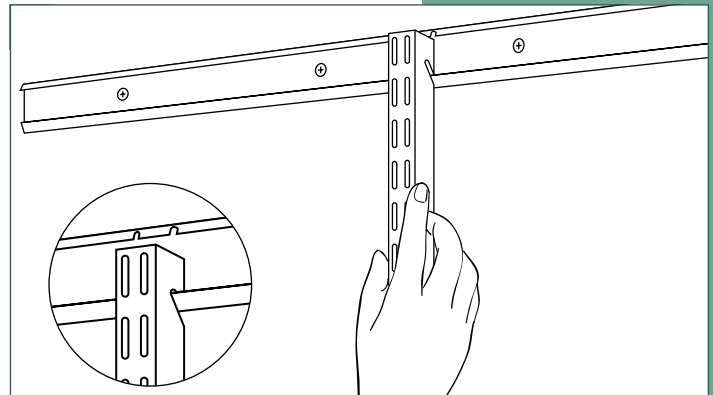
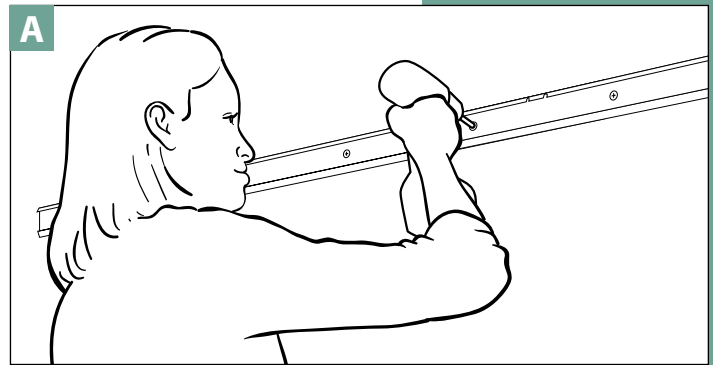

Hanging Drawers, Gliding Accessory Racks, décor Shelves and Fascia

Install the elfa products listed below before installing Ventilated Shelves.

Step 1

Hanging Standard Placement

- Hanging Standards should be placed in position by using the elfa Spacer provided in the package. (Figure A) Refer to your custom space design.

Step 2

Install the U-Shaped Metal Glide

TIP

- elfa décor gliding components and elfa Hanging Drawers are all installed with the same U-Shaped Metal Glide.
- If you would like more space between Drawers, simply move them to the desired position.

The U-Shaped Metal Glide has three metal tabs and a metal knob on each side (located at the top of the glide) that locks the glide into the Bracket.

- Begin with the left Bracket. Align the metal tabs on the U-Shaped Metal Glide with the cutout notches of the Bracket. (Figure B)
- When aligned, hold the front of the bracket and press on the U-Shaped Metal Glide at the back rounded corner until you hear it lock into place. (Figure B)
- Repeat on the right side.

TIP

- **To REPOSITION the U-Shaped Metal Glide:** It is not necessary to remove the glide from the Brackets. Simply tilt up the front of both Brackets and remove them from the Hanging Standards. Place in the desired location.
- **To REMOVE the U-Shaped Metal Glide from the Brackets:** Place one hand at the back of the glide. With your thumb on the Hanging Standard, gently push the glide forward with your fingers. At the same time, insert and twist a small flat head screwdriver between the Bracket and U-Shaped Metal Glide in front of the knob holding the glide in place. The U-Shaped Metal Glide should pop out of the Bracket. Repeat on the other side. (Figure C)

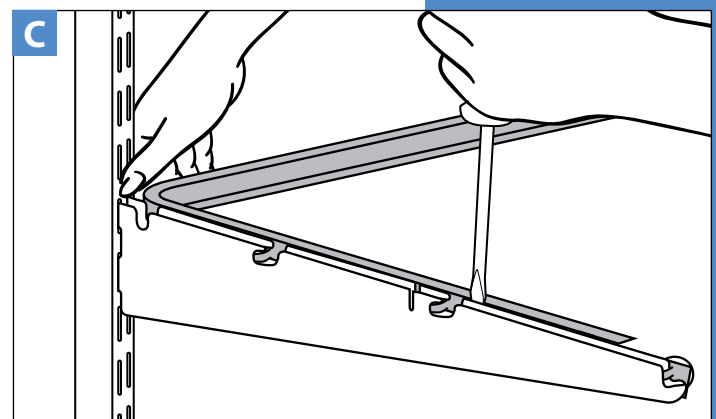
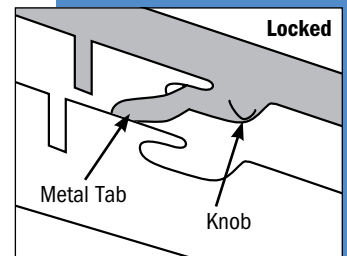
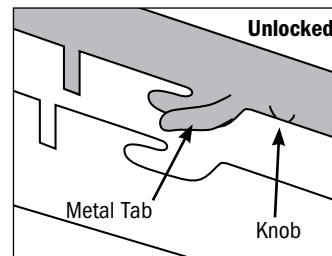
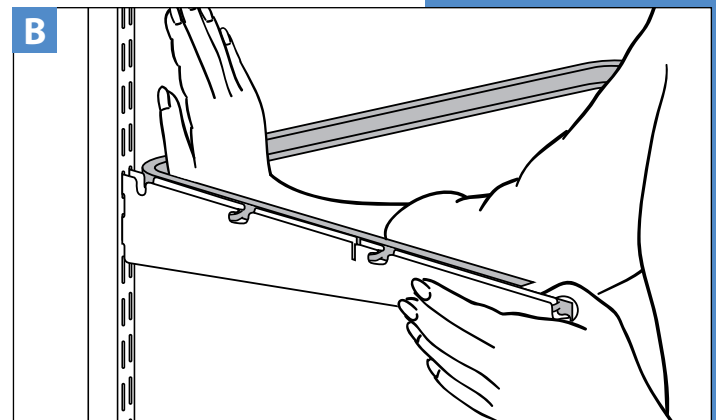
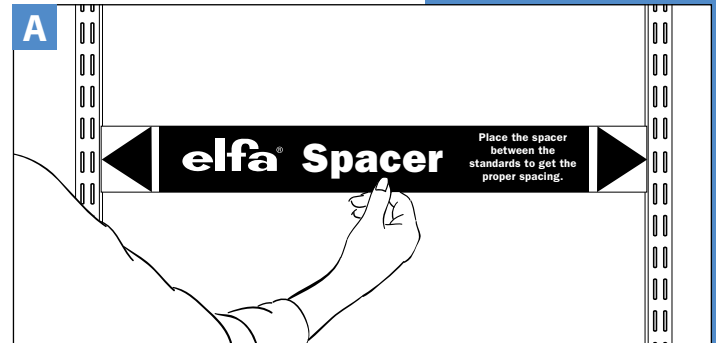

Step 3

Install the Gliding Accessories

- Align the rollers on each side of the frame with the openings in the U-Shaped Metal Glide. Slide the frame into the glide. (Figure D)

Drawers

- Always start with the bottom Drawer and work up.
- For décor Drawers, insert the Drawer into the frame opening and attach it to the left and right side of the wood frame with the Drawer Clips provided. (Figure E)
- For Hanging Drawers, simply insert the Drawer into the frame opening.

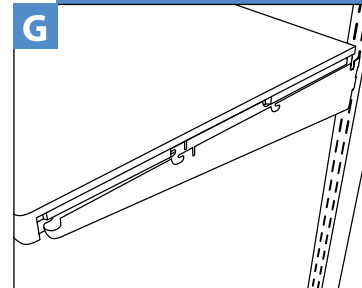
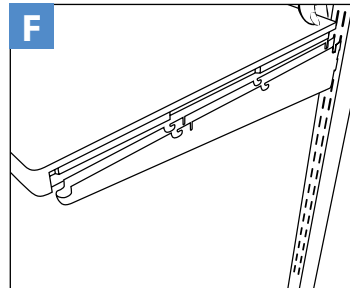
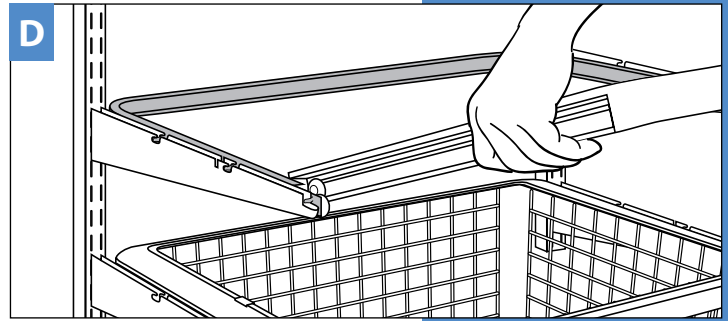
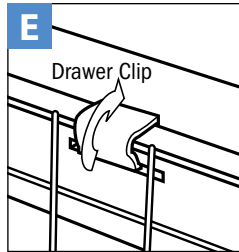

To Install a décor Shelf

- Insert Ventilated Shelf Brackets into the Hanging Standards at the desired height.
- Place the décor Shelf over the Brackets (Figure F) and press down to snap into place. (Figure G)
- Add Bracket Covers.

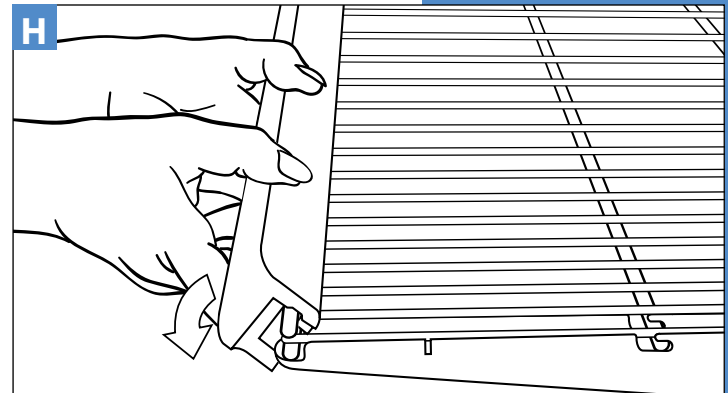

To Install Fascia on Ventilated Shelves

To install Ventilated Shelving without Fascia, go to page 7.

TIP

- Position ALL pieces of Fascia before installing clips.

- Position the Fascia with the opening facing the Ventilated Shelf. (Figure H) The notch in the Fascia that hooks onto the front support wires of the Ventilated Shelf should be at the top. Hook over the top wire with a downward motion, and secure it to the front of the shelf.
- Use the included clips to secure the Fascia to the Ventilated Shelf.
- The top of the clip features a groove that accommodates one shelf wire. (Figure I) Once it's attached to the underside of a shelf wire, slide it all the way to the front of the shelf and into the opening of the Fascia for a secure hold. (Figure J)
- Repeat with another clip at the opposite end of the Fascia. If you are installing a 2' Fascia, add the third clip at the center of the Fascia.

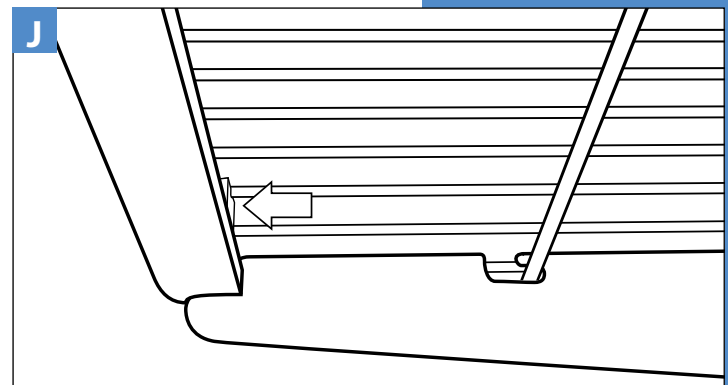
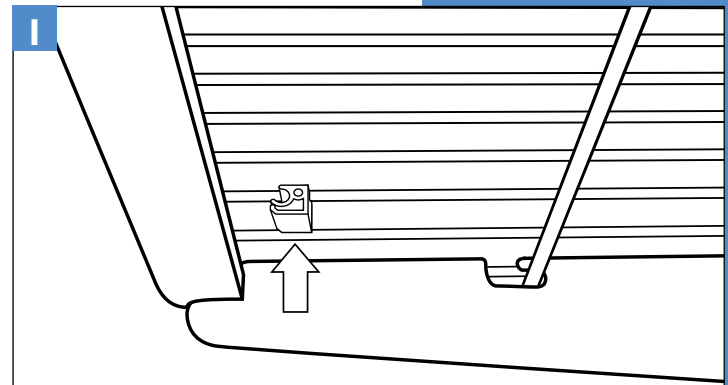

To complete your installation, go to page 7.

Ventilated Shelves and Closet Rods

Step 1 – Install the Ventilated Shelves

TIP

- Install the Ventilated Shelves from shortest to longest, regardless of their location in the space.
- Ventilated Shelves have a top and a bottom. The middle support wire(s) is connected to the bottom of the shelf.

- Place the shelf wires over Shelf Bracket notches. (Figure A)
- Install the shelf with end wires inside the Brackets. (Figure A)
- Lock the shelf into place by pressing down on the middle of the shelf and pushing toward the wall. (Figure A)

To install Fascia, go to page 6.

TIP

- To REPOSITION a Ventilated Shelf after it's been attached to the Brackets: Hold by the Brackets, and lift the front of the shelf toward the ceiling and outward to release the entire unit from the Hanging Standards. (Works on all shelves except 20" depth.)
- To REMOVE a Ventilated Shelf from a Bracket while on the Hanging Standards: Hold the Hanging Standard steady with one hand. Place the other hand at the back of the shelf. Pull up and forward to release.

Step 2 – Install the Shelf Baskets (not shown)

- With the double wire front lip of the Shelf Basket facing forward, place the Shelf Basket wires over the Shelf Bracket notches.
- Install the Shelf Basket with the end wires inside the Bracket.
- Lock the Shelf Basket into place by pressing down on the middle of the Shelf Basket and pushing toward the wall.
- Insert Shelf Basket Dividers where desired, if applicable.

Step 3 – Install the Closet Rod Holders and Rod

- Insert the Closet Rod Holder into the slot in the bottom of the Ventilated Shelf Bracket. (Figure B)
- Tap the End Caps into both ends of the Closet Rod.
- Snap the Closet Rod into the Closet Rod Holder. (Figure C)

Installing Closet Rods That Share a Closet Rod Holder

- First, install joined rods in the center of the Closet Rod Holder, then place the outer ends in the Closet Rod Holder. (Figure D)
- Tap the End Caps only into the non-joined ends of each Closet Rod. Adding End Caps to the joined ends creates a gap.

Step 4 – Bracket Cover Installation

- Left and Right Bracket Covers are not interchangeable.
- Place the outer edge of the Bracket Cover over the outer edge of the Ventilated Shelf Bracket. (Figure E)
- Push down from the back to the front to snap the Bracket Cover in place.

To assemble Drawers and Frames, go to page 12.

To install the Top Track Cover, go to page 4.

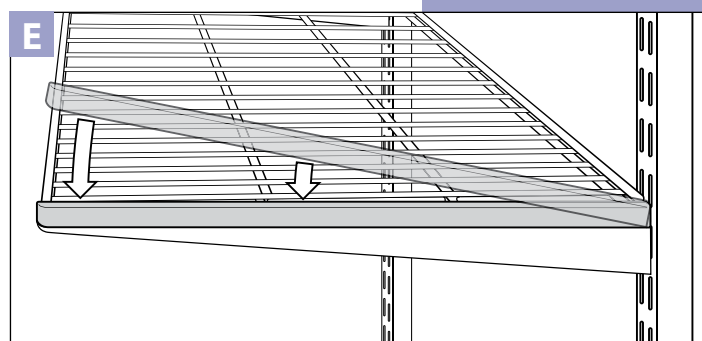
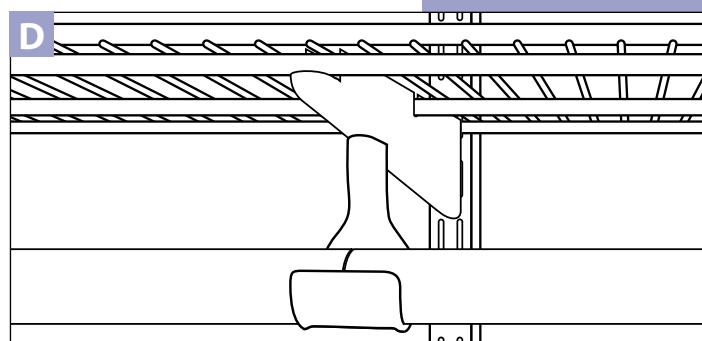
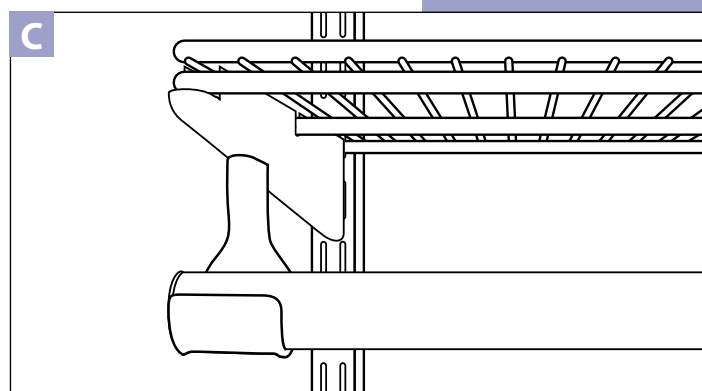
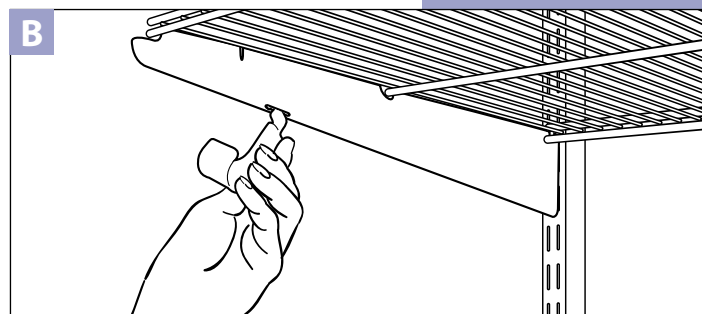
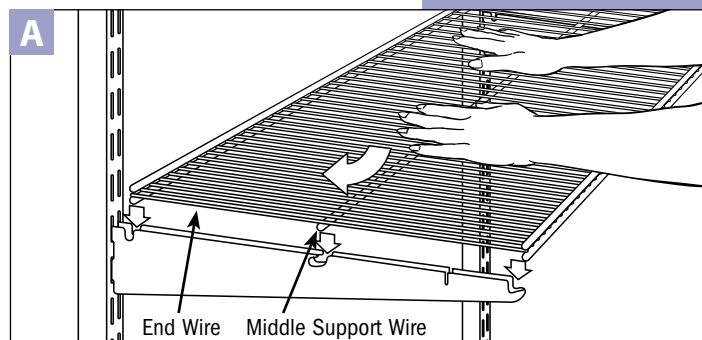

Solid Shelving

Complete the steps on pages 2-4 before installing Solid Shelving.

TIP

- There are drilled holes on the bottom of the Shelf for ease of installation.
- The row of Shelving closest to the middle should be installed first. **(Figure A)**
- Group Shelves by color: 30" Shelves have a blue sticker; 25" End Shelves have a green sticker; 24" Center Shelves have a red sticker. The sticker also indicates the front of the shelf.

Install Connected Shelves

Step 1

- Flip the Shelf upside down to expose the holes with the back of the Shelf toward you.
- Insert the Shelf Connectors as shown. **(Figure B)**

Step 2

- Flip the Shelf right side up and place the Shelf Connectors into the Bracket notches. Connected Shelves share a Bracket.
- (Figure C)**
- After installing the middle row of shelving, repeat Steps 1-2 for each row of Shelves.

To install the Top Track Cover, go to page 4.

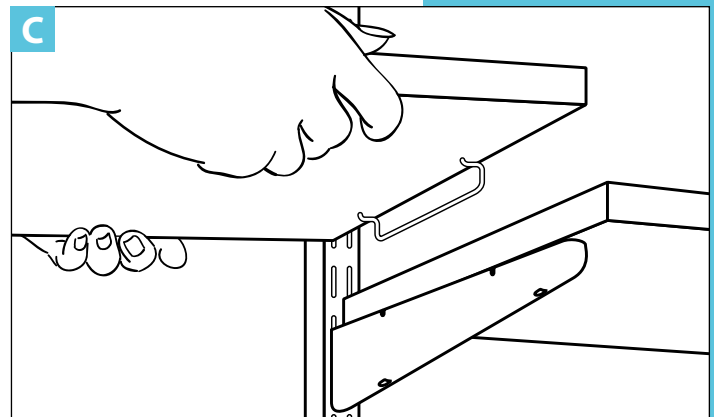
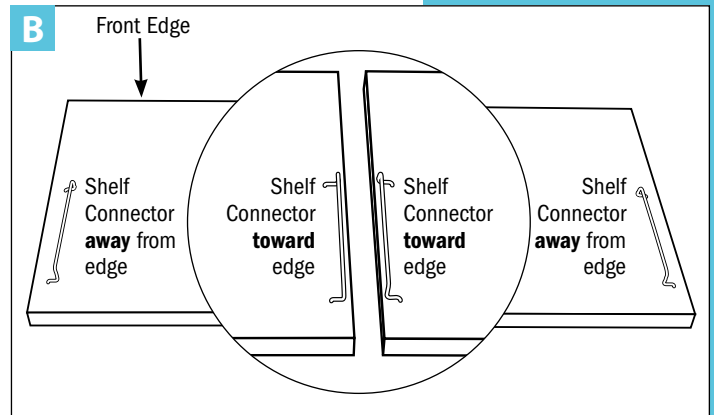
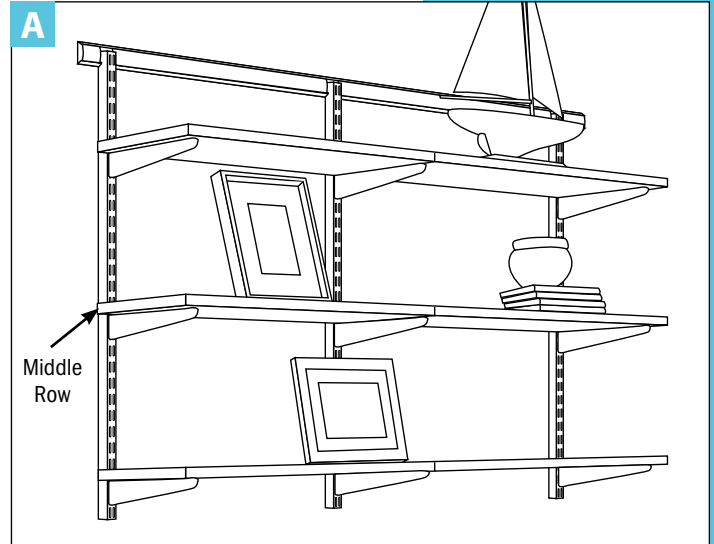

Install Independent Shelves with Connected Shelves (Figure A)

Step 1

- Flip the Shelf upside down to expose the holes, with the back of the Shelf toward you.

Step 2

- Insert Independent Shelf Pins with the arrow to the outside edge of the Shelf.

Step 3

- Flip the Shelf right side up and place the Independent Shelf Pins into the Bracket notches. (Figure B)

To install the Top Track Cover, go to page 4.

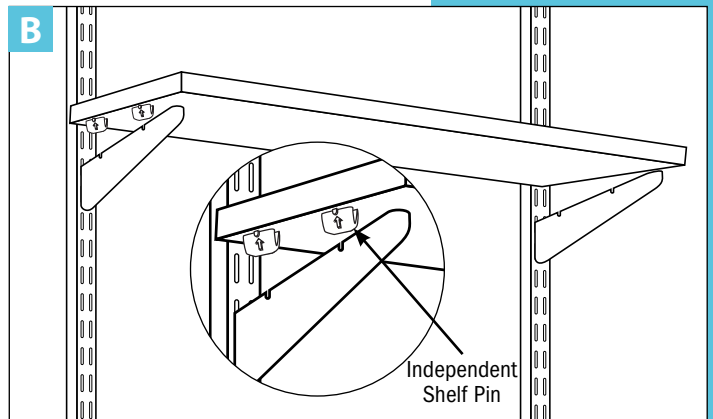
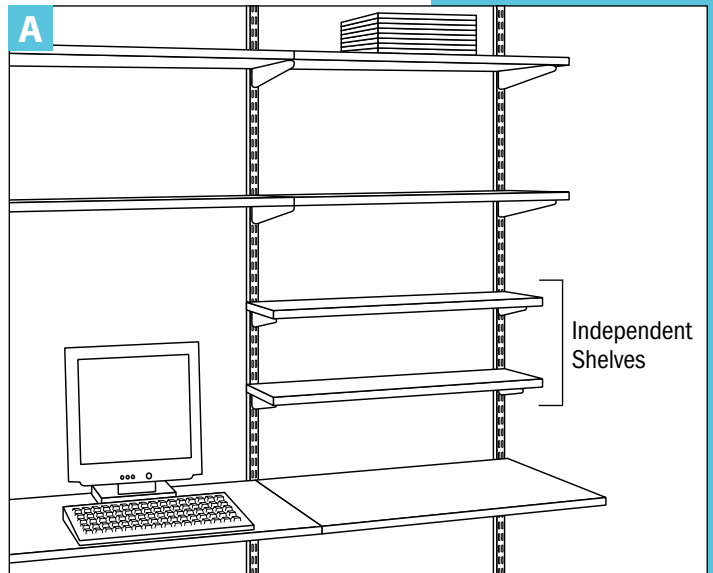

Install a 24" or 30" Section of Shelving (Figure A)

TIP

- There are drilled holes on the bottom of the solid Shelf for ease of installation.
- The row of shelving closest to the middle should be installed first. (Figure A)

Step 1

- Flip the Shelf upside down to expose the holes with the back of the Shelf toward you.
- Insert the Shelf Connectors as shown. (Figure B)

Step 2

- Flip the Shelf right side up and place the Shelf Connectors into the Bracket notches. (Figure C)
- Repeat for the remaining Shelves.

Installing Using Shelf Screws

(not shown)

Additional tool needed: awl (or similar pointed tool)

TIP

- Shelf Screws are an alternative to using Shelf Connectors. They are used with Desk Tops and on rare occasions with Shelves when it is necessary for the Shelves to remain fixed.

Step 1

- Place the Desktop on the Brackets and use a pencil to trace an outline of the Brackets.

Step 2

- Take the Desktop off the Brackets and flip it upside down on a solid surface with pencil marks visible.

Step 3

- Take a Bracket out of a Hanging Standard to use as a guide. Place the Bracket over each Bracket outline on the Desktop and use an awl to punch a mark for the screws through each hole in the Bracket. Be sure to keep the awl straight.

Step 4

- Remove the Bracket and use a 1/8" drill bit to drill a hole at each punch mark.

Step 5

- Place the Desktop on the Brackets and align the holes in the Shelf with the corresponding Shelf Bracket holes.

Step 6

- Insert the shorter screw in the front hole and the longer screw in the back hole of each Bracket.
- Tighten each screw with a #2 Phillips head screwdriver.

To install the Top Track Cover, go to page 4.

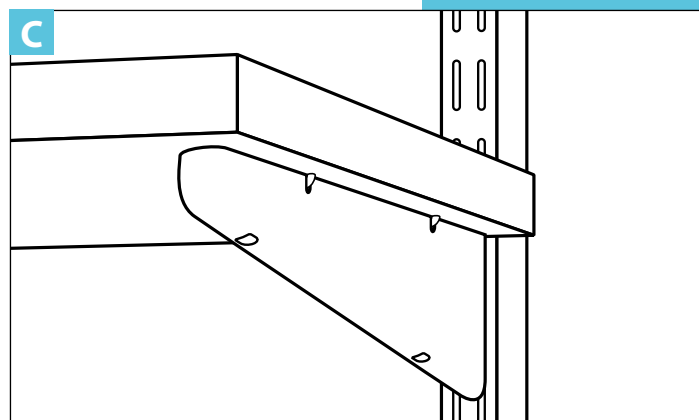
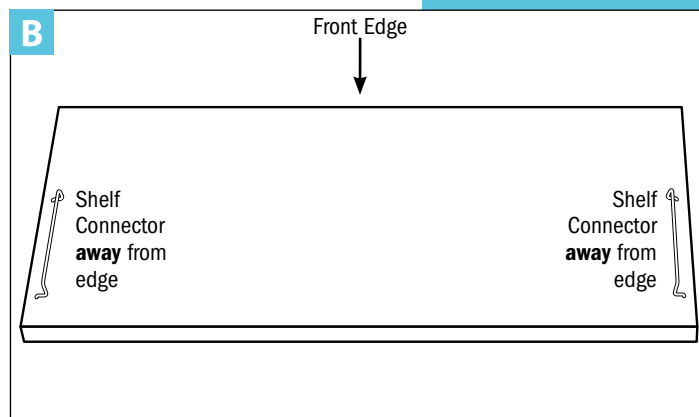
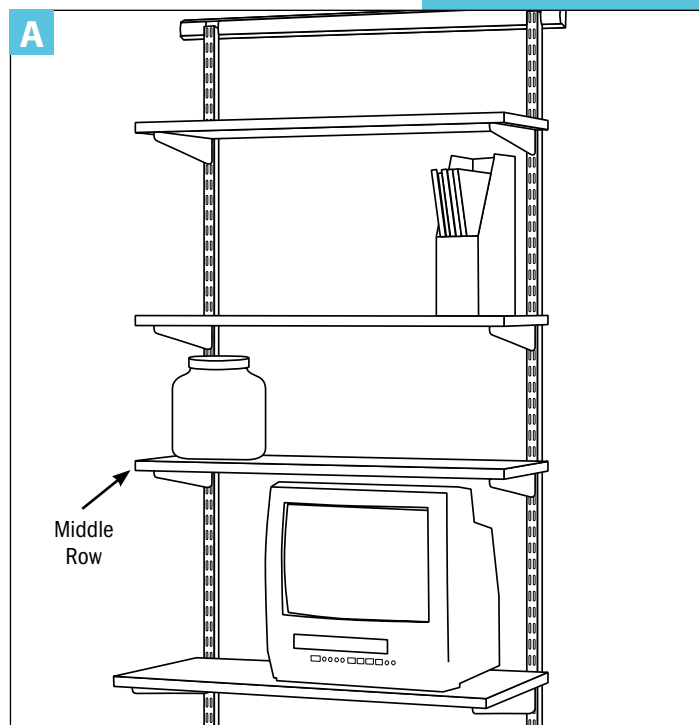

Wall-Mounted Standards

Tools needed: level, power drill, drill bits, #2 Phillips head bit for a power drill, hammer, ladder or step stool

TIP

- **Mounting Standards in a Corner:** Install the Standard approximately 2" from the corner to allow enough room for the drill or screwdriver.

Step 1

- Position one Standard where you want it on the wall.
- Mark the position of the second screw hole from the top of the Standard.

Step 2

- Drill a hole with a 1/8" drill bit.
- If you hit wood, continue drilling the entire length of the drill bit. If you hit the hollow part of the wall, enlarge the hole with the appropriate drill bit size for the type of hardware needed for your wall surface (see page 3).
- If using a drywall anchor or plaster anchor, do not remove the grey spacer.
- Screw the Standard loosely into place.

Step 3

- Using a level, check that the Standard is straight.

Step 4

- Mark and drill the remaining holes and install all of the screws and necessary anchors.

Step 5

- To install the next Standard, measure and mark out a suitable distance between the two Standards, based on your custom design.

Step 6

- While holding the unattached Standard to the wall, place a Shelf on the Brackets. Adjust the spacing as needed and check that the Shelf is level.

Step 7

- Mark, then drill, the remaining holes and screw the second Standard into place as in Step 2. Repeat for each Standard.

To install Ventilated Shelving, go to page 7.

To install Solid Shelving, go to page 8.

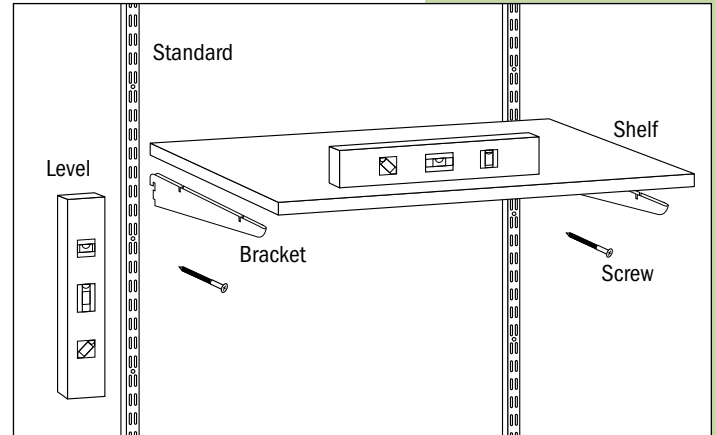

Drawer Units

(Figure A)

Tool needed: plastic mallet

TIP

- If you don't have a plastic mallet, you can use a hammer with a wood block to protect the frame.

Step 1

- Position the side panels so the frame runners face inward.
- Using a plastic mallet, tap the bottom T-crossbars into the bottom of each side panel.

Step 2

- If using Back Stop Pins, install them in the back holes of the top runners before inserting the top L-crossbars. The remaining Back Stop Pins should be put in just prior to sliding in the Drawers.

If combining Frames, see Figure B below.

Step 3

- **If using a Melamine Top**, tap the top L-crossbars completely into each side panel. Place adhesive strips included in the packaging on the top L-Crossbars. Align the Melamine Top with the crossbars and press firmly.
- **If using a Butcher Block Top**, tap the top L-crossbars completely into each side panel. Place the Butcher Block Top on the crossbars.

Step 4

- Insert remaining Back Stop Pins.
- Slide in Drawers.
- If you have other elfa Frame and Drawer accessories, install them now.

Combining Drawer Units

(Figure B)

Step 1

- Assemble the top frame completely. See Steps 1-2 above.

Step 2

- Assemble the bottom frame, omitting the top L-crossbars.
- If using Back Stop Pins, insert them in the back holes of the left and right top runners of the bottom frame.

Step 3

- Lower the top frame onto the bottom frame, making sure the Back Stop Pins are all on the back side. Secure by firmly tapping each corner of the top frame until the bottom T-crossbars are completely inserted into the bottom frame.

Step 4

- Insert the remaining Back Stop Pins.
- Slide in Drawers.
- If you have other elfa Frame and Drawer accessories, install them now.

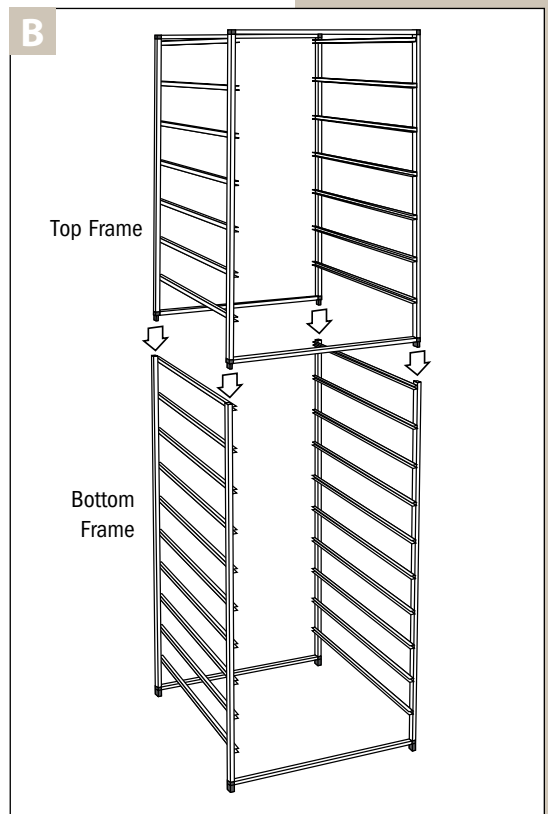
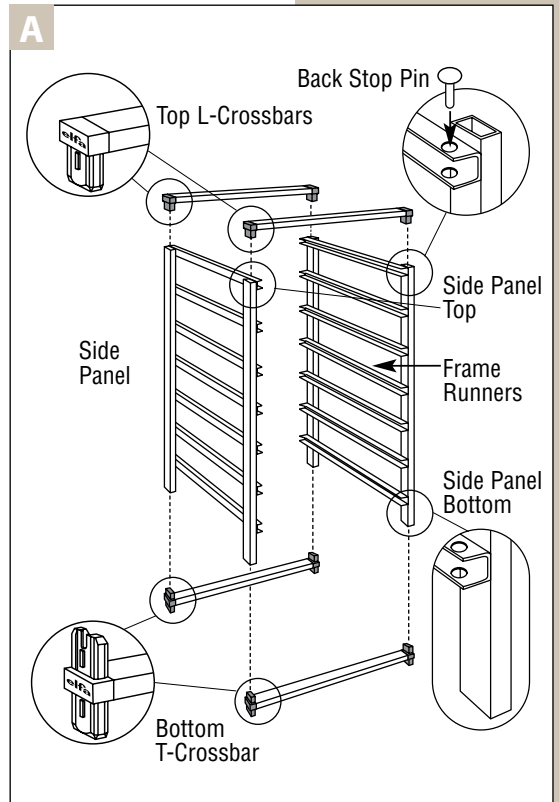

elfa[®]

Installation Service

Save Time. Let Us Do the Work for You! Our time-saving elfa Installation Service is available in all our stores. Visit containerstore.com/installationservice for details.

elfa Instructions for Easy Installation & Assembly and video instructions are also available online at containerstore.com/installation.