

Rosemount™ 3144P Temperature Transmitters

with FOUNDATION™ Fieldbus Protocol



Contents

About this guide..... 3

Mount the transmitter.....5

Wire and apply power..... 7

Verify tagging..... 12

Product certifications..... 17

1 About this guide

This guide provides basic guidelines for installing the Rosemount 3144P Transmitter. It does not provide instructions for detailed configuration, diagnostics, maintenance, service, troubleshooting, Explosion-proof, Flameproof, or intrinsically safe (I.S.) installations. Refer to the Rosemount 3144P Transmitter [Reference Manual](#) for more instructions. The manual and this guide are also available electronically on [Emerson.com/Rosemount](https://www.emerson.com/Rosemount).

⚠ WARNING

Explosions

Explosions could result in death or serious injury.

Installation of device in an explosive environment must be in accordance with appropriate local, national, and international standards, codes, and practices.

Review the Product Certifications section of this document for any restrictions associated with a safe installation.

In an Explosion-proof/Flameproof installation, do not remove the transmitter covers when power is applied to the unit.

Process leaks

Process leaks may cause harm or result in death.

Before applying pressure, install and tighten thermowells and sensors.

Do not remove the thermowell while in operation.

Conduit/cable entries

The conduit/cable entries in the transmitter housing use a ½–14 NPT thread form.

When installing in a hazardous location, use only appropriately listed or Ex-certified plugs, glands, or adapters in cable/conduit entries.

Electrical shock

Electrical shock can result in death or serious injury.

Avoid contact with the leads and terminals. High voltage that may be present on leads could cause electrical shock.

⚠ WARNING**Physical access**

Unauthorized personnel may potentially cause significant damage to and/or misconfiguration of end users' equipment. This could be intentional or unintentional and needs to be protected against.

Physical security is an important part of any security program and fundamental in protecting your system. Restrict physical access by unauthorized personnel to protect end users' assets. This is true for all systems used within the facility.

⚠ WARNING

Refer to the *Product certifications* section of this Quick Start Guide documentation when using the RFID tag (option code Y3) for required installation conditions.

2 Mount the transmitter

Mount the transmitter at a high point in the conduit run to prevent moisture from draining into the transmitter housing.

2.1 Typical North American installation

Procedure

1. Mount the thermowell to the process container wall.
2. Install and tighten thermowells.
3. Perform a leak check.
4. Attach any necessary unions, couplings, and extension fittings. Seal the fitting threads with an approved thread sealant, such as silicone or PTFE tape (if required).
5. Screw the sensor into the thermowell or directly into the process (depending on installation requirements).
6. Verify all sealing requirements.
7. Attach the transmitter to the thermowell/sensor assembly. Seal all threads with an approved thread sealant, such as silicone or PTFE tape (if required).
8. Install field wiring conduit into the open transmitter conduit entry (for remote-mounting) and feed wires into the transmitter housing.
9. Pull the field wiring leads into the terminal side of the housing.
10. Attach the sensor leads to the transmitter sensor terminals. The wiring diagram is located inside the housing cover.
11. Attach and tighten both transmitter covers.

2.2 Typical European installation

Procedure

1. Mount the thermowell to the process container wall.
2. Install and tighten thermowells.
3. Perform a leak check.
4. Attach a connection head to the thermowell.
5. Insert sensor into the thermowell and wire the sensor to the connection head. The wiring diagram is located inside the connection head.

6. Mount the transmitter to a 2-in. (50 mm) pipe or a panel using one of the optional mounting brackets.
7. Attach cable glands to the shielded cable running from the connection head to the transmitter conduit entry.
8. Run the shielded cable from the opposite conduit entry on the transmitter back to the control room.
9. Insert shielded cable leads through the cable entries into the connection head/transmitter. Connect and tighten cable glands.
10. Connect the shielded cable leads to the connection head terminals (located inside the connection head) and to the sensor wiring terminals (located inside the transmitter housing).

3 Wire and apply power

3.1 Wire the transmitter

Table 3-1: Single sensor

2-wire RTD and ohms	3-wire RTD and ohms ⁽¹⁾	4-wire RTD and ohms	Thermocouples and mV	RTD with compensation loop ⁽²⁾

- (1) Emerson provides four-wire sensors for all single-element RTDs. You can use these RTDs in three-wire configurations by leaving the unneeded leads disconnected and insulated with electrical tape.
- (2) Transmitter must be configured for a three-wire RTD in order to recognize an RTD with a compensation loop.

Table 3-2: Dual sensor

Emerson provides four-wire sensors for all single-element RTDs. To use these RTDs in three-wire configurations, leave the unneeded leads disconnected and insulated with electrical tape. This table refers to wiring dual sensors for ΔT and Hot Backup™.

With 2 RTDs	With 2 thermocouples	With RTDs/ thermocouples	With RTDs/ thermocouples	With 2 RTDs with compensation loop

3.2 Power the transmitter

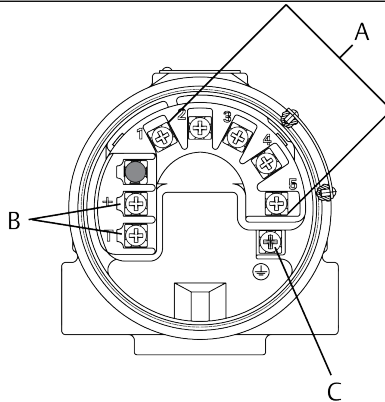

- A. Sensor terminals (1-5)
- B. Power terminals
- C. Ground

Procedure

1. Remove the terminal block cover.
2. Connect power to the power terminal.
The terminals are polarity insensitive.
3. Tighten the terminal screws.
4. Reattach and tighten the cover.

⚠ WARNING

Enclosure

Enclosure covers must be fully engaged to meet explosion-proof requirements.

5. Apply power.

3.3 Ground the transmitter

3.3.1 Ungrounded thermocouple, mV, and RTD/ohm inputs

Each process installation has different requirements for grounding. Use the grounding options recommended by the facility for the

specific sensor type or begin with grounding option 1 (the most common).

Ground the transmitter: option 1

Emerson recommends this option for ungrounded transmitter housing.

Procedure

1. Connect signal wiring shield to the sensor wiring shield.
2. Ensure the two shields are tied together and electrically isolated from the transmitter housing.
3. Ground shield at the power supply end only.
4. Ensure that the sensor shield is electrically isolated from the surrounding grounded fixtures.
5. Connect shields together, electrically isolated from the transmitter.

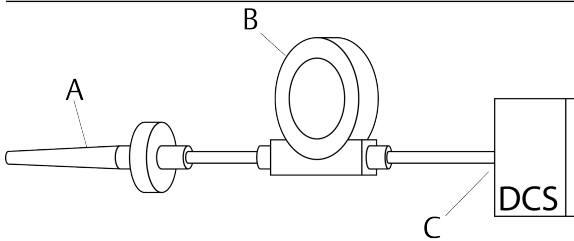

- A. *Sensor wire*
 B. *Transmitter*
 C. *Shield ground point*

Ground the transmitter: option 2

Emerson recommends this method for grounded transmitter housing.

Procedure

1. Connect sensor wiring shield to the transmitter housing.
Do this only if the housing is grounded.
2. Ensure that the sensor is electrically isolated from surrounding fixtures that may be grounded.
3. Ground signal wiring shield at the power supply end.

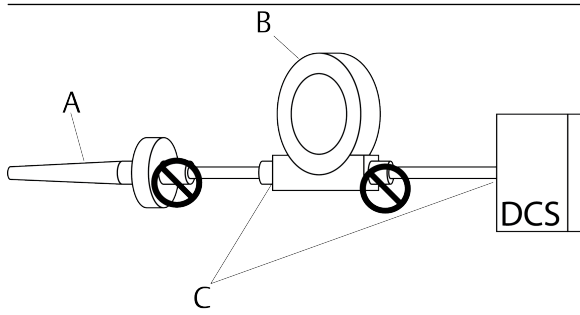

- A. Sensor wire
- B. Transmitter
- C. Shield ground point

Ground the transmitter: option 3

Procedure

1. Ground sensor wiring shield at the sensor, if possible.
2. Ensure the sensor wiring and signal wiring shields are electrically isolated from the transmitter housing and other grounded fixtures.
3. Ground signal wiring shield at the power supply end.

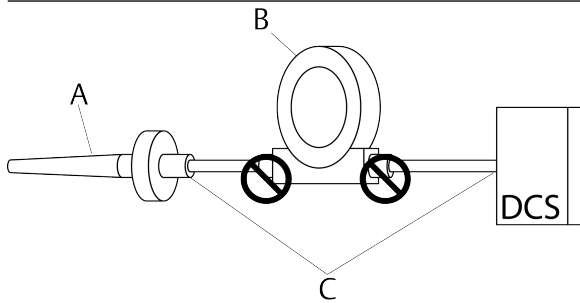

- A. Sensor wire
- B. Transmitter
- C. Shield ground point

3.3.2 Ground thermocouple inputs

Procedure

1. Ground sensor wiring shield at the sensor.

2. Ensure the sensor wiring and signal wiring shields are electrically isolated from the transmitter housing and other grounded fixtures.
3. Ground signal wiring shield at the power supply end.

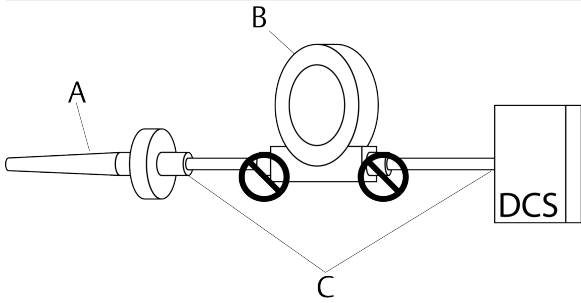

- A. Sensor wire
 - B. Transmitter
 - C. Shield ground point
-

4 Verify tagging

4.1 Commissioning (paper) tag

To identify which device is at a particular location use the removable tag provided with the transmitter. Ensure the physical device tag (PD Tag field) is properly entered in both places on the removable commissioning tag and tear off the bottom portion for each transmitter.

COMMISSIONING TAG

Device ID:
0011513051010001440-121698091725

PD Tag:
TT- 101

Revision: 7.2

— — — **Tear Here** — — —

Revision: 7.2

Support files available at
www.rosemount.com

Device Serial
Number:
XXXXXXXXXX

Device ID:
0011513051010001440-121698091725

PD Tag:
TT- 101

Note

The device description loaded in the host system must be at the same revision as this device. You can download the device description from Emerson.com/Rosemount.

4.1.1 Verify transmitter configuration

Each FOUNDATION Fieldbus host or configuration tool has a different way of displaying and performing configurations. Some use Device Descriptions (DD) or DD methods for configuration and to display data consistently across platforms. There is no requirement that a host or configuration tool support these features.

The following is the minimum configuration requirement for a temperature measurement. This guide is designed for systems not using DD methods. For a complete list of parameters and configuration information, refer to the [Rosemount 3144P Temperature Transmitter Reference Manual](#).

4.2 Transducer function block

This block contains temperature measurement data for the sensors and the terminal temperature. It also includes information about sensor types, engineering units, damping, and diagnostics.

At a minimum, verify the parameters in [Table 4-1](#).

Table 4-1: Transducer Block Parameters

Parameter	Comments
Typical configuration	
SENSOR_TYPE_X	Example: "Pt 100_A_385 (IEC 751)"
SENSOR_CONNECTIONS_X	Example: "2-wire", "3-wire", "4-wire"
Sensor matching configuration	
SENSOR_TYPE_X	"User Defined, Calvandu"
SENSOR_CONNECTIONS_X	Example: "2-wire", "3-wire", "4-wire"
SENSOR_CAL_METHOD_X	Set to "User Trim Standard"
SPECIAL_SENSOR_A_X	Enter sensor specific coefficients
SPECIAL_SENSOR_B_X	Enter sensor specific coefficients
SPECIAL_SENSOR_C_X	Enter sensor specific coefficients
SPECIAL_SENSOR_R0_X	Enter sensor specific coefficients

4.2.1 Analog Input (AI) function block

The AI block processes field device measurements and makes the outputs available to other function blocks. The output value of the AI block is in engineering units and contains a status indicating the quality of the measurements. Use the channel number to define the variable that the AI block processes.

At a minimum, verify the parameters of each AI block in [Table 4-2](#).

Note

All devices ship with the AI blocks scheduled, meaning the operator does not need to configure the block or he or she uses factory default channels.

Table 4-2: AI Block Parameters

Configure one AI Block for each desired measurement.

Parameter	Comments
CHANNEL	Choices: <ol style="list-style-type: none"> 1. Sensor 1 Temperature 2. Sensor 2 Temperature 3. Differential Temperature 4. Terminal Temperature 5. Sensor 1 Min. Value 6. Sensor 1 Max. Value 7. Sensor 2 Min. Value 8. Sensor 2 Max. Value 9. Differential Min. Value 10. Differential Max. Value 11. Terminal Temp Min. Value 12. Terminal Temp Max. Value 13. Hot Backup
LIN_TYPE	This parameter defines the relationship between the block input and the block output. Since the transmitter does not require linearization, this parameter will always be set to No Linearization. This means that the AI block will only apply scaling, filtering, and limit checking to the input value.
XD_SCALE	Set desired measurement range and units. Units must be one of the following: <ul style="list-style-type: none"> • mV • Ohms • °C • °F • °R • K
OUT_SCALE	For "DIRECT" L_TYPE , set OUT_SCALE to match XD_SCALE

Table 4-2: AI Block Parameters (continued)

Parameter	Comments
HI_HI_LIM HI_LIM LO_LIM LO_LO_LIM	Process alarms. Must be within the range defined by "OUT_SCALE"

Note

To make changes to the AI block, set the **BLOCK_MODE (TARGET)** to **OOS** (Out of Service). After making the changes, return the **BLOCK_MODE TARGET** to **AUTO**.

4.2.2 Set switches

The security and simulate switches are located on the top center of the electronics module.

Note

The factory ships the simulate switch in the "ON" position.

Set the switches with an LCD display

Procedure

1. Set the loop to manual (if applicable) and disconnect the power.
2. Remove the electronics housing cover.
3. Unscrew the LCD display screws and gently slide the meter straight off.
4. Set the alarm and security switches to the desired position.
5. Gently slide the LCD display back into place.
6. Replace and tighten the LCD display screws to secure the LCD display.
7. Reattach housing cover.
8. Apply power and set the loop to automatic control.

Set the switches without an LCD display

Procedure

1. Set the loop to manual (if applicable) and disconnect the power.
2. Remove the electronics housing cover.
3. Set the alarm and security switches to the desired position.
4. Reattach housing cover.

5. Apply power and set the loop to automatic control.

5 Product certifications

5.1 European Directive information

A copy of the EU Declaration of Conformity can be found at the end of this guide. The most recent revision of the EU Declaration of Conformity can be found at [Emerson.com/Rosemount](https://www.emerson.com/Rosemount).

5.2 Ordinary location certification

As standard, the device has been examined and tested to determine that the design meets the basic electrical, mechanical, and fire protection requirements by a nationally recognized test laboratory (NRTL) as accredited by the Federal Occupational Safety and Health Administration (OSHA).

5.3 North America

5.3.1 E5 USA Explosionproof, Dust-Ignition proof, and Nonincendive

Certificate FM16US0202X

Standards FM Class 3600: 2018, FM Class 3611:2004, FM Class 3615:2018, FM Class 3616: 2011, FM Class 3810:2018, ANSI/ISA 60079-0:2009, ANSI/NEMA 250:1991

Markings **XP** CL I, DIV 1, GP A, B, C, D; T5
DIP CL II, DIV 1, GP E, F, G; CL III; T5
NI CL I, DIV 2, GP A, B, C, D; T5
 (-50 °C ≤ T_a ≤ +85 °C); when installed per Rosemount drawing 03144-0320; Type 4X

5.3.2 I5 USA Intrinsic Safety and Nonincendive

Certificate 1242650

Standards FM3600: 2018, FM3611: 2021, FM3615: 1989, FM3616: 2011, UL61010-1-2019 Third Edition, ANSI/UL60079-0: 2020, ANSI/UL60079-11: 2013, ANSI/UL50E (Third Edition).

Markings **IS** CL I, DIV 1, GP A, B, C, D; T4, CL II DIV 1, GP E, F, G; CL III; T4, CL 1, Zone 0, AEx ia IIC T4 Ga; Zone 20 AEx ia IIIC T94 °C Da; T4 (-50 °C ≤ T_a ≤ +60 °C)
NI CL I, DIV 2, GP A, B, C, D; (-60 °C ≤ T_a ≤ +85 °C)
 when installed per Rosemount drawing 03144-5076; Type 4X

5.3.3 I6 Canada Intrinsic Safety and Division 2

Certificate 1242650

Standards C22.2 No. 61010-1-12 + UPD1: 2015 + UPD2: 2016, C22.2 No. 25-17, C22.2 No.94.2-20 Third Edition, CSA Std C22.2 No. 213-17, CAN/CSA-60079-0:19, CAN/CSA-60079-11:14

Markings **IS** CL I DIV 1, GP A, B, C, D; T4, CL II DIV 1, GP E, F, G; CL III; T4 Ex ia IIC T4 Ga; Ex ia IIIC T94 °C Da; T4 (-50 °C ≤ T_a ≤ +60 °C)

NI CL I DIV 2, GP A, B, C, D (-60 °C ≤ T_a ≤ +85 °C)
when installed per Rosemount drawing 03144-5076;
Type 4X

5.3.4 K6 Canada Explosionproof, Intrinsic Safety and Division 2

Certificate 1242650

Standards C22.2 No. 61010-1-12 + UPD1: 2015 + UPD2: 2016, C22.2 No. 25-17, C22.2 No.94.2-20 Third Edition, CSA Std C22.2 No. 213-17, CAN/CSA-60079-0:19, CAN/CSA-60079-11:14, CSA Std C22.2 No. 30-M1986

Markings **XP** CL 1 DIV 1, GP A, B, C, D

DIP CL II DIV 1, GP E, F, G; CL III;
(-50 °C ≤ T_a ≤ +85 °C); Type 4X; seal not required.

5.4 Europe

5.4.1 E1 ATEX Flameproof

Certificate DEKRA 19ATEX0076 X

Standards EN IEC 60079-0: 2018, EN 60079-1: 2014, EN 60079-31:2014

Markings  II 2 G Ex db IIC T6...T1 Gb, T6(-60 °C ≤ T_a ≤ +70 °C), T5...T1(-60 °C ≤ T_a ≤ +80 °C)

Specific Conditions of Use (X):

1. Flameproof joints are not intended for repair.
2. Non-standard paint options may cause risk from electrostatic discharge. Avoid installations that cause electrostatic build-up on painted surfaces and only clean the painted surfaces with a damp cloth. If paint is ordered through a special option code, contact the manufacturer for more information.

3. See instructions for relation between process temperature, ambient temperature, and temperature class/ maximum surface temperature "T".
4. For 3144P temperature transmitters with "XA" designation, the spring-loaded adapter style sensors must be installed in a thermowell to maintain Ex tb protection.

Process temperature range at sensor connection ⁽¹⁾ (°C).	Ambient temperature range (°C)	Temperature class
-60 °C to +70 °C	-60 °C to +70 °C	T6
-60 °C to +80 °C	-60 °C to +80 °C	T5...T1

(1) Sensor connection is where the sensor threads into the transmitter or junction box housing

5.4.2 I1 ATEX Intrinsic Safety

Certificate Baseefa03ATEX0708X

Standards EN IEC 60079-0: 2018; EN 60079-11:2012

Markings  II 1 G Ex ia IIC T4 Ga; T4(-60 °C ≤ T_a ≤ +60 °C)
See [Table 5-4](#) for entity parameters.

Special Conditions for Safe Use (X):

1. When fitted with the transient terminal options, the equipment is not capable of passing the 500 V insulation test. This must be taken into account during installation.
2. The enclosure may be made from aluminum alloy with a protective polyurethane paint finish; however, care should be taken to protect it from impact or abrasion when located in Zone 0.

5.4.3 N1 ATEX Type n

Certificate Baseefa03ATEX0709X

Standards EN IEC 60079-0:2018, EN 60079-15:2010, EN IEC 60079-7:2015+A1: 2018

Markings  II 3 G Ex ec IIC T5 Gc; T5(-40 °C ≤ T_a ≤ +75 °C); Ex nA IIC T5 Gc; T5(-40 °C ≤ T_a ≤ +75 °C)

Special Condition for Safe Use (X):

When fitted with transient terminal options, the equipment is not capable of withstanding the 500V insulation test required by EN 60079-7 or EN 60079-15. This must be taken into account when installing the equipment.

5.4.4 ND ATEX Dust

Certificate DEKRA 19ATEX0076 X

Standards EN IEC 60079-0:2018, EN 60079-1:2014, EN 60079-31:2014

Markings  II 2 D Ex tb IIIC T130 °C Db, (-60 °C ≤ T_a ≤ +80 °C)

Specific Condition of Use (X):

1. Flameproof joints are not intended for repair.
2. Non-standard paint options may cause risk from electrostatic discharge. Avoid installations that could cause electrostatic build-up on painted surfaces, and only clean the painted surfaces with a damp cloth. If paint is ordered through a special option code, contact the manufacturer for more information.
3. See instructions for relation between process temperature, ambient temperature, and temperature class/ maximum surface temperature "T".
4. For 3144P temperature transmitters with "XA" designation, the spring-loaded adapter style sensors must be installed in a thermowell to maintain Ex tb protection.

Process temperature range at sensor connection ⁽¹⁾ (°C).	Ambient temperature range (°C)	Maximum surface temperature "T"
-60 °C to +80 °C	-60 °C to +80 °C	T130 °C

(1) Sensor connection is where the sensor threads into the transmitter or junction box housing

5.5 International

5.5.1 E7 IECEx Flameproof

Certificate IECEx DEK 19.0041X

Standards IEC 60079-0:2017, IEC 60079-1:2014-06

Markings Ex db IIC T6...T1 Gb, T6(-60 °C ≤ T_a ≤ +70 °C), T5...T1(-60 °C ≤ T_a ≤ +80 °C)

Specific Conditions of Use (X):

1. Flameproof joints are not intended for repair.
2. Non-Standard paint options may cause risk from electrostatic discharge. Avoid installations that cause electrostatic build-up on painted surfaces, and only clean the painted surfaces with a damp cloth. If paint is ordered through a special option code, contact the manufacturer for more information.
3. See instructions for relation between process temperature, ambient temperature, and temperature class/ maximum surface temperature "T".
4. For 3144P temperature transmitters with "XA" designation, the spring-loaded adapter style sensors must be installed in a thermowell to maintain Ex tb protection.

Process temperature range at Sensor Connection ⁽¹⁾ (°C)	Ambient temperature range (°C)	Temperature class
-60 °C to +70 °C	-60 °C to +70 °C	T6
-60 °C to +80 °C	-60 °C to +80 °C	T5...T1

(1) *Sensor Connection is where the sensor threads into the transmitter or junction box housing.*

Additionally Available with Option K7:

IECEX Dust

Certificate IECEx DEK 19.0041X
Standards IEC 60079-0:2017 and IEC 60079-31:2013
Markings Ex tb IIIC T130 °C Db, (-60 °C ≤ T_a ≤ +80 °C)

Specific Conditions of Use (X):

1. Flameproof joints are not intended for repair.
2. Non-Standard paint options may cause risk from electrostatic discharge. Avoid installations that cause electrostatic build-up on painted surfaces, and only clean the painted surfaces with a damp cloth. If paint is ordered through a special option code, contact the manufacturer for more information.

3. See instructions for relation between process temperature, ambient temperature, and temperature class/ maximum surface temperature "T".
4. For 3144P temperature transmitters with "XA" designation, the spring-loaded adapter style sensors must be installed in a thermowell to maintain Ex tb protection.

Process temperature range at Sensor Connection ⁽¹⁾ (°C)	Ambient Temperature Range (°C)	Maximum surface temperature "T"
-60 °C to +80 °C	-60 °C to +80 °C	T130 °C

(1) *Sensor Connection is where the sensor threads into the transmitter or junction box housing.*

5.5.2 I7 IECEx Intrinsic Safety

Certificate	IECEX BAS 07.0004X
Standards	IEC 60079-0: 2017; IEC 60079-11: 2011
Markings	Ex ia IIC T4 Ga; T4(-60 °C ≤ T _a ≤ +60 °C) See Table 5-4 for entity parameters.

Special Conditions for Safe Use (X):

1. When fitted with the transient terminal options, the apparatus is not capable of withstanding the 500 V electrical strength test as defined in Clause 6.3.13 of IEC 60079-11: 2011. This must be taken into account during installation.
2. The enclosure may be made from aluminum alloy with a protective polyurethane paint finish; however, care should be taken to protect it from impact or abrasion when located in Zone 0.

5.5.3 N7 IECEx Type n

Certificate	IECEX BAS 07.0005X
Standards	IEC 60079-0:2017, IEC 60079-15:2010; IEC 60079-7:2017
Markings	Ex nA IIC T5 Gc; T5(-40 °C ≤ T _a ≤ +75 °C); Ex ec IIC T5 Gc; T5 (-40°C ≤ T _a ≤ +75°C)

Special Condition for Safe Use (X):

When fitted with the transient terminal options, the apparatus is not capable of withstanding the 500V electrical strength test as defined in

Clause 6.5.1 of IEC 60079-15: 2010 or Clause 6.1 of IEC 60079-7:2017. This must be taken into account during installation.

5.6 Brazil

5.6.1 E2 INMETRO Flameproof and Dust

Certificate UL-BR 21.1296X

Standards ABNT NBR IEC 60079-0:2020; ABNT NBR IEC 60079-1:2016; ABNT NBR IEC 60079-31:2014

Markings Ex db IIC T6...T1 Gb; T6 (-60 °C ≤ T_a ≤ +70 °C); T5...T1 (-60 °C ≤ T_a ≤ +80 °C)
Ex tb IIIC T130 °C Db; (-60 °C ≤ T_a ≤ +80 °C)

Special Conditions for Safe Use (X):

1. Flameproof joints are not intended for repair.
2. Non-standard paint options may cause risk of electrostatic discharge. Avoid installations that cause electrostatic build-up on painted surfaces and only clean the painted surfaces with a damp cloth. If paint is ordered through a special option code, contact the manufacturer for more information.
3. See instructions for relation between process temperature, ambient temperature, and temperature class/ maximum surface temperature "T".

Process temperature range at sensor connection (°C) ⁽¹⁾	Ambient temperature range (°C)	Temperature class
-60 °C to +70 °C	-60 °C to +70 °C	T6
-60 °C to +80 °C	-60 °C to +80 °C	T5...T1
-60 °C to +80 °C	-60 °C to +80 °C	T130 °C

(1) Sensor Connection is where the sensor threads into the transmitter or junction box housing.

5.6.2 I2 INMETRO Intrinsic Safety

Certificate UL-BR 15.0030X

Standards ABNT NBR IEC 60079-0:2013, ABNT NBR IEC 60079-11:2013

Markings Ex ia IIC T4 Ga (-60 °C ≤ T_a ≤ +60 °C)
See [Table 5-4](#) at the end of the Product Certifications section for Entity Parameters

Special Conditions for Safe Use (X):

1. When fitted with the transient terminal options, the equipment is not capable of withstanding the 500 V electrical strength test as defined in ABNT NBR IEC60079-11. This must be taken into account during installation.
2. The enclosure may be made from aluminum alloy with a protective polyurethane paint finish; however, care should be taken to protect it from impact and abrasion when located in areas that require EPL Ga (Zone 0).

5.7 China

5.7.1 E3 China Flameproof

Certificate GYJ21.1277X

Standards GB/T 3836.1-2021, GB/T 3836.2-2021, GB/T 3836.31-2021

Markings Ex db IIC T6…T1 Gb, Ex tb III C T130 °C Db

- 产品安全使用特殊条件

证书编号后缀“X”表明产品具有安全使用特殊条件：

1. 涉及隔爆接合面的维修须联系产品制造商。
2. 产品铭牌材质为非金属，使用时须防止产生静电火花，只能用湿布清理。
3. XA 选项时必须配套管以保证实现粉尘防护型式。
4. 产品温度组别和使用环境温度范围之间的关系为：

过程温度	环境温度	温度组别
$-60\text{ °C} \leq T_a \leq +70\text{ °C}$	$-60\text{ °C} \leq T_a \leq +70\text{ °C}$	T6
$-60\text{ °C} \leq T_a \leq +80\text{ °C}$	$-60\text{ °C} \leq T_a \leq +80\text{ °C}$	T5…T1
$-60\text{ °C} \leq T_a \leq +80\text{ °C}$	$-60\text{ °C} \leq T_a \leq +80\text{ °C}$	T130 °C

- 产品使用注意事项

1. 产品外壳设有接地端子，用户在使用时应可靠接地。
2. 安装现场应不存在对产品外壳有腐蚀作用的有害气体。
3. 现场安装时，电缆引入口须选用国家指定的防爆检验机构按检验认可、具有 Ex db IIC Gb 、 Ex tb IIIC Db 防爆等级的电缆引入装置或堵封件，冗余电缆引入口须用堵封件有效密封。
4. 用于爆炸性气体环境中，现场安装、使用和维护必须严格遵守“断电后开盖！”的警告语。用于爆炸性粉尘环境中，现场安装、

使用和维护必须严格遵守“爆炸性粉尘场所严禁开盖！”的警告语。

5. 用于爆炸性粉尘环境中，产品外壳表面需保持清洁，以防粉尘堆积，但严禁用压缩空气吹扫。
6. 用户不得自行更换该产品的零部件，应会同产品制造商共同解决运行中出现的故障，以杜绝损坏现象的发生。
7. 产品的安装、使用和维护应同时遵守产品使用说明书、GB/T 3836.13-2021“爆炸性环境 第 13 部分：设备的修理、检修、修复和改造”、GB/T 3836.15-2017“爆炸性环境 第 15 部分：电气装置的设计、选型和安装”、GB/T 3836.16-2017“爆炸性环境 第 16 部分：电气装置的检查与维护”、GB50257-2014“电气装置安装工程爆炸和火灾危险环境电力装置施工及验收规范”和 GB15577-2018“粉尘防爆安全规程”的有关规定。

5.7.2 I3 China Intrinsic Safety

Certificate	GYJ21.1278X
Standards	GB/T3836.1-2021, GB/T 3836.4-2021
Markings	Ex ia IIC T4 Ga

- 产品安全使用特殊条件
产品防爆合格证号后缀“X”代表产品安全使用有特殊条件：
 1. 产品外壳含有轻金属，在 0 区使用需防止由于冲击或摩擦产生的点燃危险。
 2. 产品选用瞬态保护端子板（选项代码为 T1）时，此设备不能承受 500V 交流有效值试验电压的介电强度试验。
 3. 产品温度组别与使用环境温度范围的关系：

输出	温度组别	环境温度
Fieldbus	T4	$-60\text{ °C} \leq T_a \leq +60\text{ °C}$

- 产品使用注意事项

本安电气参数：

Table 5-1: Power loop terminals (+ and -)

输出	最高输入电压 U_i (V)	最大输入电流 I_i (mA)	最大输入功率 P_i (W)	最大内部等效参数	
				C_i (nF)	L_i (μ H)
Fieldbus	30	300	1.3	2.1	0
FISCO	17.5	380	5.32	2.1	0

Table 5-2: Sensor terminals (1 to 5)

输出	最高输出 电压 U_o (V)	最大输出 电流 I_o (mA)	最大输出 功率 P_o (W)	最大内部等效参数	
				C_i (nF)	L_i (μ H)
Fieldbus	13.9	23	0.079	7.7	0

Table 5-3: Load connected to sensor terminals (1 to 5)

输出	组别	最大外部等效电路		
		C_o (μ F)	L_o (mH)	L/R (μ H/ Ω)
Fieldbus	IIC	0.73	30.2	187
	IIB	4.8	110.9	710
	IIA	17.69	231.2	1300

4. 该产品必须与已通过防爆认证的关联设备配套共同组成本安防爆系统方可使用于爆炸性气体环境。其系统接线必须同时遵守本产品和所配关联设备的使用说明书要求，接线端子不得接错。
5. 用户不得自行更换该产品的零部件，应会同产品制造商共同解决运行中出现的故障，以杜绝损坏现象的发生。
6. 产品的安装、使用和维护应同时遵守产品使用说明书、GB/T3836.13-2021“爆炸性环境 第 13 部分：设备的修理、检修、修复和改造”、GB/T 3836.15-2017“爆炸性环境 第 15 部分：电气装置的设计、选型和安装”、GB/T 3836.16-2022“爆炸性环境 第 16 部分：电气装置的检查与维护”、GB50257-2014“电气装置安装工程爆炸和火灾危险环境电力装置施工及验收规范”的有关规定。

5.7.3 N3 China Type n

Certificate	GYJ20.1086X
Standards	GB/T 3836.1-2021, GB/T 3836.3-2021
Markings	Ex ec IIC T5 Gc

Output	T code	Ambient temperature
Fieldbus	T5	$-40\text{ }^{\circ}\text{C} \leq T_a \leq +75\text{ }^{\circ}\text{C}$

- 产品安全使用特殊条件
产品防爆合格证后缀“X”代表产品安全使用有特殊条件：
此设备不能承受 500V 交流有效值介电强度试验，安装时需考虑在内。
- 产品使用注意事项

Fieldbus: $-40\text{ °C} \leq T_a \leq +75\text{ °C}$

1. 输入参数:

$U_i = 32\text{ Vdc}$

$C_i = 2.1\text{ nF}$ (Loop terminals)

$C_i = 7.7\text{ nF}$ (Sensor terminals)

$L_i = 0$

2. 产品外壳设有接地端子，用户在安装使用时应可靠接地。
3. 产品外壳防护等级（IP 代码）为 IP54。
4. 现场安装时，电缆引入口须选用国家指定的防爆检验机构按检验认可、符合 GB/T 3836.1-2021、GB/T 3836.3-2021 要求且具有 Ex ec IIC 防爆等级、达到 IP54 外壳防护等级的电缆引入装置或堵封件，冗余电缆引入口须用堵封件有效密封。
5. 用户不得自行更换该产品的零部件，应会同产品制造商共同解决运行中出现的故障，以杜绝损坏现象的发生。
6. 产品的安装、使用和维护应同时遵守产品使用说明书、GB/T 3836.13-2021“爆炸性环境 第 13 部分：设备的修理、检修、修复和改造”、GB/T 3836.15-2017“爆炸性环境 第 15 部分：电气装置的设计、选型和安装”、GB/T 3836.16-2022“爆炸性环境 第 16 部分：电气装置的检查与维护”和 GB 50257-2014“电气装置安装工程爆炸和火灾危险环境电力装置施工及验收规范”的有关规定。

5.8 EAC - Belarus, Kazakhstan, Russia

5.8.1 EM Technical Regulation Customs Union (EAC) Flameproof

Certificate EAЭC KZ 7500525.01.01.00686

Standards GOST 31610.0-2019, GOST IEC 60079-1-2013

Markings 1Ex db IIC T6...T1 Gb X, T6($-60\text{ °C} \leq T_a \leq +70\text{ °C}$), T5...T1($-60\text{ °C} \leq T_a \leq +80\text{ °C}$)

Special Condition for Safe Use (X):

Refer to certificate for details regarding process and ambient temperature limits as well as Special Conditions for Safe Use.

5.8.2 IM Technical Regulation Customs Union (EAC) Intrinsic Safety

Certificate EAЭC KZ 7500525.01.01.00686

Standards GOST 31610.0-2019, GOST IEC 60079-11-2014

Markings 0Ex ia IIC T4 Ga X, T4($-60\text{ °C} \leq T_a \leq +60\text{ °C}$)
See [Table 5-4](#) for entity parameters.

Special Condition for Safe Use (X):

Refer to certificate for details regarding process and ambient temperature limits as well as Special Conditions for Safe Use.

5.8.3 KM Technical Regulation Customs Union (EAC) Flameproof, Intrinsic Safety, and Dust

Certificate EAЭC KZ 7500525.01.01.00686

Standards GOST 31610.0-2019, GOST IEC 60079-1-2013, GOST IEC 60079-11-2014, GOST IEC 60079-31-2013

Markings Ex tb IIIC T130 °C Db X (-60 °C ≤ T_a ≤ +80 °C), IP66, 68 in addition to markings listed for EM and IM above.

Special Condition for Safe Use (X):

Refer to certificate for details regarding process and ambient temperature limits as well as Special Conditions for Safe Use.

See [EM Technical Regulation Customs Union \(EAC\) Flameproof](#) for flameproof specific conditions of use and see [IM Technical Regulation Customs Union \(EAC\) Intrinsic Safety](#) for intrinsic safety specific conditions of use.

5.9 Japan

5.9.1 E4 Japan Flameproof

Certificate CML 21JPN1842X

Markings Ex db IIC T6...T1 Gb; T6 (-60 °C ≤ T_a ≤ +70 °C); T5...T1 (-60 °C ≤ T_a ≤ +80 °C)

Special Conditions for Safe Use:

1. Flameproof joints are not intended for repair.
2. Non-standard paint options may cause risk from electrostatic discharge. Avoid installations that could cause electrostatic build-up on painted surfaces, and only clean the painted surfaces with a damp cloth. If paint is ordered through a special option code, contact the manufacturer for more information.
3. See instructions for relation between process temperature, ambient temperature and temperature class.

Process temperature range at sensor connection (°C) ⁽¹⁾	Ambient temperature range (°C)	Temperature class
-60 °C to +70 °C	-60 °C to +70 °C	T6
-60 °C to +80 °C	-60 °C to +80 °C	T5...T1

(1) *Sensor Connection is where the sensor threads into the transmitter or junction box housing.*

5.10 Combinations

- K1** Combination of E1, I1, N1, and ND
- K2** Combination of E2 and I2
- K5** Combination of E5 and I5
- K7** Combination of E7, I7, and N7
- KB** Combination of K5, I6, and K6
- KM** Combination of EM and IM
- KP** Combination of EP and IP
- KA** Combination of E1, I1 and K6
- K3** Combination of E3, I3 and N3

5.11 Tables

Table 5-4: Entity parameters

Parameters	Fieldbus/PROFIBUS	FISCO
Voltage U_i (V)	30	17.5
Current I_i (mA)	300	380
Power P_i (W)	1.3	5.32
Capacitance C_i (nF)	2.1	2.1
Inductance L_i (mH)	0	0

5.12 Additional certifications

SBS American Bureau of Shipping (ABS) type approval

Certificate 16-HS1488352-PDA

Intended use Measurement of temperature for marine and offshore applications

SBV Bureau Veritas (BV) type approval

Certificate 23154

Requirements Bureau Veritas rules for the classification of steel ships

Application Class notations: AUT-UMS, AUT-CCS, AUT-PORT and AUT-IMS; temperature transmitter type 3144P cannot be installed on diesel engines

SDN Det Norske Veritas (DNV) type approval

Certificate TAA00001JK

Intended use Det Norske Veritas' rules for classification of ships, high speed, and light craft and Det Norske Veritas' offshore standards

Application **Table 5-5: Location classes**

Temperature	D
Humidity	B
Vibration	A
EMC	A
Enclosure	D

5.14 Declaration of conformity



EU Declaration of Conformity

No: RMD 1045 Rev. P



We,

Rosemount, Inc.
6021 Innovation Boulevard
Shakopee, MN 55379-4676
USA

declare under our sole responsibility that the product,

Rosemount™ 3144P Temperature Transmitter

manufactured by,

Rosemount, Inc.
6021 Innovation Boulevard
Shakopee, MN 55379-4676
USA

to which this declaration relates, is in conformity with the provisions of the European Union Directives, including the latest amendments, as shown in the attached schedule.

Assumption of conformity is based on the application of the harmonized standards and, when applicable or required, a European Union notified body certification, as shown in the attached schedule.



(signature)

Vice President of Global Quality

(function)



Mark Lee

(name)

October 22, 2021

(date of issue)

Page 1 of 3

 **EMERSON** **EU Declaration of Conformity** 

No: RMD 1045 Rev. P

EMC Directive (2014/30/EU)

Harmonized Standards: EN61326-1:2013, EN61326-2-3: 2013

ATEX Directive (2014/34/EU)

Rosemount 3144P Temperature Transmitter (4-20mA/HART Output)

BAS01ATEX1431X – Intrinsic Safety Certificate
Equipment Group II, Category 1 G (Ex ia IIC T5/T6 Ga)
Harmonized Standards:
EN IEC 60079-0:2018, EN60079-11:2012



BAS01ATEX3432X – Type n Certificate
Equipment Group II, Category 3 G (Ex nA IIC T5/T6 Gc)
Harmonized Standards:
EN IEC 60079-0:2018, EN60079-15:2010

Rosemount 3144P Temperature Transmitter (Fieldbus Output)

Baseefa03ATEX0708X – Intrinsic Safety Certificate
Equipment Group II, Category 1 G (Ex ia IIC T4 Ga)
Harmonized Standards:
EN IEC 60079-0:2018, EN60079-11:2012

Baseefa03ATEX0709 – Type n Certificate
Equipment Group II, Category 3 G (Ex nA IIC T5 Gc)
Harmonized Standards:
EN IEC 60079-0:2018, EN60079-15:2010

Page 2 of 3

 **EU Declaration of Conformity** 
No: RMD 1045 Rev. P

Rosemount 3144P Temperature Transmitter (all Output Protocols)

DEKRA 19ATEX0076 X – Dust Certificate
Equipment Group II, Category 2 D (Ex tb IIIC T130°C Db)
Harmonized Standards:
EN IEC 60079-0:2018, EN 60079-31:2014

DEKRA 19ATEX0076 X – Flameproof Certificate
Equipment Group II, Category 2 G (Ex db IIC T6...T1 Gb)
Harmonized Standards:
EN IEC 60079-0:2018, EN 60079-1:2014

ATEX Notified Bodies

SGS FIMKO OY [Notified Body Number: 0598]
Takomotie 8
00380 HELSINKI
Finland

Dekra Certification B.V. [Notified Body Number: 0344]
Utrechtseweg 310
Postbus 5185
6802 ED Arnhem
Netherlands

ATEX Notified Body for Quality Assurance

SGS FIMKO OY [Notified Body Number: 0598]
Takomotie 8
00380 HELSINKI
Finland

Page 3 of 3

5.15 China RoHS

有害物质成分表
00079-2000, Rev AC

罗斯蒙特产品型号 **3144P**
1/5/2024

含有 China RoHS 管控物质超过最大浓度限值的部件型号列表 3144P
List of 3144P Parts with China RoHS Concentration above MCVs

部件名称 Part Name	有害物质 / Hazardous Substances					
	铅 Lead (Pb)	汞 Mercury (Hg)	镉 Cadmium (Cd)	六价铬 Hexavalent Chromium (Cr +6)	多溴联苯 Polybrominated biphenyls (PBB)	多溴联苯醚 Polybrominated diphenyl ethers (PBDE)
电子组件 Electronics Assembly	X	○	○	○	○	○
壳体组件 Housing Assembly	○	○	○	X	○	○

本表格系依据 SJ/T11364 的规定而制作。
This table is proposed in accordance with the provision of SJ/T11364.

○ 意为该部件的所有均质材料中该有害物质的含量均低于 GB/T 26572 所规定的限量要求。
○ Indicate that said hazardous substance in all of the homogeneous materials for this part is below the limit requirement of GB/T 26572.

X: 意为在该部件所使用的的所有均质材料里，至少有一类均质材料中该有害物质的含量高于 GB/T 26572 所规定的限量要求。

X: Indicate that said hazardous substance contained in at least one of the homogeneous materials used for this part is above the limit requirement of GB/T 26572.

部件名称 Part Name	组装各件说明 Spare Parts Descriptions for Assemblies
电子组件 Electronics Assembly	电子线路板组件 Electronic Board Assemblies 端子块组件 Terminal Block Assemblies 液晶显示屏或本地操作界面 LCD or LOI Display
壳体组件 Housing Assembly	电子外壳 Electrical Housing

5.16 Y3 ATEX/IECEx RFID tag approvals

Certificate IECEx EPS 15.0042X, EPS 15 ATEX 1 1011 X

Markings II 2G Ex ia IIC T6/T4 Gb, II 2D Ex ia IIC T80/T130C Db

Conditions of certification

Maximum operating temperature: -58 °F (-50 °C) to +158 °F (+70 °C)

The RFID tags shall never be exposed to high electromagnetic field strengths according to IEC 60079-14.

Electrostatic charges shall be avoided. The tags shall never be used next to strong charge generating processes.

⚠ WARNING

Additional warnings

The plastic enclosure may present a potential electrostatic ignition hazard.

RFID tag has limitations in ambient temperature and zone installation areas (Zones 1 & 21) as compared to the gauge.



Quick Start Guide
00825-0100-4834, Rev. FD
November 2024

For more information: [Emerson.com/global](https://www.emerson.com/global)

©2024 Emerson. All rights reserved.

Emerson Terms and Conditions of Sale are available upon request. The Emerson logo is a trademark and service mark of Emerson Electric Co. Rosemount is a mark of one of the Emerson family of companies. All other marks are the property of their respective owners.

ROSEMOUNT™

