

*Implant Innovation*

When INNOVATION meets Dental Implant..



**INNO SUBMERGED IMPLANT**

# INNO-SUBMERGED IMPLANT

## Submerged Implant System Flow

Fixture	Abutment	Impression
<p>Hex 2.5</p> <p>Length 7 / 8 / 10 12 / 14 16 / 18 mm</p> <p>Diameter Ø3.5 / 4.0 / 4.5 / 5.0 / 6.0</p>	<p><b>Prosthetic Procedure I</b></p> <p>033p 033p 033p 033p 033p</p> <p>Hybrid S Ø4.0 Hybrid S Ø5.0/6.0 Hybrid L Ø4.0 Hybrid L Ø5.0/6.0 Hex Hybrid Ti-Block</p> <p>034p 034p 035p 035p 035p 036p 036p</p> <p>Cemented Angulated Milling Easy Temporary Temporary Meta G UCLA Plastic UCLA</p>	<p><b>Fixture Level Impression</b></p> <p>033p Scanbody</p> <p>036p 037p 037p</p> <p>Replica Pick-up Impression Coping Transfer Post</p>
	<p><b>Prosthetic Procedure II</b></p> <p>039p 039p</p> <p>Multi S Multi A</p>	<p>039p 040p 040p 040p 040p 041p 041p 041p 041p 042p</p> <p>Multi Protection Cap Multi Scanbody Multi Hybrid Ti-Base Multi Impression Coping Multi Transfer Post Multi Lab Analog Multi Meta G ULCA Cylinder Multi Plastic UCLA Cylinder Multi Titanium Cylinder Polishing Protector</p>
	<p><b>Prosthetic Procedure III</b></p> <p>044p</p> <p>Lock</p>	<p>044p 044p 044p 044p 045p 045p 045p</p> <p>Lock Protection Cap Look Scanbody Look Hybrid Ti-Base Lock Pick-up Impression Coping Lock Lab Analog Lock Meta G UCLA Cylinder Lock Titanium Cylinder</p>
	<p><b>Prosthetic Procedure IV</b></p> <p>047p</p> <p>Absolute</p>	<p>047p 047p 047p 047p</p> <p>Absolute Protection Cap Absolute Impression Cap Absolute Lab Analog Absolute Plastic Coping</p>
	<p><b>Prosthetic Procedure V</b></p> <p>048p</p> <p>Straight</p>	<p>Direct Impression</p>
	<p><b>Prosthetic Procedure VI</b></p> <p>050p 050p</p> <p>Sonator S Sonator A</p>	<p>051p 051p</p> <p>Sonator Impression Coping Sonator Analog</p>
	<p><b>Prosthetic Procedure VII</b></p> <p>054p</p> <p>Ball</p>	<p>054p</p> <p>Ball Analog</p>

# Submerged Implant

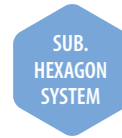

Submerged Fixture  
Surface Treatment : **SLA-SH®**

- > Interchangeable with Hexagonal Morse Tapered Fixture
- > Internal Hex Connection (Taper 11°/ Hex 2.5)

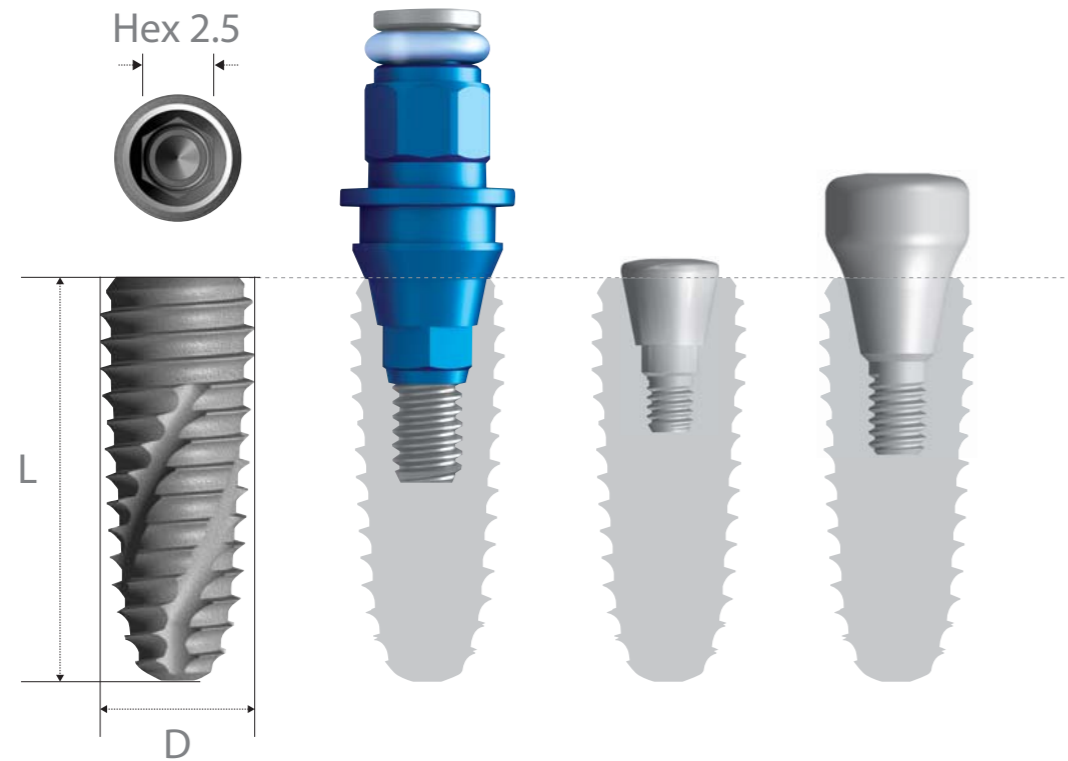

## INNO Fixture Code

**S** Type Submerged  
**T** body Taper  
**40** Diameter **Ø4.0**  
**10** Length **10mm**  
**S** Surface Treatment **SLA**  
**M** Mount No-Mount

\* Ex.)  
SLA No-Mount **ST4010SM**

**S** Type Submerged  
**T** body Taper  
**40** Diameter **Ø4.0**  
**10** Length **10mm**  
**S** Surface Treatment **SLA**  
Mount Pre-Mount

\* Ex.)  
SLA Pre-Mount **ST4010S**

No-Mount > Packing Unit : 1 Fixture + 1 Cover Screw

Diameter **Ø3.5**  
Length

7	-
8	ST3508SM
10	ST3510SM
12	ST3512SM
14	ST3514SM

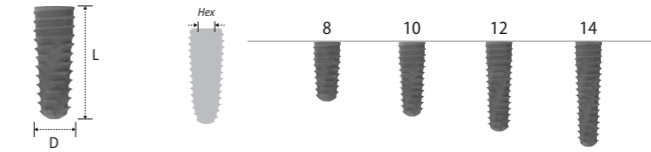

Diameter **Ø4.0**  
Length

7	ST4007SM
8	ST4008SM
10	ST4010SM
12	ST4012SM
14	ST4014SM
16	ST4016SM
18	ST4018SM

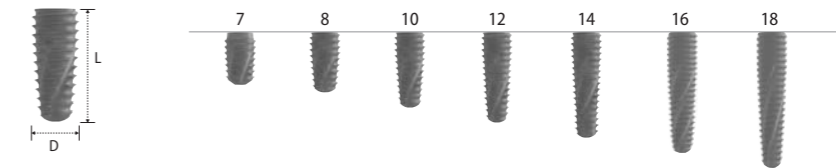

Diameter **Ø4.5**  
Length

7	ST4507SM
8	ST4508SM
10	ST4510SM
12	ST4512SM
14	ST4514SM
16	ST4516SM
18	ST4518SM

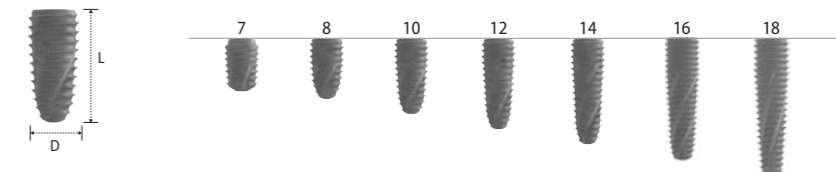

Diameter **Ø5.0**  
Length

7	ST5007SM
8	ST5008SM
10	ST5010SM
12	ST5012SM
14	ST5014SM

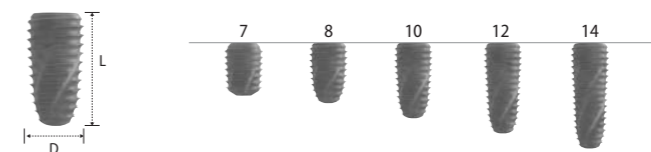

Diameter **Ø6.0**  
Length

7	ST6007SM
8	ST6008SM
10	ST6010SM
12	ST6012SM
14	-

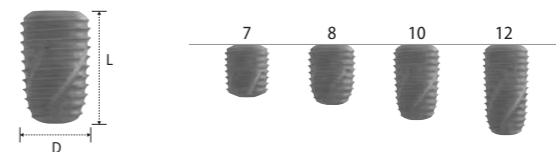

Pre-Mount > Packing Unit : 1 Fixture + 1 Cover Screw + 1 Mount

Diameter	Ø3.5
Length	
7	-
8	ST3508S
10	ST3510S
12	ST3512S
14	ST3514S

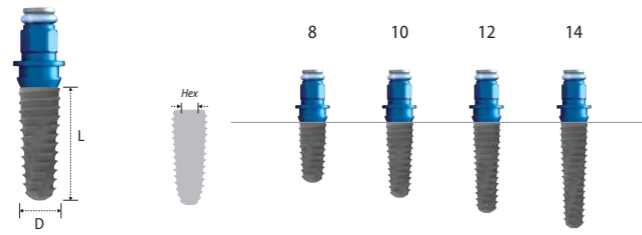

Diameter	Ø4.0
Length	
7	ST4007S
8	ST4008S
10	ST4010S
12	ST4012S
14	ST4014S
16	ST4016S
18	ST4018S

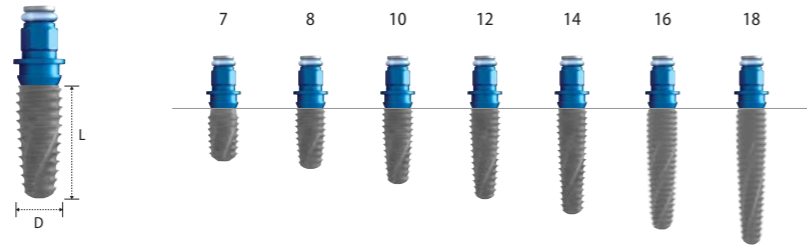

Diameter	Ø4.5
Length	
7	ST4507S
8	ST4508S
10	ST4510S
12	ST4512S
14	ST4514S
16	ST4516S
18	ST4518S

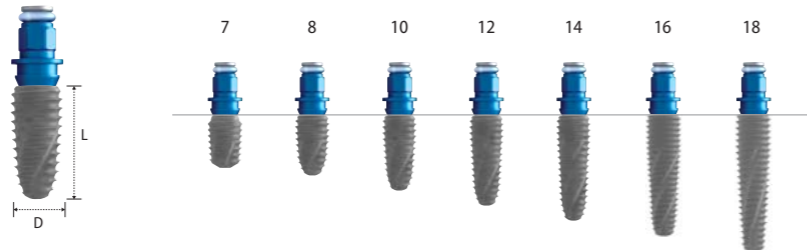

Diameter	Ø5.0
Length	
7	ST5007S
8	ST5008S
10	ST5010S
12	ST5012S
14	ST5014S

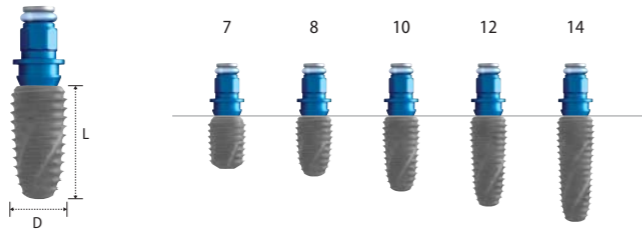

Diameter	Ø6.0
Length	
7	ST6007S
8	ST6008S
10	ST6010S
12	ST6012S
14	-

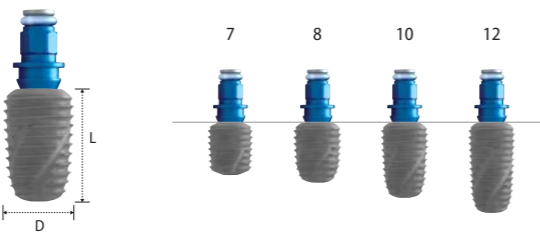

Fixture Mount



Length	5.4
	2SMHR001

- > Packing Unit : 1 Mount + 1 Mount Screw
- > Tightened with 1.2 Hex Driver
- > Tightening Torque Force : 5~10 N.cm

Cover Screw



Length	3	4.2	5.2
	2SCS000	*2SCS001	*2SCS002

\*Extra Product

- > Packing Unit : 1 Cover Screw
- > To Seal the Conical Interface of Fixture
- > Longer Cover Screw for Deeply Inserted Fixture
- > Tightened with 1.2 Hex Driver
- > Tightening Torque Force : 5~10 N.cm

Healing Abutment

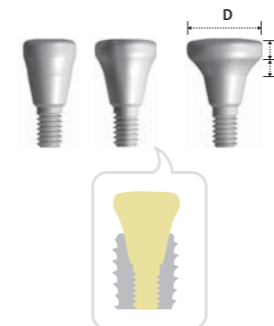

Diameter	Ø4.5		Ø5.5		Ø6.5	
Length / Cuff	1	2	1	2	1	2
1	2HS4511		2HS5511		2HS6511	
2		2HS4522		2HS5522		2HS6522
3		2HS4532		2HS5532		2HS6532
4		2HS4542		2HS5542		2HS6542
5		2HS4552		2HS5552		2HS6552
7		2HS4572		2HS5572		2HS6572

Diameter	Ø7.5	Ø8.5	Ø9.5
Length / Cuff	2	2	2
3	2HS7532	2HS8532	2HS9532

- > Packing Unit : 1 Abutment
- > For Remodeling Gingival Contour during Soft Tissue Healing
- > Select according to Gingival Height and Abutment Type
- > Tightened with 1.2 Hex Driver
- > Tightening Torque Force : 5~10 N.cm

# Prosthetic Procedure I

## Components Selection Guide for Ti-Base & Block, Cemented and UCLA Abutment

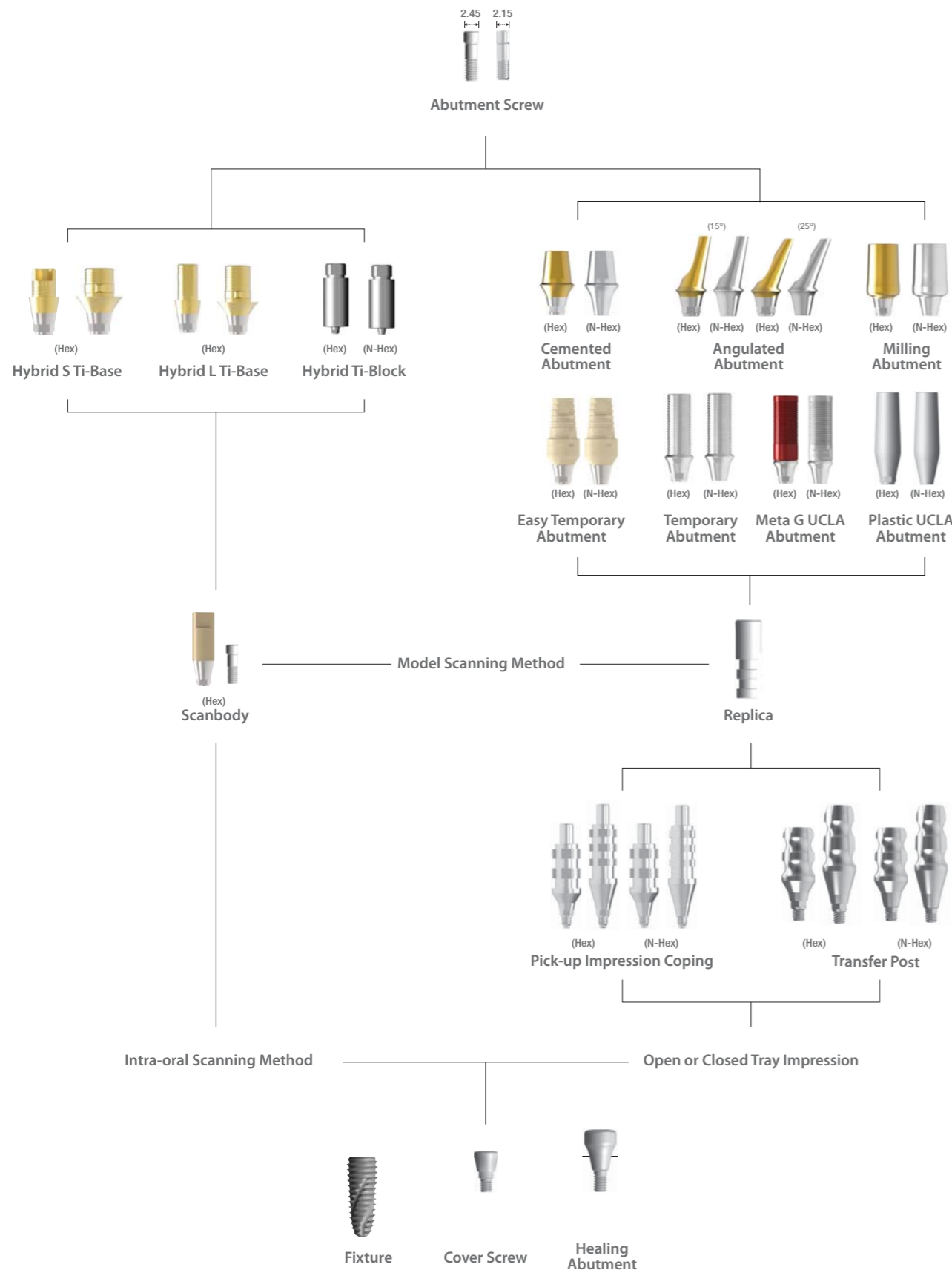

### Hybrid S Ti-Base

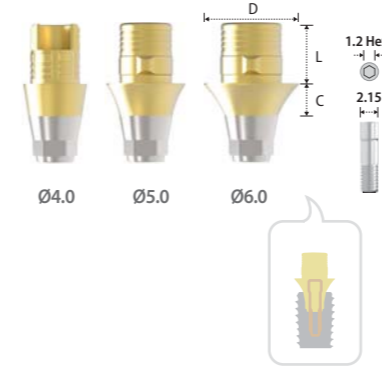

Type	Hex		
Diameter	Ø4.0	Ø5.0	Ø6.0
Length	3.75	3.75	3.75
0.8	2SLH404	2SLH504	2SLH604
2	2SLH424	2SLH524	2SLH624
3	2SLH434	2SLH534	2SLH634

- > Packing Unit : 1 Ti-Base + 1 Abutment Screw
- > For Screw-Cement or Screw Retained Abutment
- > Titanium Base for Strength of CAD/CAM
- > Gold Color for More Translucent Restoration
- > Lingual Surface Hole for More Esthetic Restoration (Ø4.0)
- > Right Angled (Ø4.0) and Humped Design (Ø5.0, Ø6.0) for Anti-Rotation of Prosthesis
- > Library available for EXOCAD®, 3Shape®, Dental Wings® and Others
- > Connected with Abutment Screw (2SSHR200)
- > Tightened with 1.2 Hex Driver and Torque Wrench
- > Tightening Torque Force : 30 N.cm
- > Use Scanbody for 3D Work
- > Fixture Level Impression

### Hybrid L Ti-Base

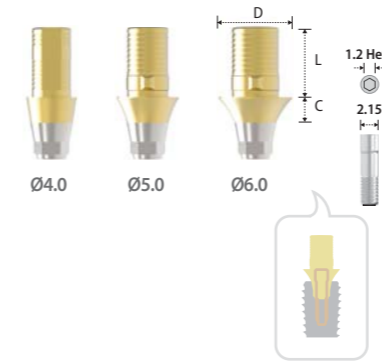

Type	Hex		
Diameter	Ø4.0	Ø5.0	Ø6.0
Length	5.5	5.5	5.5
1	2SLH415	2SLH515	2SLH615
2	2SLH425	2SLH525	2SLH625
3	2SLH435	2SLH535	2SLH635

- > Packing Unit : 1 Ti-Base + 1 Abutment Screw
- > For Screw-Cement or Screw Retained Abutment
- > Titanium Base for Strength of CAD/CAM
- > Gold Color for More Translucent Restoration
- > Cutting Surface (Ø4.0) and Humped Design (Ø5.0, Ø6.0) for Anti-Rotation of Prosthesis
- > Library available for EXOCAD®, 3Shape®, Dental Wings® and Others
- > Connected with Abutment Screw (2SSHR200)
- > Tightened with 1.2 Hex Driver and Torque Wrench
- > Tightening Torque Force : 30 N.cm
- > Use Scanbody for 3D Work
- > Fixture Level Impression

### Hybrid Ti-Block

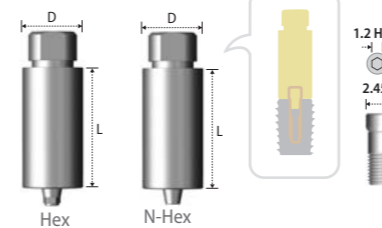

Type	Hex			N-Hex		
Diameter	10	12	14	10	12	14
Length	20	20	20	20	20	20
	CSHH10S	CSHH12S	CSHH14S	CSHN10S	CSHN12S	CSHN14S

- > Packing Unit : 1 Ti-Block + 2 Abutment Screws
- > For Screw-Cement or Screw Retained Abutment
- > Block Abutment for CAD/CAM Customized Abutment
- > Library available for EXOCAD®, 3Shape®, Dental Wings® and Others
- > Connected with Abutment Screw (2SSHR100)
- > Tightened with 1.2 Hex Driver and Torque Wrench
- > Tightening Torque Force : 30 N.cm
- > Use Scanbody for 3D Work
- > Fixture Level Impression

### Scanbody

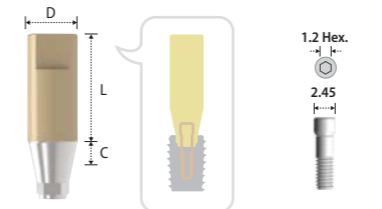

Diameter	Ø4.3
Length	8
2	2SSB4329

- > Packing Unit : 1 Scanbody + 1 Abutment Screw
- > For both, Model Scanner and Intra Oral Scanner
- > For Hybrid S & L Ti-Base and Hybrid A Ti-Block
- > Titanium Core for More Strength and Precision
- > No Need to Spray
- > Connected with Abutment Screw (2SSHR100)
- > Tightened with 1.2 Hex Driver and Torque Wrench
- > Tightening Torque Force : 15~20 N.cm

## Cemented Abutment

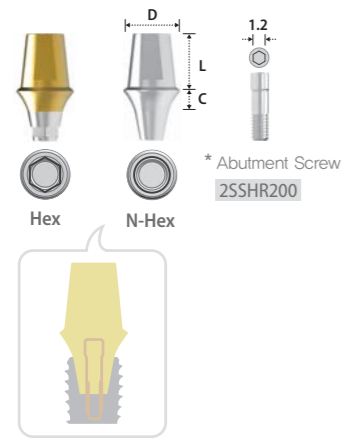

Type	Hex								
Diameter	Ø4.5			Ø5.5			Ø6.5		
Length / Cuff	4	5.5	7	4	5.5	7	4	5.5	7
1	2SCH4514	2SCH4515	2SCH4517	2SCH5514	2SCH5515	2SCH5517	2SCH6514	2SCH6515	2SCH6517
2	2SCH4524	2SCH4525	2SCH4527	2SCH5524	2SCH5525	2SCH5527	2SCH6524	2SCH6525	2SCH6527
3	2SCH4534	2SCH4535	2SCH4537	2SCH5534	2SCH5535	2SCH5537	2SCH6534	2SCH6535	2SCH6537
4	2SCH4544	2SCH4545	2SCH4547	2SCH5544	2SCH5545	2SCH5547	2SCH6544	2SCH6545	2SCH6547
5	2SCH4554	2SCH4555	2SCH4557	2SCH5554	2SCH5555	2SCH5557	2SCH6554	2SCH6555	2SCH6557

Type	N-Hex								
Diameter	Ø4.5			Ø5.5			Ø6.5		
Length / Cuff	4	5.5	7	4	5.5	7	4	5.5	7
1	2SCN4514	2SCN4515	2SCN4517	2SCN5514	2SCN5515	2SCN5517	2SCN6514	2SCN6515	2SCN6517
2	2SCN4524	2SCN4525	2SCN4527	2SCN5524	2SCN5525	2SCN5527	2SCN6524	2SCN6525	2SCN6527
3	2SCN4534	2SCN4535	2SCN4537	2SCN5534	2SCN5535	2SCN5537	2SCN6534	2SCN6535	2SCN6537
4	2SCN4544	2SCN4545	2SCN4547	2SCN5544	2SCN5545	2SCN5547	2SCN6544	2SCN6545	2SCN6547
5	2SCN4554	2SCN4555	2SCN4557	2SCN5554	2SCN5555	2SCN5557	2SCN6554	2SCN6555	2SCN6557

- > Packing Unit : 1 Abutment + 1 Abutment Screw
- > For Screw-Cement or Cement Retained Prosthesis
- > Cutting Surface for Anti-rotation of Prosthesis
- > Gold Color for More Translucent Restoration (Hex) and Classification with N-Hex
- > Library available for EXOCAD®, 3Shape®, Dental Wings® and Others
- > Connected with Abutment Screw (2SSHR200)
- > Tightened with 1.2 Hex Driver and Torque Wrench
- > Tightening Torque Force : 30 N.cm
- > Use Scanbody for 3D Work
- > Fixture Level Impression

## Angulated Abutment

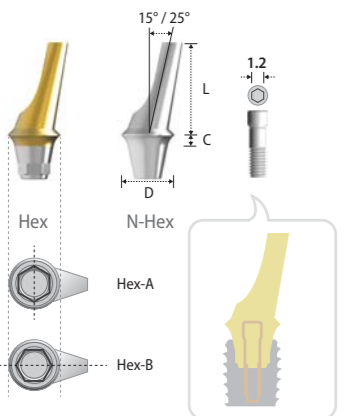

Type	Hex-A				Hex-B			
Diameter(Angle)	Ø4.5(15°)	Ø4.5(25°)	Ø5.5(15°)	Ø5.5(25°)	Ø4.5(15°)	Ø4.5(25°)	Ø5.5(15°)	Ø5.5(25°)
Length / Cuff	8	8	8	8	8	8	8	8
1	2SAH45151	2SAH45251	2SAH55151	2SAH55251	2SAH45151B	2SAH45251B	2SAH55151B	2SAH55251B
2	2SAH45152	2SAH45252	2SAH55152	2SAH55252	2SAH45152B	2SAH45252B	2SAH55152B	2SAH55252B
3	2SAH45153	2SAH45253	2SAH55153	2SAH55253	2SAH45153B	2SAH45253B	2SAH55153B	2SAH55253B
4	2SAH45154	2SAH45254	2SAH55154	2SAH55254	2SAH45154B	2SAH45254B	2SAH55154B	2SAH55254B

Type	N-Hex			
Diameter(Angle)	Ø4.5(15°)	Ø4.5(25°)	Ø5.5(15°)	Ø5.5(25°)
Length / Cuff	8	8	8	8
1	2SAN45151	2SAN45251	2SAN55151	2SAN55251
2	2SAN45152	2SAN45252	2SAN55152	2SAN55252
3	2SAN45153	2SAN45253	2SAN55153	2SAN55253
4	2SAN45154	2SAN45254	2SAN55154	2SAN55254

- > Packing Unit : 1 Abutment + 1 Abutment Screw
- > For Screw-Cement or Cement Retained Prosthesis
- > Solution for Anterior Esthetic Zone
- > Connected with Abutment Screw (2SSHR100)
- > Gold Color for More Translucent Restoration (Hex) and Classification with N-Hex
- > Select Hex-A or Hex-B according to Case
- > Tightened with 1.2 Hex Driver and Torque Wrench
- > Tightening Torque Force : 30 N.cm
- > Fixture Level Impression

## Milling Abutment

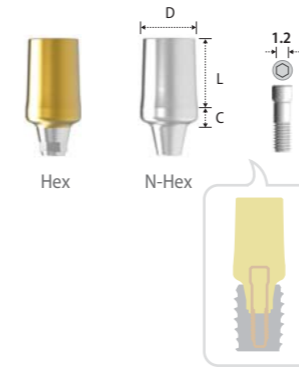

Type	Hex			N-Hex		
Diameter	Ø4.5	Ø5.5	Ø6.5	Ø4.5	Ø5.5	Ø6.5
Length / Cuff	7	7	7	7	7	7
2	2SMH4527	2SMH5527	2SMH6527	2SMN4527	2SMN5527	2SMN6527
4	2SMH4547	2SMH5547	2SMH6547	2SMN4547	2SMN5547	2SMN6547

- > Packing Unit : 1 Abutment + 1 Abutment Screw
- > For Screw-Cement or Cement Retained Prosthesis
- > Block Abutment for Customized Contouring
- > Gold Color for More Translucent Restoration (Hex) and Classification with N-Hex
- > Connected with Abutment Screw (2SSHR100)
- > Tightened with 1.2 Hex Driver and Torque Wrench
- > Tightening Torque Force : 30 N.cm
- > Fixture Level Impression

## Easy Temporary Abutment

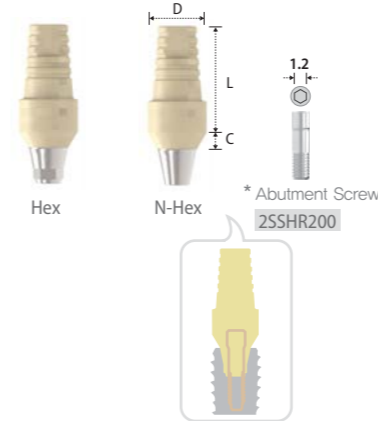

Type	Hex		N-Hex	
Diameter	Ø4.5	Ø5.5	Ø4.5	Ø5.5
Length / Cuff	10	10	10	10
2	2STHA45C	2STHA55C	2STNA45C	2STNA55C

- > Packing Unit : 1 Abutment + 1 Abutment Screw
- > For Screw Retained Prosthesis
- > For Simpler and Speedier Chair-side Process
- > Vanearerable Polymer Material
- > Temporary Restoration for Anterior Esthetic Zone
- > Titanium Core for Strength
- > Connected with Abutment Screw (2SSHR200)
- > Tightened with 1.2 Hex Driver and Torque Wrench
- > Tightening Torque Force : 20 N.cm
- > Fixture Level Impression

## Temporary Abutment

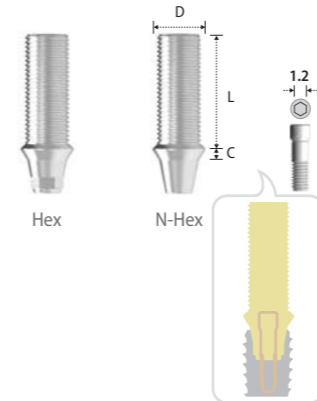

Type	Hex	N-Hex
Diameter	Ø4.5	Ø4.5
Length / Cuff	10	10
1	2STHA45	2STNA45

- > Packing Unit : 1 Abutment + 1 Abutment Screw
- > For Screw-Cement Retained Prosthesis
- > For Provisional Restoration
- > Connected with Abutment Screw (2SSHR100)
- > Tightened with 1.2 Hex Driver and Torque Wrench
- > Tightening Torque Force : 20 N.cm
- > Fixture Level Impression

### Meta G UCLA Abutment

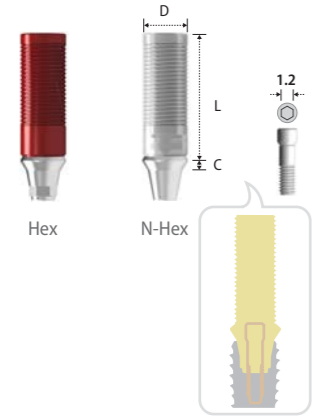

Type	Hex	N-Hex
Diameter	Ø4.5	Ø4.5
Length	12	12
1	2SGH45N	2SGN45N
2	2SGH452N	2SGN452N
3	2SGH453N	2SGN453N

- > Packing Unit : 1 Abutment + 1 Abutment Screw
- > For Screw-Cement or Screw Retained Prosthesis
- > Modification to Angulated Abutment, Customized Abutment and Telescopic Abutment
- > CCM Alloy Core for Precise Connection
- > Cast with Non-Previous Metal or Gold Alloy
- > Connected with Abutment Screw (2SSHR100)
- > Tightened with 1.2 Hex Driver and Torque Wrench
- > Tightening Torque Force : 30 N.cm
- > Fixture Level Impression

### Plastic UCLA Abutment

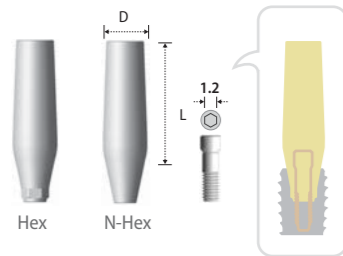

Type	Hex		N-Hex	
Diameter	Ø4.5	Ø5.5	Ø4.5	Ø5.5
14	2SPHR001	2SPHW001	2SPNR001	2SPNW001

- > Packing Unit : 1 Abutment + 1 Abutment Screw
- > Same Purpose of Use as Meta G UCLA Abutment but Low Accuracy of Connection
- > PMMA Material
- > Connected with Abutment Screw (2SSHR100)
- > Tightened with 1.2 Hex Driver and Torque Wrench
- > Tightening Torque Force : Finger Light Force during Wax Pattern Fabrication, 30 N.cm after casting
- > Fixture Level Impression

### Abutment Screw

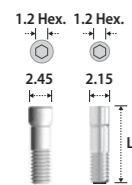

Diameter	2.45	2.15
Length	8.5	8.5
	2SSHR100	2SSHR200

- > Packing Unit : 1 Abutment Screw
- > 2SSHR100: Hybrid Block / Scanbody / Angulated / Milling / Temporary / Meta G UCLA / Plastic UCLA Abutment
- > 2SSHR200: Hybrid S & L Ti-Base / Cemented / Easy Temporary Abutment
- > Tightened with 1.2 Hex Driver and Torque Wrench

### Replica



Length	12
	2SRHR001

- > Packing Unit : 1 Replica
- > Mimicking of Conical Interface of Fixture
- > Analog of Fixture for Cast Model

### Pick-up Impression Coping

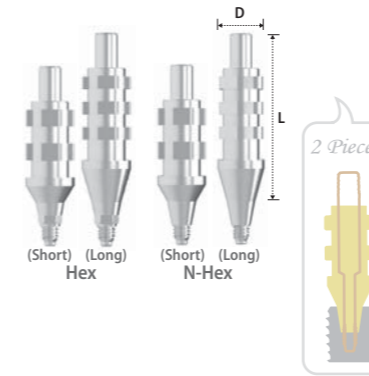

Type	Hex			N-Hex		
Diameter	Ø4.5	Ø5.5	Ø6.5	Ø4.5	Ø5.5	Ø6.5
16 (Short)	2SIH45S	2SIH55S	2SIH65S	2SIN45S	2SIN55S	2SIN65S
20 (Long)	2SIH45L	2SIH55L	2SIH65L	2SIN45L	2SIN55L	2SIN65L

- > Packing Unit : 1 Pick-up Impression Coping + 1 Guide Pin
- > For Open Tray Impression
- > Connected with Guide Pin
- > Tightened with 1.2 Hex Driver and Torque Wrench

### Transfer Post

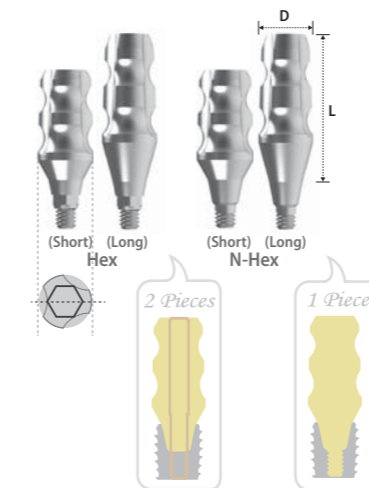

Type	Hex			N-Hex		
Diameter	Ø4.5	Ø5.5	Ø6.5	Ø4.5	Ø5.5	Ø6.5
11 (Short)	2STH45S	2STH55S	2STH65S	2STN45S	2STN55S	2STN65S
15 (Long)	2STH45L	2STH55L	2STH65L	2STN45L	2STN55L	2STN65L

- > Packing Unit : 1 Transfer Post + 1 Guide Pin (Hex) / 1 Transfer Post (N-Hex, Solid Type)
- > For Closed Tray Impression
- > Connected with Guide Pin
- > Tightened with 1.2 Hex Driver and Torque Wrench

### Guide Pin



Length	Type	Pick-up Impression Coping
22.2(Short)		2SISR001SS
26.2(Long)		2SISR001SL



Length	Type	Transfer Post
16.3(Short)		2STH001SS
20.3(Long)		2STH001SL

# Prosthetic Procedure II

## Component Selection Guide for Multi S&A Abutment

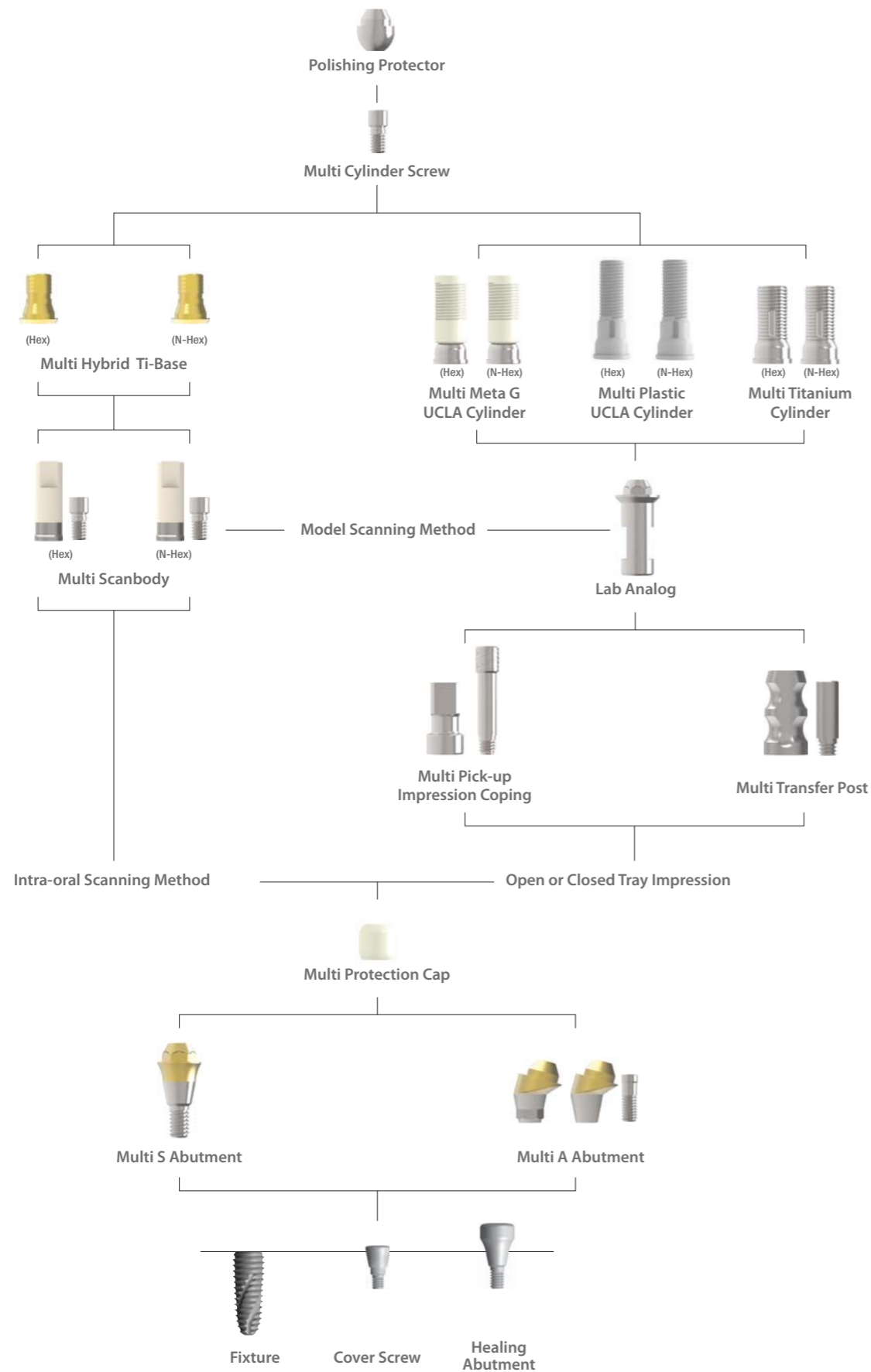

### Multi S Abutment

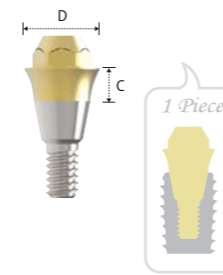

### Multi A Abutment

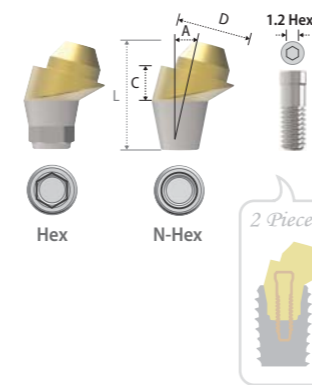

### Abutment Screw

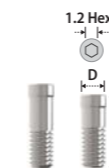

### Multi Protection Cap

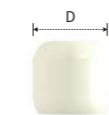

Diameter Cuff	Ø4.5	Ø5.5
1	2SMS451	2SMS551
2	2SMS452	2SMS552
3	2SMS453	2SMS553
4	2SMS454	2SMS554
5	2SMS455	2SMS555

- > Packing Unit : 1 Abutment
- > For Screw-Retained Prosthesis
- > Titanium Base for Cylinder
- > Gold Color for More Translucent Restoration
- > Integrated with Screw and Abutment
- > Library available for EXOCAD®, 3Shape®, Dental Wings® and Others
- > Use S Holder for More Stable Position
- > Tightened with S Machine & S Ratchet Driver and Torque Wrench
- > Tightening Torque Force : 30 N.cm
- > Abutment Level Impression

Type Diameter(Angle) Cuff	Hex			
	Ø4.5(15°)	Ø4.5(30°)	Ø5.5(15°)	Ø5.5(30°)
2	● 2SMAH45152			
3	★ 2SMAH45153	● 2SMAH45303	★ 2SMAH55153	★ 2SMAH55303
4	★ 2SMAH45154	★ 2SMAH45304	★ 2SMAH55154	★ 2SMAH55304
5			★ 2SMAH55155	★ 2SMAH55305

Type Diameter(Angle) Cuff	N-Hex			
	Ø4.5(15°)	Ø4.5(30°)	Ø5.5(15°)	Ø5.5(30°)
2	● 2SMAN45152			
3	★ 2SMAN45153	● 2SMAN45303	★ 2SMAN55153	★ 2SMAN55303
4	★ 2SMAN45154	★ 2SMAN45304	★ 2SMAN55154	★ 2SMAN55304
5			★ 2SMAN55155	★ 2SMAN55305

- > Packing Unit : 1 Abutment + 1 Abutment Screw
- > For Screw-Retained Prosthesis
- > Titanium Base for Cylinder
- > Gold Color for More Translucent Restoration
- > Library available for EXOCAD®, 3Shape®, Dental Wings® and Others
- > Use A Holder for More Stable Position
- > Connected with Abutment Screw ( 2SSHR300 : ★ / 2SSHR400 : ● )
- > Tightened with 1.2 Hex Driver and Torque Wrench
- > Tightening Torque Force : 30 N.cm
- > Abutment Level Impression

Length Diameter	7.5	6.5
2.15	★ 2SSHR300	● 2SSHR400

- > Packing Unit : 1 Abutment Screw
- > For Multi A Abutment
- > Tightened with 1.2 Hex Driver and Torque Wrench
- > Tightening Torque Force : 30 N.cm

Diameter	Ø5.2	Ø6.2
	2SMPC45	2SMPC55

- > Packing Unit : 1 Cap
- > Protection from Cheek and Tongue for Gingival Healing Period
- > Gingival Retraction for Prosthodontic Margin of Abutment
- > Alternative Usage for Sub-structure of Temporary Prosthesis



### Multi Scanbody

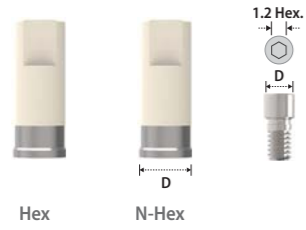

Type	Hex		N-Hex	
Diameter	Ø4.5		Ø4.5	
	2SMB001H		2SMB001N	

- > Packing Unit : 1 Scanbody + 1 Cylinder Screw
- > For both, Model Scanner and Intra Oral Scanner
- > For Multi Hybrid Ti-Base
- > Titanium Core for More Strength and Precision
- > No Need to Spray
- > Connected with Cylinder Screw (2SMCS100)
- > Tightened with 1.2 Hex Driver and Torque Wrench
- > Tightening Torque Force : 15~20 N.cm

### Multi Hybrid Ti-Base

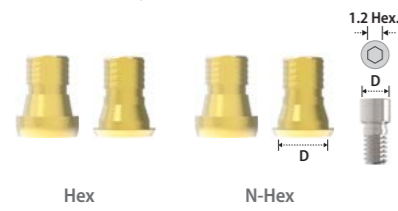

Type	Hex			N-Hex		
Diameter	Ø4.5	Ø4.5	Ø5.5	Ø4.5	Ø4.5	Ø5.5
Cuff	0.5	2SMHT45H	2SMHT55H	2SMHT45N	2SMHT55N	
	1.5	2SMHT40H		2SMHT40N		

- > Packing Unit : 1 Ti-Base + 1 Cylinder Screw
- > For Screw-Cement or Screw Retained Abutment
- > Titanium Base for Strength of CAD/CAM Customized Zirconium Abutment or Crown
- > Gold Color for More Translucent Restoration
- > Cutting Surface for Anti-rotation of Prosthesis
- > Library available for EXOCAD®, 3Shape®, Dental Wings® and Others
- > Connected with Cylinder Screw (2SMCS100)
- > Tightened with 1.2 Hex Driver and Torque Wrench
- > Tightening Torque Force : 30 N/cm
- > Use Scanbody for 3D Work
- > Abutment Level Impression

### Multi Pick-up Impression Coping



Type	Hex		N-Hex	
Diameter	Ø4.5	Ø5.5	Ø4.5	Ø5.5
	2SMIH45	2SMIH55	2SMIN45	2SMIN55

- > Packing Unit : 1 Impression Coping + 1 Guide Pin
- > For Open Tray Impression
- > Connected with Guide Pin
- > Tightened with 1.2 Hex Driver and Torque Wrench

### Multi Transfer Post

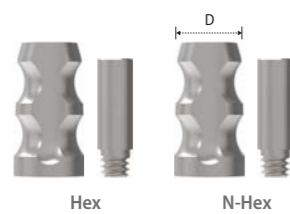

Type	Hex		N-Hex	
Diameter	Ø4.5	Ø5.5	Ø4.5	Ø5.5
	2SMTH45	2SMTH55	2SMTN45	2SMTN55

- > Packing Unit : 1 Transfer Post + 1 Guide Pin
- > For Closed Tray Impression
- > Connected with Guide Pin
- > Tightened with 1.2 Hex Driver and Torque Wrench

### Multi Lab Analog



Diameter	Ø4.5	Ø5.5
	2SMA45	2SMA55

- > Packing Unit : 1 Analog
- > Replacement of Abutment Shape in Cast Model
- > Choose by Abutment Size

### Multi Meta G UCLA Cylinder



Type	Hex		N-Hex	
Diameter	Ø4.5	Ø5.5	Ø4.5	Ø5.5
	2SCCH45	2SCCH55	2SCCN45	2SCCN55

- > Packing Unit : 1 Cylinder + 1 Cylinder Screw
- > For Screw, Cement or Screw-Cement Retained Prosthesis
- > Modification to Various Types of Abutment
- > CCM Alloy Core for Precise Connection
- > Cast with Non-Previous Metal or Gold Alloy
- > Connected with Cylinder Screw
- > Tightened with 1.2 Hex Driver and Torque Wrench
- > Tightening Torque Force : 30 N.cm

### Multi Plastic UCLA Cylinder



Type	Hex		N-Hex	
Diameter	Ø4.5	Ø5.5	Ø4.5	Ø5.5
	2SMPH45	2SMPH55	2SMPN45	2SMPN55

- > Packing Unit : 1 Cylinder + 1 Cylinder Screw
- > For Screw, Cement or Screw-Cement Retained Prosthesis
- > Same Purpose of Use as Meta G UCLA Cylinder but Low Accuracy of Connection
- > PMMA Material
- > Connected with Cylinder Screw
- > Tightened with 1.2 Hex Driver and Torque Wrench
- > Tightening Torque Force : 30 N.cm

### Multi Titanium Cylinder

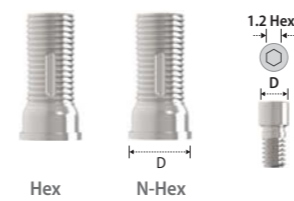

Type	Hex		N-Hex	
Diameter	Ø4.5	Ø5.5	Ø4.5	Ø5.5
	2STCH45	2STCH55	2STCN45	2STCN55

- > Packing Unit : 1 Cylinder + 1 Cylinder Screw
- > For Screw, Cement or Screw-Cement Retained Prosthesis
- > Connected with Cylinder Screw
- > Tightened with 1.2 Hex Driver and Torque Wrench
- > Tightening Torque Force : 30 N.cm

### Multi Cylinder Screw

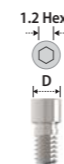

	2SMCS100
--	----------

- > Packing Unit : 1 Cylinder Screw
- > Connected with Meta G UCLA, Plastic UCLA and Titanium Cylinder
- > Tightened with 1.2 Hex Driver and Torque Wrench
- > Tightening Torque Force : 30 N.cm

## Polishing Protector



Diameter	Ø4.5	Ø5.5
	2SMPP45	2SMPP55

- > Packing Unit : 1 Protector
- > For Polishing Work during Lab Procedure

## Holder



S Holder



KMHS01

- > Packing Unit : 1 Holder
- > To Position Multi S Abutment More Stably



A Holder

KMHA01

- > Packing Unit : 1 Holder
- > To Position Multi A Abutment More Stably

## S Machine Driver



KMMSD21L

- > Packing Unit : 1 Driver
- > To Install Multi S Abutment by hand

## S Ratchet Driver

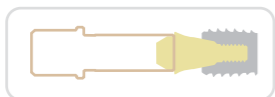

KRMSD15L

- > Packing Unit : 1 Driver
- > To Install Multi S Abutment by Machine

## Multi-Uni Direct Surgical Stent

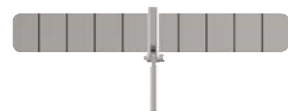

KDSS001

- > To Guide Implant Placement using AO4 or AO6 Technique
- > For more information, please refer to the Page 138.

# Prosthetic Procedure III

## Component Selection Guide for Lock Abutment

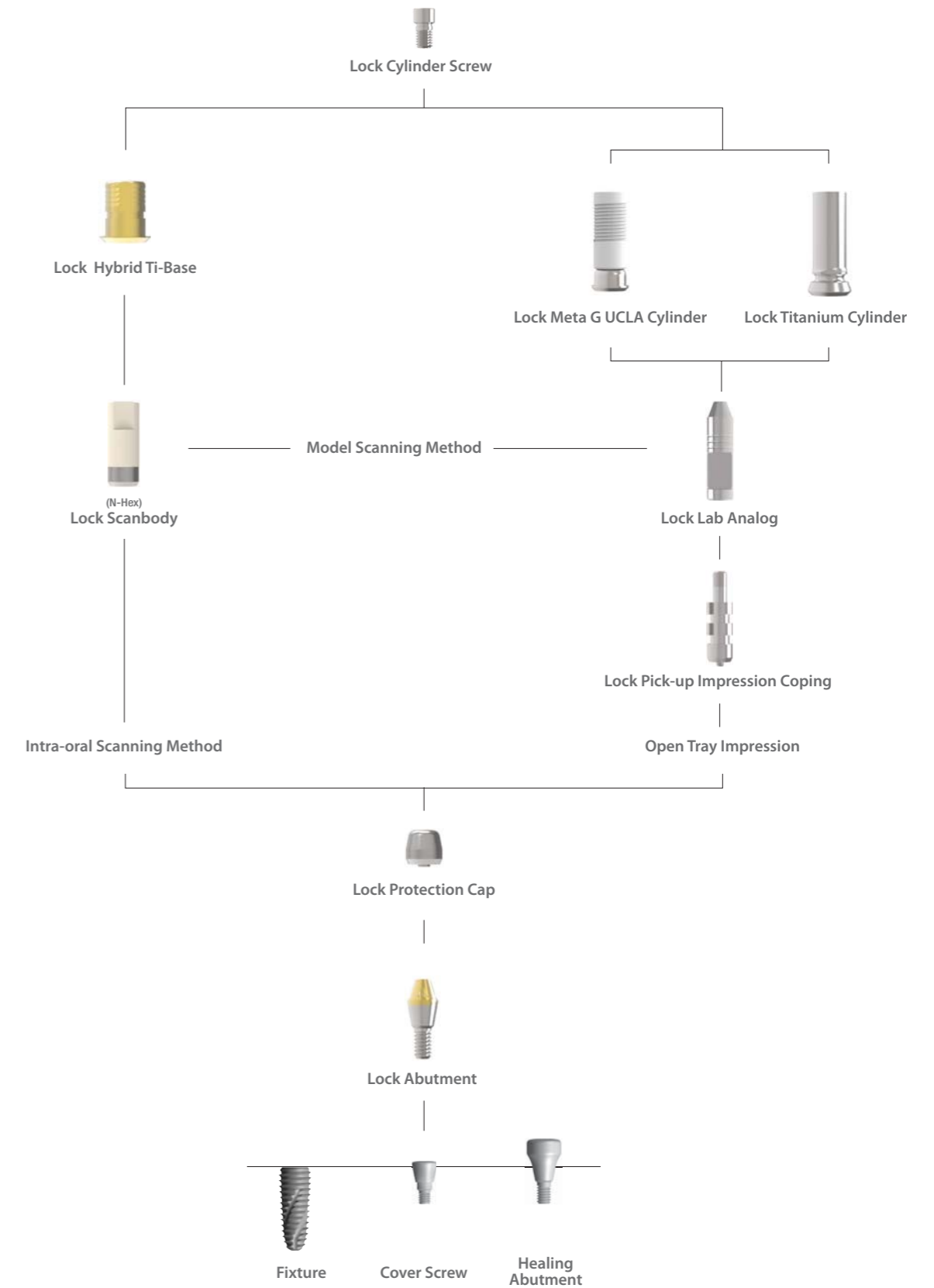

### Lock Abutment



Cuff	Diameter	Part Number
0.5	Ø4.5	2SLA400
1	Ø4.5	2SLA410
2	Ø4.5	2SLA420
3	Ø4.5	2SLA430
4	Ø4.5	2SLA440

- > Packing Unit : 1 Abutment
- > For Screw-Retained Prosthesis
- > Titanium Base for Cylinder
- > Gold Color for More Translucent Restoration
- > Integrated with Screw and Abutment
- > Tightened with Lock Ratchet Driver and Torque Wrench
- > Tightening Torque Force : 30 N.cm
- > Abutment Level Impression

### Lock Protection Cap



Diameter	Part Number
Ø4.5	2SLP45

- > Packing Unit : 1 Cap
- > Protection from Cheek and Tongue for Gingival Healing Period
- > Gingival Retraction for Prosthodontic Margin of Abutment

### Lock Scanbody

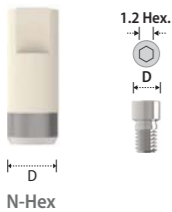

Diameter	Part Number
Ø4.5	2SLB001H

- > Packing Unit : 1 Scanbody + 1 Cylinder Screw
- > For both, Model Scanner and Intra Oral Scanner
- > For Lock Hybrid Ti-Base
- > Titanium Core for More Strength and Precision
- > No Need to Spray
- > Connected with Cylinder Screw (2SMCS200)
- > Tightened with 1.2 Hex Driver and Torque Wrench
- > Tightening Torque Force : 15~20 N.cm

### Lock Hybrid Ti-Base

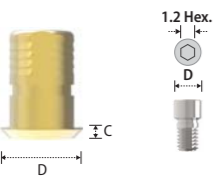

Diameter	Part Number
Ø4.5	2SLHT40N

- > Packing Unit : 1 Ti-Base + 1 Cylinder Screw
- > For Screw-Cement or Screw Retained Abutment
- > Titanium Base for Strength of CAD/CAM Customized Zirconium Abutment or Crown
- > Gold Color for More Translucent Restoration
- > Cutting Surface for Anti-rotation of Prosthesis
- > Library available for EXOCAD®, 3Shape®, Dental Wings® and Others
- > Connected with Cylinder Screw (2SMCS200)
- > Tightened with 1.2 Hex Driver and Torque Wrench
- > Tightening Torque Force : 30 N.cm
- > Use Scanbody for 3D Work
- > Abutment Level Impression

### Lock Pick-up Impression Coping



Diameter	Part Number
Ø4.5	2SLIH45

- > Packing Unit : 1 Impression Coping + 1 Guide Pin
- > For Open Tray Impression

### Lock Lab Analog



Diameter	Part Number
Ø4.5	2SLA45

- > Packing Unit : 1 Analog
- > Replacement of Abutment Shape in Cast Model
- > Connected with Guide Pin
- > Tightened with 1.2 Hex Driver and Torque Wrench

### Lock Meta G UCLA Cylinder



Diameter	Part Number
Ø4.5	2SLCH45

- > Packing Unit : 1 Cylinder + 1 Cylinder Screw
- > For Screw, Cement or Screw-Cement Retained Prosthesis
- > Modification to Various Types of Abutment
- > CCM Alloy Core for Precise Connection
- > Cast with Non-Previous Metal or Gold Alloy
- > Connected with Cylinder Screw
- > Tightened with 1.2 Hex Driver and Torque Wrench
- > Tightening Torque Force : 30 N.cm

### Lock Titanium Cylinder



Diameter	Part Number
Ø4.5	2SLTH45

- > Packing Unit : 1 Cylinder + 1 Cylinder Screw
- > For Screw, Cement or Screw-Cement Retained Prosthesis
- > Connected with Cylinder Screw
- > Tightened with 1.2 Hex Driver and Torque Wrench
- > Tightening Torque Force : 30 N.cm

### Lock Cylinder Screw



Part Number
2SLCS200

- > Packing Unit : 1 Cylinder Screw
- > Connected with CCM Cylinder or Titanium Cylinder
- > Tightened with 1.2 Hex Driver and Torque Wrench
- > Tightening Torque Force : 30 N.cm

### Lock Ratchet Driver

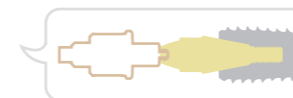

Part Number
KRLRD18

- > Packing Unit : 1 Driver
- > To Install Lock Abutment by Hand

### Multi-Uni Direct Surgical Stent

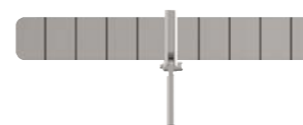

Part Number
KDSS001

- > To Guide Implant Placement using AO4 or AO6 Technique
- > For more information, please refer to Page 138.

# Prosthetic Procedure IV

## Component Selection Guide for Absolute Abutment

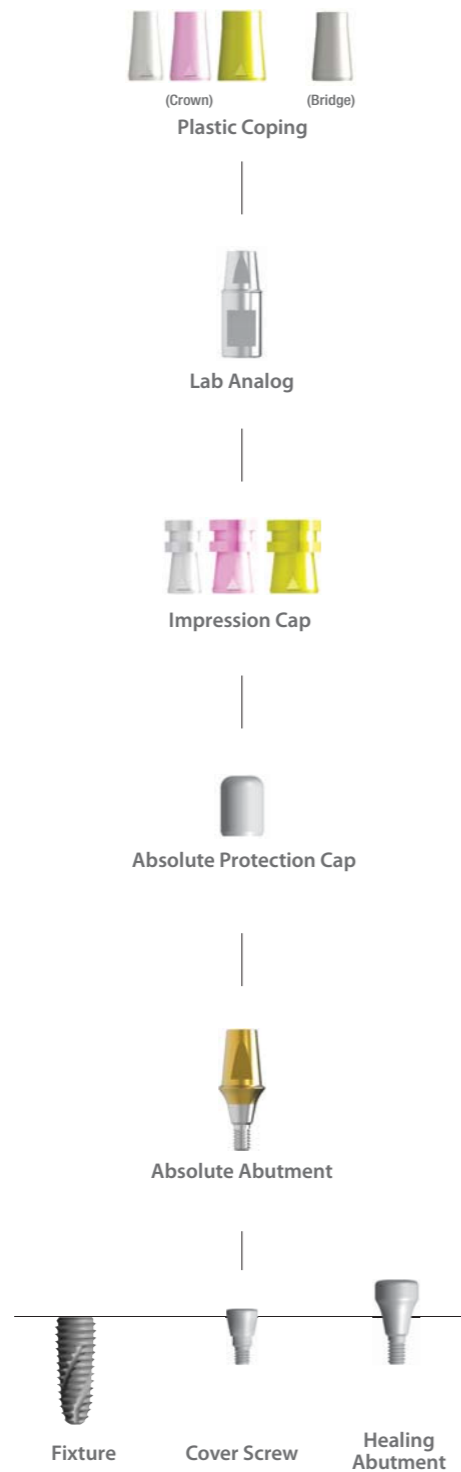

### Absolute Abutment

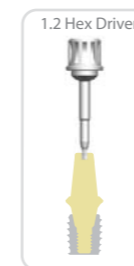

Diameter Length Cuff	Ø4.5			Ø5.5		
	4	5.5	7	4	5.5	7
1	2SAC4514	2SAC4515	2SAC4517	2SAC5514	2SAC5515	2SAC5517
2	2SAC4524	2SAC4525	2SAC4527	2SAC5524	2SAC5525	2SAC5527
3	2SAC4534	2SAC4535	2SAC4537	2SAC5534	2SAC5535	2SAC5537
4	2SAC4544	2SAC4545	2SAC4547	2SAC5544	2SAC5545	2SAC5547
5	2SAC4554	2SAC4555	2SAC4557	2SAC5554	2SAC5555	2SAC5557

Diameter Length Cuff	Ø6.5		
	4	5.5	7
1	2SAC6514	2SAC6515	2SAC6517
2	2SAC6524	2SAC6525	2SAC6527
3	2SAC6534	2SAC6535	2SAC6537
4	2SAC6544	2SAC6545	2SAC6547
5	2SAC6554	2SAC6555	2SAC6557

- > Packing Unit : 1 Abutment + 1 Production Cap
- > For Cement Retained Prosthesis
- > Cutting Surface for Anti-rotation of Prosthesis
- > Integrated with Screw and Abutment
- > Tightened with 1.2 Hex Driver and Torque Wrench
- > Tightening Torque Force : 30 N.cm
- > Abutment Level Impression

### Absolute Protection Cap



Diameter Length	Ø5.0	Ø6.0	Ø7.0
6	2SHPC454	2SHPC554	2SHPC654
7.5	2SHPC455	2SHPC555	2SHPC655
9	2SHPC457	2SHPC557	2SHPC657

- > Packing Unit : 1 Cap
- > Protection from Cheek and Tongue for Gingival Healing Period
- > Gingival Retraction for Prosthodontic Margin of Abutment
- > Alternative Usage for Sub-structure of Temporary Prosthesis

### Absolute Impression Cap



Abut. Dia. Length	Ø4.5	Ø5.5	Ø6.5
10.3	2SIC45	2SIC55	2SIC65

- > Packing Unit : 1 Cap
- > Confirm Locking with Abutment by Rotation of Clockwise and Anti-clockwise Direction

### Absolute Lab Analog



Diameter Length	Ø4.5	Ø5.5	Ø6.5
4.1	2SHLA454	2SHLA554	2SHLA654
5.6	2SHLA455	2SHLA555	2SHLA655
7.1	2SHLA457	2SHLA557	2SHLA657

- > Packing Unit : 1 Analog
- > Replacement of Abutment Shape in Cast Model
- > Choose According to Width and Length of Abutment

### Absolute Plastic Coping (Burn Out Cylinder)



Type Abut. Dia. Length	Crown			Bridge		
	Ø4.5	Ø5.5	Ø6.5	Ø4.5	Ø5.5	Ø6.5
10	2SHBC45	2SHBC55	2SHBC65	2SHBB45	2SHBB55	2SHBB65

- > Packing Unit : 1 Coping
- > Connected with Lab Analog
- > Burnout and Casting for Metal Framework

# Prosthetic Procedure V

## Component Selection Guide for Straight Abutment

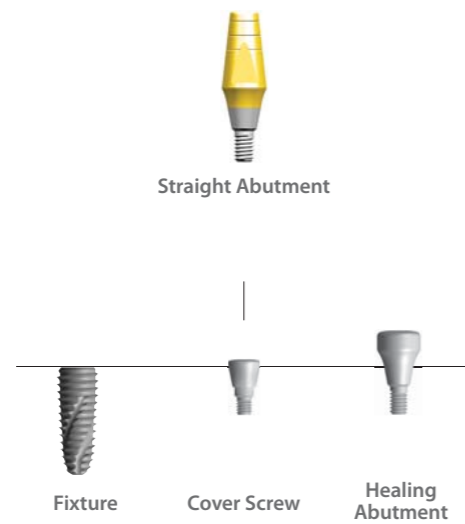

Straight Abutment

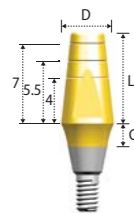

Diameter	Ø3.5	Ø4.5
Length	8	8
Cuff		
0.5	2SSCM308	2SSCR408
1	2SSCM318	2SSCR418
2	2SSCM328	2SSCR428
3	2SSCM338	2SSCR438
4	2SSCM348	2SSCR448

- > Packing Unit : 1 Abutment
- > For Cement Retained Prosthesis
- > Integrated with Screw and Abutment
- > Tightened with Shoulder Driver
- > Tightening Torque Force : 30 N.cm
- > Direct Impression

Shoulder Driver

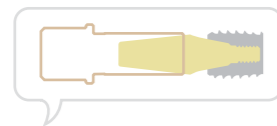

Diameter	Ø4.0
	KRR19L

- > Packing Unit : 1 Driver
- > To Install Straight Abutment

# Prosthetic Procedure VI

## Component Selection Guide for Sonator Abutment

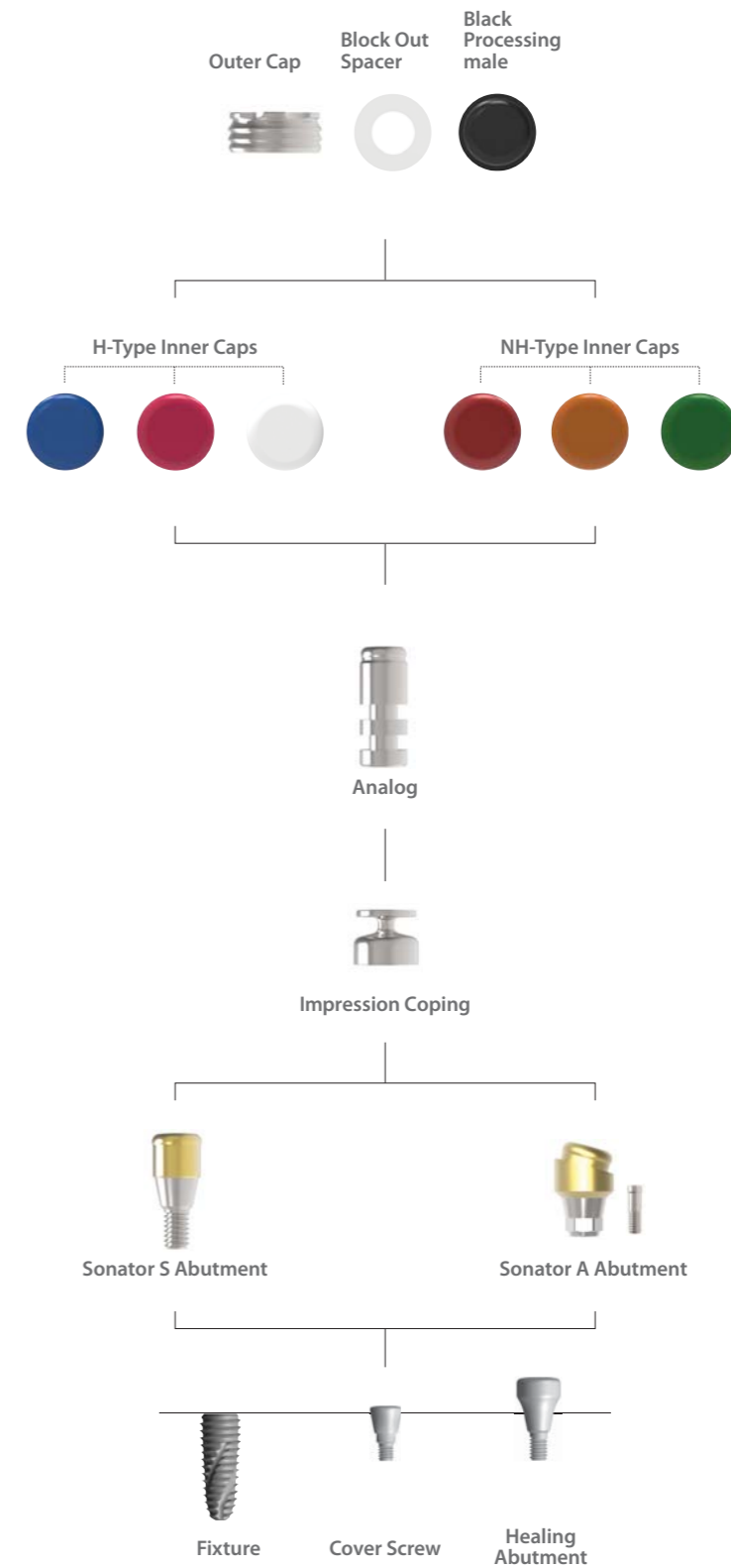

### Sonator S Abutment

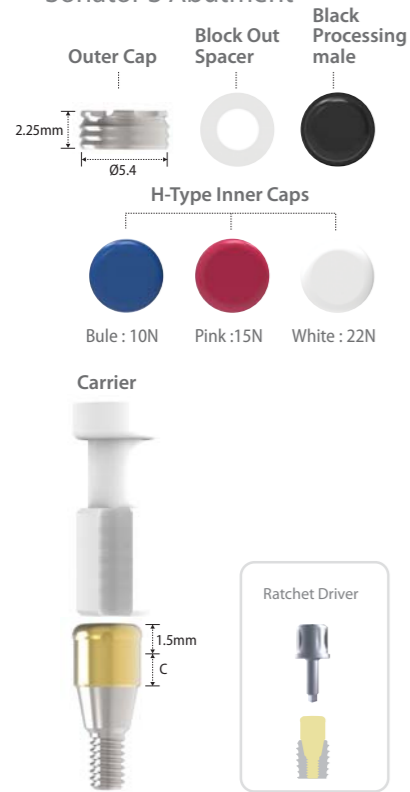

Diameter	Ø4.0					
Cuff Length	1	2	3	4	5	6
1.5	SONS401	SONS402	SONS403	SONS404	SONS405	SONS406

- > Packing Unit : Sonator S Abutment + Carrier + 3 H-Type Inner Caps + Outer Cap + Block-out Spacer + Black Processing Male
- > For Implant Supported Over-denture Prosthesis
- > Stable with Low Vertical Height
- > 6 kinds of Inner Caps give various holding force(Both, H and NH-Type Inner Caps are used for Sonator S Abutment)
- > Path Compensation up to 40° based on 2 Implants
- > Carrier : Used for delivery of the abutment
- > Tightened with Sonator S Ratchet Driver and Torque Wrench
- > Tightening Torque Force : 30 N.cm
- > Abutment Level Impression

### Sonator A Abutment

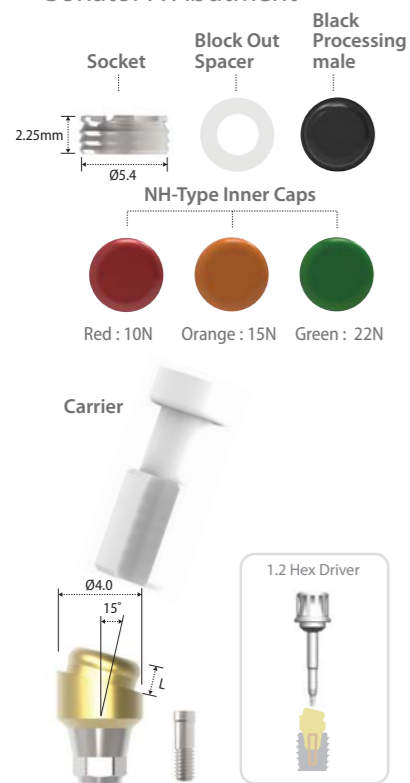

Diameter	Ø4.0	
Angle Cuff	1.5	3.0
15°	SONA415	SONA430

- > Packing Unit : Sonator A Abutment + Abutment Screw + Carrier + 3 NH-Type Inner Caps + Outer Cap + Block-out Spacer + Black Processing Male
- > For Implant Supported Over-denture Prosthesis
- > Stable with Low Vertical Height
- > 6 kinds of Inner Caps give various holding force (Both, H and NH-Type Inner Caps are used for Sonator A Abutment)
- > Path Compensation up to 35° based on 2 Implants
- > Connected with Abutment Screw (2SSHR330)
- > Carrier : Used for delivery of the abutment
- > Tightened with 1.2 Hex Driver and Torque wrench
- > Tightening Torque Force : 30 N.cm
- > Abutment Level Impression

### Abutment Screw



2SSHR300
----------

### Outer Cap

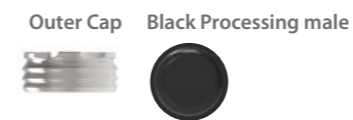

Code	SONOC01
> Packing Unit : 2 Outer Caps and 2 Black Processing Male	
> Black Processing Male: Inserted and Removed with I&R Driver	

### H-Type Inner Cap

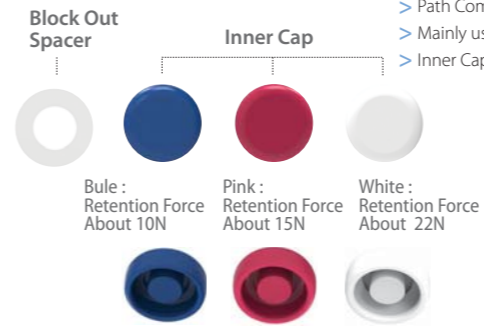

Code	SONIC01
> Packing Unit : 3 Block-out Spacers + 3 Inner Caps (1 Blue , 1 Pink and 1 White)	
> Path Compensation up to 40° based on 2 Implants	
> Mainly used for Sonator S Abutment	
> Inner Caps: Inserted and Removed with I&R Driver	

### NH-Type Inner Cap

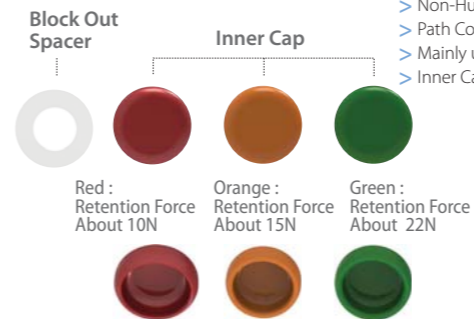

Code	SONIC02
> Packing Unit : 3 Block-out Spacers + 3 Inner Caps (1 Red , 1 Orange and 1 Green)	
> Non-Humped Design	
> Path Compensation up to 20° based on 2 Implants	
> Mainly used for Sonator A Abutment	
> Inner Caps : Inserted and Removed with I&R Driver	

### Sonator Impression Coping



Length	4.4
SONIP04	
> Packing Unit : 4 Impression Copings	
> Connected over Sonator Abutment after Placing Block-out Spacer	
> For Close Tray Impression	

### Sonator Lab Analog



Length	10.2
SONLA04	
> Packing Unit : 4 Lab Analogs	
> Replacement of Abutment Shape in Cast Model	

### Sonator S Ratchet Driver



Diameter	Ø3.1
Length	18
	SONRD19L

> Used to Tighten and Untighten Sonator S Abutment

### Hex Driver



Type	Machine
Hex Length	Hex 1.2
22(Short)	KMD12S
28(Long)	KMD12L

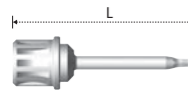

Type	Ratchet
Hex Length	Hex 1.2
15(Short)	KHD1215
21(Long)	KHD1221
27(X-Long)	KHD1227

> Used to Tighten and Untighten Sonator A Abutment  
 > Machine Drivers are used with Contra Angle and Ratchet Drivers are used with Torque Wrench

### Torque Wrench



Code	KTW001
------	--------

> Used with Ratchet Driver and 1.2 Hex Driver  
 > Torque force at 10 / 25 / 30 / 35 N.cm to be controlled by pulling elastic bar  
 > Maximal 120 N.cm torque force by pulling the rigid main bar

### I & R Driver

	SONIR002
--	----------



> Used to Insert and Remove Inner Caps and Block Processing Male

# Prosthetic Procedure VII

## Component Selection Guide for Ball Abutment

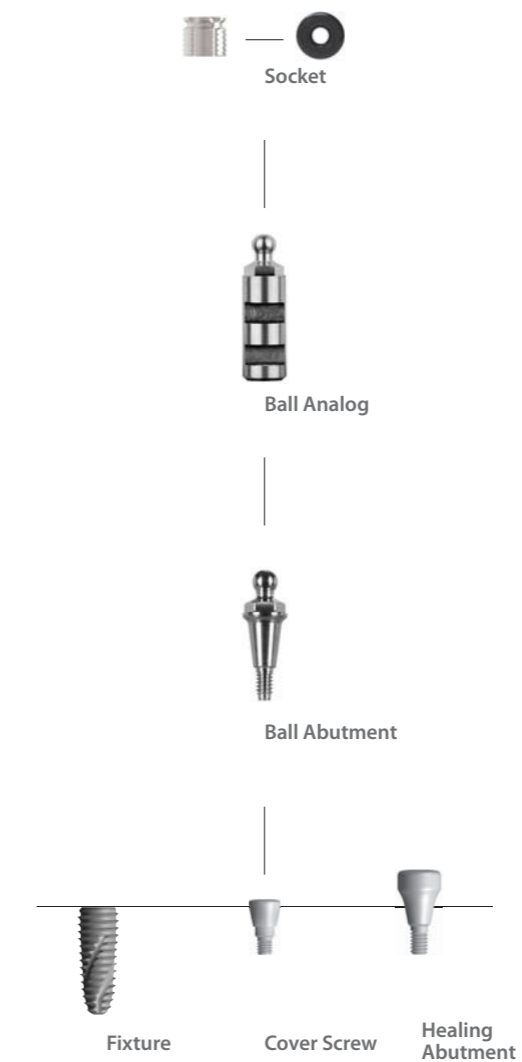

## Ball Abutment

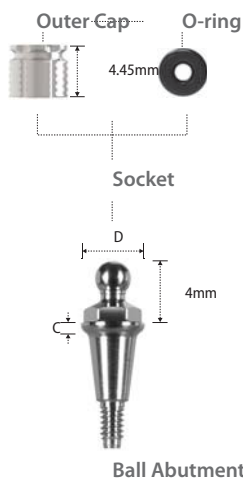

Cuff	Diameter	
1	Ø4.0	2SBAT414R
2		2SBAT424R
3		2SBAT434R
4		2SBAT444R
5		2SBAT454R

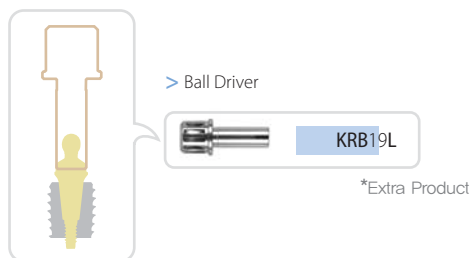

- > Packing Unit : 1 Ball Abutment + 1 Socket (1 Outer Cap + 1 O-ring)
- > For Implant Supported Over-denture Prosthesis
- > Tightened with Ball Driver and Torque Wrench
- > Tightening Torque Force : 30 N.cm
- > Direct Impression

## Socket



BATC004
---------

- > Packing Unit : 4 Sockets

## Outer Cap



BATC003C
----------

- > Packing Unit : 2 Outer Caps

## O-ring



BATC003I
----------

- > Packing Unit : 4 O-rings

## Ball Analog



Length	Diameter	
4	Ø4.0	SBAL400

- > Packing Unit : 4 Lab Analogs
- > Replacement of Abutment Shape in Cast Model