



NOISE AND VIBRATION ENGINEERING FOR RAIL TRANSPORT



D2S International

Ambachtenlaan 54
3001 Heverlee
Belgium

www.d2sint.com
d2sint@d2sint.com

T + 32 16 23 89 88

NOISE & VIBRATION ENGINEERING

D2S International is active worldwide in all fields of railway noise, vibrations and dynamics of vehicles, track and wheel/rail interaction, superstructures and wear simulations.



NOISE & VIBRATION IMPACT STUDIES

D2S International offers integrated noise and vibration studies and solutions from the tender phase over the design to the validation during operation.

Noise and Vibration Assessment

D2S International has the capabilities to offer its clients an integrated support towards noise and vibrations:

- D2S International assists in preparing tender documents (with respect to noise and vibration).
- D2S International analyses local legislation and normative reference.
- D2S International performs noise and vibration measurements to characterise the initial situation (before construction).
- D2S International does site surveys and categorises buildings and soils along the alignment.
- D2S International makes numerical simulations and predictions for air borne noise, ground borne noise and vibrations in different scenarios.
- D2S International designs and optimises mitigation measures (track and vehicle design) or assists in material selection.
- D2S International makes laboratory tests of the track systems.
- D2S International optimises acoustic comfort inside stations and vehicles.
- D2S International supervises during construction and verifies the performance on site during operation.
- During operation, D2S International provides continuous (24/7) or regular noise and vibration monitoring.

D2S International guarantees the performance of its designs and solutions.



SIMULATIONS

D2S International carries out numerical simulations and predictions for airborne noise, structure borne noise, electro acoustics, ground borne noise and vibrations.

D2S International has a wide range of software tools to simulate noise and vibrations in open air, inside buildings or inside vehicles.

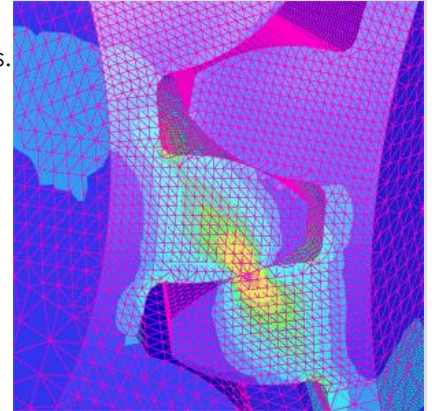

Air borne noise

Air borne noise simulations take into account:

- topography of the area;
- building heights;
- acoustic emission spectra of rolling stock;
- vehicle speed profiles;
- track alignment and track type.

Noise levels generated in the environment are calculated, using the environmental noise calculation software. This software integrates all existing algorithms for environmental noise calculations, including (but not restricted to) NMPB - XP S 31-133, ISO 9613-2, RLS-90, DIN 18005, StL-86, VDI 2571/VDI 2714/VDI 2720, Schall 03, Transrapid, Semibel, CRN, CRTN, SRM II, TemaNord 1996:524 & 525, ÖAL 28, Ö-Norm S5011, RVS 3.02.

The study results include but are not limited to:

- production of noise maps without considering mitigation measures;
- comparison between calculated noise levels and noise criteria;
- selection of the mitigation measures if required;
- production of noise maps with consideration of the selected mitigation measures.

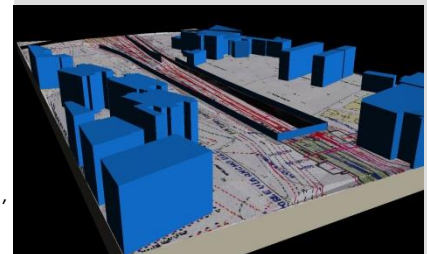
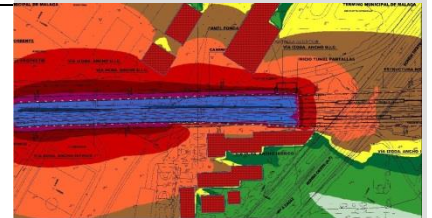

Ground borne noise

D2S International uses a comprehensive methodology to predict ground borne noise levels in buildings along tram, metro and railway lines:

- Analytical techniques, finite element techniques and measurement methods are available for characterisation of the vibration sources and modelling of the transmission of the vibrations through the soil.
- Various techniques are applied to take into account the interaction between soil and building foundations and to predict the noise and vibration levels inside the buildings.

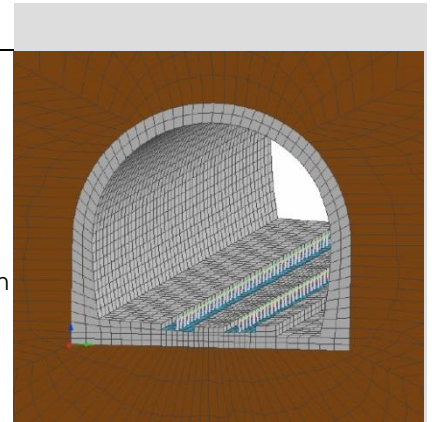

Structure borne noise

Structures such as viaducts or bridges radiate noise when they are exposed to vibration sources. D2S International simulates this noise with dedicated software and designs solutions to mitigate the structure borne noise.

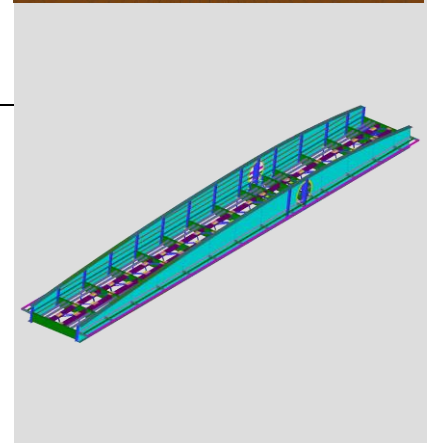

Electro acoustics

Electro acoustic simulations are made in order to design PA systems in railway stations or to optimise the acoustics inside railway vehicles.

The design of PA systems includes the simulation of the Speech Transmission Index (STI), Rapid Speech Transmission Index (RASTI), reverberation time or acoustic clarity for different configurations of the loudspeakers. The simulations result in an optimal acoustical design of the PA systems. Background noise levels, absorptive elements, position and type of loudspeakers are taken into account. These simulations are supported by the measurement capabilities of D2S International.

Vehicle interior noise simulations result in an optimal acoustical comfort and safety for passengers.

Dedicated software is used to perform these simulations.

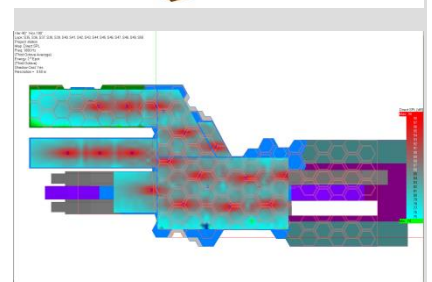
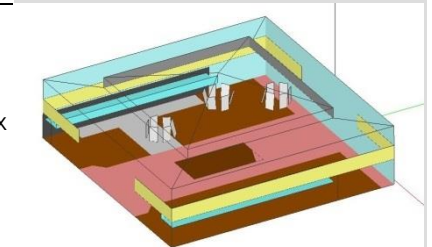

Vibrations

D2S International carries out simulations of vibrations (e.g. vibration maps) for new, existing or upgraded rail infrastructure. The different parameters that are taken into account are the soil characteristics, operational speed, vehicle characteristics (such as wheel quality, wheel diameter, non-suspended mass, suspended mass, bogie characteristics, ...), track conditions (rail quality, track stiffness, sleeper interspacing, ...). Based on these calculated vibration levels, existing mitigation measures are proposed or new mitigation measures are designed.

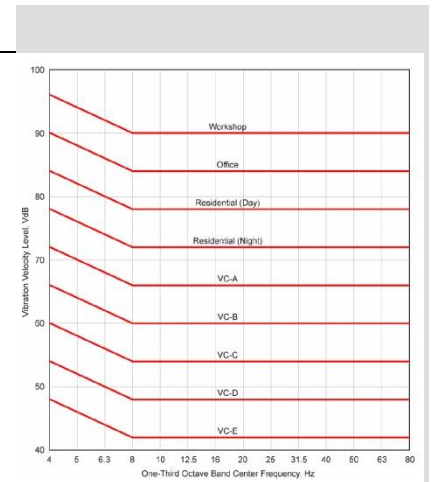

Wheel/Rail noise

WR-NOISE is a program, developed by D2S International, that calculates the wayside noise generated by a railroad wheel rolling on a straight track.

The successive stages are:

- the roughness of the surfaces in contact produces a vertical displacement at the wheel/rail contact. This displacement is characterised by the load/velocity relation imposed by wheel and rail vertical mechanical impedances.
- that displacement induces vertical and transversal responses in the wheel and rail, corresponding to their mechanical impedances. The vertical response of the rail induces transmission of vibrations to the sleepers and, if necessary, to the girder if the track lies on an elevated structure.
- the responses of all these elements (wheel, rail, sleeper and girder) generate acoustic radiation which, finally, through the contact area filter and the radiation efficiencies, produces the wayside noise.

As output of WR-NOISE, the program plots all physical quantities that appear in the model:

- roughness data;
- wheel and rail impedances and admittances;
- contact area filter attenuation;
- radiation efficiencies of all elements;
- radiated acoustic powers of all elements and total radiated acoustic power;
- average spectral vertical and horizontal velocities of wheel and rail;
- sound pressure levels at distance d of the track;
- rail acceleration;
- coupling factor between sleeper and girder;
- rail-sleeper transfer function;
- rail loss factor.

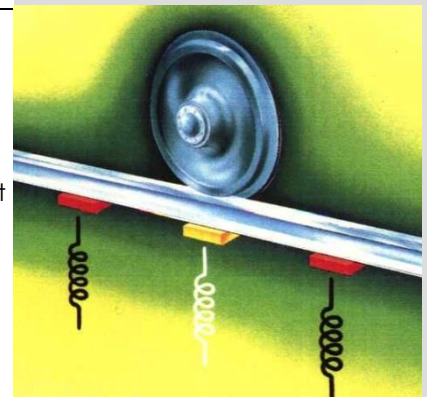

Noise mapping European Directive 2002/49/EC

D2S International generates strategical noise maps in cities according to the European Directives.

D2S International is equipped with the software and experience to perform strategic noise mapping according to the European Directive 2002/49/EC and including all adaptations of recommendation 2003/613/EC.

Strategic noise mapping is more than noise maps only.

Strategic Noise Mapping includes:

- the production of strategic noise maps;
- the determination of the number of people exposed;
- the preservation of quiet areas;
- action planning.

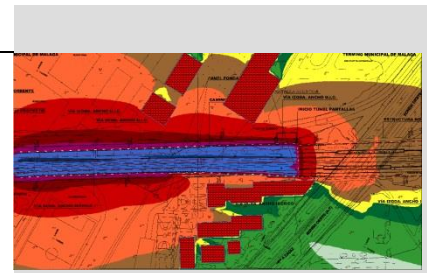
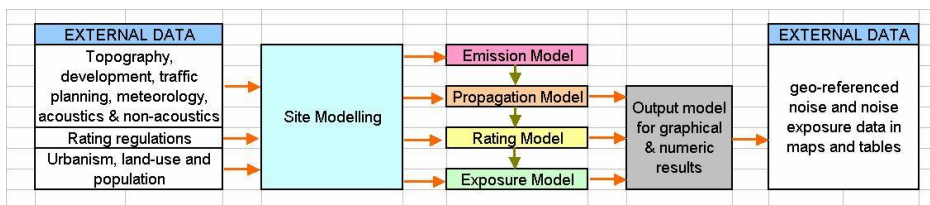

Wheel/Rail Interface Analysis and Wheel/Rail Wear Simulations

D2S International has the technological capabilities and required experience to simulate the wheel/rail contact and, even more importantly, simulate the wheel and rail wear (based on Archard's abrasive wear theory).

Over the last few years, technological advancements have allowed to accurately model rolling stock and track considering different operational conditions (i.e. speed regimes,...) , using all relevant track and vehicle parameters (such as wheel and rail profiles, steel hardness, masses, curvatures, superelevation, vehicle suspensions, etc).

A designated plugin for the multi-body software, allows to accurately calculate and visualize the wheel rail contact and predict wheel and rail wear. These capabilities are used for problem solving/diagnostics (such as excessive rail or wheel wear), wear optimizations or even to assist in strategic decisions (such as which rail profiles to grind).

D2S International is also equipped to measure wheel and rail profiles to validate the models or to gather required input data.

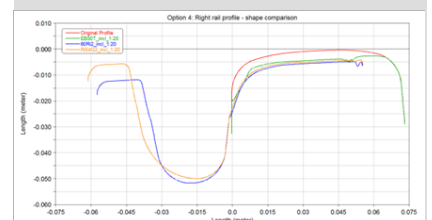
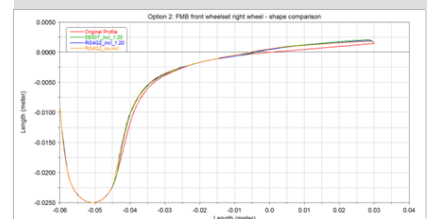
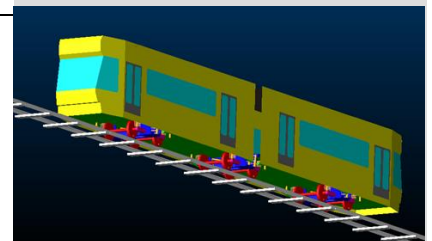
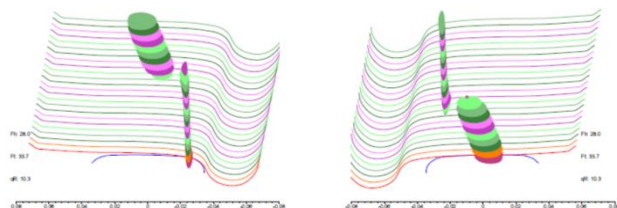

MULTI BODY SIMULATIONS

Multi body simulation technology

Based on multi body simulation technology, D2S International uses tools to accurately predict vehicle and bogie behaviour.

Several crucial aspects are evaluated such as flexibility of the vehicle, crashworthiness of the vehicle, comfort indexes (ISO 2631/1, Wz, Nmv (UIC513), Sy and Sz (UIC518)...), curve analysis (derailment ratio, wheel unloading, EN14363 homologation...), clearance with respect to tunnel walls and other closely placed objects, impact analysis against dead-end track stop, loads prediction in the overhead system and pantograph ...

Flexibility analysis of vehicle

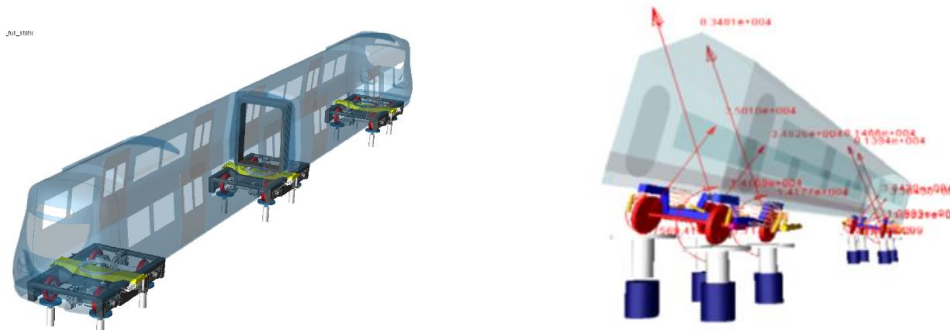

Crash simulation

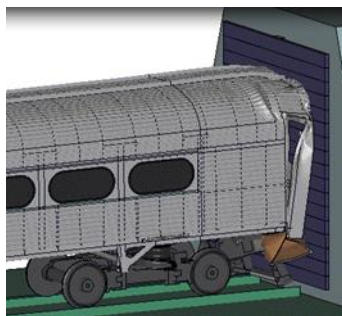

Body torsion interaction with bogie hunting

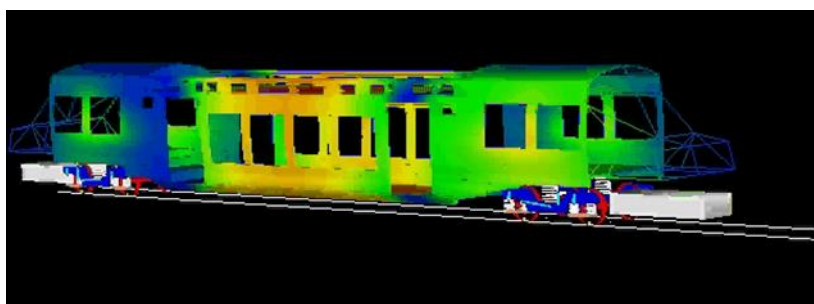

Clearance simulation

name=UUU1

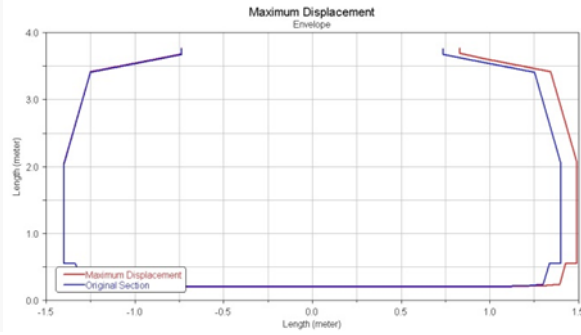
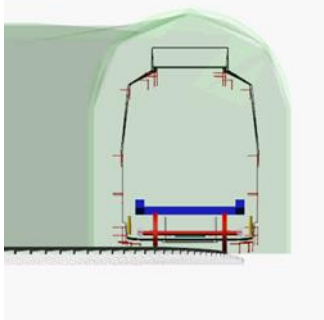

Loads simulation in overhead system and pantograph

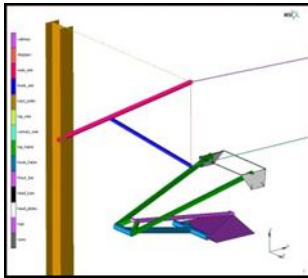

MEASUREMENTS

D2S International has a wide range of measurement equipment for all kind of parameters, situations and environments.

Displacement

Displacement measurements are performed on rails, sleepers, on the concrete slab or inside the ballast or soil to verify the dynamic behaviour of railway track.

Large displacements can give rise to increased rail stresses, fatigue cracking or sleeper and ballast deterioration.

Displacement measurements are performed as part of acceptance tests for new track, during regular monitoring to guarantee safety or to study the dynamics of the transportation system. LVDT sensors are used for this kind of monitoring.



Geotechnical measurements

D2S International is equipped to measure parameters in soils such as pressure, settlement, humidity, temperature, displacements and many more. The measurements are used to monitor or study the dynamic behaviour of soils, exposed to train passage.



Noise

D2S International owns high quality microphones to perform pass-by or 24 hour noise measurements.

Noise measurement are performed for determination of noise emissions from rolling stock (ISO 3095), background measurements, in stations (STI index, RASTI, reverberation time), ISO 1996, ...



Rail Roughness

D2S International operates a Rail Surface Analyser to perform rail roughness measurements.

Rail roughness measurements are performed according to the applicable standards in order to:

- qualify a site as a candidate to perform rolling stock noise type tests;
- survey rail corrugation and rail roughness;
- evaluate rail quality before and after grinding.



Ride Quality

In accordance with the design requirements, D2S International performs ride quality measurements at the centre of the vehicle body and above the bogie pivot points on the vehicle floor. Vibration measurements on seats and wall surfaces are made. Any item that exhibits resonance is investigated and the cause of the resonance identified.

Accelerometers with flat response characteristics from 0.5 Hz on (battery operated) are used with simultaneous acquisition of the signals. Acquisition of data is normally done on a tangent track successively at different speeds: 20 km/h, 40 km/h, 60 km/h and 80 km/h in both running directions.

The test procedure is in accordance with UIC 518.



Stress and Strain

Stress and strain measurements in rails, sleepers, tunnels, viaducts, ... are performed for life-time evaluations and troubleshooting.

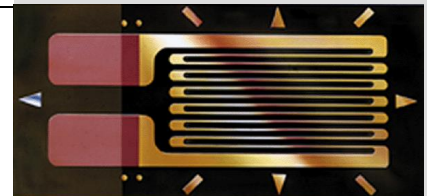

Track Decay Rates

The measurement of track decay rates is mostly used as input data in noise simulation software.

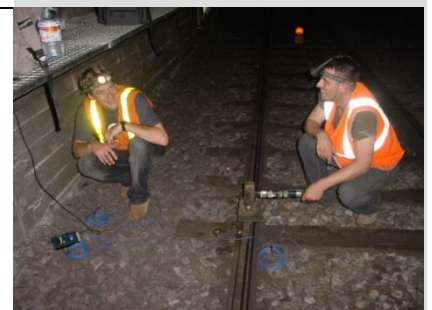

Transfer and Line Source Mobilities

Soil mobilities are measured to be used in vibration calculation methods.



Vibrations

D2S International owns a large number of specific accelerometers to measure vibrations of structures, soils and trackwork components.

Vibration measurements are performed with respect to the local or international standards (ISO2631, DIN4150, SBR, ...).

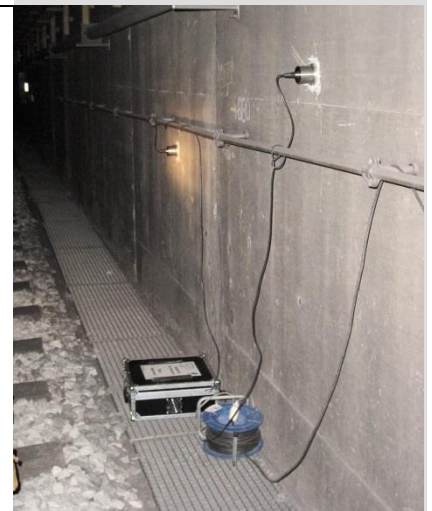

EMC Tests

D2S International uses magnetic and electric field antennas to measure the radiated emissions generated by the complete vehicle whilst stationary and slow moving, according to the European standard on electromagnetic compatibility EN50121-3-1:2006.

The antennas are placed at a distance of 10 m from the track's centreline and are connected to an EMI receiver for evaluation.

Magnetic field antennas on the track are also used to measure the located magnetic fields (frequency up to 2 MHz) generated by the train units under frame, according to the European standard on CLC/TS 50238-3:2013.



ANTI-VIBRATION TRACKS

D2S International did design a large range of innovative vibration isolation solutions at the track level, as a complement to existing solutions. Below are some illustrative examples.

Pre-loaded fixation system (all transport modes)

Pre-loaded fixation systems are discrete rail fasteners with a highly resilient under sleeper or base plate pad. The resilient pad is pre-compressed by specially designed springs with a load, which is about 80 % of the normal static load on the fastener during vehicle passage. The pre-loading spring is completely unloaded during vehicle passage and hence no vibration transmission to the environment takes place through this rigid spring. A soft retaining spring inside the rigid pre-loading spring ensures the stability of the system. The vertical rail deflection during vehicle passage is controlled and limited by the pre-compression of the resilient pad, giving a small additional static deflection during vehicle passage.

The resilient pad consists of an elastomer that has a low dynamic to static spring rate and excellent electrical resistance and thermal stability. The dynamic stiffness of the system can be as low as 5 kN/mm (at 20 Hz), ensuring a first wheel-rail vertical resonance below 20 Hz and hence excellent vibration isolation characteristics, comparable to those of the floating slab.

Improved soft twin bloc sleeper system (all transport modes)

The classic twin bloc sleepers in rubber boots have become a very popular track design because of the simplicity of installation and the reasonably good vibration isolation characteristics. However, for highly resilient configuration, they present a major problem: due to the form of the concrete blocs, the rail is not free to move downward, leading to inefficiency in vibration mitigation.

The D2S International soft twin bloc system retains the simplicity of installation of the conventional system. It integrates readily available standard concrete dual bloc sleepers as used for ballasted track, and offers a significant improvement in vibration isolation thanks to a highly resilient sleeper pad coupled with a specially designed rubber boot.

Performance

- 6 dB gain in vibration isolation over the classic twin bloc sleeper system;
- friction free vertical rail displacements;
- stable track conditions;
- simplicity of installation and replacement.



Fastenerless embedded tracks (tramway)

In classical continuously supported embedded tracks, one elastomer is poured around and below the rail. To ensure proper track stability this elastomer has to be stiff, which results in poor vibration isolation characteristics.

D2S International has designed a continuously supported resilient track system consisting of two different elastomers:

- one soft elastomer around the rail foot;
- one stiff elastomer around the rail web.

The stiff layer sticks to the rail, but is free to move in the vertical direction relative to the surrounding concrete slab. Vertical grooves on the interface between this stiff layer and surrounding concrete slab enable to suppress any longitudinal displacement of the track. This track fixation system has been successfully tested:

- in lab (static, dynamic and fatigue tests);
- numerically (finite element method);
- in test tracks.

The transfer functions measured on D2S International embedded track show no significant resonance. In comparison with the conventional embedded tracks, they are highly damped, what is important to prevent corrugation development.



Hybrid embedded tracks (tramway)

Continuously embedded rail and discrete fastening systems are combined in a hybrid resilient track system in order to combine the advantages of both systems:

- low radiated noise level;
- good vibration isolation;
- possibility to replace the rails in a short time, under operating conditions, without damaging the road surface.

The first wheel-rail resonance of this system can be tuned to 40 Hz or even 30 Hz, depending on the selected rail pads. This parameter is critical for vibration isolation: a lower wheel-rail resonance frequency produces a better vibration isolation. For comparison, the corresponding resonance frequency of a ballasted track or of a conventional embedded track is about 60 Hz.

After alignment of the track, the concrete slab is poured in one or more phases. The rail trough is filled with the rubber grouting and an elastic joint is put between the rail head and the road surface.

Performance: vibration measurements in exploitation have shown a reduction of 18 dB of the vibration levels generated along the track during tram passages.

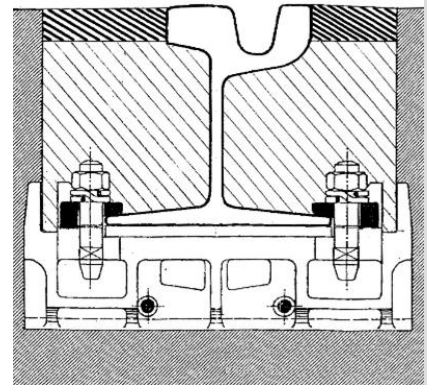
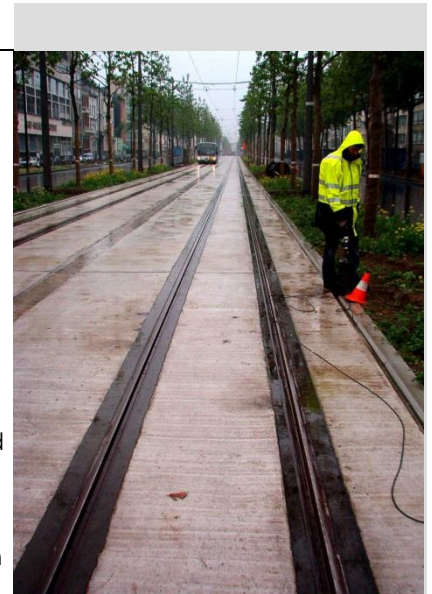

Floating slab track (FST)

D2S International designs and evaluates floating slabs to mitigate ground borne noise and vibrations.

A floating slab track is a track system constituted of a reinforced concrete slab supported by a resilient layer. The ground borne noise and vibration mitigation performance of a floating slab track is determined by its first natural frequency. The vibration mitigation performance of the floating slab is increased by lowering its resonance frequency: increasing the mass of the concrete slab or increasing the resiliency of the elastic layer.

References

- Athens Metro, Stavros extension (Attiko Metro, 2003);
- Tramway of Brussels, chaussée de Charleroi (STIB, 2003);
- Tramway of Bordeaux, France (Alstom, 1999);
- Tramway of Brussels, line 55 (STIB, 1999);
- Athens Metro, New Acropolis Museum (Olympic Metro, 1997);
- Brussels Metro, Erasme extension (STIB, 1997);
- Paris, EOLE, Cogedim zone (SNCF, 1996);
- Brussels Leopold Railway Station (SNCB, 1994);
- Brussels Midi Station, HST (SNCB, 1994).

Design of a floating slab

- conceptual design, based on the specific constraints of the project, a.o.:
 - required mitigation performance;
 - technical specifications of the project;
 - rolling stock characteristics;
 - available height for the floating slab;
 - accessibility of the work locations.
- numerical simulation of:
 - the static and dynamic behaviour of the FST;
 - the vibration mitigation in buildings nearby;
 - if required, the seismic behaviour.
- technical assistance for product and subcontractor selection.
- final detailed design, based on the following elements:
 - civil engineering details (drainage, piping, walkway, ...);
 - electro-mechanical details (stray current, traction);
 - structural elements (geometry, ...).
- acceptance testing of materials.
- follow-up during construction.
- measurements and performance evaluation.

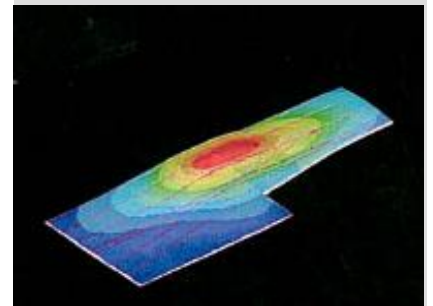
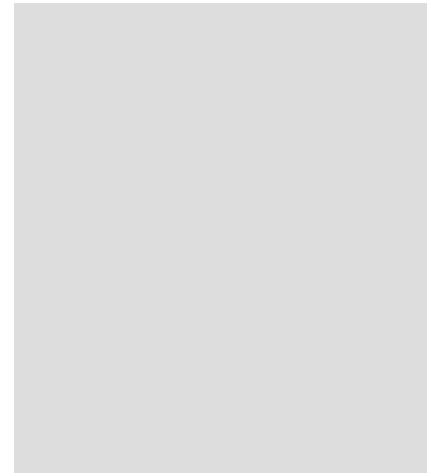

LABORATORY TESTS

D2S International has access to test facilities, which offer a wide range of possible tests aimed at guaranteeing the long-term behaviour of specific track designs.

The tests are performed as part of track acceptance procedures or to determine the suitability and capability of newly designed track and its components.

Laboratory tests are carried out according to the applicable European or International standards. A specific strength of D2S International is the ability to compose test specifications in situations where current normative reference is absent or not conclusive.

The laboratory is equipped with test benches, presses and specific actuators (e.g. hammer impact, electro-dynamic excitator).

A dedicated test bench with a bogie and two axles is available to perform static, dynamic and fatigue tests on complete track sections.

Tests include:

- static and dynamic stiffness tests;
- repeated load tests (fatigue);
- track-bogie tests;
- freeze/thaw cycle tests;
- pull tests.



LIFE CYCLE COST ANALYSIS FOR TRANSPORT INFRASTRUCTURE



History

- Life Cycle Cost Analysis became popular in the 1960's when the US government agencies started using it as an instrument to improve cost effectiveness of building and equipment procurement.
- From that point, the use has spread in the business sector for all kind of project evaluation and management accounting.
- In recent years the use is applied more and more in the Public Transport sector due to the appearance of Built-Operate-Transfer (BOT), or similar contracts.
- The private entrepreneur and the financing organizations need to calculate in detail investment and operation/maintenance costs and the relationship between both.
- In this activity input can be expected from the traditional (government owned) transport system operators (clients) who have gained expertise by operating the system during long periods of time.

General

- The purpose of the Life Cycle Cost Analysis (LCCA) method is to calculate the overall costs of project alternatives and to select the design that ensures the system will provide the lowest overall cost of ownership/operation consistent with its quality and function.
- The LCCA has to be performed early in the design process while there is still a chance to refine the design to ensure a reduction in Life Cycle Cost (LCC).
- The first and most challenging task of a LCCA is to determine the economic effects of systems or the alternatives and to quantify these effects in terms of money.
- The LCCA calculates the costs of a system or a product over its entire lifespan including: planning, design, procurement, installation, operation, maintenance, replacements & disposal or salvage.

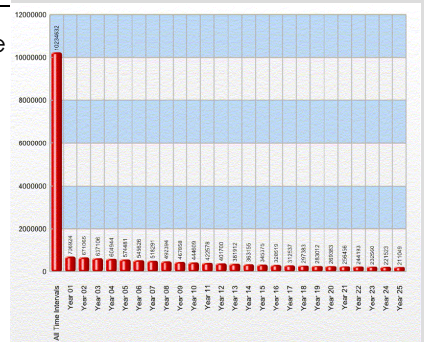

Methodology

D2S International proposes a 2 step approach:

- Step 1: Ranking of alternatives;
- Step 2: Detailed analysis of selected alternative(s).

Important issues and methods included in the proposed LCCA:

- Clients approval;
- Technical and financial risk analysis;
- RAMS (Reliability, Availability, Maintenance, Safety) data integration;
- System availability cost integration;
- Predictive and preventive maintenance effects;
- General sensitivity analysis;
- Sustainable solutions.

Fields of application

The methodology described above can be applied to different public infrastructures including rail transport systems and public road transport systems:

- Track work;
- Power supply system;
- Power distribution system;
- Telecommunication system;
- Automatic fare collection system;
- Stations/stops equipment;
- Operational control centre;
- Depot and maintenance shop.

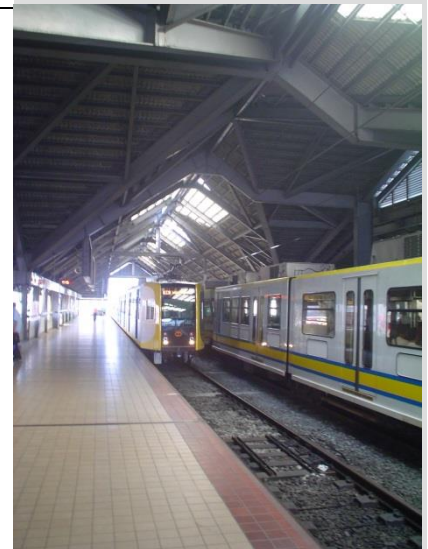
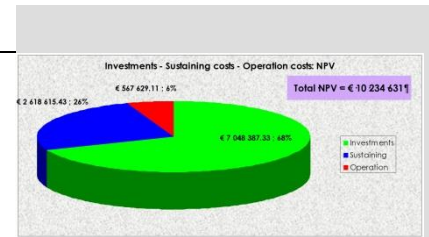

MONITORING

D2S International designs and installs monitoring devices for the continuous measurement of custom selected parameters such as noise, vibrations, stress, temperature, soil pressure and many more.

Monitoring can prevent damage to buildings, structures & sensitive equipment, can demonstrate annoyances to residents living nearby or can assist during legal procedures.

Monitoring data can be transmitted through secured internet connections to our servers in our HQ.

24/7 alerting by text message (SMS) in case pre-set levels are exceeded, is possible.

Monitoring devices are installed during construction works (piling, drilling, digging, demolition) or for permanent monitoring. Examples are vibration monitoring of satellite communication links, server rooms, noise monitoring along airport runways, soil slope stability monitoring, ...



RESEARCH & DEVELOPMENT

D2S International has been partner in several high quality projects within the Research Framework of the European Commission.

URBAN TRACK

Development of an integrated series of modular track infrastructure solutions at low cost, with no or little maintenance, high availability, constant comfort and ensuring great punctuality.



SILENCE

Development of an integrated system of methodologies and technologies for the efficient control of urban traffic noise.



TURNOUTS

Optimisation of special trackwork, especially in urban environment.



CORRUGATION

Development of innovative track solutions to mitigate rail corrugation in urban transports.



MAXBE

Development of validated methodologies/strategies for the monitoring and the diagnostic at an early stage of axle bearings condition, for safety and preventive maintenance.



QUIET-TRACK

Development of very effective track based rolling noise mitigating solutions for trams, regional trains, surface metro and trains in an urban environment with direct application possibility to conventional railway tracks outside the city.



RIVAS

Reduction of railway induced vibrations by addressing the vibration generation at the vehicle level, the track level and in the transmission path.



ACOUTRAIN

Virtual certification of acoustic performance for freight and passenger trains.



PM'n'IDEA

Development of new component designs and maintenance processes aimed at improving the integrity of urban rail transport infrastructure through the deployment of intelligent design and sensor technologies integrated in cost effective products and targeted non-intrusive monitoring processes.



CITYHUSH

Step change solutions to reduce noise in the city environment – Development of suitable problem identification and evaluation tools for the design and development of solutions for hot spots, which show high correlation with annoyance and complaints.



REFERENCES



For a detailed list of references, please go to www.d2sint.com

D2S International

Ambachtenlaan 54
3001 Heverlee
Belgium

www.d2sint.com
d2sint@d2sint.com

T + 32 16 23 89 88